

new move  
Architecture in Motion



Birkhäuser  
Basel

new

Architecture in Motion – New Dynamic Components and Elements

Michael Schumacher Michael-Marcus Vogt Luis A. Cordon Krumme

move

## ■ Contents

- 7 Preface
- 8 The poetics of movement 4.0  
Michael Schumacher
- 12 Movement: Visions  
Christina Chalupsky
- 14 Urban mobility and urban structure  
Max Schwitalla
- A Theory and planning**
- 1 Movement in space and the movement of objects**
- 18 1.1 Perfect skin – the fascination of new materials  
Klaudia Kruse
- 22 1.2 CFRP structures: Uses in aviation – applications in architecture  
Carsten Schmidt
- 26 1.3 Textiles in motion  
Sara Nester, Shankar K. Jha
- 28 1.4 Bio-inspired elasticity  
Jan Knippers, Axel Körner
- 30 1.5 Urban cable cars as dynamic elements in the city and as architecture  
Laura Kienbaum
- A Theory and planning**
- 2 Movement and construction principles**
- 34 2.1 Space on demand: Flexible architecture for changing cities  
Paul Clemens Bart, Marvin Bratke
- 38 2.2 3D printing methods: “Replicate Architecture”  
Mirco Becker
- 40 2.3 Active and transformable: Future movement strategies  
Arndt Goldack, Mike Schlaich
- 42 2.4 Shape memory: Movement through shape memory alloys  
Jonas Kleuderlein, Sara Kukovec
- 44 2.5 Soft robotics: The deformation and movement of soft components  
Annika Raatz, Mats Wiese
- B Applications and functions**
- 1 Changing and extending uses and functions**
- 48 1.1 Flexible furniture  
Olaf Schroeder
- 50 1.2 Adaptive by design  
Kaja Schelker, Werner Sobek
- 54 1.3 A typology of adaptive facades  
Winfried Heusler
- 58 1.4 Retractable roofs  
Knut Stockhusen, Knut Göppert
- 62 1.5 Adaptable houses  
Richard Murphy
- B Applications and functions**
- 2 Conserving and generating energy**
- 68 2.1 Smart skins  
Brian Cody
- 72 2.2 Moving elements for active solar energy use in buildings  
Arno Schlüter, Uta Gelbke
- 76 2.3 Robustness and autoreactivity: Temperature regulation using thermal actuators  
Philipp Lionel Molter, Thomas Auer
- 80 2.6 Energy generation in the city of the future  
Werner Jager, Laura Bugenings, Markus Schaffer
- 84 2.7 Movable and adaptive thin glass applications  
Jürgen Neugebauer, Markus Wallner-Novak
- B Applications and functions**
- 3 Interaction: Recognising, controlling and representing movement**
- 90 3.1 Dynamic design with light: Media facades  
Thomas Schielke
- 94 3.2 4dTEX  
Claudia Lüling, Johanna Beuscher

- 98 3.3 Scissor linkages in the design of adaptive morphologies  
Yenal Akgün, Feray Maden, Şebnem Gür, Gökhan Kiper, Koray Korkmaz, Engin Aktaş, Müjde Yar Uncu
- 102 3.4 Moving bridges  
Cezary M. Bednarski

## **C Buildings and building elements**

### Swivel / turn

- 108 Livraria da Vila  
Isay Weinfeld
- 110 Sharifi-ha House  
Nextoffice + Alireza Taghaboni
- 112 Steirereck Gourmet Restaurant  
PPAG architects
- 114 Cirkelbroen  
Olafur Eliasson
- 116 Scale Lane Bridge  
McDowell + Benedetti Architects  
Alan Baxter Ltd (Structural engineers)
- 118 La Seine Musicale  
Shigeru Ban Architects + Jean de Gastines Architectes

## **C Buildings and building elements**

### Rotate

- 120 Dancing Pavilion  
Estudio Guto Requena

- 122 MPavilion 2017  
Office for Metropolitan Architecture (OMA)
- 124 Kielder Observatory  
Charles Barclay Architects
- 126 Piscine Tournesol  
Urbane Kultur Architectes
- 128 Moving Landscapes  
Matharoo Associates
- 130 Odins Bro  
ISC Consulting Engineers A/S with Bystrup Arkitekter og Designere

## **C Buildings and building elements**

### Slide

- 132 Paperhouse  
Heatherwick Studio
- 134 Renault Symbioz House 33  
Marchi Architectes
- 136 Theatre Tower on the Julier Pass  
Giovanni Netzer, Walter Bieler
- 138 Duke of York Restaurant  
NEX-Architecture
- 140 Inderhavnsbroen  
Studio Bednarski with COWI UK
- 142 Wembley Stadium  
Foster + Partners

## **C Buildings and building elements**

### Flap

- 144 Aktivhaus B10  
Werner Sobek
- 146 MPavilion 2014  
Sean Godsell Architects
- 148 Ballet Mécanique  
Manuel Herz
- 150 Villa Chardonne  
MADE IN Architecture
- 152 Gdańsk Shakespeare Theatre  
Renato Rizzi with Proteco Engineering S.r.l.
- 154 Olympic Tennis Centre  
Dominique Perrault Architecture

## **C Buildings and building elements**

### Fold

- 156 Canary Wharf Kiosk  
Make Architects
- 158 Café-Restaurant OPEN  
Pi de Bruijn and de Architecten Cie.
- 160 Mokyeonri Wood Culture Museum  
Eunju Han + softarchitecturelab
- 162 Parliament Visitor Centre  
GEISWINKLER & GEISWINKLER Architekten ZT GMBH
- 164 Centre for Paediatrics and Cardiology at the University of Innsbruck  
Nickl & Partner Architekten
- 166 Al Bahr Towers  
AHR

## **C Buildings and building elements**

### **Swing**

- 168** Windswept  
Charles Sowers
- 170** Wave Wall  
Charles Sowers, Shawn Lani and  
Peter Richards
- 172** Curtain Door  
Matharoo Associates
- 174** Mobile footbridge in Stalhille  
NEY+ Partners
- 176** Lower Hatea River Crossing  
Knight Architects
- 178** Merchant Square Bridge  
Knight Architects

## **C Buildings and building elements**

### **Deform**

- 180** “La ville molle”  
Atelier Raum
- 182** Kinetic Wall  
Barkow Leibinger
- 184** Bezier Concertina display  
Stacklab
- 186** IBA Soft House  
Kennedy & Violich Architecture and  
Knippers Helbig Advanced Engineering
- 188** MegaFaces  
Asif Khan Ltd. with iArt

- 190** One Ocean  
soma architecture  
Knippers Helbig Advanced Engineering

## **C Buildings and building elements**

### **Complex movements**

- 192** XXXX Sofa  
Yuya Ushida
- 194** EvolutionDoor  
Klemens Torggler
- 196** Fissured Living  
Matharoo Associates
- 198** Scissor bridge at Jet d’Eau  
Ingeni Ingenieure + MID Architecture
- 200** The Bund Finance Centre  
Heatherwick Studio and Foster + Partners
- 202** Institut du Monde Arabe  
Jean Nouvel, Gilbert Lézénès, Pierre Soria,  
Architecture Studio

- 206** About the authors and contributors
- 214** Acknowledgements
- 216** Illustration credits
- 219** Sponsoring companies
- 223** Colophon

## ■ Preface

Ten years after the publication of the first *Move* book, it is once again time to ask:

What moves us? How is architecture moving? And, what is moving in architecture?

The aesthetic richness of how objects move in space is a fundamental and formative perceptive experience. The grace of an elegant movement rarely fails to capture our attention.

This is especially true when it causes a building to radically change its appearance. Whether it happens suddenly as a rapid transformation from one state to another, or gradually and continually as a building adapts to changing conditions, the transformation is a captivating experience. Even more powerful is the movement of multiple elements in parallel, or an unfolding choreography of moving parts.

The composition plays as much a part in this as the play of forces. The challenge lies in the interplay of the different factors, and in reducing them to their essence – in creating simple systems that can produce complex movements to fulfil specific functions.

At the Institute of Design and Construction, Leibniz University Hannover we examine design and construction through the lens of the many interactions and interdependencies to which a building element responds. Particularly instructive in this respect is the study of moving elements. Conceiving and developing functioning sequences of movements, and testing them in built models, presents an excellent opportunity to learn about the interplay of materials and their connection, and about putting an idea into practice.

The design of a construction detail determines how forces come together and are distributed, how different materials meet one another, how tolerances are accommodated, and functions are linked up and networked. As a design problem, it teaches us how to resolve the often multidisciplinary requirements that come together in a single small element or joint. The aspect of movement makes the problem considerably more complex.

In a series of seminars, and by closely following developments in architecture and technology, we have continued to explore and conduct research into the aspect of movement in architecture. *New Move* documents the current state of research and practice. In the years of research leading up to *New Move*, a range of key aspects have emerged that seem to us to be relevant for the design of movable building elements and suitable for the strategies of tomorrow. Promising approaches include simplifying construction, the transfer of innovations from other sectors and the modular linking of small systems into larger components.

*New Move* discusses these possibilities and opens inspirational perspectives for further visionary concepts. We would like to thank the authors who contributed to this book and our team for their exceptional commitment in producing the contents and graphics for the book. Likewise, we thank our sponsors, without whom this book project would not have been possible. We wish you, our reader, much in the way of fresh inspiration and great pleasure in discovering new design concepts and practical solutions for working with moving building elements.

Michael Schumacher, Michael-Marcus Vogt, Luis A. Cordón Krumme  
August 2019

BB-8 Droid – *Star Wars*

## ■ The poetics of movement 4.0

Michael Schumacher

In January 2007, Steve Jobs first introduced the iPhone at the MacWorld Conference & Expo in San Francisco. By the end of the year, more than a million iPhones had been sold around the world.

In the introduction to our previous book *Move*, published in 2010, I discussed the essential role of movement, of elegant, sensory movements using the example of the then still unfamiliar handling of the user interface of a smartphone. The idea of “pulling open” a “window” with one’s fingers was completely new, even 15 years after IBM’s first mobile phone touch screen, as was the fact that the same point on a screen can serve all manner of functions when touched.

At the time, I wanted to show how universal and how intrinsic our sense of balance, weight and statics is to every movement we encounter, even when virtual and not strictly necessary in an electronic environment.

How the world has changed since then! “Pinch to zoom” has become so all-pervasive that adults and young children alike are disappointed when a surface – be it an “old” television or even the bathroom mirror – fails to respond as expected. Alongside the many practical uses that new gesture controls will undoubtedly bring, we can also expect them to provide us with many a comical moment. Think of all the frantic waving necessary to open or close a sunroof: it’s too bad that the likes of Tati are no longer with us to mischievously portray the absurdities of life in our technological age.

But one thing is certain: the importance of movement in a general sense has risen. Millions of people

now cycle, jog and run in droves through today’s cities. In this book, however, it is not movement in terms of countable units and personal records that interests us but rather the poetics and the beauty of movement that enriches our lives beyond what is materially necessary.

### **Movement and emotion**

A recent creation from the world of cinema that particularly impressed me in the context of movement is the small spheroid BB-8 that debuted in *Star Wars: The Force Awakens* as a replacement for R2-D2. The rolling sphere, drawn by J. J. Abrams, who gave it its name, along with Lawrence Kasdan and Michael Arndt and probably a small army of other animators, masterfully encapsulates the magical quality of designing movement.

What could be less practical and least easy to control in its movements than a sphere on which a rolling head is precariously balanced? As anyone who has purchased a remote-controlled version of the cheeky droid will know, controlling the ball from the iPhone app is easier said than done as it skids across the floorboards or loses its head before zig-zagging crazily across the floor to disappear behind the radiator! But aside from the not unimportant control characteristics in real (robot) life, BB-8 is a master of expression far eclipsing that of R2-D2. The “free-moving dome head” manages so convincingly to convey emotions ranging from lost in thought, doubt and scepticism to decisiveness and empathy that one cannot fail to find it adorable, despite its hard shell. For me, BB-8 is a fantastic

example of how quite complex mechanical movements can express feelings very directly.

While this book deals with perhaps less spectacular and less big-budget examples, significant progress has also been made at the more practical level of movement in architecture.

### **Movement and function**

My partners at my office gave me a wonderful birthday present: an electrically powered and electronically stabilised unicycle. It has quickly become my new mode of urban transport: it’s easy to use, sufficiently speedy and requires little space. It fits perfectly in the context of this book, fulfilling its purpose not just practically and functionally but also with a measure of poetry, fascination and delight. There is, however, one drawback: at present no regulations exist as to how such vehicles should be used in public areas. As such, its use in public is not permitted, as I discovered one day when I was stopped outside Frankfurt Railway Station by four perhaps somewhat overzealous policemen while on my way home. To be fair to the German judiciary system, the legal case was eventually dropped, and I now use the wonderful unicycle to travel from one end of our basement archives to the other.

What the story shows, however, is that we are at a turning point in our approach to mobility. The importance accorded to cars (in particular as a status symbol) is waning, especially among young people. A wide range of electrically powered vehicles, ranging from unicycles to skateboards and roller scoot-



New urban mobility: an electrically powered, electronically stabilised unicycle

ers or e-bikes, is expanding and diversifying the ways in which we can feasibly travel different distances.

New technologies are making it possible to turn concepts into reality on a large scale. Alongside these and the movements that new modes of transport bring, with their consequences for architecture and urban planning, this book also deals with movements and their poetic qualities that we encounter in our daily lives on a small scale.

“ParQ” is a height-adjustable desk of the kind increasingly seen in offices with enlightened managers. The problem of designing a height-adjustable desk is not easy to resolve in an aesthetic manner. The Dutch manufacturer Vepa has approached this by arranging two tabletops back to back with a central acoustic dividing panel between the two. The divider creates a sense of order and unity in what

would otherwise be a chaotic array of different height desks. But its standout feature lies in the construction of the elevating tabletops and their diagonal supports. A clever mechanism ensures that the desktops do not veer away from the rear divider when being raised, as one would expect, or jam against it when descending, but instead move up and down parallel to the divider. The effect is clean and intriguing. Not everyone will stand in wonder at how it has been achieved, and many may not even notice, but it is precisely such “effects” that constitute its attraction and beauty and make it an enjoyable and satisfying piece of furniture.

thyssenkrupp have developed a new kind of elevator called the “Multi”. Using linear motor technology instead of cables, it utilises electrically controlled magnets to move the elevator cars up and down, or indeed horizontally. Like a paternoster lift, the cars

move in a circuit, making it possible to operate several cars within a single shaft to reduce waiting times while transporting more people. As ever more people live in cities and conurbations, and buildings become ever higher and cities ever more dense in an effort not to sprawl endlessly into the green surroundings of the hinterland, such developments can play an important role in urban planning in the coming decades. The lifts require less space in the floor plan of tall buildings and the weight of the cables, which is a crucial factor in the design of very tall high-rise buildings, is not an issue. Similarly, such developments make it possible to create high-rise buildings connected by bridges.

The key to many such ingenious solutions often lies in the details. Sliding doors are no longer as revolutionary as they once were, but they remain a very practical solution as they make it possible to use

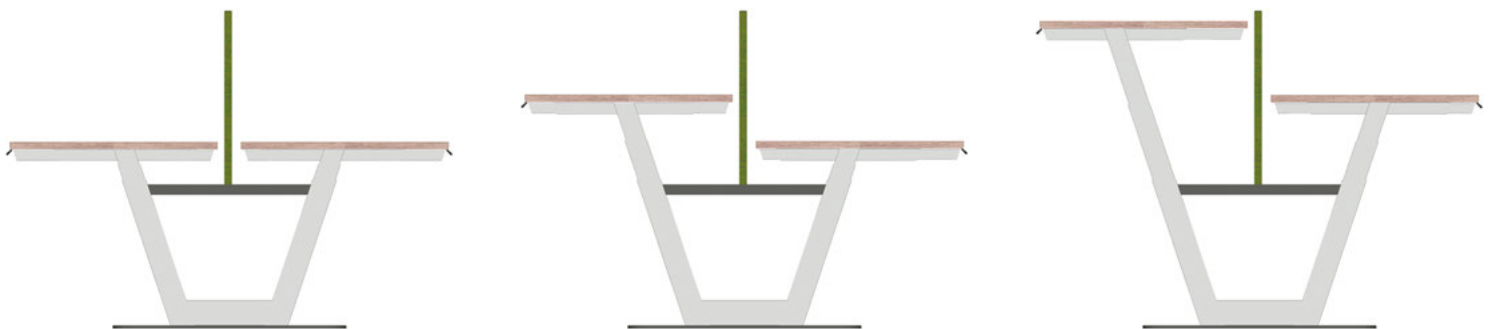

ParQ – a height-adjustable desk



Facade study for Qianhai Information Building, data centre, Shenzhen, China, schneider+schumacher

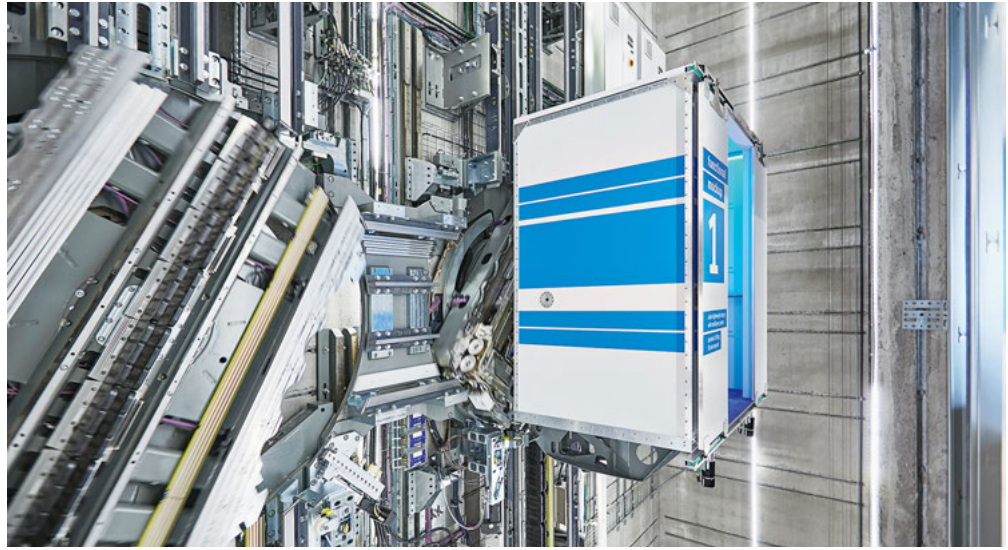

Rethinking mobility inside buildings: "Multi" – a ropeless elevator by thyssenkrupp

the dead space that usually has to be left free for the door swing. Until recently, however, they did not provide good sound insulation. The solution, it turns out, is so simple that one wonders why it was not always the case: all that is needed is a minor correction to the passage of the door leaf in which the direction of travel is shifted at the moment of closure.

#### **Movement and material**

An important new field of study in this book is the topic of materials. New material innovations, especially with regard to properties such as elasticity, strength and electrical conductivity, are opening up fascinating new possibilities for construction. Carbonfibre reinforced plastic (CFRP) structures are increasingly being used for a variety of purposes in aviation and shipbuilding. New research is exploring the potential of materials that can change their geometric form as a factor of their material properties rather than with the help of hinges, guide rails or external drive systems. For example, wing profiles for aircraft that "adapt independently" to flight speed, increasing lift at just the right moment. In the field of architecture, this could be used for vent coverings or shading elements and adaptive solar facades that adjust their position "on their own" in response to the angle of incident light. While many

of these developments are currently in the prototypical phase, such constructions are already being trialled in practice.

Even in such fields as bridge building, where structures are built to last 100 years or more, new partially adaptive materials are increasingly beginning to play a role.

But it is not just materials that offer new possibilities for the design of moving building elements. Manufacturing methods such as 3D printing make it possible to produce functioning hinges without having to join together separate parts. Drive chains, hinges and even entire transmission units can be made in a single manufacturing step.

Nevertheless, architecture as a whole is unlikely to play a leading role in pioneering innovations in material developments because the long-term durability of new materials is not yet known and because buildings, unlike vehicles and aircraft, are not serviced with the same degree of regularity.

But the ambition of architects and engineers (the Masters of Arts and Masters of Sciences) schooled in aesthetics, innovation and interdisciplinary collaboration along with the imperative to work towards a more truly sustainable use of the planet's resources will bring forth new aesthetic, functional and wonderful possibilities to experience and enjoy our built environment.

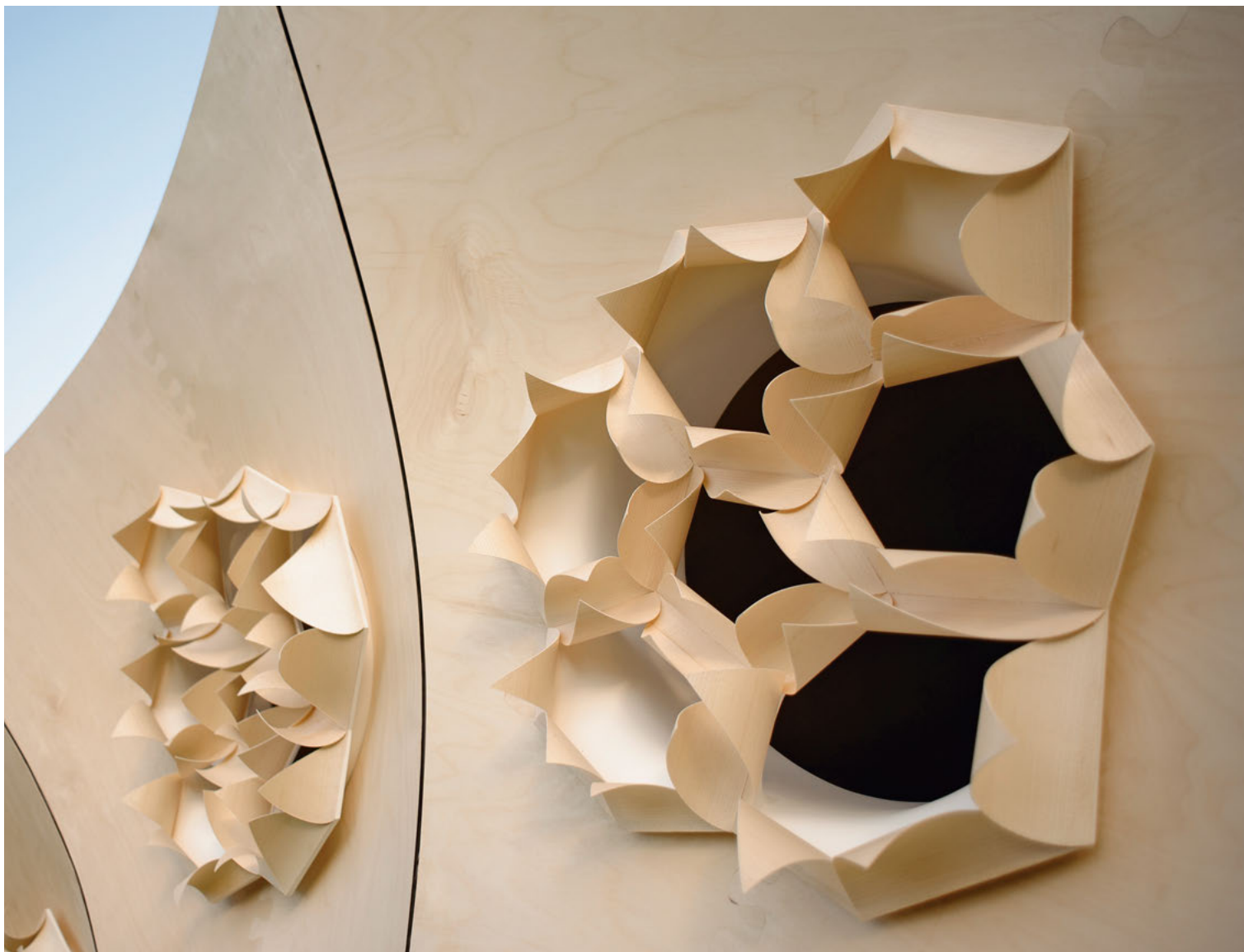

HygroSkin: responsive wood lamella in the HygroSkin Meteorosensitive Pavilion, ICD University of Stuttgart – Achim Menges in collaboration with Oliver David Krieg and Steffen Reichert

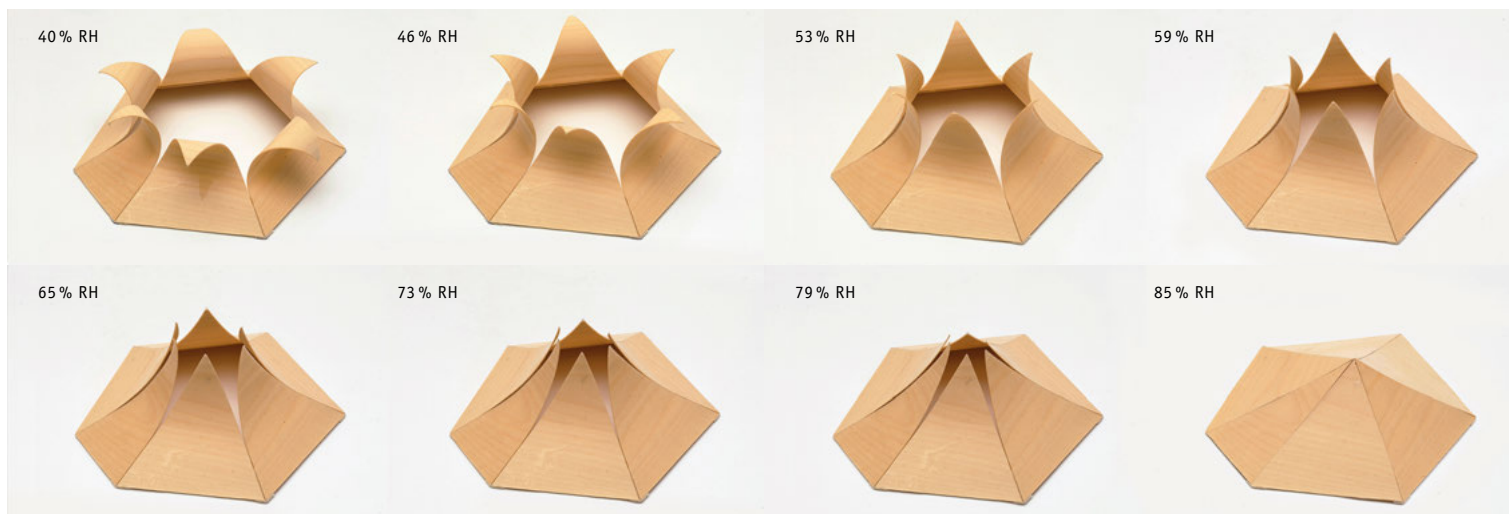

Detail of HygroSkin: the aperture size changes in response to the level of relative humidity; materials research and facade study, ICD University of Stuttgart – Achim Menges in collaboration with Oliver David Krieg and Steffen Reichert

## ■ Movement: Visions

Christina Chalupsky

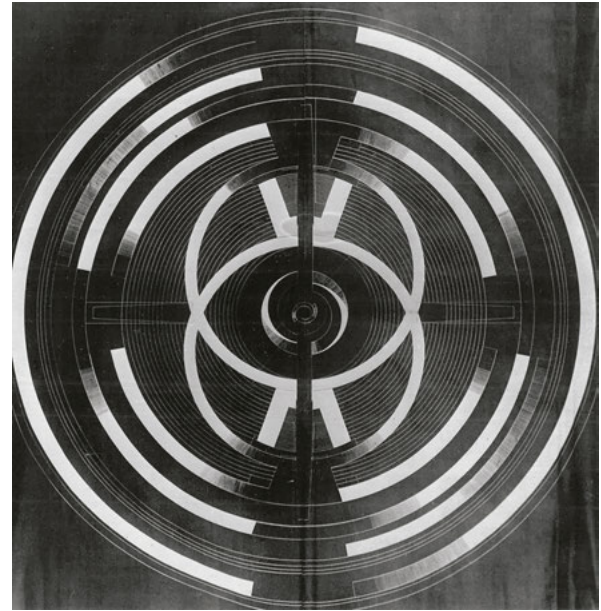

Endless Theatre, Frederick Kiesler, 1925, floor plan<sup>1</sup>

Driven by the desire for a better world, visions and utopian ideas have always been an elementary part of architecture. Progress is associated with movement, with movement directed towards something new worth striving for. As such, visionary projects about movement at the interface of architecture and art are directed towards shaping the future.

### Visionary space theatre

Frederick Kiesler, the Austrian-American architect, artist and theatre visionary, spent his entire life examining questions of flexibility and multifunctionality. In numerous projects, he explored and elaborated his ideas on permanent spatial continuity and endlessness. In 1924 at the “International

Exhibition of New Theatre Techniques” in Vienna, he presented the Space Stage, which was erected in the Vienna Konzerthaus. It took the form of an open construction with several stage platforms connected by a spiral ramp, a system of stepladders and an electric elevator. The constructivist tower made it possible to present several scenes simultaneously and at different heights. There was no scenery at all, and the stage space was open on all sides. His intention was to enable the audience to experience the action on stage at different levels and literally to “unseat” them from their passive role in traditional theatre. The performance, the experience and one’s own self-reflection should be inseparably intertwined.

Kiesler’s original vision was to place the audience on rotating platforms that floated around the space stage. In the actual built instance in the orchestra hall of the Konzerthaus, the audience sat high up on the balcony that surrounded the space stage in a U-shape.

Despite meeting with considerable criticism initially, Kiesler’s experimental space stage proved inspirational for other theatre visionaries, including the American Julian Beck with his Living Theatre. A few years later, Kiesler returned to the idea of the temporary stage and transported it, without intending to build it, into a spherical theatre form, which he called Endless Theatre. The floor plan showed the stage as a composition of concentric circles, but the

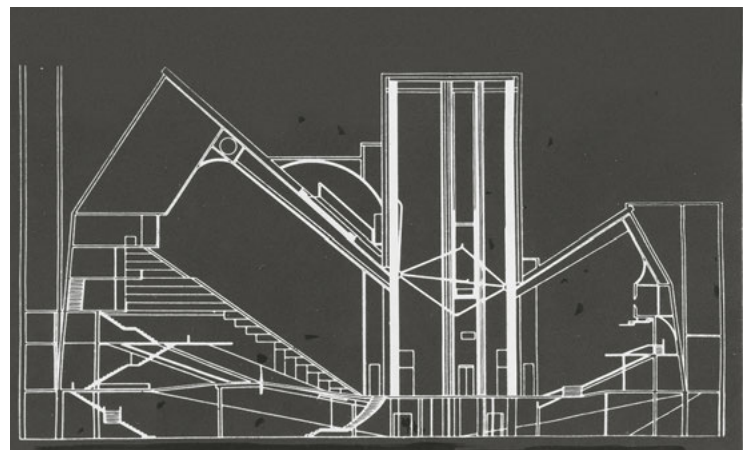
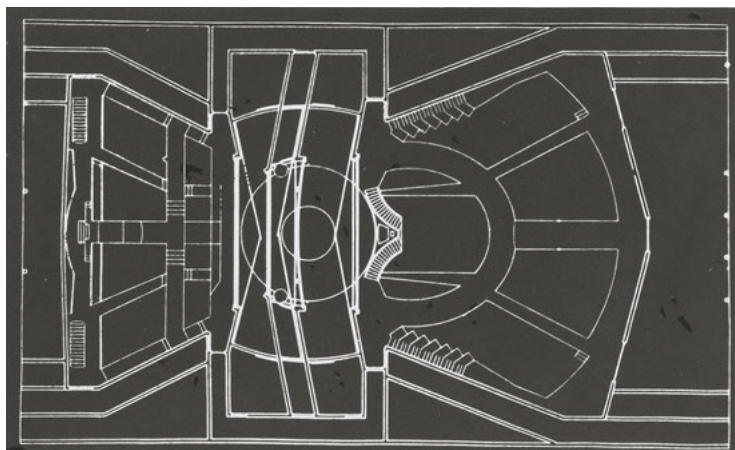

Plan and section of theatre project for Brooklyn Heights, Frederick Kiesler, 1926. Double theatre with common stage for separate or joint use (small and large house).<sup>1</sup>



Night view of the sculpture "Galaxy", Dvizhenie, 1967

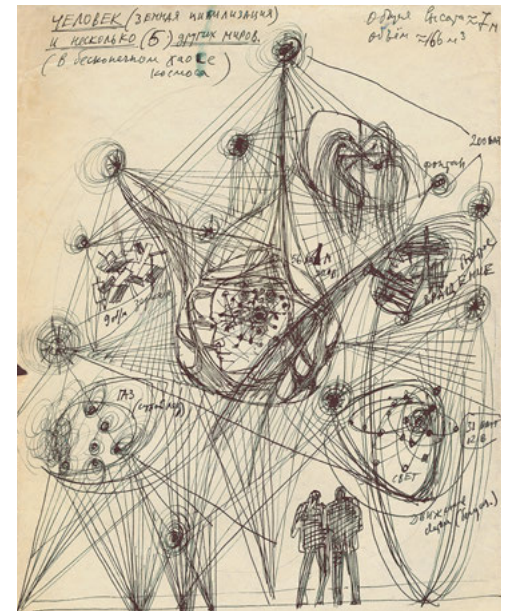

Design sketch of "Galactica", Lev Nussberg, 1967

section revealed the design as being elliptical, interspersed with thin looping paths.

Kiesler's interest in the idea of endlessly flowing space may have derived from his great interest in physiology and psychology. He was convinced that flexible spaces were good for the development of the human psyche, describing the interaction between humans and building in terms of input and output. From this idea of continuous reciprocal interaction, he would later develop the design theory of Correalism.

The example of Kiesler clearly shows the potential of the laboratory character of theatre. In the 1920s, the theatre served many other artists as a realm in which to explore utopian spatial concepts as a model for a new aesthetic and social order.

### Utopian fantasies

The artistic creations of Lev Nussberg also revolve around the relationship between elements and their transformation into a new state. The Russian artist, architect and designer is known for his kinetic spectacles. He founded the artist group "Dvizhenie" ("Movement") and became a leading proponent of kinetic art, an abstract art form that evolves in space and time.

Nussberg worked tirelessly not only to identify but also to portray the problems of humankind and society. The idea was always of prime importance, not least because the material and financial means necessary to realise it were often lacking. Nonetheless, Nussberg and his colleagues in the "Dvizhenie" group succeeded in putting on a remarkable number

of quite elaborate art installations and performances while in Russia, although not always with official permission. He elevated symmetry to one of the most important conditions of his art.

In October 1967, the group succeeded in realising "Galaxy", a crystalline sculpture about 3 m high made of metal struts and synthetic cord that was exhibited as part of the "Scientific and Technical Creativity of Youth" exhibition in Moscow. It was a prototype intended as a sculpture for the central urban space of the newly planned towns being built throughout the Soviet Union. Driven by electric motors, the kinetic installation featured angular forms that moved to the rhythm of the music and was to be illuminated with coloured lights at night.

### Radical machine architecture

The British architect and visionary Cedric Price also explored the active role of the spectator and attempted to redefine it. His widely acclaimed concept for a Fun Palace, a cybernetic cultural venue for events, aimed to make theatre, concerts and educational events accessible to a broader audience, in turn stimulating cultural production and a sense of community.

Supported by theatre director Joan Littlewood and promoted by British intellectuals, his ambitious project aimed to place the audience at the heart of the production, turning it into an active rather than a passive cultural experience. The interests of the visitors would determine the programme and content on show. As such, the architecture of the Fun Palace did not have a predefined programme of

spaces but rather an open spatial structure comprised of movable elements. Various spatial elements, such as lecture halls, stages, footbridges and ramps, were suspended from the ceiling of an open steel structure, and mechanically and electrically shifted almost imperceptibly to form new spatial configurations based on feedback from sensors that monitored the activities of the visitors. The innumerable possible combinations meant that visitors would have the greatest possible freedom of movement.

Although never realised, Cedric Price's Fun Palace served as inspiration, for example, for the Centre Pompidou in Paris, designed by Renzo Piano, Richard Rogers and Gianfranco Franchini.

The idealistic thinking of all these protagonists and their visionary projects for theatre, art and urban space are ultimately motivated by a desire to further the process of social renewal. In their work, moving components play an important role as a means of enabling new possibilities of using and interacting in space.



Future urban mobility as inspiration for sustainable urban planning

## ■ Urban mobility and urban structure

Max Schwitalla

### Stuck urban typologies

The movement of people and the transport of goods have always been arranged in diverse structures and spatial organisations. Cities emerged at crossroads, around marketplaces or along trade routes. Urban forms of living and working have always required adequate mobility solutions, horizontal as well as vertical. For Ludwig Hilberseimer, the novel mobility technologies of the early 20th century were a source of inspiration. His visionary proposal for a high-rise city from 1924 was functionally structured into layers from bottom to top: regional and metropolitan railways, then cars and above, pedestrians.<sup>1</sup> The rapid growth of the world's population, which has doubled to 7.5 billion in the last 50 years alone, has resulted in dramatic global urbanisation. While technological advances have improved quality of life, the spatial logic of urbanisation still follows patterns set down more than 100 years ago based on cars and elevators.

The urban typologies of the 20th century have reached the limits of sustainability: the urban sprawl enabled by car travel has resulted in extensive land consumption and commuter traffic, in turn creating pollution and economic damage through time wasted in traffic jams. Similarly, the vertical cities made possible by elevators have reached the limits of social sustainability. The imbalance between increasing private space for living and working, stacked in towers, and the, in relative terms, decreasing amount of public urban space reduces opportunities for social interaction between people. The ongoing commercialisation of urban space leads to further social segregation. A manifestation of this is the new phenomenon of Dark Towers in New York City, London and elsewhere – exclusive high-rise buildings that are dark in the evening because no-one resides in them except for the money of property speculators.<sup>2</sup> Today's urban typologies can no longer adequately satisfy the human need for

spatial quality and are unable to sustain the acceleration of urban growth that is expected in the coming years.<sup>3</sup> The mobility expert Stephan Rammler therefore argues that the time has come for a systemic reform of our patterns of mobility, urban development and transport infrastructure, in which products and innovations of behaviour are strategically linked.<sup>4</sup>

### Rethinking urban structures: Networks of neighbourhoods

Disruptive innovations, and digitalisation in particular, are bringing about a revolution in urban mobility that will lead to the renegotiation of urban spaces for mobility and property. Property developers are already recognising that it is cheaper to guarantee their residents mobility through fleet management than to construct underground parking for private cars. As we will soon share autonomous vehicles that do not need to be parked at home,



Outdated urban typologies: automotive and elevator cities (for example L.A. and NYC)



The organism of the city as a network of neighbourhoods

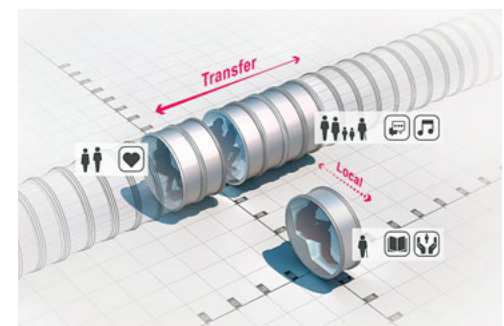

The Flywheel mobility concept



Walkable neighbourhoods as an example of urban planning on a human scale

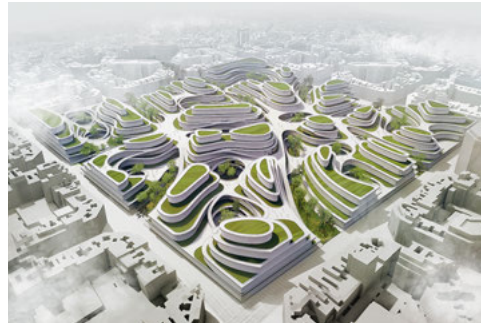

New neighbourhood typologies through electro-micro-mobility



The "Urban shelf": neighbourhoods with spatial qualities

valuable inner-city parking space can be freed up for conversion to other uses. Likewise, new forms of transport, or improved existing technologies such as silent but powerful e-bikes, allow us to think in completely new spatial patterns. How can we envision the cities of the 21st century as innovative typologies that go beyond the horizontal street grid and vertical dead-ends of lifts?

The former deputy mayor of Barcelona, Antoni Vives, defines the city in terms of its practical experience as an ensemble of "hyperconnected neighbourhoods".<sup>5</sup> He understands the urban environment as an organism of neighbourhoods interconnected by public transport networks – buses, metro systems, cable cars and, in the future, point-to-point connections with drone buses. In combination with the last mile distribution of people and goods via mobility and logistics hubs, this intermodal mobility chain provides different scales of transport, from rapid transfer to slower local connections, and responds better to human needs and patterns of urban mobility.

#### **Flywheel: A mobility concept for future networks**

The Flywheel could serve both scales: inter-neighbourhood and last mile transportation within the neighbourhood. The base unit is a space-saving single-seater that can be coupled together into a modular train for energy and space-efficient inter-neighbourhood traffic and decoupled again for the last mile of the journey.<sup>6</sup> This mobility concept, along with an exploration of novel neighbourhood typologies, is the outcome of an interdisciplinary research cooperation between the author and the mobility company Schindler Aufzüge AG.

#### **The neighbourhood: Human scale**

Sustainable neighbourhood planning with a small-scale mix of functions reduces the need for mobility and promotes a sense of identification with the local neighbourhood. The smallest "decelerated mo-

bility unit" is our footwear. As such, walkable neighbourhoods provide an alternative to the car-based, linear and monotonous streetscapes. Different small block sizes with varying and diverse open spaces in between that range from narrow private areas to wide public spaces create a natural spatial transition which helps people orientate within the neighbourhood.

#### **New mobility technologies: Novel neighbourhood typologies**

Social media and communication technologies are changing the way we explore and navigate in urban space. Retail spaces do not necessarily have to be planned at street level; nowadays shops can draw customers' attention to their location via virtual shop windows. The traditional functional division between commercial zones at ground level and residential or work premises above is no longer necessary, and neighbourhoods can be reconceived as three-dimensional networks.

The electrification of micromobility allows the physical manifestation of such networks as circulation within the neighbourhood. E-bikes, for example, make it possible to travel faster, but more interesting is that they enable people to comfortably overcome height differences up until old age. A neighbourhood can be designed as a hilly landscape of stacked platforms: like a mountain range eroded by the flow of people, with ascending and descending cycle paths and terraced public spaces.

A series of double-height platforms accessible via ramps serve as the "Urban shelf", a loadbearing megastructure providing floor, ceiling and technical infrastructure. The open structure can accommodate changes between the platforms, making it adaptable and in turn sustainable while also enabling user participation or even self-building. Two-storey maisonettes or townhouses on the platforms with a front garden for parking small vehicles (e.g. e-bikes) would provide sufficient privacy for residents within the public megastructure.

Ideas for megastructures or flexible infills have existed since the 1950s and 1960s, for example Constant Anton Nieuwenhuys' (1920–2005) utopian project "New Babylon",<sup>7</sup> or Yona Friedman's (1923–) concept for the "Ville Spatiale".<sup>8</sup> But it is only now, in the context of such dramatic urbanisation, that the need to design high-quality, space-efficient, adaptable and sustainable urban space has become so urgent. New technologies are now available to turn such utopian concepts into reality and to help find answers to the pressing challenges of future urban development. Alongside modular and digital construction methods, new materials or innovative fire protection concepts, it will be mobility technologies that allow us to find new ways and to break new ground: we must once again build cities for citizens, with the focus on spatial qualities for people and not on cars and elevators!

1 Hilberseimer, Ludwig: *Groszstadtarchitektur*, Stuttgart, 1927, p. 17. English edition: *Metropolis Architecture*, New York, 2012.

2 Sassen, Saskia: "Global Capital and Urban Land", Urban Age Conference "Shaping Cities", 14-15 July 2016, Venice.

3 Rammler, Stephan; Schöller-Schwedes, Oliver: *Mobile Cities. Dynamiken weltweiter Stadt- und Verkehrsentwicklung*. 2nd extended and revised edition, Berlin, 2012, p. 242. English summary: "Mobile Cities: Reinventing Urban Mobility", *The Global Studies Journal*, 1 (4), pp. 159–168.

4 Rammler, Stephan: *Die Neuerfindung der Mobilität. Mobilität als Weltdesign*, Braunschweig, 2010.

5 Vives, Antoni: "Smart Sustainability for European Cities", Conference "Decarbonising Transport: Smart Mobility Innovation for Sustainable Cities", 15 November 2016, Berlin.

6 Maak, Niklas: "Das beschleunigte Leben", *Frankfurter Allgemeine Quarterly*, 6, 2018. Audi Urban Future Award 2014 – Team Berlin, <https://vimeo.com/111542258>, accessed on 09/08/2018.

7 van Schaik, Martin; Máčel, Otakar: *Exit Utopia: Architectural Provocations, 1956–1976*, Munich, 2005.

8 Friedman, Yona: "Vers un urbanisme tridimensionnel", *Architecture d'Aujourd'hui*, 33 (102), 1962, pp. 76–77.

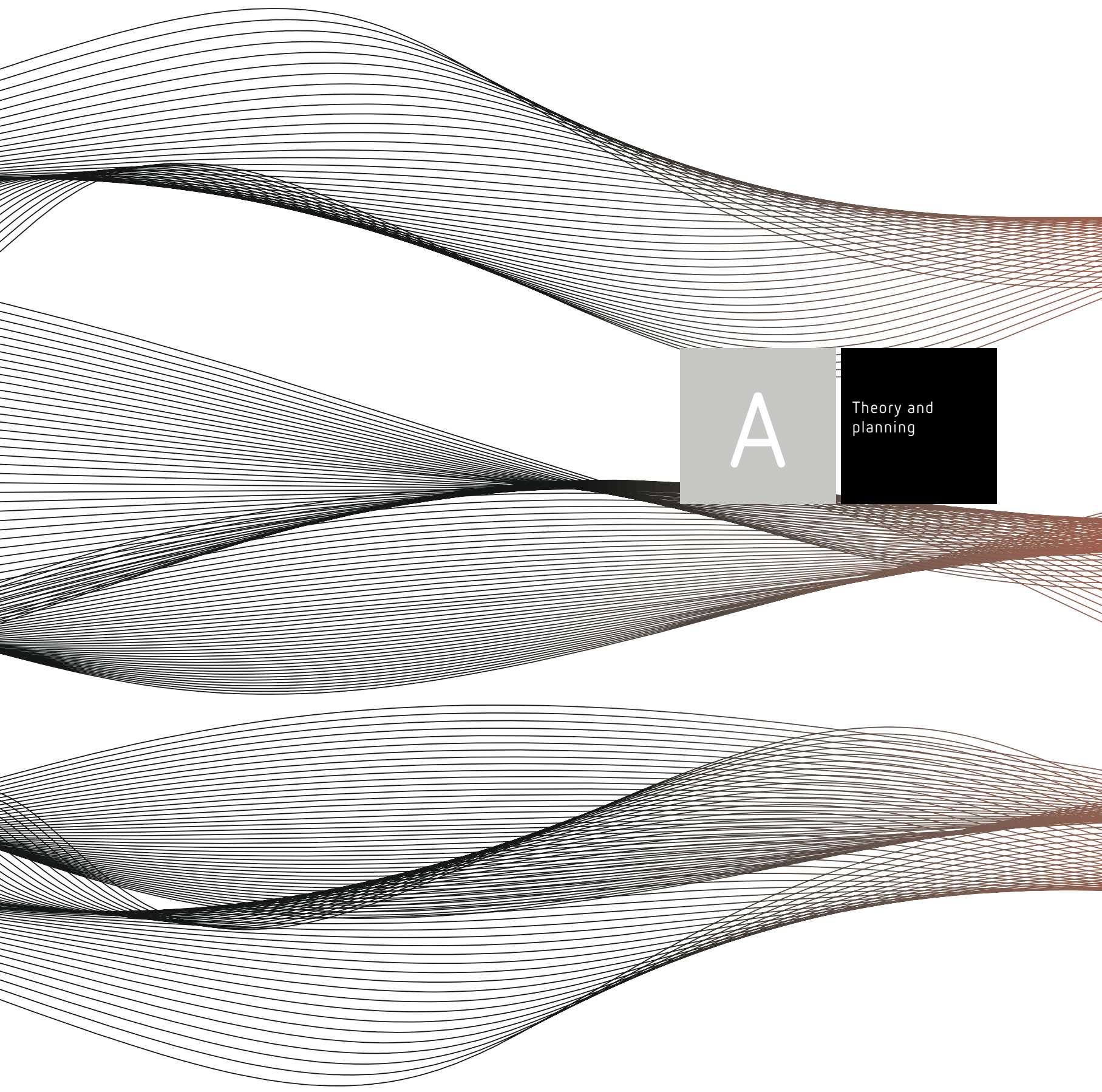

A

Theory and  
planning

The background of the page is composed of numerous thin, red, wavy lines that create a sense of motion and depth. These lines are arranged in a way that they appear to flow and curve across the page, creating a complex, layered effect. The lines are most dense in the center and become sparser towards the edges, giving the impression of a three-dimensional space. The overall color palette is a vibrant red against a white background.

1

Movement in  
space and the  
movement of  
objects



SkySong Phoenix – a floating dynamic sculpture

## ■ 1.1 Perfect skin – the fascination of new materials

Klaudia Kruse

Movement and dynamics, i.e. the ability to change appearance or materiality, is something that enralls and captivates our perception. The capacity to surprise, to change form and character, to assume new identities, to take on a new purpose or be usable in a new context can take many different forms.

Innovations in manufacturing such as 3D printing, breakthroughs in materials research such as the discovery of graphene 15 years ago as a lightweight, high-strength material, as well as new developments in technology and science such as artificial intelligence, are opening up unprecedented degrees of freedom to designers.

The desire for beauty in simplicity, for pure, smooth surfaces, concealing beneath them unknown mysteries, reflects an appreciation of an innate quality that we value and is more than merely a trend. Re-

search and development have long focused on sustainability, recycling, upcycling, re-creation and re-use. The combination of these – beauty and poetry along with sustainability and functionality (“bio-tiful”) – produces items of tangible value.

Interdisciplinary aspects such as the fusion of materials, manufacturing processes and information are a reflection of a desire for connectivity and for intuitive operation and use. The accessibility and functionality of smart technology and artificial intelligence in our immediate environment – in architecture and interiors, in cars, fashion or product design – are becoming easier for people to engage with and to adapt to their own needs. User-friendly interactive systems make life easier, although they should still be used mindfully.

Sources of inspiration for design and new applications derive from the most diverse areas of research

and development. On an interdisciplinary level in particular, they use as well as generate synergies. The context in which a new product or technology evolves or a user lives, and the story behind it, help us engage with it. Our fascination with the unknown and with exciting contrasts – whether distinct or gradual, moving or static, perfect or imperfect, between colours, surfaces or information – together create the momentum that triggers our perception, captivates our attention and becomes an experience.



BMW Gina – a sensual fabric skin



BMW Gina – automotive haute couture



BMW Vision Next 100 – flowing geometry



Wynyard Walk, Sydney – infotainment on the move

### ARCHITECTURE + FASHION + MOBILITY

*GINA BMW concept study, 2008*

Transformation – The skin as a perfect expression of movement

The GINA Light Visionary Model with its flexible textile cover has an almost seamless outer skin stretched over a movable substructure. The flexible covering makes it possible to adapt its form to different speeds of travel. The interior can respond flexibly to make more space available for storage or reveal certain functions only when needed.

“Design minimalism” and new, unusual materials play a central role in the architecture of this car, which draws inspiration from fashion and clothing design.

A highly elastic material originally developed for swimwear – discovered by the author at *Première Vision* in Paris – and its transfer to the realm of automobile design was the revolutionary impulse and starting point for a new creative process and a new design language at BMW.

It opened up unexpected degrees of freedom in functionality and design, as well as for groundbreaking production and sales strategies.

### ARCHITECTURE + DYNAMICS

The flexible quality and transparency of surfaces and the new design language also inspired the BMW Design Team to conduct the *BMW Vision Next 100 concept study, 2016*.

The concept car is an expression of dynamics, variability and individuality – tailor-made with intelligent materials and new manufacturing processes to create an emotional, intuitive experience of changeable geometries. Drawing inspiration from the architecture of the tensile roof structure of the Munich Olympic Stadium by Frei Otto, the interaction of the automobile surfaces creates dynamic, revolutionary sculptures.

### FLOATING CONNECTOR

*ASU SkySong infrastructure, Arizona State University, Phoenix*

FTL Design Engineering Studio NYC, Nic Goldsmith, 2010

Spanning a road crossing and four squares, the iconic structure designed by FTL provides cover and shade from the sun. Situated at the heart of a new centre with shops and restaurants, the passively cooled tensile structure also collects rainwater. FTL’s tensegrity beams allows the design of the textile canopy to reach out to and connect the surrounding buildings without actually touching them, resulting in a floating dynamic architecture.

### MOBILE ARCHITECTURE

*Volvo Cars Safety Centre crash test, Gothenburg, 2000*

This building employs dynamically adaptable architecture to answer a technical need: a section of the building is mounted on air cushions and can be rotated around a 90° arc to place it at an angle to the rest of the building. This makes it possible to test different angles of impact when undertaking crash tests. Taking this idea further, entire buildings could be moved from their respective stationary location on air cushions, making the immobile mobile.

### ON THE MOVE – INFOTAINMENT

*Wynyard Walk Studio, Sydney*

Woods Bagot Architects for Transport New South Wales, 2016

Wynyard Walk is a 9 m wide, 180 m long pedestrian tunnel that connects Wynyard Station with Barangaroo on Sydney Harbour. The multi-award winning pedestrian walkway uses six large, integral screens with digital imagery to turn the flow of pedestrians into a special experience. The design concept is based on the idea of flow as a metaphor for the continuous stream of pedestrians, drawing inspiration from the nature and geology of the region with its landscape of deep cliffs, gorges, beaches and estuaries. As creative as it is functional, this space combines art, culture and technology into a series of visual experiences.



GRDXKN – applied three-dimensional printed textures

### NEW MATERIAL EFFECTS

#### GRDXKN

Bastian Müller, industrial designer, 2017

This new textile printing technology makes it possible to print two-dimensional colour applications as a three-dimensional texture. Textiles reinforced with this technical colour print, are simultaneously lightweight and sturdy, flexible and abrasion resistant. The technique turns the formerly purely decorative paint into a functional, architectural structure.

### AESTHETIC TRANSFORMATION

#### VAPOUR Light

Studio Thier&vanDaalen, 2016

A fascination for movement of structures in nature and the contrast between geometric and organic shapes inspired this light sculpture. By twisting or pulling the flexible outer nylon fabric skin, a wide variety of shapes can be created, and colours and light intensity can vary as desired.

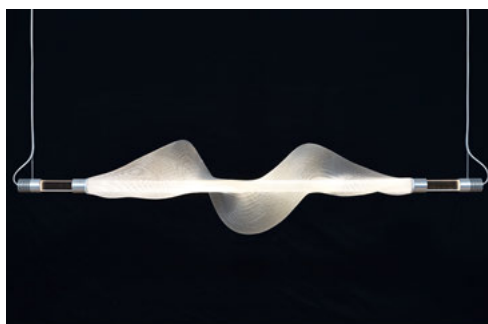

Vapour – a play of light and form

### 3D PRINT – AUXETIC MATERIAL

Eric Esser, product designer M. A., 2017

AuxTex is the combination of an auxetic structure with flexible, rubber-like TPE plastic. Through the synthesis of geometry and material, the textile is very light, smooth and flowing, air permeable, resilient and able to expand to twice its size under tension. Stretchable materials usually become longer and thinner under tension, but auxetic materials become longer and thicker when stretched. The material offers diverse application possibilities: from textiles in the fashion sector to part of an orthosis in medical technology, as protection or crumple zone material in the automotive sector to structural uses in architecture.

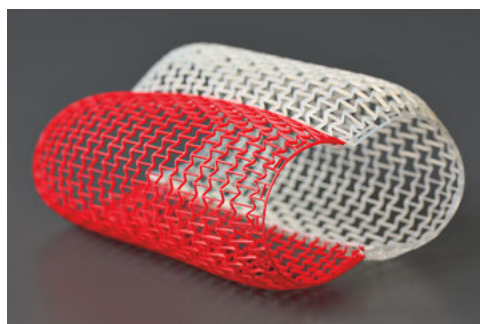

AuxTex – auxetic 3D printing

### INTELLIGENT MATERIALS

#### Jacquard – Smart Wearables

Google ATAP Team, 2014–2017

The development of conductive yarns and fabrics makes it possible to integrate functional control elements into clothing. Connectivity and interactivity are literally woven into items of everyday life. Electronics serves here as a bridge between the physical and the digital for on-the-move applications such as electronic communications, navigating the city and listening to music. The Levi's Jacquard jacket understands a range of touch gestures and can activate digital services or provide feedback as haptic or light signals. It is only a small step from garments to similar applications in interior design.



Jacquard Smart – touch-sensitive materials



Self-growing chair – Bio-tiful



Berlin House of the Future – Bio-tecture

### NEW MINDSET – OLD MATERIALS AND NEW APPROACHES: BIO-TIFUL

#### *Plant yourself a chair*

Studio Werner Aisslinger, 2012

Do it Yourself by Nature – a production utopia of the future that is as simple as it is radical. Fast-growing bamboo is trained to grow within a steel corset to produce a naturally grown chair – a new way to claim back furniture production from globalised serial manufacturing to resource-conserving local production.

### SOLI – SENSOR TECHNOLOGY AND TOUCHLESS RADAR GESTURE RECOGNITION

Google ATAP Team, 2015

Operations such as pressing, turning and pushing will, in the future, be made possible by Soli without the need for any mechanics – Soli uses radar to render the touchscreen superfluous. This kind of intuitive touchless operation is also suitable for analogue thinking people.

### FASCINATION FUTURE

#### *Living plant constructions*

House of the Future Berlin, Dr.-Ing. F. Ludwig/  
D. Schönle, 2012

Baubotanik structures form living, changing facades that are an integral part of the building's climatic concept both inside and outside. Over the course of the seasons, it reveals different aesthetic and ecological benefits: it is shady in summer, colourful in autumn, transparent in spring and bright in winter. The construction consists of several trees whose branches intertwine and grow together into one large organic scaffold, improving its stability while retaining its overall basic geometry.

These various developments, approaches and strategies show that the transformations and inventions awaiting us are both fascinating and challenging. Seen from a holistic perspective, we may be able to identify innovative possibilities that arise at the intersection of separate aspects, or through their connection and combination.

The conception of a flexible outer skin for vehicles, the idea of growing a chair or even an entire facade or the possibility of controlling complex equipment with hand gestures alone, show that what we can achieve in the future is held back only by the limits of our imagination.

The upcoming emotional, social and technical questions are about further development, change and dynamics.

What direction will developments in materiality take in the future?

Which processes make the previously unthinkable conceivable?

Which new perspectives do we need to conquer? And how can we think ahead and turn visions into positive reality for everyone?

## ■ 1.2 CFRP structures: Uses in aviation – applications in architecture

Carsten Schmidt



Automated manufacture of an A350 side panel by Premium Aerotec using Automated Fibre Placement

Fibre composite structures, especially those based on carbon fibre reinforced plastics (CFRP), are used extensively in aircraft construction for the primary and secondary structure. Prominent examples include the Airbus A350 XWB and the Boeing 787 Dreamliner, where fibre-reinforced materials make up half their structural weight. They are used for load-sustaining parts such as wing and fuselage structures, and the stabiliser.

The popularity of CFRP structures among aircraft engineers can be attributed to their excellent weight-specific strength and stiffness properties. The combination of plastic matrices and reinforcing fibres transmits forces through the interaction of adhesion and cohesion within the structure. By varying the fibres used (HAT, HM, UHM), the fibre orientation within the structure (isotropic and anisotropic, i.e. direction-dependent and direction-independent) and the matrix materials (e.g. thermoplastic or thermosetting plastics), the properties of CFRP structures can be adjusted to serve a wide range of applications. This is a product of the layered generative composition of fibre-reinforced materials, which in the aircraft industry is predominantly produced using highly automated systems.

### Hybrid material concepts

Alongside pure CFRP structures, variants that combine the advantages of fibre-reinforced and metallic structures also exist. Fibre-metal laminates are an example of such hybrid composites. The fuselage of the Airbus A380, for instance, is partly built from multilayer glass-fibre-aluminium layers. This addi-

tional hybridisation step gives the material excellent damage tolerance as well as fire resistance properties, further increasing component reliability. Used locally, hybridised structural areas also improve the ability of high-performance fibre composites to absorb large loads from adjacent structures. The form and materials of the individual thin metal layers of the intrinsic hybrid composites can be specifically tailored to the expected stress and desired damage behaviour. The damage behaviour can also be improved by using elastomer layers instead of metal layers, which increase the impact strength of CFRP structures. Elastomer layers are suitable for passive damping in fibre composite structures to reduce sound radiation.

### Applications in architecture

In architecture, the usage of carbon fibre reinforced plastics is still very limited due to the high costs of the material. Glass fibre reinforced plastics are, however, widely used, for example for large facade panels on building fronts. A famous example is the large “tuning forks” of the Elbphilharmonie building in Hamburg. The spherically curved facade elements consist of a composite of the GFRP “tuning fork” and a three-dimensionally curved glass pane. With heights of up to 5 m, they cover 16,000 m<sup>2</sup> of the building’s facade.<sup>1</sup>

### GFRP

The largely self-supporting properties, high strength and rigidity of glass fibre reinforced plastics makes them highly suitable in combination with glass. The

composite system makes it possible to produce large areas of glazing with barely visible frame constructions. The presence of glass fibres in the GFRP means that it exhibits the same thermal expansion behaviour as the glass pane. By scattering light, the translucent facade panels create a varied surface effect and also make a significant contribution to the energy balance by reducing the energy required for heating and lighting.

### CFRP

At present, there are far fewer solutions that make use of carbon fibre reinforced structures. Most are conceptual in character or are employed for trend-setting architecture.

An example of a practical application of carbon fibre reinforcement is Apple’s Steve Jobs Theater in Silicon Valley.<sup>2</sup> The roof of the theatre building is currently the world’s largest self-supporting carbon roof construction and covers an area of 1,734 m<sup>2</sup> with a diameter of 47 m. Made of carbon fibre reinforced plastics, the 44 roof segments weigh only 80 tons and appear to float on the loadbearing glass walls of the theatre.

Novel manufacturing processes for fibre composite structures that draw inspiration from nature have made formwork-free buildings possible.<sup>3</sup> The architecture of the ICD/ITKE research pavilion in Stuttgart was modelled on the hardened forewing (elytron) of certain flying beetles.<sup>4</sup> The structure made of carbon fibre and glass fibre segments illustrates how interdisciplinary collaboration between architects, civil engineers and production



CFRP fuselage shell of an Airbus A350

technicians can give rise to completely new structural and production concepts.

#### Shape-changing materials: Inspiration from aircraft construction

Hybrid material concepts comprising zones of rigid, fibre-reinforced duromers and flexible elastomers make it possible to control the active deformation and therefore movement of structures. The morphing leading edge aerofoils<sup>5</sup> in wing structures are an example of this. Here, the soft elastomeric intermediate layers allow greater degrees of deformation by reducing the elastic restoring forces.

#### Controlled deformation

By means of integral actuators in the wing, for example electrically driven levers or piezo foils in the structure, the wing profile is adapted to better match the aerodynamic requirements of the different flight phases. A closed wing surface improves aerodynamics and reduces noise in flight. Inspired

by nature, the trailing edge of the wing has pneumatic actuators like the Venus flytrap (*Dionaea muscipula*).<sup>6</sup> The plastic cells of the landing flap deform when subjected to different pressures in a manner similar to the activation of the closing mechanism of the flytrap when the leaf cells are subjected to pressure. At slow flight speeds, the flap can help to increase the curvature of the wing, raising the lift coefficient to compensate for the loss of speed. Since the entire contour of a wing has an effect on the air forces, morphing concepts that affect the entire wing cross section also exist. Based on a herringbone pattern, the wing structure can deform along its "spine".<sup>7</sup> Applying tension to one of a pair of tendons running above and below the spine causes an upward or downward movement of the structure. By increasing the number of actuators, more specific wing cross sections can be created. A morphing aerofoil with five degrees of freedom is achievable using integral ultrasonic piezo motors.<sup>8</sup> These move on a flexible traverse and shift the force

transmission points of the inner supporting structure, causing the outer shell of the wing to deform. Bistable deformation mechanisms are a special form<sup>9</sup> achieved by an asymmetrically designed layering within the CFRP structure. During curing, this leads to distortion deformations due to internal stresses. Two or more deformation states occur at which the internal stresses balance each other. A primary advantage of bistable mechanisms in comparison to conventional actuators is that no power is required to maintain the deformation. Piezoceramic actuators, or similar, are only required to effect the change between equilibrium states.

#### Situational deformation

In addition to active, controlled deformation, structural solutions that are capable of automatically adapting to environmental conditions by changing their shape also exist.<sup>10</sup> These are used, among other things, to provide passive load relief to the wings under aerodynamic loads. To achieve this,



Fiberline's pultruded Lay Light profiles were used at the Serpentine Pavilion 2016, BIG (Bjarke Ingels Group), Kensington Gardens, London.

cellular structures in the core of the wing form an inherent mechanism, which allows the adjustment of stiffness and flexibility in accordance with the materials used and the geometry and arrangement of the cells. In response to the structural load resulting from fluid-structure interaction, the wing deforms in a targeted manner, relieving the load on the structure through deformation.

### Suggestions for architecture

Research in the field of aircraft construction has given rise to promising approaches that can also be applied to architecture. For example, shape-changing facade elements could be used as shading systems to help regulate the incidence of light according to need. Alternatively, facade elements could be used to generate energy by optimally aligning integral photovoltaic modules to the direction of the sun. Building facades could also employ structures modelled on fish gills, with variable openings that could act as a passive ventilation system that adapts autonomously to the building climate and wind conditions. An example of this is the One Ocean Pavilion at the EXPO 2012 in South Korea.<sup>11</sup> Its kinetic facade comprises 108 GFRP lamellas of between 3 and 13m in height. The bending of the lamellas causes them to change shape, creating

ventilation openings and sunshading louvres, while its flowing movement also regulates the need for light in the building.

Such examples make optimum use of the specific mechanical properties of fibre composite structures, which can be influenced in the manufacturing process. To construct buildings that draw inspiration from nature for the future, architects, civil engineers and production technicians must show the courage to employ new materials and function-integrated elements and to jointly push forward the boundaries of the possible.

- 1 Mack, G.: *Herzog & de Meuron – Elbphilharmonie Hamburg*, Basel, 2018, p. 194.
- 2 Foster + Partners, [www.fosterandpartners.com/projects/steve-jobs-theater/#construction](http://www.fosterandpartners.com/projects/steve-jobs-theater/#construction), accessed on 07/06/2018.
- 3 Centgraf, S.: "Schalungslose Faserverbundwerkstoffe. Forschungspavillon ICD/ITKE, Stuttgart", *DBZ Deutsche Bauzeitschrift*, 62 (7), 2014, pp. 50–55.
- 4 Ibid.
- 5 Rudenko, A.; Hannig, A.; Monner, H. P.; Horst, P.: "Extremely deformable morphing leading edge: Optimization, design and structural testing", *Journal of Intelligent Material Systems and Structures*, 29 (5), 2018, pp. 764–773.
- 6 Gramüller, B.: "On Pressure-Actuated Cellular Structures", PhD thesis, Technische Universität Carolo-Wilhelmina zu Braunschweig, 2016.
- 7 Shaw, A. D.; Dayyani, I.; Friswell, M. I.: "Optimisation of composite corrugated skins for buckling in morphing aircraft", *Composite Structures*, 119, 2015, pp. 227–237.
- 8 Wu, R.; Soutis, C.; Zhong, S.; Filippone, A.: "A morphing aerofoil with highly controllable aerodynamic performance", *The Aeronautical Journal*, 121 (1235), 2017, pp. 54–72.
- 9 Bilgen, O.; Arrieta, A.; Friswell, M.; Hagedorn, P.: "Dynamic control of a bi-stable wing under aerodynamic loading", *Smart Materials and Structures*, 22 (2), 2013.
- 10 Heo, H.; Ju, J.; Kim, D.-M.: "Compliant cellular structures: Application to a passive morphing airfoil", *Composite Structures*, 106, 2013, pp. 560–569.
- 11 Marboe, I.: "Biomimetischer Wellenschlag. Themenpavillon EXPO 2012, Yeosu/KR", *DBZ Deutsche Bauzeitschrift*, 60 (9), 2012, pp. 32–39.



1

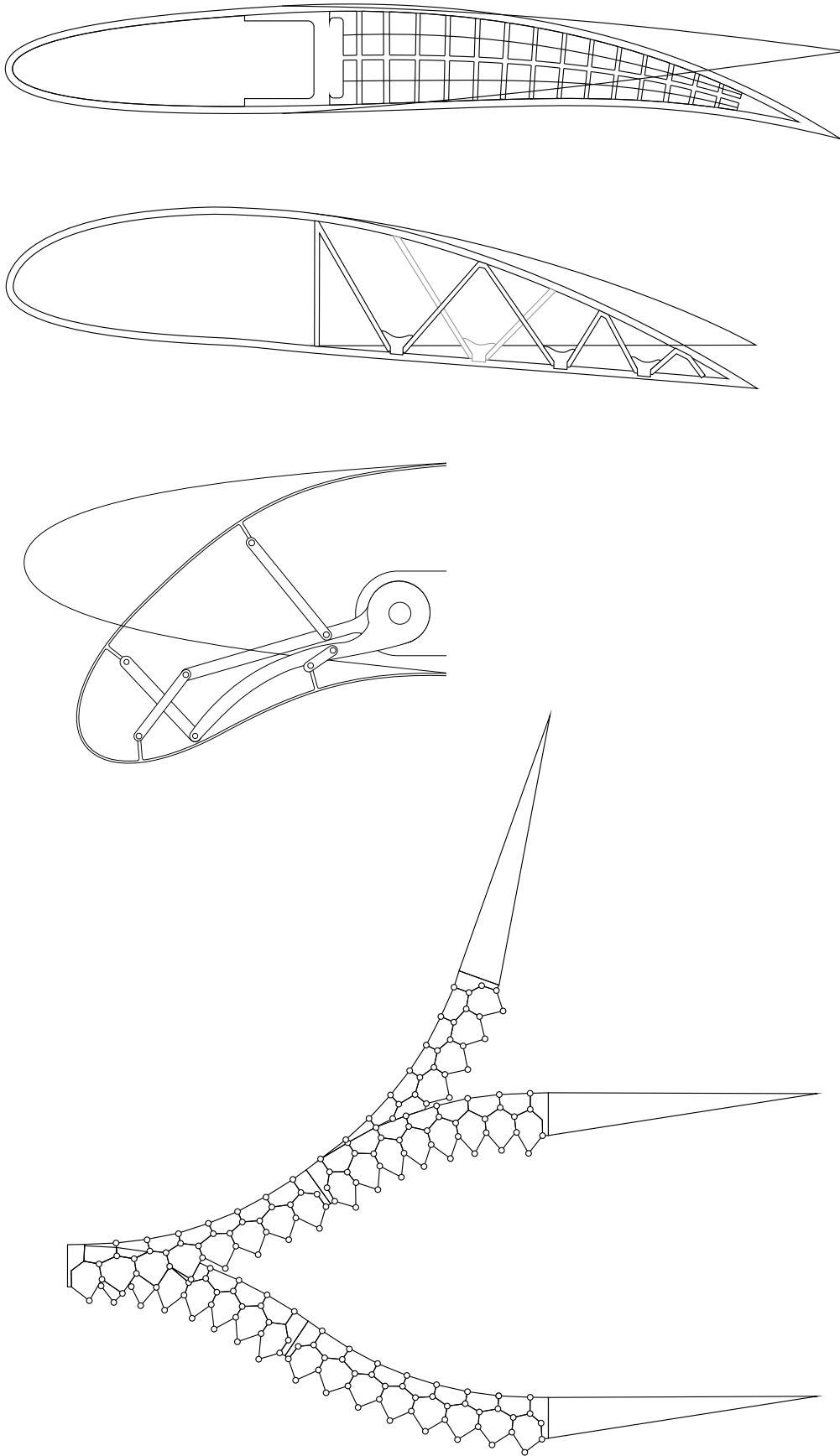

A morphing aerofoil allows an aircraft wing to adapt to the different phases of flight and their corresponding aerodynamic requirements (from top to bottom): using cable pulls,<sup>7</sup> pneumatic actuators,<sup>6</sup> ultrasonic piezo motors<sup>8</sup> and electro-mechanical actuators<sup>5</sup>.

### ■ 1.3 Textiles in motion

Sara Nester, Shankar K. Jha



“Slow Furl” installation: a textile membrane on a wooden framework that serves as an interactive interior skin, developed by Mette Ramsgard Thomsen, Karin Bech and Sofie Aandahl, CITA, Royal Danish Academy of Fine Arts, 2008

Flexibility, lightness and adaptability: these characteristics are the reasons why we wear fabrics and textiles every day as a second skin on the body. The body changes permanently, forming new geometries, to which a textile adapts due to the way it lies, hangs and drapes. Despite also fulfilling other functions, such as protecting the skin or keeping us warm, textiles still afford us maximum freedom of movement. This natural symbiosis between carrier structure and textile may at first seem trivial, but it certainly justifies considering the use of textiles for other dynamic problems. To better grasp its potential for the construction of movable architectural components, it is useful to first examine established applications, and to then identify the properties and innovations that qualify textiles for use in architecture. These can then help us to understand their potential for use in movable architectural components.

#### Textiles and space

Textiles are typically used in rooms as a design element, which through their structure and form make a room more comfortable. They can also be used as a delimiting element, as a vertical boundary in space that is flexible and easy to move, and that can create a defined space within a room without having the finality of a door or a wall.

But their use is not purely to divide or delimit space; they can also enclose and form space in their own right. In a tent, textiles serve as flat bounding surfaces that separate inside from outside and create a temporary space within. They are made taut under tension using a supporting mechanical struc-

ture or by pneumatic means so that they can form stiff, loadbearing structures. Compared with conventional masonry walls, textile structures are simple to erect and very lightweight, and even very large spans are easy to transport and quickly built. Examples of such dynamic constructions range from a two-person tent to a textile facade or entire roof structures. As a composite material in combination with other materials, textiles can also be used in space-defining elements: textile reinforcement in concrete, for example, makes thin-walled, lightweight components possible.

#### Material qualification and innovation

These applications are made possible by the remarkable diversity and versatility of the material. Different fibre materials, production techniques and post-processing methods can be combined to meet the specific demands of the respective application. Textiles offer countless possibilities in terms of structure and design, and by varying the density and production method of the textile, the degree of light transmission and sound absorption can be precisely controlled.

In addition to their visual and tactile qualities, textiles are also increasingly fulfilling ever more invisible requirements. Various post-treatment methods have made textiles more resilient and easier to maintain: textiles are now available that are wrinkle-free, stain-resistant, fast-drying or even self-cleaning. This last involves treating the surface with modern nanotechnologies that cause liquids to run off the material surface. As the water droplets

roll off, they take dirt particles on the surface with them, making it possible to wash them clean without mechanical effort.

Such technologies are a factor of the high innovation potential of textiles, which have been the focus of ongoing development for decades. New fibre and surface modifications enable textiles to withstand aggressive environmental conditions. Textiles with good physical and chemical resistance can prolong the lifetime of the components in which they are used. But more than anything, it is the high tensile strength of textiles and their comparatively low weight per unit area that make them the ideal material for stable, high-performance lightweight constructions.

Textiles are also highly compatible with other materials, which makes it possible to equip them with further functions as composite materials. Yarns with conductive or fluorescent properties as well as electronic hardware can be incorporated into the structure of textiles. Alongside heated or illuminated textiles, membranes with integral flexible thin-film solar cells have therefore also begun to make inroads into architecture.

#### Textiles in motion

As stated at the outset, textiles are predestined for clothing due to the high freedom of movement they afford. Movement, and thus changes in geometry, leads to wrinkling, stretching and friction. The drape characteristics and suppleness of textiles, combined with their high tensile strength, enable them to withstand such mechanical stresses. The



Textile used as a design and sensitive element in space, Slow Furl Installation, Royal Danish Academy of Fine Arts, 2008

energy required to move is also a factor of the weight to be moved: the lighter the clothing, the better the wearing comfort. By the same token, the relatively low weight per unit area of textile makes them suitable for moving constructions by reducing the total weight to be moved and thus the energy required. Typically, a foldable textile membrane is stretched over a carrier construction. The carrier construction moves actively, while the textile only moves with it. This principle applies equally to a parasol as it does to a stadium roof construction. An interactive variant of this principle is the "Slow Furl" project by Mette Ramsgaard Thomsen at the Centre for Information Technology and Architecture in Copenhagen. It is a room-sized textile installation that moves gently and fluidly. Sensors on the textile surface detect movements in the vicinity causing the wooden skeleton of the underlying construction to react with slow mechanical movements that the textile skin then reflects. The result is the illusion of a flowing, breathing surface.

### Interactive materials

If, in contrast to this skeleton membrane principle, the material textile itself is the dynamic, interactive element, new possibilities arise for the construction of movable components. One approach involves so-called self-activating textiles. Such materials employ technologies that enable reversible and reproducible property changes. They activate independently in response to changing environmental influences, bringing about specific changes in shape, colour or light transmission. Shape Memory Materials (SMMs) are an example of this. They change their shape in response to vari-

ations in temperature (Shape Memory Alloys, SMA) or temperature, light and humidity (Shape Memory Polymers, SMP). When an influencing variable exceeds a certain threshold, the material returns from its temporary state back to its predetermined initial state without any external force being applied. Its ability to respond independently obviates the need for a pneumatic or mechanical carrier construction to effect the movement. Further new possibilities include the design of an adaptive textile facade that opens and closes depending on temperature, regulating the indoor climate of the rooms inside without additional energy expenditure.

Architect Doris Sung has realised such structures employing the functionality of thermobimetals. These are not SMMs, but a composite of two different metal layers with different coefficients of thermal expansion. As the bimetallic elements warm up, they bend to a predictable degree. The effect is reproducible and temporary, making it possible to use them to construct a thermoregulated facade. The advantageous properties of SMPs with respect to light control, weight and flexibility allow for textiles that could be used to significantly improve the functionality of building structures.

### Reference literature

Cremers, Jan: "Integration von Photovoltaik in Membrankonstruktionen", *DETAIL Magazin*, 2009, [www.detail.de/artikel/integration-von-photovoltaik-in-membrankonstruktionen-1618/](http://www.detail.de/artikel/integration-von-photovoltaik-in-membrankonstruktionen-1618/), accessed on 02/04/2018.  
Fritz, Susanne (ed.): "Bau-Stoff: Textile Architektur 1", *Architonic*, 2011, [www.architonic.com/de/story/susanne-fritz-bau-stoff-textile-architektur-teil-1/7000625](http://www.architonic.com/de/story/susanne-fritz-bau-stoff-textile-architektur-teil-1/7000625), accessed on 02/04/2018.

Grunwald, Gregor: "Mechanisch vorgespannte, doppellagige Membranmodule in ihrer Anwendung als zweite Gebäudehülle", PhD thesis, TU Berlin, 2007.  
Hu, Jinlian: *Shape Memory Polymers and Textiles*, Cambridge, UK, 2007.  
Koch, Klaus-Michael: "Renaissance im Bauen mit Membranen", in: Knecht, Petra: *Technische Textilien*, Frankfurt am Main, 2006.  
Krüger, Sylvie: "Textile Architektur – damals und heute", *Modulor Magazin*, 3, 2011.  
Mattila, H. R. (ed.): *Intelligent textiles and clothing*, Cambridge, UK, 2006.  
Motro, René (ed.): *Flexible Composite Materials in Architecture, Construction and Interiors*, Basel, 2013.  
Meyer-Storck, Sebastian: "Forschungsaufgabe technische Textilien", in: Knecht, Petra: *Technische Textilien*, Frankfurt am Main, 2006.  
Mustafina, Diana: "Doris Sung: The Art of Architecture Inspired by Biology", 2017, Yonah Fund, <http://yonah.org/channel/doris-sung-art-architecture>, accessed on 18/12/2018.  
Pohl, Goeran (ed.): *Textiles, polymers and composites for buildings*, Cambridge, UK, 2010.  
Ramsgaard Thomsen, Mette: "Textile Logics in a Moving Architecture", Transitive Materials Workshop, Royal Danish Academy of Fine Arts, 2009.  
Royer, Andreas et al.: "Textilbewehrter Beton", in: Knecht, Petra: *Technische Textilien*, Frankfurt am Main, 2006.  
Griffith Winton, Alexa; Schneidermann, Deborah (eds.): *Textile Technology and Design: From Interior Space to Outer Space*, London, 2016.  
Sobek, Werner; Speth, Martin: "Von der Faser zum Gewebe, Textile Werkstoffe im Bauwesen", *Deutsche Bauzeitung*, 127 (9), 1993, pp. 74–81.  
Sobek, Werner: "Wandelbare Überdachungen aus textilen Werkstoffen", Internationales Techtexil-Symposium 1993, 4.2: Textiles Bauen, neue Textilarchitektur, Frankfurt, 1993, pp. 1–6.  
Xu, Han: "Clothing and Architecture: more in common", 2004, [http://www.tboake.com/competitions/comp\\_essays/hxu-essay.pdf](http://www.tboake.com/competitions/comp_essays/hxu-essay.pdf).



The *Strelitzia reginae* served as biological inspiration for the Flectofin®

## ■ 1.4 Bio-inspired elasticity

Jan Knippers, Axel Körner

Adaptive and movable building envelopes are usually made either of rigid elements or of flexible textiles made mobile using hinges, rollers and joints. In most cases, these mechanically complex systems move along a linear or rotational axis, which places corresponding geometric limitations on the design. In addition, mechanical shading systems realised in this manner are susceptible to the weather and, in harsh climates, can only be installed behind glazing.

By contrast, we need only look to nature to see numerous motion mechanisms that are based on the elastic bending of fibrous materials and are also extremely robust. These “compliant mechanisms” have the potential to reduce the mechanical complexity of moving parts while offering a variety of complex and efficient motion principles that seem more suited to the application of architecturally complex forms.

Apart from technical advantages, elastic mechanisms also offer interesting design possibilities. While most technical applications involve rigid parts that shift or rotate with respect to one another, flexible mechanisms often require only a small actuating impulse to trigger a complex, three-dimensional change in shape that, while not as obvious to the viewer as typical hinged-joint mechanisms, nevertheless registers as plausible. In biology, such motions are the product of local adaptations of material properties, which have the added advantage of avoiding high stress concentrations.<sup>1</sup>

### Abstraction principle and methodology

For the development of the first prototypical biomimetic mechanisms, a methodology was developed at the Institute of Building Structures and Structural Design (ITKE) at the University of Stuttgart to abstract specific biological properties for use in architecturally relevant technical applications. Using kinematic and kinetic models, the team identified and classified the geometric and physical parameters that influence the different motion principles. The corresponding material and geometric properties were then tested in physical prototypes. Specific individual bio-inspired motion mechanisms, or combinations thereof, were then elaborated for use in concrete applications.<sup>2</sup>

### Flectofin®

The Flectofin® was one of the first biomimetic shading elements developed at ITKE to employ the principle of elastic deformation. Biological inspiration came from the bird of paradise flower (*Strelitzia reginae*). When a bird alights on the end of the flower’s stalk, the petals attached to the stalk open sideways, exposing the pollen so that it adheres to the bird, which then carries it to the next flower. The relevant principle of motion for a technical application can be represented in simplified form as a rod to which a thin blade-like fin is attached. When the rod bends, the fin folds to one side – a phenomenon known in traditional structural analysis as torsional buckling failure that should usually be avoided at all costs. In the biological situation, however, this buckling behaviour is used to actuate

a larger deformation with a small force. What is more, it is reversible and repeatable – several thousand times over – without damage. For the development of the Flectofin® facade shading device, this principle was scaled to an architecturally relevant scale and constructed from glass fibre reinforced plastic (GFRP). Applying a force leads to a relatively low bending deformation of a stiff, rod-shaped element and, as in the flower, triggers a lateral folding motion.<sup>3</sup>

### One Ocean Pavilion

The analysis of natural motions based on elastic deformation also led to the development of the kinetic facade of the One Ocean Pavilion at the EXPO 2012 in Yeosu, South Korea, designed by some architecture. The facade consists of 108 GFRP slats of between 3 and 13 m in height. Linear actuators apply a unidirectional compressive load to the upper and lower ends of the slats, causing elastic deformation in the slats so that the surface of the facade opens and closes. The slats can be controlled individually, both to variably control lighting conditions in the interior and to animate the facade through choreographed motion patterns.<sup>4</sup>

### Flectofold

The material construction of the Flectofin® leads to comparably high stresses at the transition from rod to fin, requiring high actuating forces. The development of the Flectofold attempts to avoid this, drawing once again on biological models, this time with discrete elastic joint zones.

The waterwheel plant (*Aldrovanda vesiculosa*) is an aquatic carnivorous plant with approx. 5 mm wide snap traps comprised of two curved half-shells. These are connected to a central rib by curved folds of a thinner material thickness. When the plant's prey comes into contact with the plant, it causes the central rib to bend. This comparatively slight change in curvature leads to an accelerated folding motion in the flaps, which close as a result, trapping the prey.

The underlying principle of motion can be abstracted into a curved-line folding model, in which two somewhat stiffer flaps are connected by local joint zones with lower bending stiffness to a stiffened lenticular middle rib.<sup>5</sup> During the folding process, the two flaps are bent along the curved folding line. A relatively small bending curvature in the midrib thus leads to an increased folding motion of the flaps connected via the joint zone. The principle of folding serves to amplify the motion.

To realise the integral joint zones of the Flectofold and to ensure its continued damage-free operation for numerous bending cycles, elastomer foils were used in combination with glass fibre mats for the

blades and rib. The bending actuation is provided by a pneumatic cushion that is mounted between the lenticular middle rib and the supporting sub-structure and requires air pressure of just 0.3 bar.<sup>6</sup>

A prototypical section of a Flectofold facade built for the exhibition "Baubionik – Biologie beflügelt Architektur" in the Natural History Museum in Stuttgart demonstrates its application in architecture on a curved surface. For this purpose, a hyperbolic paraboloid framework was equipped with 36 Flectofolds, which could be actively and individually controlled by a web-based user interface that actuates the shading elements with the aid of proportional pressure valves and pneumatic cushions.

### Conclusion

These bio-inspired shading systems illustrate the potential of research into biomimetic for the development of innovative technical applications that not only have a positive impact on quantifiable aspects such as the control of solar radiation, but also open up new possibilities for the design of complex motions and their choreography.

- 1 Lienhard, J.; Schleicher, S.; Poppinga, S.; Masselter, T.; Milwich, M.; Speck, T.; Knippers, J.: "Flectofin – a hingeless flapping mechanism inspired by nature", *Bioinspiration & Biomimetics*, 6 (4), 2011; Knippers, J.; Speck, T.: "Design and construction principles in nature and architecture", *Bioinspiration & Biomimetics*, 7 (1), 2012; Poppinga S.; Körner, A.; Sachse, R.; Born, L.; Westermeier, A. S.; Knippers, J.; Bischoff, M.; Gresser, G. T.; Speck, T.: "Compliant mechanisms in plants and architecture", in: Knippers, J.; Nickel, K.; Speck, T. (eds.): *Biomimetic Research for Architecture and Building Construction*, Cham, Switzerland, 2016, pp. 169–193; Körner, A.; Born, L.; Mader, A.; Sachse, R.; Saffarian, S.; Westermeier, A. S.; Poppinga, S.; Bischoff, M.; Gresser, G. T.; Milwich, M.; Speck, T.; Knippers, J.: "Flectofold – A biomimetic compliant shading device for complex free form facades", *Smart Materials and Structures*, 27 (1), 2018.
- 2 Schleicher S.: "Bio-inspired compliant mechanisms for architectural design – Transferring bending and folding principles of plant leaves to flexible kinetic structures", PhD thesis, University of Stuttgart, 2016.
- 3 Lienhard et al. 2011.
- 4 Knippers et al. 2013.
- 5 Schleicher 2016.
- 6 Körner et al. 2018.



Flectofold large-scale demonstrator for the "Baubionik – Biologie beflügelt Architektur" exhibition in the Natural History Museum in Stuttgart, Schloss Rosenstein



Flectofin® demonstrator

## ■ 1.5 Urban cable cars as dynamic elements in the city and as architecture

Laura Kienbaum

A cable car ride is, in a sense, a dematerialised form of travel – a sensation of noiseless, remote-controlled floating. While cable cars have until now served mainly as a means of reaching elevated points in mountainous landscapes and for tourism, their speed, the view they afford and the somewhat fleeting “panoramic” experience they offer make them increasingly attractive as an unusual and special means of everyday transport in urban areas. The cabin as the space that moves and surrounds the passenger during the journey is both a vantage point and a point of attraction as it moves continuously through the air. The end stations and intermediary stops are likewise part of the experience. A cable car system can therefore be defining for a city’s image, choreographing the movement of people, and serving as inspiration for new approaches to architecture and dynamic concepts in the city.

### Designing movement

The architecture of cable car systems includes stations, masts and the cabins that traverse the landscape or urban space. While cableway components such as the masts and cabins rarely fall within the architect’s scope of responsibility, the station buildings do. Their architectural variety knows few bounds: some are solid and weighty, others delicate and filigree, some are demonstratively technical and others dramatically artistic. They represent their location as well as the technology, and consequently some are more functional and others more expressive. To discuss the interactions and interdependencies between architecture and movement, it is first

useful to identify the typological characteristics and main design elements of cable car stations.

The requirements and defining factors of cable car station architecture are determined on the one hand by technical aspects such as the drive and tensioning mechanisms, the so-called station equipment, and on the other hand by functional elements such as platforms, entrances and exits, and control rooms. All these determine the space requirements, the routing of passenger flows and the organisation of the programme of spaces.

In its most elementary form, a station building comprises a roof and three sides, with the fourth side open for the cabins to enter and exit. This basic type exists in all manner of variants, usually with regard to the degree of openness and the building form.

The station controls the flow of passengers from the urban surroundings through the station to the cabins. There are two primary routing systems: compact access systems and two- or three-way systems that carefully organise the flow of people.

The different parts of the programme are typically organised across several cut-out levels. Aside from the core facilities, many cable car stations are combined with other programmes, which may be more or less closely related to their primary function.

With the exception of these primary characteristics and key building blocks, designers are comparatively free in deciding how they wish to respond to the context of the respective location or wish to express the theme of movement. The following case study illustrates how the basic building blocks can be adapted to fit a specific context.



Portland Aerial Tram, the city’s new cable car, designed by the architecture firm agps, serves as a “floating corridor” between two university hospital complexes.

### The floating corridor

In the North American city of Portland, Oregon, a cable car was built in 2006 to connect two functionally related building complexes. A planned extension to the university hospital made it necessary to establish a direct and fast connection between two campus sites. What sets this project apart from an architectural standpoint is that the cable car functions as a corridor but is simultaneously an independent piece of infrastructure. This duality is in part a product of the fact that the architects were responsible not just for the design of the station buildings but also for the cabins and masts, creating a coherent overall design. In addition, the station buildings connect both programmatically and choreographically with the existing buildings.

The valley station of the Portland Aerial Tram is designed as a pavilion with a ground level entrance platform, which is kept free of any enclosed rooms. It comprises primarily two concrete vertical slabs that serve both as the cable anchorage and as the footing for the elevated control centre, which is housed in a red box on the level above. The open station area is enclosed only by a semitransparent expanded metal mesh shell, which extends as a folded, polygonal surface across the 14m high roof and two long sides of the station, but not down to the ground. The only boundary in the direction of travel is the cut-out in the ground to allow the cabin floor to end flush with the pavement. The pavement-level entry, the lack of barriers or buildings at ground level, and the tunnel-like orientation of the station envelope allow public space to flow



The valley station is an open pavilion seamlessly connected to the public realm.



Ground level entry allows pedestrians to step from the pavement into the cable car.



The mountain station is a freestanding tower connected to the existing hospital buildings by a glass bridge.

seamlessly into the station and passengers to step directly from the public realm into the cable car. In addition, the context of the neighbouring clinic buildings is directly visible.

The two cabins of the cable car are likewise special in terms of their unusual curved shape and material quality. Featuring bodywork of curved aluminium sheets and perimeter glazing mounted on the steel frame, the seamless panel joins give the cabin a smooth, monolithic appearance. A special coating ensures that incident light is reflected rather than heating up the interior, with the windows virtually acting as mirrors. When in motion, the cabins float almost like soap bubbles through the air; they look elegant and contemporary, and quite different from their alpine brethren. The cableway begins by rising rapidly to a height of 70m to pass over a traffic highway. The interim mast – the only mast of the entire cableway – is visible from far and wide and correspondingly striking in appearance. A single column, compact in its construction, extends at an angle of 90° to the cable and has an extravagant profile that tapers upwards before spreading again at the top. Its matt-reflective and metallic surface denotes that it belongs to the cableway construction. On the way up, passengers have a panoramic view over the surroundings in the distance, with the direct view downwards onto private property obscured by the curvature of the cabin and a special glass coating that acts as a screen.

The journey to the mountain station is over in three minutes. The station shares similar design characteristics with its counterpart in the valley but takes

the form of a separate tower on the sloped terrain that stands in front of an existing building of the hospital complex. The platform is arranged at the same level as the public area of the clinic and is reached via a glazed bridge. The route from the station has several stages: first the bridge, then a passage through the clinic and finally a ramp from the rear of the existing building. The new structure is woven directly into the existing complex, allowing passengers to share the facilities of the public service area of the hospital. All the cable car structures are distinct buildings in their own right but are legible as a whole. They express the dynamism of the mode of transport and act as a signature element for the city. Both end stations are programmatically and choreographically woven into the respective context of the clinic sites and, almost as parasites, tap into the existing infrastructure.

The architectural approach of the project – and the conscious design decisions with regard to the three building blocks of the end points, path and programme – makes the experience of the cable car an almost seamless part of the urban realm, a corridor-like passage from A to B and B to A that is used daily by doctors, patients and visitors to the clinic.

#### Urban transformations

There are many other examples that show further facets and benefits of urban cable cars for cities and architecture. Cable cars can make entire districts of a city accessible and be coupled together to form extensive transport networks. They change both the way people move around in cities as well as how

they experience the city. In combination with other functions, cable car stations can act as hybrid locations, with public authorities, cultural, sports and social facilities. As such they become public hubs in the city connected to each other by the cable car cabins. The mix of functions brings together different people, promoting social interaction and informal activities, and fostering an urban character that radiates into the surrounding urban quarter. Through their unavoidably striking presence in the urban realm, their moving components (the cabins) and their specific contextual manifestation, cable car systems have the capacity to quickly become part of the collective memory of a city and its visitors. They are a symbol of spatial interconnection and a sustainable means of urban transport.



Theory and  
planning

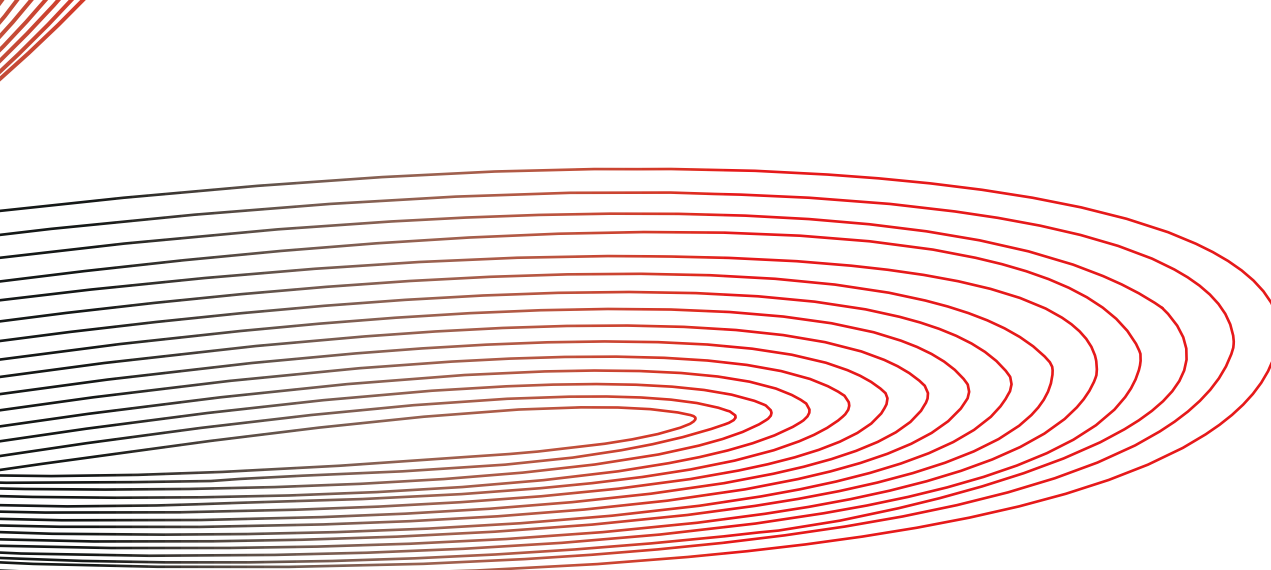

2

Movement  
and construction  
principles

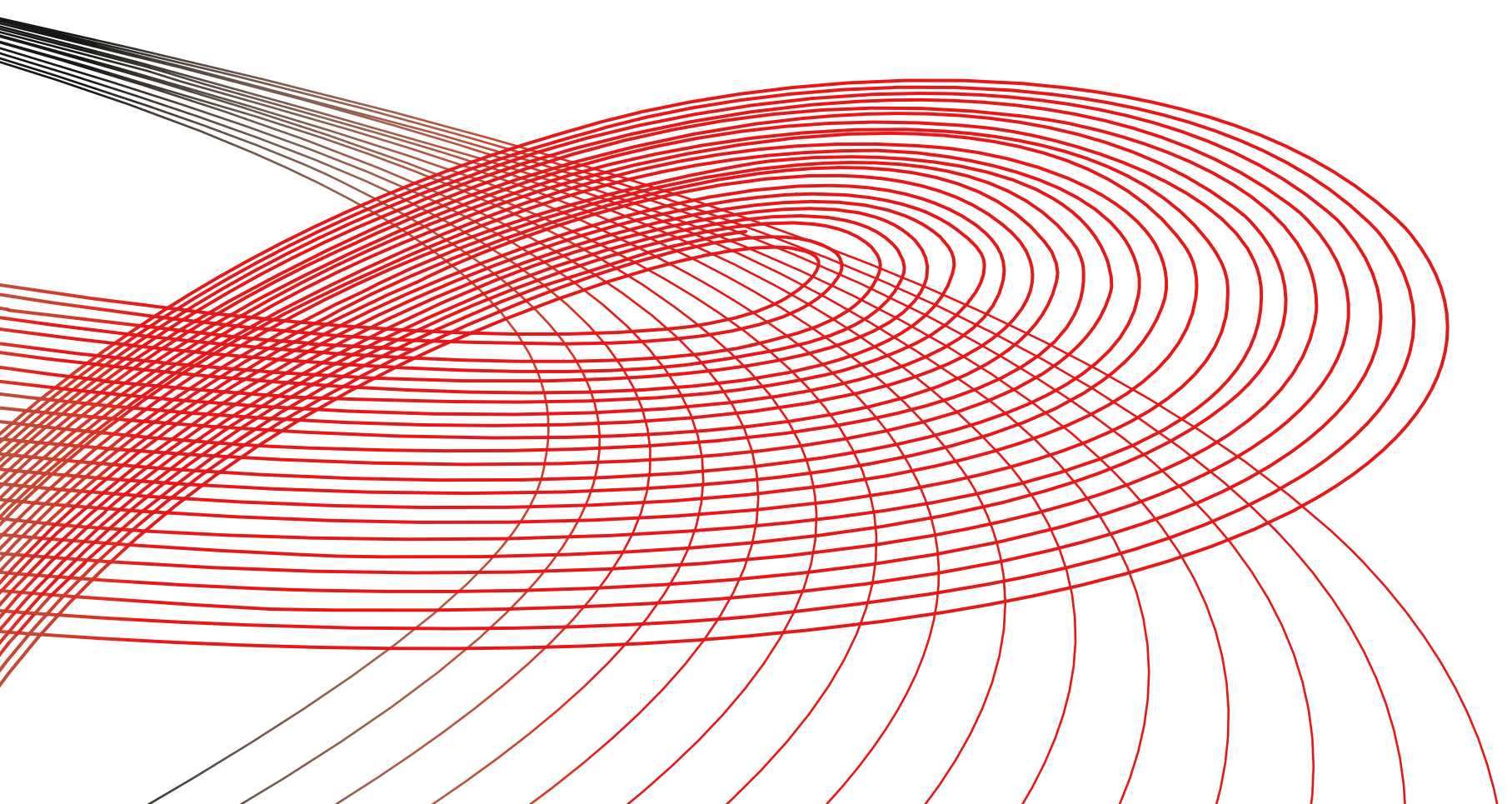

## ■ 2.1 Space on demand: Flexible architecture for changing cities

Paul Clemens Bart, Marvin Bratke

### “Architecture as a presumed future” (Frei Otto)

In the silent film *One Week*, the American comedian Buster Keaton tells the story of the short but eventful life of his home from the perspective of its planner, builder and inhabitant. Forms and functions are reassigned “on the fly” while still under construction. Climatic conditions transpire to cause the house to literally rotate, facades are repurposed into a means of vertical access, and in the end the entire house is run over – ironically just as it is being moved out of the way – by a passing train, blasting it apart into its constituent parts. In the space of just 15 minutes, Keaton shows us the entire life

cycle of a building, with all its ups and downs, joys and frustrations and constant reconfigurations. The house is always in motion in response to changing demands.

Nowadays, architects plan the life cycle of a building over a period of several years or even decades and must make assumptions about technological progress, the future needs of the users, changing socioeconomic trends, new production processes, possible shifts in political and legislative frameworks, climatic changes and the availability of materials. It is a difficult task that requires room for spontaneity in the planning process and flexibility

in subsequent use – and that, at the same time, is vital in order to avoid the building no longer fulfilling the requirements at the time of completion. No building is planned for the present, every building for the future.

### The beginning of an adaptive ecology of construction

Today, the speed of knowledge dissemination and ever more rapid changes in social dynamics are giving rise to a programmatic need for a more flexible approach to building. Architecture that can respond to the needs of autonomous mobility and

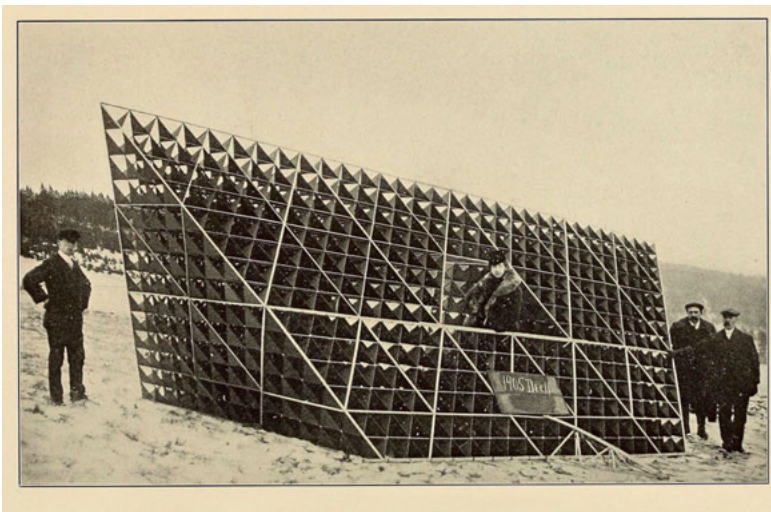

Tetrahedral kite experiments, Alexander Graham Bell, 1903

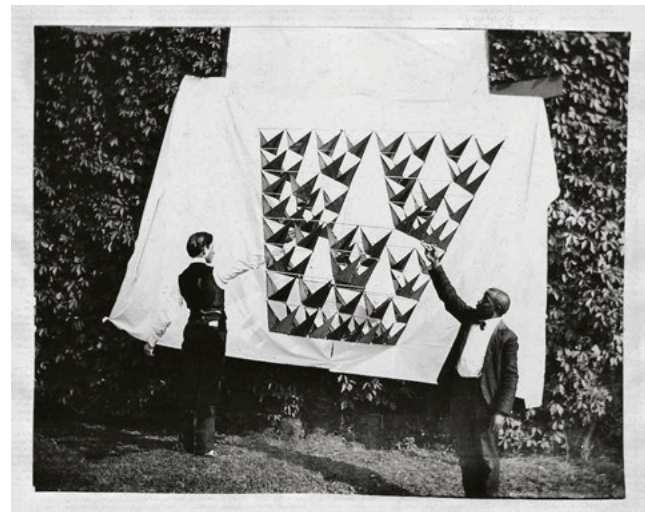



Kinetic building envelope for flexibly programmable space, The Shed, New York City, Diller Scofidio + Renfro, 2018



Mobile robotic systems in Amazon's fully autonomous distribution centres, Massachusetts, Amazon Robotics, 2017

an on-demand society must be able to respond to changes in service trends. Architecture must be agile and flexible – not just in terms of usability and adaptability of the finished building but also in terms of the process by which it comes about and in the management of the planning and construction process.

Existing formalised construction processes and methods are frequently too rigid to respond to changing dynamics in the make-up of modern cities. While the efficiency of sectors such as car and consumer electronics manufacturing has risen dramatically over the past few decades, the productivity of the construction industry has fallen steadily around the world.<sup>1</sup> An obvious solution would be to apply the technologies that have transformed other industries to the field of architecture. Technological innovations, the rise of artificial intelligence, autonomous systems and robotics, coupled with the shift towards autonomous mobility and logistics will play a crucial role in the dynamic and adaptive development of new forms of infrastructure. To respond to these flows, it is essential that we plan tomorrow's architecture as resilient, flexible systems with a circular life cycle.

#### Architecture that moves, reacts and adapts

The desire for more adaptive buildings that are able to accommodate the perpetual flux of life by providing corresponding flexible structures is not a new idea. The drawbridges of medieval castles, for example, were already able to actively change function from being part of the defensive walls to being a

means of passage. Alexander Graham Bell also recognised the need for multifunctional architecture in the early 20th century. As one of the pioneers of modern mass communication, he carried out some of the first experiments on flexible structural systems. His interest lay in the development of mobile principles that could set his loadbearing structures in motion by wind. He later built on the experience gained through his empirical studies of mobile constructions to create complete architectural structures on a larger scale. Drawing on the implications of the kinetics and mobility of his early flying experiments, he implemented them according to new principles: his tetrahedral units were no longer isolated components, but part of a larger network in constant exchange and motion.<sup>2</sup>

After a long phase of reductionism and functionalism – a consequence of the Industrial Revolution – it was primarily the architectural avant-garde of the 1950s and 1960s that celebrated a new era of urban temporality, movement and spontaneity. Buildings, machines and cities began to breathe, to walk, to join and to talk. Yona Friedmann, Konrad Wachsmann, Buckminster Fuller and the Archigram group explored adaptive and mobile systems that would enable their architecture to adapt and move. Their vision was open, flexible systems as space-defining elements with autonomous “plug-ins” as a means of permitting spontaneous reconfiguration and user participation. The sequence of rooms, their position and respective functions could be adapted to meet changing needs, as seen, for example in Cedric Price's best-known work, the Fun Palace (1961),

which served as inspiration for the Centre Pompidou. Archigram's plug-and-play vision of a modular city in Plug-in City (1964) employed similar approaches but enlarged to the urban scale. At that time, the visions of these projects exceeded the boundaries of the possible and so remained predominantly speculative, but today their ambitions are as relevant as ever and this time, the necessary technologies are largely available and already widely used in other sectors.

#### Moving spaces of today – interdisciplinary examples

Current examples of active and adaptable room concepts show the potential of modern technology as an enabler of flexible architecture.

On the West Side of Manhattan, at the heart of the new Hudson Yards development, the largest and probably most ambitious example of adaptive architecture opened in 2019. The Shed by Diller Scofidio + Renfro (at least partially) realises Cedric Price's dream of a flexible cultural and art centre, some 50 years after his original proposal. The eight floors of The Shed house exhibition, educational and event spaces that are flexibly programmable using a kinetic building envelope. While permanent back-of-house functions – offices, building services and storage – are tucked away in the adjacent residential tower, the 35m high building envelope can be freely extended and retracted, transforming the programme of spaces: it can be a multistorey art space or, when fully retracted, a public outdoor plaza.<sup>3</sup> The adaptive architecture allows the build-

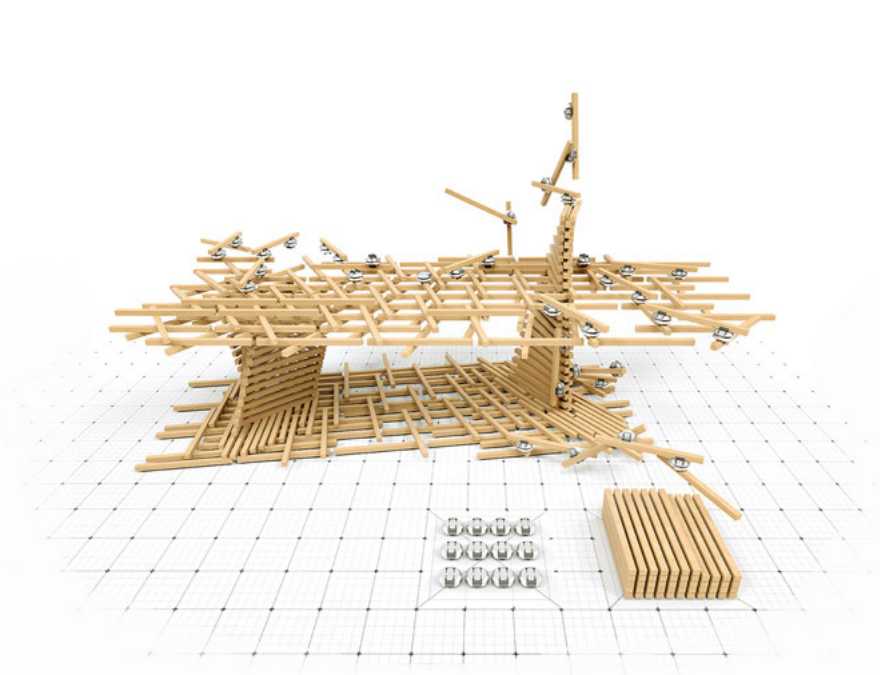

Distributed robotic assembly system for in situ timber construction, ITECH, Samuel Leder, Ramon Weber, 2018

ing to respond to future requirements that may go beyond its actual purpose, even accommodating the changing requirements of the urban space.

The focus of the above example lies on accommodating specific usage scenarios, in this case for an ambitious and representative public building. Large-scale transformable and mobile structures and their accompanying flexible infrastructure are, however, subject to the same limitations as comparable systems in logistics and industrial manufacturing. The production processes for the manufacture of an Airbus A380, for example, take place as an almost choreographed interplay of numerous orchestrated and automated actors that surround the aircraft in changing configurations like a large moving building. The limiting factor is the scalability of the processes: in order to produce an aircraft of this size, the machinery used must be larger than the actual product – or in the case of architecture, of the spatial structure to be constructed. For the serial mass production of a large object such as an aircraft, this may be economically justifiable, but in architecture most such buildings are unique or prototypes, making serial automation a less viable proposition.<sup>4</sup>

For reasons of construction and adaptability, there is a need for greater automation of flexible spaces and infrastructures that are able to respond in real time, in combination with new construction methods already widely used in other industries. The highly complex packaging and logistics processes of online service companies has comparable requirements with regard to scalability and flexibility. Amazon, for example, has developed a counter-

model to the usual machine-controlled assembly line packaging processes, reversing the traditional infrastructure for its distribution centres: instead of the employees going to the shelves, the shelves are transported to the employees. This is done by an intelligent swarm of small, knee-high robots that operate as a choreographed unit, driving beneath the shelves, lifting and placing them where required. As such, the components arrange themselves anew around the person according to the specific requirements of the respective situation.<sup>5</sup>

The opportunity for a similar paradigm shift in architecture – creating flexible space on demand – lies in linking decentralised, mobile units that utilise network effects and can form automated nodes. Using fully autonomous, highly flexible, moving systems on a smaller scale, collective adaptive architectures and temporary structures can be created that respond actively to their environment.

The automobile manufacturer Toyota presented its vision of a “multifunctional moving city” at the CES 2018 in Las Vegas. In a radical reinterpretation of its own corporate philosophy, Toyota declared an end to the prevailing system of urban infrastructure as the transport of goods, people and services, heralding instead a modular series of mobile services in the form of minibuses that inform the cityscape as travelling shop windows, car-sharing opportunities or mobile offices.<sup>6</sup> Infrastructure, consumer electronics and urban architecture merge here to form a hybrid with a collective ambition that goes far beyond the image of “architecture on wheels”.

Similar approaches can also be seen in the rising interest in academic architectural research in modular, small-scale architectural systems characterised by non-finite life cycles: building elements that actively or passively form aggregate structures, and can reassemble and thus form adaptive architectures have the potential to overcome the limitations of the modern manufacturing method of generic industrial 6-axis robot arms.

The “Distributed Timber Construction” research project headed by Professor Achim Menges at the Institute for Computational Design and Construction (University of Stuttgart) employs several small-sized, single-axis robots that have been designed specifically to work with standardised wooden struts as a building material and serve as a locomotive system. Collaborative flexible processes enable the system to be more versatile and responsive in its manufacturing method through the assembly by a decentralised system.<sup>7</sup>

At the Design Research Lab of the Architectural Association in London, Theodore Spyropoulos is researching mobile systems using the principles of modular robotics to create temporary architectures.<sup>8</sup> The origins of the modular, constantly evolving manufacturing system noMad arose in this academic context. noMad aims to extend architecture through the use of a sensory system that successively relocalises the decision-making basis of building processes from element to element instead of following a deterministic superimposed building plan. Anchored in the world of self-structuring polyhedra, noMad is based on Buckminster Fuller’s principles of

synergetics, the study of morphing geometries and the impact of local changes on the behaviour of a global system. From one polyhedron to the next, a single unit can autonomously change its shape and increase its volume many times over through a simple rotational translation by means of an internal motor system. The project operates on three distinct scales of intelligence and autonomy that organise themselves – from a highly mobile, nomadic cluster to large-scale spatial structures. As such, noMad represents a system that can self-regulate and adapt, react to outside influences and demands, and encourages both interaction and communication.<sup>9</sup>

#### From the creator of mass to the curator of processes: The changing role of the architect

The concept of adaptive architecture offers a possible response to rapidly changing infrastructure requirements by enabling urban space to organise itself almost on demand into ever new building formations. Through the recording, analysis and evaluation of big data, self-determined architectural systems could be developed that, when networked, communicate intelligently with each other, as well

as with the user and with the city, and would then be capable of actively responding to the dynamic requirements of the changing urban environment – resulting in a synergy of the city, architecture, (autonomous) mobility and people.

In the context of such scenarios, are we seeing a shift in the role of the architect from that of a creator of mass to that of a designer of processes? Will architects relinquish their control and create systems that facilitate democratic bottom-up processes so that the user can have greater design freedom and the possibility to reconfigure space? The profession of architecture is undergoing a process of transformation towards a new conception in which the architect is a systems designer, a designer of a set of rules for resilient spatial systems. This emancipatory approach makes the user a “prosumer” – that is, both “consumer” and “producer” – a development that is already taking place in many areas, such as in individualised forms of mass production. Architecture is beginning to change, and the user of tomorrow will experience the built environment not as a static mass but as architect-curated space that can be reconfigured on demand.

- 1 McAfee, Andrew; Brynjolfsson, Erik: *Machine Platform Crowd: Harnessing Our Digital Future*, New York, 2017, p. 103.
- 2 Bell, Alexander Graham: “Tetrahedral principle in kite structures”, *National Geographic Magazine*, 14 (6), 1914, p. 219ff.
- 3 Barista, David: Review of “Kinetic Architecture”, *Building Design + Construction*, 20 May 2014, [www.bdcnetwork.com/kinetic-architecture-new-book-explores-innovations-active-facades](http://www.bdcnetwork.com/kinetic-architecture-new-book-explores-innovations-active-facades), accessed on 05/01/2018.
- 4 Tibbits, Skylar (ed.): “Autonomous Assembly: Designing for a New Era of Collective Construction”, *Architectural Design*, 248, Oxford, UK, 2017, p. 12ff.
- 5 McAfee and Brynjolfsson, 2017, p. 103.
- 6 Toyota: *E-Palette*, 2018, [www.cnet.com/videos/toyota-e-palette-is-its-vision-for-a-multifunctional-moving-city/](http://www.cnet.com/videos/toyota-e-palette-is-its-vision-for-a-multifunctional-moving-city/), accessed on 15/02/2018.
- 7 Leder, Samuel; Weber, Ramon: “Distributed Robotic Assembly System for In Situ Timber Construction”, ITECH Master of Science thesis, 2018.
- 8 Spyropoulos, Theodore: *Adaptive Ecologies*, London, 2013, <http://drl.aaschool.ac.uk/>, accessed on 15/02/2018.
- 9 Bart//Bratke, *Project noMad*, 2014, [http://bartbratke.com/portfolio\\_page/nomad-behavioural-fabrication/](http://bartbratke.com/portfolio_page/nomad-behavioural-fabrication/), accessed on 22/01/2018.

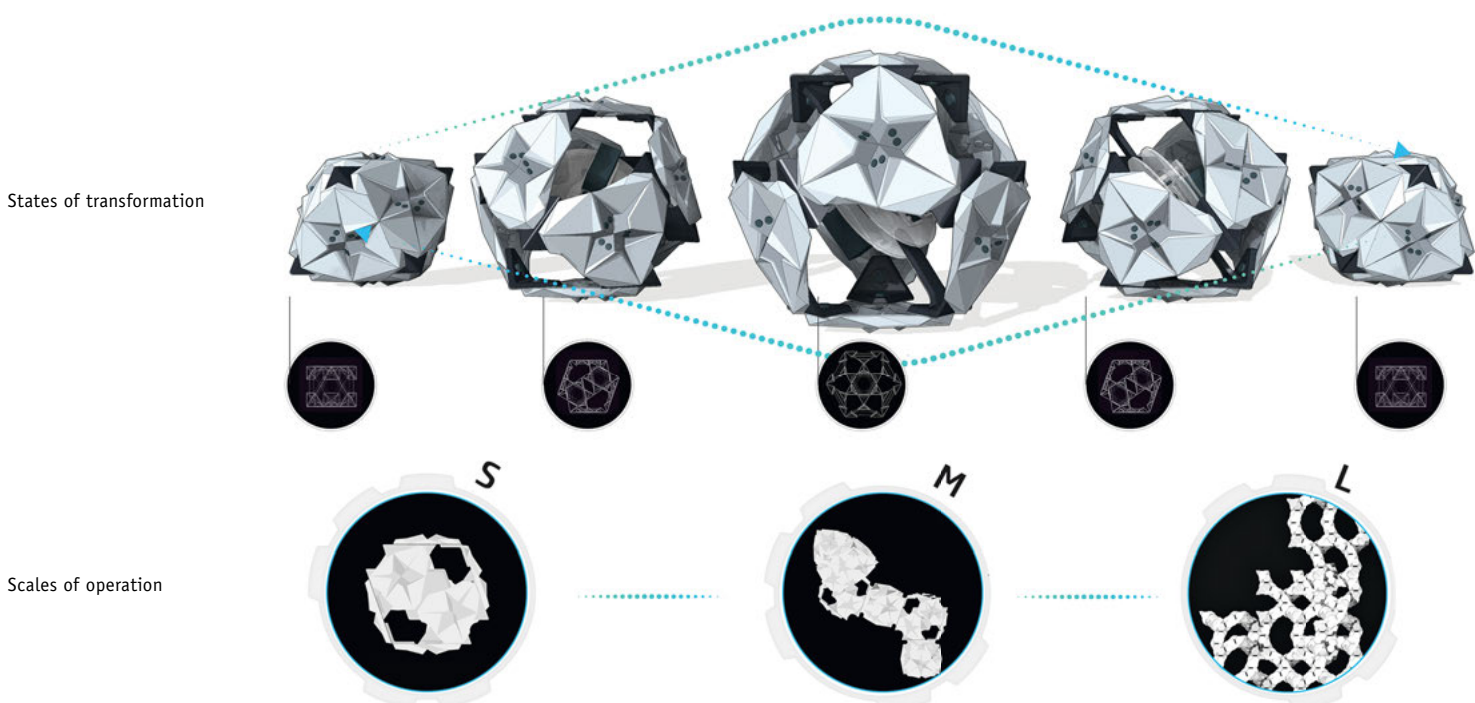

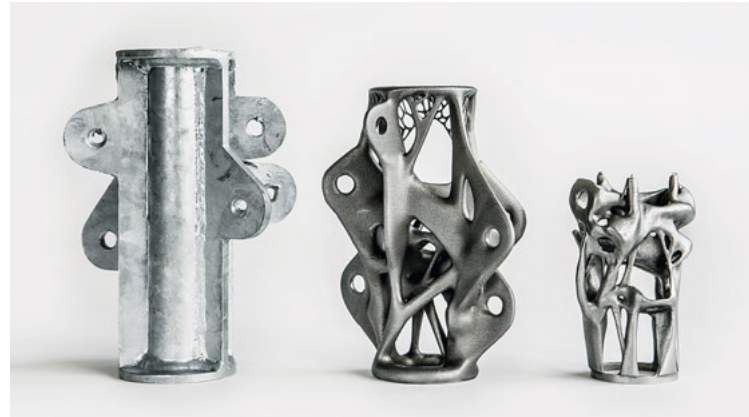

Topologically optimized steel connector

## ■ 2.2 3D printing methods: “Replicate Architecture”

Mirco Becker

3D printing is a collective term for a wide range of different additive manufacturing processes that are used in a variety of applications in medicine, industry and the home. They all involve building up many thin layers of a material in liquid or powder form into a solid object using a computer-controlled process based on a digital model. This technology is beginning to fundamentally change the conditions under which goods are produced as well as the authorship of products. For designers, however, one of the most significant consequences of this process is that the formal complexity of an object no longer impacts on the manufacturing costs; only the amount of material used is relevant. Consequently, design can now follow a biological, resource-saving paradigm, as bionics engineer Julian Vincent states: “In biology, material is expensive but shape is cheap. As of today, the opposite was true in the case of technology.”<sup>1</sup>

### The beginnings of a new production technology

3D printing processes have been used commercially for model and prototype construction since the 1980s but were initially comparatively expensive and limited to small components. It was not until the advent of sintering in the 1990s that the material limitations of the early processes based on liquid resins could be overcome. Since then, robust plastics and metals have been used to manufacture real functioning parts and products. The ability to use 3D printing in actual manufacturing has the potential to bring about a fundamental shift in traditional product logistics. Small batch components

can now be produced economically, as the expensive mould construction required for injection moulding is no longer necessary. Parts that were previously manufactured manually in low-wage regions of the world can now be 3D printed locally and are available more quickly, and in some cases also more cheaply. While 3D printers initially cost the equivalent of a medium-sized car, today’s desktop 3D printers cost no more than a laptop.

### The entry of 3D printing into architecture

Interest in 3D printing for architecture began in the early 2000s with the advent of gypsum inkjet printing processes for architectural model making, a process that is now common in practice and at universities. For a long time, the main barrier to their application for actual architectural components lay in scaling production to the size of real components and buildings.

From the very beginning, 3D printing technology presented the tantalising dream of being able to print entire buildings from scratch. Two protagonists set out to tackle this dream in very different ways. Around 2010, Enrico Dini, an engineer, artist and inventor, built a 3D powder printer measuring several metres across in his workshop that could print cement to produce concrete. Dini’s epic quest to find appropriate technical solutions, financing and suitable structural applications was captured by Marc Webb in the documentary film *The Man Who Prints Houses*.<sup>2</sup> The second person to make this dream come true was Behrokh Khoshnevis together with his research team at the University of Southern

California. Back in 2004, he introduced the technology of Contour Crafting,<sup>3</sup> in which an extruder applies wall-width layers of concrete, each a few centimetres thick. All the necessary building services are integrated into the walls. The extruder is mounted on a portal crane that straddles the entire building to be printed. Since then, Behrokh Khoshnevis has been working with investors and research partners to commercialise the technology through a spin-off company, and to explore wide-ranging applications that go as far as its use for construction on the Moon and on Mars.

As different as the two processes and results may be, they both share the disadvantage that the machine has to be considerably larger than the component to be produced. While Dini’s processes adhere to the logic of prefabrication and on-site assembly, Khoshnevis’ method is based on formwork-free on-site production. In both cases, scaling the machine to the size of the building element or the building would be too short-sighted. While neither of the two methods has yet made it to market, they have given rise to new research initiatives that approach the problem from a design perspective.

### Kinetic components

The formal freedom of 3D printing makes it possible to print movable mechanisms that do not have to be assembled out of individual parts like their traditionally manufactured predecessors but are produced in one piece by the printer with full kinetic functionality. In this way, complete chains, joints or even functional gearbox models can be produced.

A very impressive example from the field of fashion is the Kinematic Dress by the architects Nervous System,<sup>4</sup> which consists of thousands of articulated nylon pieces. The entire dress was fabricated in one piece using Selective Laser Sintering (SLS). However, the use of such 3D-printed mechanisms is suitable for only a few applications due to its inherent process tolerances. Even with advanced processes such as selective laser melting, with which metals can be printed at almost native quality, the layer thickness is 30 µm, and the grain size slightly less, which does not compare with traditional mechanical engineering, where tolerances of less than 5 µm are often required.

One area of use where kinetic components produced using the 3D printer may have an advantage is in compliant mechanisms. A classic example is tweezers, which do not have a mechanical joint but derive their kinetic function solely from the elasticity of the material. That the production of compliant mechanisms using 3D printing can give rise to completely new solutions can be seen, for example, in the work on Digital Mechanical Metamaterials by Patrick Baudisch and others,<sup>5</sup> or the pneumatic soft robots printed in 3D by Skylar Tibbits.<sup>6</sup>

### Design implications

Various teams of scientists are working on 3D printing processes, and their corresponding design implications, in which the extruder is mounted on an intelligent, mobile unit. Probably the most advanced of these is the company MX3D<sup>7</sup>, which is currently working with the designer Joris Laarman to print a stainless steel bridge. The group works with a metal extruder based on MIG welding technology and a mobile unit that can move along the fabricated structure in a manner similar to the form traveller systems used in bridge construction. Such processes eliminate the dependency between machine size and component size, making it conceivable to 3D print very large buildings. The same method also overcomes the second hurdle, the low printing speed, by making it possible to mount several 3D printers on mobile units that work in parallel on the same building.

### Topology optimisation

The design of the Amsterdam MX3D bridge is also notable in that it exploits the freedoms of 3D printing. Using the generative design method of topology optimisation, a digital simulation produces

material-optimised components with partially unforeseen shapes. The process begins with an approximate volume and details of the applied forces, and the computer successively removes material from points of low stress in thousands of optimisation cycles. The final form of the component is therefore “found” rather than predetermined. Drawing parallels from nature, such components have very low material costs, but great formal complexity – a complexity that could not be achieved using traditional formwork.

This is not the only project to demonstrate the validity of Julian Vincent’s prediction of a new economy of form and material. In 2015, for example, Arup developed a 3D-printed steel connection node that fully embraces the paradigm of topology optimisation.<sup>8</sup> For each node of a bar framework or a rope net construction, a form with minimal material input is found based on its respective static load and the required safety level. Benjamin Dillenburger and his team at ETH Zurich are working on a further approach to topology optimisation on an architectural scale using Smart Slab<sup>9</sup> to print slab modules as lost formwork in concrete. Each individual module has a length of 7.4 m, is topologically optimised on the underside and can also include channels for possible prestressing elements. A demonstration of the system was first implemented in 2018 on an area of 78 m<sup>2</sup> of the NEST research building in Dübendorf, Switzerland.

### Agile additive manufacturing

The current state of the art in the use of 3D printing in architecture illustrates how a new technology can stimulate innovations. It also shows that a certain amount of technical and design effort is required before old concepts can be overcome.

Looking forward, there are many aspects in the field of 3D printing that have not yet been sufficiently developed for architectural application. These include the 3D printing of materials with variable density, strength and ductility properties. Such methods could be used to print entire wall constructions as Functionally Graded Materials (FGM) with their respective functional layers in one pass. This field is developing rapidly, in classical materials science and 3D printing as well as in the design disciplines. Large 3D printing farms for the manufacture of products are already a reality today. To meet the different scales and tolerances in architecture, 3D printing can only be successful where a series of

different agile 3D printing robots work together to create a building. The approach used for the MX3D bridge is a step in this direction.

As such, 3D printing technology does not necessarily produce more dynamic architecture, but it does lead to highly agile manufacturing processes, in which a host of autonomous 3D printers may work in unison, distributing, applying and solidifying material on the construction site.

- 1 Vincent, Julian: “Biomimetic Patterns in Architecture”, *Architectural Design*, 79 (6), 2009, pp. 74–81.
- 2 *The Man Who Prints Houses*, Documentary film by Jack Wake-Walker and Marc Webb, Algorithm Films, 2013.
- 3 <https://web.archive.org/web/20100225032636/http://www.usc.edu/uscnews/stories/10009.html>, accessed on 20/03/2018.
- 4 <https://n-e-r-v-o-u-s.com/projects/sets/kinematics-dress/>, accessed on 20/03/2018.
- 5 <https://hpi.de/ baudisch/projects/metamaterial-mechanisms.html>, accessed on 20/03/2018.
- 6 <https://selfassemblylab.mit.edu/liquid-printed-pneumatics/>, accessed on 20/03/2018.
- 7 <http://mx3d.com>, accessed on 20/03/2018.
- 8 Galjaard, Salomé: “Optimizing Structural Building Elements in Metal by using Additive Manufacturing”, in: *Proceedings IASS Annual Symposia, IASS 2015 Amsterdam Symposium, Future Visions – Emerging Technologies: 3D Printing and Robotics*, pp. 1–12.
- 9 <http://dbt.arch.ethz.ch/project/smart-slab/>, accessed on 20/03/2018.

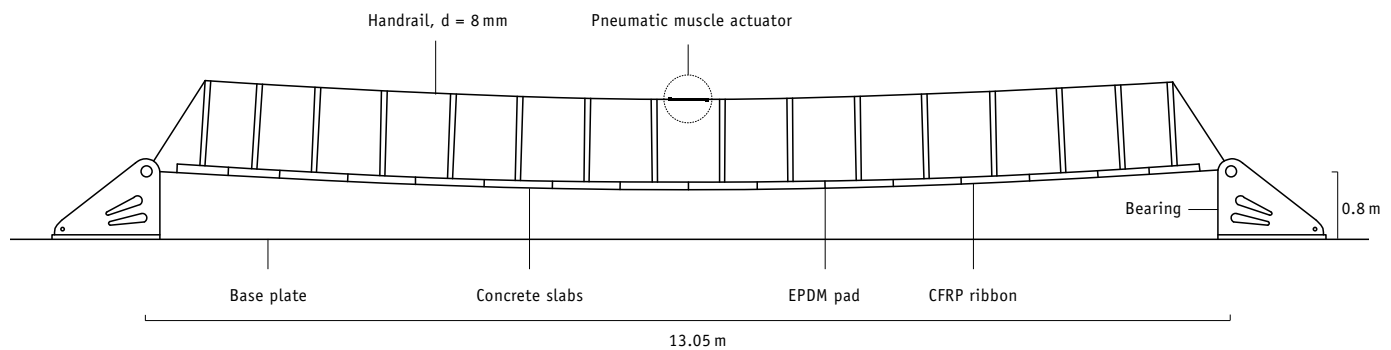

Stress ribbon bridge at TU Berlin with CFRP ribbons and 16 concrete slabs

## ■ 2.3 Active and transformable: Future movement strategies

Arndt Goldack, Mike Schlaich

“Autonomous Bridges” was the title of an article in *Bauingenieur*<sup>1</sup> magazine in 1999 that looked at the future of bridge building. The article discussed self-tensioning carbon cables that communicate with each other and eliminate deformations, noise reduction nets equipped with noise-cancelling loudspeakers and bridge cross sections covered with micro-system foils that present virtual cross sections to counteract the impact of wind and mitigate vortex shedding. Since then we have seen the iPhone, self-driving vehicles and drones. All around us things are getting smarter and more agile – except in bridge building, where little has changed. There are some good reasons for this: bridges are heavy, often wide spanning structures subject to high stresses that are designed for a 100-year service life, much longer than the aforementioned small, lightweight (micro)systems of other industries. New developments have at least led to better detection systems in bridge construction: monitoring systems can now detect and measure phenomena such as deformations, settlements, cracks and accelerations. However, more often than not no one actually knows what to do with this mass of accumulated data.

Of course, there have still been technological advances, and new materials and production methods have given rise to some surprising solutions in bridge construction. Likewise, climate change and the sustainability debate have led to a renewed appreciation of attractive lightweight structures that minimise the use of materials, conserve resources and are therefore sustainable. Traffic will also

change. More bicycle traffic and self-driving vehicles will also lead to more lightweight bridges. Lightweight systems are, however, inherently more “lively”, that is, they oscillate more easily as a result of wind and traffic loads. While many small movements are rarely significant enough to cause bridges to collapse, they do cause material fatigue and impair the experience of using the bridge.

### Moving bridges

Moving bridges are used where crossings or passages have to be temporarily made passable but there is no space for ramps. A wide variety of mechanisms exist for movable bridges: lifting, folding and swinging bridges move enormous girders carrying large masses in just a few minutes. Here, too, new and innovative solutions have arisen that harness technical advances, for example with regard to drive technology and materials.

A new, rather complex bridge with an unusual folding and unfolding mechanism can be seen in the Hörnbrücke in Kiel, a three-span folding bridge for pedestrians with a span of 25.6 m. It is a highly interesting and quite unique construction, which not only opens and closes dramatically, but also clearly shows how the cables and pulleys do their work. In such structures, every gram of the construction counts, since the weight of the bridge deck is not balanced by a counterweight as with a tilt or bascule bridge.

Another, equally novel opening mechanism is that of the Katzenbuckelbrücke (literally, the arched cat’s back bridge), a rising back-anchored suspen-

sion bridge with a span of 73 m that crosses part of Duisburg’s inner harbour. The bridge has a slightly upward curved, flexible bridge girder, which can flex upwards by up to 8 m in the middle section if required. This is done by cables that draw back the masts of the suspension structure. Due to its special construction, the bridge girder can extend sufficiently to allow it to bend upwards.

The lightweight construction of both bridges poses challenges as all unnecessary mass must be avoided. At the same time, such moving bridges must be stiff enough when closed to sustain the load. Excessive vibrations are also undesirable and, paradoxically, mass, i.e. dead load, helps to reduce them.

### Intelligent systems for vibration control

Lightweight construction often leads to person-induced vibrations in pedestrian bridges. New high-performance materials such as carbon make it possible to construct very lightweight bridges with large spans. But vibration problems should not be underestimated, as there is no dead load to counteract these vibrations. A few years ago, a team at the TU Berlin tested a new type of construction. A stress ribbon bridge with a span of 13 m was built with six CFRP carbon ribbons less than 1 mm thick and 50 mm wide in the Peter-Behrens-Halle, the laboratory of the Department of Civil and Structural Engineering. Eight concrete slabs were mounted on these carbon ribbons to serve as the bridge deck, with hard rubber in the 1 cm joints between the concrete slabs, making the bridge very soft and flexible. This bridge has been in use for several years



The stress ribbon bridge at TU Berlin, with active vibration control using computer control and six pneumatic muscle actuators in the handrail



Pneumatic muscle actuator (black) with displacement sensors to measure the degree of deformation

now; students undertake vibration tests as part of their courses, and durability and fatigue strength have been regularly monitored over a longer period of time. At the beginning of the project it was clear that the low mass and the flexibility of the tension ribbons would lead to significant vibrations. Consequently, research into and the development and testing of systems for active vibration control began early on. The decision was taken to use pneumatic actuators to apply pulse-like forces to the handrail posts in a targeted manner and at the right time. Numerous sensors are mounted on the bridge to monitor its movements and relay the information to a computer. Working together with electrical engineers, various control loops were implemented and tested to control the pneumatic actuators. An interesting question in this context is how the control loop and the controller behave when the dynamic properties of the bridge change, for example

when there are more people on the bridge, the tensioning force of the stress ribbons decreases, the bridge heats up or the joints become clogged. Modern systems also have to detect changes in the supporting structures and, using the example of the stress ribbon bridge, take them into account when controlling the pneumatic muscle actuators. This also includes how such control loops in buildings can be self-initiated and self-adjusting. How much engineering work is required to adapt each bridge individually? Can these systems in the future identify the dynamic characteristics of the bridges and make the right decisions and adapt accordingly? Practicable solutions would make it possible to use intelligent systems for vibration control in construction practice.

With active vibration control, as with the stress ribbon bridge, energy must be supplied for vibration damping as well as for the intelligent control sys-

tem. The hardware and wiring, sensors and software become outdated over time and mechanical parts have to be serviced, just as with moving bridges. Overall, however, the tests have shown that such systems – in comparison to conventional solutions with vibration absorbers – are able to further reduce the mass of bridges, making a valuable contribution to lightweight construction.

1 Korvink, J.; Schlaich, M.: "Autonome Brücken – ein Blick in die ferne Zukunft des Brückenbaus", *Bauingenieur*, 75, (1), 2000, pp.29–34.

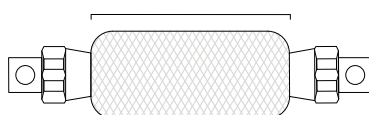

Fully contracted

Pneumatic muscle actuator using compressed air expands in the radial direction and contracts in the longitudinal direction, creating a tension.

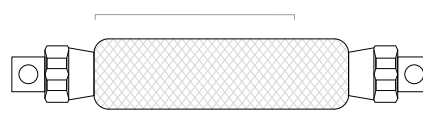

Partially contracted

Pneumatic muscle actuator, partially contracted using compressed air

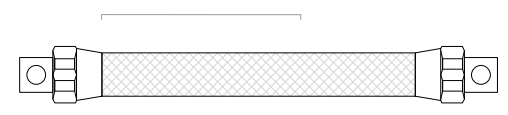

Fully extended

Pneumatic muscle actuator in relaxed state, not filled with compressed air

## ■ 2.4 Shape memory: Movement through shape memory alloys

Jonas Kleuderlein, Sara Kukovec



Close-up of the demonstrator known as “Solar Curtain”

Power-operated components in and on buildings, such as solar shading systems, door drives or ventilation flaps, are typically realised using electric motors and sensor-driven controls. Such systems invariably require corresponding electrical infrastructure for the power supply, the control of the actuators, and integration in the building management system. With the help of shape memory alloys (SMA), however, it is possible to combine actuator and sensor in a single component, obviating the need for further supporting electrical infrastructure, such as a bus system. Intensive research activities in the field of materials science will soon bring configurable functional materials to applications in architecture.

### Principle

Shape memory alloys belong to the group of shape-modifiable materials that can reversibly change their state and properties in response to external influences and thus enable motion cycles. This behaviour is the product of crystallographically reversible martensite-austenite phase transformations. A component can, for example, be deformed from an initial shape by means of an external effect (such as force), and then, through subsequent exposure to heat, return to its original shape as a consequence of restoring forces. The mechanical force component, the switching temperature, and the speed of deformation can be influenced by the type and composition of the alloy.

SMA has a high weight-specific performance: an SMA actuator can move up to a hundred times its own weight. Of all the currently available actuator principles, SMA has the highest energy density. The energy density of NiTi is of the order of  $10\text{J}/\text{cm}^3$ ,<sup>1</sup> and a 2 mm diameter wire with a length of 1 m is able to offset a weight of over 100 kg by 5 cm. Typical SMA alloys include CuZnAl, CuAlNi, FeNiCoTi, FeMnSi and NiTi. NiTi-based alloys are particularly interesting for architectural applications as they are capable of up to one million work cycles without fatigue.

The geometry of SMA actuators can be designed for specific applications: components can be fixed or flexible elements that change shape by rotation and



Overlapping shifting elements employing a shape-memory coil spring actuator to produce a translation movement – shown here in the open state (left) and the closed state. The demonstrator is known as “Chameleon Membrane”.



Petal-like folding parasols that can serve as a solar protection, glare shield or privacy screen are controlled by shape memory actuators employing the translational movement of a coil spring.

	Material deformation	Actuator form	Advantages	Disadvantages
Translation	Contraction	Tension wire, rod, tube	homogeneous load high resilience long service life short work cycles cost effective	short travel connection technology required
	Extension	Pressure rod, tube		
	Thrust	Coil spring	very large opening angle low installation space requirement simple installation	inhomogeneous load special temperature form uneven cooling long cycle times limited lifetime
Rotation	Bending	Torsion spring		
	Bending	Leaf spring	large opening angle simple installation	inhomogeneous load long cycle times limited lifetime problematic back deformation
	Thrust	Twisted wire, rod, tube	large opening angle	inhomogeneous load limited lifetime problematic uniform back deformation long cycle times

Table 1: Advantages and disadvantages of different FGL actuator mechanisms

translation or a combination of the two. Table 1 gives an overview of the typical forms and types of movement of SMA actuators as well as their respective advantages and disadvantages for construction purposes. However, the different forms that SMAs can take on as well as their movement mechanisms are not limited to these and almost any conceivable variant is possible: textile fabrics with SMA threads are possible, as are freeform lamella structures that change their shape depending on temperature.

### General applications of SMAs

SMAs are already successfully being used in numerous fields such as medicine, automotive engineering, electrical engineering, aerospace, data processing, and fastening and connection technologies. For example, surgical tools and implants such as stents and heart valves are made of this functional material. In the construction industry, SMA is currently used in control components for thermostats or smoke and fire control dampers. Initial experiments in using SMAs in structural dynamics are also underway, for example as a damping material against earthquake vibrations and in bridge construction as a prestressing element.

### Architecturally relevant applications of SMAs

Different ways of using SMAs in architecture are currently being explored, with special focus on facade systems. In contrast to conventional solar

control systems, SMA-based approaches do not require motors, sensors or control systems; nor do they require a power supply. Instead, they provide maintenance-free, noise-free and temperature-adaptive protection against the sun, and are moreover decentralised, meaning that they act only where needed. Sensors such as wind monitors, photosensors and time switches – which can be prone to error – are unnecessary.

The use of SMAs in solar protection systems requires a fundamentally new approach. Two model examples include the “Chameleon Membrane”<sup>2</sup> and “Solar Curtain”.<sup>3</sup> Both principles employ SMAs as combined sensor and actuator units and were developed as part of the Smart<sup>3</sup> innovation network. The “Chameleon Membrane” method exploits the colour change that results when SMA-based perforated coloured facade elements warm up under the heat of the sun, causing the elements to shift relative to one another. The degree of transparency and colour changes in response to the ambient temperature and degree of solar irradiation. In the “Solar Curtain”, by contrast, petal-like folding parasols are driven by SMA wires that change their form or length with heat, or when subjected to an electrical current. A return spring causes them to close again. The principle can be used for large glazed surfaces and, depending on the design, can be applied externally or in the space between the inner and outer panes of a multilayer climatic building skin.

These examples represent some of the initial investigations into self-adjusting building components and adaptive elements using shape memory alloys. The full potential of this new technology has yet to be explored and over the course of ongoing research,<sup>4</sup> further design approaches will be developed along with options for developing market-ready systems.

- 1 Krulevitch, P.; Lee, P.; Ramsey, P. B.; Trevino, J. C.; Hamilton, J.; Northrup, M. A.: “Thin Film Shape Memory Alloy Microactuators”, *Journal of Microelectromechanical Systems*, 5 (4), 1996, p. 270.
- 2 The “Chamäleon Membran” was developed prior to Smart<sup>3</sup> as part of a diploma project at Weißensee Academy of Arts in Berlin under the direction of Professor Dr. Zane Berzina (2013) and was turned into a prototypical demonstrator at the Fraunhofer Institute for Machine Tools and Forming Technology IWU.
- 3 “Solar Curtain” was developed as part of a semester project (2014) at Weißensee Academy of Art in Berlin under the direction of Professor Christiane Sauer and likewise realised as a prototype at the Fraunhofer IWU.
- 4 “Adaptex” (like “Chamäleon Membran” and “Solar Curtain”) is an ongoing research project as part of the Smart<sup>3</sup> innovation network, which the authors are working on with other cooperation partners. The details are currently confidential.

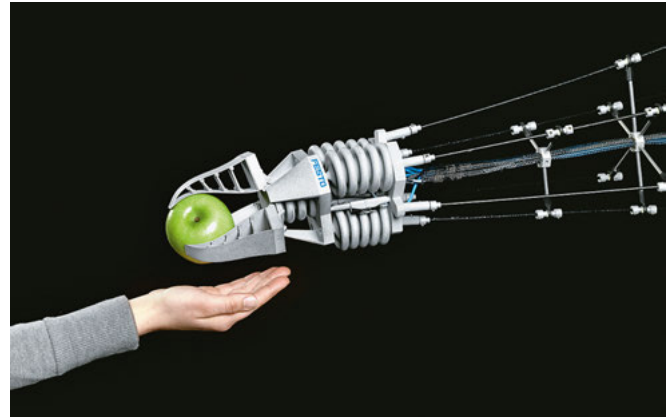

Flexible robots with a responsive soft gripper arm

## ■ 2.5 Soft robotics: The deformation and movement of soft components

Annika Raatz, Mats Wiese

Moving elements in architecture are typically rigid elements that move along predefined paths determined by specific mechanisms. Doors and windows generally open as whole element and rotate about their hinges. Drawers open along linear slide rails, and folding chairs and tables unfold by employing the relative movement of rigid elements to one another.

A developing branch of robotics is the research field of soft robotics. In contrast to the discrete movements described above, soft robotics deals with the continuous deformation and movement of soft components. Soft robots consist of highly elastic materials that enable movement not only at discrete points or along specific paths, but at any point. Their movements are not restricted to the purely rotational and translational movements of rigid components but, due to their continuous deformability, make more organic shapes and movements

possible. Soft robots therefore allow fluid motion sequences in which the shape of an entire element changes.

As in many areas of science, the inspiration for such systems comes from nature. An octopus, for example, has neither a hard supporting shell nor a skeleton but can still open screw caps or move on uneven terrain by skilfully controlling muscles in its soft tentacles. The flexible trunk of an elephant allows it to explore narrow, hard-to-reach areas. It can handle comparatively small objects and carefully manipulate fragile items.

Soft robotics works with these principles, opening up completely new possibilities in the generation of movement. It aims to achieve a high degree of variability in the shapes and geometries of its components. Materials such as polymers or elastomers permit large reversible extensions, which allow the shape of a soft robot to change and adapt as a whole.

Aside from aesthetic aspects, the adaptability of soft materials plays a significant role in the field of soft robotics and presents enormous advantages in direct contact with people or objects. Soft robots are able to absorb and store energy through their elastic deformation. Their softness allows them to mould to objects or to manipulate them without damaging their environment or themselves. For example, soft robots are able to flexibly grip objects of various shapes by enclosing them with their flexible body. With the help of stiffness variable actuators, it is possible to develop chairs that adapt to the shape of the body, or to form entire benches from walls. In its formable state, the structure deforms and adapts, and is then stiffened to retain its shape.

“Jamming” is one method of achieving variable stiffness. A granular material such as sand or plastic spheres is filled into an air-impermeable membrane. The filled membrane is initially soft and deformable,

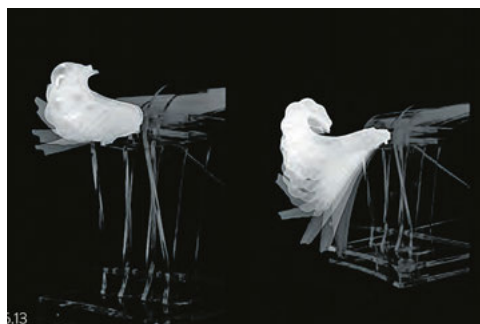
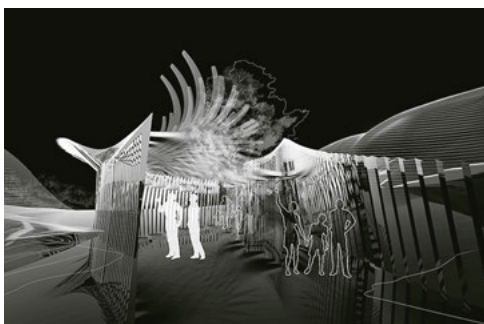

Concept for a pavilion using cast silicon actuators. Using pneumatic actuators, endless patterns and movements can be produced in the pavilion's enclosure.

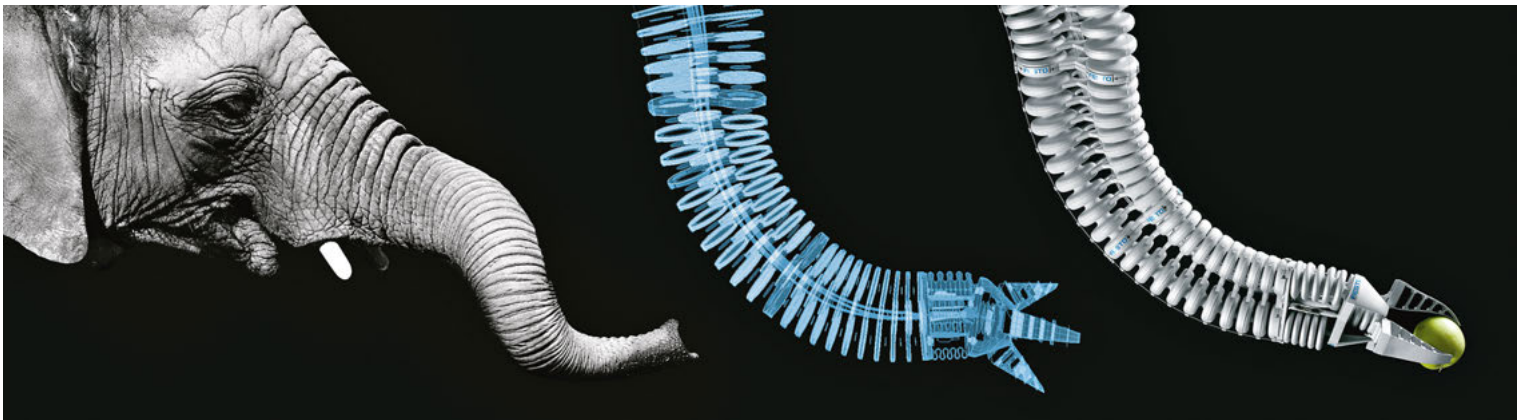

Flexible robots that emulate the flexible behaviour of an elephant's trunk

but when a negative pressure (a vacuum) is generated in the membrane, the spheres and the membrane are pressed together to form a stable state in which the particles can no longer move relative to one another and the structure macroscopically changes to a dimensionally stable state. A similar principle is used for layer jamming in which thin, formable layers are stacked, likewise enclosed in an air-impermeable membrane. Here, too, negative pressure causes the stiffness to change from a formable to a dimensionally stable state.

In the search for ways of producing active motion using soft structures, the field of actuators in soft robotics has explored a number of approaches. Pneumatically driven actuators are a further extensive area of research. Cavities embedded in silicone or elastomer bodies are subjected to pressure, causing them to expand and thus change the shape of the entire actuator. The targeted placement of one or more cavities in a body as well as variably adjustable pressures makes it possible to trigger selective movement of the soft actuator. This approach is a particular focus of research and development in the context of flexible gripper technology. A series of such controllable actuator segments can be used to produce arm-like structures that emulate the flexible behaviour of the elephant's trunk or octopus' arm. Another conceivable application is as flat structures that, when applied to a wall, can change the acoustic properties of a room by pneumatically controlling pressure chambers. Pneumatic actuators are capable of producing large travel ranges with relatively little energy. Pneumatically actuated solar

sails that unfold when pressure is applied and can adjust to match the distribution of incident light are therefore conceivable.

Actuators made of shape memory alloys (SMAs) represent another way of producing motion. The actuation principle is based on the capacity of certain metal alloys to "remember" a certain state and be able to return to it even after large deformations. The metals are deformed in a cold state and subsequent heating causes the material to return to its original state. What makes this form of actuation particularly attractive is the efficiency of the materials used: comparatively large forces can be achieved with lightweight components. Silent operation, long service lives and the possibility of employing the behaviour as a sensor are further desirable properties. Soft robotics is also driven by ongoing research and development in the field of other active materials that react to various environmental influences such as pressure, strain, contact, temperature or light, for example by changing their shape, degree of stiffness, colour or electrical conductivity. The active materials used allow the body of a soft robot to serve both as an actuator and a sensor. For example, temperature-sensitive actuators that react to heat by expanding can, when applied to a window, help block the sun's rays and prevent further heat gain in the interior. The temperature regulating mechanism is adaptive: it requires no explicit control system that activates energy-intensive heating and cooling systems. Soft robotics therefore blurs the boundaries between individual robot components and paves the way towards greater functional inte-

gration: active materials form the body of soft robots and, at the same time, assume the role of sensor; the ability of a soft robot to adapt to a surface and to distribute stresses evenly when gripping an object simplifies what would otherwise require a complex control system.

Soft robotics are most often discussed in the context of applications in industrial handling with variable-form grippers and with respect to human-robot collaborations as well as medical and rehabilitation technology. Soft robots can reduce the risk of injury to surrounding tissue in minimally invasive surgery, where a camera or surgical tool is manoeuvred through a small opening in the body. Their adaptability and sensitive interaction with the environment also make soft robots predestined for exploratory purposes, such as in disaster zones.

Many further applications are conceivable, for example exoskeletons of variable stiffness that assist people in lifting heavy loads, flexible grippers and manipulators that assist people in everyday lives, and robotic pets that look and feel as lifelike as possible. Similarly, adaptive temperature regulation using active materials and individually formable furniture are further examples of how ongoing research in the field of soft robotics has the potential to pave the way for a new generation of robots whose far-reaching applications we are only beginning to imagine.



B

Applications  
and  
functions

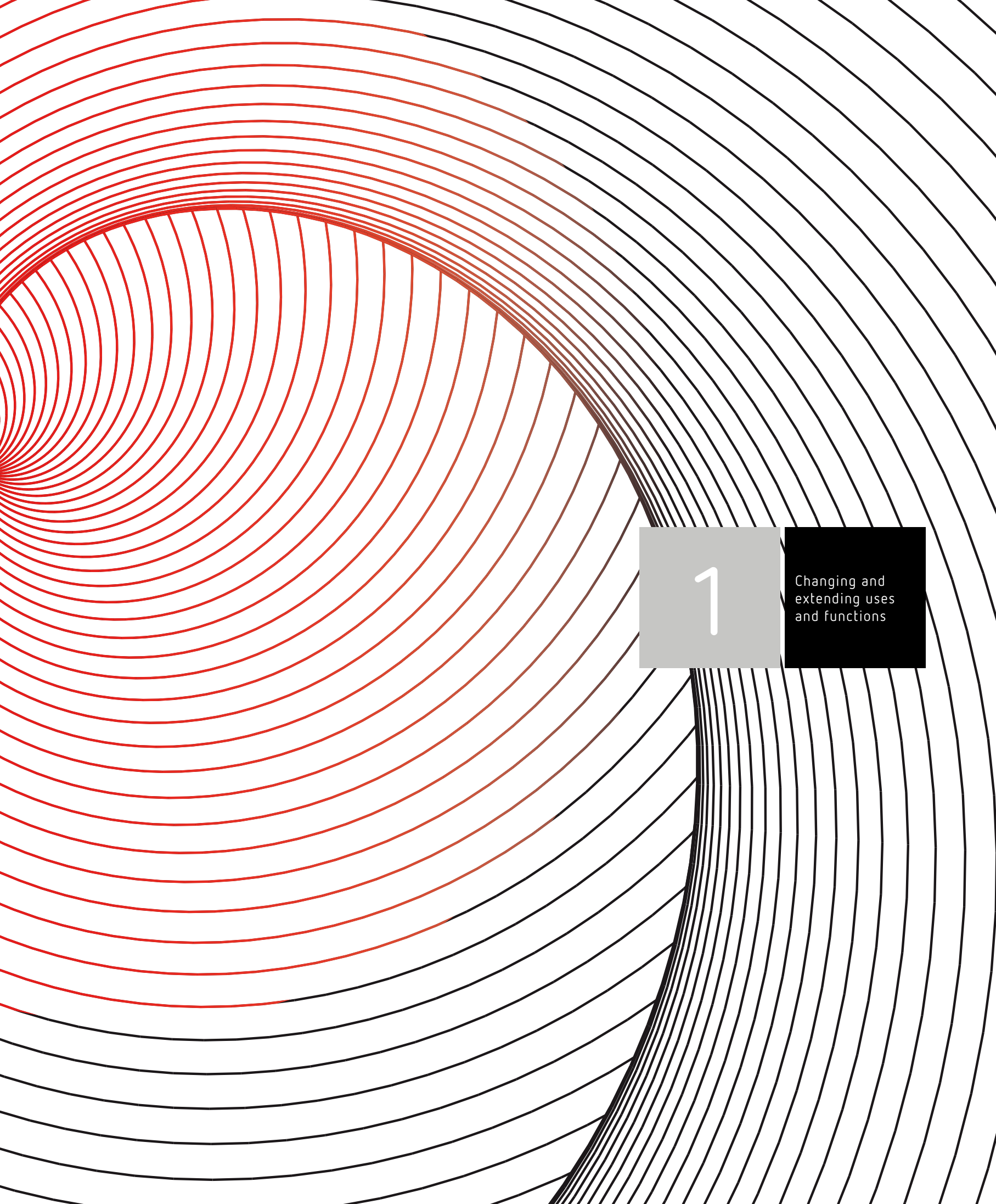

1

Changing and  
extending uses  
and functions



Reduction to the minimum: "Propeller Folding Stool" by Kaare Klint, manufacturer: Carl Hansen

## ■ 1.1 Flexible furniture

Olaf Schroeder

Flexible furniture denotes items of furniture that, by means of their construction, can change state. They are motivated by a desire to minimise material usage and construction as well as to find aesthetic and spatially appropriate solutions for a piece of furniture in its different three-dimensional states. Throughout the history of furniture, people have developed products that incorporate some kind of movable elements in their construction. Whether large containers such as chests or cupboards or small items of furniture such as rolltop desks or chests of drawers, the intention was always the same: to conceal the contents within by means of flaps, shutters, doors or drawers. Even stools from as far back as the Middle Ages or the Bronze Age were made with flexibility in mind, using a simple folding axis to reduce them in size so that they were easier to transport.

This is the theme of flexible furniture: the ability to change between significantly different states, a property that only became technically feasible with the advent of serial furniture production. Alongside the many well-known, inexpensive mechanical principles, specialist suppliers now sell increasingly sophisticated connection systems and extension mechanisms that are enabling new developments in furniture design.

It is no longer hard to satisfy our basic needs in terms of sitting and lying down at a reasonable price. At the same time, this age of competitive and saturated markets is driving designers to find increasingly experimental solutions for furniture – solutions that strive both for aesthetic beauty as well as iconographic clarity in the way they change shape. And here we can come back to our example from the past: the simple construction of the folding stool.

The aspect of "maximum minimisation" in a stool is valuable in many use contexts, for example in camping, military field installations, and events. One of the most beautiful solutions for this category of furniture remains the "Propeller Folding Stool" by Kaare Klint. The leg construction, milled from round solid wood dowels, is cut to emulate the shape of propeller blades so that when the chair is folded, the two crossing legs fit each other perfectly to form a single round rod. The design was created back in 1930, but it could only be serially produced after 1962 when a technically feasible means of milling the solid round dowels was finally found.

The technical principle of the scissor-fold mechanism has inspired so many fascinating applications that one could dedicate an entire book to it. A particularly impressive example that makes a lot out of a little is "Tabula Rasa" (Uwe Fischer, Achim Heine),



Transformation from two to three dimensions: "Rebar" shelves by Jonas Schroeder, manufacturer: Joval



Horizontal expansion by use of the flexural properties of multiplex plywood: "Tojo-V-bed" by Roy Schäfer, manufacturer: Tojo





Geometric play of movable parts: "Lot" table by Wolfgang Hartauer, Manufacturer: TECTA



Deconstructivist overlay of same-size table tops creates shifting perspectives: "Shift" table by Olaf Schroeder

which transforms from a small box-like container into an up to 5 m long extendable table complete with benches. The archetypal appearance of this object-like piece of furniture makes it a milestone in the history of design, especially as its flexible seating capacity introduces an architectural dimension to the room.

A further, highly refined solution of almost ascetic purity with its parallel rows of identical structural bars, is "Rebar" (Jonas Schroeder), a set of foldable shelves. It gracefully folds out to form a lightweight, delicate but stable structure of repeating, parallel, identically sized bars. To fix the vertical and horizontal rows in place, stabilising the structure, the bars are pressed against each other by nuts installed on the rear side of the shelf axes: a long-lasting and versatile solution that can be used in a wide variety of living and room contexts.

Flexibility is also the theme of the "Tojo-V-bed" base (Roy Schäfer). It exploits the flexural properties of multiplex plywood, which allows it to be pulled out horizontally to provide a bed base of variable width for its users. The interconnected V-shaped strips can support two same-sized mattresses, either next to each other or on top of each other.

The "Transformable Table" (Karim Fargeau) literally jumps up from a side table to dining table height. A rope pull mechanism is used to pull the two-part leg constructions beneath the table back and forth between two different rest positions, one low, one high. The clever construction allows one product to fulfil two uses, and to switch between them quickly and easily.

Clearly proportioned geometric shapes form the basis of the "Lot" table (Wolfgang Hartauer). The semicircular segment of the solid oak construction turns and folds elegantly to serve as support for the table, giving it its form. The result is a beautiful play of geometries that is visually appealing when in use and when folded up.

"Stack" (Shay Alkalay) is a vertical tower of drawers. The designer chose a sliding drawer mechanism that allows the drawers to be pushed and pulled in both directions. The result is a striking spatial sculpture that exists somewhere between construction and deconstruction depending on its use. The contrasting colours of the drawers emphasises the "strata" of the stack, an effect that is heightened by the horizontal movement of the individual drawers.

The "Shift" work-life table (Olaf Schroeder) has two equal-sized table tops mounted on the top of table legs. The trick is that the upper of the two can slide along a slot down the centre of the table and can also be rotated about its axis to any angle up to 360°. Its conscious deconstruction not only increases the usable space of the table but also results in a formally variable and striking piece of furniture.

An almost endless series of pleated paper lamellas is the basis of the innovative bench-like seat "Flexible Love" (Craig Chen). Thanks to a special honeycomb construction, it is possible to sit comfortably on a construction of vertical paper. Made entirely of paper, the construction is amazingly stable and, when not in use, can be pushed together into an extremely compact form. A trend-setting combina-

tion of material and construction that has great potential for use.

"Last Minute" (Hauke Murken) is a design that employs folding planes. Slim multiplex panels joined by textile hinges making the construction surprisingly stable. A quickly erected piece of furniture, it changes back from 3D to 2D when not in use and also looks decoratively sculptural standing flat against the wall: a trusty helper for those living in small apartments.

The development of flexible, convertible and transformable furniture looks set to continue, especially in urban areas where living space is becoming increasingly scarce and expensive. Even though their construction may be technically elaborate and therefore more costly, flexible furniture is a perfect vehicle for demonstrating innovation and sustainability in the very fashion-oriented sector of furniture industry.

In the future, we can also expect to see flexible room constellations, such as the prototype of the room installation "Cella" (Stefan Wewerka), which was originally designed back in 1984. "Walden" (Nils Holger Moormann) is an experimental but also highly functional project from 2006 that creates an outdoor room out of a large piece of furniture and offers fresh inspiration for the trend of "cosy houses".

Projecting this trend onwards into the future, we may see a shift away from flexible furniture towards the design of entire spaces as smart microarchitectures that elevate the principles of flexibility and adaptability to a central design objective.

## ■ 1.2 Adaptive by design

Kaja Schelker, Werner Sobek

The term “adaptivity” is often used synonymously with changeability. But adaptivity also means the capacity to actively react to external influences. In building constructions, this can happen at the material level, at the level of building physics and – since the construction of Stuttgart SmartShell, the world’s first adaptive shell structure – at the structural level as well. The concept of adaptivity presented here denotes a new, holistic planning approach for the building sector in which the end product is not the creation of architecture but the development of spatial processes. This approach encompasses the three levels of adaptivity mentioned above as well as previous definitions of the term.

The motivation for adaptive architecture derives from two main aspects:

The ability of supposedly static building elements or buildings to react to external conditions with the aid of self-regulating mechanisms presents a significant opportunity to drastically reduce material usage and thus conserve finite resources. Instead of setting building mass against external influences, for example to improve building physics or to counteract loads, such mechanisms employ momentarily supplied amounts of energy. The initial motivation for adaptive architecture is therefore the desire to reduce construction material usage and conserve finite resources.

The second motivation for adaptive architecture lies in making the users the focus of the planning process. Their needs and wishes should define their immediate environment.

The Institute for Lightweight Structures and Conceptual Design (ILEK) at the University of Stuttgart, headed by Professor Werner Sobek, initiated a series of projects to examine and explore various aspects of adaptivity in the built environment. The text below describes three projects that have since been completed. The fourth is a collaborative research project currently underway that draws on and brings together the findings of all previous projects. The Collaborative Research Centre CRC 1244 “Adaptive Building Skins and Structures for the Built Environment of Tomorrow” was started in 2017 and will culminate in the building of the first adaptive high-rise.

### “Kumo”

One aspect of adaptivity is the spatial reaction of architecture to external influences. Against this backdrop, a group of 13 students at the ILEK Lab under the supervision of Christoph Witte and Stefan Neuhäuser designed and realised an interactive installation for the “Blickfang” design fair in Stuttgart.<sup>1</sup> Inspired by the idea of floating clouds and falling droplets, the installation comprised 30 delicate constructions, each of them a kinematic assembly of straight rods. Suspended vertically from the ceiling, the constellation of 30 constructions formed a notional cloud over the fair’s lounge area. The elements, called “Kumo” (Japanese for “spider” or “cloud”), can open and close by causing the slender bars to expand or contract horizontally. The system was programmed so that their pattern of movements reacts dynamically to the presence of



Spatial installation “Kumo”

people: when a visitor approached the installation, the system responded by causing the respective part of the installation to rise, as if eluding the visitor. Consequently, ever new spatial constellations and atmospheres arose.

To achieve this, the project employed a system of sensors and actuators. Each Kumo could be kinematically activated via a motor-driven winding mechanism that raised or lowered a wire. The sensors were mounted beneath the installations as floor panels and triggered when a visitor stepped on them. A program running in the background controlled both the sensors and the actuators – the motors installed above the Kumo elements – triggering the desired change to the constellation of elements. The program interface also supported the selection of different movement patterns via graphic representations. The attraction of the delicate floating objects lies in their graceful movement and their apparent interaction with visitors, who implicitly became co-creators of a constantly changing pattern of movements.

### “Paul”

The “Paul” project arose as part of a PhD thesis by Markus Holzbach on adaptive textile building envelopes at the ILEK. It explores the limits of changeability of the physical characteristics of building envelopes with a constant geometry.<sup>2,3</sup>

Paul was a cocoon-like structure comprising a base shell made of a glass-carbon hybrid into which stainless steel ribs were inserted as loadbearing frames. The space-enclosing skin of the approxi-

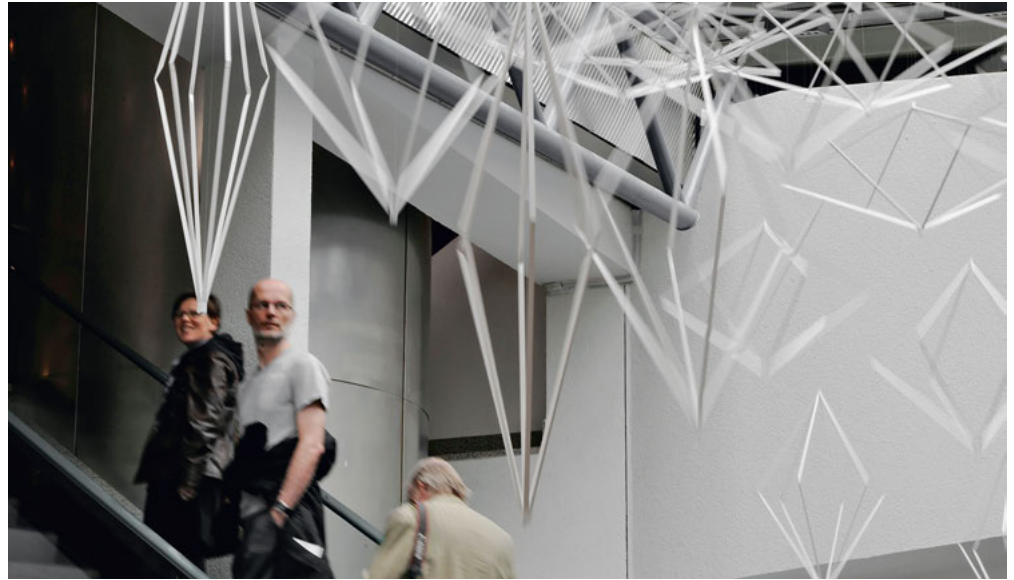

“Kumo” – an interactive installation made by students at the ILEK Lab under the instruction of Christoph Witte and Stefan Neuhäuser for the lounge area of the “Blickfang” design fair. Sensors in the floor panels serve as input for actuators that cause the installation to react dynamically to the presence of the people.

mately 8 m long and 3 m high pavilion took the form of a multilayer textile fabric attached to the steel ribs with Velcro strips. Conceived to act like human skin, the textile comprised various independently acting functional layers. On the outside was a weatherproof skin that could simultaneously emit light: 8 km of integral glass optical fibres and 1,200 points of light enabled it to change colour. The middle layer served as thermal insulation, and comprised a membrane coated with a highly insulating ceramic material. The inner surface consisted of a membrane incorporating phase change materials for storing thermal energy. The insulation and storage layers comprised more than 60,000 cells that could

react to changes in the outside temperature, causing the multilayer system to grow softer at high temperatures. The overall thickness of the pavilion skin was just 14 mm, but its thermal insulation and retention properties corresponded to those of a 150 mm thick wall.

The use of selected smart materials enabled “Paul” to react specifically to changing external climatic and weather conditions. In its aesthetics and building physics – including temperature balance, thermal retention, light transmission and colour – the properties of the cocoon were non-constant. The boundaries between indoors and outdoors was defined by a continuously changing adaptive skin

rather than by static, unchanging, self-contained building elements.

#### Stuttgart SmartShell

The concept of adaptivity can also be applied to loadbearing structures. Adaptive structures react to different load scenarios in order to reduce effects such as deformations or stresses so that the component distributes loads as evenly as possible: the shell structure is equipped with sensors that measure changes in load distribution by evaluating geometric parameters such as extension. If an above-average change in geometry is detected, a controller initiates appropriate countermeasures: a signal



“Paul” – an experimental structure with a multifunctional textile skin on the ILEK site

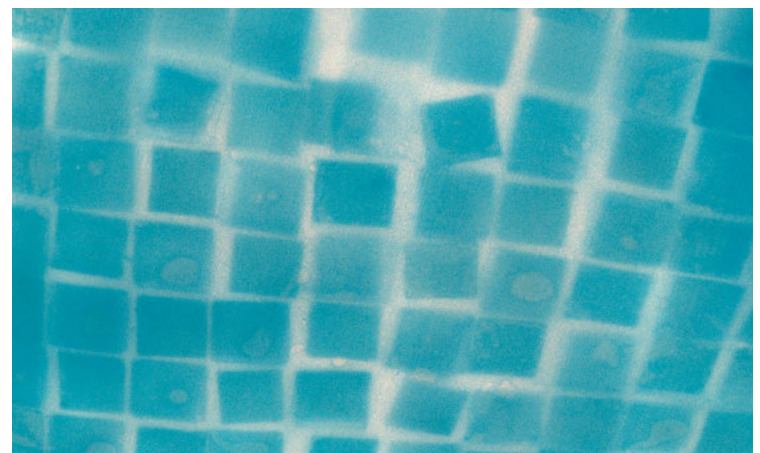

PCM (Phase Change Materials) cells in the structure's skin store thermal energy



The Stuttgart SmartShell uses computer simulations to precisely model the shell's structural dynamics in advance. The control system uses the results of these simulations to optimise the position of the bearings so that stresses within the material of the shell are kept to a minimum.

is sent to an actuator in the structure, which in turn influences its loadbearing behaviour by applying a counter-reaction – resulting in a closed control loop.

The Stuttgart SmartShell represents a significant milestone on the path towards adaptive architecture. It was developed as a prototype by Stefan Neuhäuser as part of his PhD thesis on adaptive structures.<sup>4</sup> Together with Martin Weickgenannt at the Institute for System Dynamics (ISYS) and with support from Bosch Rexroth, the world's first adaptive loadbearing shell structure was erected on the ILEK research platform in 2012. It demonstrates the argument for ultra-lightweight construction as a material-minimising design and construction approach and goes far beyond conventional lightweight construction.<sup>5</sup> The wooden shell with a span of more than 10m is only 4cm thick and would be far too thin to withstand extreme snow or wind loads, were it not for the hydraulically movable supports that can displace three of the four support points on demand to counteract and reduce stresses and deformations, as well as to dampen vibrations. The supports serve as the actuators and can react

within milliseconds to compensate for stress peaks within the construction. The same principle can be used for vibration damping of the shell structure.

#### **Collaborative Research Center 1244 – “Adaptive Building Skins and Structures for the Built Environment of Tomorrow”**

The findings from these and other research projects fed into this collaborative project, which aims to go beyond the idea of moving architecture as purely geometrically changing structures to an all-encompassing concept of adaptivity. In the area of loadbearing structures, adaptivity has the potential to significantly reduce material usage. In the field of building physics, it enables a structure to quickly and easily adapt to different user requirements and changing environmental conditions. For building users, these open up completely new possibilities for intuitively changing their built environment. The objective is to conceive of buildings as open situations in which the user ultimately has more influence than the designer.

The CRC 1244 “Adaptive Building Skins and Structures for the Built Environment of Tomorrow” is an

interdisciplinary project chaired by Professor Werner Sobek in which 14 institutes at the University of Stuttgart, along with other partners, are conducting a series of subprojects on different aspects of adaptive building for the future. The findings and results of the subprojects flow into a common architectural vision: the construction of the world's first adaptive high-rise building, which commenced construction in October 2018 on the campus of the University in Stuttgart-Vaihingen.

The slender tower, with a footprint of around 5 × 5 m, is designed as a lightweight construction to address the demand for a drastic reduction in the consumption of resources for construction. In addition, the differential construction method, in which the components of the individual building elements are connected to each other only at certain points, ensures that all parts of the building can be separated after dismantling and returned to their respective technical or biological material cycles.

The interior of the building can be subdivided as required so that different usage scenarios and interior concepts can be trialled. This makes it possible, for example, to test geometrically variable internal



One of the hydraulic bearings of the Stuttgart SmartShell. The system can respond quickly to forces acting on the structure with a degree of accuracy of 2/100 mm.

walls made of lightweight folding structures developed by the Institute of Aircraft Design. The loadbearing structure of the building is designed as a steel structure and equipped with conventional sensors and actuators. Over the course of the project, these components can be replaced by newly developed actuators and sensors. With the help of the resulting closed control loop, the building can react to different load cases. If, for example, the high-rise starts to oscillate in strong winds, the system can actively counter this. To this end, the Institute for System Dynamics is developing corresponding concepts together with the Institute for Lightweight Structures and Conceptual Design. Each of the ten floors of the building serves as a test module for new types of facades. For example, a switchable pixelated glass facade based on liquid crystal technologies or a breathable shell based on carbon nanotubes as developed by the Institute of Industrial Manufacturing and Management.

#### Adaptive by design

The concept of adaptivity as discussed these projects is understood as a method that will fundamen-

tally change the planning and design of architecture. The boundaries between the built and the natural environment will become increasingly blurred with this concept. The central objective is to increase comfort for the building's users and to minimise the consumption of resources to make the world a better place for future generations.

- 1 Witte, Christoph et al.: "ILEK\_Lab – Experimental Approaches in Architectural Education", in: J. B. Obrębski and Tarczewski, R. (eds.): *Proceedings of IASS Annual Symposia, IASS 2013 Wrocław: "Beyond the Limits of Man"*, pp. 1–8.
- 2 Holzbach, Markus: "Adaptive und konditionierende textile Gebäudehüllen auf Basis hochintegrierter Bauteile: ein interdisziplinäres Funktions- und Formenrepertoire adaptiver Hüllen unter Einsatz von hochisolierenden Keramiken und wärmespeichernden Phasenwechselmaterialien", PhD thesis, University of Stuttgart, 2009.
- 3 Holzbach, Markus; Sobek, Werner: "Paul – adaptive textile Gebäudehüllen", *ARCH+ 37* (172), 2004, pp. 48–49.
- 4 Neuhäuser, Stefan: "Untersuchungen zur Homogenisierung von Spannungsfeldern bei adaptiven Schalentragwerken mittels Auflagerverschiebung", PhD thesis, University of Stuttgart, 2014.
- 5 Sobek, Werner: "Bauen in der Zukunft. Der Schlüssel zum Ultraleichtbau," in: *Deutsches Ingenieurblatt*, 12/2013, pp. 16–20.



A parallel opening window in a partially open state. Mechatronic fittings allow it to act as a noise insulating vent.

### ■ 1.3 A typology of adaptive facades

Winfried Heusler

The moving components of adaptive facades are the means by which a building adapts or extends to meet changing external conditions and user requirements. They quite literally set architecture in motion. Designing adaptive facades requires an understanding of the interplay of function, material, form, context and meaning. These, in turn, require mastery of the requisite technical skills. The final result depends not only on the proper dimensioning of the elements and the choice of a suitable construction method – including appropriate material structure, surface and connection method – but also on the precision of its manufacture and assembly.

Adaptive facades can be classified typologically in terms of their

- methods and mechanisms of movement,
- operating and control modes and user interfaces,
- dimension or scale,
- materials and surfaces.

Kinematics defines different forms of motion<sup>1</sup> that have a fundamental impact on the function and design of the facade. There are six basic degrees of freedom, three for each of the two types of motion, translation and rotation, and components can have three basic states: closed, partially open, and completely open.

In architecture, motion or movement mechanisms typically take the form of hinges and actuators, with or without gearing. The mechanism has a decisive effect on the quality of use, and particularly

on the degree of maintenance. They also influence the speed of the movement and the change between different states. Components can be operated manually, mechanically or mechatronically, or be motor-driven, either individually or in groups. The type of control can be manual, controlled or regulated and can act on a single axis, a room, a storey or an entire facade. The user interface – be it a handle, switch, touchscreen, speech, gesture or facial recognition – similarly plays a central role in the ease of operation.

The size of moving components is a factor of the mass that needs to be moved (large masses are difficult to accelerate and stop), while their scale can affect proportions and therefore the design. The materials and surfaces of the components as well as their specific treatment or processing and joining influence not only their degree of transparency or translucency, but also their air, moisture and smoke permeability and their transmission of heat and solar radiation.

Adaptive facades can be classified typologically into the categories mobile, dynamic and agile facades.

#### **Mobile facades**

Mobile facades do not only have technical functions, but also serve to order and articulate. Most commonly, they are used as a means of delimiting areas. Moving facade elements can connect or divide interiors from the outside world, changing both the architectural form and the enclosed space.

Facades and facade elements can be made mobile using different forms and mechanisms of movement.

Very often, mobile elements employ sliding mechanisms, and occasionally also turning, folding or swivelling mechanisms. Individual mobile facade sections are often relatively large and are therefore commonly motor-driven. Their movement is controlled either centrally by an operator or individually by the user, and increasingly frequently with the help of modern, user-friendly touchscreens instead of simple switches.

#### **Dynamic facades**

In Central European temperate climates, dynamic facades are particularly advantageous, as their components can be adapted to changing weather conditions. In principle, they can consist of the same materials and have the same movement forms and mechanisms as mobile facades, but their dimensions and masses are often smaller in comparison. The moving sections are usually motor-driven and are controlled in response to changing external conditions. Whether users are able to override the automated control according to their own needs impacts not only on user satisfaction, but also on energy consumption (for heating, cooling or ventilation, depending on the type of moving element) and the external appearance of the building. Similarly, the arrangement of moving elements (within or on the inner or outer face of the facade) impacts on the function and design of the facade as well as on cleaning and maintenance costs, and in turn on service life and durability, not just in terms of long-term functionality.

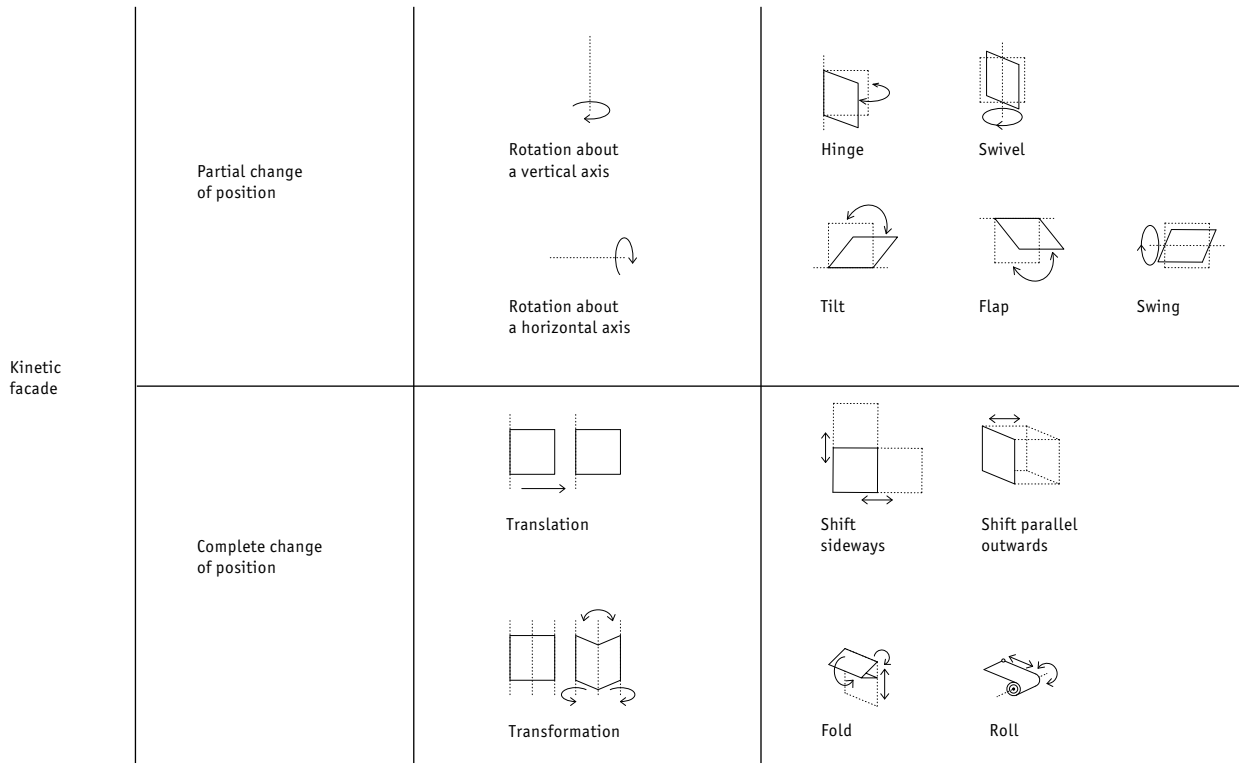

Movement typologies of kinetic facades

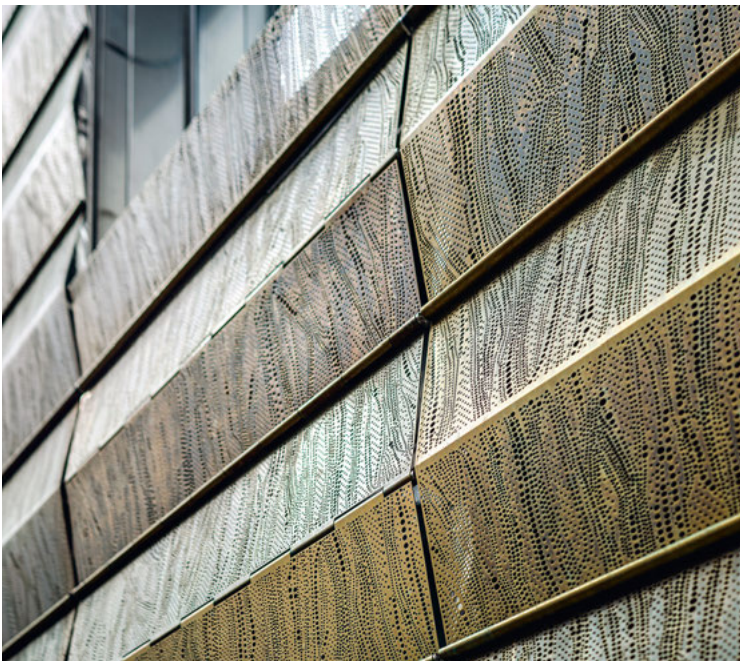

Dynamic facade: moving elements change its function and appearance.

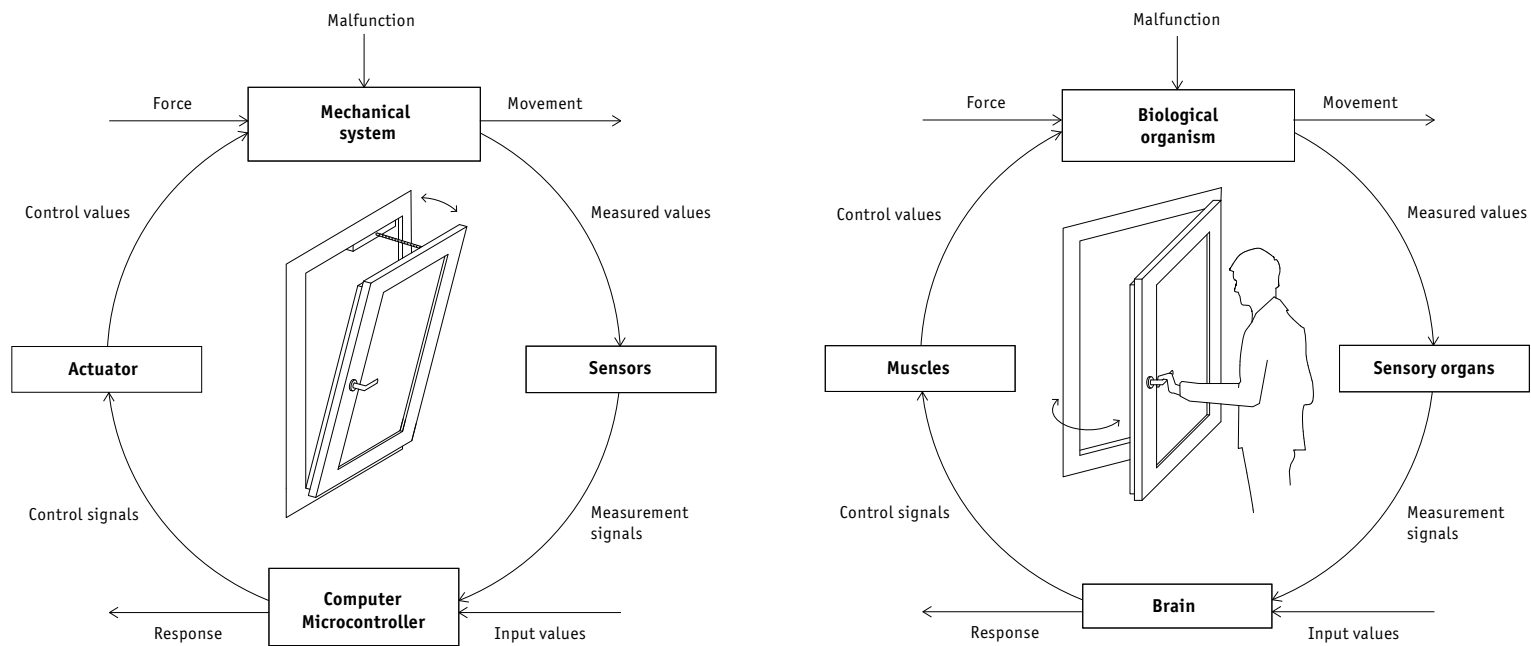

Principles of technical and biological systems

To optimise its operation, the building needs to know its current state and that of the surroundings. An intelligent control system then decides which actions to initiate based on the ambient contextual information. Elements and components can be made to respond to discontinuous, changing internal and external conditions that are predictable or calculable (e.g. the position of the sun). Advanced systems can also take into account unpredictable control criteria such as changing weather constellations or irregular usage patterns such as the presence of people after hours. Two alternative approaches exist, which can also be used in combination:

- The building is equipped with sensors for external as well as internal conditions and has an access control system on a personal and possibly room level.
- The control system is connected via the internet to regional weather forecasts and to the GPS of the smartphones of a building's possible users.

As a rule, the subsystems of the building envelope and the building services are interconnected and operate in unison.

The individual components of dynamic facades are usually mechanically coupled per axis, room, storey or facade, and actuated by groups of electric drive systems, making different corresponding functional and aesthetic effects possible. The way in which movable building elements are interconnected therefore also influences the aesthetic expression and emblematic or symbolic appearance of the architecture.

#### Agile facades

Agile facades are complex systems that react independently to changing external conditions and individual user requirements. They are made up of numerous elements that interact dynamically with each other. Their components can employ the same movement forms and mechanisms as dynamic facades, but their actuation and control can make use of the new possibilities provided by digital transformation. The same applies to user interfaces. It is now cheaper than ever to embed digital components – microchips, sensors or cameras – in objects that were previously digitally “unaware”. As such, physical products and objects can be augmented with digital capabilities.

Agile facades are also increasingly difficult to classify unequivocally as analogue (purely physical) or digital (purely virtual) systems. These hybrid configurations can be described as digital-physicals or “digicals”.<sup>2</sup> They can incorporate microcontrollers, communication systems, identifiers, sensors and actuators, which can communicate with each other via short-range radio technology such as NFC, RFID and WLAN, or via mobile telephone networks. New functions can also be added subsequently with an update of the corresponding app. As such, they are not only configurable but also potentially individualisable at a later date.

Agile systems employ the principle of subsymbolic or neuronal artificial intelligence<sup>3</sup> and are composed of several semi-autonomous subsystems or individual elements – including, for example, “digicals” – which communicate with each other and interact as a whole. Through the parallel preprocessing of external signals, they can react in real time. Agile systems are capable of:

- Perception by means of sensors (of both temporally varying environmental conditions as well as user needs and behaviour),



Mobile facades can change the architectural form and spatial enclosure.

- Processing using microcontrollers (which analyse collected data and decide whether they should adapt their own behaviour),
- Reaction by means of actuators (putting into effect the decision made through direct physical interaction with the environment).

They also have the ability to act flexibly, proactively, adaptively, anticipatively and on their own initiative. The individual components learn independently, not only from their own perception and experience, but also from each other.

We now know that living organisms and many technical systems function according to the same principles in the way they interact with the environment. The more information a system collects about the behaviour of the building and about the responses and behaviour of representative user groups or even

individual users under defined conditions, the greater their practical benefit for humans. These findings can also be used for the future development of new products and their control systems.

Since the individual components of agile systems can also be controlled and operated independently, the decision as to which components move synchronously and in what constellations, e.g. per axis, room, storey or facade, can depend on the specific situation and functional or design reasons. This opens up entirely new design possibilities. Control systems may define certain patterns of actuation (e.g. according to a choreography) or respond more spontaneously to external or internal influences. The dynamics of incident light during the day and artificial lighting at night can be used as additional design elements including variable angles of incidence, light intensity and light colours.

- 1 Westenberger, D.: Untersuchungen zu Vertikalschiebefenstern als Komponenten im Bereich von Fassadenöffnungen, PhD thesis, TU München, 2005.
- 2 Münchner Kreis (ed.): *Neue Produkte in der digitalen Welt – Forschungsprojekt des Münchner Kreis*, Munich, 2016.
- 3 Jeschke, S.: *Kybernetik und die Intelligenz verteilter Systeme*, IKT.NRW series “NRW auf dem Weg zum digitalen Industrieland”, Wuppertal, 2014.

## ■ 1.4 Retractable roofs

Knut Stockhusen, Knut Göppert



BC Place Stadium in Vancouver with its integral LED-illuminated facade

The increasing need for event venues such as courtyards, arenas or stadiums to flexibly accommodate diverse uses poses new challenges in the design of their roofs. In addition, roofs need to cater for different climatic and acoustic conditions that can vary significantly from day to day and season to season. Modern open stadiums sometimes need to be transformed into a fully covered arena within just a few minutes. The growing demand for such adaptive and multifunctional roof structures has given rise to some new and pioneering developments.

Innovative engineering solutions are the product of the ongoing exploration and development of design principles that continue to push the boundaries of the possible. In the process, a combination of in-

genious design concepts, high-performance materials and modern drive and control technology lead to compelling design solutions that are feasible for everyday use.

### Mobile and foldable roofs

The need for retractable or mobile roofs or roof sections increases the number of unknowns one has to deal with from the beginning of the design process. In particular, the intermediary states of the roof during transformation are short-lived but critical situations. All the different intermediary states need to be analysed in detail, resulting in a series of different load scenarios for both the fixed and moving parts of the structure. The loaded area varies, and equilibrium states change, requiring

wind flows and loads to be recalculated for all relevant building parts in all the different states. Each of these building configurations must then also be considered in the building approval procedures.

The categorisation into mobile (solid) and foldable (textile) roofs illustrates the different planning requirements: while mobile roofs are stable in themselves, they involve the movement of large masses and surface areas. Foldable roofs with textile skins, on the other hand, are considerably lighter and more compact, but for the short time during transformation, they are not prestressed and only regain their mechanical or pneumatic prestressed state once in their final position. These intermediate states must be closely examined in order to define the boundary conditions to ensure safe use. Using



Interior of the stadium with the central suspended video screen block



Opening process of the inner roof membrane



Twin-layer, pneumatically inflated pillows

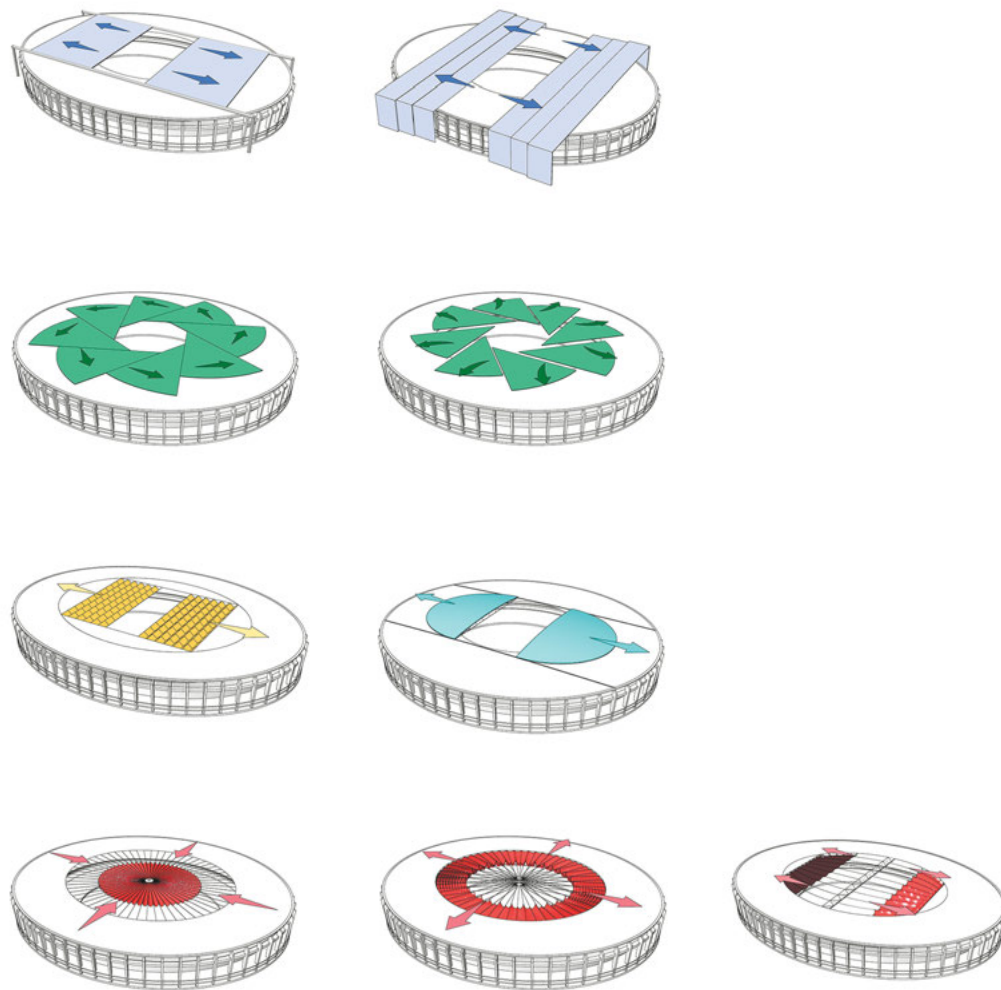

Variants of retractable roofs

modern sensor technology, it is possible to monitor these limit states during operation and, if necessary, exert corresponding mitigating influences via an automatic control system.

For both roof types, the design process must consider global and local deformations and rotations as well as the reciprocal influence of the loadbearing primary structures in the overall model. This is the only way to ensure the compatibility of all parts at all times. In addition, the weight of the movable or foldable structure plays an important role in both roof types: the lighter the structure, the simpler the drive technology can be, in turn reducing costs and simplifying maintenance.

#### Driving concepts

In movable roofs, the areas that are openable are covered by large, solid constructions. There are virtually no limits to the creativity of the designer when it comes to design. The movable roof parts

slide along rails and are driven mechanically or hydraulically. Where space is limited, multipart covering elements can be developed that function, for example, by overlapping or twisting.

An alternative approach is to vertically hoist the entire openable section of the roof using cables to create a ventilation opening while still ensuring the desired shading.

Foldable sections for openable roofs can be incorporated harmoniously into the architectural design of a roof and require considerably less space. Here, transverse beams between the structural members travel mechanically along lateral rails with folded membranes or lightweight membrane-covered frames between them.

The most lightweight roof constructions, compared to the other typologies, are those that replace the primary steel structure of the roof with a cable construction. Here, the membrane is fastened to the cables by means of mechanically driven sliding

carriages that cause the membrane to open and close.

The membrane is not the only element that can be made to move; the suspension cables can also be moved. In such constructions, the secondary and primary structures are parked out of sight of the spectators when the roof is not required, so that nothing can be seen of it or its supporting structure. All that remains is a completely free opening.

#### Special foldable roofs

The first foldable membrane roof of this size was realised for the Commerzbank Arena in Frankfurt for the 2006 FIFA World Cup. This pilot project served as the basis for two subsequent further developments for the stadiums in Bucharest and Warsaw.

The foldable membrane inner roof of the National Stadium in Warsaw is the first cable-supported membrane roof that can be used all year round. The roof's membrane can sustain snow loads of up to

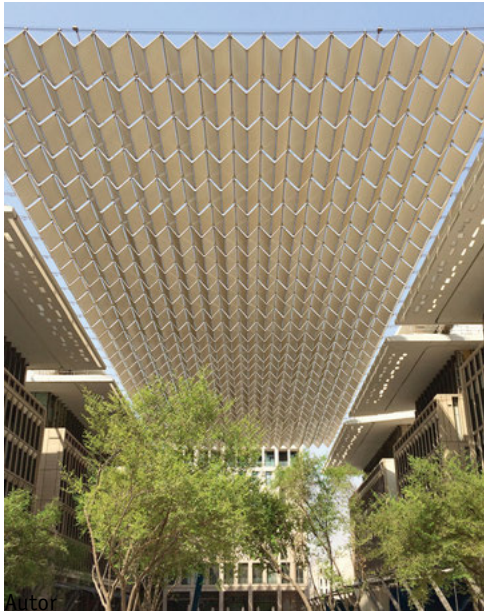

The closed underside of the roof over Barahat Al Nouq Square, Doha, Qatar



Substructure of the retractable roof

100 kg/m<sup>2</sup>. Planned for the UEFA European Championship in 2012, the stadium can be transformed into a multifunctional arena with over 70,000 seats in a matter of minutes. In autumn 2013, it hosted the United Nations Climate Change Conference. For this purpose, the playing field was converted into a congress centre with various conference rooms. The existing VIP boxes served as smaller meeting rooms during the event.

The foldable PVC-coated polyester membrane is stowed in the central membrane garage when the roof is open. When the inner roof needs to be closed, the garage first drops a few metres. The inner roof membrane can then travel outwards along the 60 radial spoke cables on sliding carriages pulled by cable winches towards the fixed outer roof. Once the hydraulic stressing cylinders have engaged, the roof is prestressed by parallel belts.

Even more extreme weather conditions had to be taken into account for the design of the roof of the BC Place Stadium in Vancouver, Canada, as the snow loads potentially acting on the foldable roof are even greater. The roof skin therefore consists of pneumatically inflatable cushions, which are highly translucent due to the use of a high-quality PTFE-coated fabric. After radial, mechanical unfolding, the cushions are inflated, creating an internal pressure that is set automatically between 500 and

2,000 mbar depending on the snow load. This means that events can be held independently of changing climatic conditions. The level of year-round utilisation of the multifunctional arena has since improved significantly, and the roof is in use almost every week. In addition to improving comfort for visitors, the new roof also provides better sound insulation for local residents.

The usability of urban squares can also be enhanced with movable structures. In the Heart of Doha project in Qatar, a retractable roof allows the central square of a new district to remain an attractive and pleasant environment even during the hot midday period. The interplay of the pleated shading roof with the fully automated, intelligent, natural cooling and ventilation technology makes it possible to use the square all year round. Individually controllable membrane-clad panels, each measuring 3 × 1.5 m, unfold concertina-style along parallel cables. A sophisticated drive technology makes it possible to independently adjust the individual rows to open to different degrees and folding angles, allowing light incidence and shading to be variably controlled depending on the position of the sun.

#### Building in existing fabric

Existing structures, such as buildings from antiquity, can be protected, modernised and made more usa-

ble by retrofitting a movable or foldable roof. Examples include the arenas in Nîmes and Zaragoza, which were equipped with foldable roofs many years ago.

A further milestone in the development of modern “masters of transformation” is the design for the roof of the Arena di Verona, one of the largest and best-preserved amphitheatres from Roman times. Built in 30 CE under Emperor Tiberius, the Arena is now a world cultural heritage site and a major tourism destination in the region. For more than 100 years it has been an impressive and atmospheric open-air venue for operas and concerts. In this case, the task was to design a retractable and demountable canopy that would enable the arena to be used regardless of the weather and, at the same time, to protect the building fabric against environmental impacts. The design principle is based on the functionality of the spoke wheel. The specific innovation of this unique concept lies in the complete retractability of the membrane roof and also of the entire supporting cable construction. The carrier cables are arranged in a fan shape in the oval compression ring. The resulting asymmetry produces a differential load on the compression ring, resulting in an increased construction depth of the ring where the anchorage points of the cable converge. At the same time, this wider section serves as the membrane

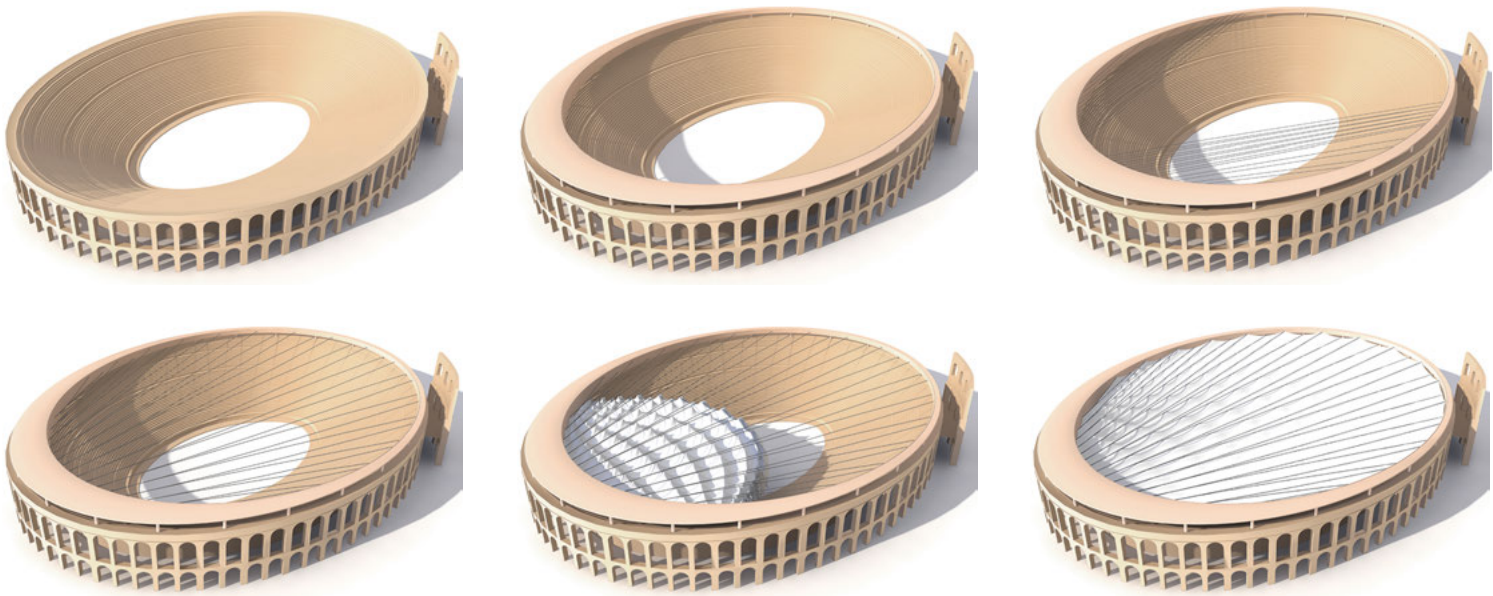

Closing sequence of the proposed roof over the Arena di Verona

garage and also harbours the withdrawn suspension cables once the membrane has been fully retracted, leaving the view into the night sky completely unobstructed. Both from above as well as from beneath, the closed roof looks like a protective clam shell that covers the historical arena. From outside the arena, the new roof is barely visible; only from further away is the compression ring visible as a slender ring hovering above the arena.

Through the innovative and intelligent interplay of the centrally closing fan-shaped arrangement of supporting cables and the membrane covering, the entire arena – including the crowning historical wall – is protected from rain and inclement weather as required: the ends of the carrier cables travel around the compression ring on each side, meeting at the middle on the far side of the arena like a theatre curtain closing. The membrane skin is then stretched along the supporting carrier cables to form an elliptical covering. The radial cables roll up on cable reels behind the membrane garage so that the membrane remains permanently threaded on the cables even when stowed in the garage.

The cable heads on the inner face of the compression ring are hinge-jointed to special cable carriages which, activated by individually and precisely synchronised electric winches, travel along the C-profile main rail. The suspension cables likewise unroll at a

controlled and synchronised speed. Each cable carriage runs securely guided along the rail with heavy-duty rollers on all sides to its specific position while the cables unwind to the required length. Once in position, hydraulic cylinders lock the carriages in place and the cable winches in the garage prestress the cables to a precisely predefined tension.

The membrane is then driven out of the garage along the tensioned suspension cables. The folded membrane opens like a fan, pulled into position by self-driving tensioning carriages travelling along the cables.

The prestressing forces for both the cables and membrane is determined precisely such that the cables are always under tension and never sag at any moment during opening. This prevents the membrane from getting stuck with a large area only partially extended. The roof opening process is the same in reverse until the cables are completely retracted into the stowage garage.

#### Perspective

Active and adaptable buildings and lightweight structures point the way forward, also with respect to the economical use of resources in building. Given the ongoing growth of large cities around the world, flexible approaches to using public spaces and venues will be increasingly in demand. Modern

operator concepts are also increasingly moving towards variable structures that allow events of different sizes to take place in quick succession and in all weather conditions, whether strong sunlight or heavy snowfall. New concepts enrich the range of future possibilities and, together with new materials, will gradually become part of our living environment and everyday lives.

## ■ 1.5 Adaptable houses

Richard Murphy

After my third year as a student at Newcastle University I had a stroke of luck to get a year's job working on the small Caribbean island of Saint Lucia. Most of my time was spent designing modestly sized individual houses. It took about a month for my brain to adjust to the idea that, because the temperature never dipped below 22 °C, walls were not about enclosure against the elements. Rather it was possible to omit an entire external wall and thereby transform an otherwise internal space into what

effectively became a permanently inhabited deep veranda. Provided the issue of security could be solved, the modernist dream of a complete fusion of inside and outside space could easily be achieved. (We would even omit the roof over the shower in a bathroom; more rain, more shower!)

Returning to the UK and changing university to Edinburgh I was physically instantly aware of the contrasting temperatures; between Scotland and the Caribbean but also between a Scottish summer and

winter, seasons which varied little in the Caribbean. I nevertheless yearned for the possibility that somehow that sense of the total freedom of spatial ambiguity between inside and outside could be recreated, even at this northerly latitude. But not only do temperatures here vary between winter and summer, it was the contrasting hours of summer and winter daylight which impressed me most in my first year back. In the Caribbean sundown lasted half an hour. In Scotland, on 21 December, night



Murphy House, Edinburgh. The main space with its many levels serves as the living room. All openings can be closed using shutters in winter.



Main elevation seen from Hart Street. The building acts as a “bookend” covering the blank gable end of an adjacent row of buildings from 1820 (right).

had arrived by half past three in the afternoon; on the evening of 21 June I had been reading a book in daylight at close to midnight. And the further north one goes, the more spectacular is the variation in light. In the Shetland Islands, midsummer is called “the simmer dim” and it never really goes dark all through the night.

We all change our clothes depending on the season and yet our buildings remain remarkably similar. In the 18th and 19th centuries, internal timber shutters physically closed off the night but in the UK in later Victorian times, as coal became comparatively cheap, even shutters were considered superfluous. This is a conversation not just about responding to varying temperatures; it is more an idea about the psychology of winter and summer. Aldo Van Eyck, the great Dutch architect, writer and teacher said once that “a house is both a bird’s nest and a cave”,

that is, an extrovert place in the summer open to landscape but a retreat in the winter; or, more immediately, in day and night-time modes. The modern movement has performed well for summertime architecture. Gradually, all the *poché* on the plan has been whittled down to be replaced with glass until finally, with Mies van der Rohe’s Farnsworth House and even more demonstrably Philip Johnston’s Glass House, nothing is left at all. And yet wintertime has its own psychological needs, which I would contend are ill suited by these buildings. Charles Rennie Mackintosh understood the psychological requirement of winter or night-time. Witness the white cave for the marriage bed at Hill House, illuminated when the shutters are closed only by lilac-coloured tiny rays of sunlight. At a much larger scale, the library in the Glasgow School of Art presents a permanent and I believe deliberately

gloomy interior, an autumnal light suited to study where even in the height of summer light fights to get in through the projecting bay windows and deep reveals of the thick stone walls.

For the past 25 years my practice has been experimenting with the idea that domestic architecture can have three modes of skin: summertime where sliding windows and doors appear to disappear (often using the Frank Lloyd Wright trick of the disappearing corner window), wintertime where insulated shutters to windows and skylights cocoon the interior, and an in-between “normal” mode of glazing. Starting with house extensions in the Edinburgh area, our first fully shuttered house was in Aberdeenshire, followed by various mews houses in Edinburgh and culminating in my own house in the centre of the historic New Town. Unconstrained by a client, I have had here the opportunity of devel-

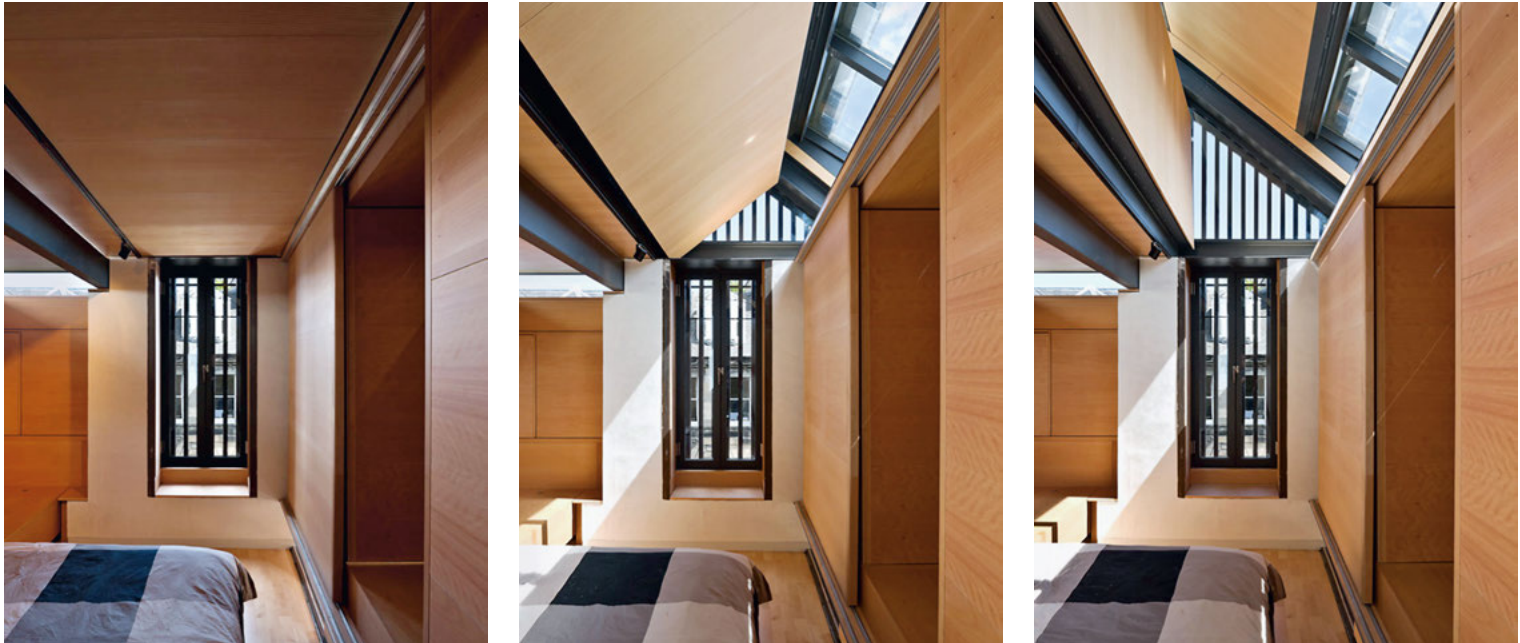

As in the living room, the main bedroom has a shutter, this time ceiling-mounted, that can be closed in winter and opened in summer.

opening a whole variety of moving parts within one small but tightly packed house. All windows are shuttered with hinged, pivoting or sliding shutters. Two very large roof lights to the main living area and the master bedroom are both closed at night by electronically operated hinged shutters which move from the vertical to the horizontal. In this way the volume of the space is compressed and most importantly transformed in a psychological way; a bird's nest becomes a cave at the touch of a button! And needless to say, these shutters also have a major effect on the thermal insulation of the interior.

In the 1960s and 1970s, much play was made in the UK of an architectural slogan "long life, loose fit, low energy." Adopted by the "high tech" architects Foster, Rogers, Grimshaw, etc. we can see such iconic buildings as Centre Pompidou in Paris, Lloyd's in London, or Foster's London Stansted airport, to name but a few, as representative of that philosophy. History has not been kind to any of them, however.

Rogers' early obsession with placing services on the exterior to free up the interior and ostensibly to allow for the replacement of short-life mechanical plant whilst maintaining the occupation of the building seems now to be wholly counterproductive. Not only do Centre Pompidou and Lloyd's have extraordinary maintenance budgets but the exposed

total overall surface area of the building, while requiring servicing elements to do a job they were never designed to do, mitigate against the low energy objective. The idea of "total flexibility" might seem a noble sentiment to allow for the unpredictable to happen and therefore prolong the life of a building, but not only are so many of the most basic attributes of architecture suppressed for this one objective, also the management of the building is allowed to effectively redesign it. The former can be seen at the Pompidou: there is no memorable interior space, no selection of views from the interior or vice versa, no hierarchy of space, no manipulation of natural light, no sense of entrance and other than the famous escalator, no sense of promenade. The latter phenomenon can be seen by the commercially ruthless interior of a shopping mall that has been imposed on Stansted's open and flexible volume. Paradoxically, Foster's "open" building has been completely subverted to one which is totally closed; a horrific interior that departing passengers must now suffer. Interestingly, Rogers seems to have learnt that lesson with his Madrid Barajas Airport; a remarkably inflexible building!

To me "flexibility" is almost always an architectural disaster; by contrast, "transformability" is a totally different prospect. One of my favourite projects, Chareau and Bijvoet's Maison de Verre in Paris is a

house and doctor's surgery full of sliding screens, pivoting cupboards, even a retractable staircase, etc. which change, combine or divide spaces, but in predictable ways. Similarly, the upstairs plan of Rietveld's Schröder House is an astonishing idea that a daytime family living space can change to nighttime bedrooms through sliding and pivoting elements. That to me is far more interesting than vague ideas of open-endedness, and has been a source of inspiration for many of our interiors – making buildings that enjoy the fourth dimension of time. Indeed, an essential part of a tour of my own house is to show visitors all the many moving parts. In the summer they want to be transported into winter and vice versa, allowing the house to be a responsive organism equally responding to both external elements and inner psychological needs.



An apparently translucent corner of the bedroom made of stone panels: Rietveld's Schröder House meets Scarpa's Olivetti Showroom in Venice!



B

Applications  
and  
functions



2

Conserving  
and generating  
energy

## ■ 2.1 Smart skins

Brian Cody

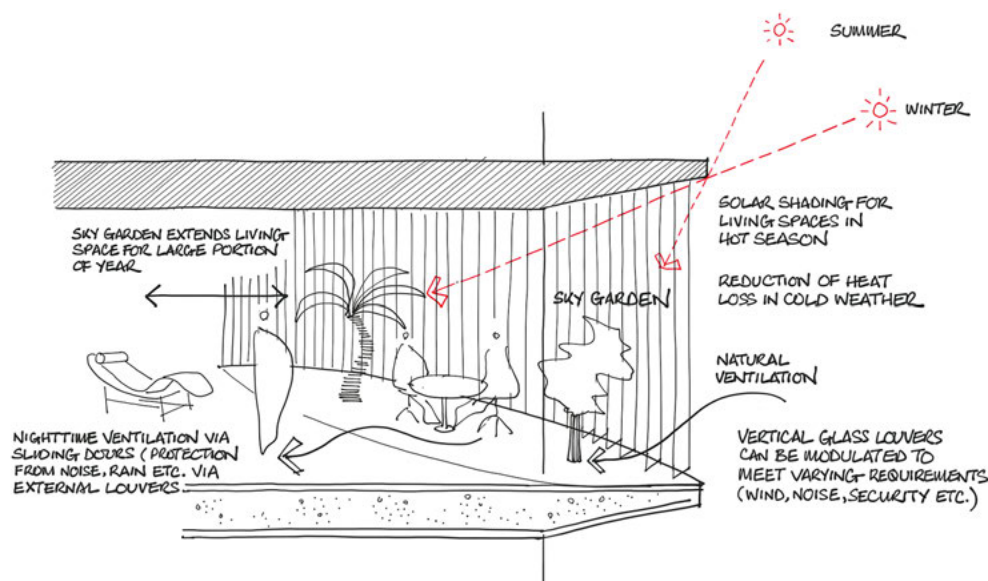

Skygarden concept for residential tower in Manhattan, Coop Himmelb(l)au architects

A building facade can act as an adaptable filter between the external and internal environments. The physical properties of facades are, however, at the present time unable to adapt to changing conditions in a significant manner. This applies to the ever-changing external conditions such as climate, noise, air quality and light, as well as to the fluctuating demands and needs of building occupants on the internal side of the facade interface. The specific properties of facades in terms of thermal conductivity, solar heat gain transmission, light transmittance, porosity, etc. are static and remain essentially constant with time, although the requirements for an energy-efficient building skin differ significantly under the widely varying climatic conditions and patterns of use at different times of the day and year. The building skin, as interface between the internal and external environments, has an important role to play in the task of achieving desirable internal conditions. The external conditions vary during the course of the day and more so over the course of a year. Internal conditions considered comfortable for human occupation are more or less constant and vary little throughout the world. However, due to the fact that we occupy and use buildings in a dynamic way, coming and going, changing our activity, etc., the internal side of the interface also includes a highly dynamic component. We would expect, therefore, that for a building skin to be effective in energy design terms, the skin as interface should reflect the dynamic worlds on both sides of the interface. If we look around us, however, whether in Manhattan, Moscow, Berlin or Hong

Kong, we see static surfaces of stone, concrete and glass – building envelopes which remain unresponsive to and unchanging, totally oblivious of whether it is  $-20^{\circ}\text{C}$  and dark or  $35^{\circ}\text{C}$  and sunny outside: with the result that the buildings HVAC systems have to work hard to achieve comfort within.

Building skins should be dynamic. They should not only provide protection against the elements but act as a filter, selecting, mediating and modulating between inside and outside. The fact that they do not, for the most part, has of course to do with cost and complexity but also perhaps with certain architectural dreams we are still chasing. The famous unbuilt glass skyscrapers Mies van der Rohe designed in the 1920s come to mind. Sometimes, buildings which were not built are more important than those which were. If we look at contemporary architecture, the static unchanging envelopes make this apparent. On the other hand, if we look back to buildings from past centuries, we see building envelopes which evolved to include many elements that react to sun, light, temperature and the need for privacy.

In a research project at the Institute of Buildings and Energy, Graz University of Technology, we are studying the possibility of reinterpreting this type of adaptability using the technology available today. This research forms the scientific basis for the development of entirely novel facade constructions. The emerging “Smart Skins” are facades that maximise energy performance by varying their properties to adapt to changing external and internal conditions. An adaptable and variable building skin

can react and adapt to both internal and external conditions, effectively creating “Space on Demand.” One simple example is movable, highly insulated elements, which in a closed position form an airtight connection with the primary building facade, allowing the transparent portion of the building skin to vary down to 0%, provided that the spaces behind are not in use or their use, at a given time does not require daylight.

Energy and climate concepts developed for recent projects by the consulting firm Energy Design Cody show some interpretations of how smart skins can be used to achieve high energy performance. For a residential tower structure on 101 Murray Street, Manhattan, New York City designed by Coop Himmelb(l)au architects, we developed an adaptive facade which enables an innovative system of natural ventilation, while providing a new type of winter garden space. The outer layer can be modulated to react to different conditions relating to wind, noise, security, etc. Sliding doors in the inner facade layer, positioned roughly 2 m back from the outer layer, allow the living space to be extended for a large portion of the year. The “Sky Garden” acts as a buffer zone in cold weather, reducing heat loss and providing solar shading for the living spaces in the hot season. Natural ventilation and nighttime cooling in summer can be controlled by modulated opening of the two facade layers.

The void contained in this facade system offers inhabitable space and, at the same time, incorporates strategies to provide energy-efficient ventilation and maximise energy performance. It fulfils the

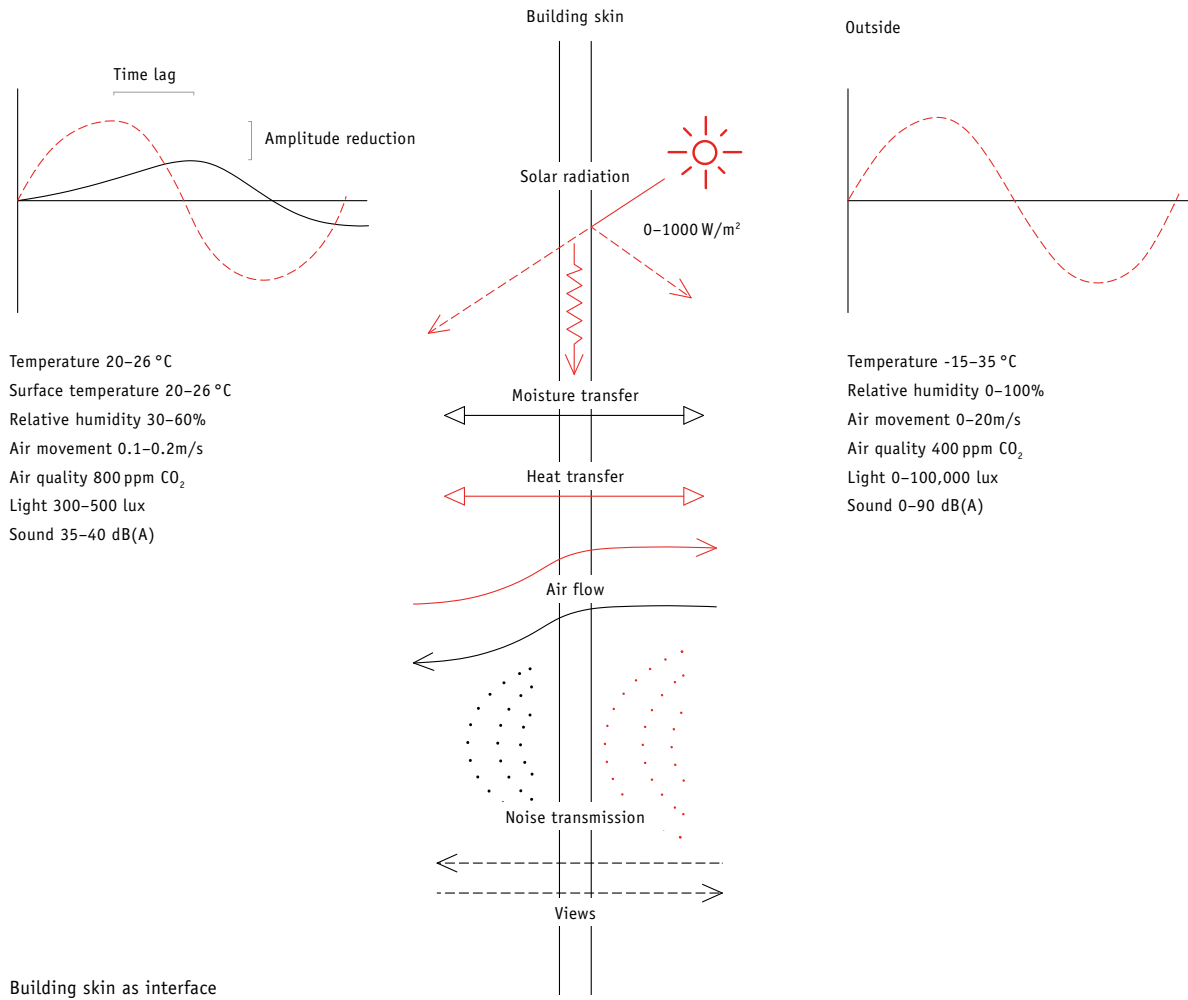

Building skin as interface

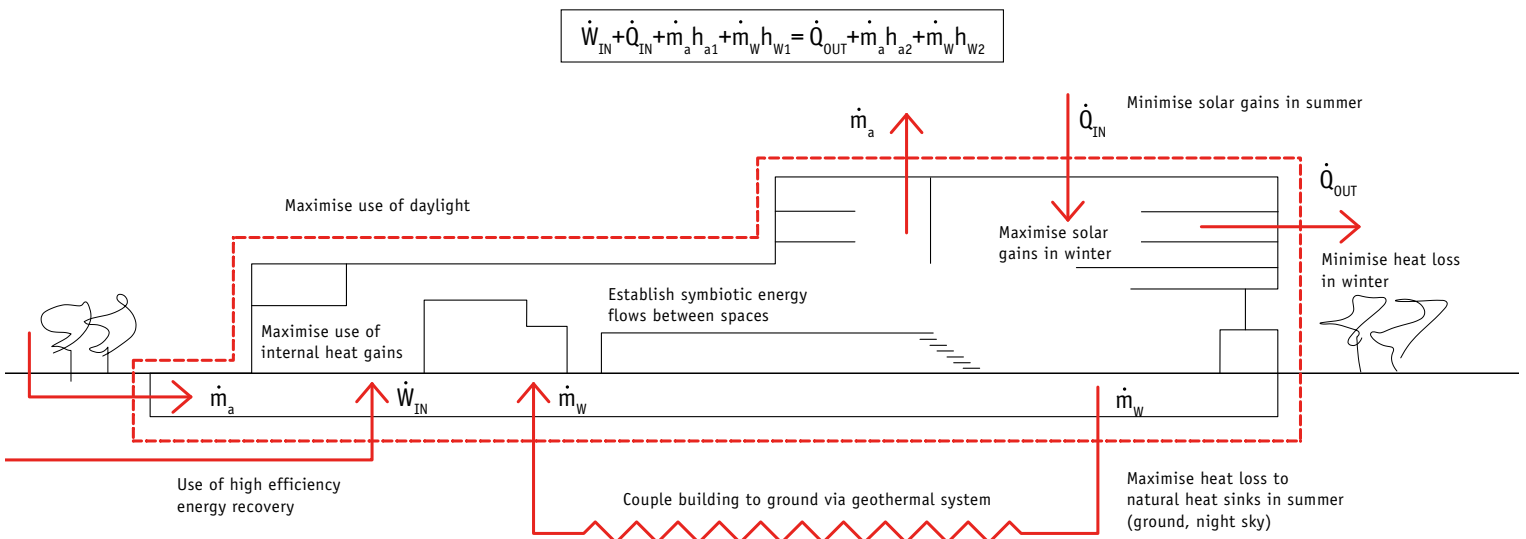

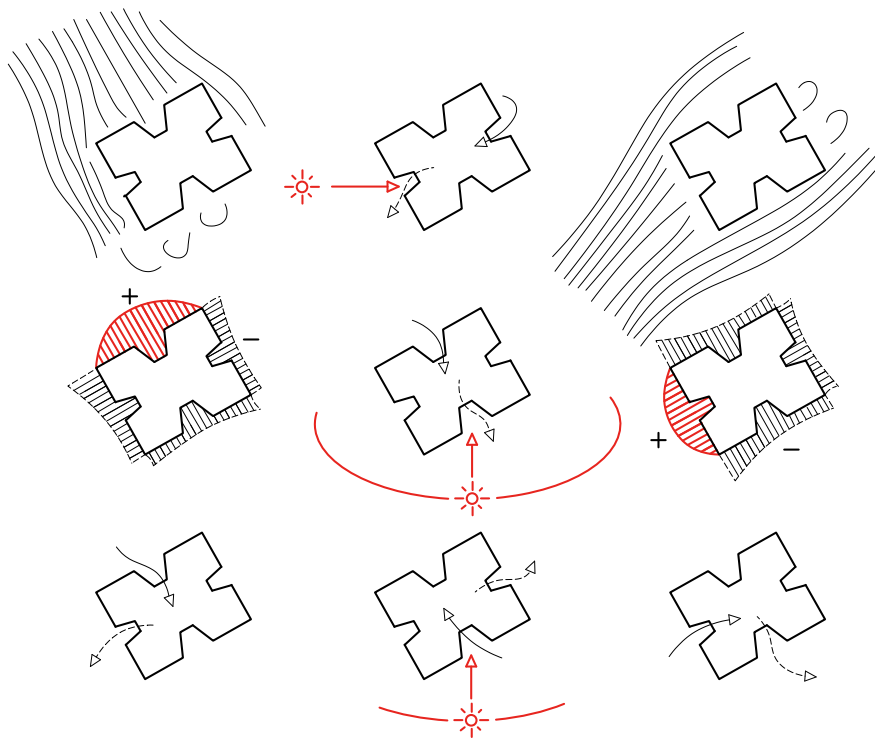

Amorepacific tower design concept, Delugan Meissl Associated Architects

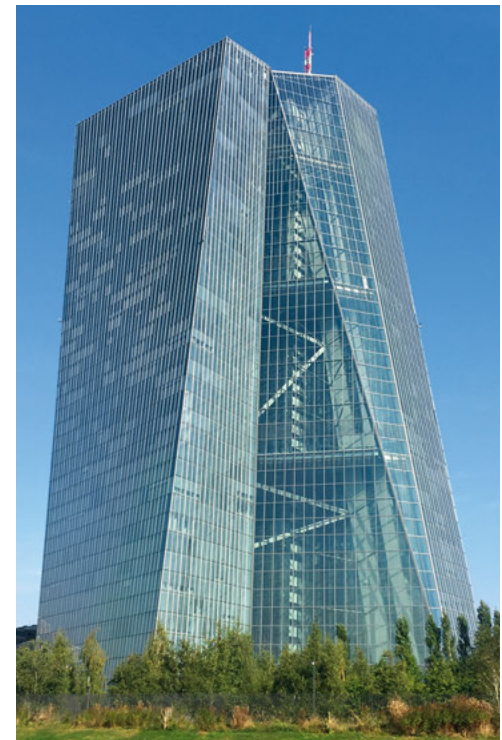

European Central Bank HQ, Coop Himmelb(l)au architects

functions provided by typical present-day complex multilayered external wall constructions – with all their associated problems relating to embodied energy, disposal, etc. – and by mechanical ventilation systems with heat recovery systems. In a sense, this facade concept replaces the traditional wall construction with inhabitable space.

At the new campus of the Medical University of Graz, designed by Riegler Riewe Architekten, the buildings are orientated with the long axis running north-south on account of wind considerations related to the local microclimate. The external shading devices were designed as vertically aligned perforated metal elements which are automatically controlled and allow daylight and views while blocking solar radiation. In this way, the movement of the shading elements expresses the reaction of the building to its external environment.

The facade developed for the European Central Bank headquarters building in Frankfurt (Coop Himmelb(l)au architects) incorporates an array of devices which offer a high degree of selectivity and adaptability, including highly selective glass coatings, automati-

cally controlled movable solar shading and elements specially developed to provide natural ventilation for this high-rise building in a windy environment. The building facade presents a monolithic homogeneous exterior appearance, demonstrating that similar energy design approaches can lead to very different architectural expressions and concepts.

The proposal for the new headquarters building for Amorepacific in Seoul, designed by DMAA Delugan Meissl Associated Architects, includes vertical sky gardens on all sides of the building. The sky gardens act as transitional spaces, mediating between inside and outside and also providing the office spaces with filtered and tempered fresh air. Ground water is used to temper the incoming air and dehumidify it in summer. The resulting condensate in summer is used directly for irrigation of the planting and vegetation, in a symbiotic relationship between humans and nature, where humans receive the dried cooled air and the vegetation receives the condensed water.

The Amorepacific building itself is, as are most buildings, a static object in a sea of ever-changing

conditions. However, the building skin and systems react to these conditions in a dynamic manner. The fresh air intakes of the decentralised air-handling units installed on the office floors draw air from the sky gardens. These are interconnected so that the orientation of the fresh air intake is dynamically adapted to suit the prevailing conditions: in winter, outdoor air is taken from the sky garden with the highest temperature, in summer, from the area with the lowest temperature. The sky gardens are also utilised to support the driving pressure required to distribute air to the occupied spaces, by employing the stack effect on the hotter side of the building (sky gardens connected vertically) in combination with the static pressure of the prevailing wind.

The École Centrale Paris (CentraleSupélec) engineering school building on the campus of the Université Paris-Saclay, designed by OMA architects, demonstrates a new university campus building typology. It achieves high energy performance by utilising synergetic interactions between the various uses, creating a new form of campus space under a “climate envelope” composed of a PTFE foil roof and

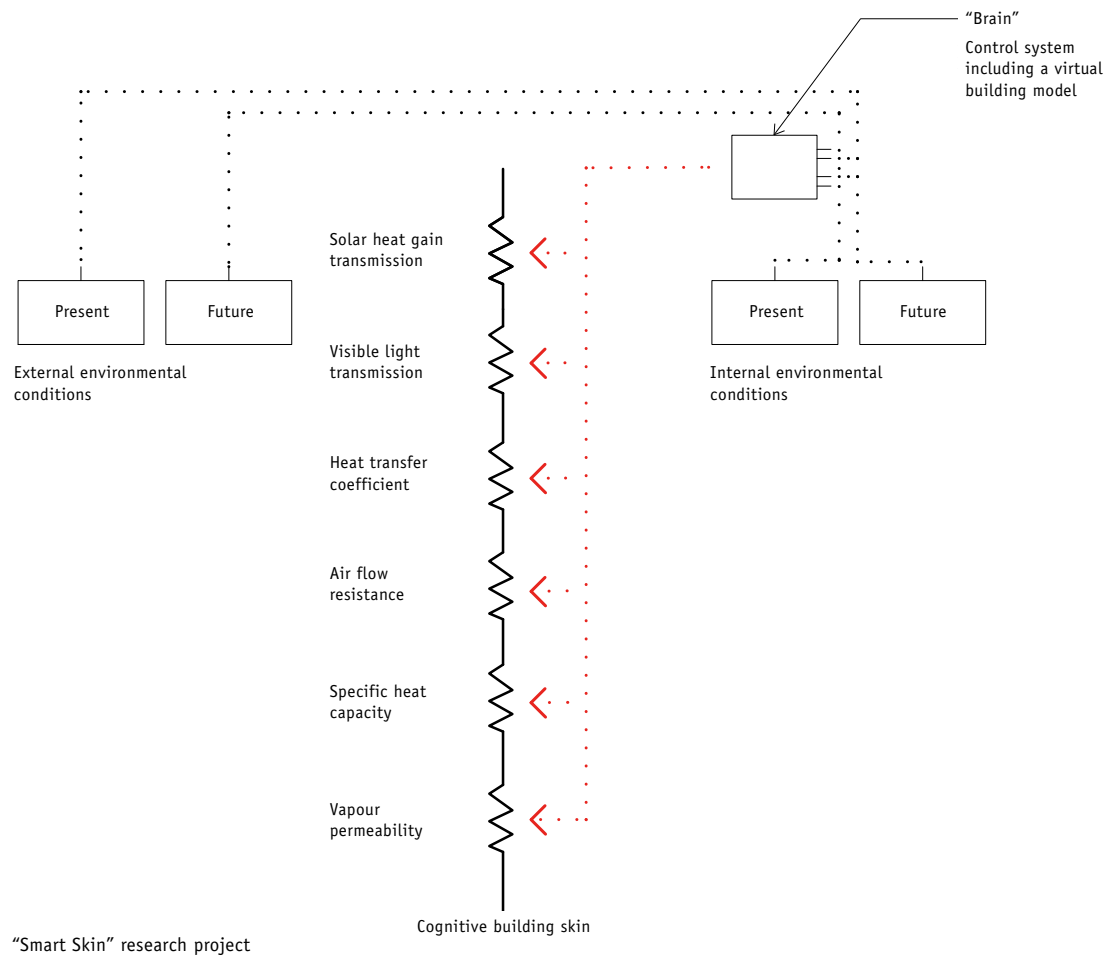

"Smart Skin" research project

glass facades. The building encloses teaching spaces, laboratories and offices within a climate envelope, so that the in-between spaces form an indoor campus. Compared with traditional typologies, the design offers major advantages in terms of communication among research staff and students as well as flexibility and adaptability regarding future changes in use and the configuration of offices and laboratories. Placing the climate envelope around the entire building volume instead of individual office and laboratory cells increases building compactness, reduces the amount of heat transfer area, and creates unique spaces between the office and lab cells.

Within the climate envelope, a macroclimate is created, largely by passive means, which is not as closely controlled as the internal environments inside the laboratories and offices. The hall is conceived as a transitional space between the internal and external environments, supporting and enhancing the campus atmosphere and informal communication. The potential for enhanced communication offered by the macroclimate in the climate envelope

is significantly increased in the climate of Paris. This building typology enhances both communication between people and synergetic energy flows between the many diversified uses under its roof, transferring surplus heat from the laboratories to spaces which require heat, such as the offices. The proposed "Smart Skin" concept goes far beyond the strategies we have been able to implement in practice to date. It also incorporates and uses forecast data relating to future weather and likely user behaviour (based on data of past experience and using an embedded artificial intelligence approach) as well as present-time data to select the optimal configuration of physical properties and thereby optimise performance. A novel dynamic simulation model, specially developed for the project, provides meaningful insight into the potential and possibilities. This type of model could also serve as a virtual model incorporated into the building's automatic control system to provide part of the intelligence necessary for the optimal performance of the smart skin. Further research will look at how the intended degree of adaptability can be physically accom-

plished: mechanical devices, fluid-filled cavities or smart materials which can change their physical and/or chemical characteristics.

The final goal is the development of adaptive facades, which automatically change their thermal and optical properties, constantly adapting to changing requirements by manipulation of variable parameters for thermal insulation, solar energy transmittance, light transmission, thermal energy storage, airtightness and moisture diffusion, in order to achieve the desired internal conditions with the least amount of energy expenditure. Investigations carried out in the first stage of this project show potential energy savings of up to 90% compared to conventional energy efficient facade systems today.

## ■ 2.2 Moving elements for active solar energy use in buildings

Arno Schlüter, Uta Gelbke

### **Solar energy: Towards active use as the new standard**

The sun as the most powerful natural source of renewable energy also has the greatest impact on the energy balance and indoor comfort of a building. Research and development in the field of facade design has concentrated primarily on achieving the best possible insulation against the effects of weather and on making passive use of solar energy by trapping heat in the interior and in solid parts of the building's structure around the openings. The desire for ever more transparency in facades, however, conflicts with these aims, despite continuous

improvements in the thermal insulation properties of glazing. The combination of dense, increasingly well-insulated building envelopes and large glazed surfaces exposed to the sun presents a problem: the interiors risk overheating.

Rather than blocking unwanted solar energy, active solar energy use makes it possible to make optimum use of the potential of the sun: production instead of insulation. Generating energy from the sun with building-mounted systems is one of the most effective means of making the switch to renewable energy sources. Buildings already have numerous surfaces that are exposed to the sun and are thus suitable

for energy generation: first and foremost, the roof, especially in less densely populated areas, as well as the facades in denser urban areas. By utilising this available potential, no other land surfaces need to be built upon for generating electricity.

As the interface between indoors and outdoors, the facade determines the air, light and heat balance of a building, and in turn the comfort of its users. The indoor and outdoor environments are both stochastic, i.e. their respective conditions vary and are not reliably predictable at any one moment. As such, the facade forms the boundary between two dynamic and unpredictable environments. Its vertical

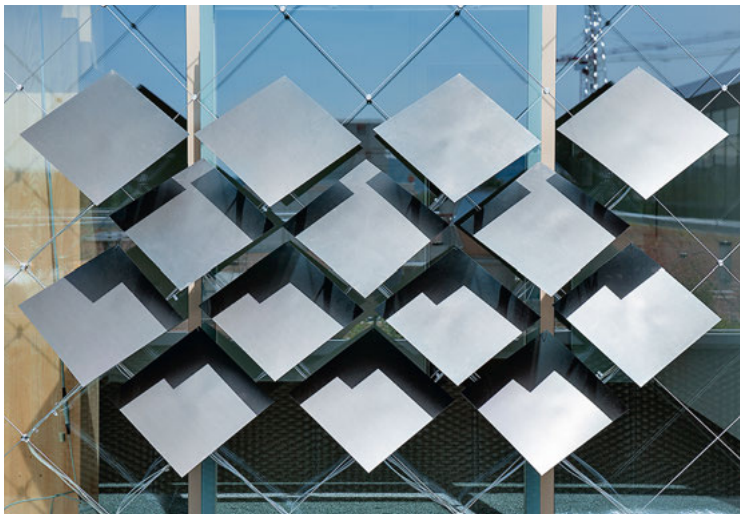

Adaptive Solar Facade (ASF) prototype mounted on the House of Natural Resources, ETH Zurich, 2015



Solar shading system of the Al Bahr Towers, AHR in collaboration with Arup, Abu Dhabi, 2013. PTFE-coated glass fibre mesh mounted on steel supports. Meteorological data on the position of the sun and from sensors are used to control the shading system.

alignment, however, means that it has less absolute potential for energy generation than roof surfaces, but also more potential at times of low angles of incidence and simultaneously high energy demand, such as in the mornings and evenings or in winter. In addition, passive and active approaches are more easily combined in the facade. To exploit these possibilities and respond to the volatile properties of the sun as a source of energy, the facade needs to be designed and conceived of more flexibly. How can moving parts of the building envelope make better use of the active and passive potential of solar energy? Window shutters are an obvious example: whether with hinged shutters, rotating

slats or extendable flaps or canopies, they allow a building's users to manually regulate incident light. Depending on the position of the sun and the needs of the user, they make it possible to control thermal heat gain and make passive use of solar energy. This seemingly simple building element therefore has a significant measure of complexity and versatility but is limited to each single use instance in front of the respective window.

A contrasting example is the solar shading system of the Al Bahr Towers in Abu Dhabi, which employs the same basic principle as the window shutter but is placed as a continuous layer in front of the glazed facade, enclosing it: a dynamic, modern interpreta-

tion of the traditional grid-like screens in Islamic architecture. Large-scale modules are mounted to form a honeycomb-like geometry, and individual clusters of shutters can be opened or closed. The system allows solar heat gain and glare effects in the extreme climatic conditions of Abu Dhabi to be controlled without impairing the incidence of daylight.

Nevertheless, none of these examples actively generate energy from the solar radiation.

#### **The adaptive solar facade (ASF)**

The A/S Research Team at ETH Zurich has developed a movable, adaptive facade system that overcomes

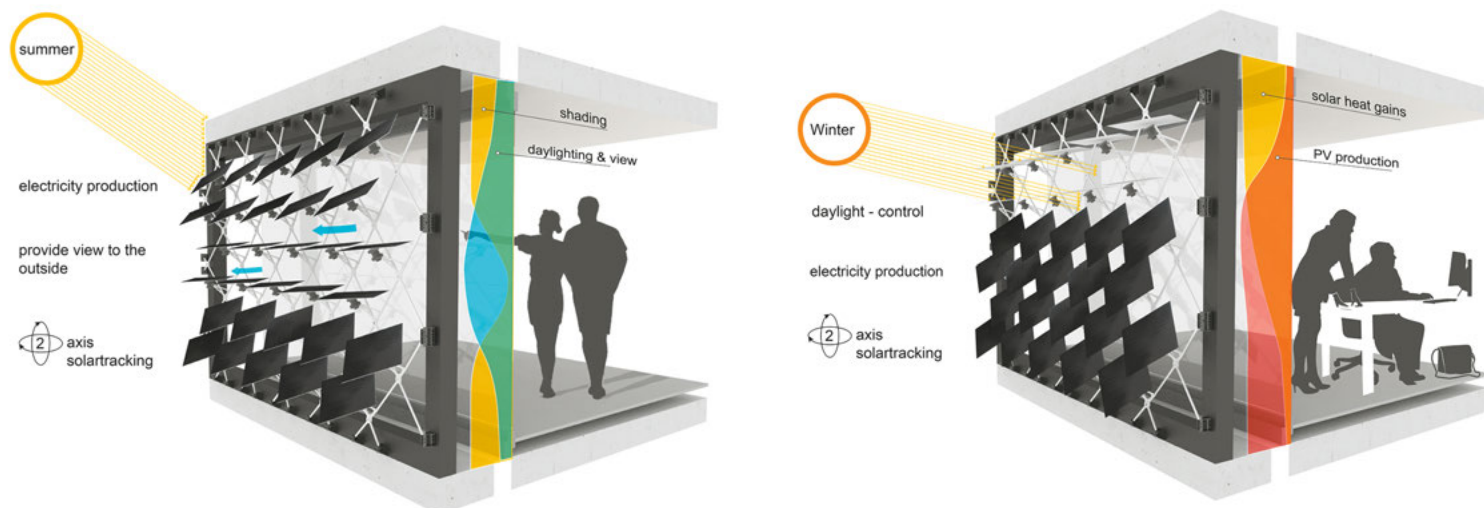

Functions of the different parts of the ASF during the summer and winter months. Image from Svetozarevic et al.<sup>1</sup>

the static character of building envelopes and can respond to different lighting conditions and user requirements while also providing an optimal supply of solar energy to the building: the adaptive solar facade (ASF).<sup>2</sup>

The ASF consists of individual modules mounted on a cable or bar net on the building facade. The modules can rotate individually on two axes and can influence light and heat gain in the interior by allowing more or less solar radiation through the windows. At the same time, they produce electricity via highly efficient thin-film solar cells on their outer faces, which align to follow the course of the sun. The adaptive solar facade also has a very low weight, which considerably increases its potential for application compared with conventional photovoltaic modules. It is suitable for installation on both new and existing buildings.

The ASF should be understood as an integral component of an overall building system. Its effectiveness depends on factors such as orientation and location, but also on how it works in harmony with other building services such as lighting, heating and ventilation. In buildings with inefficient technical installations and/or high levels of carbon emissions, which is often the case with existing buildings, it may make more sense to use incident solar radiation to preheat the interior. The segments can be positioned independently so that parts of the facade shade parts of the interior, while other

segments deflect incident light onto the ceiling, reducing the need for artificial lighting. As such, the appearance of the architecture changes dynamically as the modules respond continuously to changes in their surroundings. The adaptive solar facade is also able to store energy: in the event of excess energy gain, the power is converted into compressed air, which is stored and used later – for example during poor weather – to move the modules.

The facade system was designed and developed using a parametric design environment. With the help of a parametric geometric model created in Rhino/Grasshopper, calculations and simulations of different areas were combined, e.g. a specially developed high-resolution simulation of solar irradiation, shading and electrical interconnection of the solar modules with structural calculations for the load-bearing structure.

#### Hybrid actuator

Thanks to an innovative hybrid actuator, the ASF modules can rotate freely about two axes. The actuator draws on techniques used in the field of soft robotics for the production of actively deformable components, mainly for use with biomimetic robots. The advantage is the low material input required and a construction without complex mechanical parts, which would be hard to implement reliably under the harsh weather conditions to which facades are exposed. The actuators and thin-film solar

panels mounted on them are moved by compressed air introduced into or withdrawn from specially created chambers in the material. Their compliant structure makes them particularly resistant to external influences. Their ability to deform continuously combined with the muscle-like driving mechanism means they can respond to changes with a wide radius of movement and are simple to integrate into the facade unit.

To be able to optimally track the position of the sun, and also respond to changing conditions and solar input outside and inside, the solar cells must be able to point at different angles in all horizontal and vertical axes. The actuator consists of three cylindrical air chambers arranged symmetrically about the centre and held by discs at the top and bottom. Valves control the air flow: air is pumped in or out causing the actuator to deform, in turn adjusting the orientation of each individual module. The CIGS photovoltaic cells are laminated directly onto the aluminium panel and currently achieve an efficiency of 12–15%. The actuator weighs about 200 g, while an entire module, including mounting bracket, weighs about 800 g.

#### Energy gains and savings using the adaptive solar facade

The effectiveness of the facade system was tested using four 1:1 prototypes. Control concepts and algorithms were developed to ensure that the facade

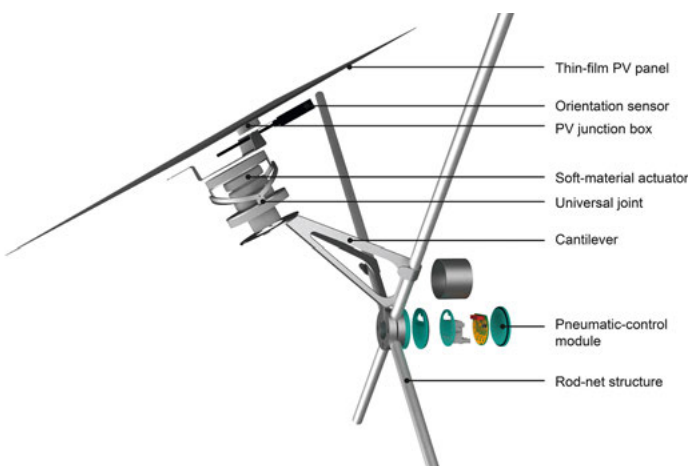

Construction principle of an ASF module. Image from Svetozarevic et al.<sup>3</sup>

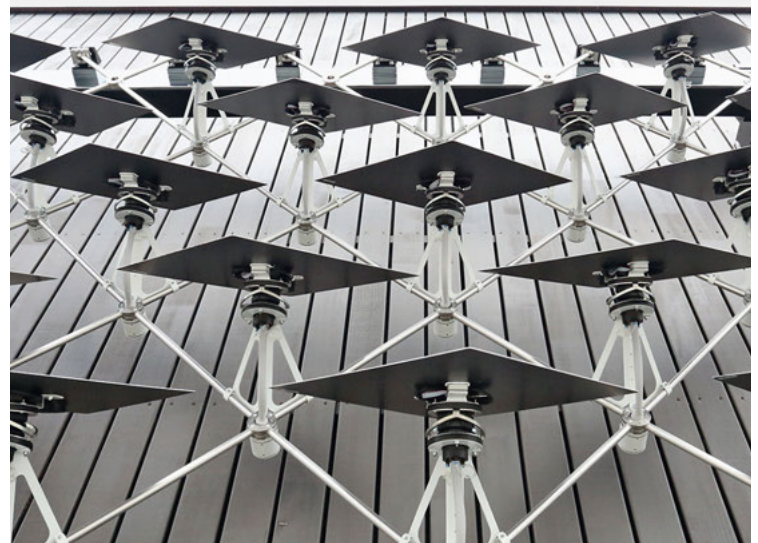

Detail of the ASF prototype on the NEST building, EMPA Campus, Dübendorf, 2017

remains in an optimum state. In terms of solar yield, a sunny day in Zurich showed an energy increase of between 61% and 73% over static modules at the reference position, i.e. vertically and parallel to the facade.<sup>4</sup>

Life cycle calculations have shown that the ASF can make up for the energy required for its manufacture after approx. 18 months and the emissions after approx. 24 months.<sup>5</sup>

The aim of the adaptive control system is to assist the facade in reacting to changing indoor and outdoor conditions as well as in adapting its behaviour based on interaction with the user. The system learns from these interactions in combination with other parameters such as weather, day of the week, indoor climate, etc. The system can then use these interaction data to determine its own behaviour. If the user prefers conditions different from those suggested by the system, the facade settings can be overridden at any time, thereby contributing to the system's intelligence once more.

#### **Economic factors, design options and "solar networks": An outlook**

For the large-scale implementation of moving components for active solar energy use in buildings, economic and social factors are, of course, decisive. In mass production, both the hybrid actuators and the CIGS panels have the benefit of low manufacturing costs. All structural components such as the

cable or bar net and the mounting brackets can be digitally fabricated from the digital model. Current developments in the 3D printing of multi-material building components will make it cost-effective to produce individual components, so that the hybrid actuators can be realised in a single component by 3D printing materials with different degrees of stiffness.

In addition to economic aspects, design freedom is also a decisive factor. The design of ASF facades can be varied freely within certain parameters with respect to size, distance, angle, surface, transparency and controllability of the modules. Further design possibilities will follow, with the development of new approaches and methods for printing as well as the development of colour filters. Design studies have shown that the panels can be realised using coloured, translucent or transparent modules.

In an urban-scale study, movable elements with reflective modules were shown to be able to reflect solar radiation onto the facades of neighbouring buildings not exposed to direct sunlight. Those buildings can then use solar radiation for daylight and to generate electricity or heat. Using such "solar networks", the supply of solar radiation could be distributed across several buildings to optimise the balance between the supply and demand of energy from the sun.

1 Svetozarevic, Bratislav; Begle, Moritz; Jayathissa, Prageeth; Caranovic, Stefan; Shepherd, Robert F.; Nagy, Zoltan; Hischier, Illias; Hofer, Johannes; Schlüter, Arno: "Dynamic Photovoltaic Building Envelopes for Adaptive Energy and Comfort Management", *Nature Energy*, 8 July 2019, <https://doi.org/10.1038/s41560-019-0424-0>.

2 Nagy, Zoltán; Svetozarevic, Bratislav; Jayathissa, Prageeth; Begle, Moritz; Hofer, Johannes; Lydon, Gearóid; Willmann, Anja; Schlüter, Arno, "The Adaptive Solar Facade: From concept to prototypes", in: *Frontiers of Architectural Research*, 5.2, 2016, pp. 143–156.

3 Svetozarevic, Bratislav; Begle, Moritz; Jayathissa, Prageeth; Caranovic, Stefan; Shepherd, Robert F.; Nagy, Zoltan; Hischier, Illias; Hofer, Johannes; Schlüter, Arno, "Dynamic Photovoltaic Building Envelopes for Adaptive Energy and Comfort Management", *Nature Energy*, 8 July 2019, <https://doi.org/10.1038/s41560-019-0424-0>.

4 Svetozarevic, Bratislav; Nagy, Zoltán; Hofer, Johannes; Jacob, Dominic; Begle, Moritz; Chratzi, Eleni; Schlüter, Arno, "SoRo-Track: A two-axis soft robotic platform for solar tracking and building-integrated photovoltaic applications", in: *2016 IEEE International Conference on Robotics and Automation (ICRA)*, Piscataway, NJ, 2016, 6, pp. 4945–4950.

5 Jayathissa, Prageeth; Jansen, Michiel; Heeren, Niko; Nagy, Zoltan; Schlüter, Arno, "Life cycle assessment of dynamic building integrated photovoltaics", *Solar energy materials and solar cells*, 156, 2016, pp. 75–82.

## ■ 2.3 Robustness and autoreactivity: Temperature regulation using thermal actuators

Philipp Lionel Molter, Thomas Auer

Over the past decades, efforts to improve energy efficiency and living comfort have been mainly driven by technology. However, technology-intensive building services have not led to the desired reduction in energy consumption, not least because complex room conditioning systems often fail to function as planned. Numerous scientific studies have shown that the measured energy consumption is sometimes as much as three times higher than the predicted consumption<sup>1,2</sup> and that the intended energy efficiency in operation is only achieved – if at all – after a period of adjustment.<sup>3,4</sup> As ongoing monitoring of energy consumption is only rarely carried out, it is probable that a large number of new buildings consume significantly more energy than originally calculated in the planning process. This difference is known as the performance gap. A significant contributor to this is the difference be-

tween the assumed and the actual preferences of the users.<sup>5</sup>

As a consequence, discussions about the merits of “high-tech” and “low-tech” have once again resurfaced. These terms are used frequently and in a variety of ways without there being a more precise and generally valid definition of their meaning in the context of the building sector. One way or another, “low-tech” does not simply mean the minimisation of technology, but is instead more usefully described as follows:

- simple construction with simple details
- simple floor plans and building organisation
- little or no heating, ventilation and air-conditioning technology (HVAC)
- little (and if so, intelligent) process measuring and control technology

In this context, it makes sense to use more precise terms and more tangible strategies. Two new terms can help here: robustness and autoreactivity. Robustness describes the optimisation process of a dynamic system and therefore describes an intuitive understanding of “low-tech”. Robust behaviour or robust optimisation can be described scientifically.<sup>6,7</sup>

### Robustness

In many industrial sectors, robust optimisation is already state of the art, but it has yet to find its way into the building industry.<sup>8</sup> Here, there is no shortage of uncertain boundary conditions, for example in user behaviour, in systems that are not operating optimally or, at a broader scale, in climate change. Up to now, planning processes have aimed to find the so-called global minimum for the respective task, and uncertain boundary conditions

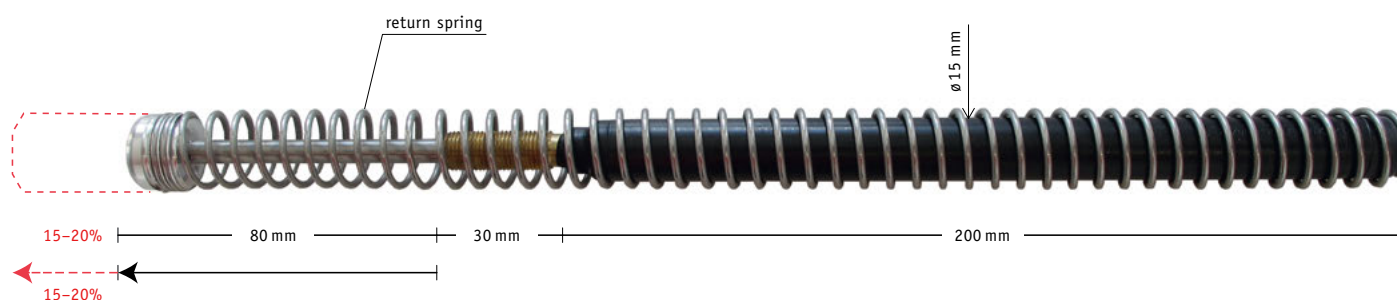

Cylindrical thermal actuator with return spring

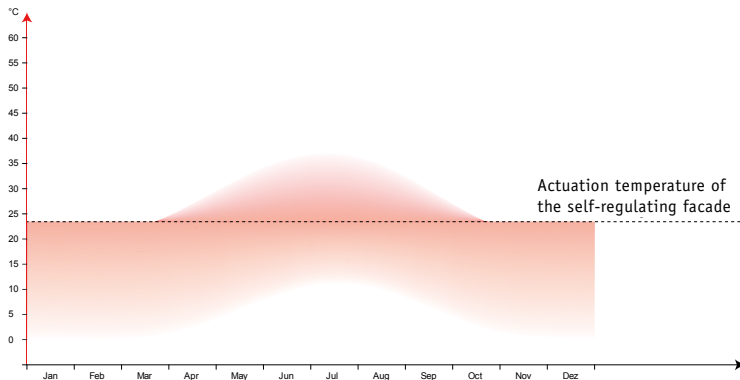

Autoreactive facade ventilation: temperature difference in the facade cavity

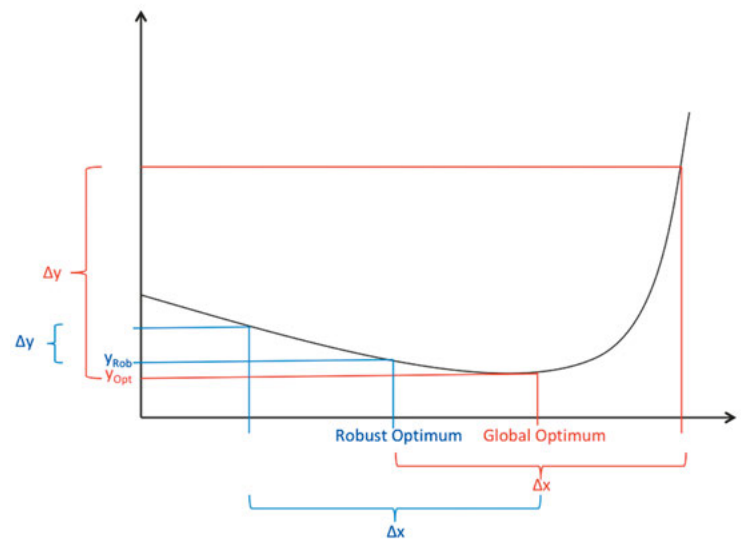

Comparison of the global and robust optimum

can have a considerable effect on the result. By contrast, they have only a minor effect on the result of robust optimisation.

If, for example, we consider the proportion of window area in a wall, the energy requirement decreases up to a certain point due to the improved use of daylight. However, if the share of window area increases further, the energy requirement increases exponentially (more energy is required for cooling, but energy for artificial lighting does not decrease), especially when the user exerts individual influence on the sun protection system in place.

### Adaptivity

A second central aspect is adaptivity. The term “adaptivity” is mostly used in natural sciences such as biology. However, in recent years adaptive systems have also developed and spread rapidly in the engineering disciplines and in the field of artificial intelligence. Adaptivity describes the ability of a system to control or independently adapt to changing environments and conditions. Adaptive architecture is constantly changing, adapting flexibly to conditions such as the position of the sun, and is therefore no longer considered static, but rather acts dynamically in a manner much like nature. Alongside technical aspects such as improving the performance of buildings, the aesthetics and cultural view of architecture also changes. These changes are most apparent in the building envelope. This is where adaptive systems have the greatest effect – not only visually, but also technically and in terms of energy efficiency.

### Adaptivity: Static or dynamic

The concept of adaptivity encompasses two basic strategies. For one thing, adaptivity can be seen as a static state that is the result of a process. In such cases, a system is adapted to a certain situation or a certain place. This could, for example, be a fixed external sunshading device with a depth already adapted to suit its orientation, e.g. south-facing. The building element is tailor-made for that particular facade, and should the same system be used in another situation, its geometry needs to be recalculated accordingly, most likely resulting in a different shape.

For another thing, adaptivity can also be understood as a dynamic process that is itself continually changing and changes over time. In this case, various phases are considered which correspond to the different configurations of the designed component. Through the action of external energy input (thermal, electrical, etc.), a reversible transformation takes place, i.e. the dynamic process adapts to the various phases. An example might be an external sun protection louvre that independently rotates to face the sun with the aim of optimally improving the indoor climate.

### Adaptive or autoreactive

Dynamic processes can be further differentiated according to their respective processes of transformation, i.e. the way a particular transformation takes place. We distinguish between indirect or direct transformations. Most control processes of adaptive

systems have three phases: 1. sensing, 2. processing, and 3. acting.

Controlled adaptation usually requires an external energy supply, for example to activate the regulation or control of the sensors and actuators. External and other sensors monitor the ambient conditions and trigger corresponding changes to the system. If the process takes place directly and immediately, we refer to autoreactive systems. Here, sensing and acting are directly coupled without the additional step of processing the captured data. Autoreactive systems therefore react directly to external influences without the use of control technology. Such systems typically require some form of external energy input, whether electrical or otherwise, to trigger the adaptive process. An advantage of autoreactive systems lies in their reduced complexity and in their self-sufficiency, because they operate decentrally and need not be incorporated into comprehensive control systems.

### Autoreactive systems in architectural applications

As energy standards become increasingly stricter in the coming years, the need to improve the adaptability of building envelopes will become increasingly essential. Office buildings, in particular, are predestined candidates due to their high proportion of glazing. Depending on their orientation and colour, even building envelopes in Central Europe can reach temperatures of up to 80 °C. In winter, heat losses through the building envelope result in correspondingly high heating loads, especially when

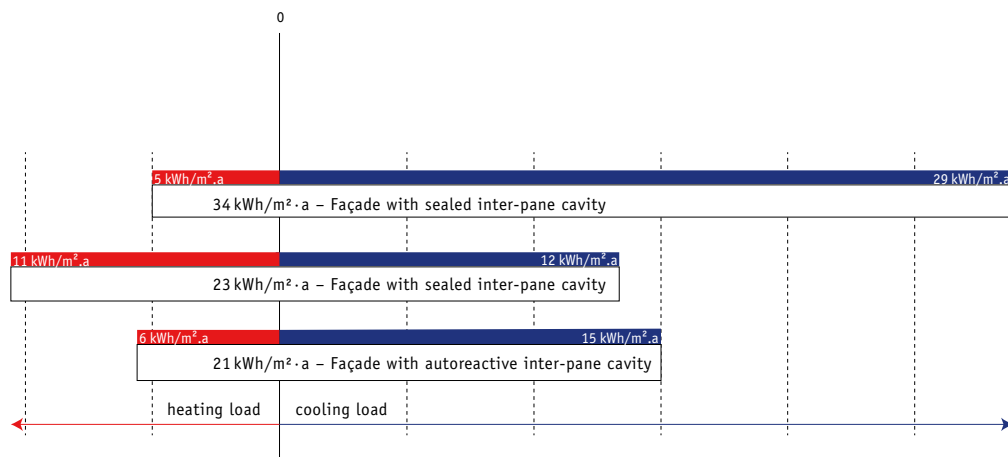

Double-skin glass facades in comparison: energy consumption per year and m<sup>2</sup> surface area



Model of a double-skin facade with an autoreactive actuator

the U-value of the glazing is inadequate. However, the desire for bright interiors and direct, expansive views of the outside world is continuing to contribute to an increase in the proportion of glazing in buildings around the world, not least because adequate daylight is important for the sense of well-being, especially in winter.

In the 1990s and early 2000s, many administrative buildings were built with extensive glazing, sometimes with twin-leaf building envelopes where external sunshading mechanisms were placed in the air space between the outer and inner layers of glazing to protect them from the effects of wind and weather. The heat absorbed by the solar shading elements is given off into the interstitial space within the facade, causing the air within to warm up and in turn to transfer heat to the interior. To minimise this effect, many high-rise buildings with twin-skin facades have vents in the outer layer to allow the trapped heat to escape. While this permanent vent prevents the air within the facade and the adjacent surfaces from overheating in summer, it is suboptimal in winter where air circulation compromises the thermal insulating effect of the cavity.

### The dynamic facade

A newly developed, autoreactive facade ventilation system with a self-regulating dynamic system prevents overheating of the space within the facade and at the same time reduces soiling. Drawing inspiration from the human skin, the space between the facades opens and closes automatically in a kinetic process in response to external temperature fluctuations.

The system is based on traditional box windows with textile blinds or жалюзи as sunshading arranged in the cavity of the facade to protect it from wind and weather. The outer glazing of the box window can open outwards parallel to the plane of the facade using a scissor mechanism and is anchored to the frame at the corners via four paraffin-filled thermal actuators. When the air temperature between the panes rises above 23 °C, the paraffin expands in volume, causing the actuator cylinder to push the outer glazing layer outwards by 8cm, creating an open slot between the frame and the pane. Cooler outdoor air can now flow into the cavity and the warm air inside the cavity flows out naturally, because high-rise facades are subject to constant air pressure or air suction; thus ensuring proper ventilation of the air cavity. The cavity cools down, reducing heat transmission to the interior in summer, and in turn the need for cooling the rooms within the building. When the temperature drops below 19 °C, a return spring in the telescopic paraffin cylinder closes the gap. As paraffin has a relatively short reaction time, this process can happen several times per hour.

This “breathing movement” of the facade is visible from outside. In winter, the facade module remains closed on cold days, increasing the overall U-value of the facade, as the cavity functions as a thermal buffer zone. The reduced transmission heat loss means that indoor heating can be reduced by up to 45% (depending on the U-value of the glazing) compared to a permanently ventilated cavity. Over a period of one year, the energy required for cooling

the interiors could be reduced by almost 50% compared to permanently closed facades.

It is important to note that the cavity within the facade module is typically open for only a fifth of the year. This also considerably reduces the frequency of cleaning and maintenance, leading to a significant reduction in costs compared to permanently ventilated double-skin facades. In addition, the reduced temperature level prevents damage to the shading device which, in a closed cavity, can easily reach temperatures of up to 90 °C, causing strain to the blind motors and their kinetic components.

From an architectural perspective, it is significant that this technical solution does not restrict design freedom. The functionality has very little effect on the facade design and is almost invisible. A further advantage is durability: the kinetic components are well-proven – they have been used for decades for the ventilation of greenhouses – and very low maintenance, requiring no electricity. The active ingredient paraffin is found in most domestic heating thermostats as a low-maintenance and low-cost means of regulating the heat output of static heaters.

The system could be enhanced with a moisture-regulating polymer to prevent condensation in such double-skin modules. The advent of such dynamic facade modules has the potential to revolutionise facade design: they employ simple technologies as a means of reducing the need for building services, and at the same time increase user comfort.



Closed state of operation in winter improves the U-value

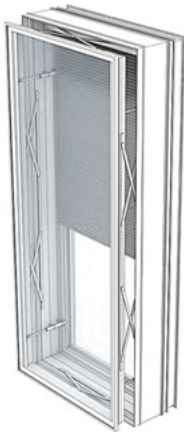

Open state of operation when the temperature is hot in summer

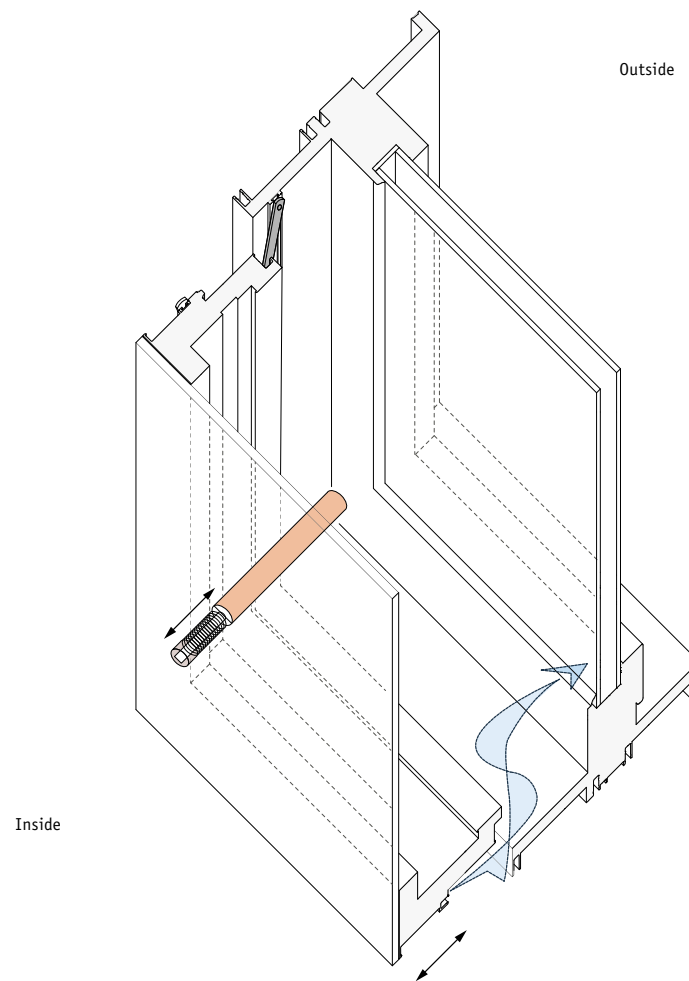

Parallel opening vent: sectional isometric of a twin-skin box-window with autoreactive facade ventilation

- 1 Oberste Baubehörde im Bayerischen Staatsministerium des Innern, für Bau und Verkehr: *e% – Energieeffizienter Wohnungsbau. Abschlussbericht der wissenschaftlichen Begleitung des Modellbauvorhabens*, TU München/Hochschule Augsburg/Hochschule Coburg, 2017.
- 2 Schneider, B.: *Nutzerverhalten bei Sanierungen berücksichtigen. Bine-Projektinfo 02/2015*, E.ON Energy Research Center of RWTH Aachen, 2015.
- 3 Jazizadeh, F. et al.: "Personalized Thermal Comfort Driven Control in HVAC Operated Office Buildings", *Computing in Civil Engineering – Proceedings of the 2013 ASCE International Workshop on Computing in Civil Engineering*, 2013, pp. 218–225.
- 4 Fisch, M. N. et al.: *EVA – Evaluierung von Energiekonzepten für Bürogebäude, Abschlussbericht*, TU Braunschweig, Institute for Building Services and Energy Design, 2007.
- 5 Delzende, E. et al.: "The impact of occupants' behaviours on building energy analysis: A research review", *Renewable and Sustainable Energy Reviews*, 80, 2017, pp. 1061–1071.
- 6 Maderspacher, J.: *Robuste Optimierung in der Gebäudesimulation. Entwicklung einer Methode zur robusten Optimierung für die energetische Sanierung von Gebäuden unter unsicheren Randbedingungen*, PhD thesis, TU München, 2017.
- 7 Rhein, B.: *Robuste Optimierung mit Quantilmaßen auf globalen Metamodellen*, PhD thesis, University of Cologne, 2014.
- 8 Nguyen, A.-T. et al.: "A review on simulation-based optimization methods applied to building performance analysis", *Applied Energy*, 113, 2014, pp. 1043–1058.

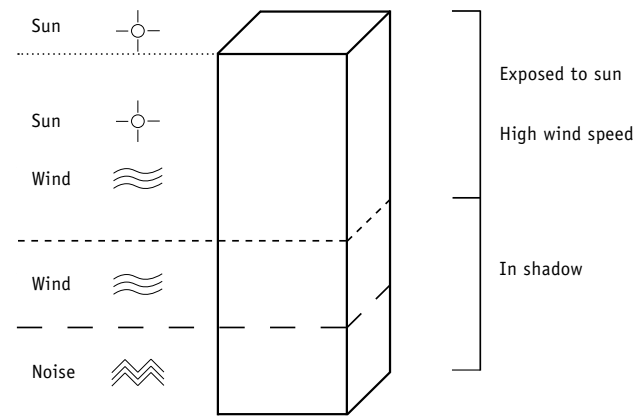

Energy creation at different levels of a building from different sources

## ■ 2.6 Energy generation in the city of the future

Werner Jager, Laura Bugenings, Markus Schaffer

By the year 2050 an estimated 70%<sup>1</sup> of the world's population (which by then is projected to be around 7 billion<sup>2</sup>) will live in urban environments. Such concentrations of people will inevitably result in increasingly dense cities. Where in the past urban environments expanded horizontally, tomorrow's cities will grow increasingly in height – with consequences for the future functionality of building envelopes: the surface area of the facades and roofs will increase in proportion to the footprint. To exploit this potential, the facades of the future will need to be more than simple building envelopes and fulfil additional functions, including:

- energy generation
- illumination
- cleansing and preconditioning of outdoor air
- absorption of:
  - heat
  - air pollutants
  - outside noise

Today's large metropolitan cities such as Frankfurt am Main illustrate the challenges we are facing along with possible approaches to tackling them. A major issue for large cities is the high level of noise throughout the day, which impacts on the

usability of urban spaces, as does the problem of natural ventilation. A further challenge of dense building environments is the wind effects, especially around high buildings, that in certain building constellations and weather conditions can result in significantly increased wind speeds.

Alongside ongoing demand for living space, the continuing rise in energy consumption in cities presents planners with a challenging problem. A possible solution lies in decentralised neighbourhood strategies. Innovations such as piezoactive coatings and membranes make it possible to harvest energy from sound and wind using building facades,

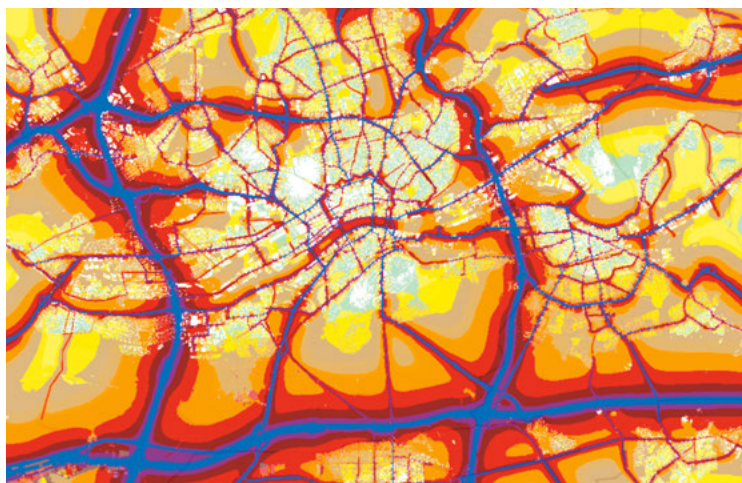

Noise map for Frankfurt am Main and its surrounding hinterland



Noise map for the centre of Frankfurt am Main with the main railway station on the right

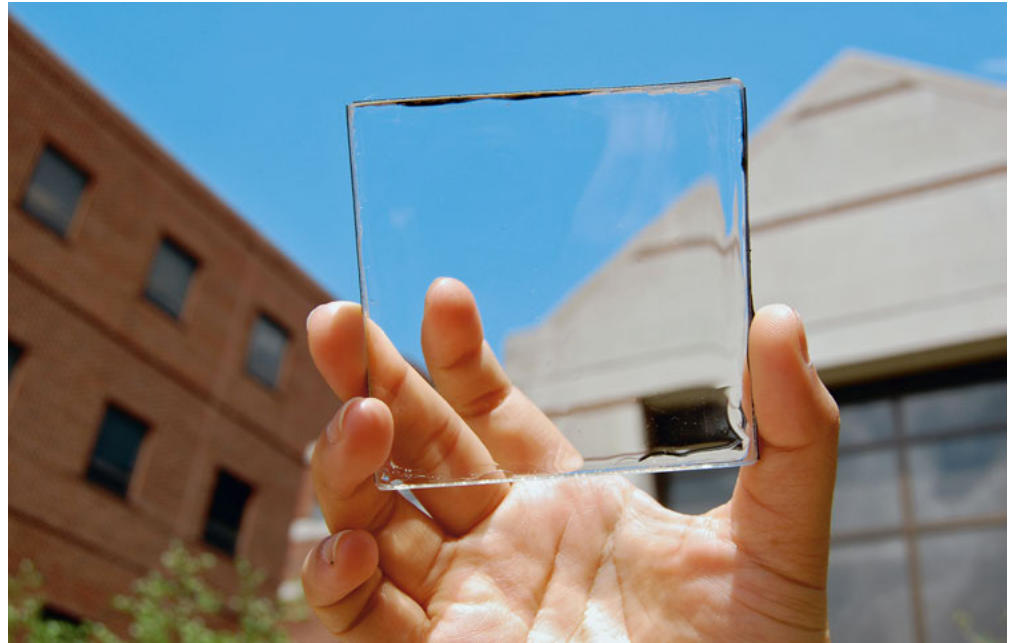

Transparent photovoltaics: wavelength-selective luminescent solar concentrator

including those that were previously of limited use for energy generation because they lay in shadow. Advances in selective transparent photovoltaics will likewise make it possible to exploit the highly transparent surfaces of modern architecture without impairing user comfort, which up to now have mostly been unsuitable for photovoltaic systems.

### Transparent photovoltaics

In recent years, the trend towards photovoltaics has stagnated at a share of around 6% of electricity generation.<sup>3</sup> Considerable potential therefore remains unused,<sup>4</sup> often due to the difficulty of incorporating the requirements of photovoltaic systems into architectural designs. The opacity and striking visual appearance of conventional photovoltaic systems frequently makes it hard to integrate them into existing and new buildings.

Researchers at the Massachusetts Institute of Technology (MIT) and Michigan State University (MSU) have developed a transparent photovoltaic system that could provide a solution for such architecturally challenging situations.

There are two principal types of transparent modules: opaque and non-selective versus UV/NIR-selective photovoltaic cells. With non-selective modules, transparency is achieved using thin but opaque layers. Selective modules, on the other hand, are themselves transparent to the greater spectrum of visible light, and generate electricity only from infrared and ultraviolet light.<sup>5</sup>

### Composition and efficiency

The requisite physical properties of selective photovoltaic systems are a product of their special construction. The PV coating, consisting of many thin layers, is applied to glass, plastic or a transparent carrier material. In the middle of the coating are active layers that absorb UV and NIR (near infrared) light and transfer the energy via two transparent electrodes into an external circuit. A selective reflector ensures that UV and NIR light is reflected to the active layers. An anti-reflective coating on the outer surface helps to improve the quantity of incident light by reducing reflections. The typical average visible-light transmissivity (AVT) of selective modules lies between 10% and 86% at a degree of utilisation of 1% and 9.8%. By comparison, conventional windows have an AVT of 15% to 90% and double glazing with a low-emissivity coating of up to 70%. In general, components with values above 60% appear transparent and neutral to the human eye.<sup>6</sup>

### Looking ahead

Transparent photovoltaic systems (TPV) could in future become a standard feature of glazing that is exposed to the sun, opening up great potential for generating electricity in cities without conflicting with architectural design aims. The fact that TPV coatings are permeable to the visible light spectrum but impermeable to infrared light has an additional benefit: it helps prevent undesirable heat gain.<sup>7</sup>

### Piezoelectrics

The piezoelectric effect, discovered by the brothers Jacques and Pierre Curie in 1880, describes how certain materials react to externally applied forces by producing an electrical voltage. These materials also exhibit an inverse piezoelectric effect in which, when a voltage is applied, their geometry changes. The piezoelectric effect only occurs in materials with a perovskite structure: “The chemical composition is a divalent element  $A^{2+}$  (e.g. barium or lead), a tetravalent element  $B^{4+}$  (e.g. titanium, zirconium or tin) and oxygen  $O_3^{2-}$ .”<sup>8</sup>

### Current applications

The current use of piezoelectric materials falls into two distinct categories: actuator technology in which a material deforms in response to a signal, and sensor technology in which a signal is produced in response to the deformation of the material.<sup>9</sup> When used as actuators, piezoelectric materials are, among other things, practically wear-free, fast responding, have excellent positional accuracy and high stiffness. They are used, for example, in inkjet printers for firing ink droplets, and in motor technology as injection valves for vehicle engines.<sup>10</sup> In medical or sonar sectors, oscillating piezoelectric materials are also used to generate sound and ultrasonic waves. As sensors, piezoelectrics are used in microphones or as knock sensors in vehicles.<sup>11</sup> Current research<sup>12</sup> has also given rise to a new field for piezoelectrics: the generation of energy through the conversion of sound energy. There are two basic approaches:

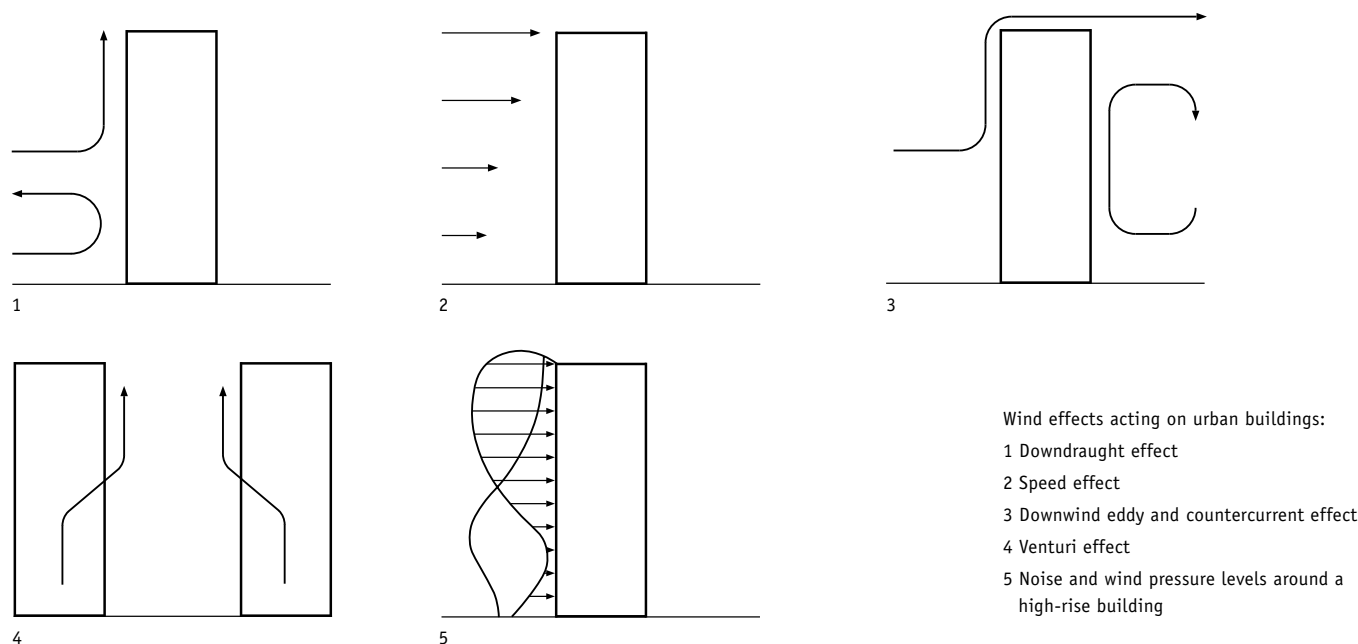

### Nanostructured materials

This approach employs nanorods such as zinc oxide structures on polymer substrates, which are typically produced in electrochemical or chemical processes.<sup>13</sup> The use of nanorods significantly increases the usable surface area and thus the yield compared to a regular surface. A research project on zinc oxide piezoelectrics conducted in 2014 at Queen Mary University of London in cooperation with Microsoft demonstrated the possibility of generating a voltage of up to 5 V in the laboratory from a surface the size of a smartphone.<sup>14</sup>

### Mesh membrane-based triboelectric nanogenerator

This approach uses a combination of the triboelectric effect (contact electrification of two materials creating a charge through friction) and electrostatic induction. In a prototypical test setup, the vibrating membrane is just 5 µm thick, and the spacers 50 µm thick. Initial research showed that in laboratory conditions, an area of 0.01 m<sup>2</sup> and a noise of 114 dB produces sufficient energy to power 138 LED lamps. In roadside field tests, power ratings of 0.1-0.8 V were achieved.<sup>15</sup>

### Future applications

In future, flexible mesh membrane-based triboelectric nanogenerators could be used as membranes in facade construction. Nanostructured material coatings on the surfaces of the building envelope could generate sufficient electricity through wind and sound to replace the external power supply for integral electronic components in the facade, such as locks and window openers.

Further products and developments are needed for tomorrow's building envelopes in order to be able to actively and passively influence the indoor and outdoor climate in urban contexts to create comfortable environments. Alongside satisfying user requirements, these will address and respond to factors such as:

- air quality
- sound quality
- thermal comfort
- visual comfort
- ease of control
- energy autonomy and mobility

Tomorrow's building envelopes will be multilayered and multifunctional, making it possible to design dynamically adaptive facades.

### Sound scattering on facades

More than 40 million people find ambient noise levels in urban areas in Germany intrusive, and some 13 million of these suffer from health problems as a result.<sup>16</sup>

To study the possible effects of building envelopes with geometric projections and recesses, 2D acoustic simulation methods (e.g. AFMG Reflex software) was used to assess how building geometry affects noise levels.

Building geometry can make an important contribution to reducing inner-city noise levels, especially in combination with

- facade materials with sound-absorbing properties and/or
- facade systems with vibrating panels and additional sound damping layers

as part of a holistic noise reduction concept for the facade in the context of its urban neighbourhood. The acoustic optimisation of wall surfaces offers further potential to minimise noise levels in urban areas. Whether using just foil absorbers (e.g. raumakustiks.de) or fabric wall cladding systems with underlying acoustic absorbers (e.g. sergeferrari.com), appropriate facade cladding systems can be created to respond to a respective frequency range.



Henninger Turm: a new residential high-rise designed by Meixner Schlüter Wendt Architekten, Frankfurt am Main



Facade design with surfaces facing in multiple directions developed by WICONA for the new Henninger Turm building, Frankfurt am Main, 2012–2017

- 1 Clos, J.: "United Nations Sustainable Development Summit 2015", <https://unhabitat.org/wp-content/uploads/2015/10/Statement-ED-Joan-Clos-UN-SDGs-Summit.pdf>, accessed on 12/04/2018.
- 2 "Population Division Probabilistic Population Projections, based on the World Population Prospects: the 2017 Revision", <http://esa.un.org/unpd/wpp/>, accessed on 02/05/2018.
- 3 AG Energiebilanzen e.V.: "Anteil der Photovoltaik an der Bruttostromerzeugung in Deutschland in den Jahren 2002 bis 2017", <https://de.statista.com/statistik/daten/studie/250915/umfrage/anteil-der-photovoltaik-an-der-stromerzeugung-in-deutschland/>, accessed on 03/04/2018.
- 4 TU Munich, Siemens AG: "Abschätzung des Photovoltaik-Potentials auf Dachflächen in Deutschland", *Symposium Energieinnovation*, 2010.
- 5 Traverse, C. J.; Pandey, R.; Barr, M. C. et al.: "Emergence of highly transparent photovoltaics for distributed applications", *Nature Energy* 2 (11) 2017, pp. 849–860, doi: 10.1038/s41560-017-0016-9.
- 6 Ibid.
- 7 Stauffer, N. W.: "Transparent solar cells: Generating power from everyday surfaces", 2013, <http://energy.mit.edu/news/transparent-solar-cells/>, accessed on 03/04/2018.
- 8 Hering, E., Martin; R.; Stohrer, M.: *Physik für Ingenieure*, Berlin and Heidelberg, 2016.
- 9 Bäker, M.: *Funktionswerkstoffe: Physikalische Grundlagen und Prinzipien*, Wiesbaden, 2014.
- 10 Czichos, H.: *Mechatronik: Grundlagen und Anwendungen technischer Systeme*, Wiesbaden, 2015.
- 11 Bäker, M.: *Funktionswerkstoffe*.
- 12 Fang, L. H.; Hassan, S. I. S.; Rahim, R. A. et al.: "Exploring Piezoelectric for Sound Wave as Energy Harvester", *Energy Procedia*, 105, 2017, pp. 459–466, doi: 10.1016/j.egypro.2017.03.341. – Fang, L. H.; Hassan, S. I. S.; Rahim, R. A. et al.: "Characterization of Different Dimension Piezoelectric Transducer for Sound Wave Energy Harvesting", *Energy Procedia*, 105, 2017, pp. 836–843, doi: 10.1016/j.egypro.2017.03.398. – Cui, N.; Gu, L.; Liu, J. et al.: "High performance sound driven triboelectric nanogenerator for harvesting noise energy", *Nano Energy*, 15, 2015, pp. 321–328, doi: 10.1016/j.nanoen.2015.04.008. – Briscoe J.; Dunn, S.: "Mobile phones come alive with the sound of music", 2015, <https://www.qmul.ac.uk/media/news/items/se/mobile-phones-come-alive-with-the-sound-of-music.html?ref=steemhunt>.
- 13 Briscoe, J.; Dunn, S.: *Nanostructured Piezoelectric Energy Harvesters*, Heidelberg 2014.
- 14 Briscoe, J.; Dunn, S.: "Mobile phones come alive with the sound of music".
- 15 Cui, N.; Gu, L.; Liu, J. et al.: "High performance sound driven triboelectric nanogenerator for harvesting noise energy".
- 16 Mack, B.: "Schallstreuung an parametrischen Fassaden", scientific project, Hochschule Augsburg, 2015.

## ■ 2.7 Movable and adaptive thin glass applications

Jürgen Neugebauer, Markus Wallner-Novak

The aspects of energy generation in the city of the future discussed in the previous article can be realised more effectively in combination with an additional dynamic, adaptive component: thin and ultra-thin glass.

The forms of movement within a facade need to be defined according to their principles. For movable and “developable” surfaces, translation, rotation, or a combination thereof in the form of one-, two- and three-dimensional curves are the primary principles.<sup>1</sup> A key advantage of this kind of surface is that they can be produced as flat and cold-formed glass surfaces and are also able to accommodate different forms of movements.

### Gaussian curvature

One can determine whether or not a surface is “developable” with the help of its Gaussian curvature. This curvature analysis employs mathematical geometric principles to analyse existing three-dimensional surfaces. Normal planes are defined by the normal vector of a point perpendicular to the surface. The intersection of the normal planes, with their respective normal vectors, and the surface geometries results in space curves.<sup>2</sup> The minimum and maximum curvature values of these space curves are obtained by analysing the other points on the surface and are referred to as the principal curvatures  $k_1$  and  $k_2$  of the surface. The Gaussian

curvature  $K$  is obtained by multiplying both principal curvatures using the applied equation and can have a positive, negative or neutral value (zero). For a surface to be developable, and thus be manufacturable or processed from cold-bent thin glass, it must have zero Gaussian curvature.

### Strengths of thin glass and bending radii

To determine the suitability of such surfaces for use in facades, one must consider both the strength as well as the flexibility of the glass. Values for minimum radii and maximum curvatures offer a first indication. From the characteristic values for strength, it is possible, using differential equations from

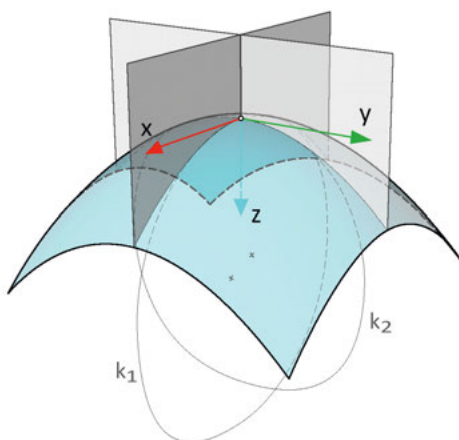

Gaussian curvature

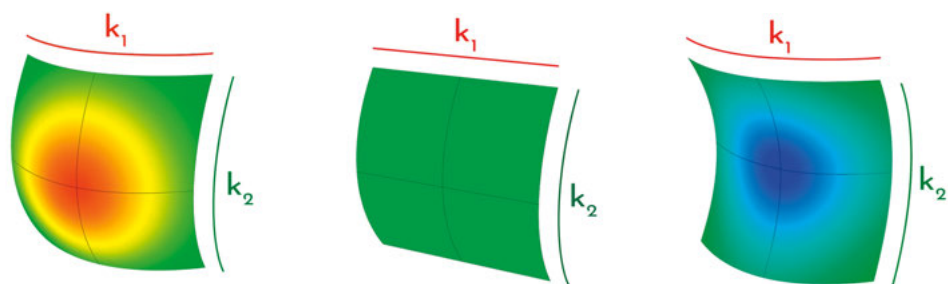

Kinds of Gaussian curvature



Science Tower in Graz by DI Markus Pernthaler Architekten

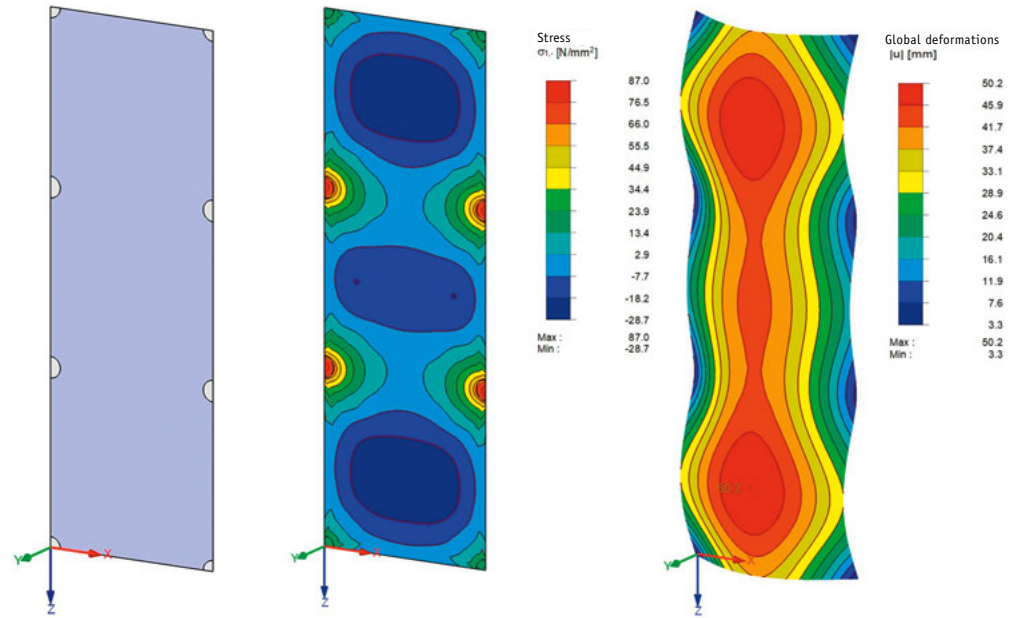

Finite element analysis of the thin glass elements of the Science Tower

bending-plate theory, to determine a minimum radius of curvature (or maximum curvature) as per the equation used. The accompanying table shows some typical values for the smallest bending radius as a function of glass thickness  $d$ , the modulus of elasticity of glass  $E$  and the characteristic values for strength  $f_k$  given in the standards.<sup>3</sup> When used for movable systems, one must also take into account a possible reduction in strength due to cyclic fatigue.<sup>4</sup> Thin glass panels can be tempered either thermally (by heating above the glass transition temperature  $T_g$ ) or chemically (by ion exchange below the glass transition temperature  $T_g$ ). Characteristic values for the higher strength properties<sup>5, 6, 7</sup> are given in the respective standards.

### Constructions made of thin glass

The high flexibility of thin glass makes it highly suitable for glass elements or facades made of cold-bent thin glass or laminated safety glass (LSG) that is pre-formed through lamination bending. In the case of movable facades, this high degree of flexibility opens up numerous new possibilities for effecting changes in size and position by bending glass elements instead of using hinges as part of a system of foldable rigid elements.

Another key advantage of thin glass is its favourable ecological footprint due to its reduced material requirements and secondary factors such as lower weight during transport. Facade assembly and erection are also simplified if the low self-weight of the individual glass elements obviates the need to use a crane.

Constructions using thin glass can be divided into rigid, movable and adaptive structures.

### Rigid structures

For rigid structures, a primary advantage of thin glass elements is their flexibility, which enables them to be cold-formed. Such glass panels retain their formed geometry throughout their lifetime. For multilayer thermal glazing panels made of multiple plates of glass with two or more intermediate chambers, the potential of thin glass for the internal layers has long been analysed and has now also been put into production. The resulting weight reduction has a number of advantages, e.g. for the design of window fixings and fittings. Cold-formed thin glass also presents further opportunities for use in curved thermal glazing as a product of its high flexibility and favourable behaviour in dissipating loads through membrane forces in the glass surface.

#### Science Tower

The Science Tower by SFL Engineering in Graz illustrates the high potential of thin glass. A laminated safety glass made of  $2 \times 2$  mm thermally prestressed thin glass was used for the outer skin of the first seven floors of the twin-skin facade. The glass panes on the higher floors are made of  $2 \times 3$  mm laminated safety glass to sustain the higher wind loads. The glass panes are fixed at their four corners or at four points along the long edges.

A qualitative finite element calculation carried out with a unit area load of  $q = 1.0 \text{ kN/m}^2$  for a wind

load of approximately  $w = 0.3 \text{ kN/m}^2$  acting on the outer skin showed that, although the requisite stress performance parameters are fulfilled, its deformation behaviour is not. Therefore, conventional procedures for calculating structural proofs and fitness will need to be revisited with respect to maximum permissible deformation. The possible reduction in strength due to cyclic fatigue must also be examined.

### Movable structures

In contrast to rigid structures, movable (as well as adaptive) thin glass systems are subject to permanent cyclic or occasional deformation. The following master's study projects demonstrate the enormous potential of the flexibility of thin glass.

#### Flower

This project draws inspiration from the carnivorous underwater plant *Aldrovanda vesiculosa* and the more well-known Venus fly trap *Dionaea muscipula*, which trap their prey inside a folding structure comprised of two lateral flaps hinged along a central rib. The flaps and central rib have a higher stiffness than the more flexible joint zones, which form an arced fold line. When the trigger is sprung, a change in turgor pressure causes the curvature of the central rib to change. The folding mechanism increases the curvature, causing the trap to close. After abstracting this principle and examining ways in which to realise it by technical means, a study of its parameters in an open and closed state was undertaken. When applied to facades, this principle can be used



Model of the Dancing Facade: a single system that incorporates deflection of the sun's rays as well as glare and solar protection

to create a wide variety of visual appearances through different patterns of open and closed flowers.

### Dancing Facade

An innovative thin glass facade concept devised for an urban high-rise in the metropolitan context of Manhattan allows natural light to be directed deep into the interior and provides conventional glare and sun protection functions in a single system. Reflections off the glass surface deflect daylight into the interior to produce a diffuse lighting situation. The "dancing" facade modules can be freely adjusted to maximise the amount of sunlight entering the building over the course of the day. The facade's appearance therefore varies in response to the needs of the users and daylight requirement. The movement mechanism and facade geometry were explored using a 1:1 model. Natural measurements were recorded using the Proliner system from Prodim, which creates a 3D geometry of the surfaces using a very large number of measuring points. Vertical and horizontal sections through the surfaces were then derived using a CAD system and served as a basis, along with the resulting bending radii, for validating the results of the FE calculations.

### Chameleon Facade

The "Chameleon Facade" exploits the specific properties of bimetal strips. A bimetal strip consists of two metals with different coefficients of thermal expansion that are bonded to each other. The different metals expand at different rates under heat, causing the bimetal strip to bend in one direction. A 40 × 40 cm large, cylindrically curved laminated thin glass pane with an overall thickness of about 2 mm has 1 cm wide bimetal strips firmly bonded to the edges of its outer face. Three corners of the glass pane are firmly anchored to the substructure, making them rigid. The fourth corner is held at a distance from the substructure by means of a spacer and can move freely in an outward direction. As the bimetal strips warm up under the heat of the sun, they begin to bend causing the glass pane to bend with it so that the surface of the facade opens. This mechanism can, for example, be used to autonomously ventilate an interior without needing an energy supply. A further feature of this facade is a thermochromic heat-responsive film sandwiched between two panes of glass. As the temperature rises with increasing solar radiation, the film becomes opaque, reducing light incidence.

The principle is similar to that of electrochromic films, but requires no electricity and is therefore autonomous.

### Adaptive structures

Adaptivity in the context of thin glass refers to the ability of a facade to react, through responsive controls or autonomously, to external influences. Changes to the surface geometry can be effected using actuators. To control and regulate the actuators, a sensor system is required to measure ambient influences on the system. The measurements serve as input for a control system that regulates the behaviour of the actuators to produce the desired response for the prevailing conditions.<sup>8</sup> Alongside such control systems, there are also systems that respond entirely autonomously, as seen in the Chameleon Facade described earlier. Sensors in the form of thermometers, hygrometers or pyranometers measure environmental influences such as temperature, humidity or solar radiation, and convert these into electrical impulses. These serve as input for control systems that in turn generate the control signals for the actuators. Actuators are usually electric motors or electromagnetic valves used in motor

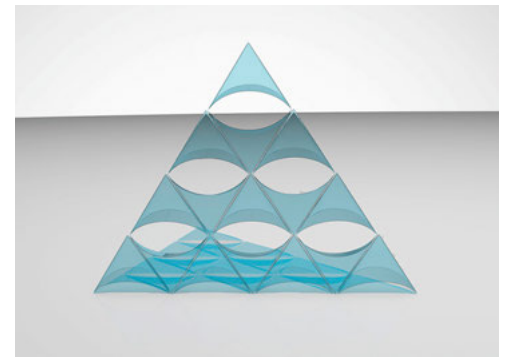
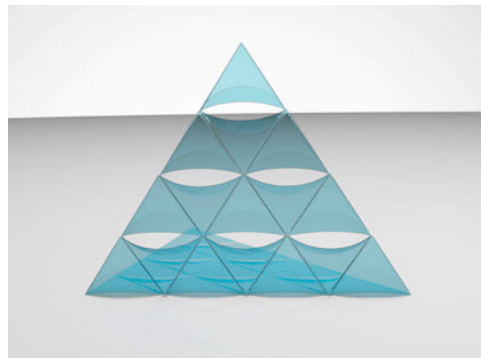
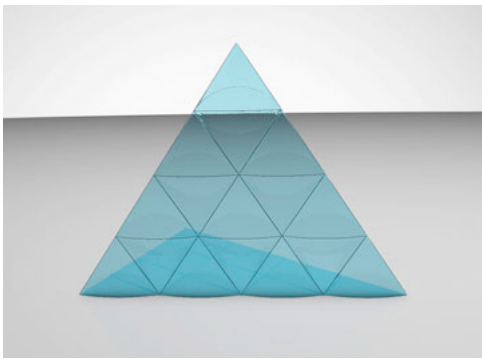

Movement principle of the Dancing Facade

control and comfort systems. They convert the signals of the control system into an action.

#### Controlled actuators

An impulse detected by a sensor marks the beginning of the process chain in a controlled system. This is converted into a command that is forwarded to the actuator, which then triggers a movement. For example, electrolinear actuators convert electrical energy into linear motion.

#### Autonomous actuators

Intelligent or “smart” materials have properties that enable them to perform the control process themselves without the need for additional technology. “Semi-smart” materials can perform changes once or several times, while “smart” materials have permanently reversible properties. The changes in material property are triggered by physical influences such as temperature, humidity, light, pressure, electrical, magnetic or chemical impulses.<sup>9</sup> Thermobimetal actuators are thermally active components that change shape continually with temperature, producing continuously changing movement. A special subcategory of bimetals alongside bimetal strips or coils, are thermal snap-action discs or switches which change state discontinuously as a product of their geometry.

#### Bi-Wood actuators

While thermal bimetals respond to changes in temperature, humidity-active elements change shape in

response to changes in humidity. Bi-Wood actuators take advantage of the moisture-sensitive behaviour of wood. In wood, this moisture deformation is called swelling and shrinkage. By using two wood elements with different swelling characteristics, an actuator can be created that draws on mechanisms found in nature and responds to natural processes.<sup>10</sup>

#### Outlook

The principles of building physics describe the interface between the outside environment and the interior and highlight the importance of the facade in controlling the flow of energy and energy consumption of buildings. Adaptive or movable facade elements enable one to positively control the comfort levels inside a building. The advent of thin glass with thicknesses of between 0.5 mm and 2 mm has opened up a completely new field of applications that looks set to transform the design of building envelopes.

- 1 Schumacher, M.; Schaeffer, O.; Vogt, M.: *MOVE: Architecture in Motion – Dynamic Components and Elements*, Basel, 2010.
- 2 Neugebauer, J.; Lehner, T.; Baumgartner, M.; Wallner-Novak, M.; Wrulich, Ch.: “Adaptive and Moveable Structures Made from Thin Glass”, in FCA International (ed.): *GlassConGlobal Conference Proceedings. Innovation in glass technology*, Chicago, September 2018.
- 3 Ibid.
- 4 Hilcken, J.: *Zyklische Ermüdung von thermisch entspanntem und thermisch vorgespanntem Kalk-Natron-Silikatglas*, Heidelberg, 2015.
- 5 “Floatglas  $f_k = 45 \text{ N/mm}^2$ , TVG  $f_k = 70 \text{ N/mm}^2$ , ESG  $f_k = 120 \text{ N/mm}^2$ ”; “ÖNORM B 3716-1: Glas im Bauwesen – Konstruktiver Glasbau, Teil 1: Grundlagen; 2012.”
- 6 “CVG – chemisch vorgespanntes Glas –  $f_k = 150 \text{ N/mm}^2$ ”; “EN 12337-1: Glas im Bauwesen – Chemisch vorgespanntes Kalknatronglas – Teil 1: Definition und Beschreibung.”
- 7 Neugebauer, J.; Lehner, T.; Baumgartner, M.; Wallner-Novak, M.; Wrulich, Ch.: “Adaptive and Moveable Structures Made from Thin Glass.”
- 8 Institute for Structural Mechanics, University of Stuttgart, <https://www.ibb.uni-stuttgart.de/forschung/nichtlinear-und-adaptiv/Institut>.
- 9 Schumacher, M.; Schaeffer, O.; Vogt, M.: *MOVE: Architecture in Motion – Dynamic Components and Elements*.
- 10 Poppinga, S.; Zollfrank, C.; Prucker, O.; Rühle, J.; Menges, A.; Cheng, T.; Speck, T.: “Toward a New Generation of Smart Biomimetic Actuators for Architecture”, *Advanced Materials*, 19 (30), 2018.

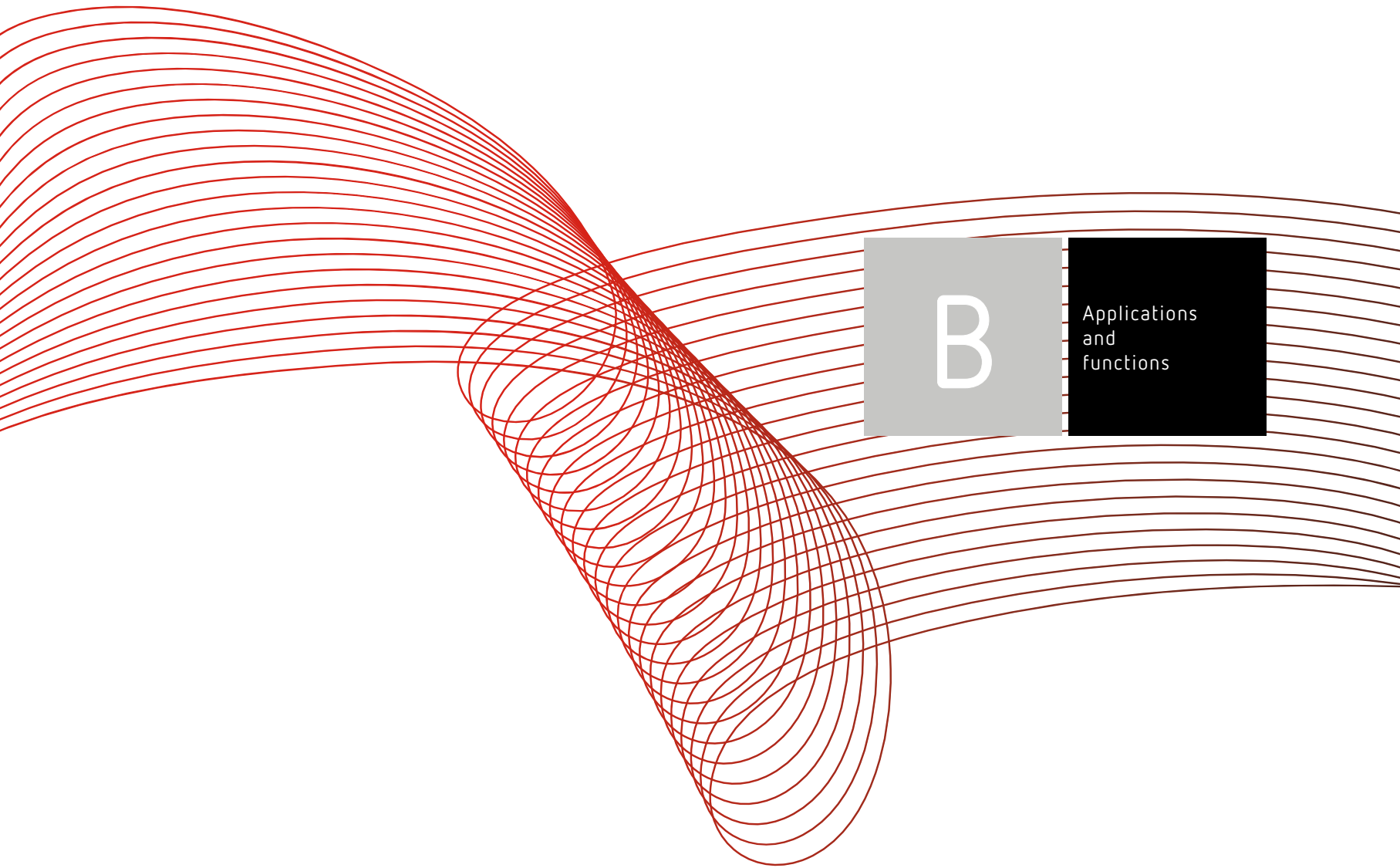

B

Applications  
and  
functions

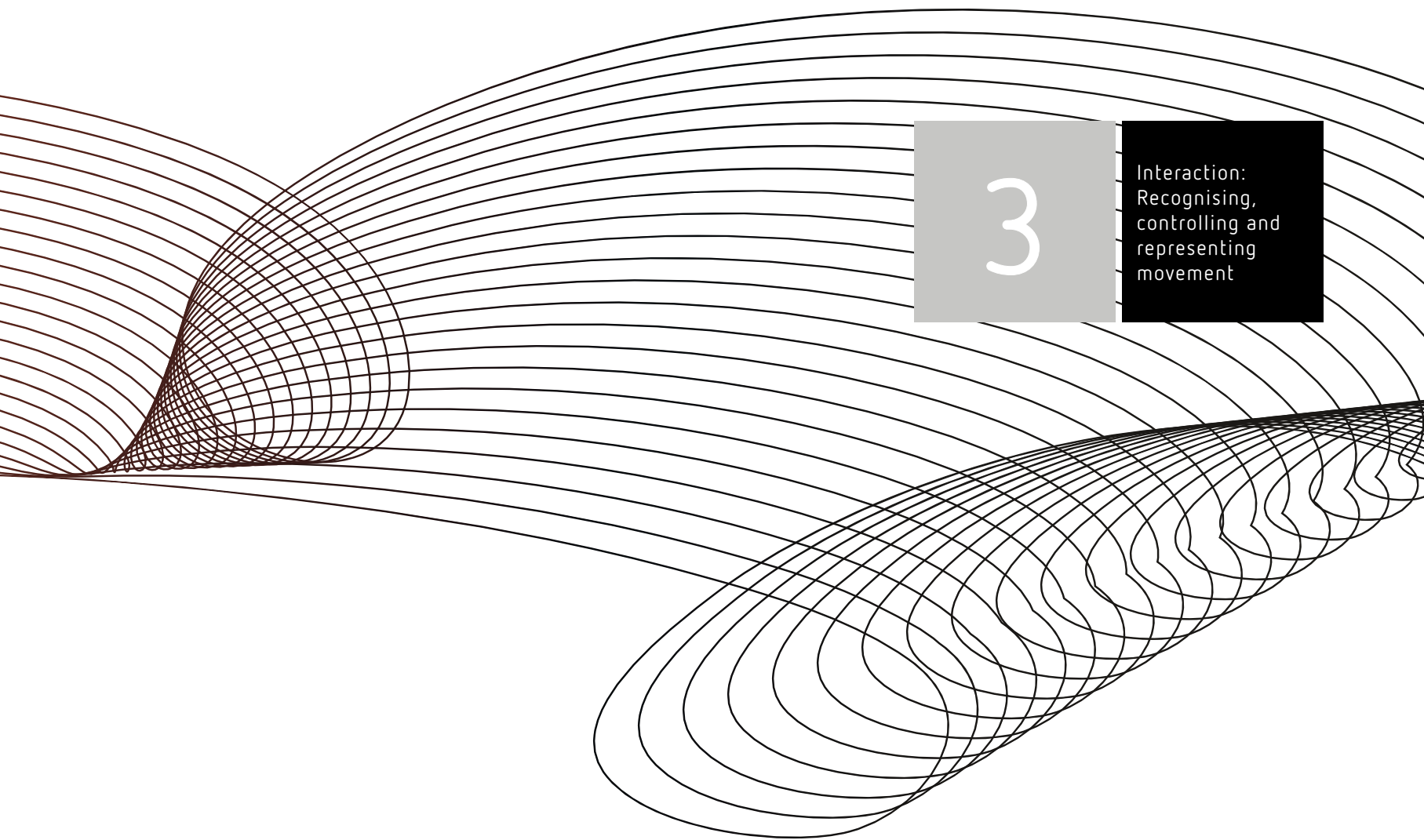

3

Interaction:  
Recognising,  
controlling and  
representing  
movement

### ■ 3.1 Dynamic design with light: Media facades

Thomas Schielke

Compared with mechanically moving parts, software-controlled light pixels offer designers a fascinating degree of freedom to give architecture a sense of dynamism in ever new variants without requiring significant construction works.

The multitude of images with which many media facades clamour for attention in the urban realm recalls the endless stream of images of social media, in which people satisfy their need for self-expression. These buildings convey the attitude that static architecture alone no longer suffices to demonstrate one's standing in the modern city; move-

ment is now mandatory. The pursuit of new means of expression is motivated both by a desire to demonstrate quantitative capability as well as qualitative design possibilities, such as the Shanghai Tower, whose dynamic light patterns along the more than 600m high building do all they can to stand out as modern in the colourfully illuminated skyline. The qualitative debate, on the other hand, is much more complex because aesthetic, communicative and technical dimensions afford a wide variety of possibilities and combinations. Digitalisation opens up a wide range of options for producing movement

on facades using light and at the same time of imbuing it with architectural quality. In Asia, where in cities such as Shenzhen or Hangzhou many skyscrapers are synchronised with one another, light can set the urban space in motion, giving the city an urban expression.

#### **The aesthetics of dynamics**

The nocturnal narratives of media facades with their changing light patterns and coloured light present a competing vision of beauty in the digital age alongside the glass buildings of modernity with

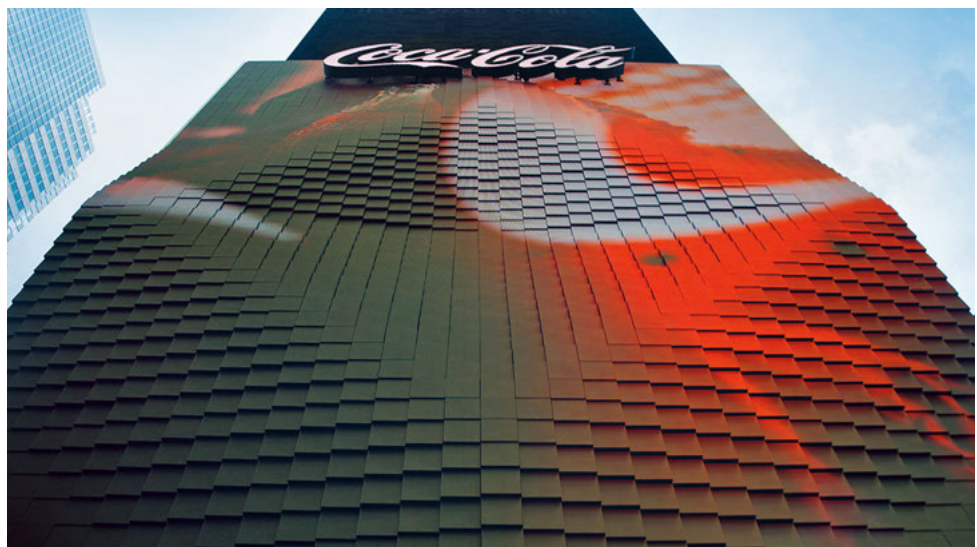

Times Square in New York has seen numerous examples of innovative illuminated advertising over the years. These individually movable LED-cubes add a dynamic spatial component to the illuminated media facade.

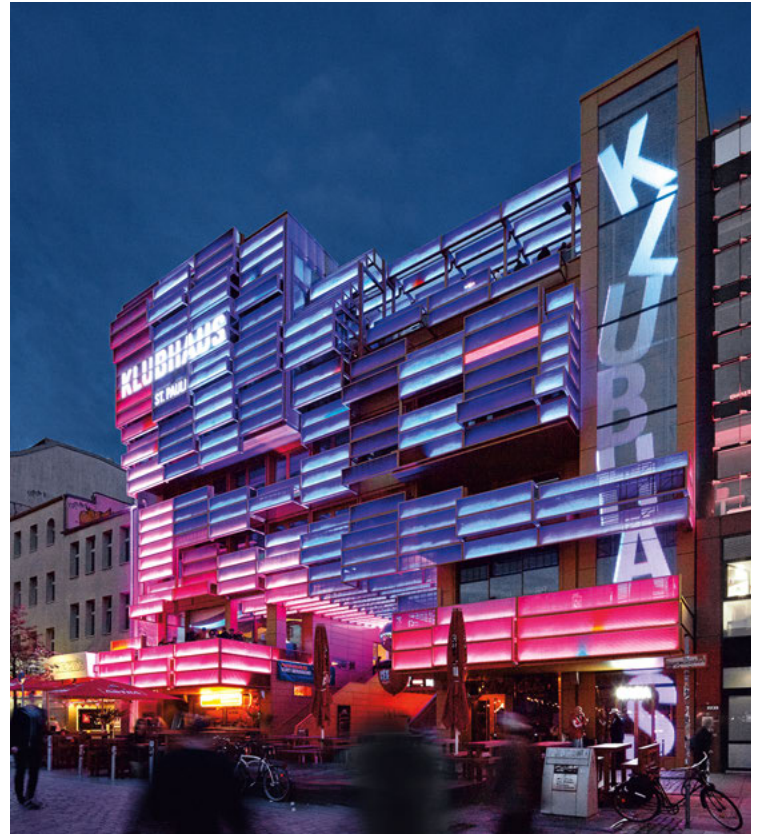

Dynamic illuminated displays for art, advertising and the building's own signage on Klubhaus St. Pauli in Hamburg create a striking impression day and night. The movement of the lift is part of the display.

their smooth, reflective facades. Software-controlled light pixels on surfaces have given rise to a renaissance of baroque opulence and translated the polyperspective of cubism into dynamics. This diverse imagery calls the static character of architecture into question. In the context of such fast-moving, colourful scenographies, terms such as longevity and sustainability seem out of place. For the champions of the night sky, too – the advocates of the so-called Dark Sky – such rampant light emissions are harmful for people and the environment; they require strict measures to regulate their use and protect the night.

#### Light as a medium of communication

For building owners, the appeal of media facades lies in their motion, their difference to other conventional facades in the vicinity and in their ability to communicate different messages. One of the primary motives for storytelling with light is to make a clear mark on the urban surroundings. As such, the design and the content of media facades also contribute to the brand message. However, context

is everything in brand communications: locations and cultural environments that accord great value to regional architectural references will perceive technoid media facades as a gaudy intrusion into local harmony. The fact that media facades are generally quite bright also raises the question of whether neighbours should be able to have a say in the matter so that they are not subjected to unending brand exposure in their bedroom or living areas. Asian metropolises, however, show that glittering reflections and spectacular colour sequences do not necessarily have to be tacky or lack professionalism.

#### LED technology

The advent of LEDs and the miniaturisation of the light source triggered a wave of dynamic development in media facades. Their small format makes them easily integratable into facade elements and at the same time they have a very long service life. The additive colour mixing of RGB technology allows for a large number of colours that can also be easily changed. This freedom of design goes hand in hand with considerably lower technical demands

and much higher energy efficiency compared with conventional light sources. The enthusiasm for this new technology has inevitably led to some emphatically colourful solutions that, however, lack a correspondingly ambitious colour design concept. A long-term curatorial concept is just as important as the technical and design component when planning media facades.

#### Visualising data streams with light

The integration of sensors has given rise to fascinating opportunities for creating interactive facade elements that react to their environment. By combining control and design software with the hardware of LED chips, it is possible to use LED elements like computer pixels on a screen. All manner of input signals – images, sounds, weather information, data from social media or computer games, and even brain waves – can be processed automatically via algorithms and transformed into a light performance. The spectrum of possibilities for storytelling via building facades ranges from dynamic installations with entirely preprogrammed stories



Airborne pixels made using a combination of drones, coloured LEDs and a light control

and patterns and responsive facades with local input signals in which sensor technology changes the output, to interactive projects in which citizens actively enter information via sensors, mobile devices or other interfaces.

Toyo Ito's Tower of Winds (1986) is one of the first such dynamic lighting projects: it responds to the wind and street noise parameters of the environment to generate motion using light. The lighting concept registers changes in the urban townscape ranging from the constant urban street lighting to the changing images of illuminated signs. Companies were quick to take up the concept of responsive media facades in order to attract customers with moving imagery in shopping centres such as the Zeilgalerie (1992) in Frankfurt by Kramm & Strigl and Christian Möller.

With the increasing possibilities of large, high-resolution outdoor screens, designers have been looking for new ways to combine the aesthetic possibilities of media facades with eye-catching video displays. Convincing solutions involving low image resolution may skillfully counterbalance advertisers' high-resolution commercials. Realities:united came up with an intriguing variant in this vein with an installation for Wilkie Edge (2008) in Singapore that enhances the surrounding commercial billboard content with a low-resolution, dynamic visual echo.

#### **The art of the pixel: Dots, lines, areas and volumes**

The arrival of pixels on facades as a decorative design element prompted a discourse on the aesthetics of pixels: how does one's perception of a pixel

change when approaching a building? What shape and dimensionality should or can a pixel have?

Since we can only win the race of pushing forward the boundaries with the most modern technology until the next new media facade goes into operation, other solutions were explored that deliberately evade this competition. The media facade of the Kunsthaus Graz (2003), for example, deliberately uses a retro design with round fluorescent lamps instead of small LEDs. The way a light pattern changes as one approaches a building can be controlled through the size and spacing of the pixels. From a distance, the "SPOTS" installation (2005) by realities:united at Potsdamer Platz in Berlin looks like a moving image but from up close one can clearly see the two layers of coloured semi-transparent film and the three-dimensional shapes of the fluorescent light sources.

To avoid competing with the smooth perfection of high-resolution smartphone or television screens, several designs have explored pixels with a three-dimensional quality. The light frieze on the new extension to the Kunstmuseum Basel (2016) illuminates the horizontal brick coursing of the masonry to subtly alter the visual appearance of the brick facade. At Hanjie Wanda Plaza (2013) in Wuhan, China, on the other hand, the pixels are spherical and of different sizes, and can radiate light both forwards and backwards. Through the combination of stainless steel and patterned glass, the shopping centre acquires a glittering and reflective surface. The size and versatility of the pixels at the Centro de Creación Contemporánea de Andalucía (C3A, 2013) is even greater, and their crystalline shape

gives them a strong sense of three-dimensionality, despite the shallow depth of the construction.

While media facades are often less attractive during the day than in the evening, the sunlight on the C3A, for example, creates a varied play of shadows on the modulated facade. Even though the geometry of the pixels is static, their changing illumination still creates movement on the facade.

Kinetic installations with LED pixels such as the "Brilliant Cube" (2013) at Gangnam Station in Seoul, the "Spaxel" project of Ars Electronica with 100 luminous drones above Linz (2016) or commercial installations such as Coca-Cola's advertising space at Times Square in New York (2017) suggest that media productions in urban space are increasingly focusing on movement. The position and shape of the pixels are also in motion. Such comprehensive concepts, in which both light and pixels change dynamically, are increasingly liberating themselves from conventional static architecture, allowing movement to take centre stage.

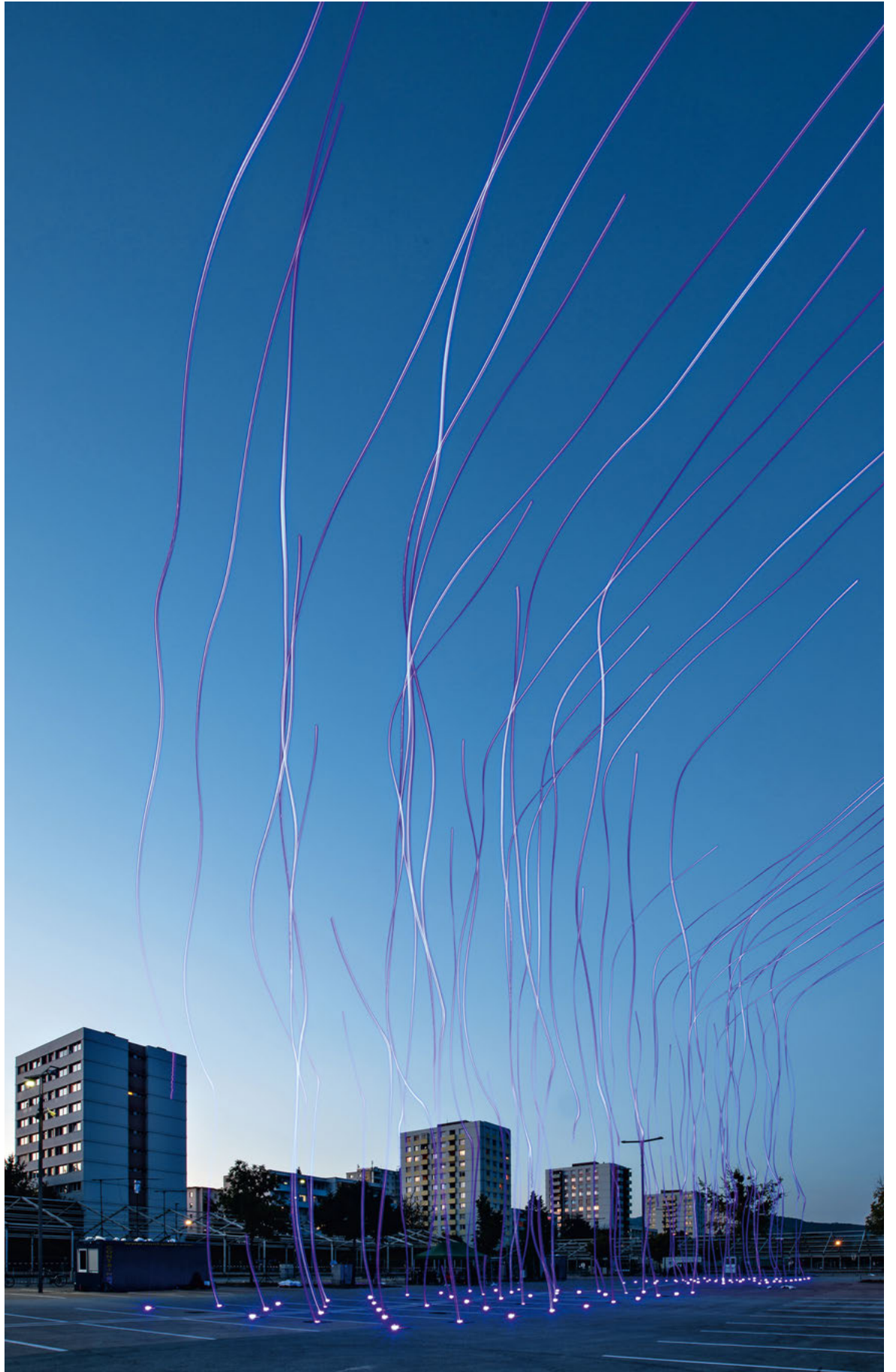

Using choreographies of luminous drones, media facades can take flight, opening up a whole new field of possibilities for airborne illuminations.

### ■ 3.2 4dTEX

Claudia Lüling, Johanna Beuscher



Pleated 3D textiles: hingeless opening mechanism with transparency control at the macro and meso levels

Three-dimensional, multilayer textiles offer new constructive-aesthetic possibilities as a result of their specific geometry and adjustable material thicknesses. In particular, in combination with movement mechanisms, they present new ways of modulating light with low energy input. Movement and the time of movement become the fourth dimension of textile design.

#### Textile material

In his "family tree of materials"<sup>1</sup> from 1995, Gerd Auer distinguished between organic and inorganic materials. Beginning with the materials of the primeval hut and their further development through forming processes such as cutting, hewing and

pressing; chemo-physical transformations such as crushing, melting, firing or casting; synthesising methods such as condensing, polymerising or carbonising; all the way up to hybrids and heteroses such as cross-linking, alloying or laminating, this compilation remains as relevant as ever. In the meantime, Auer's predicted prospect of nanotechnological production has become reality. Textiles also appear in this overview, though they are mentioned only once and under the aspect of hybrids as "mixed textiles". They come after wool and mineral fibres, which like other fibre materials define the actual materiality of textile structures. The reason is that textile itself cannot really be described as a material.

"Textiles" are the joining techniques that give these linear materials their actual form through often age-old techniques such as knitting, fulling, weaving, laying, braiding, felting and knotting. Using these techniques to combine different fibre materials is therefore the basis for developing optimised composite material structures, which became known as hybrids in the 1990s and were much vaunted as a forward-looking development.

#### Technical textiles: Three-dimensional

What we call technical textiles are found not only in aviation, the automotive sector, medicine or environmental protection. In architecture, textile reinforcements are used widely in monolithic con-



Varying transparency of a 3D textile by shifting the deck layers parallel to each other



Varying transparency of a 3D textile by stretching the deck layers perpendicular to each other



Varying transparency of a 3D textile by bending and compressing the deck layer

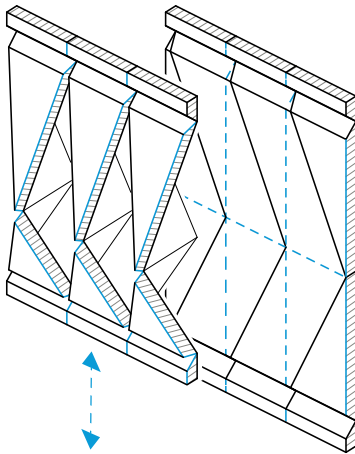

Folding and flaps at the meso level:  
a pleated 3D textile with precreased folds  
and precut incisions

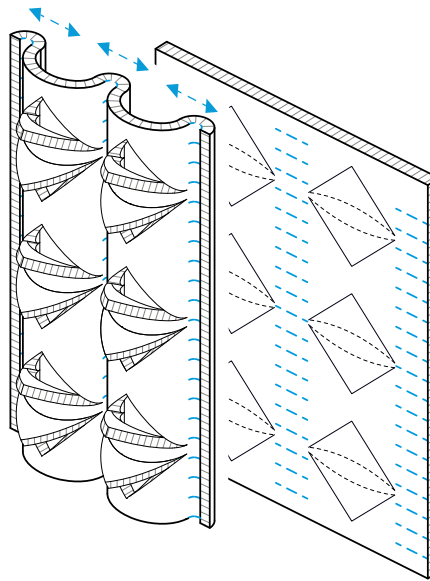

Bending and flaps at the meso level: torsional flexural buckling ("Flectofold")<sup>3</sup> applied to 3D textiles

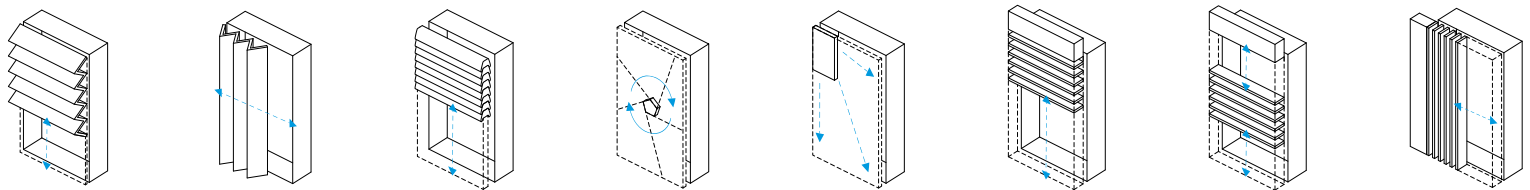
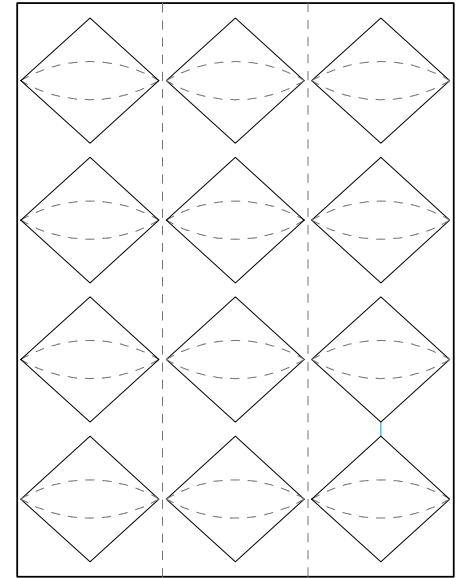

Macro level: different movement variants for planar, folded and gathered solar shading elements made of 3D textiles

struction, high-tech fibres have revolutionised lightweight construction, and fibre-based materials are used for insulation and sunshading systems. The Frankfurt Research Institute FFin and the Textile Lightweight Construction Group at Frankfurt University of Applied Sciences have conducted research in this field for many years, in particular into textile multilayer structures and dynamic building components made of "spacer fabrics". These can currently be produced in material thicknesses of up to 200 mm, depending on the spacer distance, using materials such as polyester and polyamide, or high-tech fibres such as carbon, glass and basalt fibres.

#### Spacer fabrics and solar protection: Four-dimensional textiles

The properties of spacer fabrics can be adapted to meet different requirements. Their damping properties are already used in mattresses, upholstery, sports shoes and filter systems. Their application as movable elements, especially in the context of solar protection, are currently being investigated for the first time at FFin.<sup>2</sup> Research has focused on the question of the extent to which the special textile structure of spacer fabrics allows defined transparencies to be produced for specific angles of incident light. A further aspect is research into movement mechanisms for opening and closing and for con-

trolling transparency and incidence of light with the aim of developing robust and low-maintenance facade components. When closed, they can also temporarily reduce both heat loss from and heat gain in the rooms behind them. Based on the principles of traditional solar protection systems such as shutters, jalousies and pleated blinds, FFin is investigating how spacer fabrics can be used at the macro level of the entire element to produce controllable daylight management systems. At the same time, movements at the meso level, i.e. within the textile structure of the spacer fabrics themselves are being investigated.



Curved and compressed 3D textiles with transparency control at the macro and meso levels

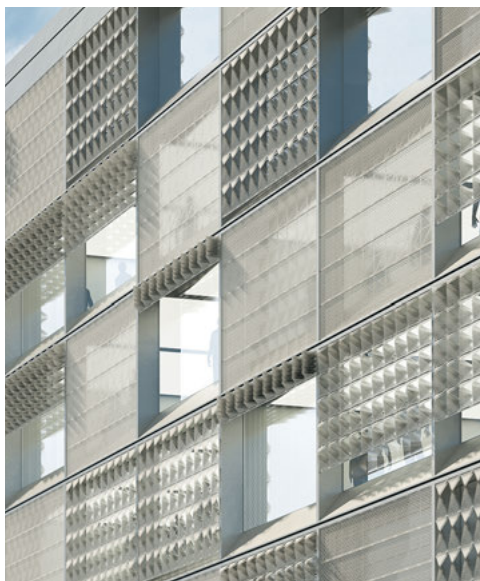

Folded and cut 3D textiles with transparency control at the macro and meso levels

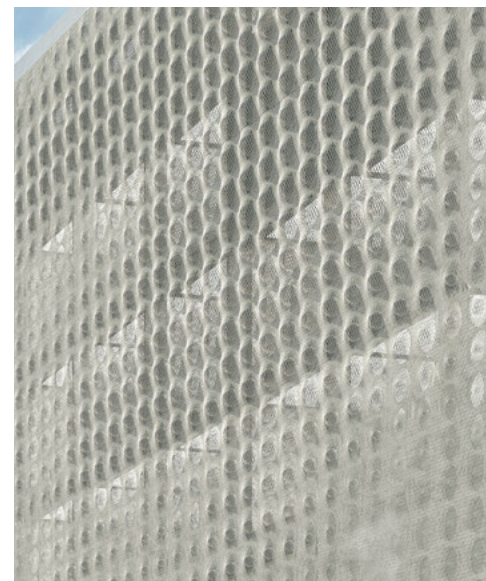

Transparency and visibility modulated at the meso level by stretching the deck layer of a 3D textile at particular points

### Dynamic movement mechanisms: Folding and bending

Traditional textiles are pliable, flexible, movable semi-finished products, which can change size or move with respect to their surface plane, for example through reversible folding and unfolding, gathering, crimping or soft-folding, i.e. bending. At the same time, they can also be stabilised by folding, impregnating, filling and similar means. For the movement mechanisms of spacer fabrics, there are number of special options: at a laboratory scale, multilayer spacer fabrics can already be developed and finished for industrial production such that different thicknesses can be achieved by programming varying distances between the textile layers. Fabrics can have alternating sections of stiff and thick or flexible and thin material. As such, the textiles can be folded up as a whole (at the macro scale) while exhibiting a specific basic transparency through the use of different density cover layers (at the meso scale).

Alongside this simple folding mechanism, where each folding section has no set folding direction and can function equally as a peak or valley fold, it is also possible to achieve folding structures with a defined folding direction by making alternating partial incisions in the spacer fabric without penetrating the deck layer opposite the incision. Many of the folding, vertical-folding and pleating mechanisms developed by FFin have since been patented.

The resulting forms are aesthetically pleasing and recall sandwich structures, but have the added advantage of varying translucency, changing material thickness and partly rounded edges. While partial incisions can also be used to create hingeless joints, full incisions in the textile structure can be used to create transparent openings for views in and out. Ingenious pleated structures have been developed that can be used as external solar protection. Where necessary, the stability of these fabrics can be increased using special coatings and partial filling. In an attempt to avoid open edges or incisions, and thus to make more robust, low-maintenance elements, bending mechanisms have also been investigated. The movable elements developed so far are softer in appearance than the folding structures. At the meso scale, the bending of a spacer fabric results in the pressing together or compression of the texture of the inner surface layer, so that controlled bending allows for areas of lower translucency. Such elements can also be mounted on the outside of facades and act like a thick, stable, translucent curtain.

### Dynamic movement mechanisms: Stretching and compressing

Alongside folding or bending, stretching and compressing are further methods by which the elasticity and stretching behaviour of textiles can be utilised to control light transmission. Experimental investi-

gations into these mechanisms using these principles again reveal the great potential of spacer fabrics. The surfaces of spacer fabrics are held apart at a given distance by pile yarns, the frequency and arrangement of which is programmable, as is the structure of the deck layers. Accordingly, deck layers with sections of different densities can be shifted in relation to one another, allowing the incidence of light to be controlled through movement. This concept has likewise been patented.

Spacer fabrics can also be made stretchable by using either knit or mesh-based base fabric, which is inherently elastic, or by producing base fabrics with a share of elastic fibres. As with bending, here too, movement changes the degree of translucency. By tensioning the fabric in the surface axis, the textile stretches and becomes more translucent. Alternatively, the spacer fabric can be prepared by making incisions opposite each other in the deck layers so that the stretchability and transparency of the fabric results from pulling apart the deck layers, which are then only held together by the pile threads. It is also possible to stretch individual sections of the textile perpendicular to the surface by omitting the pile threads, or to stretch individual, linear zones of deck layers on both sides by bulging. This results in zones of gill-like openings with an organic appearance, which allow one to see through the fabric. These mechanisms have also been patented.

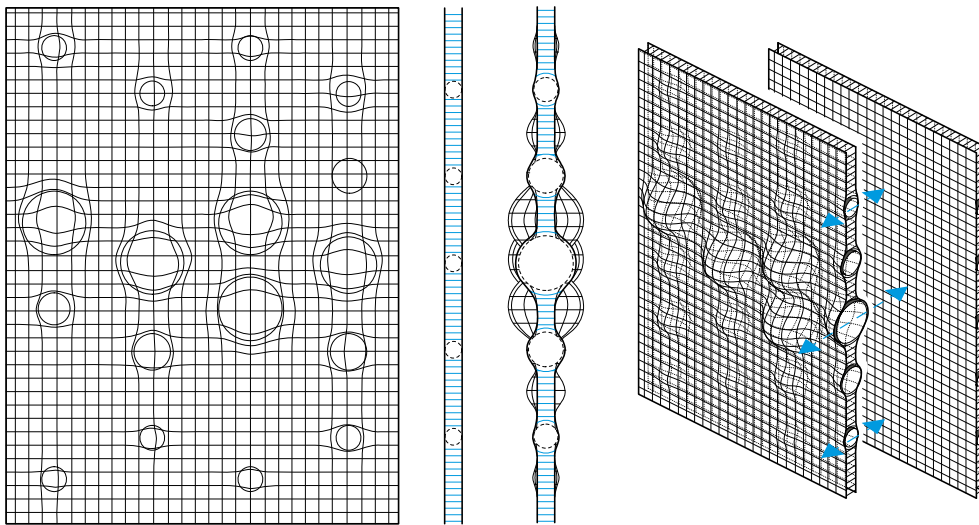

Bending and compressing 3D textiles at the meso level with variable transparency control

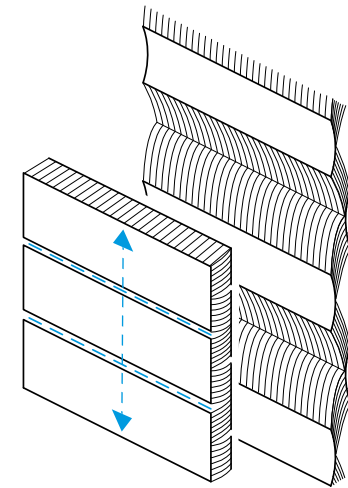

Stretching at the meso level: 3D textiles with alternating incisions on the deck layers. Transparency is achieved by pulling apart the deck layers.

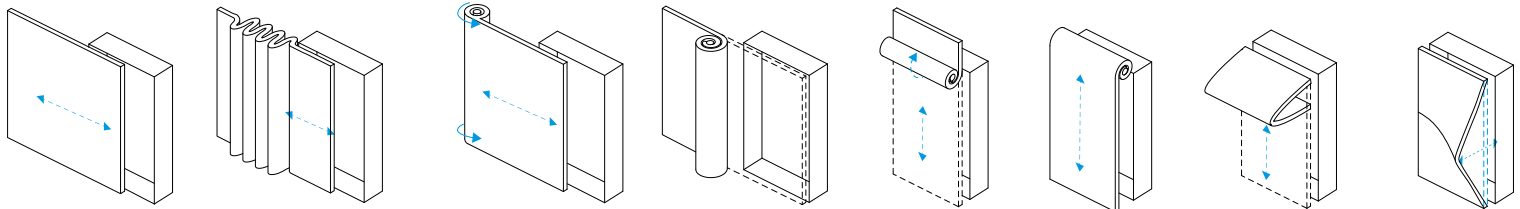

Macro level: different movement variants for planar, extensible and bendable solar shading elements made of 3D textiles

### Folding, bending, stretching, compressing: Triggering options and added functionality

The geometries and material thicknesses of spacer fabrics, as well as the design of their inner textile structures, can be used to produce different kinds of semi-finished products with dynamic options. They support different forms of movement, both across their surface and within their inner textile structure. Both are aesthetically appealing, functional and present versatile and varied means of controlling daylight incidence, heat gain, and views in and out. The forces required to trigger these movements can be of varying nature. For pleated or bending surfaces as well as for stretching or compressing movements, manual, electric, magnetic or pneumatic drive systems are conceivable. Adaptive fibres, coatings or fill materials based on shape

memory alloys (SMAs) or shape memory polymers (SMPs) can also be used to trigger movements in response to changes in temperature, light or heat. At FFin, investigations are currently being conducted into ways of exploiting the alternating properties of SMAs or SMPs, using materials with either two-way properties or one-way properties in combination with elastic textiles as a reset mechanism.

Further optimisations include the improvement of qualities such as the natural insulating properties of spacer fabrics. Added functionality can also be incorporated into the microstructure of the textile: light and heat conduction, water transport, filter functions or sensor properties can be incorporated using special fibres with light-conducting, hydrophilic or current-conducting components.

- 1 Auer, G., "Stammbaum der Werkstoffe", *Daedalos*, 56, 1995.
- 2 "Reversibel faltbare, energetisch wirksame 3D-Textilien im Baubereich" (ReFaTex), *Förderlinie Innovationsfonds Forschung Hessen (IFOF)*, Team members: M. A. Johanna Beuscher, Dipl.-Ing. Natalija Miodragovic.
- 3 Flectofold: jointless facade shading device inspired by the underwater snap-trap of the waterwheel plant, joint research project at the Universities of Stuttgart, Freiburg and Tübingen (Transregio 141)

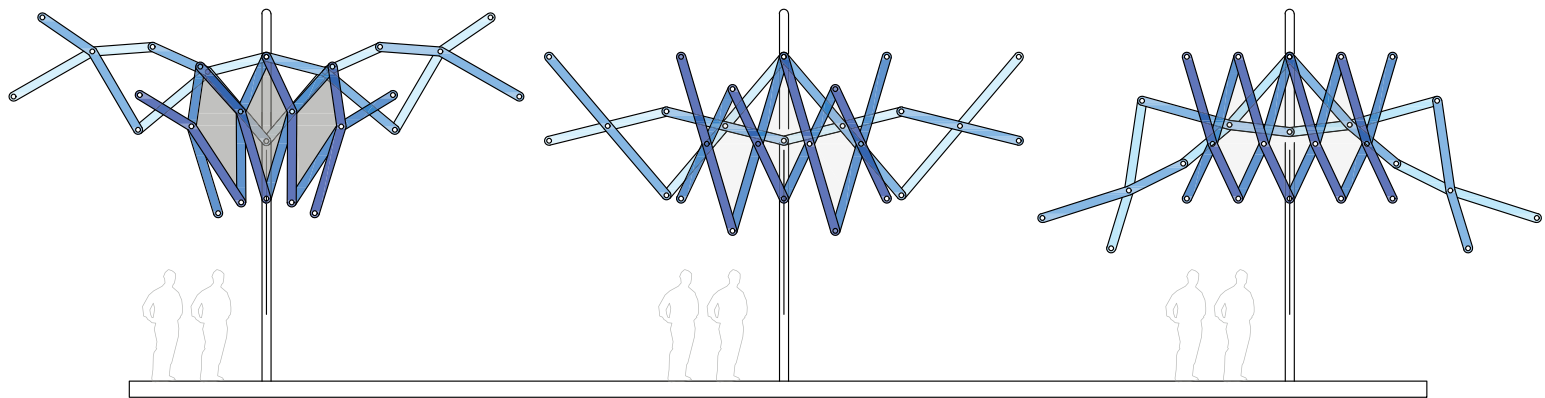

Scissor linkages of the same loop type (kite) resulting in different movements

### ■ 3.3 Scissor linkages in the design of adaptive morphologies

Yenal Akgün, Feray Maden, Şebnem Gür, Gökhan Kiper, Koray Korkmaz, Engin Aktaş, Müjde Yar Uncu

In all periods of history, humans have tried to construct flexible buildings that are capable of adapting to ever-changing requirements and environmental conditions. In response to changing circumstances, they have proposed new solutions by incorporating movement into architecture. Thus, the concept of movement is not new to architecture. Indeed, the roots of the idea of capturing movement within a structure date back to ancient times. Simple nomadic tents built with flexible outer skins can be seen as the first example of adaptive structures used for protection against environmental extremes.<sup>1</sup> The canvas sheets used for covering the roof of the Roman Coliseum, as another example, formed awnings to provide not only protection from the sun but also a breeze for the audience as it sloped down towards the centre to catch the wind.<sup>2</sup>

Adaptive roofs were used in demountable theatres as a protection against sun and rain in medieval times, even though the covering area was no larger than a few square metres. The concept of movement in architecture continued to play a significant role during the Renaissance. In the 18th century, awning constructions became widespread in Europe. In the 19th century, new design solutions and new technologies were introduced into architecture with the Industrial Revolution. New building materials such as cast iron, steel and glass offered the possibility and freedom to design new buildings and structures of a size, form and function unimaginable before.<sup>3</sup> In the 20th century, technology became an increasingly important factor in enabling transformation and innovation in architecture and opened up new

dimensions for adaptive forms of construction. The developments in architectural computing and material science have also facilitated the applications of adaptive/expandable structures. The growing relevance of these structures due to their advantages compared to conventional structures led to the development of different types of adaptive structures. Expandable structures comprise both a compact and a deployed form, usually comprising assemblies of rigid bodies connected by joints. They allow geometric transformations in order to satisfy practical requirements. As these structures are able to change their shapes from one configuration to another numerous times, they require dealing with kinematics (a sub-branch of mechanics) in addition to architectural and structural design. The complexity of design, construction and engineering processes for adaptive/expandable structures necessitates an interdisciplinary design methodology with novel design approaches, theoretical principles and analytical methodologies.

#### Scissor linkages: Applications in architecture

Scissor linkages are one of the most common types of adaptive/expandable structures. Since the Greek and Roman periods, these structures have been used in various applications in architecture and engineering as expandable roof structures, for shells and in furniture design. Scissor linkages are popular because they comprise very basic motion principles and can create both planar, beam-like expandable structures and expandable spatial shells with various geometries.

Compared to other types of adaptive structures (plate structures, strut-cable structures and membrane structures), scissor linkages are based on a simple system composed of scissor elements. To form a basic primary scissor unit, two rigid bars are connected to each other at an intermediate point through a pivotal connection that allows them to rotate freely about an axis perpendicular to their common plane. Planar and spatial expandable structures with different geometric shapes can be created by connecting multiple scissors to each other at their end nodes. A number of geometric principles and conditions of deployability must be provided to generate adaptive structures. A look at design methods described in existing literature provides an understanding of those principles and conditions, and forms the basis for two newly developed design methods with applications of scissor linkages.

#### Design methods

There are two basic methodologies for the design of expandable scissor linkages: the unit-based method and the loop assembly method. These methods utilise different approaches and have different advantages. Both are applicable for planar scissor beams and shells.

##### 1. Unit-based method

The unit-based method allows the generation of an expandable scissor linkage by the serial multiplication of one of the scissor unit types. The scissor linkage is obtained by connecting the “primary

a. Translational scissor unit

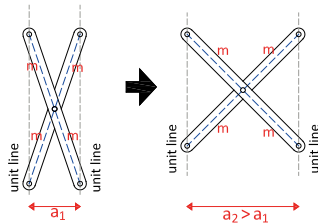

b. Polar scissor unit

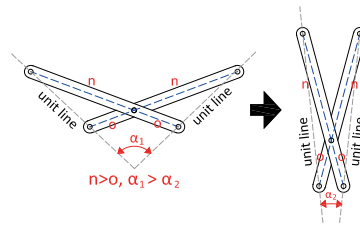

c. Angulated scissor unit

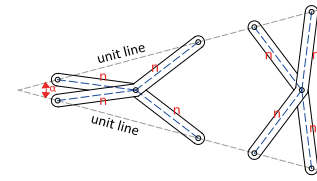

Translational planar scissor linkage

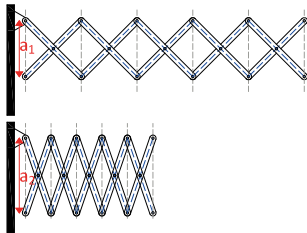

Polar planar scissor linkage

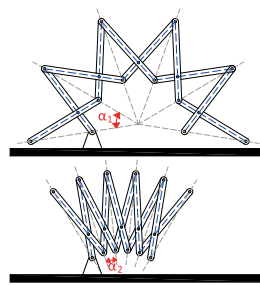

Planar scissor linkage with angulated scissor unit

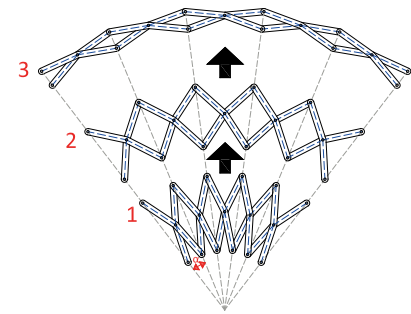

Common primary planar scissor units and their deployment

units” to each other through the terminal joints. The scissor linkages can be generated by multiplying one of the primary units or by a serial assembly of several sublinkages produced using a number of primary units. Various scissor linkages with different curvatures can be obtained in this way. This method is based on the geometric characteristics of the primary scissor units. All types of primary scissor units use an imaginary line, the “unit line”, between the corresponding upper and bottom ends of the bars. In the case where the unit lines remain parallel to each other during the deployment process, a “translational scissor unit” is obtained. A

“polar scissor unit” is generated by connecting two straight bars with scissor hinges away from the mid-points of the bars. In this case, the unit lines intersect in one point and the segment angle ( $\alpha$ ) varies during the deployment.<sup>4</sup> An “angulated scissor unit” is obtained by connecting two kinked bars instead of straight bars, with a kink angle between  $90^\circ$  and  $180^\circ$ ; the structure deploys radially and the segment angle ( $\alpha$ ) between two unit lines remains constant during the deployment. The unit-based method is an inductive design process and very effective in cases where the target geometry of the linkage is a well-defined form, or

where the intention is to create primary planar or spatial expandable geometries, like a planar arch, a linear beam or a dome-like shell. Spanish architect Emilio Pérez Piñero has pioneered the use of the unit-based method for expandable scissor linkages in architecture. He has developed many domes and spatial grids for functions like mobile theatres, pavilions and exhibition buildings.<sup>5</sup> Following Piñero, Félix Escrig Pallares and his colleagues expanded the topic and presented the geometric conditions of deployability of scissor linkages composed of “translational and polar scissor units”. They developed new spherical grid structures and several types

a. Translational spatial scissor linkage

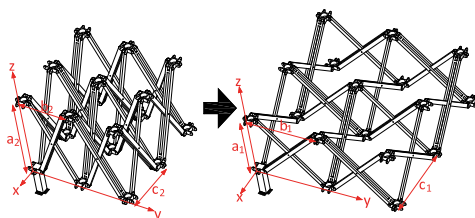

b. Polar spatial scissor linkage

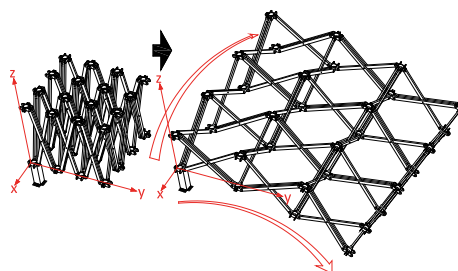

c. Planar linkage derived from angulated scissor unit

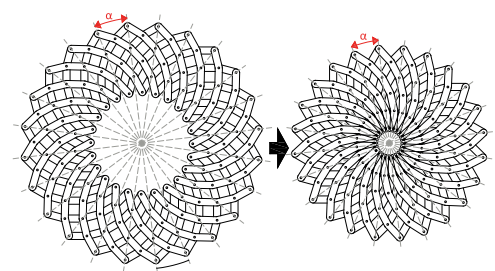

Spatial and planar scissor linkages and examples for their deployment

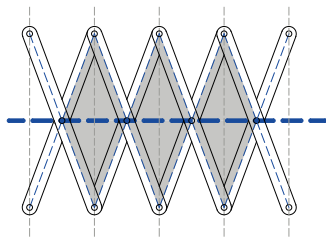

Rhombus loops

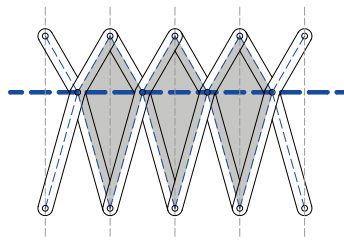

Kite loops

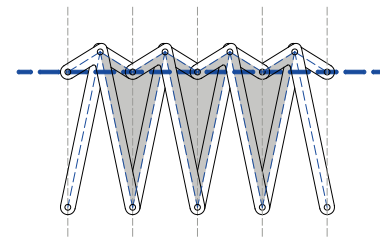

Dart loops

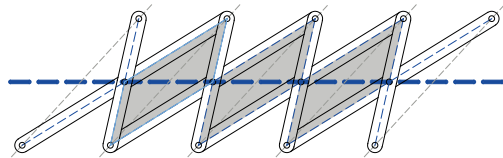

Parallelogram loops

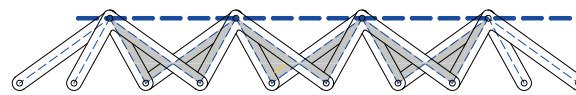

Anti-parallelogram loops

Loop types and the planar expanded scissor linkages that they produce

of expandable scissor structures, including quadrilateral expandable umbrella structures, expandable polyhedral structures and compactly folded cylindrical, spherical and geodesic structures.<sup>6,7</sup>

Chuck Hoberman made a remarkable invention on scissor linkages with the “angulated scissor unit”. The discovery of this element extended the range of applications of scissor linkages by allowing the linkage to be deployed from its perimeter towards the centre, creating an opening at the centre.<sup>8,9</sup> He designed the Hoberman Arch, the Iris Dome and a number of other structures using the angulated element.

Many other researchers, among them Zhong You and Sergio Pellegrino<sup>10</sup> as well as Charis Gantes,<sup>11</sup> have explained the main principles, geometric properties and shape limitations of both planar and spatial expandable scissor linkages.

## 2. Loop assembly method

The other approach for defining expandable scissor linkages is the loop assembly method. This method allows several combinations between different loops and the desired geometry, thereby providing

a practical way of designing scissor linkages with free-form curves. Rather than calculating individually each required link length and angle, a loop type is selected, and the desired number of loops are aligned on the curve. In the next step, the links and the primary scissor units are determined following the edges of the loops. In this way, the primary unit type/s is/are the result of this process, not its initial input.

This method was first used by Chuck Hoberman. He described the way in which identical angulated elements are paired to form angulated scissor pairs, with mechanisms that he termed “loop assemblies”. At a later phase, in a lecture given at MIT, he described his construction of expanding polygons as an assembly of “hinged rhombuses”.

The loop assemblies are formed by quadrilateral loops, which are the simplest movable loops. Quadrilaterals are called “rhombus”, “kite”, “dart”, “parallelogram” and “anti-parallelogram”, according to their geometry. If all four pairs of the quadrilateral loop are equal in length, it is defined as “rhombus”. If the two adjacent pairs are equal, it is called “kite”. A concave kite is called a “dart”. A “parallelogram”

is a convex quadrilateral with opposite sides parallel and equal in length; an “anti-parallelogram” is a quadrilateral in which each pair of opposite sides is equal but anti-parallel to the other two sides. By assembling such loops, expandable planar or spatial scissor linkages or shells can be obtained.

Different loop types can be applied to the same intended geometry. As described above, different types of loops can be located on a line, while the primary scissor unit and the deployment geometry differ according to the geometry of the loop type. Free-form planar geometries can be achieved by using different loop types. In this case, the deployment geometries are completely different. The loop assembly method is independent of the complexity of the intended form and can be adapted to any kind of planar expandable structure. The best way to proceed is to design the motion during expansion, or else decide intuitively which type of motion and loop is convenient for the intended design.

Within the framework of the loop assembly method, even a specific single type of loop can provide different kinds of geometric behaviour. For example, kite loops of identical size can be applied to shade

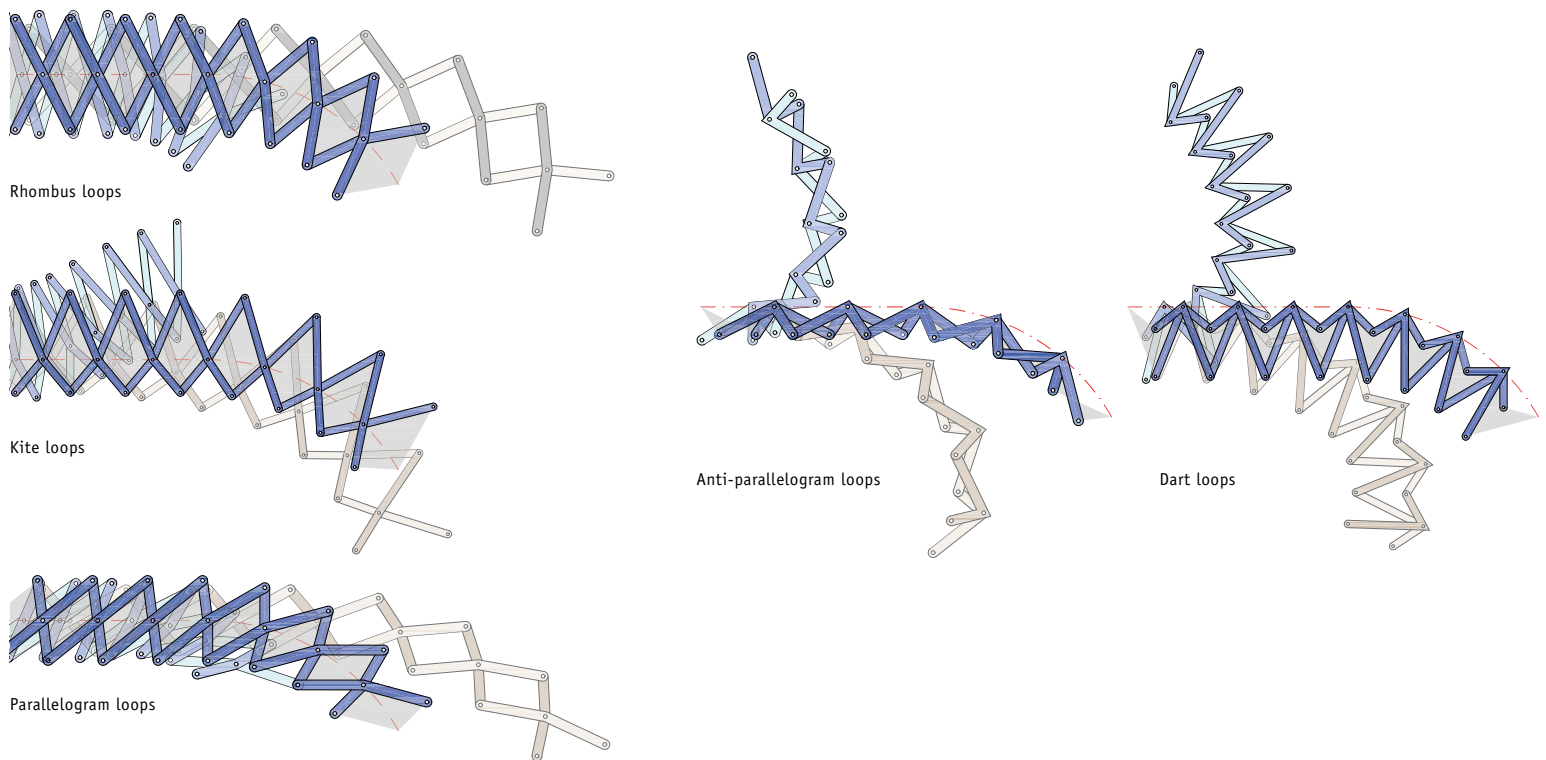

Expandable freeform scissor linkages with different loop types

structures with different assembly variations. Even though the loop geometry is identical, the ensuing primary scissor units as well as the deployment geometries differ significantly from each other.

### Summary

Scissor linkages are capable of forming various expandable structures. Architects can benefit from this type of linkage especially for designing adaptive, movable, transformable shell structures and deployable beam-like structures. Product designers may benefit as well.

The two different methods described here convey the basic design approaches. The unit-based method is very effective for obtaining primary geometries like a dome, arch, circle or line, using serial multiplications and arrays of one of the scissor unit types presented here. The loop assembly method is more convenient when a final form, be it straight or free-form, is the main point of departure. In this case, unlike in the unit-based method, it is not necessary to opt for a specific scissor unit type and its dimensional constraints from the beginning. Designers can choose a type and number of loops and

then define the scissor units following the loop sides. Since deployability is guaranteed by applying this method, the architect is free to choose the loop type most suitable for the functional needs and aesthetic concerns of the specific design. With the loop assembly method all loop alternatives can be assembled to scissor structures, their possible motions can be tested and evaluated in a short time, whereas the unit-based method is limited to a single type of motion that a specific unit can provide.

- 1 Tzonis, A.; Lefavre, L.: *Movement, Structure and the Work of Santiago Calatrava*, Basel, 1995.
- 2 Zuk, W.; Clark, R. H.: *Kinetic Architecture*, New York, 1970.
- 3 Hitchcock, H. R.: *Architecture: Nineteenth and Twentieth Centuries*, London, 1987.
- 4 Maden, F.; Korkmaz, K.; Akgün, Y.: "Review of Planar Scissor Structural Mechanisms: Geometric Principles and Design Methods", *Architectural Science Review*, 54 (3), 2011, pp. 246–257.
- 5 Piñero, E.P.: "Project for a Mobile Theatre", *Architectural Design*, 12, 1961, p. 570.
- 6 Escrig, F.: "Expandable Space Structures", *Space Structures Journal*, 2 (1), 1985, pp. 79–91.
- 7 Escrig, F.; Valcárcel, J.P.: "Geometry of Expandable Space Structures", *International Journal of Space Structures*, 8, 1993, pp. 71–84.
- 8 Hoberman, C.: *Reversibly expandable doubly-curved truss structure*, United States Patent No. US4942700A, 1990.
- 9 Hoberman, C.: "Mechanical Invention through Computation – Mechanism Basics", *MIT Class 6.S080 Lecture notes*, 2013, pp. 37–47, [http://courses.csail.mit.edu/6.S080/lectures/02\\_all.pdf](http://courses.csail.mit.edu/6.S080/lectures/02_all.pdf).
- 10 You, Z.; Pellegrino, S.: "Foldable Bar Structures", *International Journal of Solids and Structures*, 15 (34), 1997, pp. 1825–1847.
- 11 Gantes, C.: *Expandable Structures: Analysis and Design*, Boston, 2001.

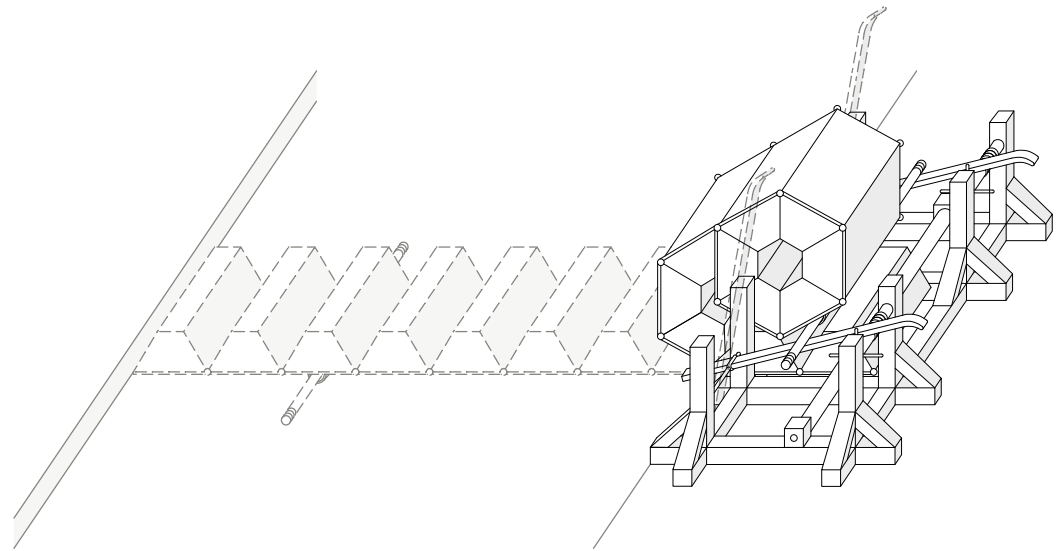

One of Ramelli's many ingenious designs for folding bridges

### ■ 3.4 Moving bridges

Cezary M. Bednarski

A mechanical opening bridge brings to the art of bridge design the fourth dimension – time, and with it the visual excitement of movement. An opening bridge can be subtly designed to have a minimal impact on, for example, a historic urban context. It is a valid proposition in locations where high navigation clearance is required, complex urban constraints are to be met, and the intensity of water course navigation is not in conflict with the intensity of traffic that is to cross over the bridge. There now exists also a relatively new driver, that of sustainable mobility. This includes the urban scale – the routes of most energy efficient travel in urban environments, both on land and water, which leads to bridges being used as tools of “urban acupuncture”. In many cases, an openable bridge is the only practical option. On the other hand, designers have to address the amount of energy used for operating moving bridges, as well as the ease and cost of their maintenance.

The idea of an opening bridge goes back to medieval times, and probably beyond. Initially devised mainly for defensive purposes, mostly as *closing* rather than *opening* bridges, enabling access for friendly visitors while preventing enemies' access to fortifications over moats. In our times this generic bridge type evolved into sophisticated mechanical systems. In terms of cost, in the context of navigation clearances, it can offer savings over high-clearance fixed bridges with ramps and approaches. An opening bridge is usually located at ground level, without high piers that would be needed to enable passage of high vessels below a fixed bridge, and without long approach ramps needed to reach these heights. The main functional drawback of openable bridges is the fact that traffic on the bridge must be halted when it is opened for water-based passage. Recorded historical examples of designs for opening bridges include ideas generated by Leonardo da Vinci (1452) and Agostino Ramelli (1531). Leonar-

do's revolving bridge designed for Duke Sforza was for military use, and it was not only openable but also transportable. It sat on a wheeled base and was operated via a system of pulleys. Da Vinci needs no introduction but Ramelli is relatively unknown. Born in 1531 in Ponte Tresa or Mesanzena, on the border between Switzerland and the Duchy of Milan, he was an Italian engineer and the designer of the *book wheel* (“reading wheel”). The wheel, considered to be an early prototype of hypertext and hence of the World Wide Web, presented the correct volumes of text to readers “regardless of the position in which they had last placed them”. In 1588, Ramelli published a book of engineering designs, *Le diverse et artificiose machine del Capitano Agostino Ramelli* (The Diverse and Artifactitious Machines of Captain Agostino Ramelli), in which he also presented a number of deployable bridges.<sup>1</sup> Although openable bridges, and particularly small bascule bridges, have been in use since ancient



Tower Bridge, London



Chikugo River Lift Bridge, Kyushu



Newport Transporter Bridge

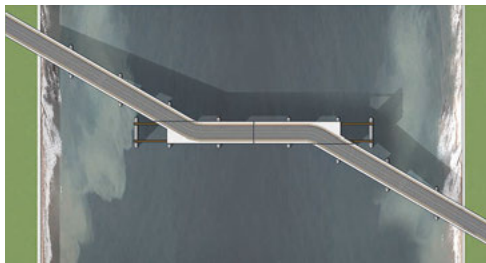
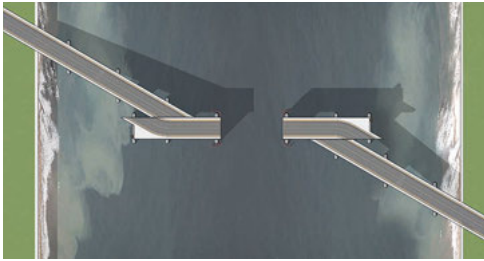

Retractable road bridge as a replacement for the Woolwich Ferry, London



Scissor bridge for cyclists and pedestrians on top the Thames Barrier, London

times, it was not until the 1850s that engineering methods were developed that enabled moving long, heavy spans quickly and efficiently.

There are basically nine types of openable bridges:

#### Retractable bridge

The rarest among opening bridge types is the retractable bridge, sometimes referred to as a thrust bridge. Its deck is rolled backwards, or sideways, to open a navigation channel for water traffic. It requires back, or side, space onto which the moving deck(s) can be retracted, and so its use is constrained to specific locations. Not many examples of retractable bridges are still in existence, a great majority among them being road bridges. The competition-winning Inderhavnsbroen pedestrian and cycle bridge (2016) in Copenhagen is the very latest addition to this select collection.

An 18th-century version of a retractable bridge was the Guthrie rolling bridge, patented around 1869 by one Mr Guthrie. Rolling bridges were not hinged, and remained horizontal as they retracted back into the gates of a fortification, and thus similar in operation to a modern retractable bridge. The Guthrie bridge was commonly installed as a means of access across narrow, steep ditches on the perimeters of polygonal forts of this era, for example in the forts of the Ports-down Hill line at Portsmouth, UK. The lifting arms of both bridges survive at Fort Nelson at Portsmouth. The Inderhavnsbroen (2016) in Copenhagen is a retractable bridge that facilitates ship movement along a 50m wide navigation channel. Its total length is 180m. Fixed concrete twin decks are 4m

wide each, and the moving steel decks are 8m wide. The bridge is a key component of a scheme which creates a crucial link between two parts of Copenhagen separated by the port. The opening part of the bridge utilises a unique sliding mechanism with each moving deck resting on a set of forged front twin wheels, each 1.8m in diameter, strawberry red in colour, and two sets of rear bogies. Besides its low profile and minimal obstruction to views along and across the harbour, the bridge's main attraction is that people can stand on viewing platforms right at the edge of the navigation channel, even when the bridge is open.

In London there has been a connection between what are now Woolwich and North Woolwich across the Thames since the Norman Conquest. The area was mentioned in the 1086 *Domesday Book*. State papers from 1308 show that a service was running between North Woolwich and Warren Lane. Cross-river traffic increased following the establishment of the Royal Arsenal in 1671. By the end of the 1920s, the rise in motor traffic had put pressure on the ferry's capacity. There are no road bridges across the Thames between the Tower Bridge and the QEII Bridge. Besides three tunnels, regularly closed for maintenance, there is only the free Woolwich Ferry. In 2004, planning applications were submitted for a new bridge, the Thames Gateway Bridge, close to the location of the Woolwich Ferry. This was a high bridge; costly and opposed by environmental lobbies, the project was cancelled in 2008. A 2015 Woolwich ferry replacement concept involved a retractable low-level road bridge, with unrestricted air

draught height and 61m width clearance, matching the Thames Barrier. Its two sliding decks retract to provide navigation width. A slight kink in the plane of the bridge facilitates one-sided deck movement and keeps traffic speeds low, a desired outcome considering traffic constraints at both ends of the bridge. Tower Bridge, upstream from Woolwich, opens and closes approximately 1,000 times per year, or three times per day, meaning that the proposed bridge would be open for road users for most of the day and would be retracted and open to water navigation only a fraction of the time.

#### Bascule bridge

Tower Bridge in London (1894), a classic double bascule, is among the most recognisable bridges ever built. Its construction started in 1886 and it was opened on 30 June 1894. It was built to ease road traffic while maintaining water access to the Pool of London docks. The central deck spanning 61m between its two towers is divided into two equal leaves, which rise to an angle of 86°, allowing river traffic to pass. The bascules, weighing over 1,000 tons each, are counterbalanced to minimise the force required and allow swift raising. The Wabash Avenue Bridge across the Chicago River in Chicago, with its main span of 82m, is another double bascule bridge. In 1930, when it was first opened, the American Institute of Steel Construction named it the "Most Beautiful Steel Bridge". It is located east of Marina City and was designed by Thomas Pihlfeldt and built by the Ketler and Elliot Company.

A scissor bridge is a variation on the bascule theme. The Thames Barrier, completed in 1982, spans 520 m across the river Thames near Woolwich, and protects 125 km<sup>2</sup> of central London from flooding caused by tidal surges. It has 10 steel gates that can be raised into position across the Thames. Since 1928, design studies have shown Thames barrages with road crossings above them, but the Thames Barrier does not provide a crossing. This idea was to place a foot and cycle deck atop the barrier piers, with opening sections where required. The bridge would link a new development area and Green Link linear park, reaching the Thames at Charlton on the south side of the river, with Newham on the north. The proposed scissor-like lifting decks would be fully counterbalanced. It was a study showing that opening bridges could be conceived even as “parasitic organisms” atop existing structures, and how their design could encompass rational and functional beauty.

The Hörnbrücke (1997) is another variation of a bascule bridge type – a folding bridge. Located in Kiel, the capital of the German state of Schleswig-Holstein, it spans the end of the Kiel Fjord (called Hörn) and connects the city centre on the west bank of the Hörn with the Gaarden quarter on the east bank. Designed by the German architecture firm Gerkan, Marg & Partner (gmp) and the German engineering studio Schlaich Bergermann Partner (sbp), it is a three-segment bascule bridge with a deck width of 5 m and a main span of 25.5 m, which folds into an N-shape. Despite initial teething problems,

the Hörnbrücke is regarded as a technical masterpiece and a tourist attraction.

#### Turning bridge

In 2015, the city office of Gdańsk, a historic port city in northern Poland, held a design competition for an opening bridge for a site located next to Europe’s oldest and largest surviving port crane, dating back to 1444. Studio Bednarski working with spb won this competition with a turning bridge design. Based on the pragmatic Baltic traditions, the design optimises functionality, not letting the bridge become a manifestation of an extravagant structural form. Its total length is 49.31 m, with spans of 28.85 m and 20.29 m. The form-making was consciously constrained to keep the overall bridge width to a set minimum of 4.5 m, with minimal intervention at either side of the river. It is a bridge without abutments. The design is a low-key functional work of art: a water-based sculpture, which emerges when the bridge deck is turned onto the island. It has a double role: that of a component of an object of art, while also protecting the steel deck from ship impact. This makes the use of protective dolphins unnecessary and reduces the impact of the bridge on the navigation width, as well as reducing visual clutter related to the bridge.

#### Transporter bridge

A transporter bridge is akin to a suspended ferry, being more efficient than a conventional ferry. A

high-level beam which rests on two towers allows ships to pass underneath it. A moving carriage runs on a rail track carried by the beam, and a travelling platform is suspended from the carriage. It is pulled from one side of the river to the other by a hauling cable. Although an “aerial ferry” concept was first drawn by the English engineer Charles Smith, the first working transporter bridge was built in 1893 at Portugalete near Bilbao in Spain, by Spaniard Alberto Palacio and Frenchman Ferdinand Arnodin.

In 1900, Newport, Wales, was a very busy port, much of it centred up the river Usk. With the industry on the east side of the Usk and the population largely based on the west side, people had to walk 4 miles to cross the river over the town bridge to reach work. A ferry service was not reliable because of the changing times of the tide and its extreme amplitudes. The Newport transporter bridge opened on 12 September 1906, becoming a landmark feature of Newport’s skyline. It is powered by twin 35 horsepower electric motors and is now listed as one of only six operational transporter bridges left in the world, from a total of some 20 that were built.

#### Lifting bridge

The Chikugo River Lift Bridge (1935) in Kyushu, Japan, is a movable bridge with a central part that lifts to allow ship passage. Spanning the mouth of the river, it was used by the JR Saga trainline of the old Japanese National Railway. The bridge has a total length of 507 m with a movable span of 24 m.



Hörnbrücke in Kiel – a combination of bascule and folding bridge



A floating bascule footbridge at West India Quay, London



Front and side elevation of the bascule bridge for cyclists and pedestrians at Świętego Ducha in Gdańsk

The vertical rise is 23 m. It links Ōkawa, Fukuoka with Morodomi, Saga. After the discontinuation of the train line in 1987, the bridge was listed as a National Important Cultural Property, and in 1996 reopened as a part of a walking trail.

### Tilting bridge

A tilting bridge is a type of movable bridge that rotates about fixed-end pivots rather than lifting or bending. The tilting Gateshead Millennium Bridge (2001) spans the River Tyne and links Gateshead and Newcastle upon Tyne, England. Two large hydraulic rams at each end of its arch tilt the structure back, allowing small watercraft to pass below. The curved pedestrian and cycle pathway is nearly horizontal, suspended above the river from a slightly inclined parabolic arch. To raise the bridge, the entire assembly rotates as a single, rigid structure. As the arch tilts down, the deck rises.

Two tilt bridges were constructed in Belgium in 2011. The Scheepsdalebrug (2011) in Bruges com-

bins the mechanics of a rolling lift bascule bridge and a tilt bridge. The bridge is mounted on two lifting arms that roll along racks, parallel to the canal, tilting up the bridge deck to provide clearance for ships. The Sint-Annabrug Bridge (2011) over the river Dender in Aalst is mounted on two lifting arms connected to pivot points downstream from the bridge deck.

### Openable floating bridge

The Hood Canal Bridge (1961) is an openable floating bridge in the State of Washington, USA. It carries State Route 104 across Hood Canal of Puget Sound and connects two peninsulas. With a total length of close to 2.40 km and a floating portion of almost 2 km, it is the longest floating bridge in the world located in tidal saltwater, and the third longest floating bridge in the world. Its retractable draw span is 183 m long. It is the second concrete floating bridge built in the state of Washington.

A much smaller floating bridge, with an openable central part, is a lime-green steel footbridge in West India Quay in London by Future Systems and Anthony Hunt. Floating on steel floats 2.8 m in diameter, it looks like an insect on a pond. Completed in 1996 as a shortcut between Canary Wharf and West India Quay, it is 94 m long, with a clear span of 80 m.

Where, how, when and why opening bridges should be considered, even as “parasitic organisms” atop existing structures, and how their design could encompass rational and functional beauty, which combines logical and efficient structures with elegance of movement, is a great challenge. Opening bridges are intriguing structures that call for the ingenious meshing of statics with the mechanics of movement.

1 Agostino Ramelli: *The Various and Ingenious Machines of Agostino Ramelli*, transl. Martha Teach Gnudi, London, 1988.



Buildings  
and building  
elements

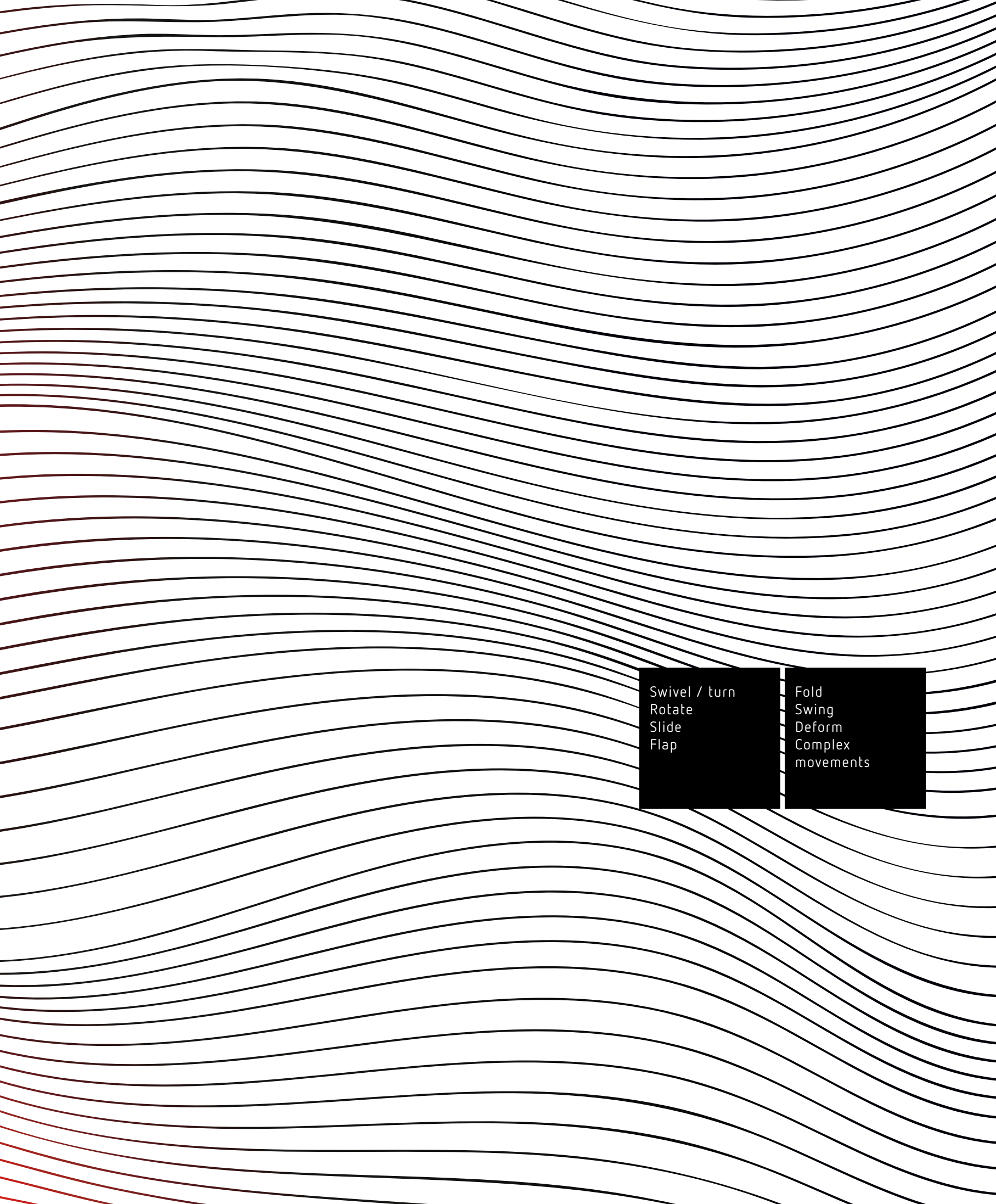

Swivel / turn  
Rotate  
Slide  
Flap

Fold  
Swing  
Deform  
Complex  
movements

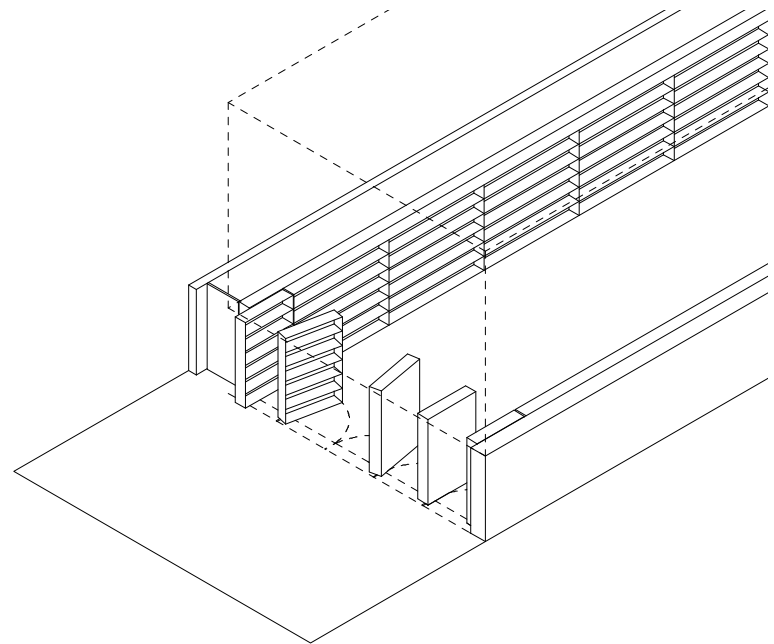

Axonometric projection of bookshop entrance

## Livraria da Vila

São Paulo, Brazil, 2007  
Isay Weinfeld

In 2007, a two-storey building on a narrow plot in São Paulo was converted into the Livraria da Vila bookshop. The design idea of architect Isay Weinfeld was to create an open floor plan that makes books its central theme, through a series of significant interventions in the structure of the building. Loadbearing columns and walls in the sales area were removed and the loads transferred to the outer walls via steel girders. The space thus freed up made it possible to reroute paths within the building, using furniture and interior furnishing that

present the books to guide movement through the building.

All internal walls, staircases and balustrades are designed as bookshelves, and numerous opportunities to sit down with a book were included to complement its library-like character. On the ground floor, all the wooden fittings and furniture are black, while in the basement they are all white.

On the main facade, five rotating bookshelves create a special entrance situation. Designed as glazed display cases in the same style as the bookshelves,

they form the street frontage of the bookshop and act as the shop window. When the shop opens, the display cases swing back into the interior about an axis on one side of the bookshelves, beckoning customers into the bookshop.

A swivel bearing at the base and an upper pin attached to the steel frame of the swivelling bookcases allow them to be opened by hand. They are faced with safety glass on the outside and closed with doors on the inside. The shelf becomes a showcase and the showcase becomes a shop window.



Open shop front



Closed shop front



Rotating bookshelves as facade elements

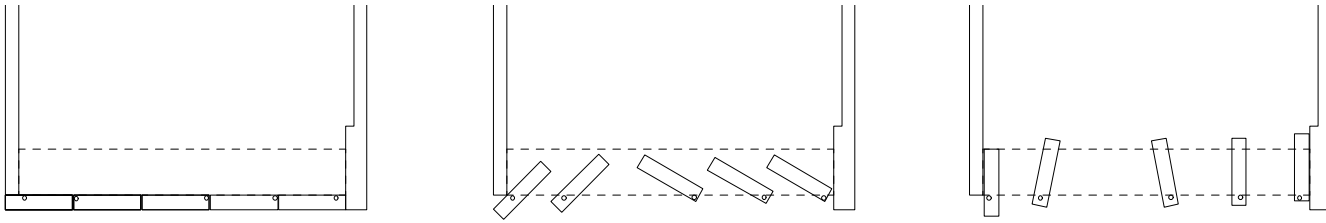

.....  
**Dimensions** L × W × H = 1.62 × 0.35 × 2.44 m **Number 5** **Drive Manual**

- |                                   |                             |
|-----------------------------------|-----------------------------|
| 1 Mounting bracket                | 7 Laminated glass, 10 mm    |
| 2 Crosspiece                      | 8 Glazed opening section    |
| 3 Swivel pin, stainless steel     | 9 Bookshelves, removable    |
| 4 Swivel bearing, stainless steel | 10 Base, stainless steel    |
| 5 Frame profile 12 × 35 mm        | 11 Floor covering, coir     |
| 6 Glazing bead, multiplex         | 12 Precast concrete element |

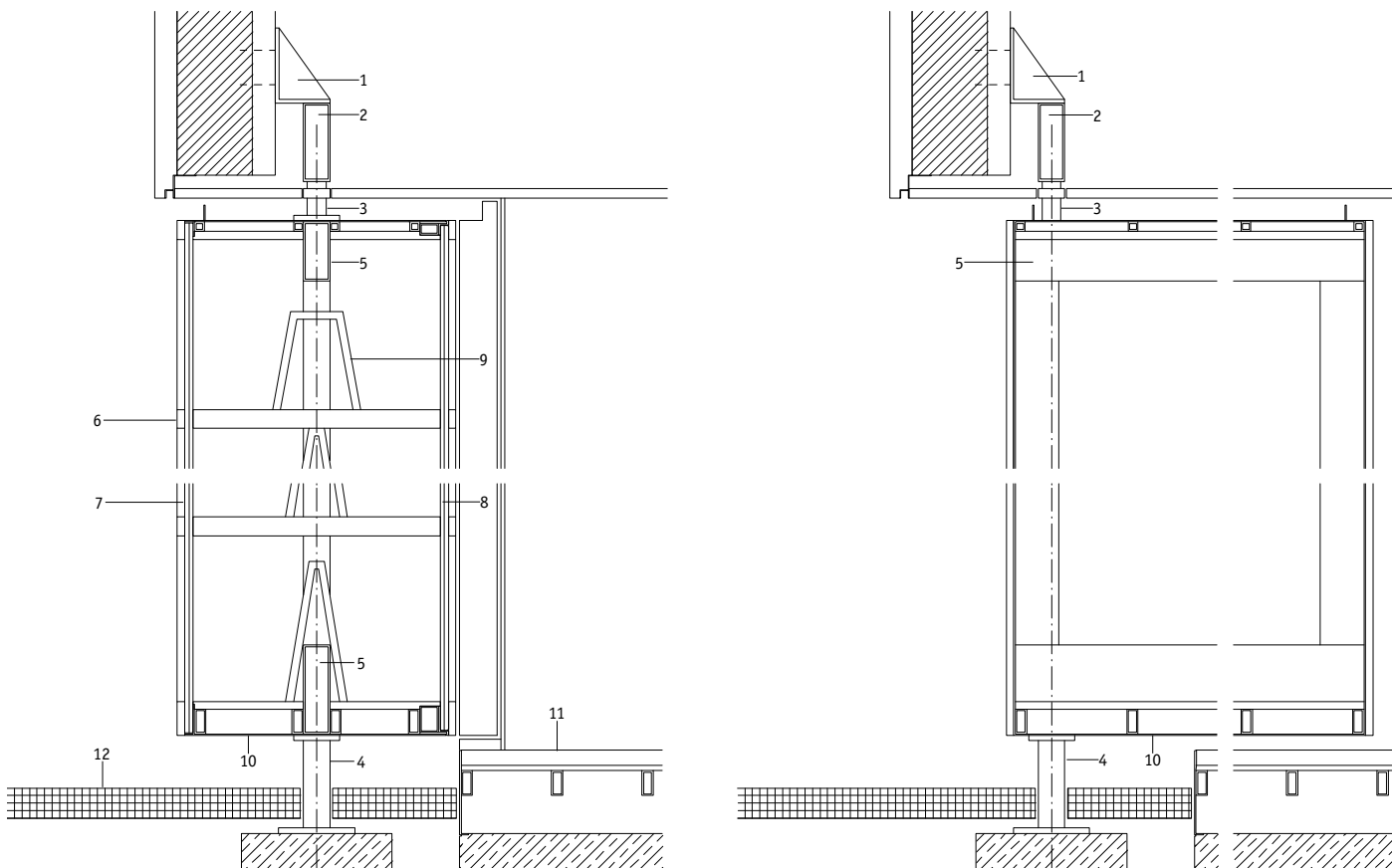

Vertical section with closed and open facade element, 1:10



## Sharifi-ha House

Tehran, Iran, 2013  
Nextoffice + Alireza Taghaboni

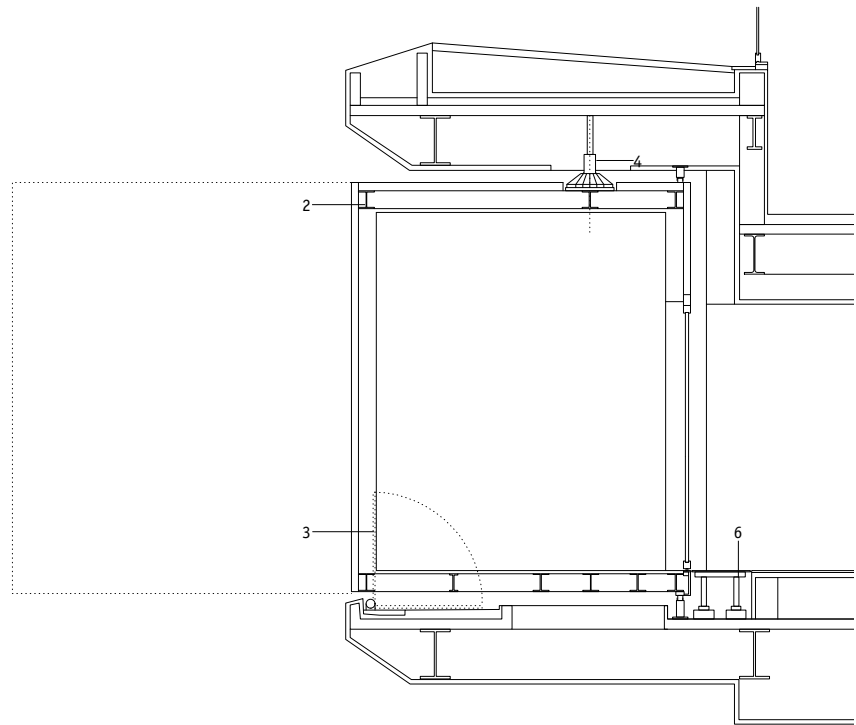

Vertical section (not to scale)

The Sharifi-ha House, the name of which is a reference to traditional Iranian villas, is located in Tehran. The concrete structure comprises 1400 m<sup>2</sup> living area distributed across seven floors on a narrow plot measuring 11 × 33 m, with the narrow south-facing facade as the only open frontage. Its design is by the local architecture firm Nextoffice.

The basic idea of the house is a structure that can quickly and flexibly adapt to the needs of its residents. Three wood-clad room boxes can be rotated independently of each other out of the facade by 90° to increase the amount of living space by up to 20 m<sup>2</sup> per box.

The design was inspired by traditional Iranian villas, which often have two living rooms, one for the sum-

mer and one for the winter months. The building reinterprets this arrangement using modern means by changing its shape in response to the seasons. While the facade is largely closed in winter, the boxes are rotated outwards in summer, protruding 3 m beyond the front face of the building and revealing a glazed facade and loggia.

The boxes consist of rigid steel frames made of wide-flange steel H-beams (HEM 160), insulated and clad with wooden planking on the outside. Each box has two French doors arranged at right angles to each other so that the boxes can be accessed in both positions. An airtight seal between indoors and outdoors is achieved using pneumatic sealing strips

and the precise start/stop positions of the rotating elements is ensured using absolute encoders.

The house's state-of-the-art facilities include a KNX smart home system that controls the rotation of the three room boxes. A specially developed, electronically operated turntable permits rotation through 90°, while at the top, the boxes are only fixed in the axis of rotation. The actual turning process takes just under 20 seconds but to ensure smooth, uninterrupted rotation, the loggia balustrade first folds down and the floor areas in front of the box are lowered, so that the overall process takes approximately two minutes.

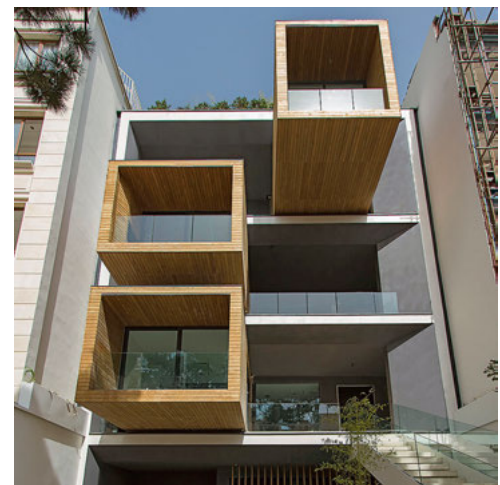
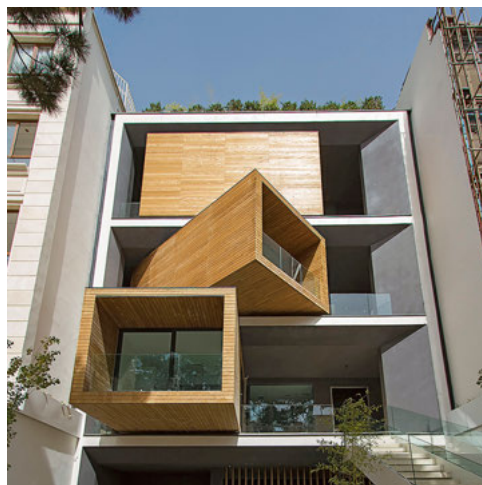

Opening sequence of the rotating boxes

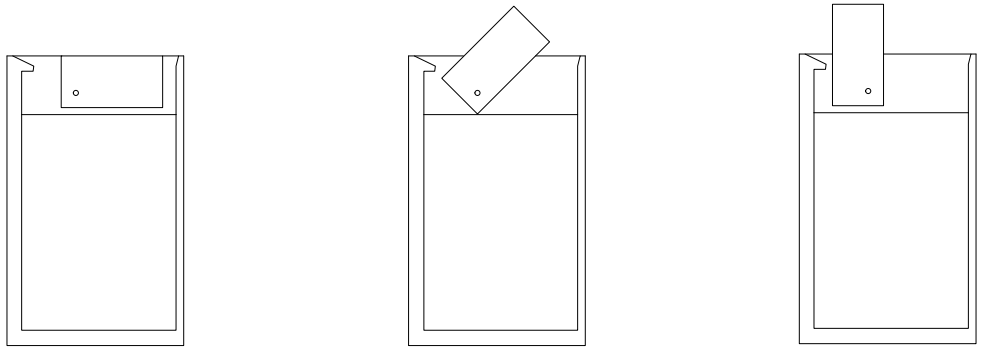

0:00

0:10

0:20

min:sec

Dimensions W x L x H = 3.40 x 6.80 x 4.20 m Number 3 Weight per element 25 tons (box weight + usage weight)

- 1 Timber cladding, horizontal, 20 mm
- 2 Steel skeleton framework, HEM 160 steel girders
- 3 Glass balustrade, fold-down
- 4 Pivot
- 5 Pneumatic seal
- 6 Lowerable floor element

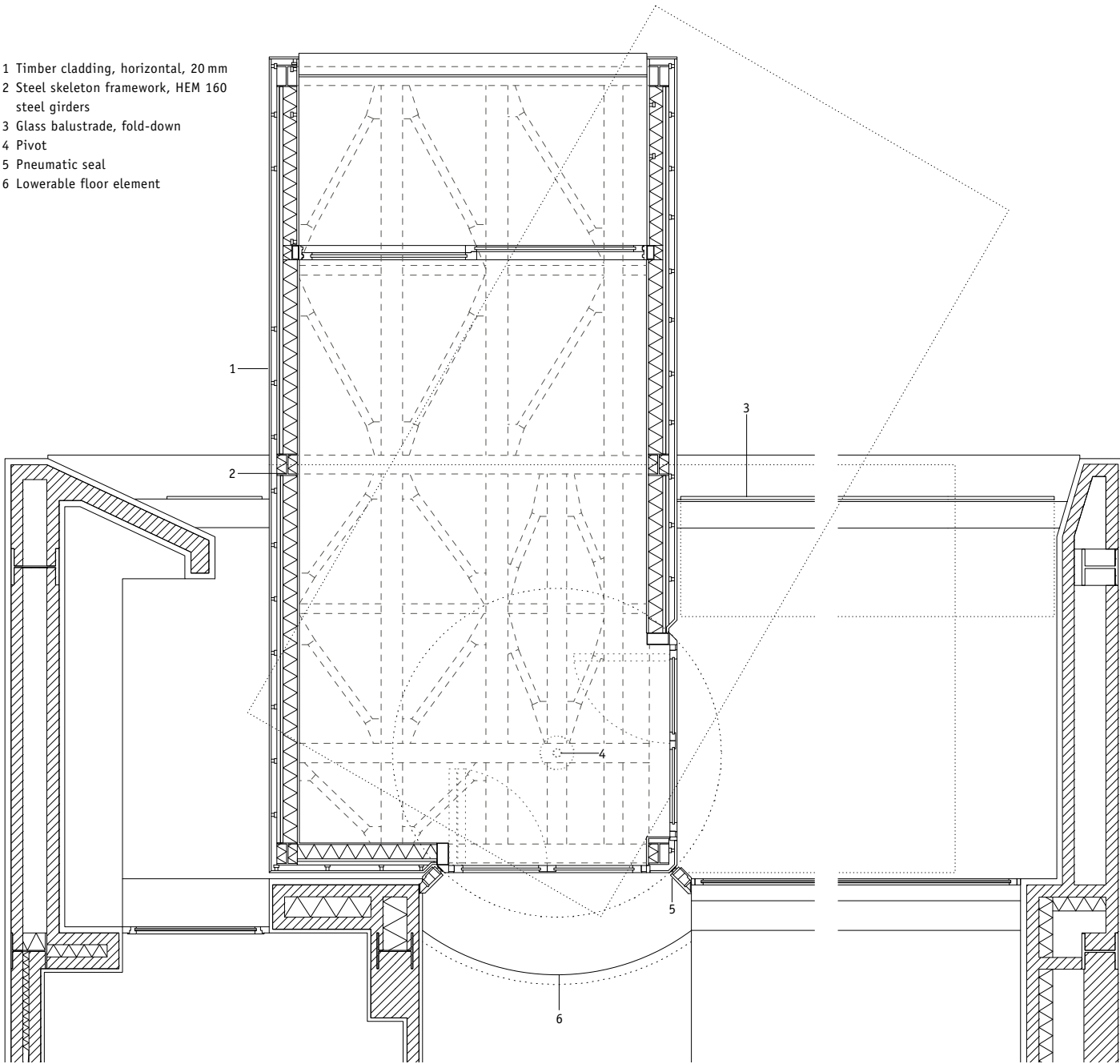

Floor plan, level 6th upper floor, 1:50

Swivel / turn



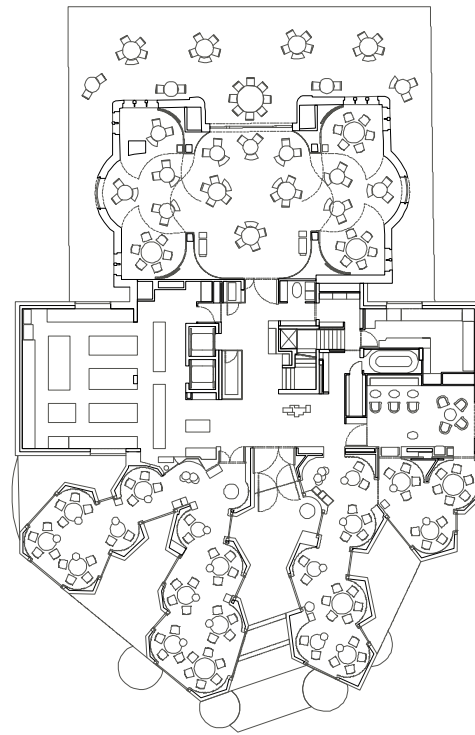

Ground floor plan, 1:500

## Steirereck Gourmet Restaurant

Vienna, Austria, 2015  
PPAG architects

In 2012, despite comprehensive renovation a few years earlier, the Steirereck restaurant in Vienna's Stadtpark set out to find a new concept for the conversion and extension of the historic guesthouse. An invited competition was organised, which was won by the Viennese architecture office PPAG architects. The competition-winning design proposed a concept that blurs the boundaries between indoors and outdoors so that guests feel as if they are sitting outside in the park. The complex configuration of branching spaces results in a natural separation of tables, all of which adjoin a window. Large vertical sliding windows offer occupants of the new extensions unobstructed views of the park. From outside, the slightly reflective metal facade looks as if it is covered with dew and through the many, broken

reflections of the surrounding park blends into or stands out from the surrounding greenery, depending on the incidence of light.

The facade material continues from the extension into the interior of the existing, historically listed restaurant, where the reflective aluminium panels serve as lightweight wall partitions. The majority of them are connected by hinges and are movable to create different configurations that alter the size and proportion of the restaurant interior. A number of different usage scenarios were planned to suit different table occupancies and occasions.

The ceiling above the dining area, which recalls an inverted contour model, along with the unfolding wall elements, which neatly fit the stepped ceiling profile, create a range of different room situations.

The 7 cm thick, movable wall elements are composed of two to three folding sections attached to the wall via a door hinge. The individual elements are made of 7 cm thick, matt reflective aluminium panels, which are CNC machined to match the ceiling heights and mounted on a framework of hollow steel sections and steel flats. The individual sections are connected by concealed folding door hinges and each can be anchored in position for safety reasons. A roller at the far bottom edge of each panel segment takes up the load on the extended panels. The wall sections are unfolded or retracted by hand by the restaurant staff.



Mirrored facade of the extension with vertically movable raised elements



New interior of the existing restaurant with movable wall elements

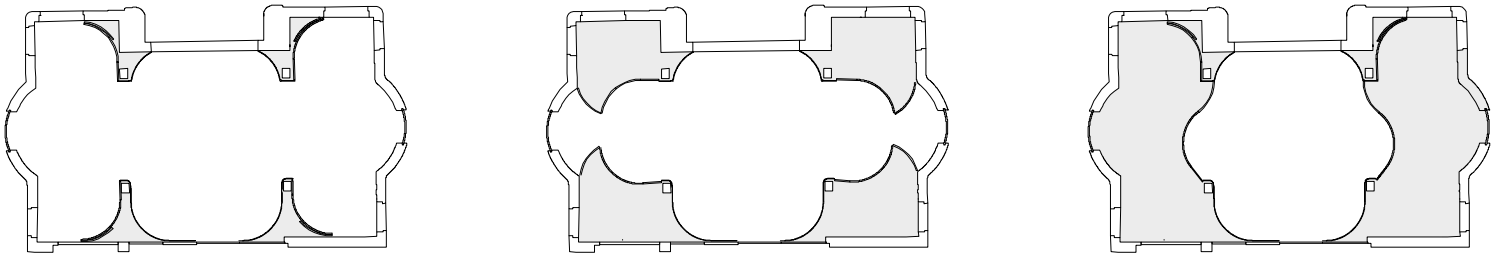

Dimensions L x W x H = 1 - 3.50 x 0.07 x 2.40-2.90 m Number 4 (comprising 2-3 sections) Drive Manual

- 1 Aluminium panel 5 mm, matt reflective
- 2 Hollow steel sections, 50 x 50 mm, as panel frame
- 3 Panel hinges, concealed
- 4 Contoured ceiling
- 5 Aluminium panel 5 mm, matt reflective, fixed
- 6 Supporting roller

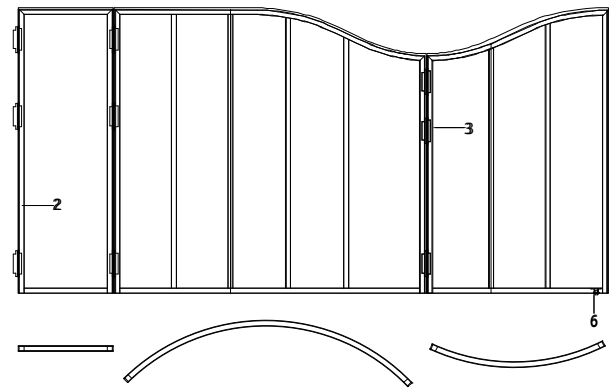

Flattened elevation of folding wall, 1:50

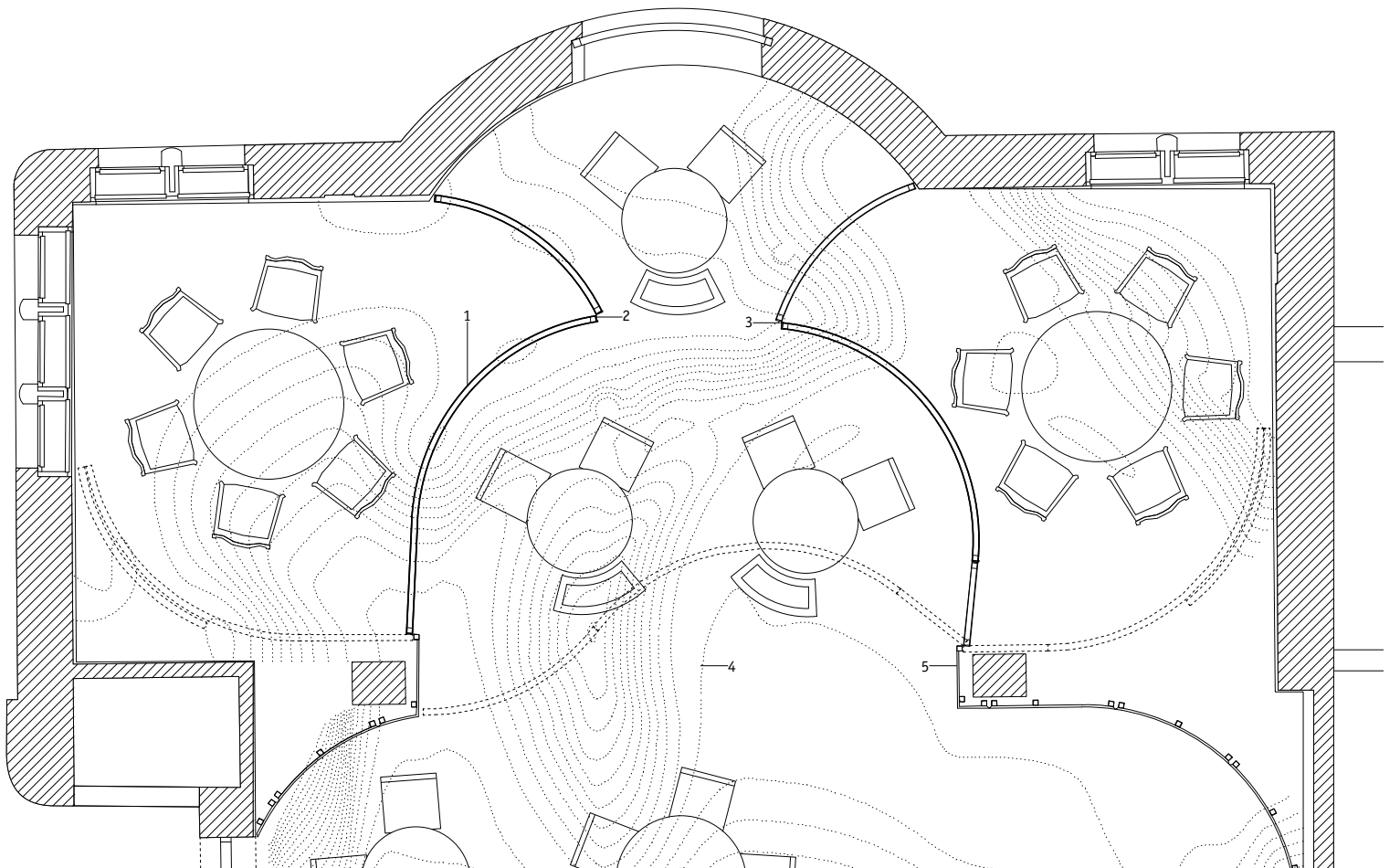

Floor plan of the existing restaurant interior, 1:65



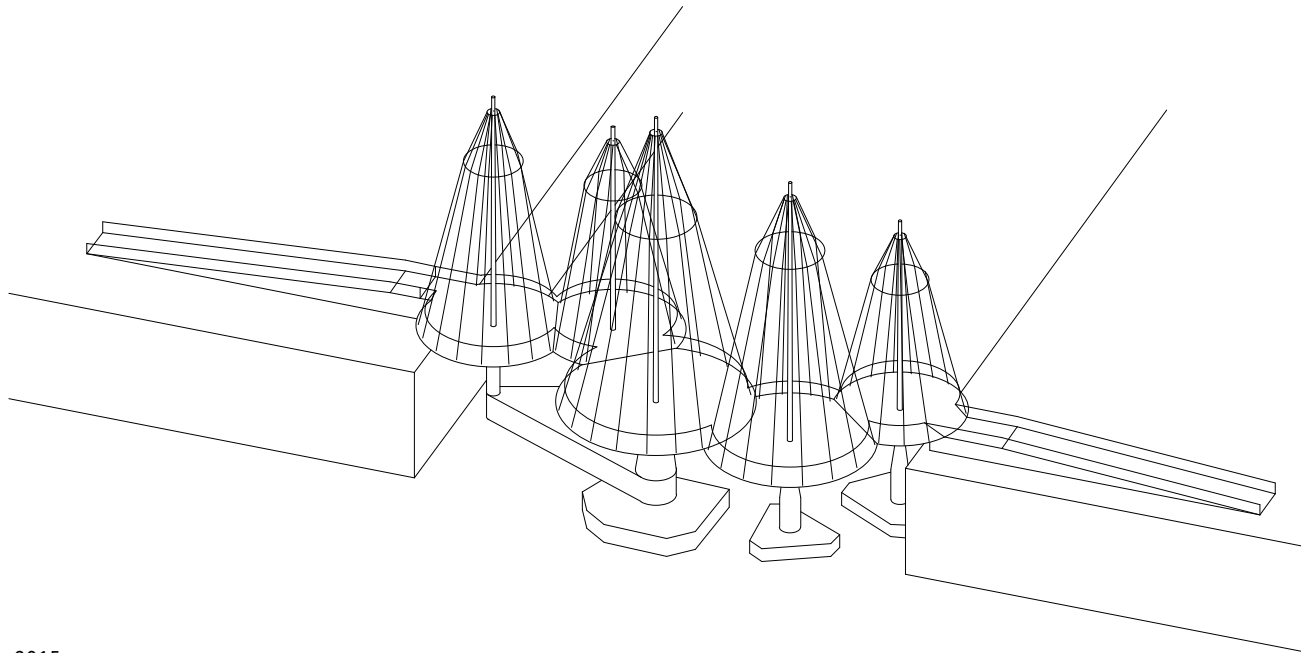

## Cirkelbroen

Copenhagen, Denmark, 2015  
Olafur Eliasson

Axonometric projection of the bridge including submerged buoyancy tank of the swivel arm and mountings

The bridge's name – Cirkelbroen, the circle bridge – describes both its shape and function. Spanning Copenhagen's Christianshavn Canal, it is crossed by some 5,000 cyclists and pedestrians every day. Its distinctive appearance evokes associations with a series of boats moored next to each other, so that one can cross the canal by walking from boat to boat. The bridge is a gift from the Nordea-fonden to the city of Copenhagen.

The 35 m wide canal is bridged by a 40 m long cluster of five different-sized intersecting circles. Two are fixed in place on the base of the canal, while the other three form a swivel arm that allows the bridge to open to permit larger boats to pass. The diameters of the circular sections range from 9.40 m

to 13.30 m and together form a bridge area totalling 439 m<sup>2</sup>. From the centre of each platform, a mast rises to a height of between 17.50 and 25 m, tapering conically from a diameter of 30 cm at its base to 20 cm at its tip. The circular sections are suspended from the masts by 118 10 mm stainless steel cables. The bridge sections, substructure, masts and railings are all made of steel, with beige granite flooring for the bridge deck. Concrete ramps, clad with black granite, rise gently over a length of approximately 20 m at each end of the bridge, connecting to the circular bridge sections via a short stretch of timber decking.

The central circular section that forms the pivoting element stands on a two-part pillar on a concrete

foundation. While the inner part of the pillar is anchored securely to the foundation, the outer part connects to the supports of the two other platforms of the swivel arm via an underwater air-filled buoyancy tank and can swivel around the inner part of the pillar. The rotating action is activated by hydraulic cylinders inside the platform.

Small boats can pass beneath the bridge through a 7.70 m wide opening with a clearance height of 2.25 m. To allow larger vessels to pass, the swivel arm of the bridge can rotate to one side by 64° in about 20 seconds to provide an approximately 9 m wide open passage.



Closed state with pedestrian crossing

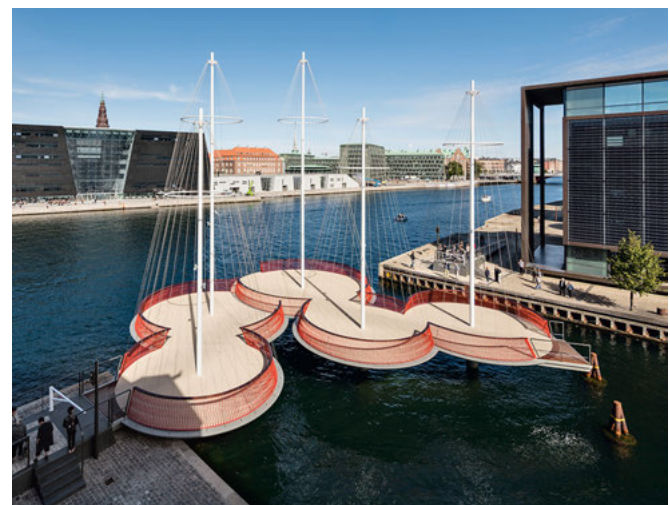

Open state

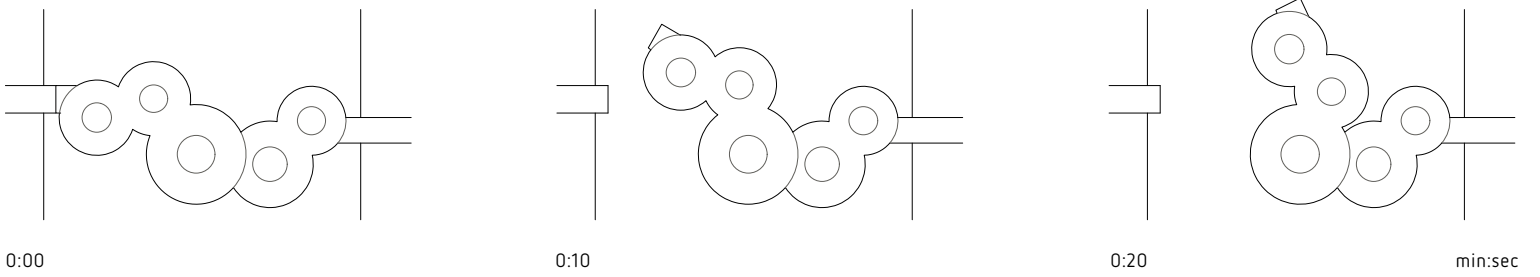

Dimensions  $\varnothing$  9.40–13.30 m Number 5 platforms Weight of swivel arm 78 t

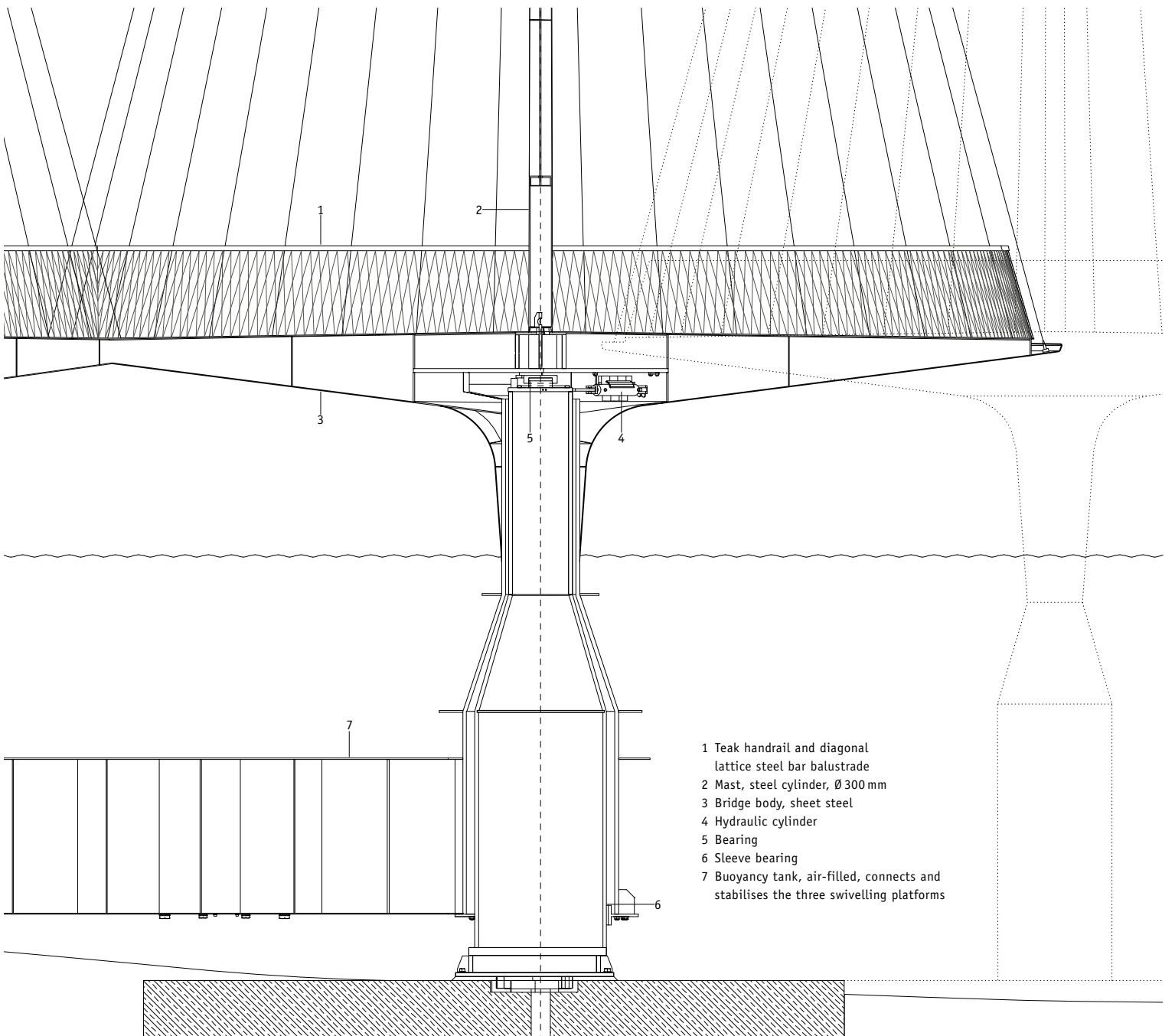

- 1 Teak handrail and diagonal lattice steel bar balustrade
- 2 Mast, steel cylinder,  $\varnothing$  300 mm
- 3 Bridge body, sheet steel
- 4 Hydraulic cylinder
- 5 Bearing
- 6 Sleeve bearing
- 7 Buoyancy tank, air-filled, connects and stabilises the three swivelling platforms

Section through rotating platform, 1:75

Swivel / turn



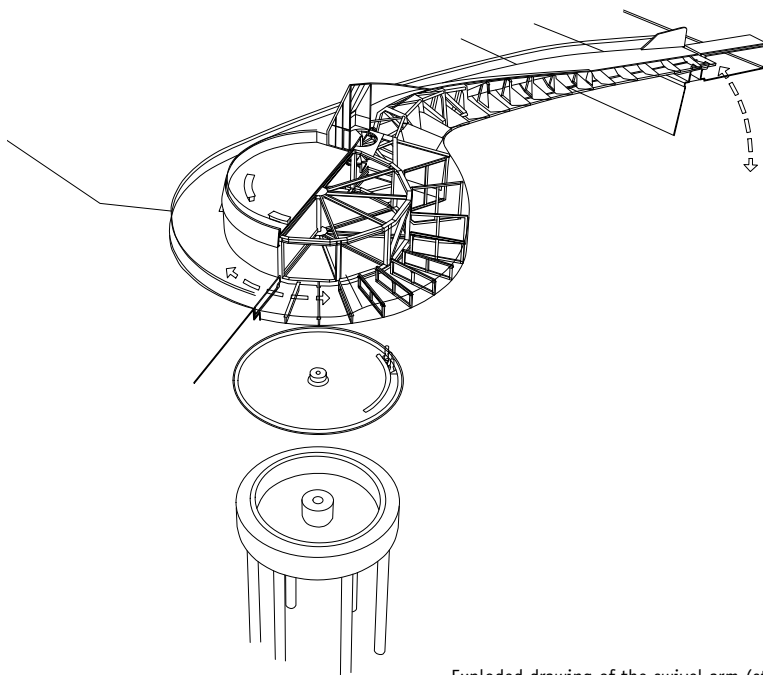

Exploded drawing of the swivel arm (steel structure) showing movement mechanism and support

## Scale Lane Bridge

Hull, Great Britain, 2013  
 McDowell + Benedetti Architects  
 Alan Baxter Ltd (Structural engineers)

The Scale Lane Bridge spans the River Hull in Kingston upon Hull and, according to the city, is the first footbridge in the world to permit pedestrians to remain “on board” during operation. The 1,000t cantilever bridge construction is anchored on the west side of the navigable canal and projects horizontally over the water. While smaller boats can pass beneath it, the bridge opens to allow larger vessels to pass, as well as at certain pre-announced times of the week as a public attraction. The bridge was the winning entry in an international 3-stage design competition held in 2005.

The opening and closing sequence lasts about two minutes. Once the gate at the eastern end of the bridge has been closed, the bridge starts to move. There is no barrier at the western end and pedestrians can safely step on and off the bridge while it rotates at the slow-moving speed of less than 0.15 m/s.

The structure consists of a steel spine cantilevering from a three-dimensional braced ring with a diameter of 16 m that acts as the hub. The projecting spine is a hybrid structure with the root section conceived as a diagrid and the tip as a shell. Steel

plates clad the surface of the walkways while horizontal bracing provides additional longitudinal stiffness.

The bridge is supported on a series of six single and four double wheel assemblies that run below the hub on a flat, circular track similar to a railway turntable. The Scale Lane Bridge is driven by three electric bevel gears and rotates around a central slew bearing secured to a concrete drum supported on 1.60 m diameter 30 m long piles.



Bridge opening sequence

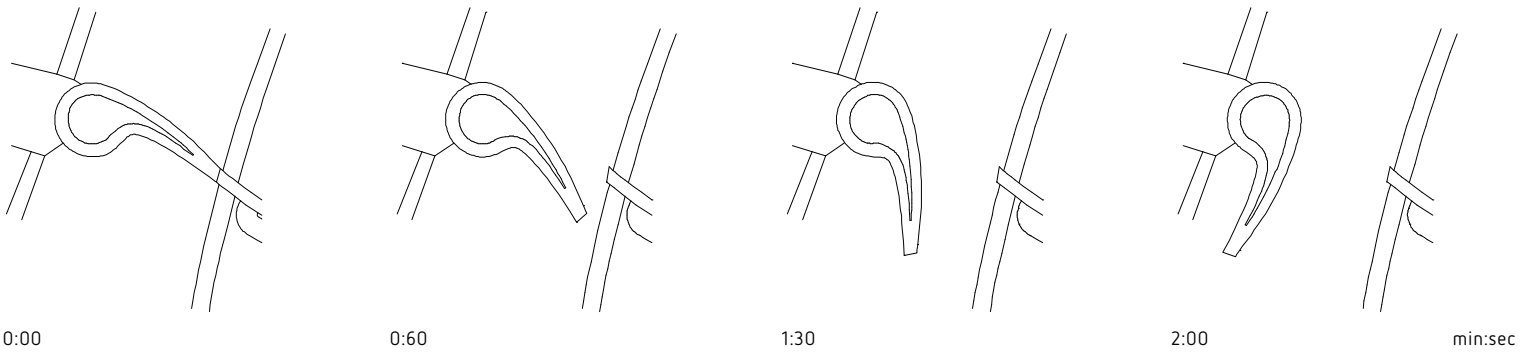

Dimensions d = 16 m; overall length 57 m; cantilever 35 m Weight 1,000 t

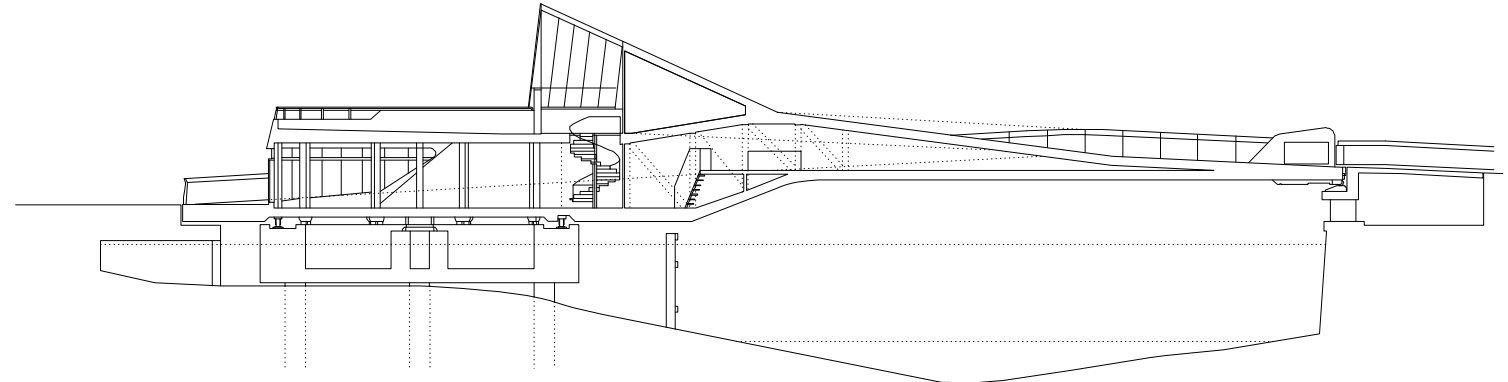

Section, 1:500

- 1 Bevel gear drive
- 2 Perimeter I-beam
- 3 Toothed rack
- 4 Ring bearing, concrete, Ø 17 m
- 5 Central steel support, round, Ø 36 cm
- 6 Circular track, Ø 1.60 m
- 7 Stabilising roller

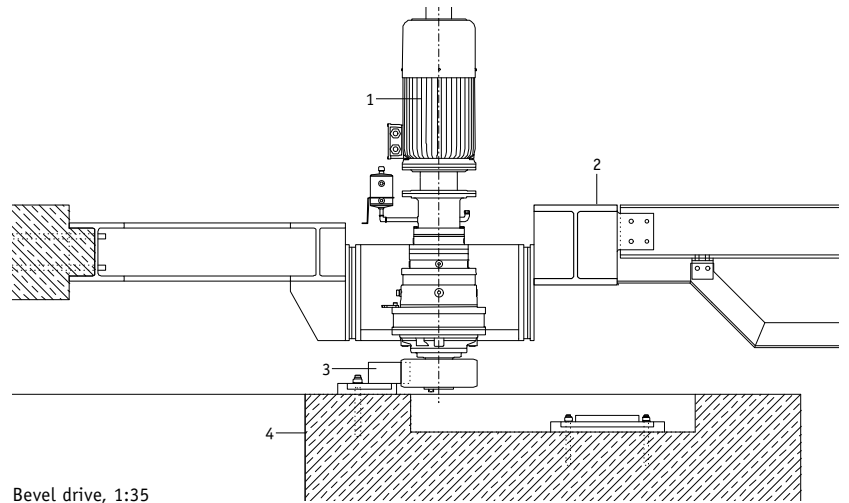

Bevel drive, 1:35

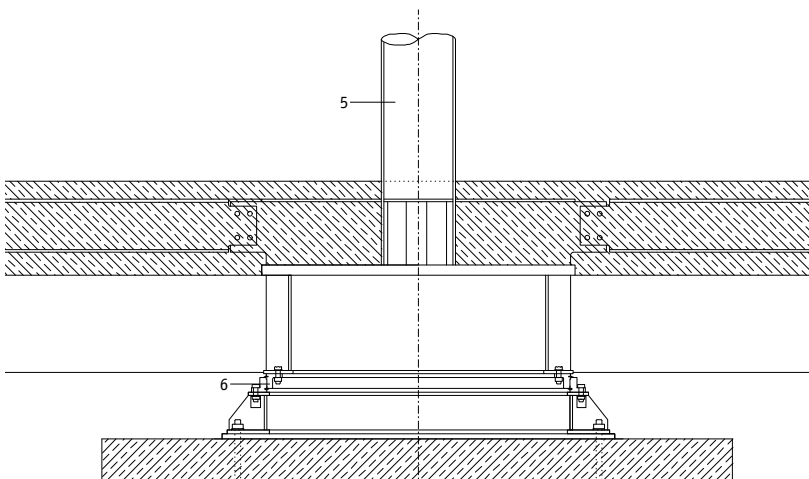

Central spindle, 1:35

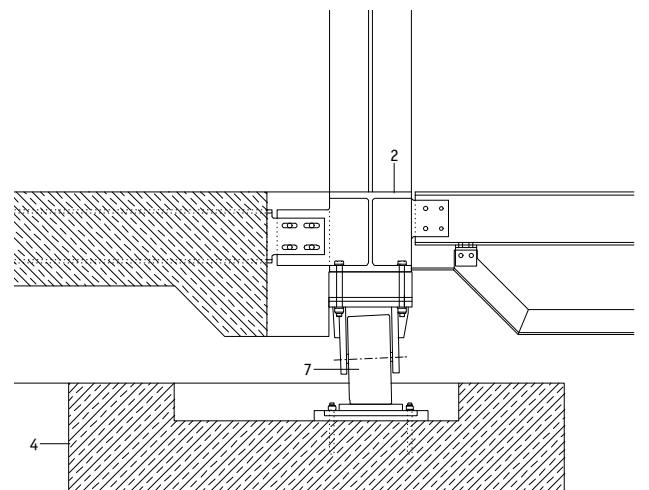

Wheel assembly, 1:35

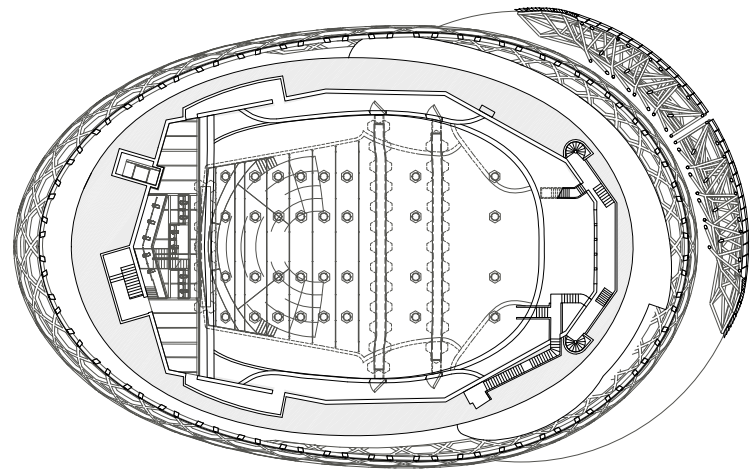

Floor plan of concert hall (not to scale)



## La Seine Musicale

Paris, France, 2017

Shigeru Ban Architects + Jean de Gastines Architectes

The 36,500 m<sup>2</sup> cultural centre for music is located on the Île Seguin island on the River Seine in Boulogne-Billancourt, a suburb southwest of the centre of Paris. The product of an international competition, the centre was built from 2014 to 2017 and is situated on the site of the former Renault factory that had occupied the island since the 1930s and brought prosperity to this outlying region of Paris.

The rounded, transparent glass skin of La Seine Musicale is held in place by a honeycomb-like structure of curved glulam beams and encloses a sheltered, light-filled microclimate in the interior. Alongside two large halls accommodating a total of more than

7,150 visitors, there are rehearsal rooms, recording studios, a music school, rooms for the orchestra musicians, and small shops and restaurants. The surrounding park creates an inviting entrance sequence. A sail comprising 870 m<sup>2</sup> of solar panels wraps around the front of the concert hall facade and follows the course of the sun. It shields the interior against heat and generates some of the energy for operating the building.

The approximately 38 m high sail is pneumatically mounted in a rail and travels a distance of about 100 m per day as it tracks the position of the sun to optimally align the photovoltaic modules. Conse-

quently, the sail makes it possible to supply approximately 65% of the building's energy demand through renewable energy.

The articulated pivot and upper bearing of the sail is located on the roof of the building and comprises an electrically operated turntable securely connected to the sail by a metal bar.



Rotating solar sail

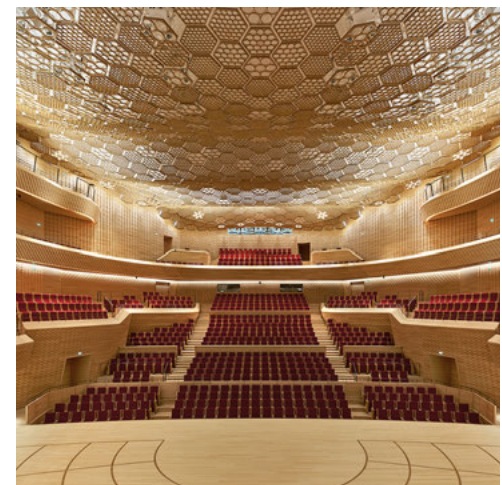

Interior of the concert hall

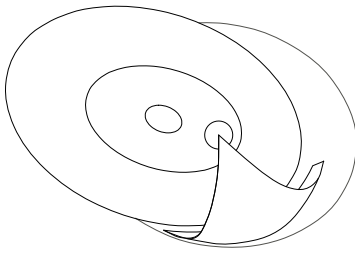

morning

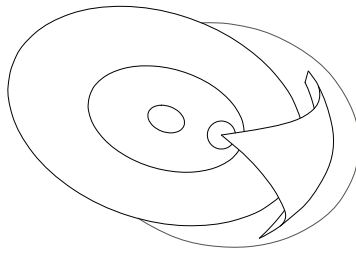

midday

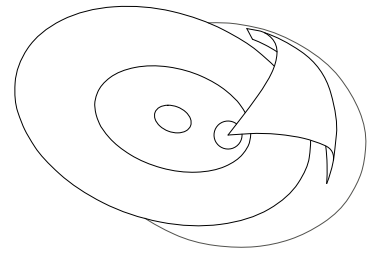

evening

**Dimensions** Height of the sail 37.70 m **Weight** 240 t

- 1 Pivot bearing
- 2 Connecting bar, steel
- 3 Trussed steel framework as supporting construction
- 4 Solar sail of photovoltaic cells
- 5 Loadbearing lattice structure of curved glulam beams with outer glazing
- 6 Travel rail and drive mechanism of the sail, pneumatically mounted

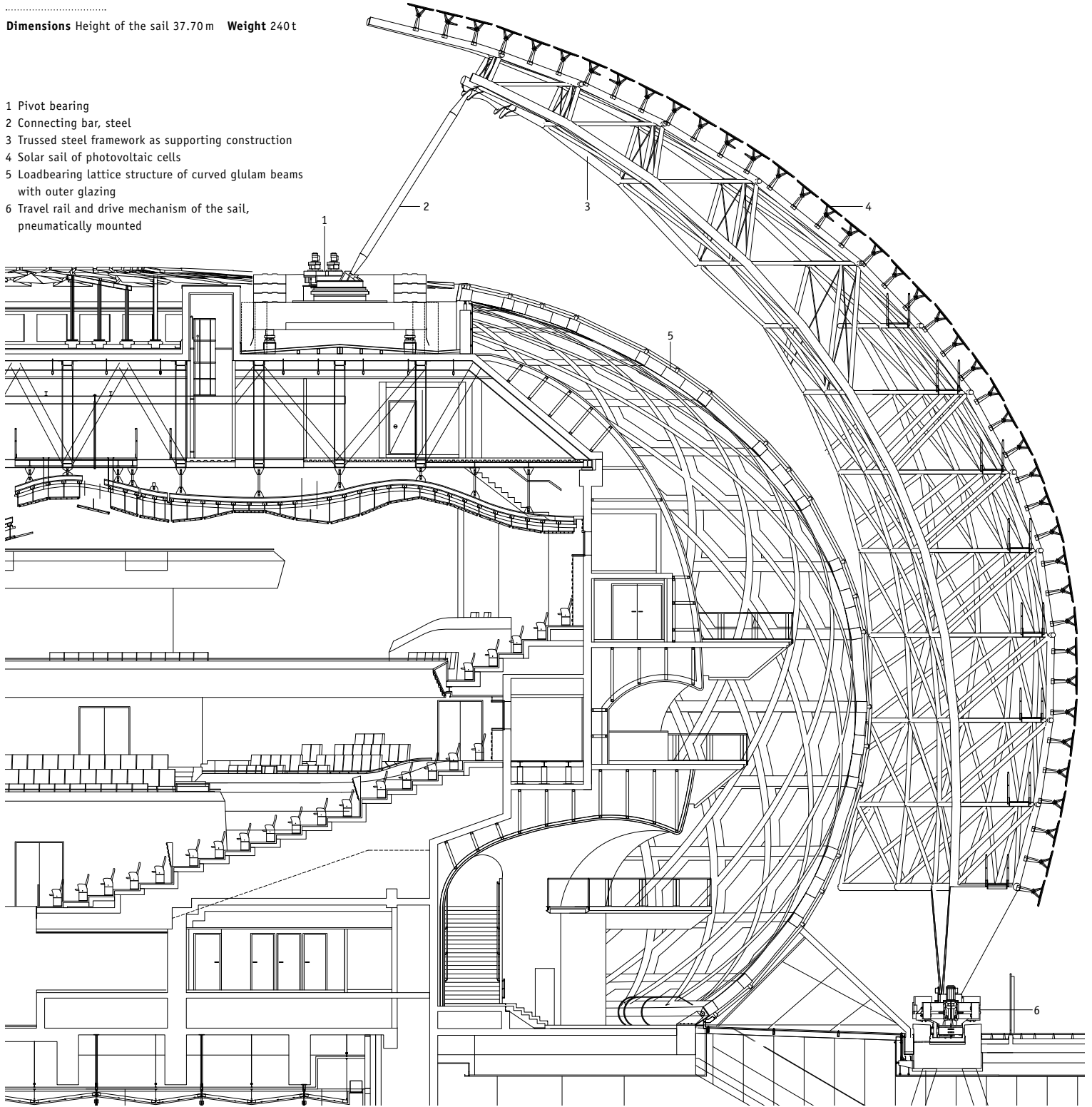

Section through building and rotating element, 1:200





Kinetic facade: metal panels with dancing metal discs



## Dancing Pavilion

Rio de Janeiro, Brazil, 2016  
Estudio Guto Requena

The dancing pavilion, designed for a Brazilian beer brand, is situated right in the heart of Barra Olympic Park in Rio de Janeiro, the main stadium site of the 2016 Olympic Games. The interactive installation is a product of ten years of ongoing research at Estudio Guto Requena at the intersection of technology, design and poetry.

Measuring  $30 \times 9.92 \times 7$  m, the pavilion encloses an area of approximately  $300 \text{ m}^2$ . A steel skeleton framework of hollow section profiles serves as the loadbearing structure. The lower third of the pavilion is completely open, while the upper part is clad with an external skin of metal panels. The reflective inner surface creates a uniform impression within,

while on the outside the pavilion shows a multi-coloured pattern of different colours and tones.

The external skin consists of 824 fixed, square metal panels, 345 of which have a movable panel in the middle. These round panels can turn about a single axis by  $365^\circ$  and can be opened and closed by swivelling them. Sensors in the dance floor capture the beat of the music and the movement of the dancers, and animation software converts these data into movement of the metal panels. The resulting optical play of light and shadow in the interior and around the pavilion creates a unique atmosphere.

Each element of the external skin measures  $87 \times 87$  cm and comprises a frame of rectangular

hollow-section steel profiles with an outer facing of coloured metal sheeting and a mirrored inner surface. The elements with a moving element have an additional small stepper motor, axle and a 60 cm diameter metal disc. The movable panel is attached to the axle, which is rotated by pulleys and a belt by means of a small motor.

The hardware and software that dynamically animate the kinetic facade in response to data from sensors in the dance floor was developed together with the digital developers estudio D3.



Facade with closed and open panels

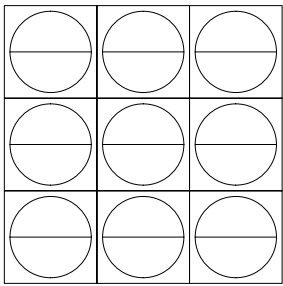

0:00

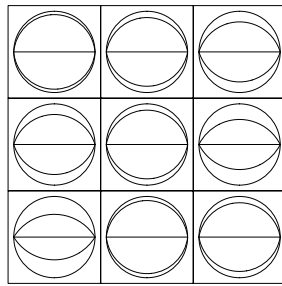

0:30

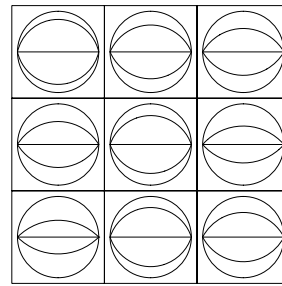

1:00

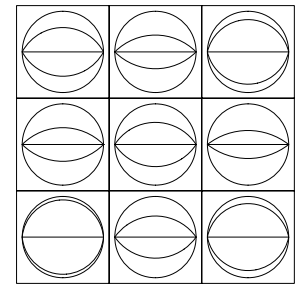

1:30

sec

.....  
**Dimensions** L × H = 0.87 × 0.87 m **Number** 345 modules **Weight per element** 4.2 kg/module

- 1 Hollow-section steel profile
- 2 Aluminium composite skin
- 3 Aluminium composite rotating panel
- 4 Steel disc welded to axis
- 5 Rotating bearing
- 6 Pulleys
- 7 Drive belt
- 8 Motor
- 9 Control unit / hardware case

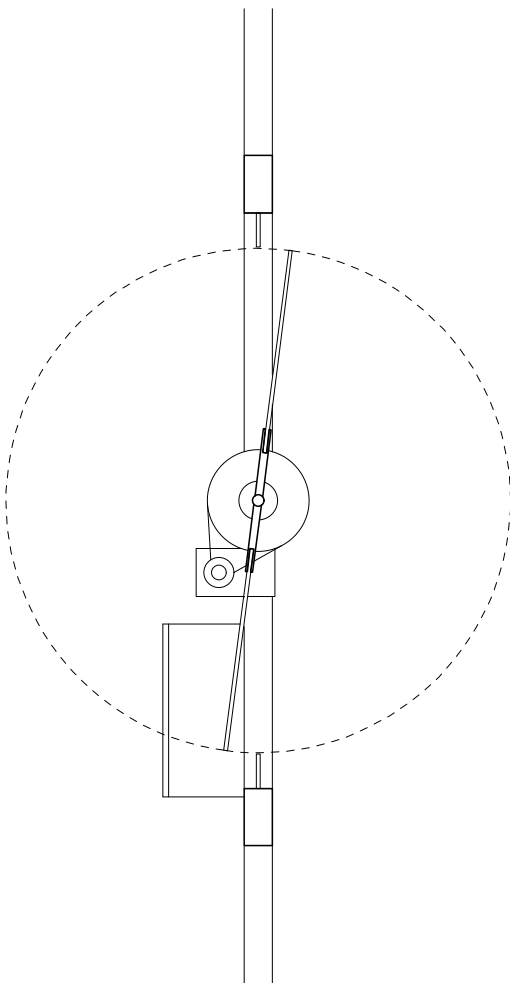

Vertical section, 1:10

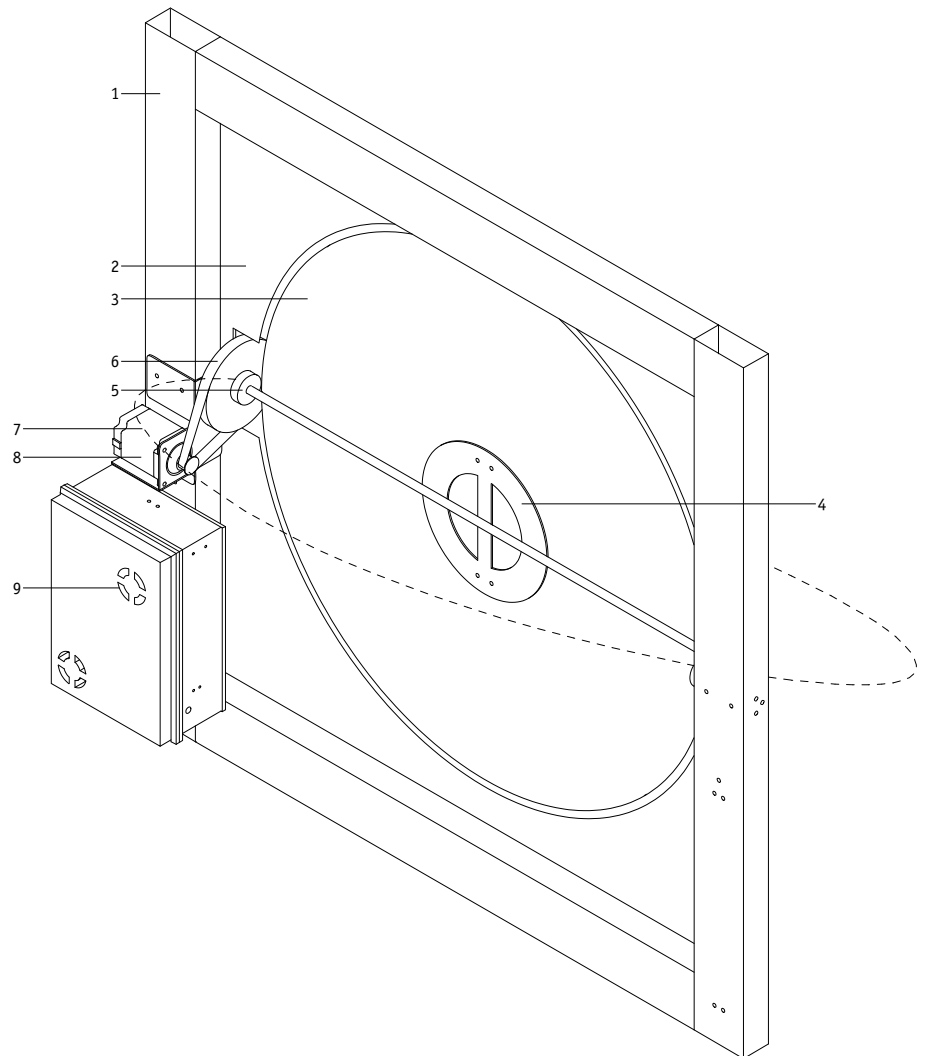

Axonometric projection of an element, 1:10

Rotate



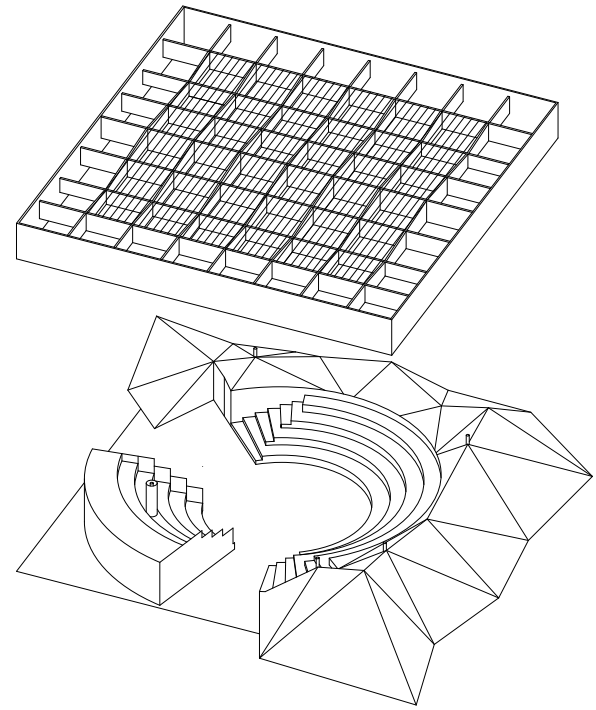

## MPavilion 2017

Melbourne, Australia, 2017  
Office for Metropolitan Architecture (OMA)

Axonometric projection of artificial earth mound and amphitheatre with both grandstand elements

The 2017 MPavilion was the fourth pavilion to be erected in the Queen Victoria Gardens in Melbourne's Southbank Arts Precinct as part of an annual architectural event. Today it stands on the Clayton Campus of Monash University in a suburb of Melbourne. As a public space, the pavilion provides an opportunity for interaction, performances and events on the theme of architecture, design and culture.

Two grandstand elements form an amphitheatre and together surround a freely configurable space in the centre. The entire pavilion is covered by a square,

2 m high, open grid roof structure supported at only a few specific points. The larger grandstand element is clad with plywood and describes a semicircle. Firmly anchored to the ground, it is partly embedded in an artificial mound of earth with triangulated surfaces planted with twelve different Australian grasses.

The smaller grandstand element is a quarter circle and can rotate to form different spatial stage constellations. When facing the central stage, it completes the circle of the theatre, when turned by

180°, its rear wall serves as the backdrop for the stage.

The underlying structure is a lightweight framework of hollow square-section steel members clad with perforated metal sheeting. One of the supports for the grid framework of the roof serves as the pivotal axis. The grandstand rests on five castors, which are height-adjustable to accommodate the slight gradient of the ground. The grandstand is turned manually, and two people are required to rotate it.



View of interior



View from outside showing moving element

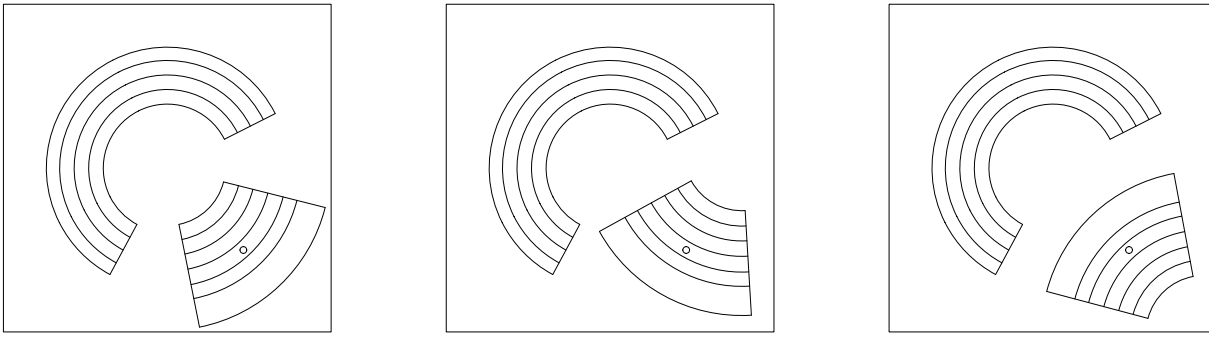

Dimensions L x H = 5.50 x 2.30 m Number 1 Drive Manual

- 1 Mounting plate, 10 mm
- 2 Steel column, Ø 500 mm
- 3 Circular swivel bearing
- 4 Hollow square-section steel profiles
- 5 Height adjuster

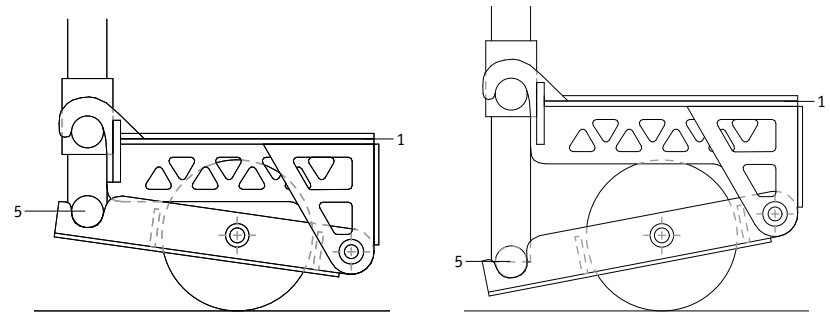

Detail of height-adjustable castor, 1:10

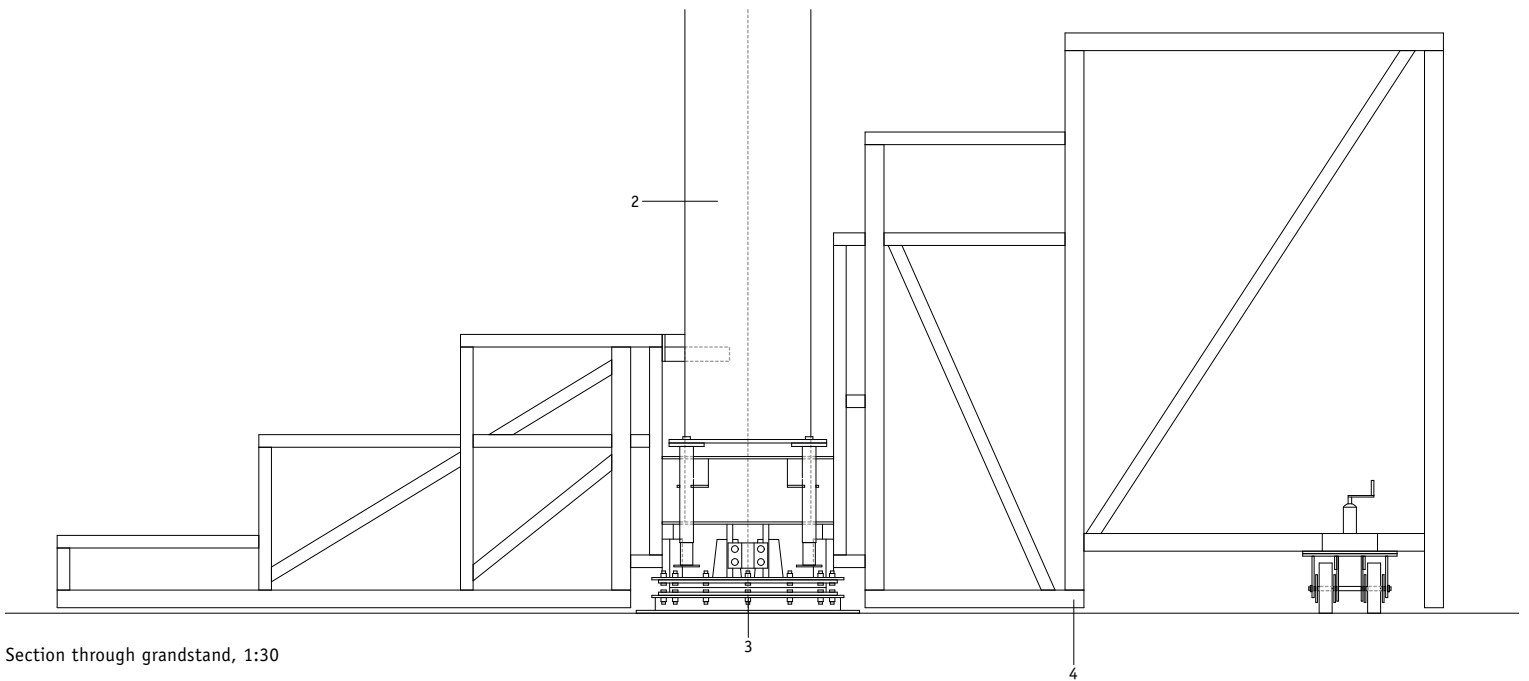

Section through grandstand, 1:30

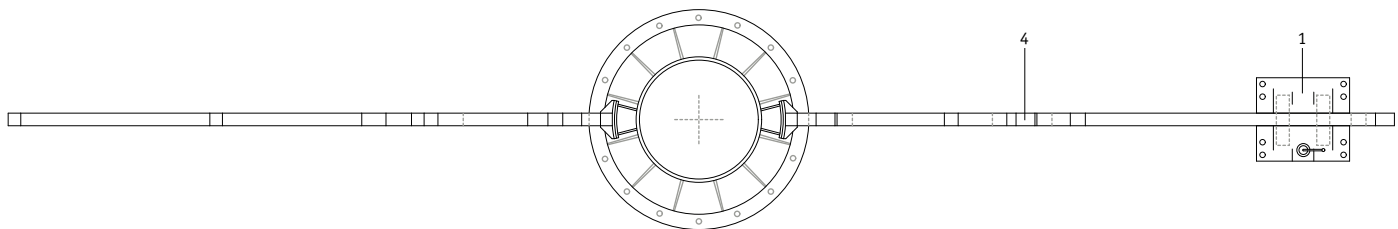

Floor plan of grandstand, 1:30

Rotate





Observatory with two telescope turrets



## Kielder Observatory

Northumberland, UK, 2008  
Charles Barclay Architects

This astronomical observatory is located in the wild landscape of Northumberland, near to the Scottish border, in one of the least light-polluted areas of England. The building, which is the product of an international architecture competition, has been acclaimed by architectural critics, winning awards from the RIBA, the Civic Trust, and the Hadrian Awards.

The raised elongated bar of the observatory mediates between the forest landscape and Kielder Water, and houses two telescopes along with a heatable “warm room” for presentations and training. Arranged behind the “warm room” with its cantile-

vered flat roof are two turrets housing telescopes separated by an observation deck.

The low-tech appearance of the architecture responds to the rugged location and was accordingly hand-made on site using traditional building techniques. The loadbearing structure, support columns of the telescope, facade cladding and finishes are all made of wood, with only the bracing elements, the shutters and the mechanical elements of the telescope turrets made of steel.

The rotating telescope turrets are constructed as steel octagons and have eight wheels that rest on a circular rail mounted on a second stationary steel

octagon in the lower part of the tower. The driving mechanism is a rack and pinion mechanism operated manually using a large stainless steel wheel and handle. A system of gears ensures that a person can provide sufficient torque to move the 6 t towers. The telescopes are mounted on concrete-filled tubular steel columns that are physically separated from the wooden structure to ensure they are unaffected by vibrations.



Open telescope turret from outside



Open turret from inside with telescope

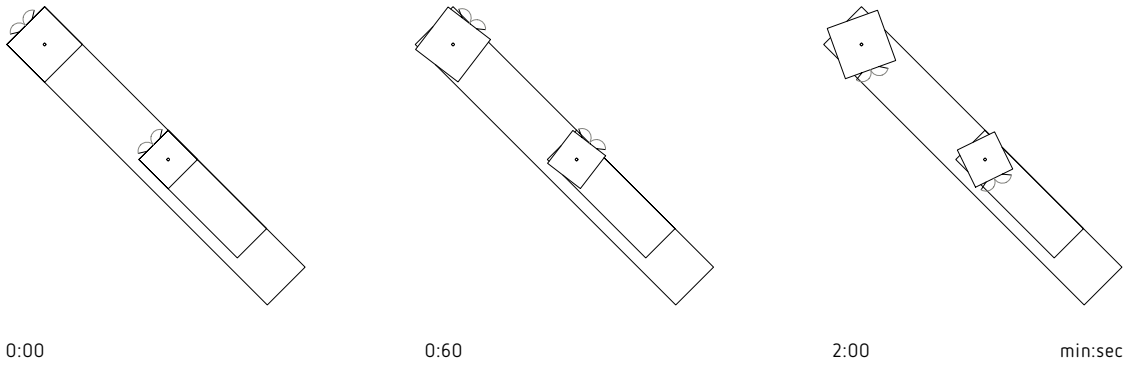

Dimensions L x W x H = Turret 1: 5.20 x 5.20 x 1.50 m, Turret 2: 4 x 4 x 1.20 m Number 2 Weight per element 4t and 6t Drive Manual

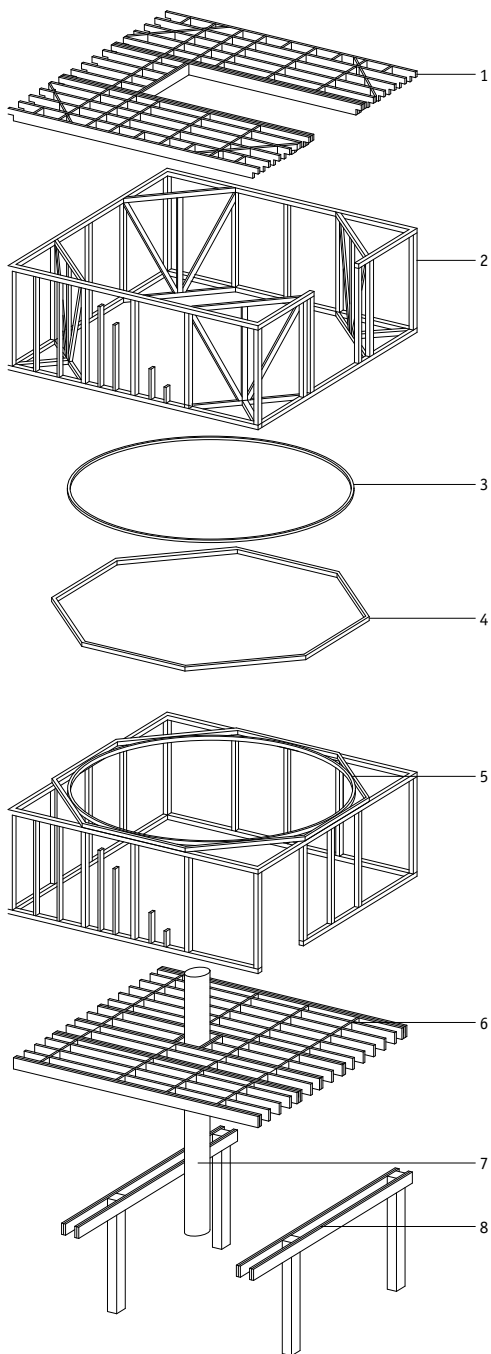

Exploded view (not to scale)

- 1 Roof structure, framed timber construction
- 2 Turret structure, timber frame
- 3 Radial rack, stainless steel
- 4 Octagonal hollow-section profiles, steel
- 5 Guide rail
- 6 Floor, framed timber construction
- 7 Steel support column for telescope
- 8 Cantilevered sub-frame, Douglas fir
- 9 Flanged wheel
- 10 Gear wheel
- 11 Wind-handle, stainless steel
- 12 Bevel gear

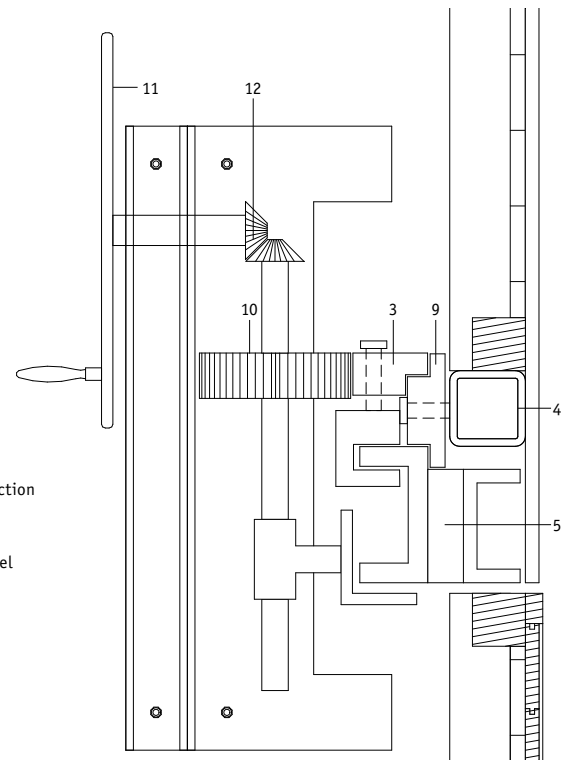

Sectional elevation of drive mechanism, 1:10



Drive: hand-operated wheel with geared cogwheel and radial rack

Rotate





External view at night



## Piscine Tournesol

Lingolsheim, France, 2014  
Urbane Kultur Architectes

The Piscine Tournesol swimming pool was designed and built in the 1970s by architect Bernard Schoeller. The building's rigorously rational structural concept gives the interior a distinctive atmosphere that comes alive through the play of light and the relationship between indoors and outdoors. Its large sliding wall sections and elegant construction contribute to the special character of the complex. The renovation and extension of the building aimed to restore the simple clarity of the original design. Alterations made over the years were removed to restore the integrity of the interior. The changing

rooms, entrance hall, admin offices and plant rooms were relocated into a separate extension. A metal dome now spans the 1,790 m<sup>2</sup> large interior and its three stainless steel pools. It protects against the weather while allowing daylight into the interior via an array of round skylights. Three quarters of the dome are fixed in place while the remaining quarter is divided into two movable sections that can slide sideways. The two opening sections follow the shallow arc of the dome like a second skin resting on the dome and can be pushed open on both sides like a large portal.

The metal doors are held in place at the top and bottom and travel along metal guide rails using a system of rollers.



Open roof from outside



Interior with open roof

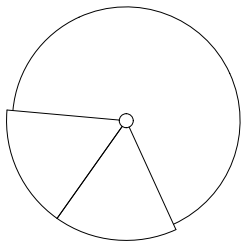

3:00

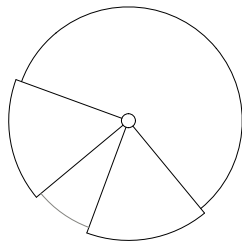

6:00

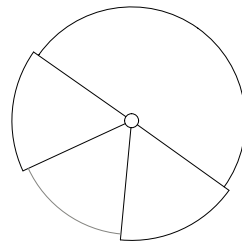

9:00

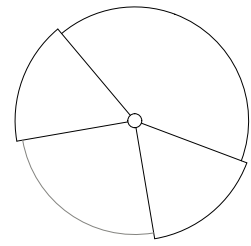

12:00

min:sec

Dimensions R = 28 m, H = 12 m Number 2 Drive Motorised: electric engine, rail and chain

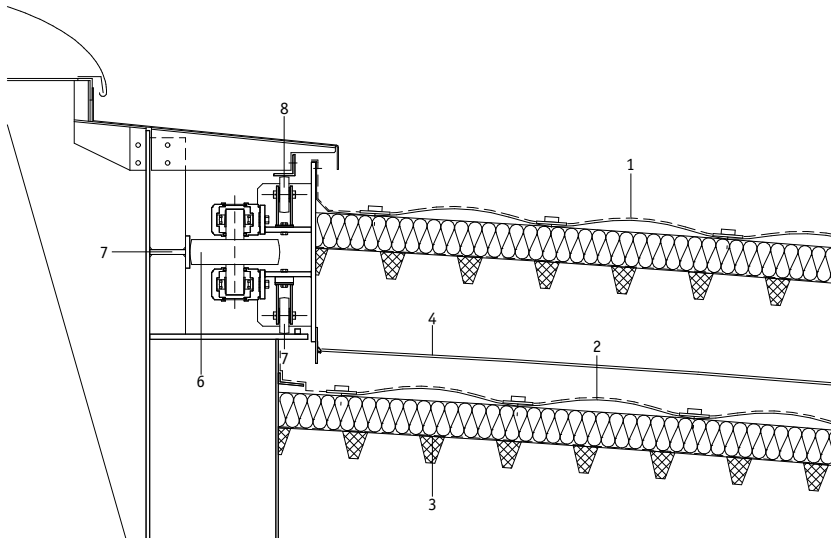

Detail of roof junction, 1:33

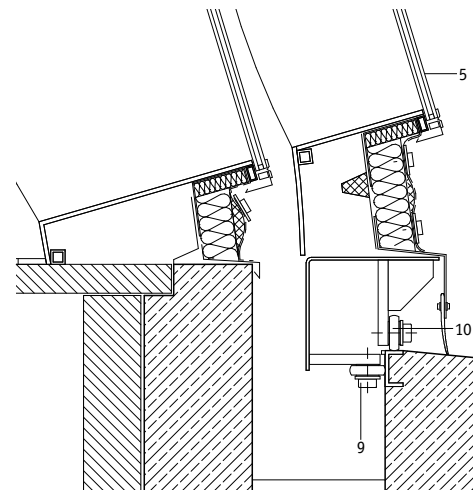

Detail of base junction, 1:33

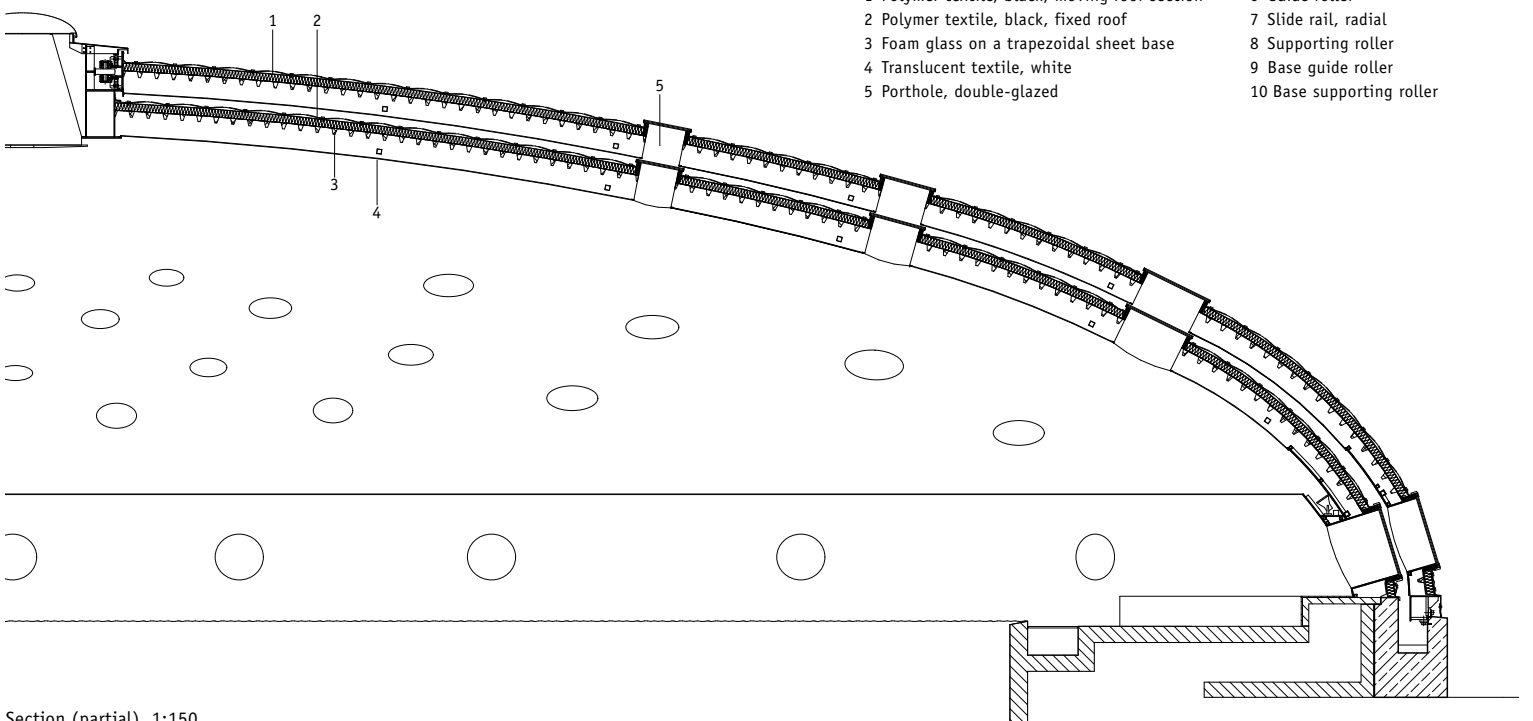

Section (partial), 1:150

- |   |                           |
|---|---------------------------|
| 1 Polymer textile, black, moving roof section | 6 Guide roller            |
| 2 Polymer textile, black, fixed roof          | 7 Slide rail, radial      |
| 3 Foam glass on a trapezoidal sheet base      | 8 Supporting roller       |
| 4 Translucent textile, white                  | 9 Base guide roller       |
| 5 Porthole, double-glazed                     | 10 Base supporting roller |

Rotate



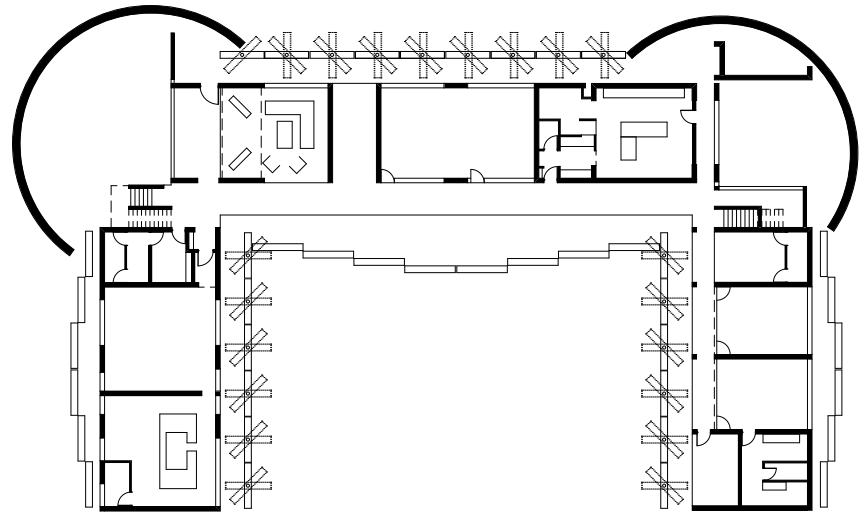

Floor plan (not to scale)



## Moving Landscapes

Ahmedabad, India, 2012  
Matharoo Associates

Situated on the outskirts of Ahmedabad, the 1,900 m<sup>2</sup> house was designed to accommodate one of the city's most prolific property developers and his wife, along with his two sons' families and other visiting guests. The floor plan of the house is conceived as a linear pavilion, allowing each room to be glazed on both sides. Loadbearing 200 mm thick concrete walls and slabs eliminate the need for beams and columns in order to create continuous interior spaces.

The second shell of the building is comprised of solid 4.50 m high and 3 m wide walls clad in Bidaser marble that surround the entire building but are movable. Mounted on a steel substructure, they slide back and forth on one side of the building and rotate about their central axis on the other. This movable construction presents several advantages. On the one hand, the space between the two building envelopes is used as passageways, verandah, entrance anteroom and circulation area, reduc-

ing the air-conditioned area and creating a buffer between inside and outside. On the other, it shields the large glazed surfaces from rain as well as from intense sunlight and outdoor temperatures of up to 45°C, providing weather and privacy control whenever desired. Through the layering of spaces and screens, the building envelope becomes an interface mediating between the high-quality interiors and the verdant outside space.



Facade in motion



Rotated marble walls

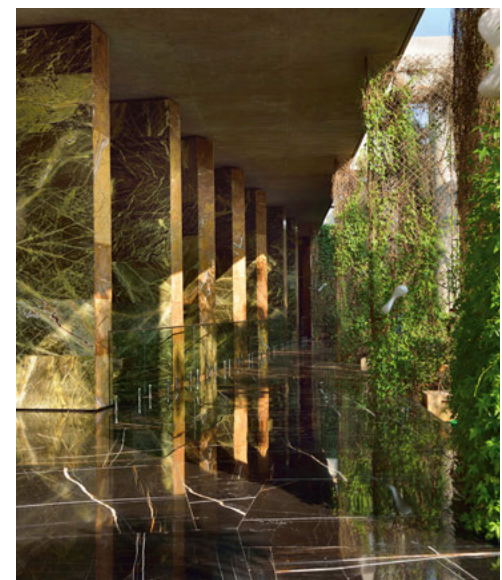

Moving elements seen from inside

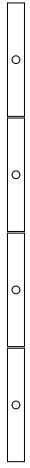

0:00

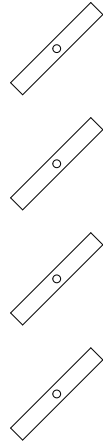

0:10

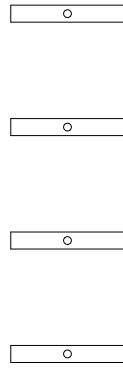

0:20

min:sec

Dimensions  $L \times W \times H = 3 \times 0.45 \times 4.50$  m Number 21

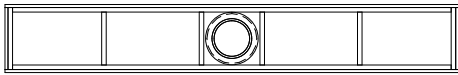

Horizontal section, 1:5

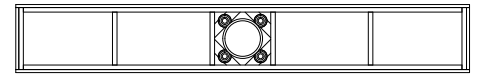
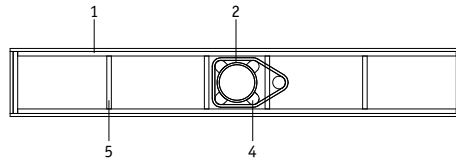

- 1 Marble panels, 15 mm
- 2 Steel column,  $\varnothing$  250 mm
- 3 Motor
- 4 Guide rollers for belt drive
- 5 Steel construction
- 6 Element coupling with steel cables



Steel cable connecting the building elements

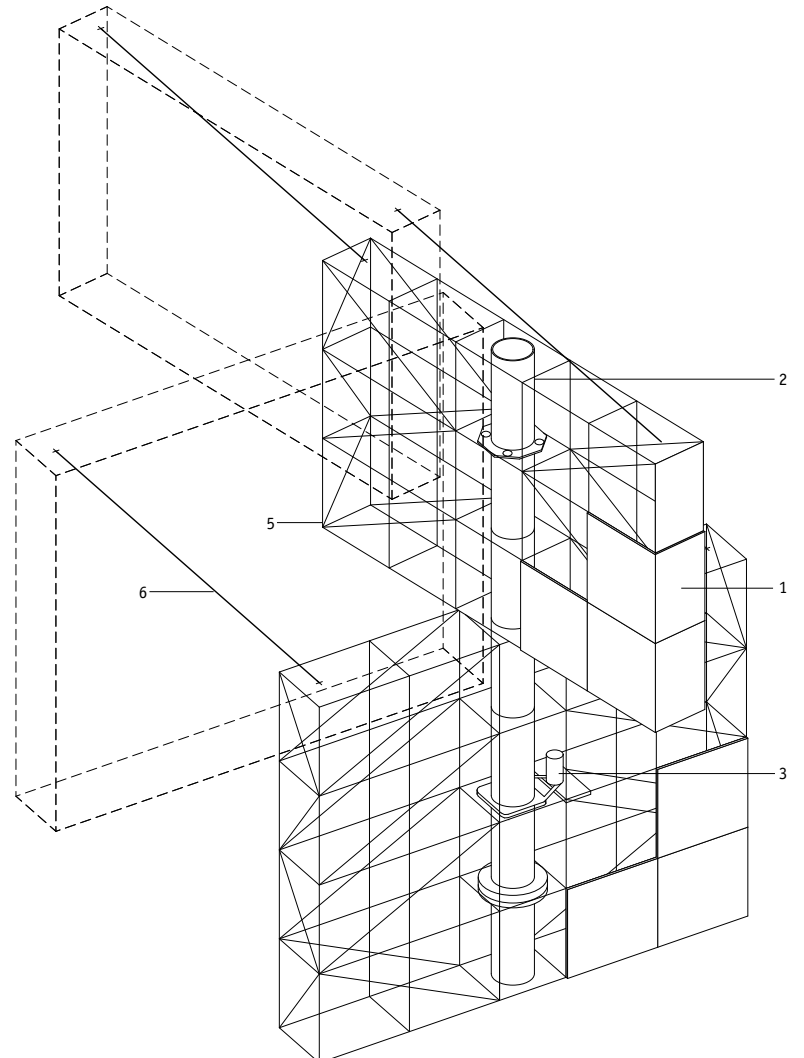

Axonometric projection of an individual element

Rotate



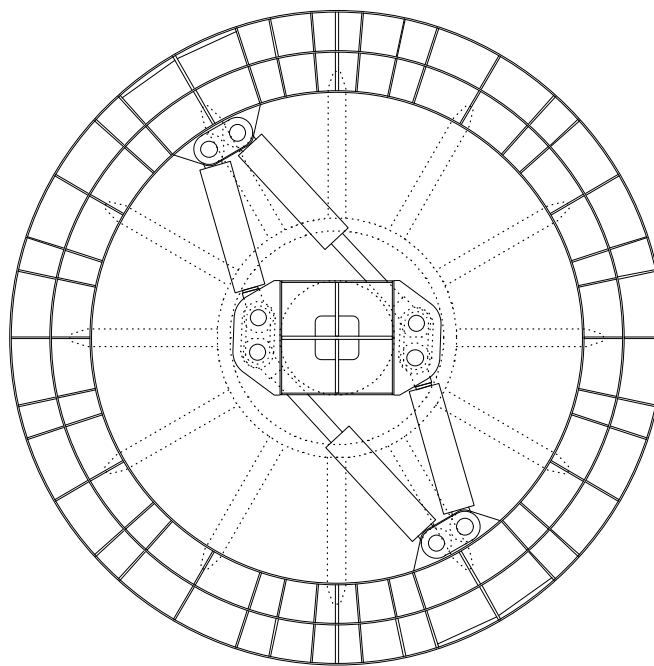

Underside of the pivot mechanism with hydraulic cylinders and central sliding bearing

## Odins Bro

Odense, Denmark, 2014  
 ISC Consulting Engineers A/S  
 with Bystrup Arkitekter og Designere

In September 2009, ISC Consulting Engineers A/S won the international design competition for the 900 m long Odins Bro. Part of the new ring road around Odense on the Danish island of Funen, it connects the two banks of the Odense canal for car, bicycle and pedestrian traffic. The central element of this connection is a 194 m long double swing bridge, the longest of its kind in Europe, with a mean centre span of 120 m and side spans of 37 m each. In 2013, the bridge was awarded the Prize of the International Association for Bridge and Structural Engineering and, in 2016, the European Steel Bridge Award.

The main structure is a steel box girder bridge with a distance of 3 m between the box girders. The loads of the two bridge halves are transferred to the bearing points via 20 m high pylon structures. To permit boats to pass unhindered along the canal, the two halves of the bridge can be rotated synchronously about their central pivot points on the banks. Each bearing point on either side of the canal comprises a steel box ring with a diameter of 12 m that rests on a reinforced concrete ring of the same size. These carry two permanent sliding bearings and two further bearings, which are only jacked up beneath the bridge during rotation to secure stability while

the bridge is moving. Supports centred beneath the pylons sustain the majority of the load via a further bearing.

The bridge halves are each moved by four hydraulic cylinders. When the bridge is closed, the two elements align in the same direction and are connected by shear bars at the centre of the bridge. Hydraulic shear bearings at the end abutments secure the bridge in position.

The engineers have designed the bridge for a service life of 100 years.



Bridge open and closed



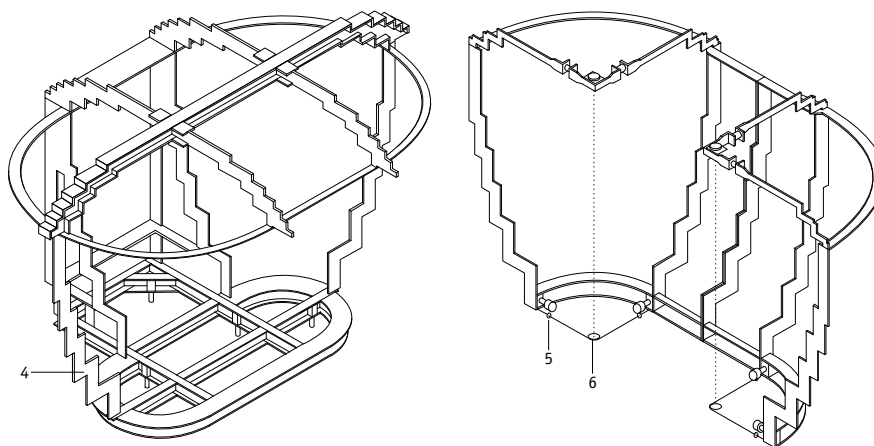

Axonometric of loadbearing steel framework

## Paperhouse

London, UK, 2009  
Heatherwick Studio

Under the name Paperhouse, Heatherwick Studio developed several newspaper kiosks for the London borough of Kensington and Chelsea. The previous kiosks with roller shutters were unwelcoming and faceless when closed and were frequently graffitied. The aim of the project was to make their opening simpler and quicker for the vendor and to curb vandalism.

The Paperhouse has an oval floor plan with external dimensions of approximately  $4.50 \times 3$  m. The volume tapers from top to bottom in a succession of tiers, giving it a sculptural appearance. On the inside, the facade elements serve as display shelves for the

magazines, while on the outside, the patinated brass cladding lends the kiosks a touch of class and quality. A glazed strip beneath the roof allows daylight into the kiosk.

The kiosks are opened by sliding the two front sections to either side around the curved exterior, a process that is easier for the kiosk sellers to operate than a conventional roller shutter. In addition, the magazine racks no longer need to be emptied every evening as they can remain inside the sliding elements.

The kiosks and their opening elements are made of a steel skeleton of CNC-milled 130 mm deep vertical

ribs of steel flats. These are welded at the bottom to I-beams, which follow the oval shape of the kiosks and at the same time serve as guide rails for the four nylon rollers per opening section. The rollable opening elements are attached via adjustable fixings to the static steel frame at the pivot point. Six adjustable legs ensure the kiosk can stand level on uneven ground. The kiosks were factory assembled and installed on site in just 12 weeks.



Opening sequence

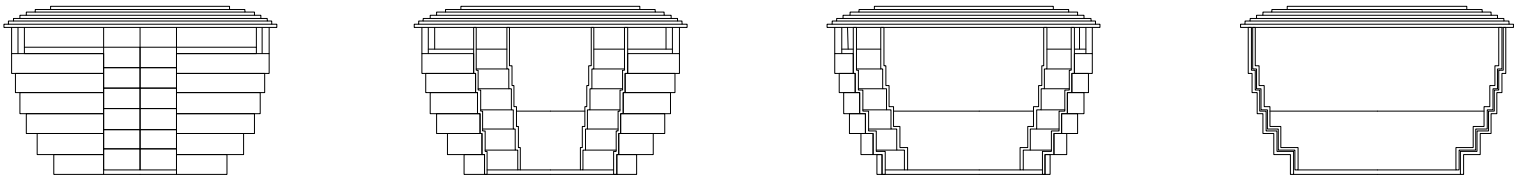

.....  
**Dimensions** L x W = 4.50 x 3 m **Number** 2 **Weight per element** 2.25 t including ballast weight **Drive** Manual

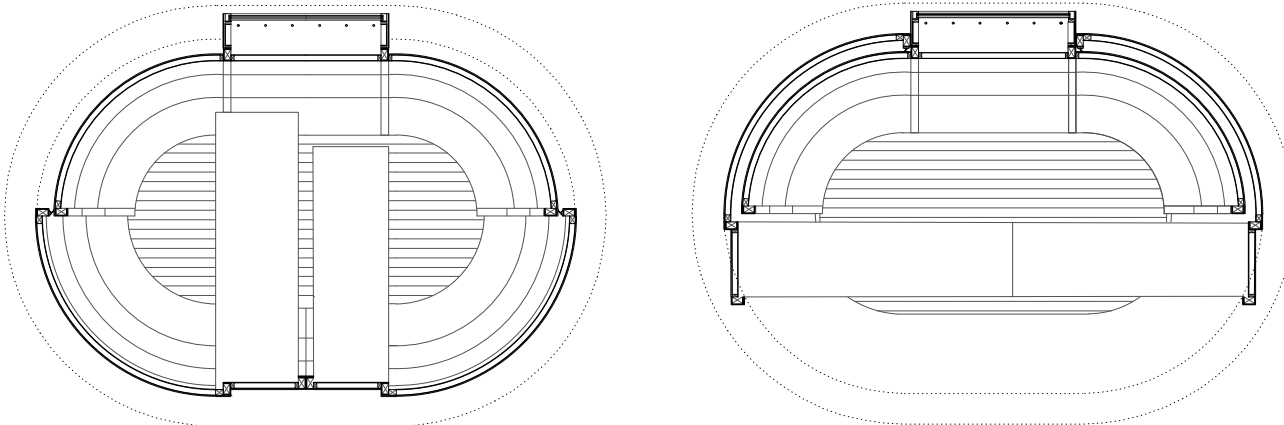

Horizontal sections, closed and open, 1:50

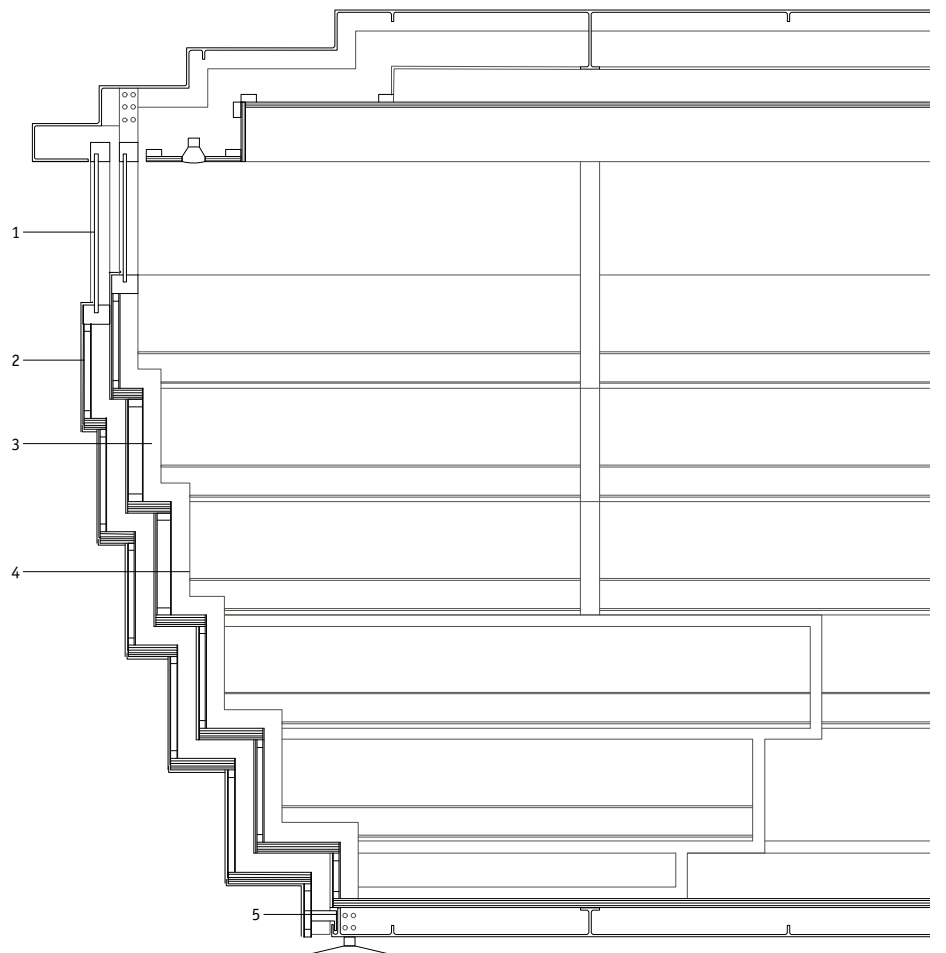

- 1 Clerestory glazing, safety glass
- 2 Patinated brass bands mounted on sheet steel plates
- 3 Internal cladding, plywood
- 4 Profiled steel ribs, CNC milled
- 5 Nylon roller in I-beam channel

Section, 1:20



Vehicle interior as living room furniture

## Renault Symbioz House 33

France, 2017  
Marchi Architectes

The Renault Symbioz House 33 was developed as a mobile showroom for Renault's vision of the role of the car in the future in which digital car electronics and smart home systems are linked and the car becomes an extension of the living space.

The pavilion consists of two stacked volumes. The lower part has an open, rectangular floor plan of approximately 21 × 6 m and is open, not only inside, but also to the outside through floor-to-ceiling glazing. The car can drive directly into the living space and, like the house, is comfortably equipped in its interior.

The upper floor appears as an opaque cylindrical form and vehicle each pass over a pair of steel pulleys suspended from the steel beams of the roof to the laterally positioned winch. Two guide rails stabilise the position of the platform during movement. Since the showroom had to be erected and dismantled at different locations, the designers opted for a lightweight, raised steel skeleton construction. The dimensions of the individual elements were chosen so that they could be optimally transported in shipping containers.

The motor and winch are located on the upper floor. The four 1 cm thick steel cables that raise the plat-

form and vehicle each pass over a pair of steel pulleys suspended from the steel beams of the roof to the laterally positioned winch. Two guide rails stabilise the position of the platform during movement. Since the showroom had to be erected and dismantled at different locations, the designers opted for a lightweight, raised steel skeleton construction. The dimensions of the individual elements were chosen so that they could be optimally transported in shipping containers.



Platform in motion

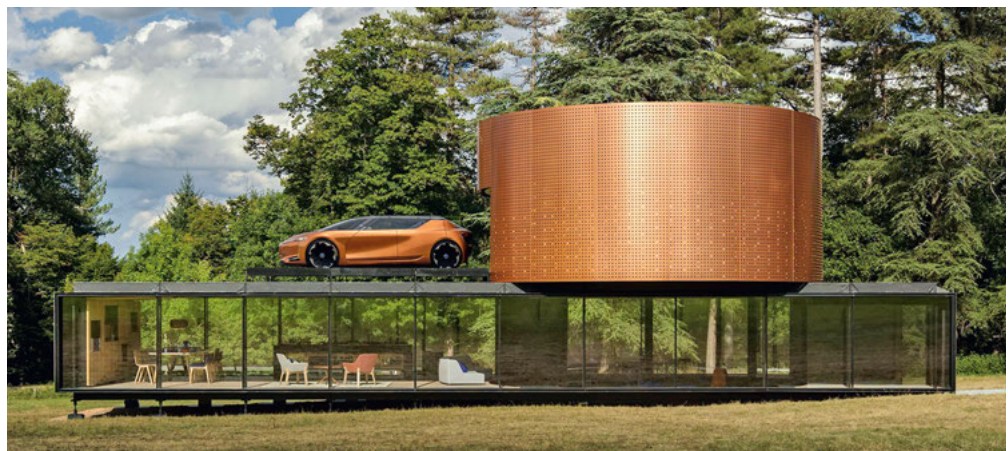

Exterior view with raised platform

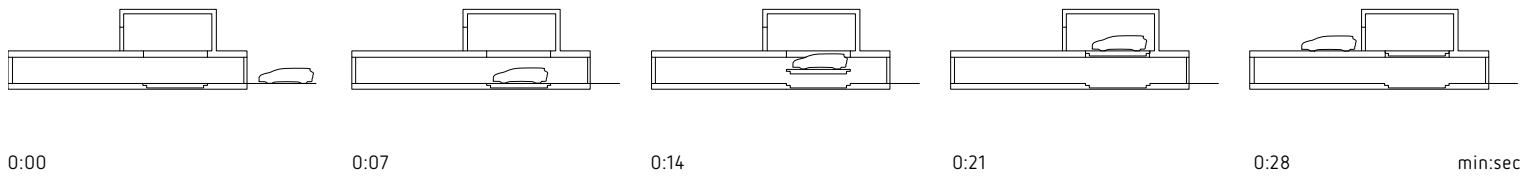

.....  
**Dimensions** Platform  $\varnothing$  5.70 m **Number 1** **Weight** 2,900 kg + 2,240 kg loadbearing capacity

- 1 Pulley, steel,  $\varnothing$  30 cm
- 2 Steel cables,  $\varnothing$  13 mm
- 3 Guide rails
- 4 Outer ring of lift platform, steel, 350 x 100 mm
- 5 Rotating turntable within the lift platform, timber decking, 25 mm
- 6 Drive, two gear motors and winches

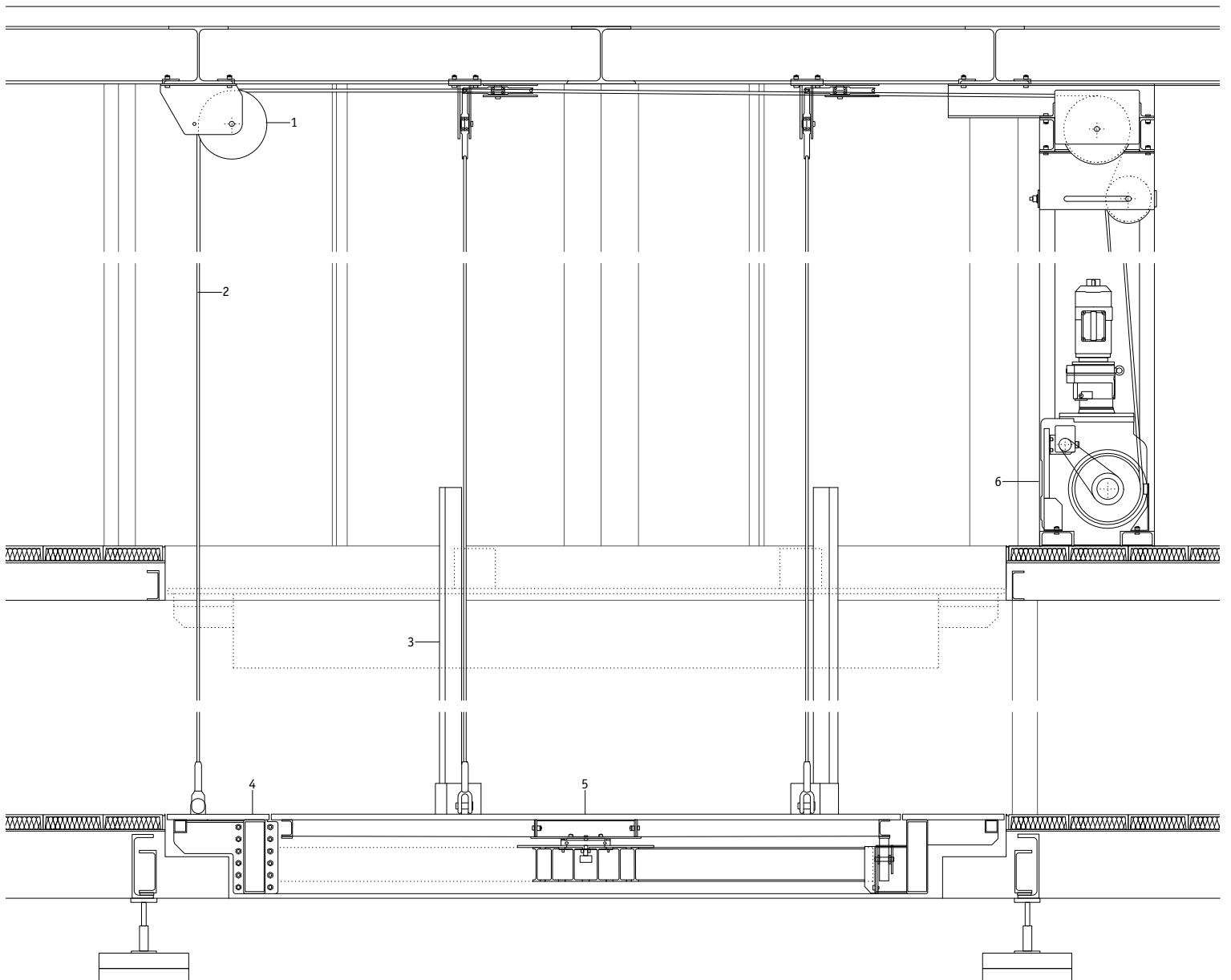

Cross section through platform, 1:50

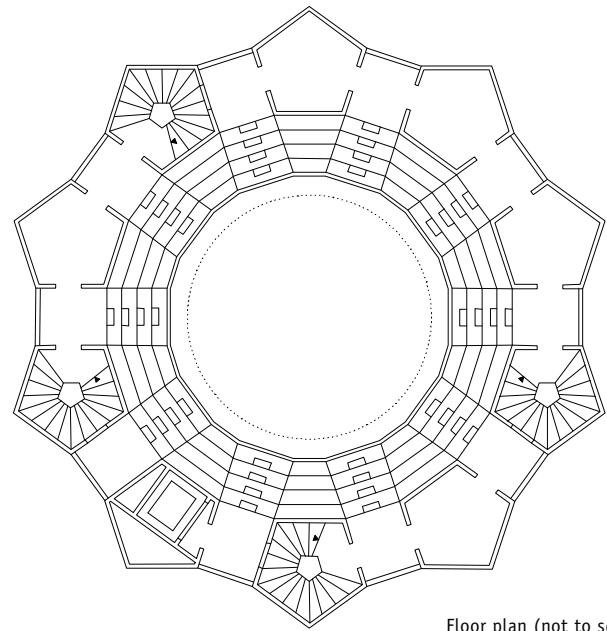

Floor plan (not to scale)

## Theatre Tower on the Julier Pass

Graubünden, Switzerland, 2017  
Giovanni Netzer, Walter Bieler

The Julier Theatre Tower on the Julier Pass is a temporary theatre tower situated at an altitude of 2,300m in the Swiss Alps. As the venue and main landmark of the Origen cultural festival in the canton of Graubünden, the tower is intended to attract visitors. The director of the festival, Giovanni Netzer, designed the tower in collaboration with the engineering office of Walter Bieler.

The 30m high tower has an abstract, star-shaped floor plan and is visible from afar thanks to its striking red colour. All the openings have the same rounded arched top, which contributes to its archaic impression. The weather, time of day and landscape are always apparent through the openings

and the actions on stage also make reference to them.

The vertically organised theatre building contains a round, central atrium that extends across the entire height of the tower, with the seating arranged around it on five floors. In the centre of the atrium is a circular 8m diameter platform that serves as a stage and can ascend and descend to play to all spectator levels.

The structure consists of star-shaped arrangement of ten pillars made of 12cm thick glulam elements that serve as the loadbearing and bracing structure and also contain within them the staircase and elevator cores. Open theatre boxes are arranged

between and in front of them. The tower was factory prefabricated in 40 separate parts and then assembled on site in two months. Only the foundation on which the 490t tower rests was cast in reinforced concrete on site.

The mobile platform is a construction of I-beam girders with a floor of cross-laminated timber panels. A motorised chain hoist suspended from the roof carries and moves the platform. In the centre of the platform is a separate insert that can be removed and replaced with a railing to create a ring-shaped stage.

The Theatre Tower will be used until 2020 and then dismantled.



The Theatre Tower from outside



View inside the tower looking down



Height-adjustable platform

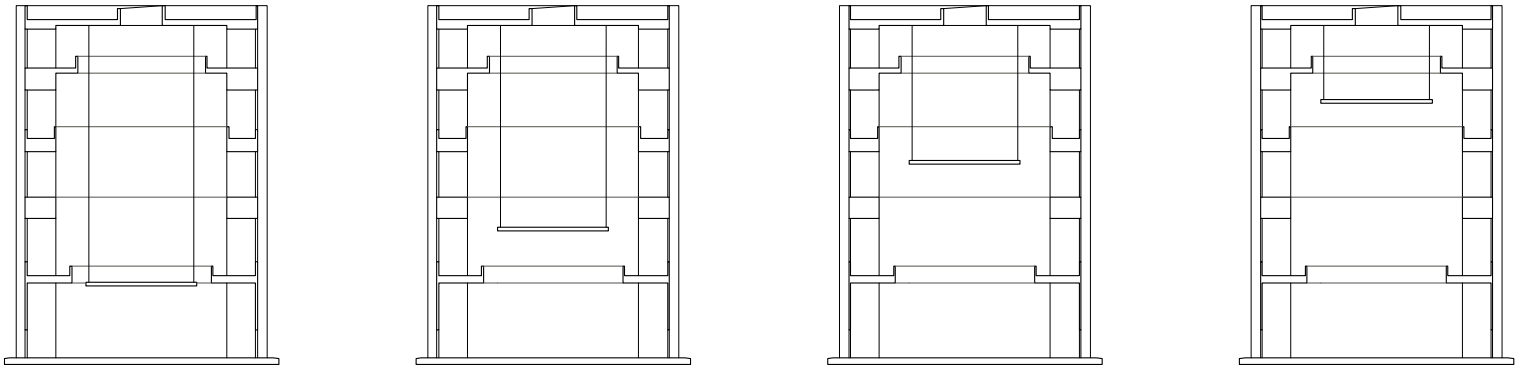

.....  
**Dimensions** Platform Ø 8 m **Number 1** **Weight** Stage 27 kN self-weight, 63 kN load capacity, total 90 kN = approx. 18 kN/chain hoist **Drive** Manual

Mounting position: standard hoist

- 1 Chain hoist with hook suspension
- 2 Chain with chain bag
- 3 Latch
- 4 Cross-laminated timber deck, 27 mm
- 5 Platform framework of I-beam girders
- 6 Central removable insert, replaceable with a balustrade railing

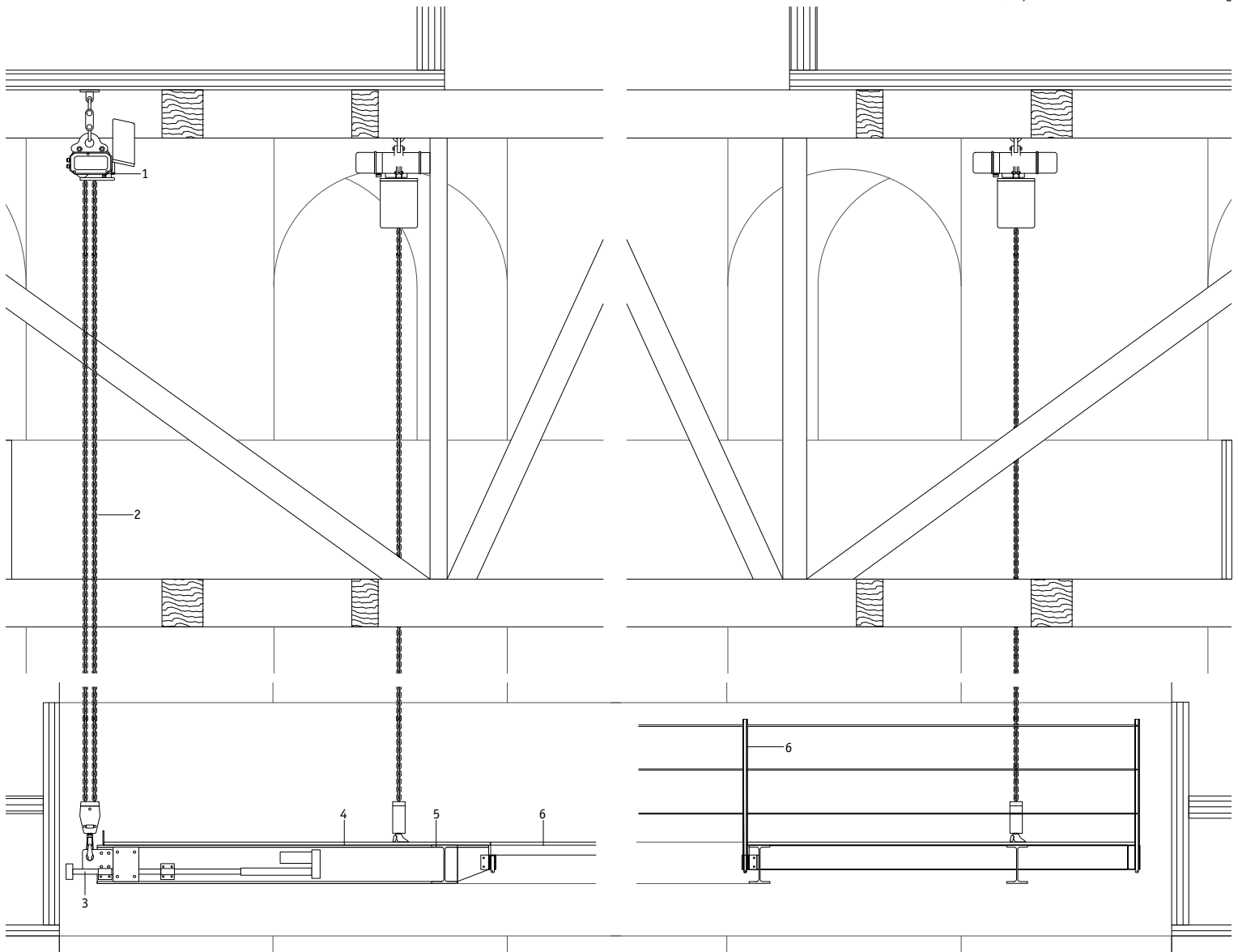

Section through the mobile stage platform and its suspension from the roof, 1:50

Slide



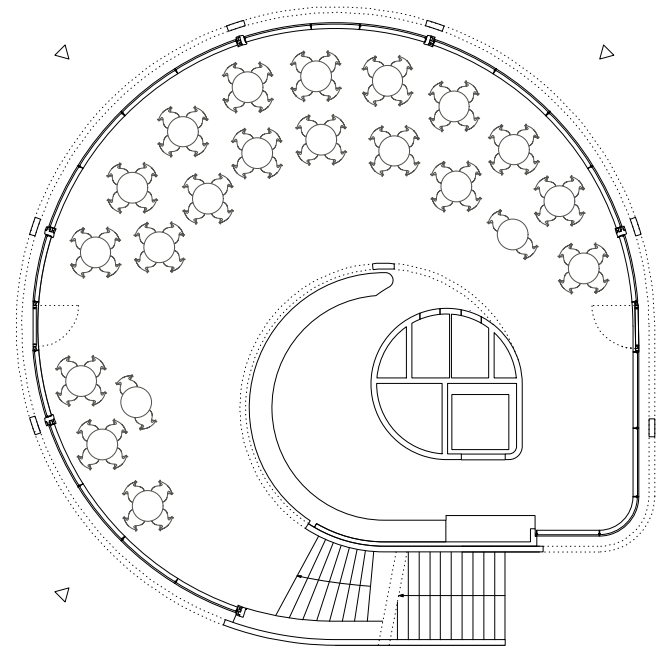

Floor plan with three lowerable window fronts (not to scale)

## Duke of York Restaurant

London, UK, 2019  
NEX-Architecture

The café and restaurant on Duke of York Square in London's Chelsea district is the product of an architectural competition for a site next to the historical 19th-century barracks. The structure of the single-storey café is spiral-shaped and has a diameter of approximately 16.80 m. The kitchen, toilets and ancillary spaces were placed in the basement to enable the café on the ground floor to be completely open and free of intrusive room functions. The spiral form of the building element is picked up by an external staircase leading to a planted public roof terrace and provides a panoramic view of the square. The basement staircase is located directly beneath it.

The impression of openness is reinforced by three curved, 3 m high glazing elements in the post-and-beam facade. In good weather, these sections can be fully lowered into the basement so that the square and the café blend seamlessly into one another. Even when closed, the horizontal members of the retractable glazing are concealed by the floor and ceiling, creating the impression of an all-glass facade with an apparently uninterrupted transition between inside and outside.

The outer facade and core of the building are made of prefabricated white-coloured concrete elements assembled on site. Immediately behind this load-bearing plane lies the glass facade, which runs

almost 360° around the building, and has alternating fixed and lowerable sections.

The guide rails for the retractable window sections are located below ground. A motor beneath the floor moves the windows with a simple winch drive via two deflection rollers and a counterweight. The windows are held in position laterally by heavy-duty rollers running in stainless steel rails on the facade supports. For safety reasons, the raising and lowering mechanism is operated using a dead man's switch: movement only takes place while the button is depressed. As soon as the button is released, the drive cuts off, stopping movement immediately in the event of an emergency.



Bird's eye perspective



Front view

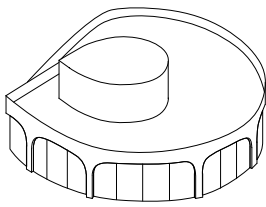

0:00

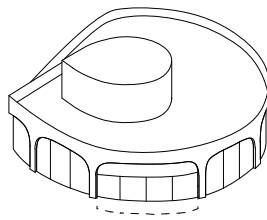

0:11

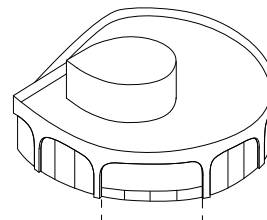

0:22

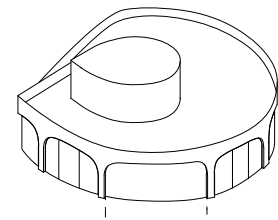

0:33

min:sec

Dimensions L x H = 8,115 x 2,950 mm, R = 8,000 mm Number 3 Weight per element 2 t

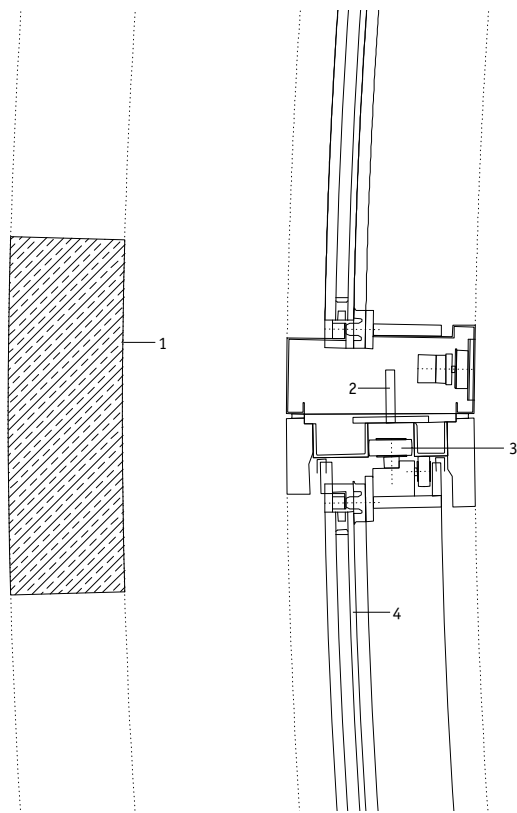

Detail plan of window element, 1:10

- 1 Precast concrete facade
- 2 Steel post with aluminium fascia
- 3 Lateral deflection rollers in guide rails
- 4 Lowerable glass panel

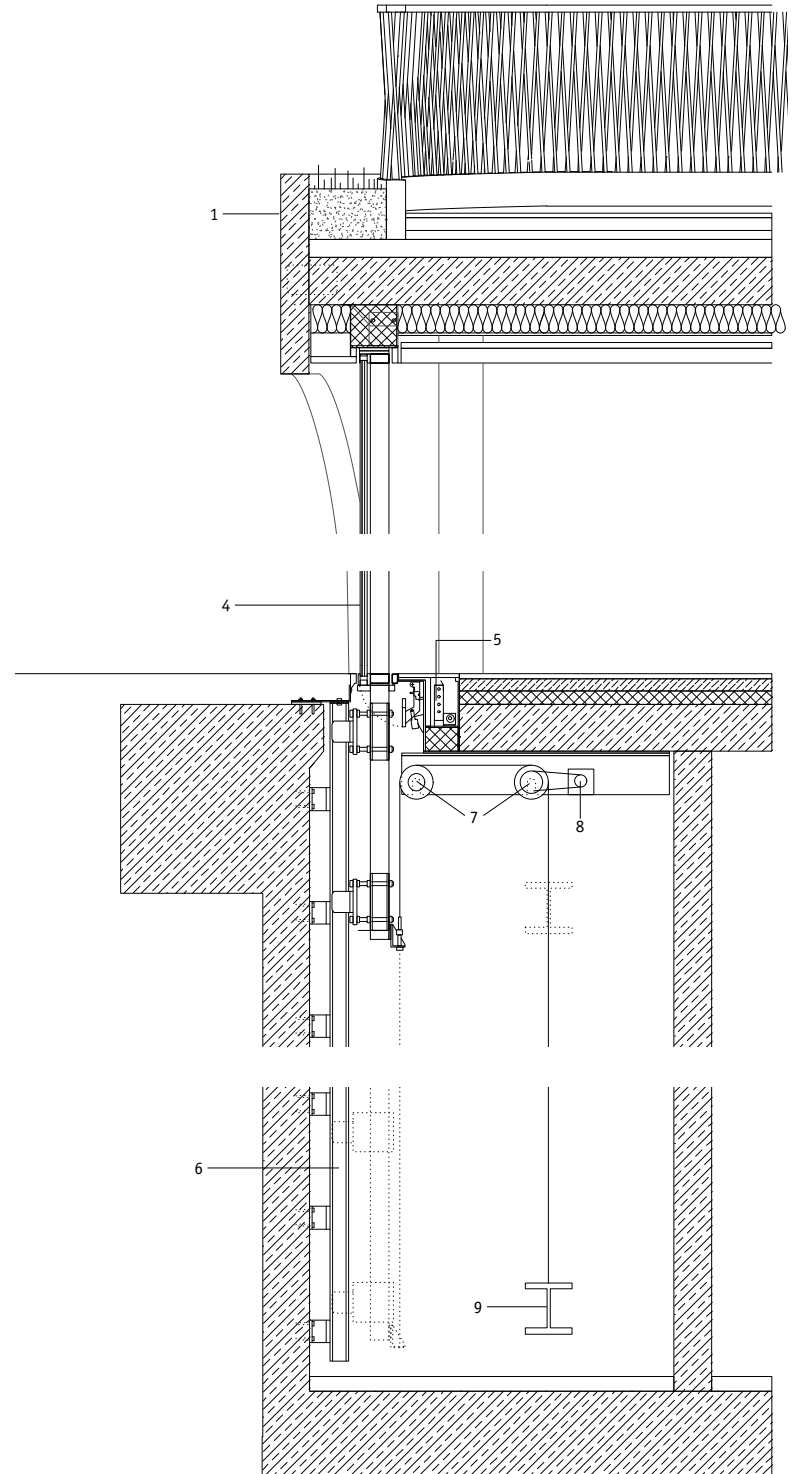

Section through facade, 1:40

Slide



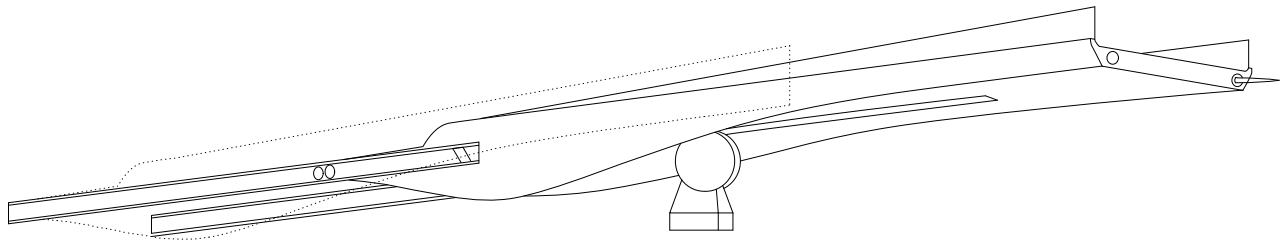

Axonometric projection of lateral guide rails of the bridge deck

## Inderhavnsbroen

Copenhagen, Denmark, 2016  
Studio Bednarski with COWI UK

The inner harbour bridge connects Copenhagen's Nyhavn with the up-and-coming district of Christianshavn. The 180 m long bridge for pedestrians and cyclists has been designed as a retractable bridge. It comprises two fixed, V-shaped sections on each quay from which two 7 m wide, tapered profile steel bridge decks extend to bridge the central span of 53 m. A bascule bridge at this point would have impaired the magnificent view across the harbour. When ships need to pass, the two halves of the central section retract into the fixed concrete sec-

tions on each side of the canal, which are accessible when the bridge is open and serve as excellent vantage points from which to observe the passing vessels.

The extension and retraction of the moving spans is achieved using a winch drive. With a W-shaped cross section that grows slenderer towards the centre, the moving sections roll over 1.80 m wide load wheels visible beneath the bridge. The moving spans are held in position laterally by guide rollers running in stainless steel guide rails. The motor and

drive mechanism on each quay are housed below ground, which has the benefit that the process of extension and retraction produces very little noise, causing minimum disturbance in the inner-city area. Since its opening, the shift in the position of the cycle lane between the wider fixed sections on either side and the narrower central span has proved problematic, as cyclists travelling at speed all too easily overlook the abrupt lane switch at the end of the respective bridge section.

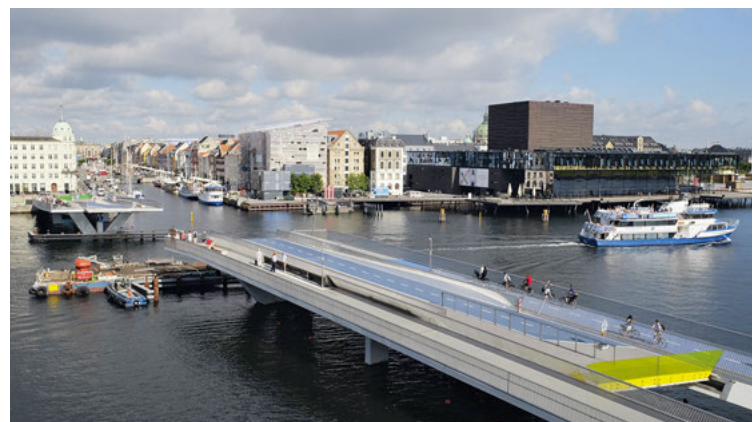

Bridge in open and closed states

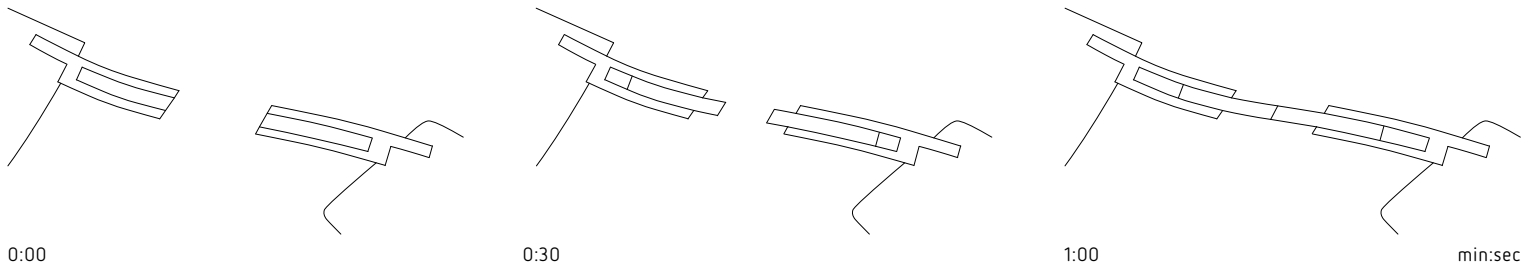

Dimensions L x W = 53 x 7 m Number 2 Weight per element 230 t

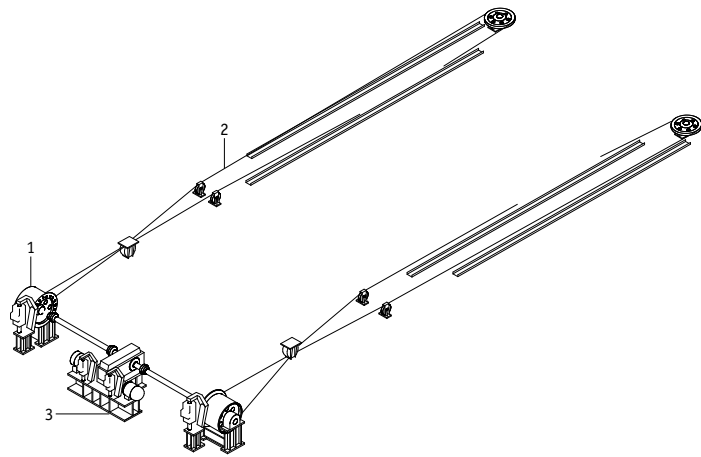

Axonometric projection of the winch drive mechanism



Underside of the drive system

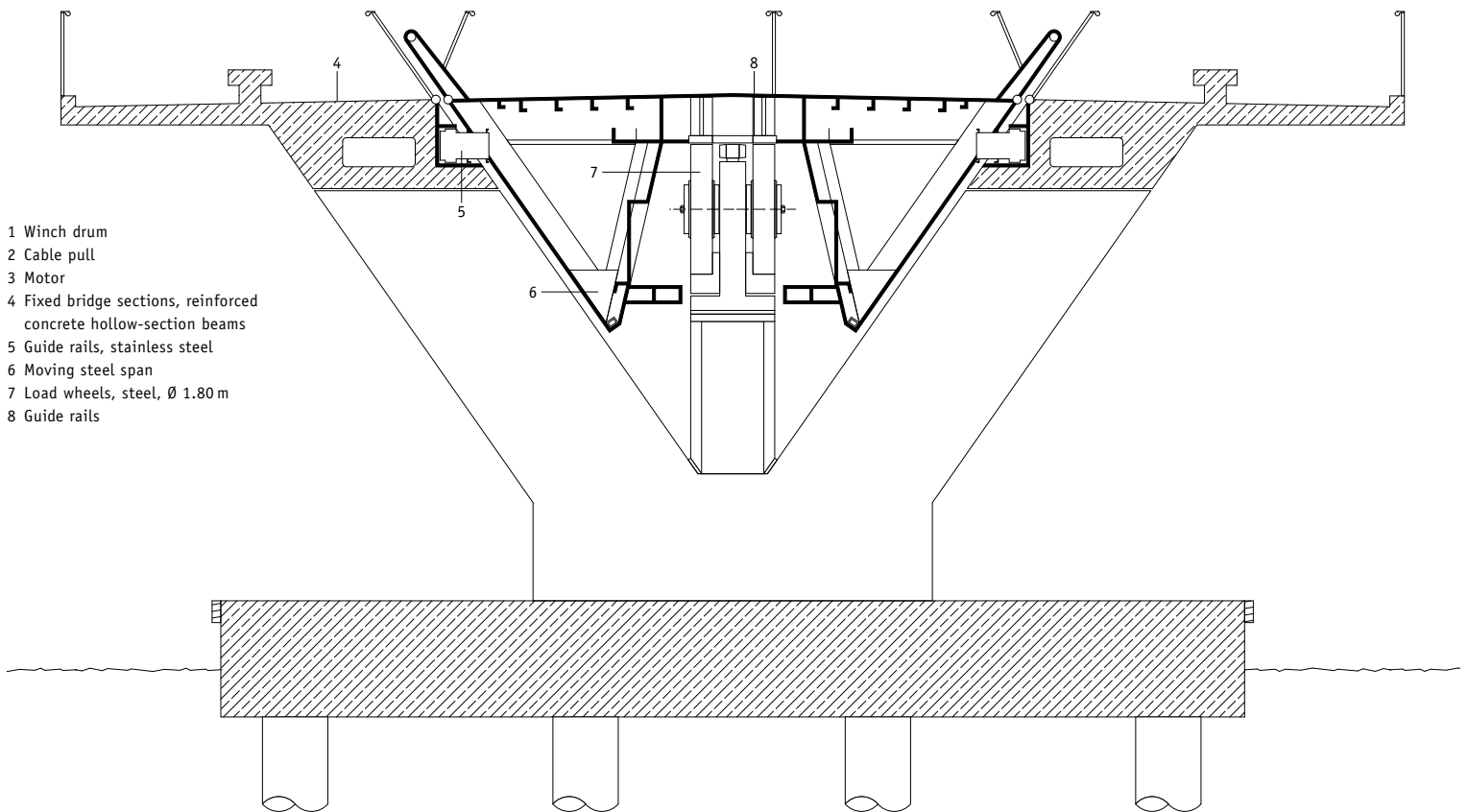

- 1 Winch drum
- 2 Cable pull
- 3 Motor
- 4 Fixed bridge sections, reinforced concrete hollow-section beams
- 5 Guide rails, stainless steel
- 6 Moving steel span
- 7 Load wheels, steel, Ø 1.80 m
- 8 Guide rails

Cross section through bridge, 1:100

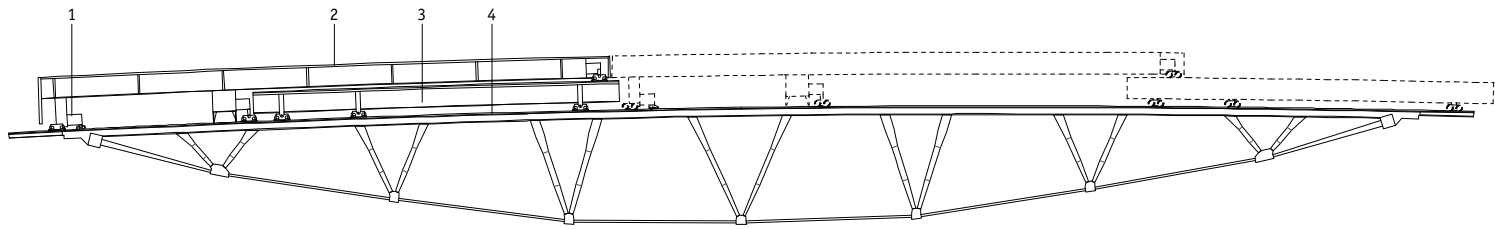

Longitudinal section of movable roof elements (not to scale)

## Wembley Stadium

London, UK, 2007  
Foster + Partners

Wembley Stadium in the London Borough of Brent is the home of the English national football team. Built from 2003 to 2007, it replaced an earlier stadium on the same site from 1924. With a capacity of 90,000 spectators, it is one of the largest sports stadiums in the world. The most striking and iconic element of the stadium, visible from afar, is the 133 m high arch that spans the stadium and supports part of the roof construction.

The roof covers the spectator stands and can be retracted in good weather on the south side to allow sunlight into the stadium and aid pitch growth. The 52 m high roof has a total area of approx. 40,000 m<sup>2</sup>, 13,700 m<sup>2</sup> of which are retractable.

The arch, one of the largest of its kind, supports both the northern, fixed part of the roof via a net of steel cables, and indirectly 60% of the load of the southern, sliding elements of the roof. Their load is transmitted transversely to the northern roof via stayed trusses. Of the seven sliding roof sections, three at each end are parked stacked above one another and extend to cover the end sections of the stadium. The seventh, translucent roof section covers the front grandstand and is supported by bow-string trusses.

The movable roof elements travel on articulated bogies along the six cable-stayed steel trusses, which at the south end rest on the stadium structure and

at the north end are suspended from the arch. This is necessary in order to accommodate movement in the supporting structure. The whole roof moves back and forward on a rack and pinion system which affords precise control and positioning. The roof is operated from the control room using an electronic control system with built-in redundancy.

Due to the large roof spans, significant deformations and bends in the construction can occur in the roof, which had to be calculated during the planning process in such a way that the initially unloaded elements could be brought into their final shape during the step-by-step suspension of the roof.

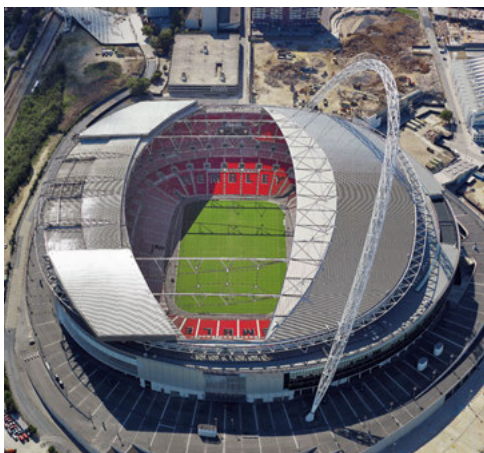

Aerial view of stadium



Interior view with closed roof

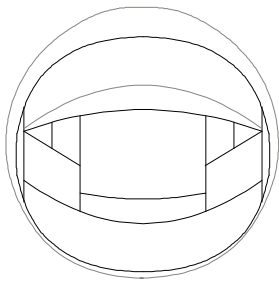

0:00

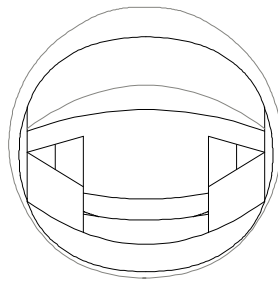

20:00

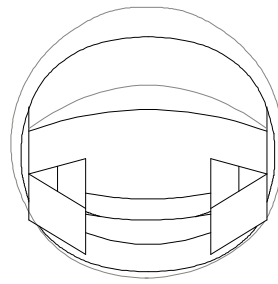

40:00

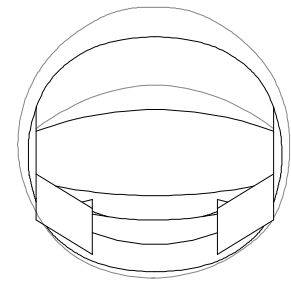

60:00

min:sec

.....  
**Dimensions** 13,700 m<sup>2</sup> movable roof area **Number** 7

- 1 Bogie on a pivot arm
- 2 Lateral support of the upper roof element
- 3 Beam of the lower roof element
- 4 Cable-stayed truss of the main roof
- 5 Drive unit of the lower roof element
- 6 Gear rack
- 7 Pinion gear

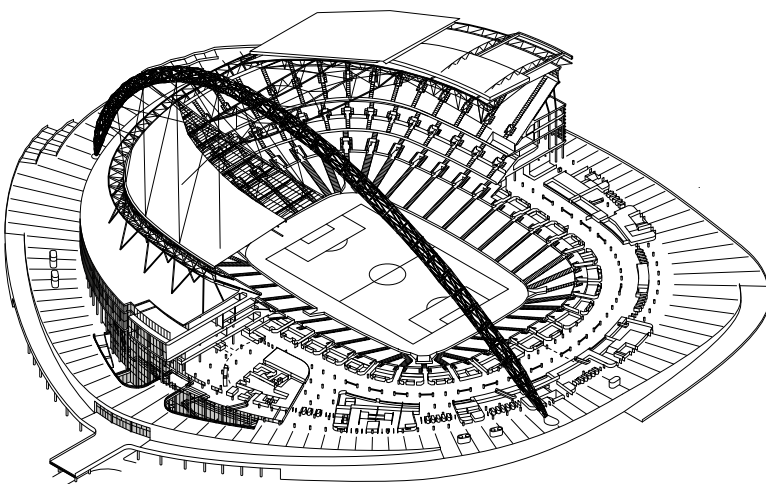
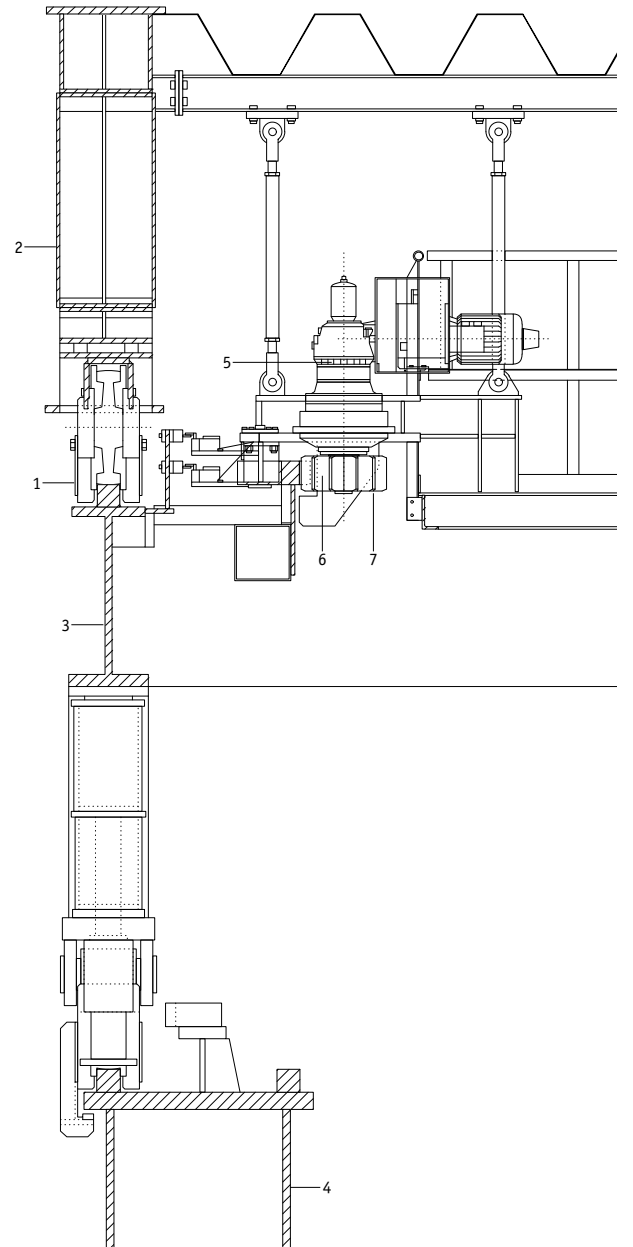

Axonometric projection of the stadium with longitudinal section

Cross section of the stacked roof elements with drive mechanism, 1:25

Slide





View from the road

## Aktivhaus B10

Stuttgart, Germany, 2014  
Werner Sobek

Aktivhaus B10 is part of a research project into how innovative and sustainable materials, constructions and technologies can improve our built environment. Thanks to a sophisticated energy concept and a forward-looking, self-learning building automation system, the “active house” generates twice as much energy from sustainable energy sources as it requires for its operation. It also incorporates a number of important design innovations. Aktivhaus B10 was planned in the space of a few months, factory prefabricated as a timber structure, and assembled on site within a day. Its structural innovations include a fold-down facade element that can also serve as a terrace.

The terrace in front of the building is attached to the steel supporting framework on which the house

also rests. Divided into four separate sections, the terrace can be hydraulically rotated from horizontal to vertical to close off the glazed building frontage, for example to reduce thermal heat loss through the building envelope at night, or when the residents are away. The underside of the terrace elements has the same white textile facade surface material as the other external walls so that it blends in seamlessly when raised. The textile allows the facades to be backlit at night. When open and in a horizontal position, the terrace almost doubles the usable area of the house.

The terrace lies on the west side of the building and, when open, provides access to the building. One of the folding sections serves as a driveway for an electric “Smart” car, which is part of the building

concept: the residents can drive directly into the apartment and load and unload indoors. The car parks on a rotating turntable that allows the owners to drive both into and out of the building in a forwards direction. An aspect of the research project is to investigate how this can assist elderly and/or disabled people in getting in and out of the car, and to see how parking electric vehicles at room temperature can extend their range by reducing the consumption of electricity for warming up or cooling down the vehicle interior when driving.

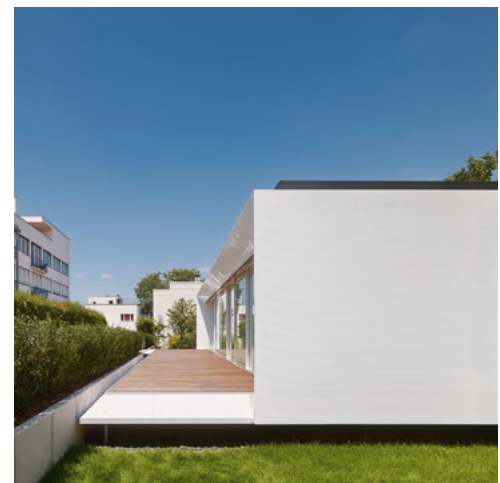
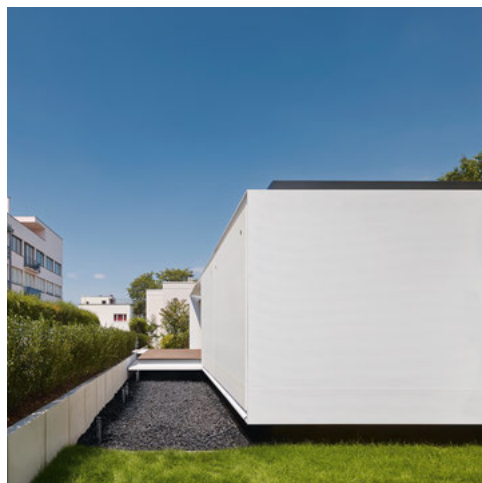
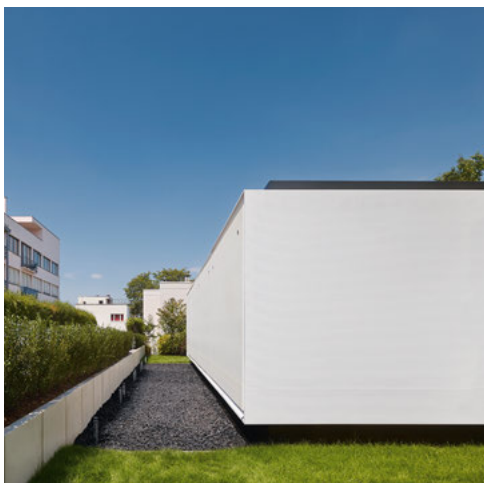

Opening sequence of the facade

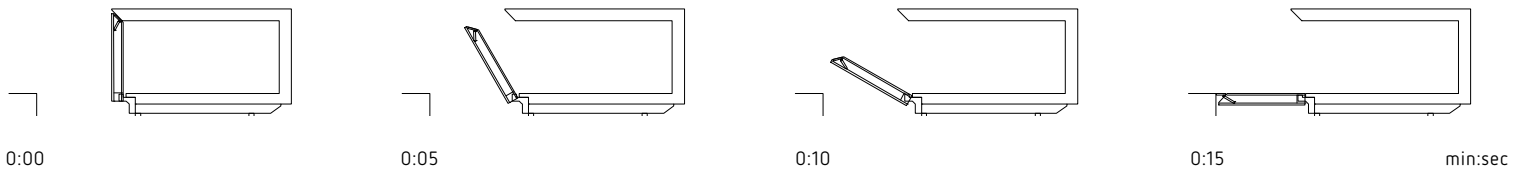

.....  
**Dimensions** W × D × H = 3.40 × 0.30 × 3 m    **Number** 4    **Weight per element** 500 kg

- 1 Hydraulic cylinder for raising the end strip
- 2 Terrace decking of thermally modified wood
- 3 Facade element, Teflon-coated fibreglass membrane
- 4 Hydraulic cylinder for raising the terrace elements
- 5 Portal frame

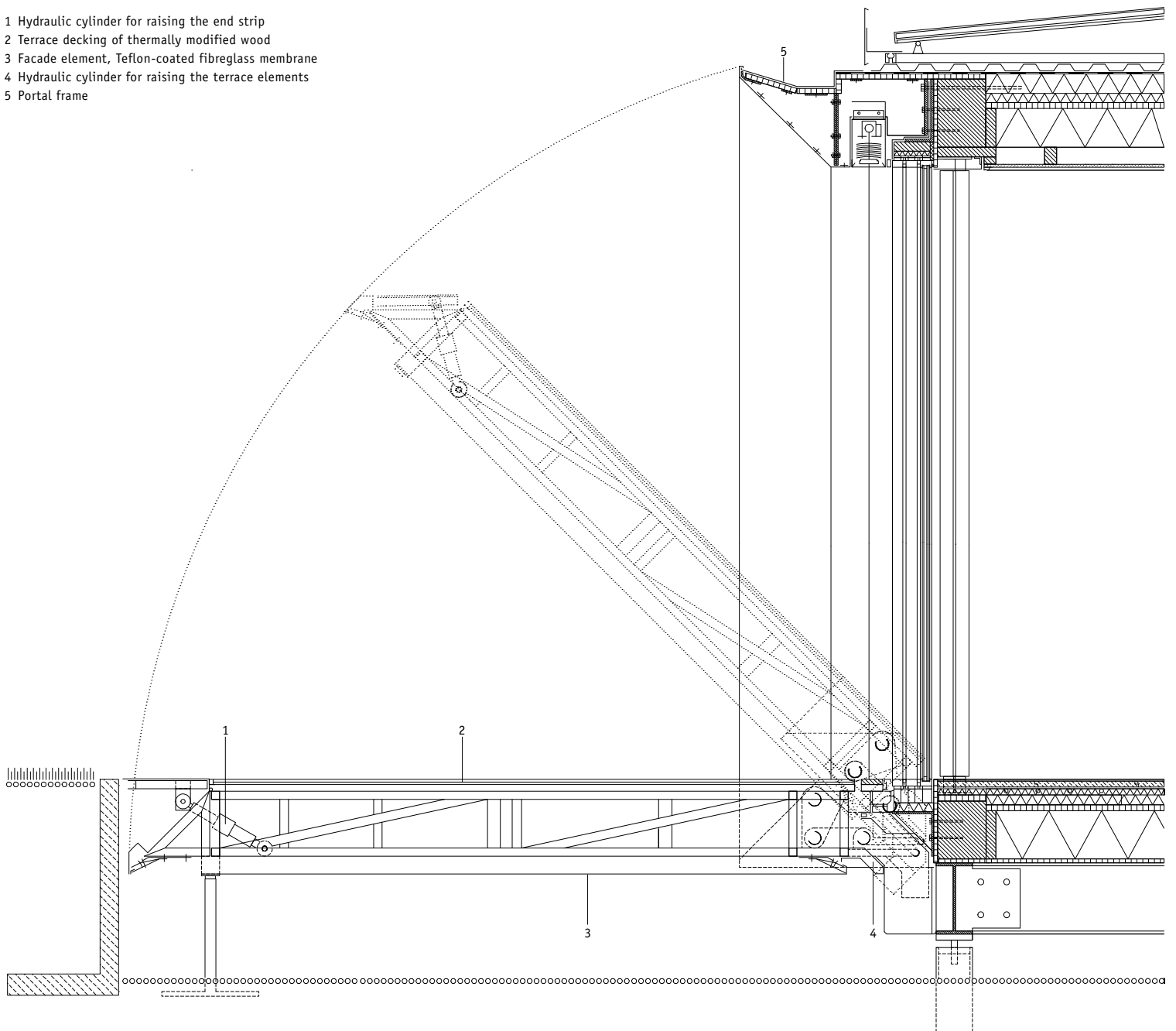

Cross section, 1:25

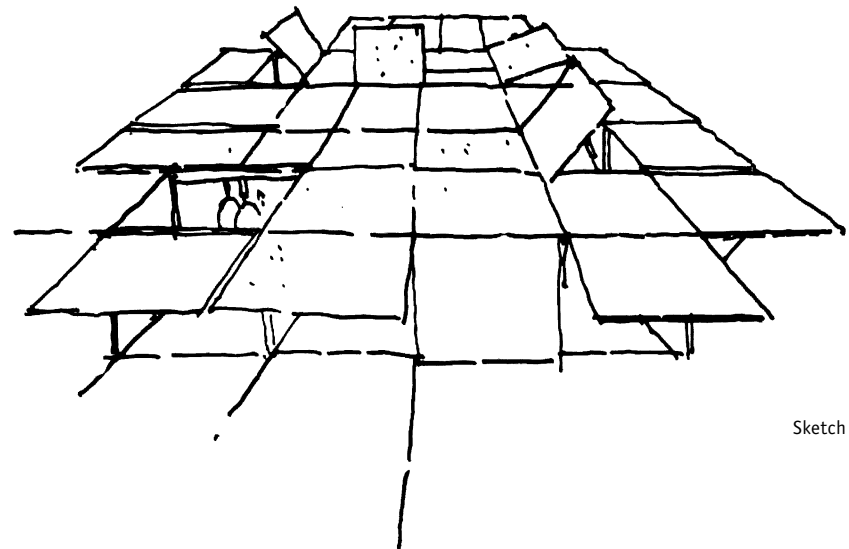

Sketch

## MPavilion 2014

Melbourne, Australia, 2014  
Sean Godsell Architects

This MPavilion was built in 2014 as a temporary pavilion for public cultural events and activities in the Queen Victoria Gardens in Melbourne. After four months it was then dismantled.

The pavilion needed to be sufficiently adaptable to accommodate different types of events, with controlled access, especially at night. From this came the idea of an openable building skin with modular

metal panels in the facade and roof that can be opened and closed using electric actuators.

Different configurations were devised to meet various requirements. Hinged at the roof edge, the facade panels could be raised by up to 90° to protrude horizontally. The ability to open sections of the roof surface as well made it possible to control the degree of light and shadow. The changing pattern of facade

and roof panels recall the diurnal cycle of a flower that blossoms during the day and closes at night.

Constructed as a prefabricated steel construction with perforated metal panels, the pavilion was transported in modules of 2.40 × 2.40 m and assembled on site into a 12 × 12 m pavilion within just 72 hours.



Pavilion with facade panels closed



Pavilion with panels fully open

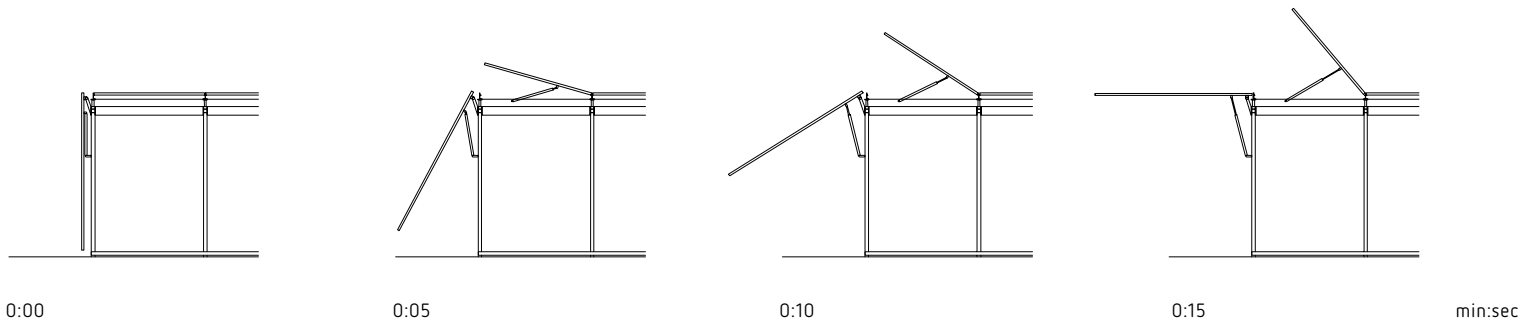

.....  
**Dimensions**  $W \times H = 2.40 \times 3 \text{ m}$  and  $L \times W = 2.40 \times 2.40 \text{ m}$     **Number** 20 and 25    **Weight per element** 48 kg and 40 kg

- 1 Perforated aluminium panel on galvanised steel frame
- 2 Hollow square-section steel profiles 70 x 70 mm
- 3 Steel angle as part of ceiling grid supporting the screens
- 4 Electric actuator, remote-controlled
- 5 Individually produced steel beams
- 6 Plexiglass roof covering
- 7 Stopper
- 8 Timber floor on modular steel profile underfloor
- 9 Ramp, precast reinforced concrete slab

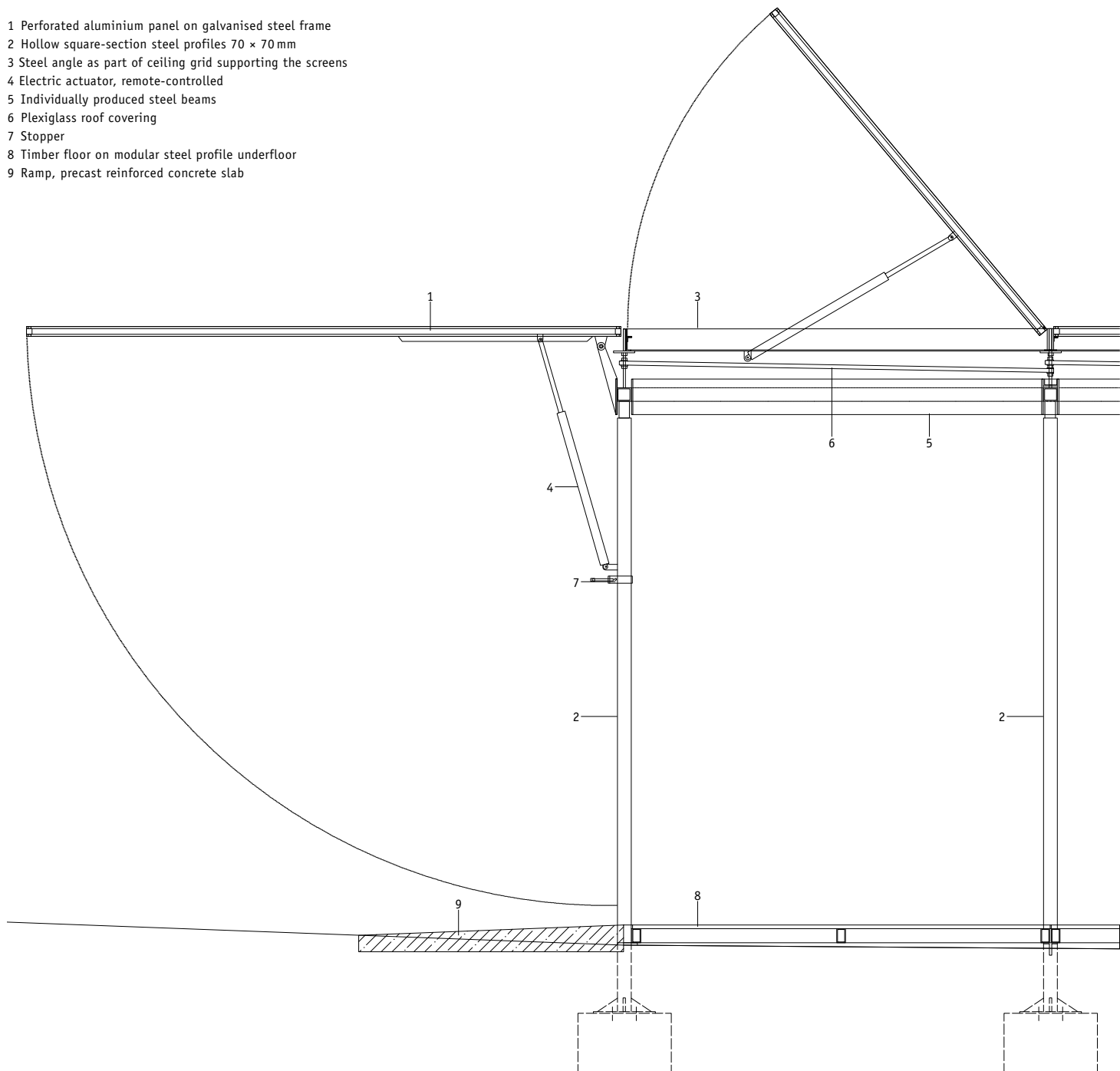

Section, 1:35

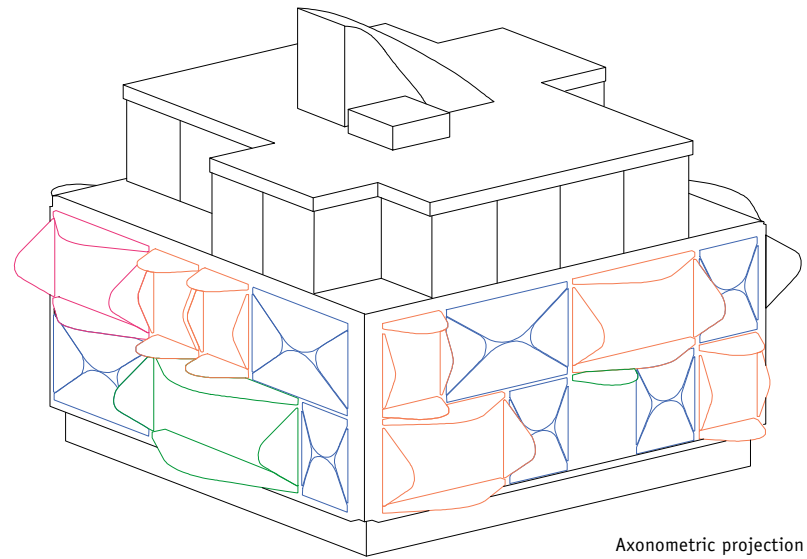

Axonometric projection

## Ballet Mécanique

Zurich, Switzerland, 2017  
Manuel Herz

The multi-family house is located in a residential district in the heart of Zurich, near the lake and only a few metres from the Pavillon Le Corbusier, built in 1967 for the Heidi Weber Museum. The pavilion, with its colourful metal panels and striking geometry, became the point of reference for the residential building project Ballet Mécanique. Its elevation on supports and the combination of industrial-looking modules and artistic, handcrafted building elements draw inspiration from the work of Le Corbusier.

The building is a simple rectangular volume with a centrally arranged circulation core providing access

to five apartments with various typologies, each suitable for a different family structure and lifestyle. The facade, on the other hand, is juxtaposed with the building's simple form and consists of horizontally and vertically arranged metal shutters that are triangular with rounded tips. The horizontal panels fold out into usable balconies with a corresponding canopy while the vertical panels function as shutters, shading the interior when closed and providing privacy when open.

The metal panels fold out of or back into the facade by means of hydraulic cylinders. There are four different types of element: the first is movable and,

together with a corresponding fold-out railing, becomes a walk-on balcony; the second is likewise movable but has no railing and serves as a sun breaker or shutter; the third type are rigid elements that are permanently usable as balconies, and the fourth, the closed wall sections, are identical to the other panels but fixed in place.

While the building's exterior has a uniform metallic champagne colour, the inner faces of the movable panels have been given strong blue and red hues. When the panels are completely closed, the building appears monochrome, but when open it presents a rainbow of blue and red tones.



Opening sequence of the facade elements



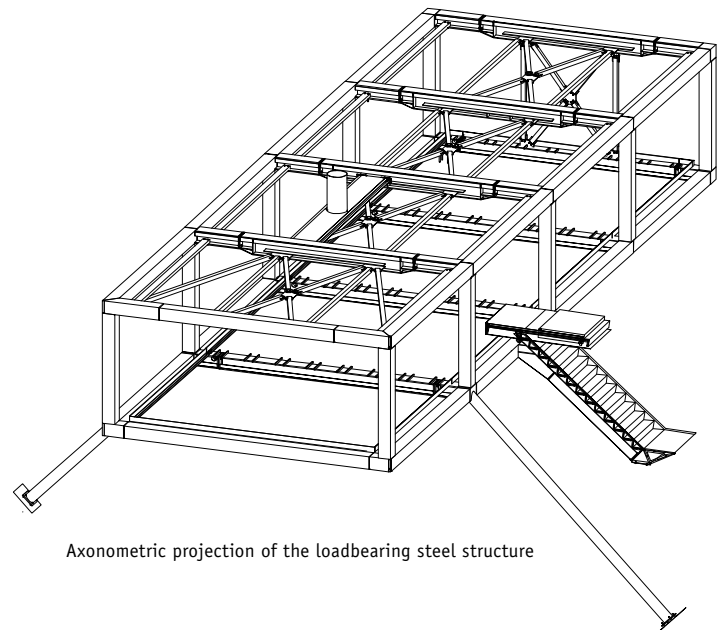

Axonometric projection of the loadbearing steel structure

## Villa Chardonne

Chardonne, Switzerland, 2009  
MADE IN Architecture

The single-storey detached house appears to float above the steep, uneven Swiss landscape of the Lavaux wine-growing region, with a clear view over the UNESCO World Heritage Site of Vevey on Lake Geneva. The steel structure of two parallel Vierendeel trusses and perimeter glazing rests on a cellar and plant room embedded in the slope and two inclined steel supports that extend as far as the property boundary. The building's structure is therefore largely raised off the ground allowing the landscape to flow freely beneath it.

In keeping with this concept, access from the garden is via a sculptural, unfolding cantilevered structure that is both a rotating flight of stairs and a hinged glass parapet. The staircase can be raised, giving the house a somewhat enigmatic silhouette and preventing access from below to the living floor. The stair construction is raised and lowered using a hydraulic cylinder and rotates about a horizontal axis of rotation that lies in the plane of the steel structure of the building. At the top end of the flight of stairs is a 1.80 m long steel section that

extends at an angle to act as a counterweight to the stairs and as a static support when lowered. At the base of the stair, a small platform folds out to rest on a concrete foundation from where one can step out onto the terrain of the hillside.



Elevation with raised and lowered entrance stair



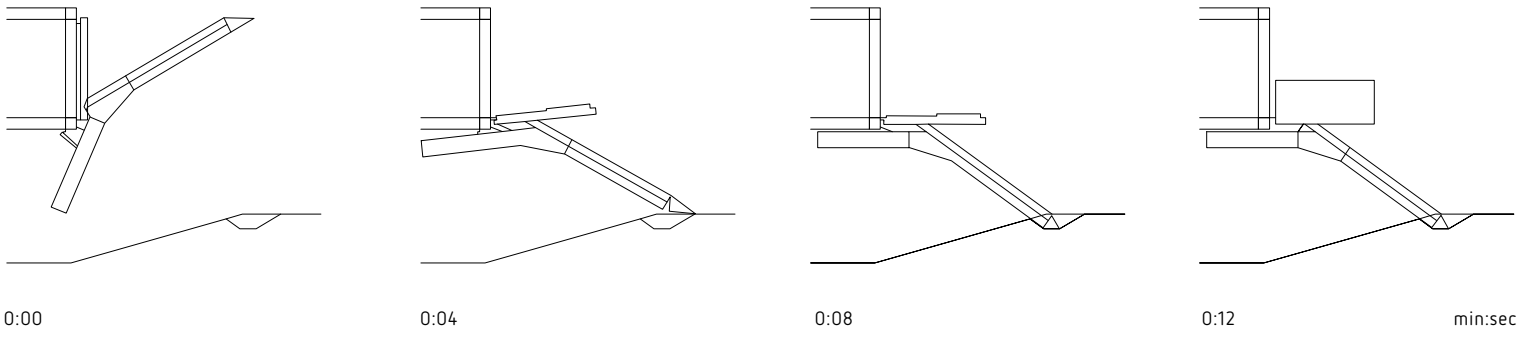

Dimensions W x L x H = 1.20 x 6 x 2.40 m    Number 1

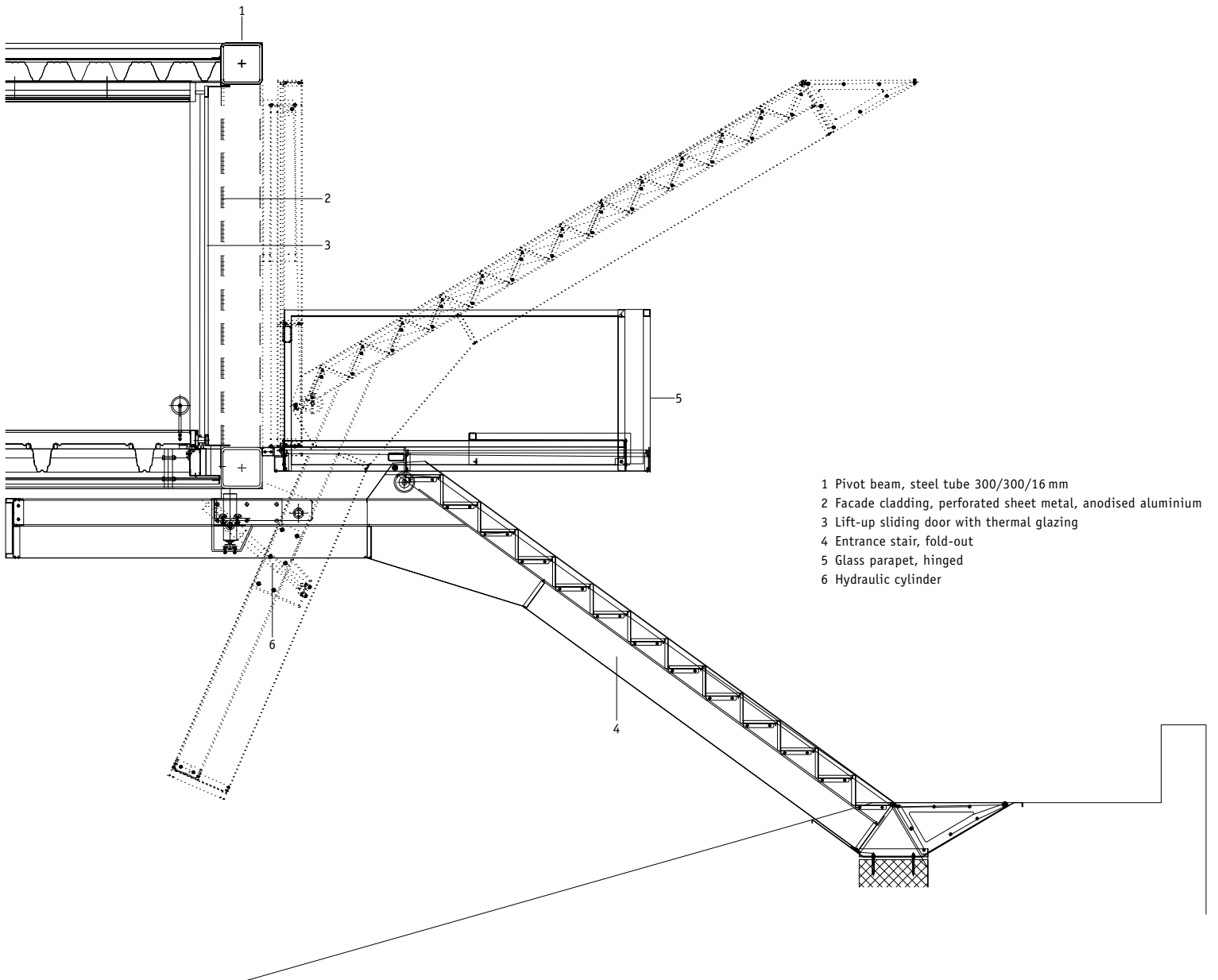

Section, 1:50



## Gdańsk Shakespeare Theatre

Gdańsk, Poland, 2014

Renato Rizzi with Proteco Engineering S.r.l.

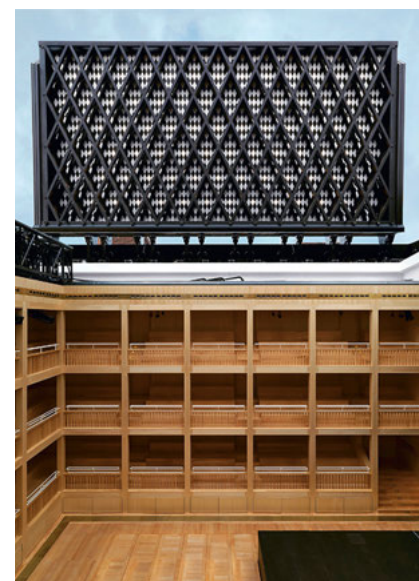

Stage and theatre boxes beneath the open roof

The Shakespeare Theatre in Gdańsk takes the historic Shakespearean Globe Theatre in London as its model. The building's large size, dark ribbed facade and openable roof makes it stand out in the silhouette of the city. The total volume is divided into several building sections, of which the 18 m high fly tower and the 12 m high Elizabethan theatre are the most striking. When the roof is open, one can look from the fly tower into the interior of the theatre. The ribbed structure of the facade is not just a design feature, but also serves to dissipate wind forces acting on the building when the roof is open. A visitor platform at a height of 6 m runs around the

building, providing a good view of the historical and new parts of the city while doubling as an escape route and connection to all levels of the building complex.

The mechanically openable roof consists of two halves that rotate 90° from horizontal to vertical via hinges at the top of the external walls of the theatre. When open, the building silhouette staggers in height from 0–6–12–18–24 m and transforms the interior into an open-air playhouse.

In contrast to the weighty, compact solidity of the external walls, the theatre interior is fitted out in light-coloured wood. The 2.8 × 2.8 × 2.8 m module

of the theatre boxes is based on finds made during archaeological excavations at the site. The 51 modules can accommodate some 600 spectators and are arranged in a C-shaped figure with six modules along each of the long sides and five at the short end, distributed across three storeys.

Like the roof, both stages in the theatre auditorium are fully mechanised and movable, with the moving mechanism located beneath the floor in the basement layer of the theatre.



Opening sequence of the roof

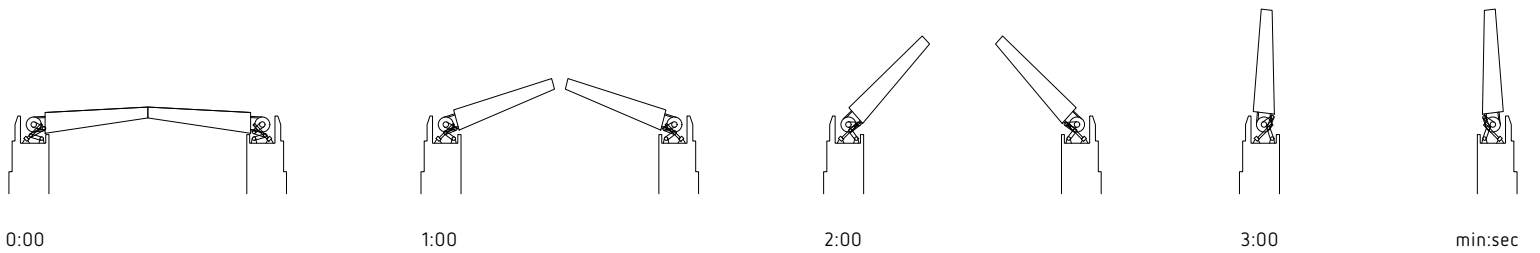

Dimensions W × L = 11.60 × 20.56 m    Number 2    Weight per element 46 t

- 1 Roof covering, copper
- 2 Roof construction, space frame
- 3 Pivot
- 4 Lifting gear, worm drive
- 5 Motor

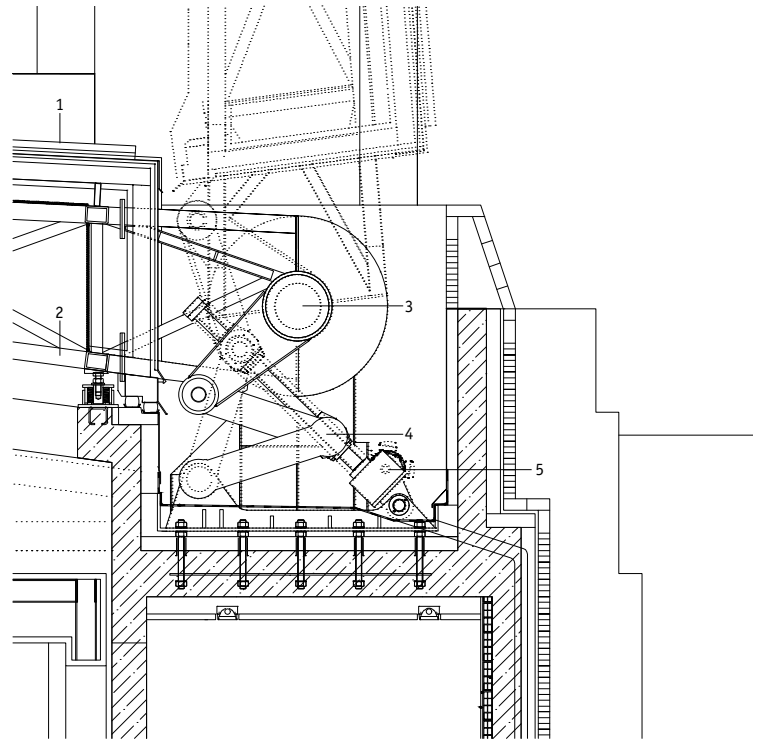

Detail, 1:150

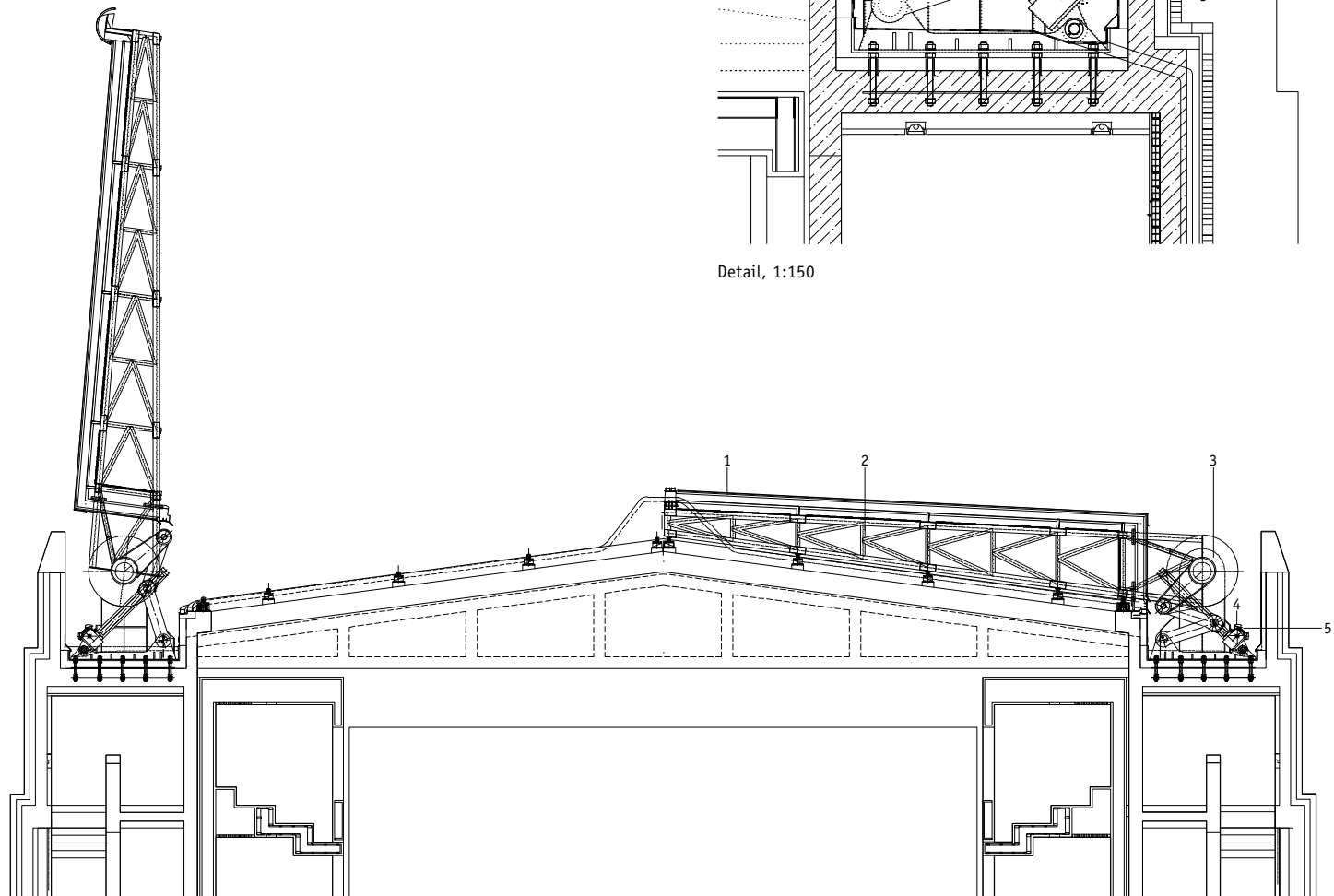

Section, 1:350

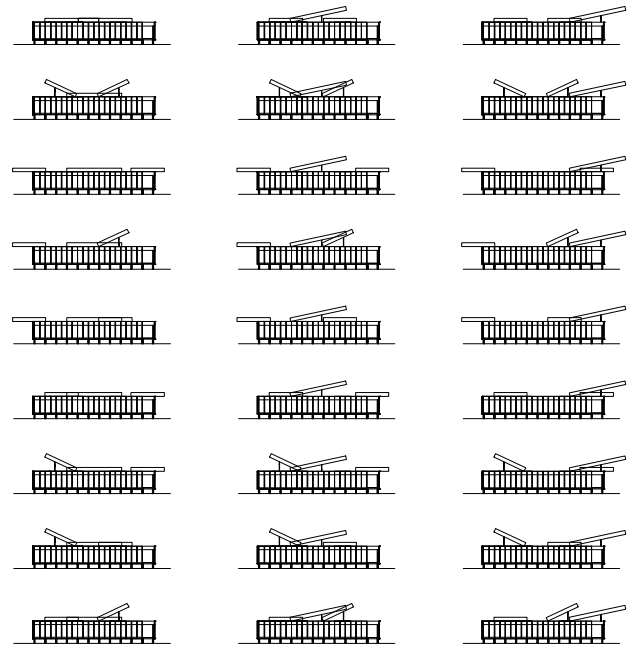

Opening scheme of the main roof

## Olympic Tennis Centre

Madrid, Spain, 2009

Dominique Perrault Architecture

The tennis centre houses tennis courts and admin offices and was built in the run-up to Spain's bid to host the Olympic Games. One of the most striking aspects of the sports building is the roof, which gives the building its shape and its nickname "The Magic Box". With three sliding, removable roof elements, the different tennis courts can be flapped open independently of each other, enabling indoor and outdoor competitions to be held simultaneously. In extreme weather situations, games and events can be interrupted for a few minutes to allow the roofs to be closed.

The movable main roof has a size of  $103 \times 73$  m and consists of a conventional truss structure, enhanced

with a three-dimensional structure. The roof can be tilted by  $12^\circ$  about a single axis along its 103 m long side, and then shifted back perpendicular to that axis by up to 65 m. This entire process takes 15 minutes at a speed of 5 m per minute. The geometry of this solution is based on triangles of decreasing edge-length that align with the bogies. Two triangular leg constructions rest on the bogies with a hydraulic cylinder between them that reduces the movement path to the shortest length possible and permits their alignment in the guide rails.

The other two roof covers are each  $44 \times 60$  m and consist of a truss-like supporting construction.

Both these covers can be opened by  $25^\circ$ , tilting about their long axes. The tilting system likewise uses hydraulic cylinders that rest directly on the mobile structures and are mounted on special twin chassis arrangements with rail supports. Each chassis has two 420 t hydraulic cylinders, which bear the entire load of the roof element over a distance of 6.50 m and transfer it to the fixed structural framework of the building. Two safety bolts lock the roof covers so that they no longer rest on the lifting jacks, once open. The eight twin trolley arrangements each have four 80 mm wheels.



Main roof open



Hydraulic mechanism

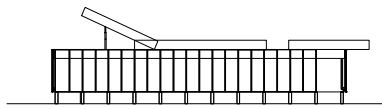

0:00

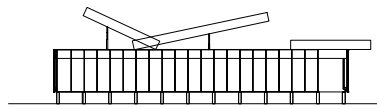

10:00

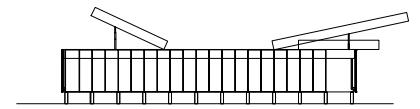

20:00

min:sec

Dimensions L x W x H = 103 x 73 x 5 m and 60 x 44 x 5 m Number 3 Weight per element 1,200 t, 2 x 420 t

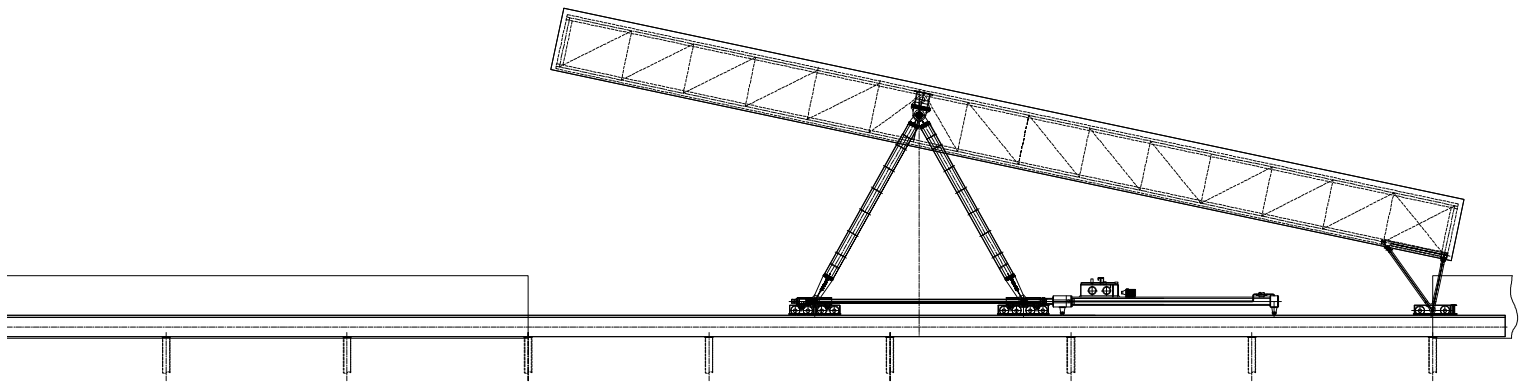

Elevation, 1:600

- 1 Roof covering, aluminium sheeting elements with clip connection
- 2 Aluminium trapezoidal sheet, 44 mm
- 3 Aluminium trapezoidal sheet, 44 mm, insulation, 40 mm acoustic fleece
- 4 Opening mechanism, hydraulic
- 5 Steel beam, 900/1,200 mm
- 6 Trolley
- 7 Guide rails

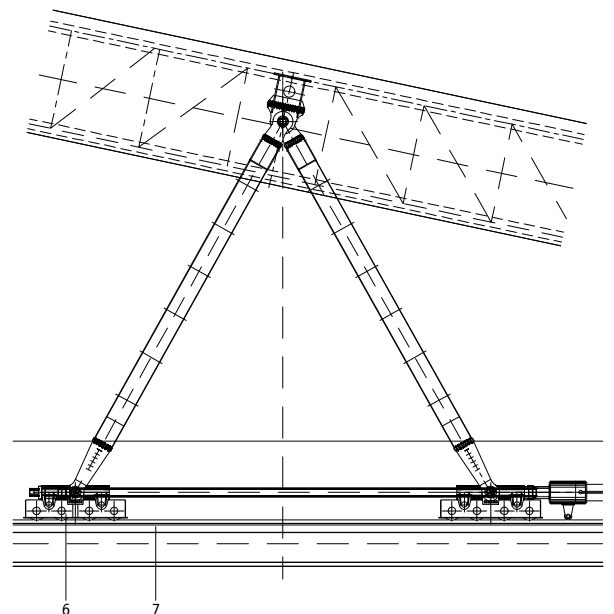
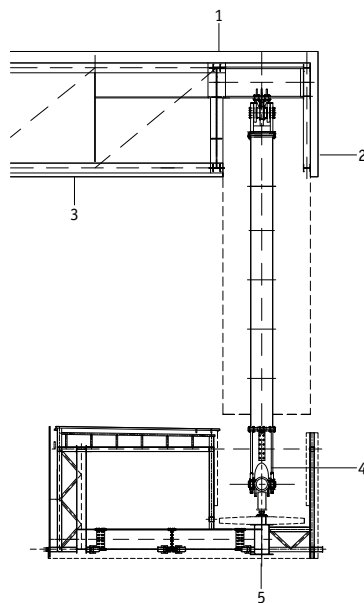
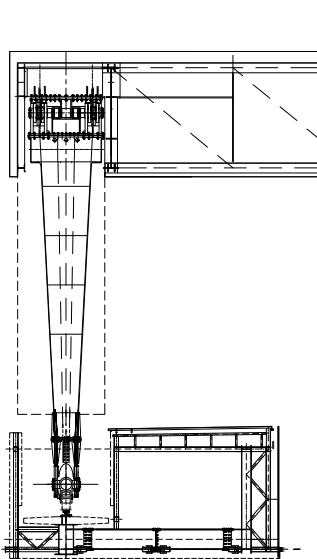

Sections, 1:300

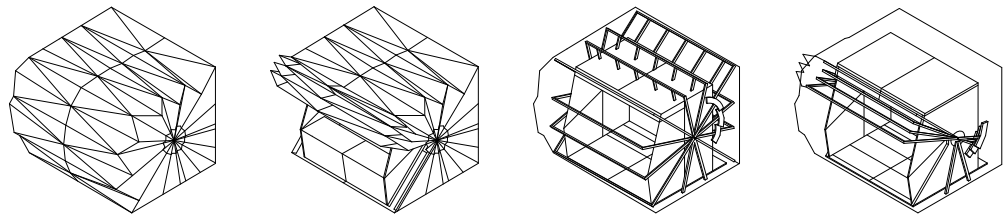

Pictograms of the folding skin and closing mechanism (folding inner frame)



## Canary Wharf Kiosk

London, UK, 2013  
Make Architects

For the Canary Wharf Ice Sculpting Festival in 2014 in London's Docklands, Make Architects designed two foldable kiosks that served as the festival's sales and information office.

Their sculptural form resembles a complex folded origami sculpture. Each of the 1.95 × 3 m kiosks is clad in a folded shell of aluminium panels that arches over the kiosk opening at the front. Beneath this shell is a rectangular skeleton frame made of hollow square-section profiles that contains a single

room equipped with a counter extending the entire length of the opening. Three steel frames anchored at a central hinge hold the arched folded cover on the front and can be raised to cause the shell to fold together in accordion fashion. The frames are each held in position by a counterweight that can be moved by an electric winch at the press of a button. The outer shell is made of triangular powder-coated aluminium panels, which require little maintenance due to their robust and easy-to-clean surfaces and

are resistant to vandalism. The movable panels are linked by hinges along the entire length of the folds. The folded hinges are fashioned from the edge of each panel and interlocked with a steel pin threaded through them. The inside of the kiosk is clad with plywood panels and sealed with a waterproof membrane.

The entire kiosks were factory prefabricated and installed on the festival site in one piece without the need for foundations.



Closed state



Open state

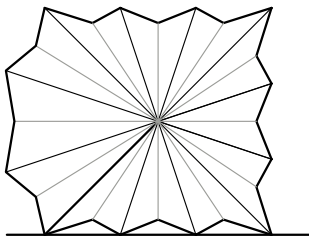

0:00

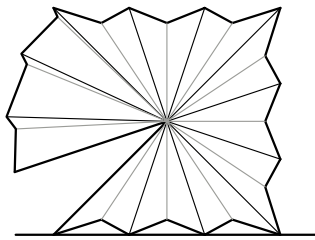

0:15

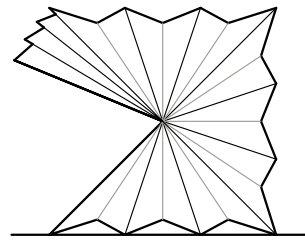

0:30

min:sec

Dimensions 3 m flat facade Number 1 Weight per element 150 kg Drive Motorised

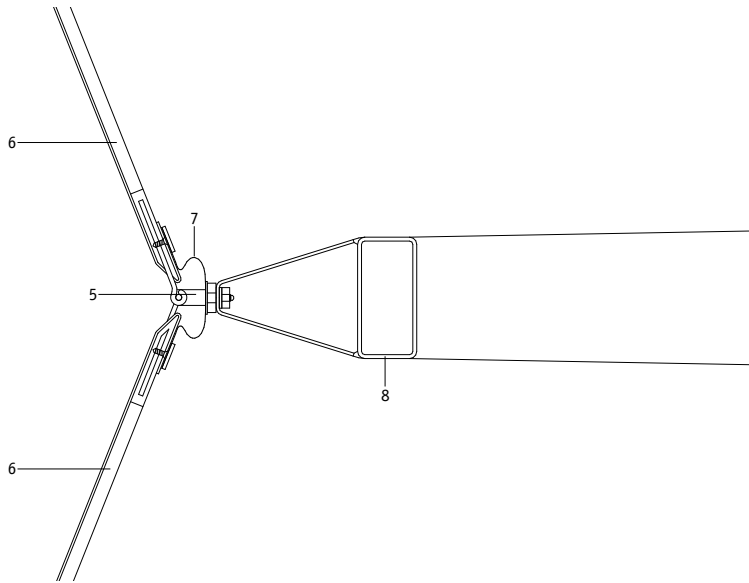

Cross section folding construction, 1:5

- 1 Electric winch
- 2 Pulley
- 3 Counterweight, 10 mm stainless steel, red
- 4 Axis of rotation
- 5 Folding hinge
- 6 Aluminium panel
- 7 Sealing strip
- 8 Hollow steel profile, 80 × 40 mm RHS

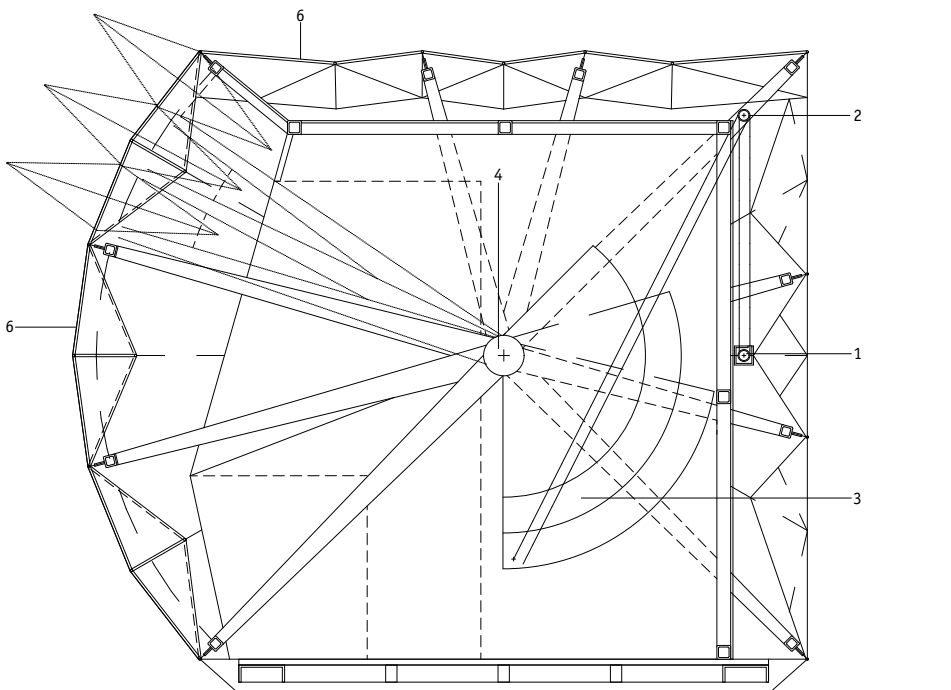

Section, M 1:33



Outer skin

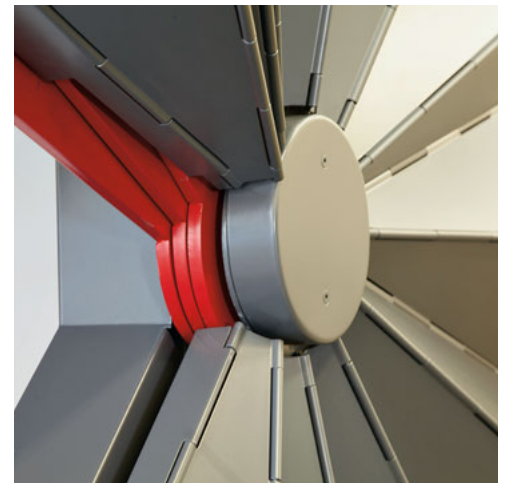

Central hinge

Fold





## Café-Restaurant OPEN

Amsterdam, Netherlands, 2008  
Pi de Bruijn and de Architecten Cie.

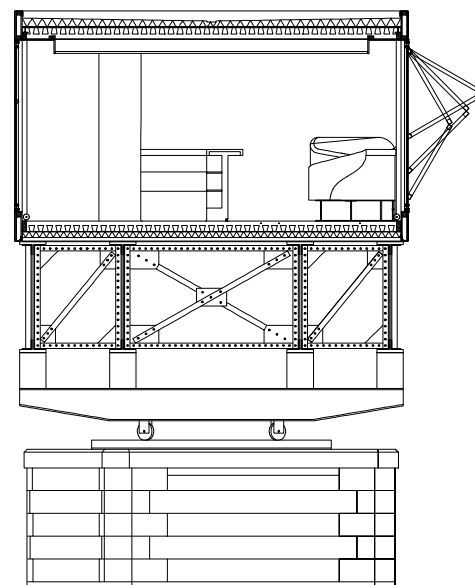

Cross section (not to scale)

Café-Restaurant OPEN is situated on one of the last remaining swing bridges in Amsterdam. Built in 1922 as a railway bridge between Westelijk Stations-eiland and Westerdokseiland, the city decided to convert it into a pedestrian bridge due to its good condition and beautiful views. In 2005 an open competition was announced for a café and restaurant, which was won by the office of de Architecten Cie.

The café-restaurant seems at first to be little more than a floor, a ceiling and intermediary glass fa-

acades. Two freestanding green cubes within the 840 m<sup>3</sup> space contain the kitchen, cloakroom, toilets and bar and free up the arrangement of the rest of the room. Benches are arranged along the glass facade along with a bar with seating. A small pedestrian bridge leads to the main entrance.

The glazed facades are articulated as folding windows and lend the building a subtle sense of refinement. Their particular sequence of movement also makes reference to its historical use as a revolving bridge: the windows open in an elegant wave-like

movement. Each wing is independently anchored in two guide rails and can be moved by means of a motor. When raised, they fold outwards in the middle, and when lowered a motor at the base pulls them into a vertical position. The wave-like pattern on the facade is a product of limiting the window opening angles along the length of the café.

This movable construction gives the simple modern glass volume a dynamic appearance and, at the same time, offers excellent views and adds to the quality of the visit.



Opening pattern of the folding glazing



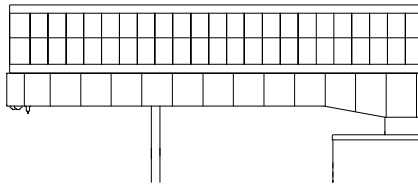

0:00

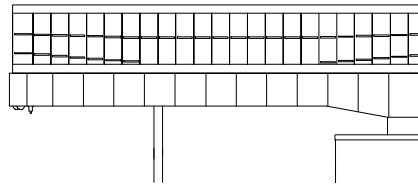

0:08

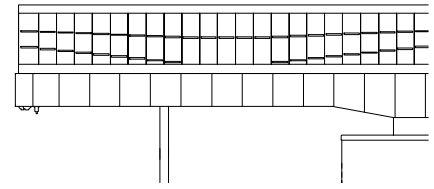

0:16

min:sec

.....  
**Dimensions** L × H = 1 × 2.86 m **Number** 30 folding windows

- 1 Tube motor
- 2 Hinge
- 3 Rotating bar lock
- 4 Facade element
- 5 Guide rail
- 6 Roller bearing

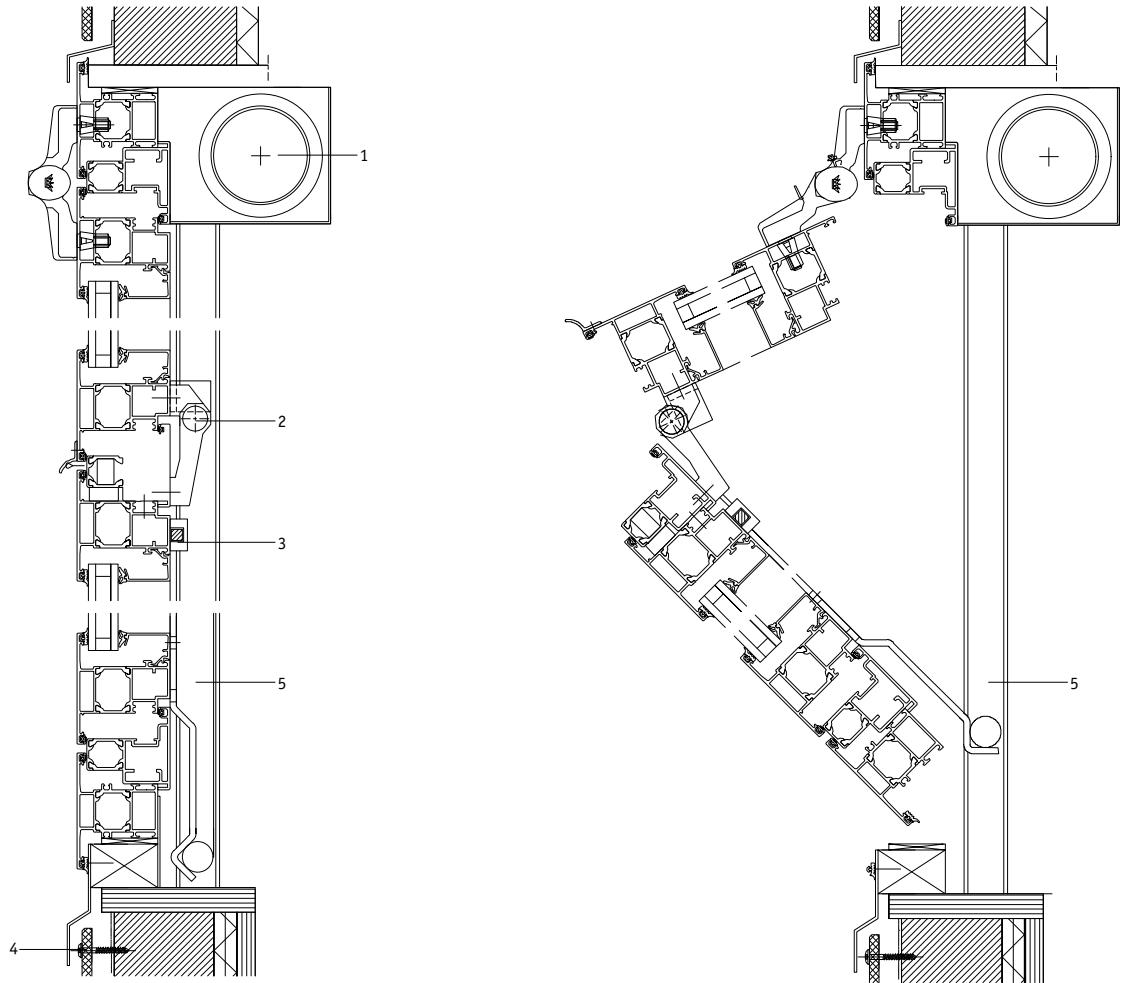

Vertical section, 1:5

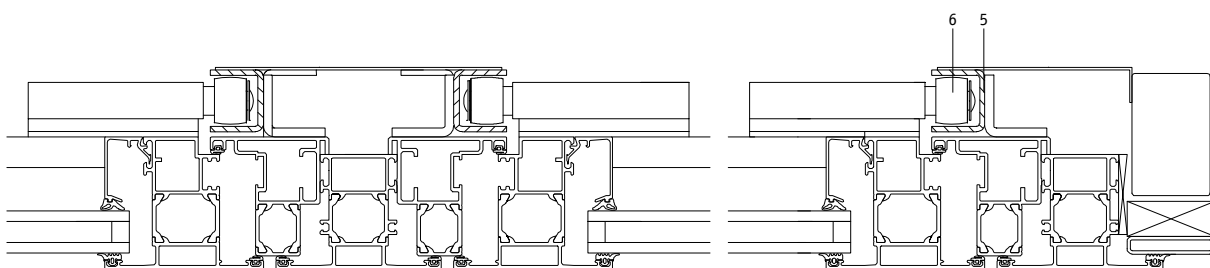

Horizontal section, 1:4



The museum exterior

## Mokyeonri Wood Culture Museum

Mokyeonri, Incheon, South Korea, 2017  
Eunju Han + softarchitecturelab

The Mokyeonri Wood Culture Museum in Incheon's Grand Park, South Korea, was built as a forestry and wood information centre. Soft Architecture's design, which won the competition organised by the city, envelopes the building with a movable facade of leaf-like timber elements that links the topic of the exhibition with the natural surroundings and timeless architecture.

The shape of the building is strikingly angular, presenting a sharp corner over the glazed entrance area

to visitors arriving from the adjacent car park. In front of the glass facade between the concrete floor and ceiling slabs, movable wooden elements have been assembled into a screen, through which light falls as if through a canopy of leaves, creating a play of mottled shadows. The movable wooden panels take the form of hexagonal "leaves" made of merbau hardwood and are joined in pairs to form foldable wings attached to vertical black metal profiles that in turn are fixed at the top and bottom

in runners. The wooden leaves are connected to each other by springs so that by shifting the metal profiles laterally, they open and close like wings. The metal profiles are shifted using a toothed belt driven by a motor, making it possible to adjust the distances between the vertical elements and the folding of the blades individually.



Walkway behind the facade screen

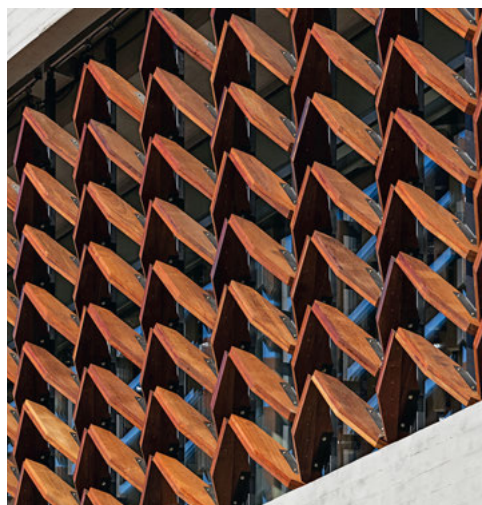

Moving facade

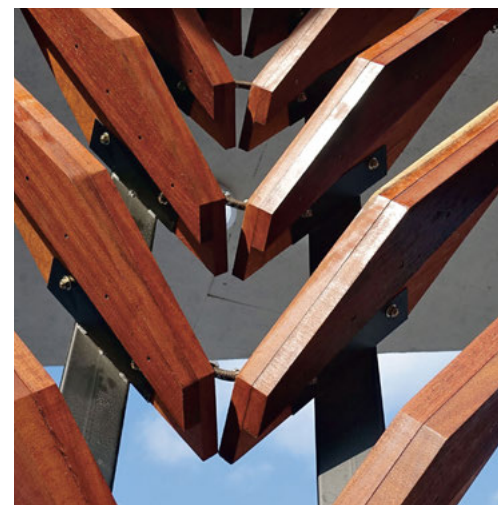

Element anchor and elastic connection

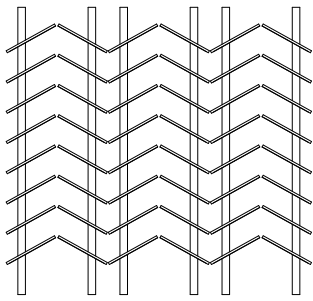

0:00

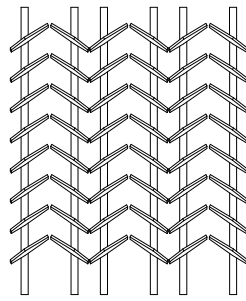

0:11

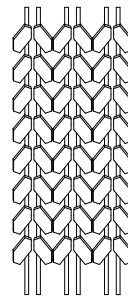

0:22

min:sec

.....  
**Dimensions** L × H = 4 × 4.50 m **Number** 26 **Drive** Motorised

- 1 DC motor
- 2 Drive belt
- 3 Tensioning roller
- 4 Guide rail
- 5 Runner
- 6 Joint
- 7 Wooden leaves, merbau

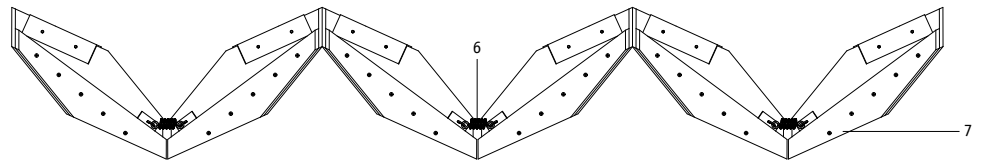

Wooden elements, 1:25

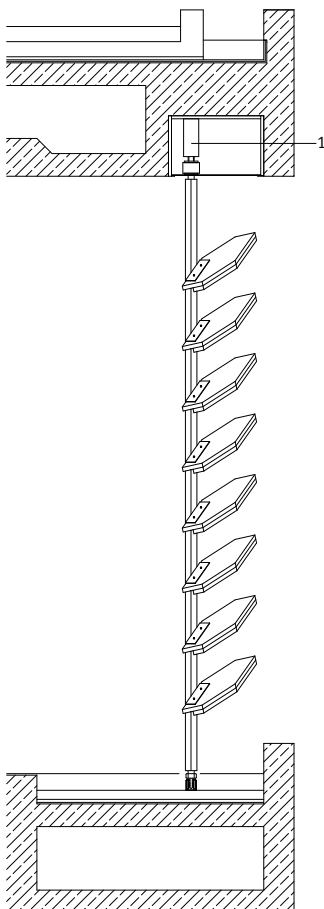

Section, 1:50

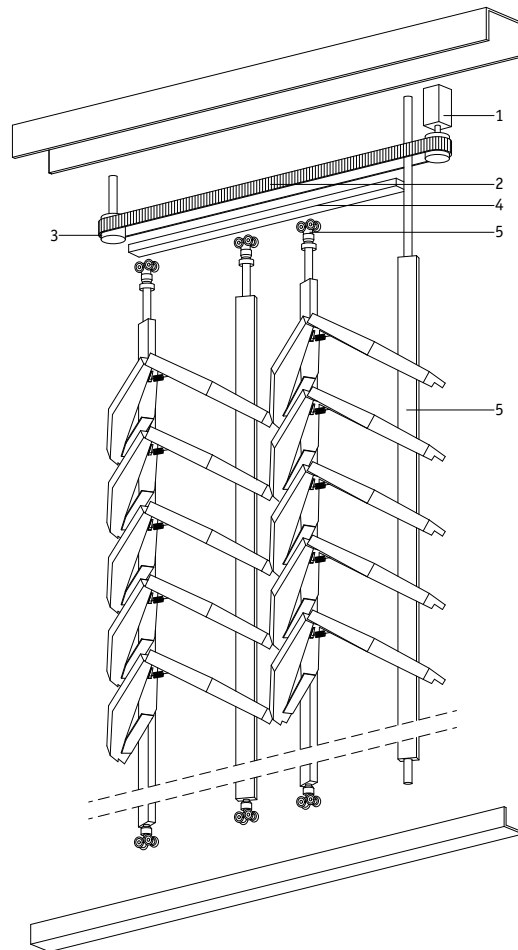

Perspective showing sequence of movement (not to scale)

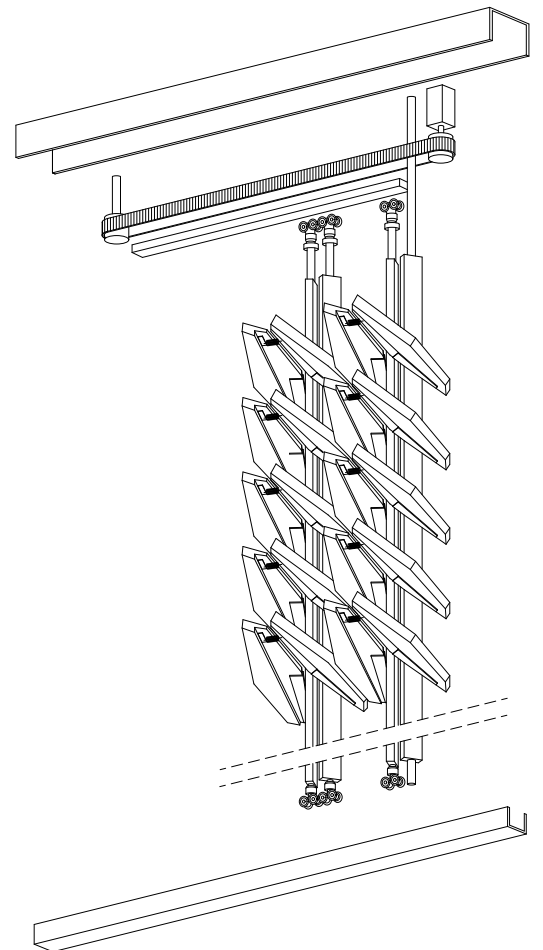

Fold





## Parliament Visitor Centre

Vienna, Austria, 2017

GEISWINKLER & GEISWINKLER Architekten ZT GMBH

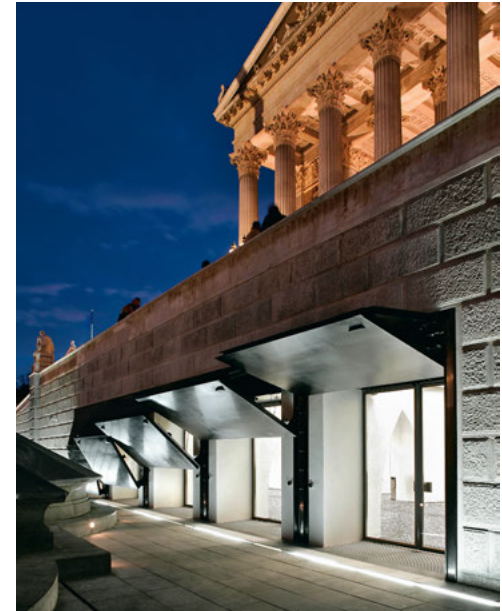

The existing building and its extension with folding shutters

The concept for the redesign of the main entrance area of the Austrian Parliament inserts a new, contemporary spatial experience into the historical architecture, reflecting the leading function of a modern Austrian Parliament. The newly created areas are merged to form an extensive spatial continuum, and the experience of the entrance hall has been heightened by a variety of carefully orchestrated new insertions. From the forecourt area and the statue of Athena, a new entrance area has been

created by reviving the idea of winter entrances as originally planned by the architect of the historical building, Theophil Hansen, and equipping them with folding shutters.

The new entrance features five horizontally folding shutters that are raised and lowered electronically and can be operated individually. The 3.00 x 3.20 m large shutters are divided into two sections and clad with 10 mm thick welded bronze panels.

As security and safety aspects were a particular concern, special measures were taken to ensure that the components of the folding shutters are robust, secure and safe in use.

When the folding shutters are closed, the metal panels and stone facing maintain the solidity and homogeneity of the entrance ramp to the upper level, preserving the overall impression and integrity of the historical building.

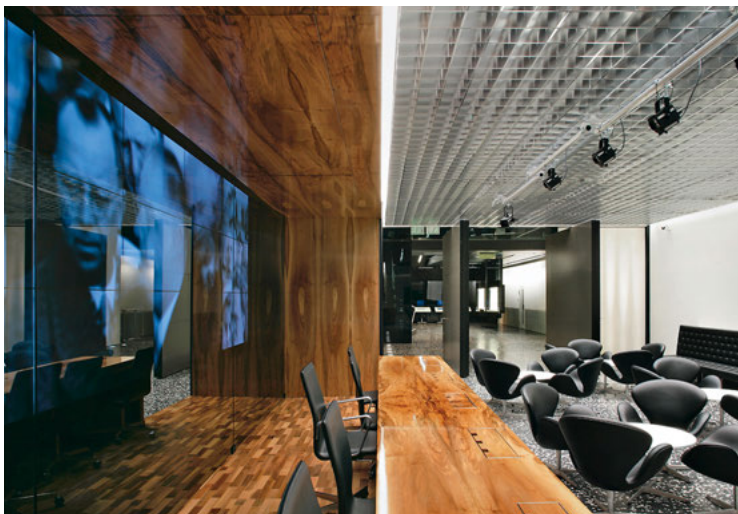

Interior views of entrance area

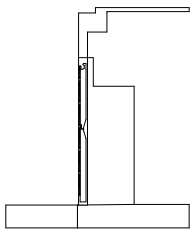

0:00

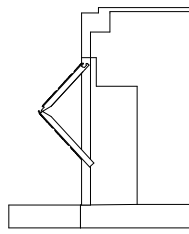

0:30

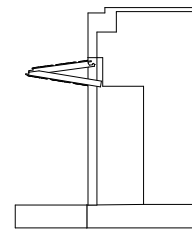

1:00

min:sec

Dimensions H x W = 3.10 x 3 m Number 5

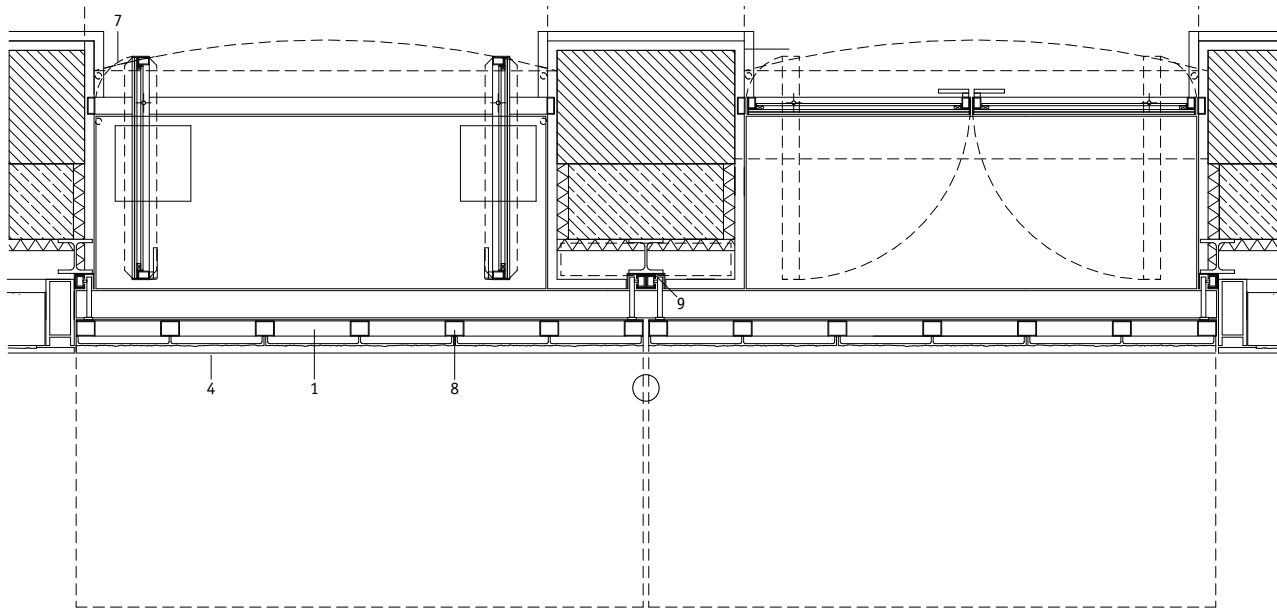

Floor plan (detail), 1:50

- 1 Folding shutters
- 2 Motor drive with locking bolts
- 3 Sensor strip
- 4 Cast bronze panels, 100 x 70 cm
- 5 Door sensor
- 6 Emergency door opener switch
- 7 Outswing area with anti-trap protection
- 8 Steel frame, 10 x 8 cm
- 9 Guide channels

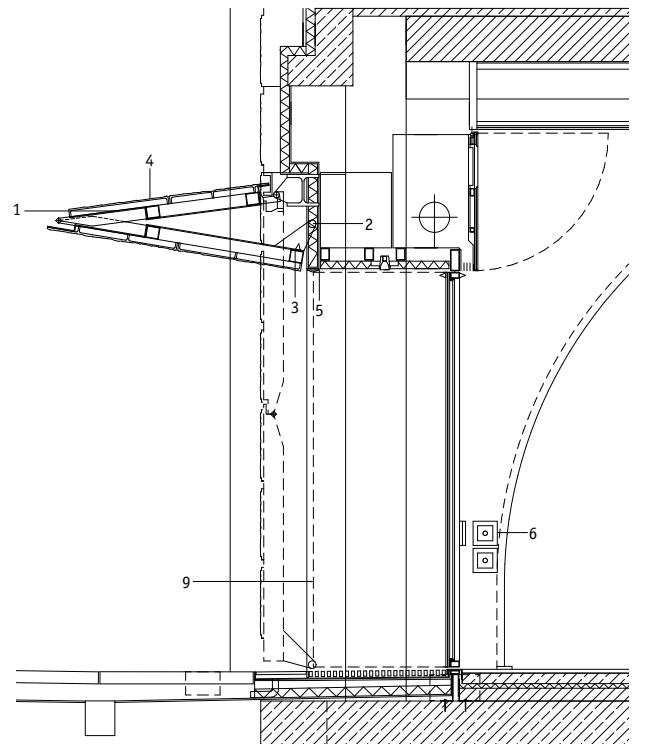

Vertical section, 1:50

Fold



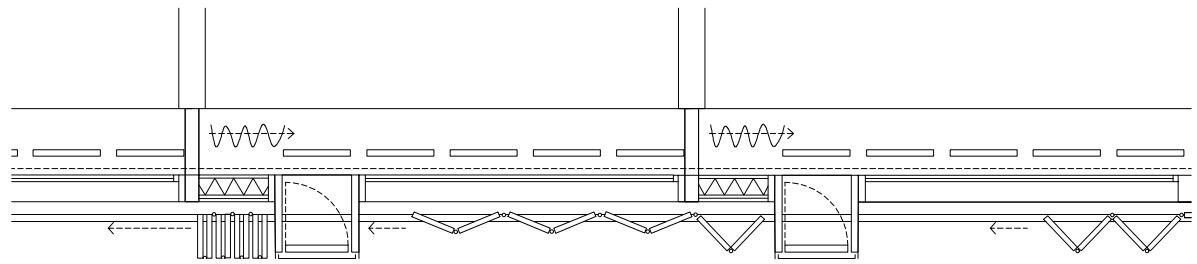

Horizontal section through facade (not to scale)

## Centre for Paediatrics and Cardiology at the University of Innsbruck

Innsbruck, Austria, 2008  
Nickl & Partner Architekten

The Centre for Paediatrics and Cardiology at the University of Innsbruck lies in the heart of the city, close to the winding alleys of the old town. The concept of the new building is informed by and shapes its urban surroundings. As the new backbone of the disparate clinic site, the building picks up the structure of the intact urban fabric and marks the transition between the historic city centre and the adjacent new district. Urban elements such as a boulevard, courtyard and house recur in the internal organisation of the building and help structure it and provide orientation.

The large-format windows of the facade provide an attractive view of the Alpine landscape but also re-

quire a means of screening views from the street. Therefore, for the wards on the upper floor, a system of broad panoramic windows was devised, with low sills serving as inviting wooden benches inside the rooms, and whose fixed glazing can be covered by a rigid sunshade and privacy screen of perforated metal folding sliding shutters on the outside.

Deep, box-shaped floor-to-ceiling vents, covered by perforated aluminium sheeting as a safety barrier, allow the patient rooms to be ventilated individually. Additional curtains on the inside in warm yellow-orange shades lend the rooms a homely atmosphere. Seen from in front, the champagne-coloured anodised perforated sheets of the folding sliding

shutters and ventilation boxes produce a regular, unobtrusive facade. Only as one moves around the building do the coloured sides of the ventilation boxes become apparent, giving the building its memorable appearance.

Some 200 folding sliding shutters were installed. They travel on runners attached to every second shutter element that runs along slim guide rails at a height of up to 4 m. The staggered pattern of round holes in the shutters provides a diffuse view of the mountain panorama even when closed.



Folding sliding shutters, partially open and closed



Folding sliding shutters when open



0:00

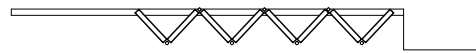

0:08

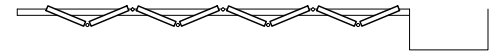

0:16

min:sec

Dimensions L x W x H = 5.50 x 0.75 x 4 m Number 200

- 1 Top guide rail
- 2 Runner with outrigger arm
- 3 Shutters, perforated metal
- 4 Edge profile with hinge
- 5 Drive unit housing
- 6 Bottom guide rail

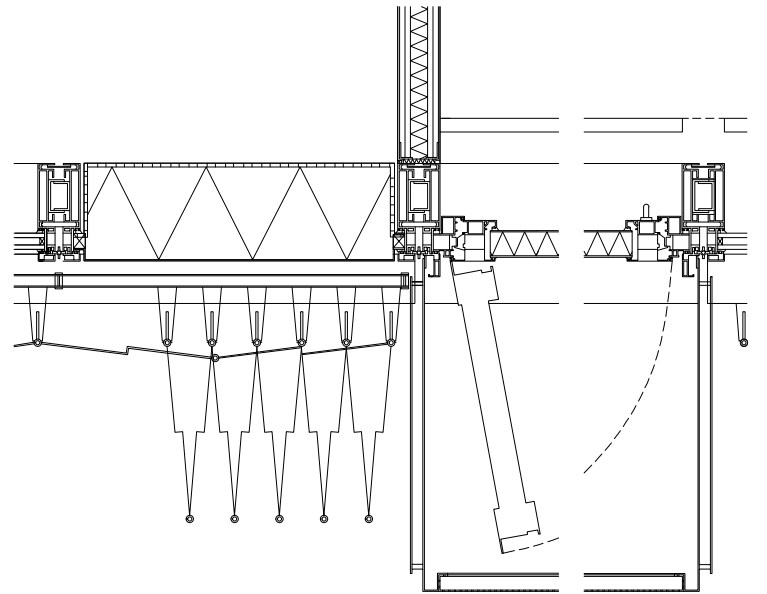

Horizontal section, folding sliding shutter in open position, 1:25

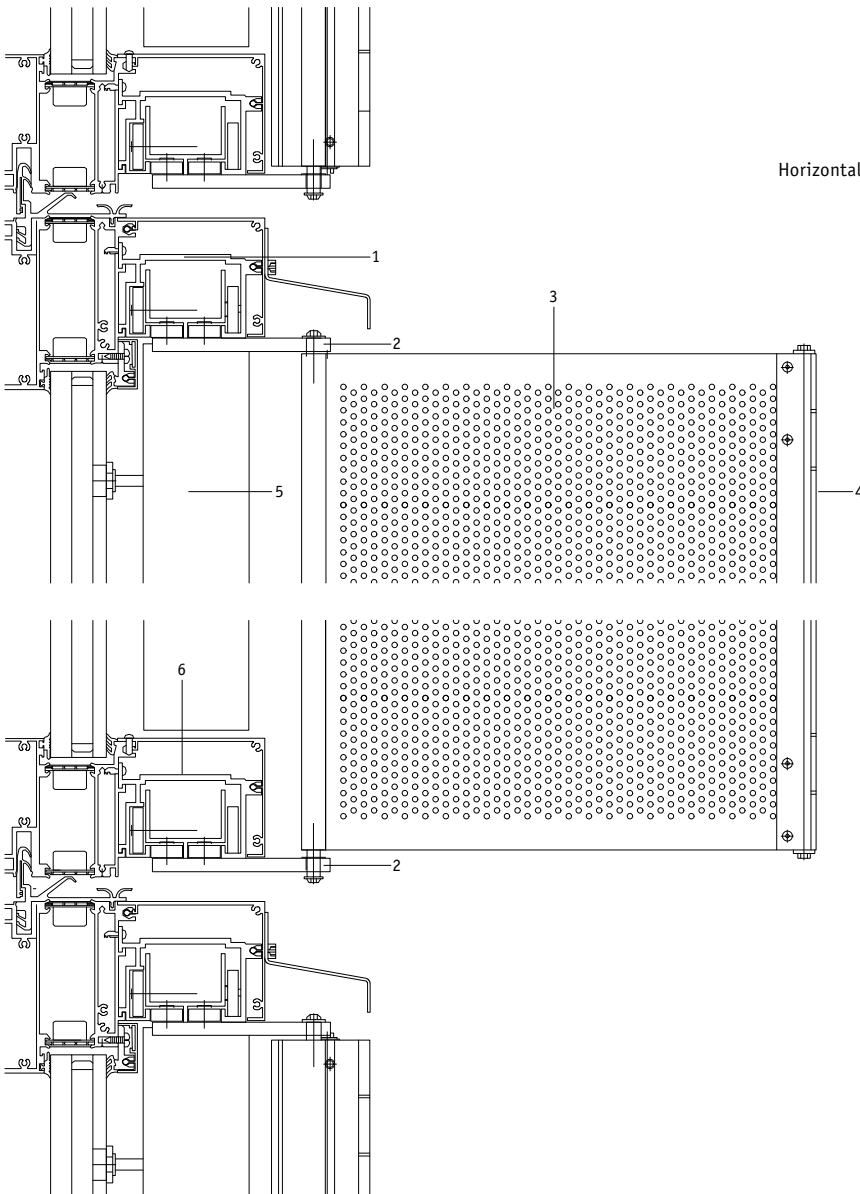

Vertical section, folding sliding shutters in open position, 1:4



Folding sliding shutters when closed



## Al Bahr Towers

Abu Dhabi, United Arab Emirates (UAE), 2012  
AHR

The 25-storey twin skyscrapers of the Al Bahr Towers are among the most environmentally friendly towers in the Persian Gulf. Conceived as part of the Abu Dhabi 2030 Plan and built in Abu Dhabi City, their design aims to make use of state-of-the-art technologies while respecting the architectural heritage of the region.

The overall form of the towers wraps around a central core and tapers gently towards the top and bottom. To provide sustainable energy, the buildings are clad with photovoltaic cells at an optimum angle and the tops of the buildings are slanted to maximise solar yield. Enclosing the buildings on inside of the external skin is a honeycomb-like structural framework designed to optimally distribute the loads acting on the buildings.

The most striking aspect of the buildings, however, is an outer honeycomb-like structure that draws its inspiration from mashrabiya, the traditional lattice screens used to shield the interior of Arab dwellings against direct sunlight and to provide privacy. On the towers, the cream-coloured screens comprise 2099 individual translucent elements that act as a solar shading system. Wrapped around the west, east and south sides of the towers, the computer-controlled elements can open and close individually in response to the position of the sun.

Each honeycomb cell consists of six movable elements, each of which consists of six translucent triangular panels. The individual elements fold (and unfold) by means of a linear drive mechanism, causing the screen to open and let light through. The

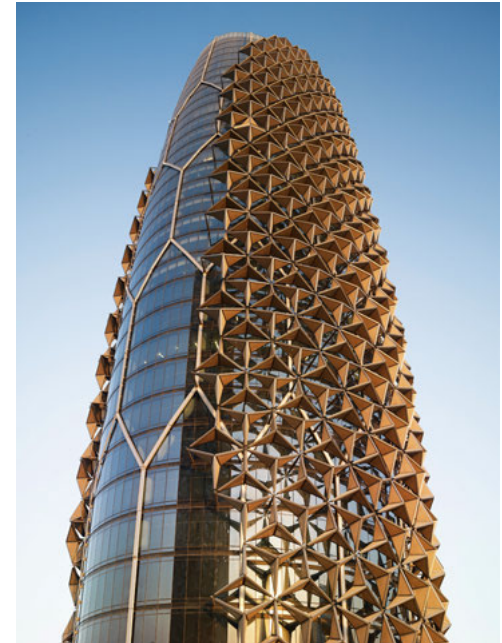

Exterior view

opening and closing mechanism resembles that of an umbrella. The large number of honeycomb cells gives the towers a dynamically changing appearance. This facade solution has been able to reduce power consumption by 50% compared with conventional high-rise buildings.

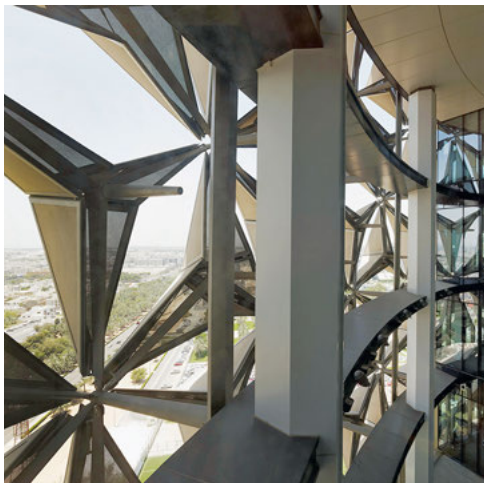

Facade elements from inside

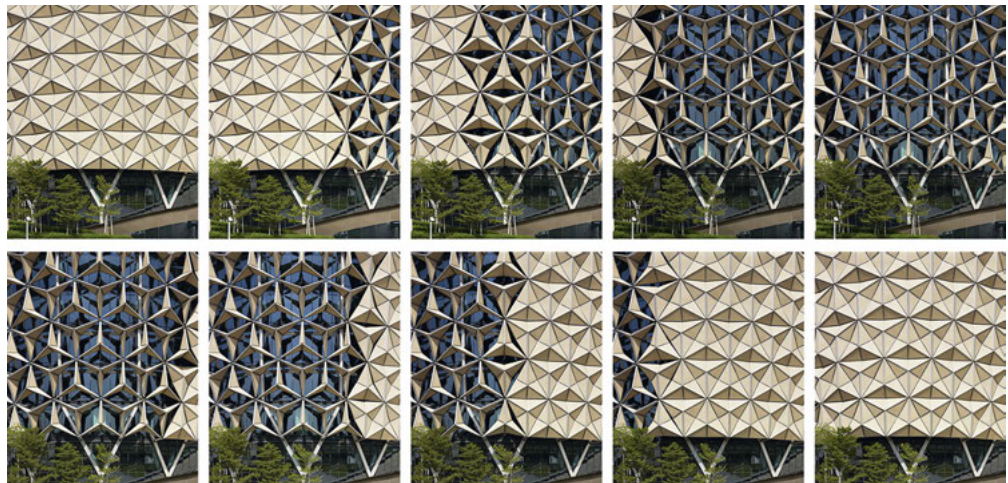

Opening and closing motion of the facade elements

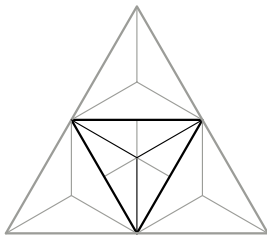

0:00

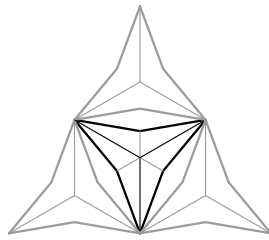

0:30

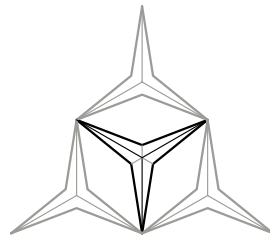

1:00

min:sec

Dimensions L x H = 3 x 3 m Number 2099

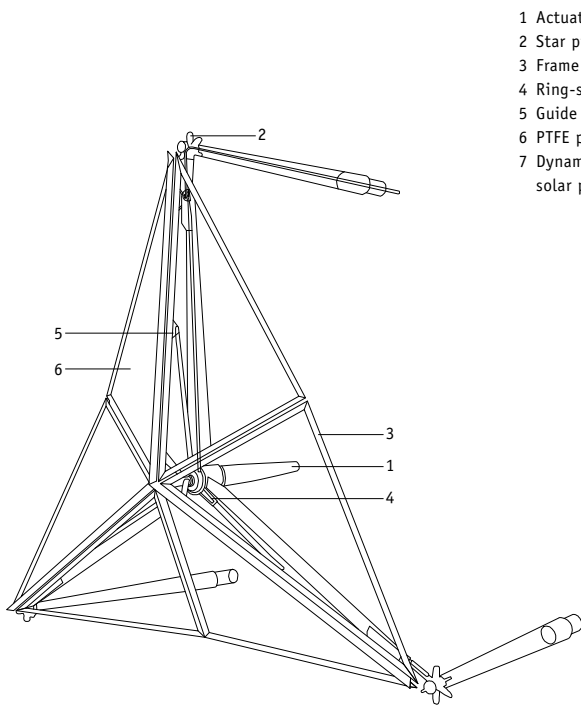

- 1 Actuator drive
- 2 Star pin connector
- 3 Frame profile
- 4 Ring-shaped connection
- 5 Guide arm
- 6 PTFE panel, translucent
- 7 Dynamic "mashrabiya" - solar panel

Axonometric projection of one-sixth of a module of the outer sun screen

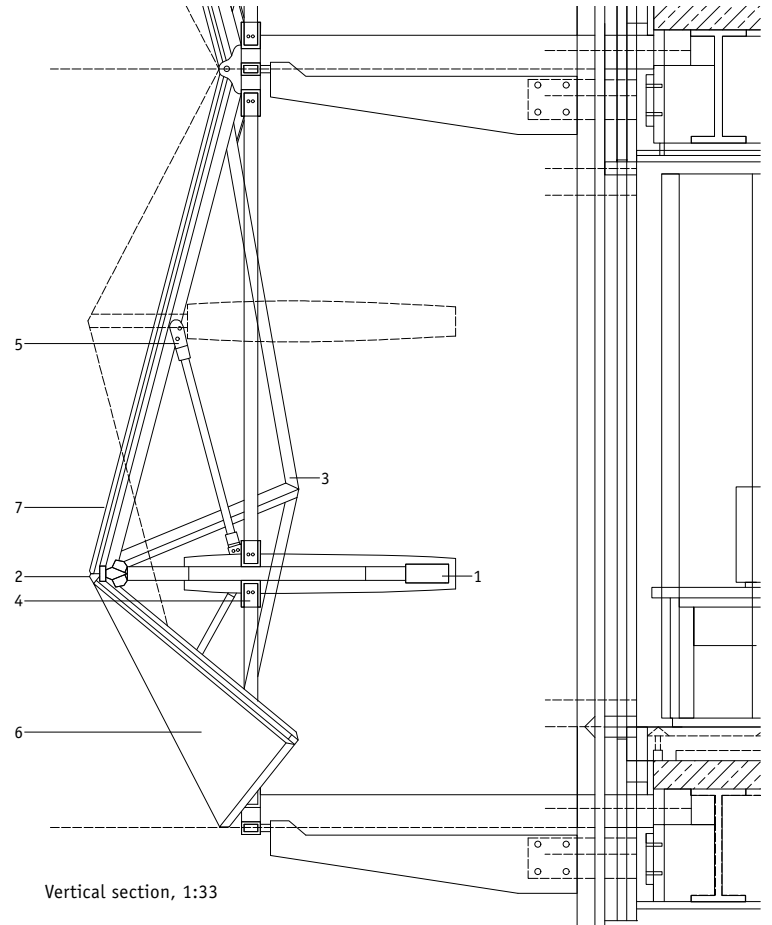

Vertical section, 1:33



Opening sequence of a sun screen module

Fold



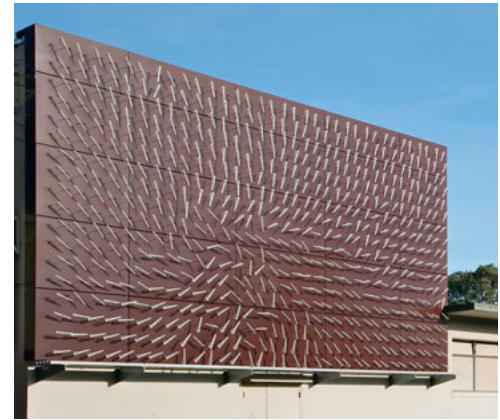

Installation on the facade of the Randall Museum in San Francisco, California, USA



## Windswept

San Francisco, USA, 2011  
Charles Sowers

Windswept is an architectural installation by the artist Charles Sowers on the south wall of the Randall Museum in San Francisco. Commissioned by the San Francisco Arts Commission and designed from 2009 to 2011, the sculpture was installed in just four days and still exists today. As much an aesthetic spectacle as a scientific instrument, Windswept makes it possible to observe the complex interactions between wind and buildings. Gusts blowing through the sculpture make visible the complex and constantly changing interactions of the wind with the building and its surroundings.

The installation comprises 25 brown metal panels mounted on the side of a building measuring 10.60 × 6 m. A total of 612 wind direction indicators made of anodised aluminium are mounted on the panels parallel to the wall at 30 cm intervals. Each wind direction indicator rotates on a freely movable stainless steel axle attached perpendicular to the wall. To reduce their weight and allow movement even in light winds, each pointer has circular cutouts. A 30 cm long pointer including the axle and connecting pieces weighs just 51 g.

The indicators are balanced in such a way that they remain in their last position when there is no wind, providing a snapshot of the last gust of wind. As such, they convey movement even when not moving. The images that result are reminiscent of vector field diagrams and the installation serves as a real-time instrument that employs kinetics to show the interaction of location and wind.

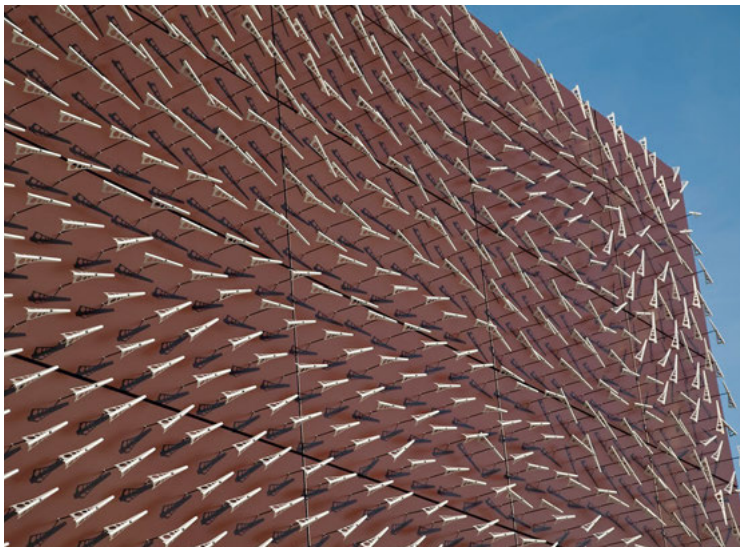

Wind-generated facade patterns



Facade with wind direction indicators



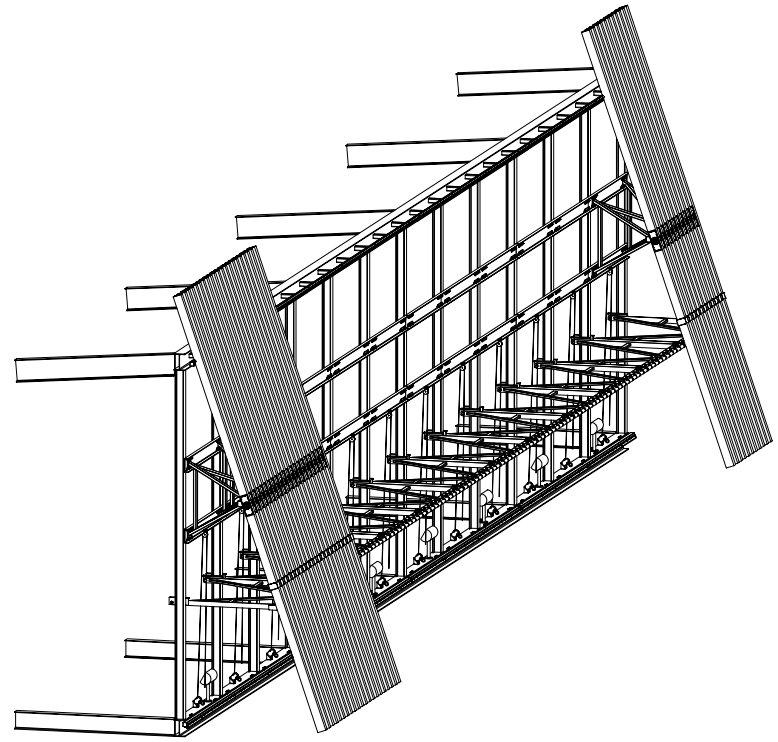

Axonometric projection of the 21 m long facade installation

## Wave Wall

Livingston, USA, 2006

Charles Sowers, Shawn Lani and Peter Richards

Wave Wall was created as a collaboration of three artists from San Francisco, Charles Sowers, Peter Richards and Shawn Lani, together with scientists from the Laser Interferometer Gravitational-Wave Observatory (LIGO) of the California Institute of Technology, project architects EskewDumezRipple and the engineering firm High Precision Devices in Boulder, Colorado. Commissioned by LIGO shortly after Hurricane Katrina, the Wave Wall and its designers were awarded the AIA New Orleans Design Award in 2007.

The installation consists of 122 pendulum rods mounted vertically on a building facade. Suspended at a height of 2.40 m above street level, they stretch the length of a 31 m long glass frontage. The 8.20 m long rectangular pendulums are made of aluminium and have a cross section of 10 × 15 cm. Their movement can result from the wind and also be controlled by a cable drive system. Coupled to their respective neighbours via two magnets, wind causes the movement of the pendulums to ripple across the entire surface in waves, much like a large piece

of fabric moving in the wind. The pendulums can reach a maximum outswing angle of 32°. At wind speeds of more than 28 km/h, the force of the wind exceeds that of the magnetic coupling and the wave-like motion breaks down, becoming more chaotic. If wind gusts become too strong, exceeding 40 km/h, the cable drive mechanism cuts in and secures the pendulums automatically in an upright position.

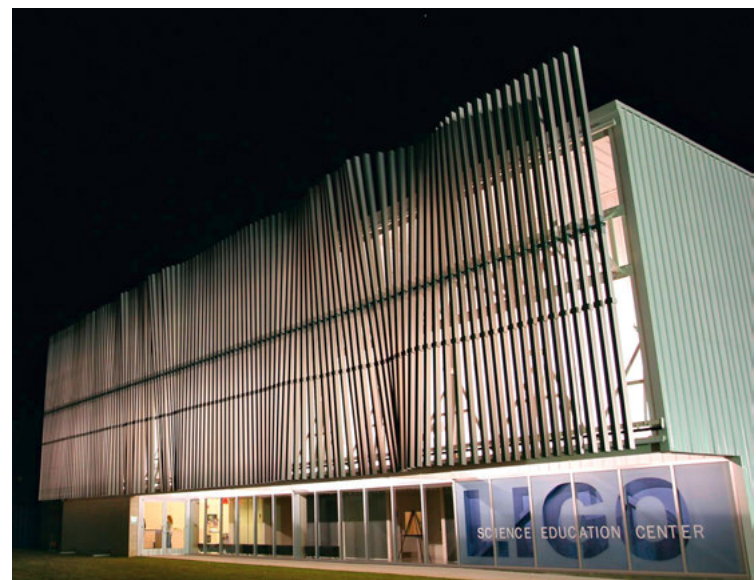
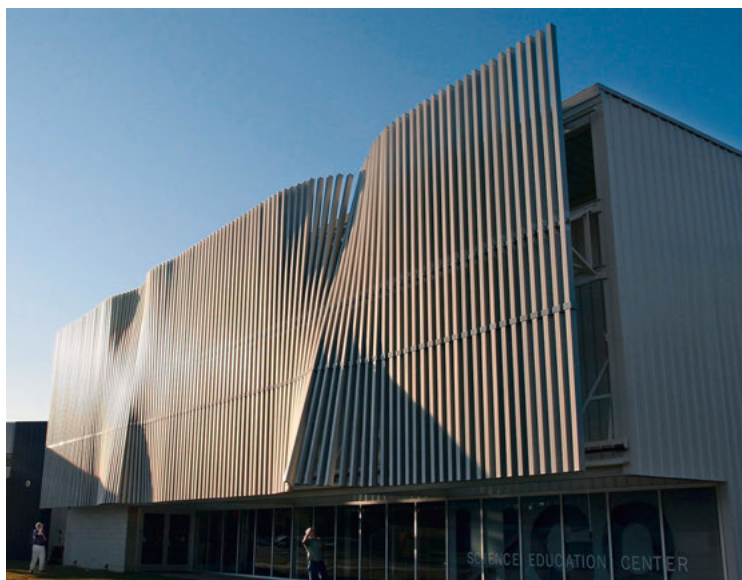

Facade during the day and at night



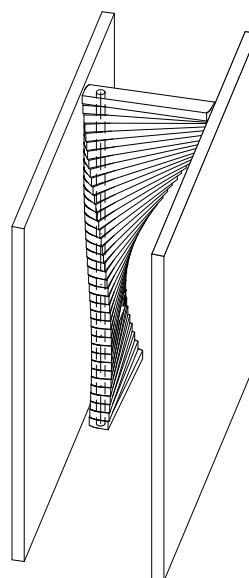

Axonometric projection of door situation and axis of rotation



## Curtain Door

Surat, India, 2008  
Matharoo Associates

The Curtain Door is the main entrance to a residence with a concrete structure in Surat.

The custom-made locally assembled door is made of solid Burmese teak wood and closes an opening 5.20m high and 1.70m wide. The door leaf is composed of 40 horizontal solid wooden segments measuring  $170 \times 12.50 \times 25$  cm, each with an individually cut slot through which a wire runs, threading together the segments as if on a chain. 160 pulleys and 80 ball bearings are built into the wooden segments to ensure the elements slide over

each other smoothly. At the end of the wire, a counterweight, which hangs inside a hollow tube that serves as the pivot axle for the door, acts as a gentle self-closing and locking mechanism for the door. Working in unison, the composition of parts transforms the flat plane of the door into a sinusoidal curve with one effortless push.

The wooden segment with the widest swing defines the distinctive curvature of the door and is fashioned complete with handles from a single piece of wood, maintaining the material integrity of the

door and obviating the need for additional metal handles. A second wooden segment incorporates the lock. Shutting out the hustle and bustle of the city, the door leads into an intriguing and intimate entrance area that warmly welcomes visitors to the house. Through its material solidity, the door establishes a clear boundary while at the same time assuming the role of an actor in the unfolding drama of the experience of entrance.



The door in the entrance corridor



Entrance area to the living room

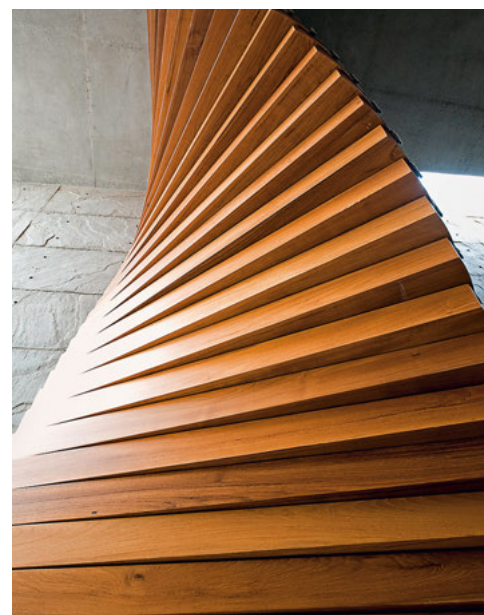

Door segments in motion





Bridge at rest

## Mobile footbridge in Stalville

Stalville, Belgium, 2004  
NEY + Partners

The bridge in the small Belgian village of Stalville spans a canal that connects the coastal town of Ostend with Ghent. Since 1571, six bridges have spanned this canal, each a reflection of the technical know-how of its time. The new, 3 m wide bridge at this point spans a canal width of 26 m. In addition to respecting the historical significance of the site, the architects also strove to find a fitting expression for the flat, rural environment, which resulted in a minimalist and lightweight design for the bridge construction.

Its innovative yet familiar appearance is the product of three design considerations with respect to

bridge typology, structure and function, as well as material optimisation. In response to the context and available technology, the architects devised a new typology of moving bridge. The basic kinematic idea maintains the same static system for the bridge structure in all three states – closed, moving and open. This approach made it possible to optimise the weight of the bridge and achieve the desired sense of lightness.

The 20 t bridge span with a trough-shaped cross section is suspended on four swinging booms which rotate about their centres by up to 87°, raising the bridge as they move. A hydraulic system within the

loadbearing portal frames controls the degree of pivot of the booms about the turning point by exploiting the weight difference between the bridge section and the counterweights. Alongside their structural function, the vertical webs on either side of the bridge span act as balustrades. To minimise weight, the central part of the balustrades were realised as a mesh structure.



Opening sequence of the swing bridge

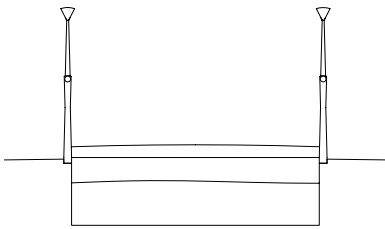

0:00

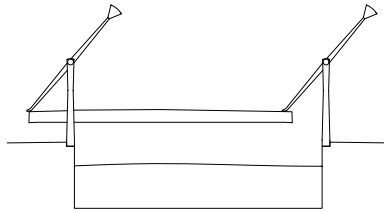

0:45

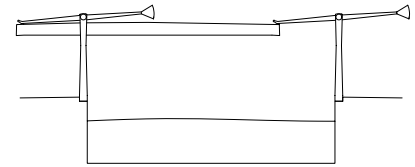

1:30

min:sec

Dimensions  $W \times L = 3 \times 26$  m Number 1 Weight per element 20 t bridge section, 20 t counterweights and 15 t lever arms

- 1 Axis of rotation with hydraulic drive
- 2 Lever arm, sheet steel, central pivot, 6.50 m, maximum rotation 87°
- 3 Counterweight 15 t
- 4 Sheet steel bridge parapet, CNC milled
- 5 Bridge section with diagonal cross-brace,  $3 \times 1.20 \times 26$  m, sheet steel,  $10 \times 400$  mm



Counterweight (lever arm)



Bridge section (lever arm)

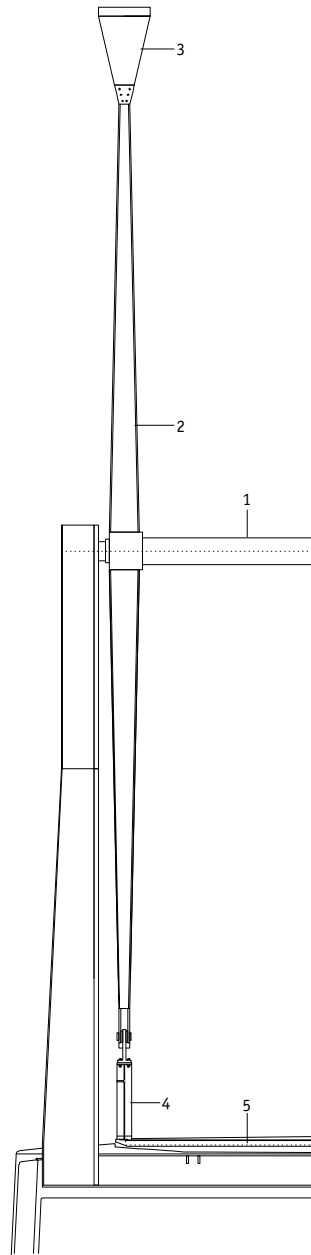

Cross section, 1:100

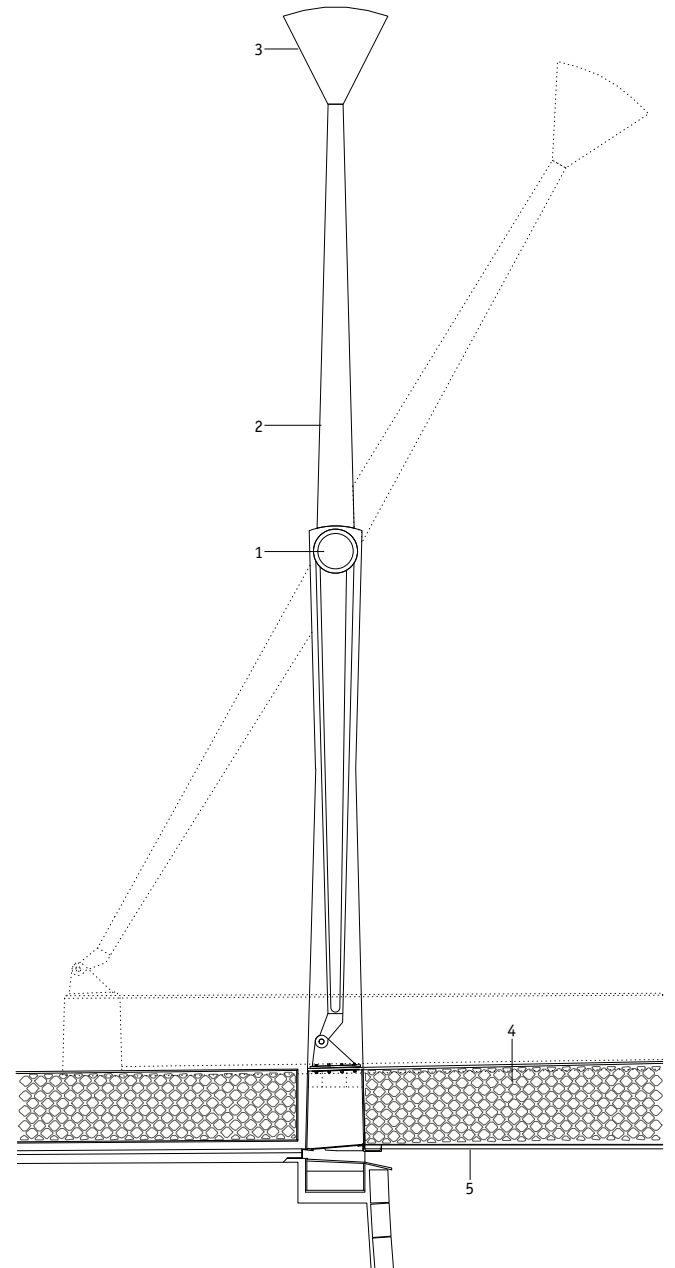

Longitudinal section, 1:100

Swing





Closed bridge

## Lower Hatea River Crossing

Whangarei, New Zealand, 2013  
Knight Architects

The 265 m long and 17 m wide estuary crossing was designed by Knight Architects as a direct commission in 2011 and opened in 2013. The car and pedestrian bridge provides a direct link between the city and William Fraser Memorial Park on New Zealand's North Island. As a key element of the state highway network, it was built to relieve the city centre and improve access to Whangarei Heads and the airport. The bridge affords a permanent minimum clearance for regular waterborne traffic and a 25 m wide central opening section to allow vessels

taller than 7.50 m to pass. The bridge design is intended as an expression of Maori art and culture.

The structure is a rolling bascule bridge in which the entire bridge deck lifts in a movement similar to that of a rocking horse. The main advantage of this is that rather than opening at a steep angle, the bridge opens with a backward movement that operates faster than a regular bascule. The steel box girders are shaped to facilitate an efficient rocking movement and raised beams interpret the motif of a traditional fish hook, and give the bridge its name

in the Maori language: Te Matau à Pohe (the fish hook of Pohe).

The counterweights incorporated at the top of the J-shaped hollow beams help to balance the weight of the roadway. The difficult site conditions, which include shallow tides, required the use of a hybrid construction of concrete piers, a slender concrete deck of precast elements and steel beam supports. The lifting force is provided by hydraulic cylinders and electric pumps. They keep the construction in balance while it rolls on a toothed rack.

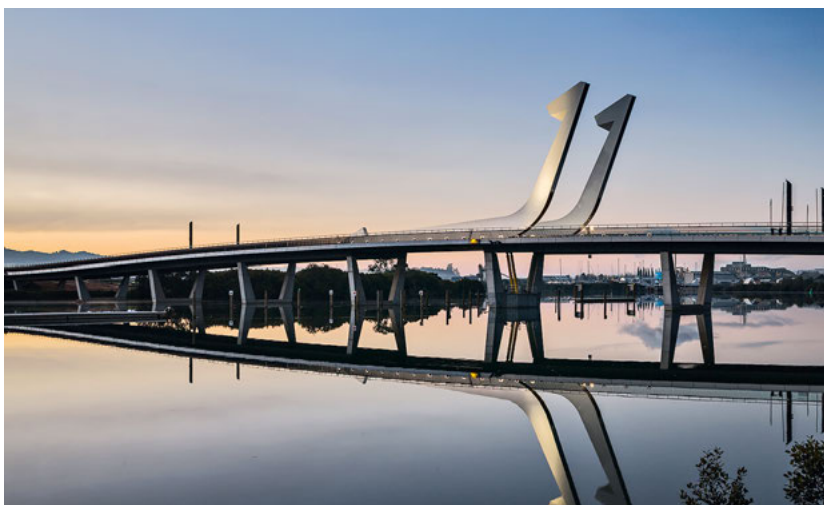

Side view of the bridge



Hydraulics and pin connection



Underside of bridge arm and rack





Aerial view of bridge in lowered position



## Merchant Square Bridge

London, UK, 2014  
Knight Architects

The 20 m long moving footbridge at Merchant Square in Paddington, London, was designed by the bridge specialists Knight Architects and structural engineers AKT II following an invited design competition in 2012. The brief called for a piece of architecture that would enhance the public realm of the waterfront areas. The bridge opens three times per week, together with the nearby “Rolling Bridge” designed by Heatherwick Studio.

The design concept is compellingly simple and consists of a 3 m wide cantilevered deck comprised of five parallel steel beams. Hinged on one side at its north end, the bridge is raised using hydraulic jacks.

The five steel “fingers” open in sequence, with the first rising to an angle of 70° and the last achieving the required clearance over the canal of 2.5 m high by 5.5 m wide at mid-channel. Sculptural counterweights of concrete-filled steel containers provide balance to each of the five moving leaves, helping to minimise the energy required to move the structure.

The counterweights are dimensioned to support the system optimally while ensuring that the bridge can be lowered by the force of gravity alone. To ensure smooth movement, the five steel beams of the deck had to be manufactured very precisely with low tol-

erances. When lowered, they create a flat, virtually seamless walking surface.

The individual sections were set up in bespoke jigs, which were used to control the critical dimensions and limit distortion caused by the welding process. The top surface of the steel beams is finished in a durable, non-slip epoxy and aggregate finish to provide a highly durable protective surface. Each of the five beams is raised by a relatively small hydraulic cylinder driven by a single motor located in the basement of the adjoining building. Like the rotational bearings, they are housed in a concrete sub-structure below ground.



Bridge in raised position



The counterweights serve as a design element



Hydraulic cylinders for raising and lowering the bridge

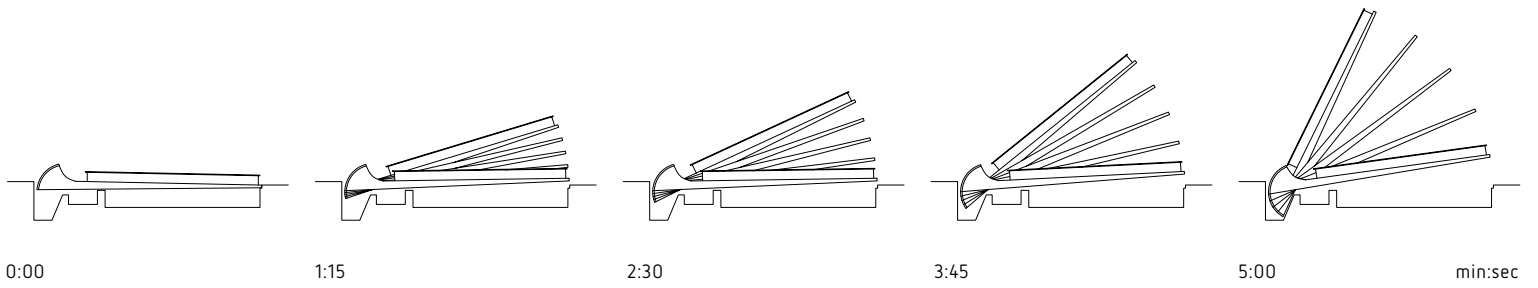

Dimensions  $W \times L = 3 \times 27.50$  m Number 5 Weight per element 6 t (counterweights filled with concrete: 6.9 t, 7.2 t, 7.7 t, 8.1 t, 8.5 t)

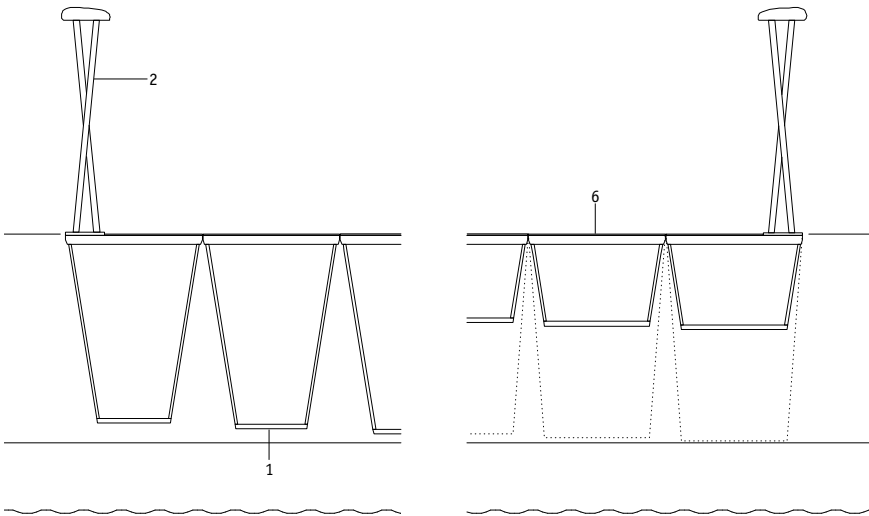

- 1 Bridge section, hollow trapezoidal box beam, steel, 27.50 x 0.60-0.30 m
- 2 Bridge balustrade, crossed lattice of steel bars with wooden handrail
- 3 Hydraulic cylinder 110 mm, driven by 2 x 15 kW batteries
- 4 Pivot bearing
- 5 Counterweight, steel body filled with concrete
- 6 Bridge surface, non-slip durable epoxy resin finish

Cross section through the bridge balustrade near the pivot and near the tip, 1:40

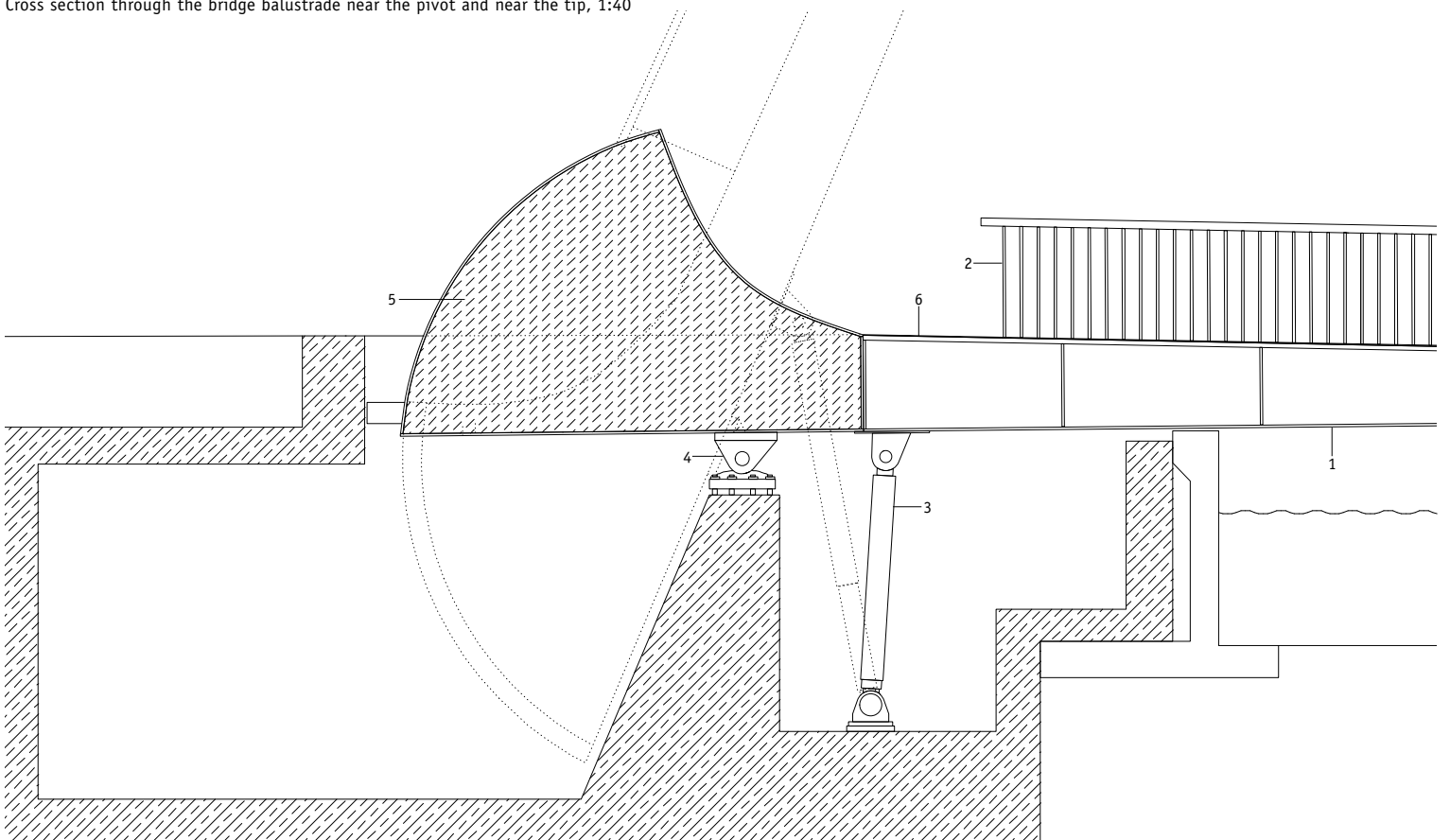

Longitudinal section through the pivot end of the bridge showing hydraulic cylinders and counterweight, 1:50



## “La ville molle”

Bourges, France, 2010  
Atelier Raum

“La ville molle” is an experiment developed by the School of Fine Arts and the Regional Fund for Contemporary Art (FRAC Centre-Val de Loire) in collaboration with the town of Bourges and the local district council. The work of art was created by Atelier Raum architects during their residence at the Galerie La Box at the École nationale supérieure d’art in Bourges, France. It questions the hardness of the city and the ability of the ground to adapt and provide unique benefits as well as to enable unusual situations. The work of art, which looks as if a plastic cushion has been slipped beneath the

paving, alters our relationship to the familiar and to the city.

From a distance, the installation seems nothing more than a substantial hump in the ground. As one approaches and then walks over it, one senses the ground move beneath one’s feet and becomes aware of the grid of small paving stones and grooves that structure its surface. The work of art transforms a small, mundane courtyard into a space of stimulation and interaction, turning a comparatively simple object into an interesting architectural commentary that has the potential to add interest and

elevate the importance of the many forgotten corners of today’s urban environments.

The art installation comprises an air-filled cushion and paving stones. The cushion lies in a gravel bed to prevent the construction displacing sideways. To prevent entirely uncontrolled movement, the paving stones are affixed on five sides – to the cushion and to their neighbours – with Velcro. As a consequence, the structure reacts to weight as a compact whole despite its many constituent parts.

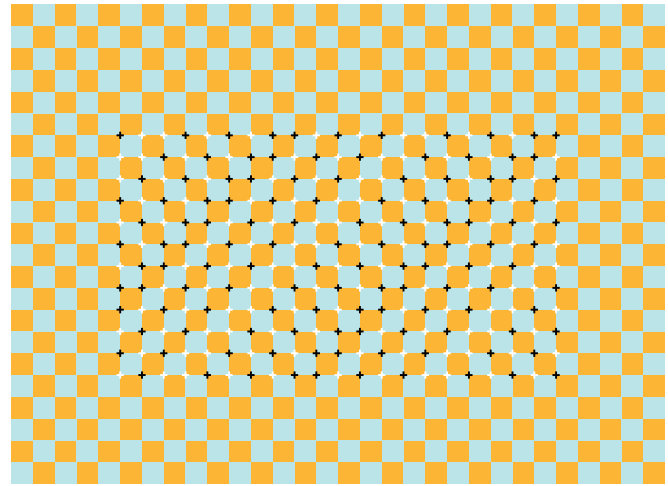

Installation concept

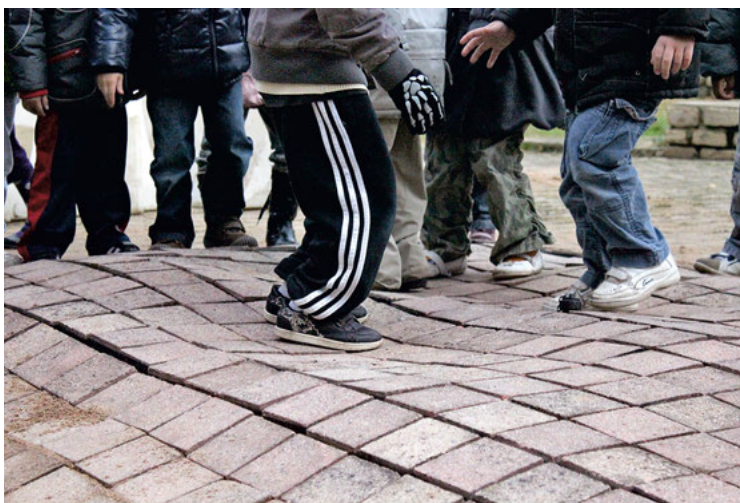

Installation in daily use



View of the paving stones in motion

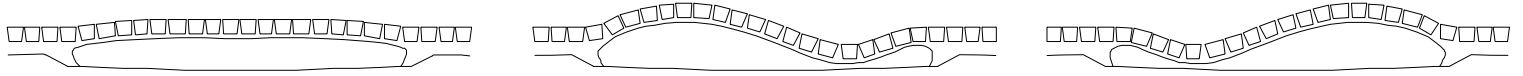

Dimensions  $W \times L = 3 \times 3 \text{ m}$  Number 1 Weight per element 1 Drive Movement depends on position of users

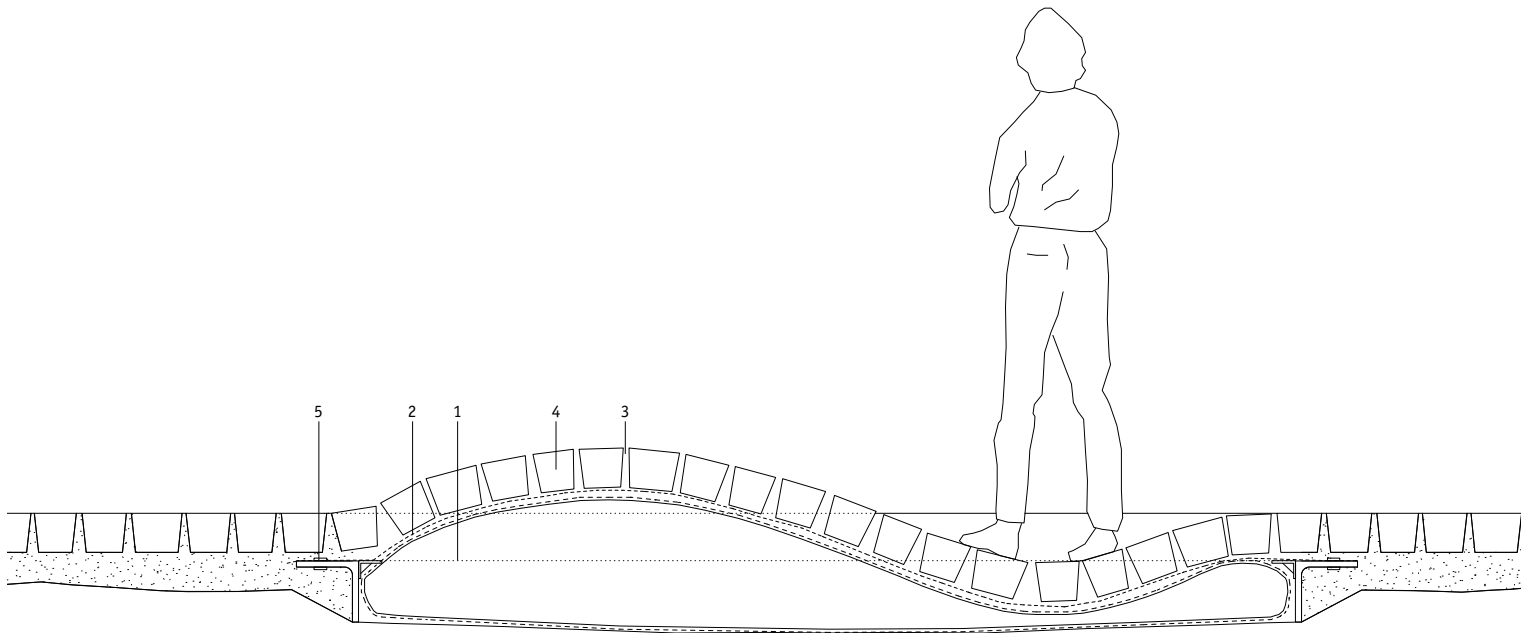

Cross section in motion, 1:25

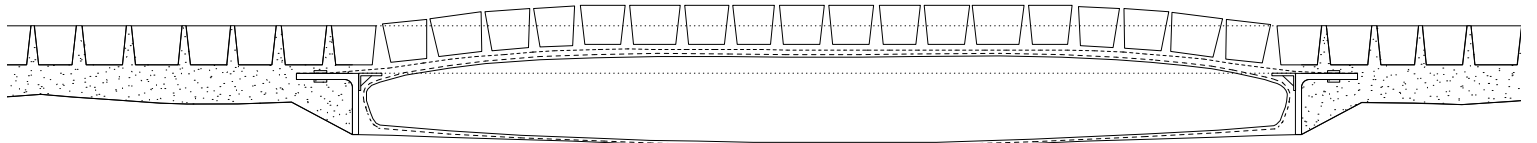

Cross section at rest, 1:25



Surface finish

- 1 Flexible water tank in gravel bed
- 2 Protective layer to prevent damage to air cushion
- 3 Velcro strips for fixing paving stones
- 4 Paving stones,  $10 \times 10 \times 6 \text{ cm}$ , fixed with Velcro on five sides
- 5 Steel edging profile

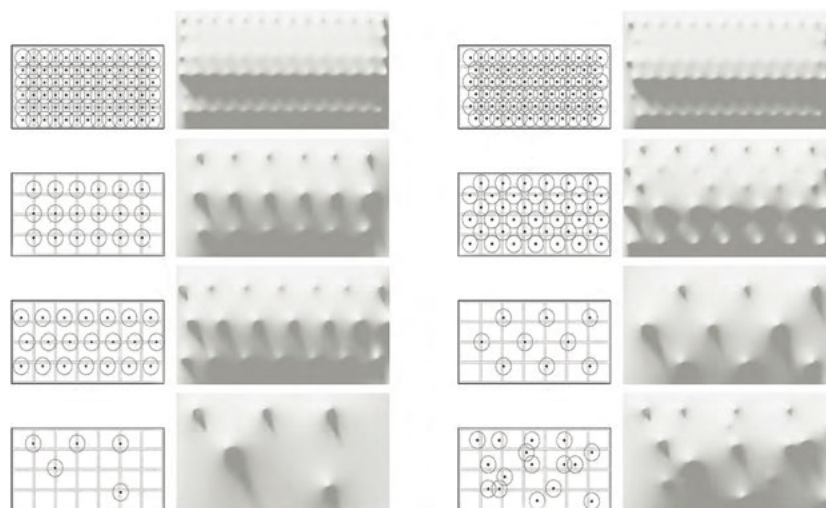

Possible topographies of the kinetic installation

## Kinetic Wall

Venice, Italy, 2014  
Barkow Leibinger

The Kinetic Wall is a prototype, developed by the architecture firm Barkow Leibinger for the 14th International Architecture Biennale in Venice, which revisits the utopian dream of an architecture that can move, as formulated in the age of modernism. It marks the culmination of the evolution of wall constructions shown in the Wall Room of the central Biennale exhibition entitled “Elements of Architecture”, which also includes walls made of stone, brick, wood and glass. Electrically driven rods extend and retract to transform a wall covered with an elastic and translucent synthetic fabric into a topographical surface of

peaks and valleys. The movement transforms the narrow corridor between the Kinetic Wall and an adjacent glass wall into a dynamically fluid space of changing width that gives the visitors an immediate sensory and physical experience of space. Its digitally controlled choreography enables innumerable configurations of surface patterns, which emerge slowly, then recede, changing endlessly. The fabric is stretched over the wall in two layers: as the layers slide over each other, they create a moiré effect, intensifying the visual impression and creating a second, ephemeral level of movement. The fabric is stretched over a lightweight timber

scaffolding that conceals the mechanics within the depth of the wall. When the surface is mechanically activated, an extensible “poché” results that expresses a new kind of material thickness and physicality.

While the Kinetic Wall has a distinct front and back, the movement of the surface is visible from both sides. It offers a new perspective of an alternative future architecture of both natural and synthetic or recycled materials that is both materially and spatially dynamic.



Front of the installation



Rear of the installation

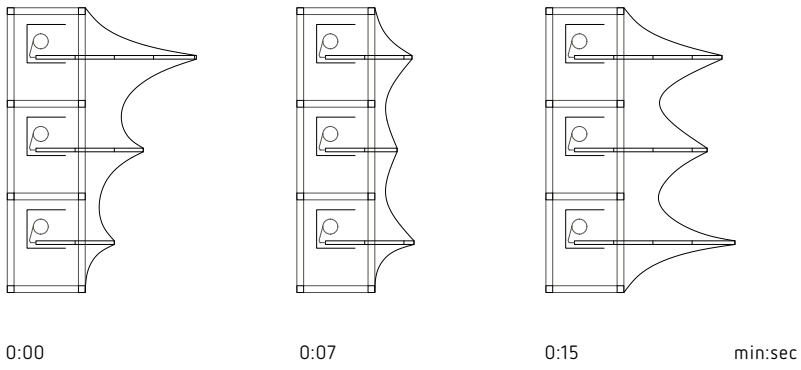

Dimensions L x W x H = 6 x 0.80 x 3 m Number 18

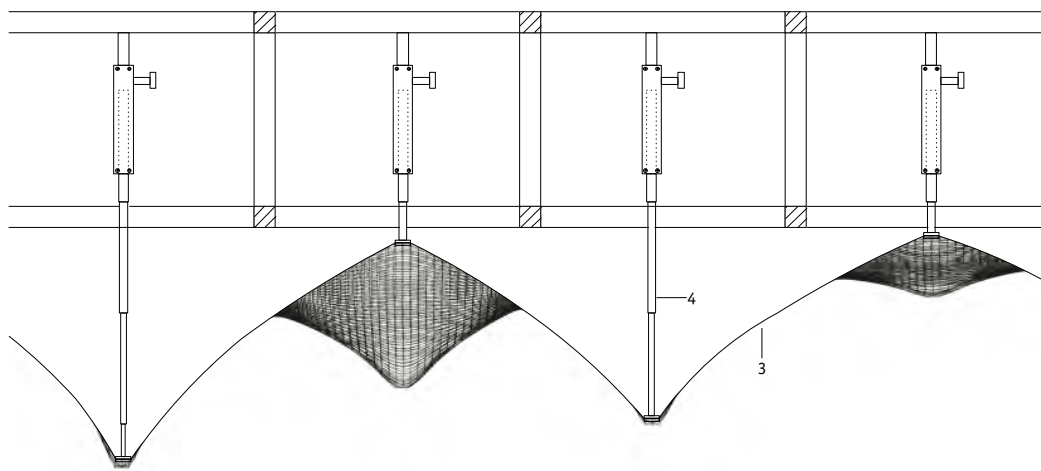

Floor plan, 1:33



Side view

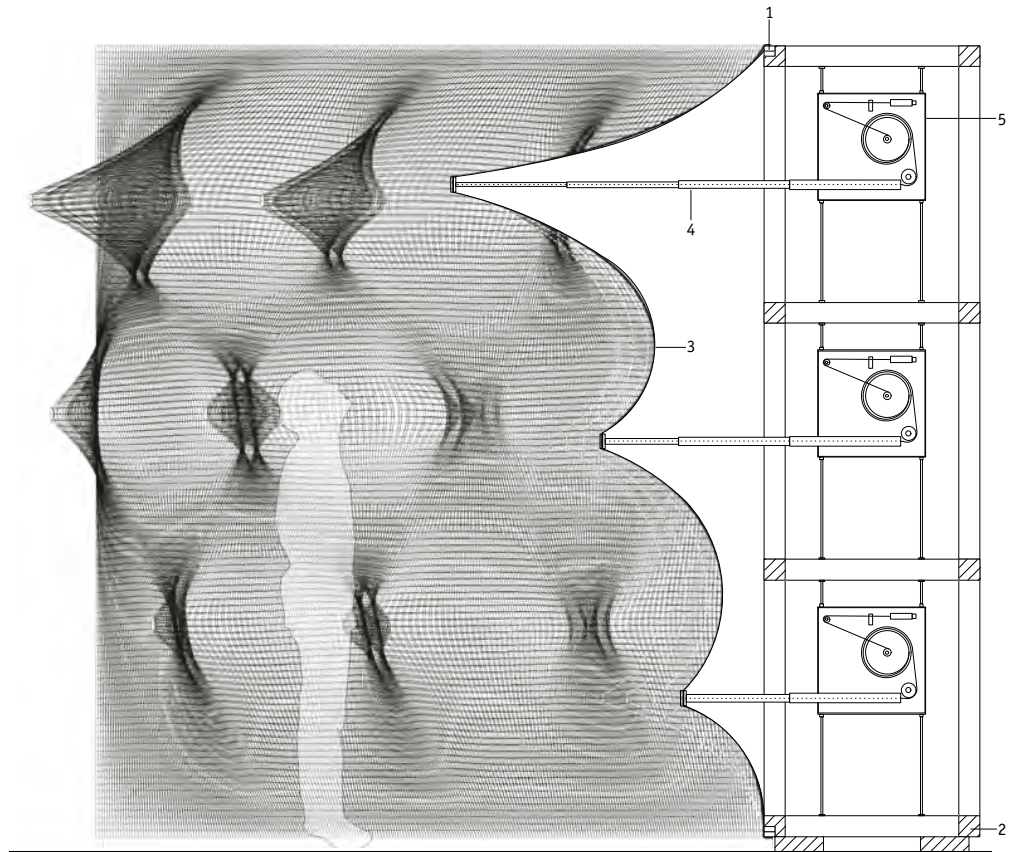

Cross section, 1:33

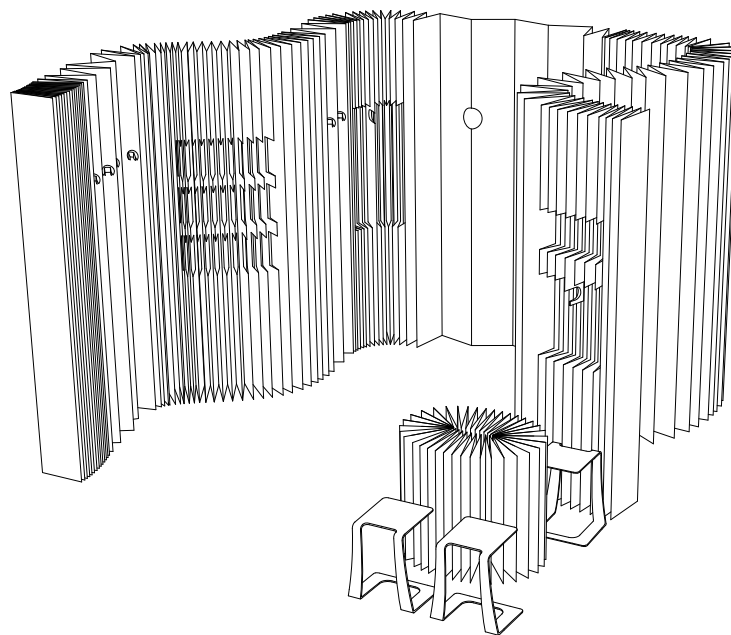

Axonometric projection of the pleated wall in situ

## Bezier Concertina display

Paris, France, 2017  
Stacklab

Bezier Concertina is a paper-based display system designed and fabricated by the design studio Stacklab in Toronto and installed in Paris. The brief was to design a display system for a line of clothing and leather goods, but the specific challenge was to develop a solution that would achieve the more pragmatic goals of being self-supporting, cost effective, compact and lightweight.

Bezier Concertina consists of a single curved display wall made of folded paper, which occupies the perimeter of an approximately 4 × 4 m showroom and presents the merchandise as shop windows to pass-

ing pedestrians on the adjacent busy street. Given the cost factor and logistical constraints, the design team chose to work with a single material: 1.5 mm thick cardboard. Inspired by the corrugations in the structure of the cardboard, the paper sheets were scored and folded in a concertina to create a rigid structural system. This strategy resulted in a self-supporting wall section that became the basis for the display system.

Once erected, the display circumscribes the interior with a curvilinear accordion-like structure. The fold intervals vary to create visual interest through

changing areas of high and low fold density, and to allow different display configurations. The denser sections serve as shelves for the display of leather goods such as shoes and bags while the less dense areas have intricate cut-outs that can be folded to form rigid hooks for hanging clothes.

An accompanying table was also made using the same material principle. The Bezier Concertina display underlines the simple yet refined aesthetics of the fashion collection.



Entrance space



Cut-outs serve as shelves (centre and left)

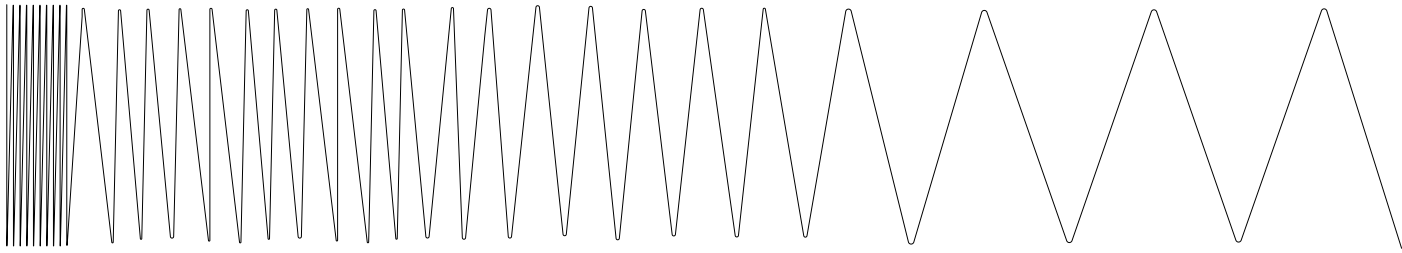

.....  
**Dimensions** L = 122 m **Number** 1 **Weight per element** 100 kg **Drive** Manual (bent or folded by hand)

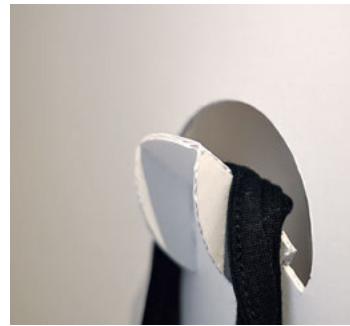

Hook, semicircular cut-out



Hook in the fold

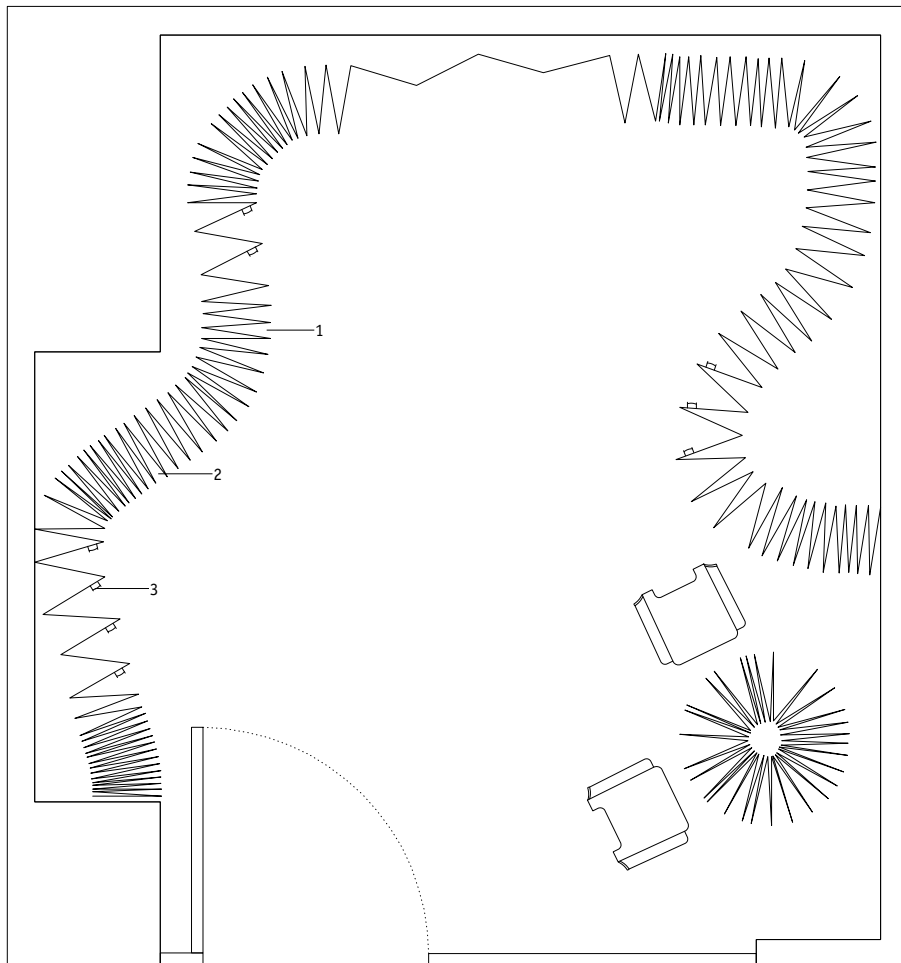

Floor plan of shop, 1:33

- 1 Corrugated cardboard 1.50 mm, white, scored and folded at 30 cm intervals
- 2 Shelves formed by cut-out sections of folded wall
- 3 Hooks, cut and folded

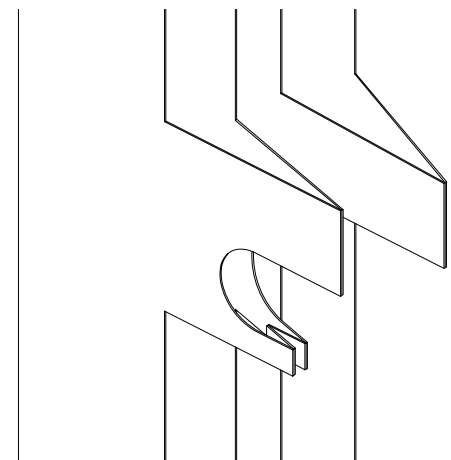

Hooks in the fold



View from the road with 24 m long solar facade

## IBA Soft House

Hamburg, Germany, 2013  
 Kennedy & Violich Architecture and  
 Knippers Helbig Advanced Engineering

The Soft House was built for the IBA International Building Exhibition in Hamburg in 2013 and was the product of an IBA ideas competition. It employs a dynamic textile facade to make flexible and smart use of the sun's energy, while its solid wood construction makes it a model of sustainable construction. The row of four terraced houses is built to Passivhaus standard and employs a solid wooden construction technique formed of stacks of wooden planks from domestic sources connected by hardwood dowels to form Brettstapel panels. These can be produced and worked by local contractors. Solid wood construction is a low-carbon alternative to

conventional brickwork construction for house building.

On the outside, the Soft House is clad with an adaptable construction on which flexible photovoltaic cells are mounted. These "twisters" take the form of textile strips in front of the facade that follow the course of the sun by twisting about their axis. In addition, the residents can also control the view and degree of shade by individually controlling the twisters. On the roof, deformable panels of glass fibre reinforced plastic are mounted that adapt to the annual cycle of the sun by elastic bending. The IBA Soft House is the first implementation of this

type of flexible and adaptable photovoltaic system and, in this respect, it also is a model for future developments.

Inside the houses, the living areas can be subdivided with movable, translucent curtains that also have LEDs sewn into the fabric. These are powered by a low-voltage current supplied by the photovoltaic cells of the membrane facade. The curtains make it possible to regulate room temperature and light individually and to vary the configuration of the spacious interiors as required.

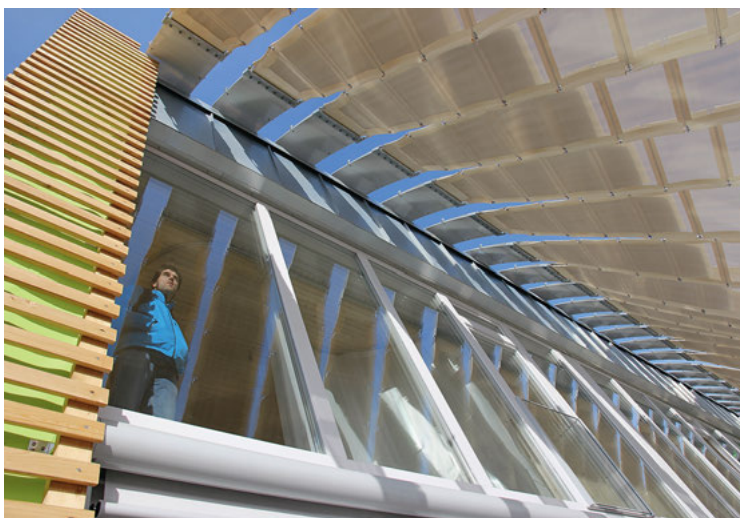

The space between the facade and the shading strips



View from above of solar shading strips and terrace

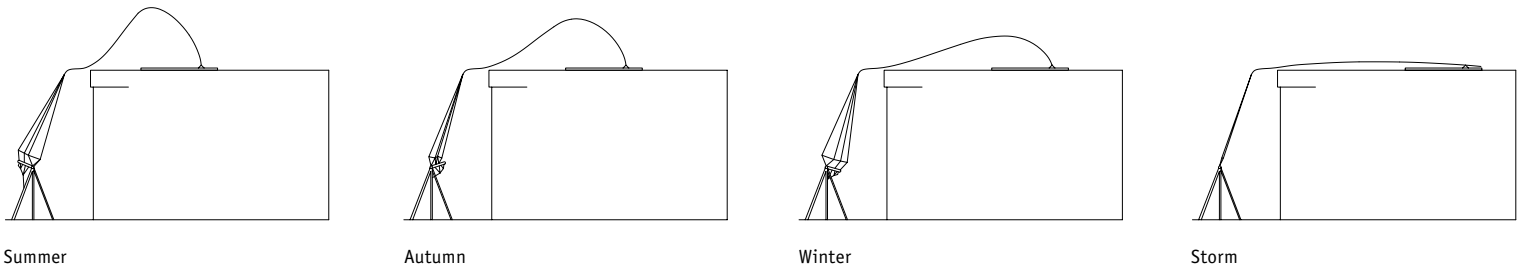

Summer

Autumn

Winter

Storm

.....  
**Dimensions** L = 6 m, W = 500 mm, Ø 10 mm **Number** 32

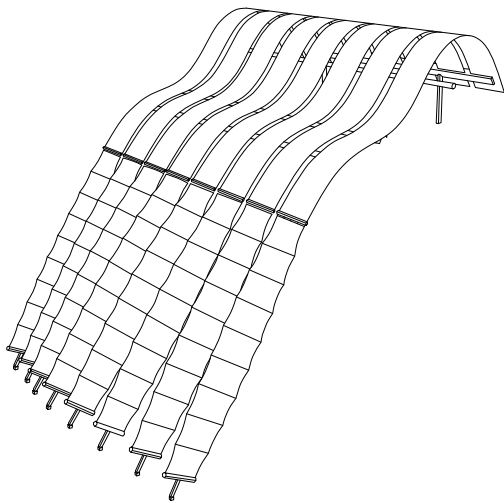

5.8 m facade section of eight photovoltaic panels

- 1 Photovoltaic panel CIGS, 400 × 50 cm, 300 W
- 2 GFRP panel 8 mm, maximum twist rotation 60°
- 3 Hybrid textile, PTFE membrane, L × W = 600 × 60 cm, maximum twist 37°
- 4 Rigid end clamping strip, steel, swivel bearing
- 5 Hydraulic rotation drive unit
- 6 Steel tube as base profile for hydraulic lines, galvanised

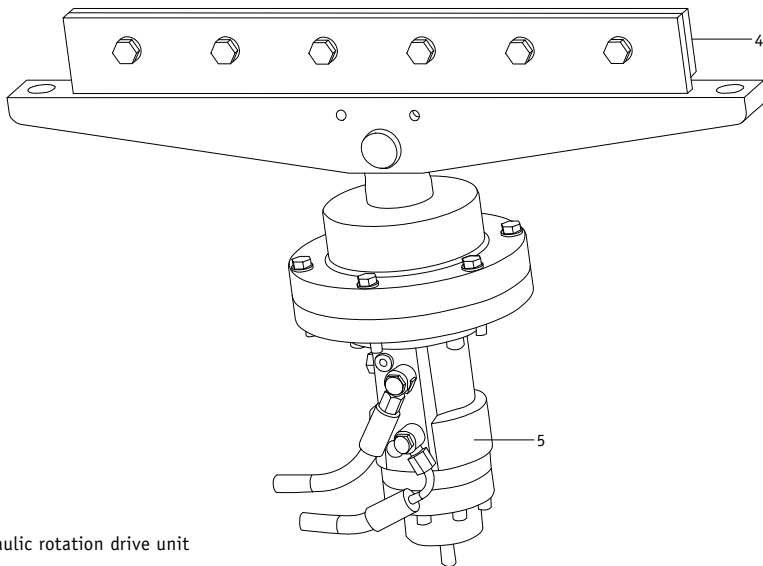
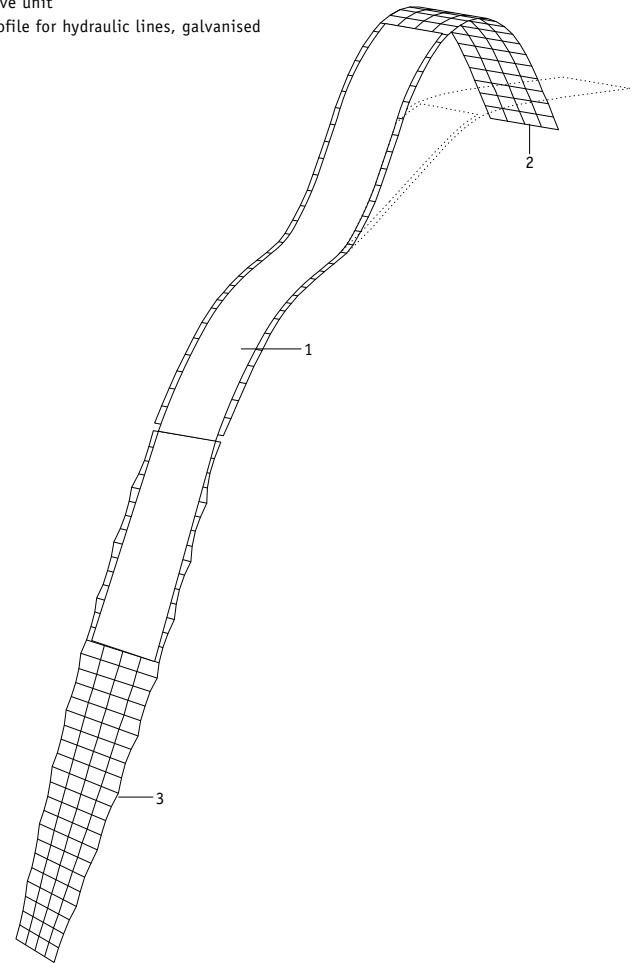

Hydraulic rotation drive unit

Membrane with photovoltaic panel

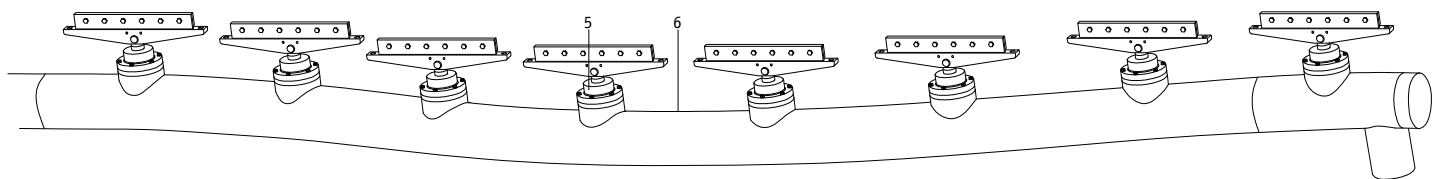

Base profile with hydraulic drive units

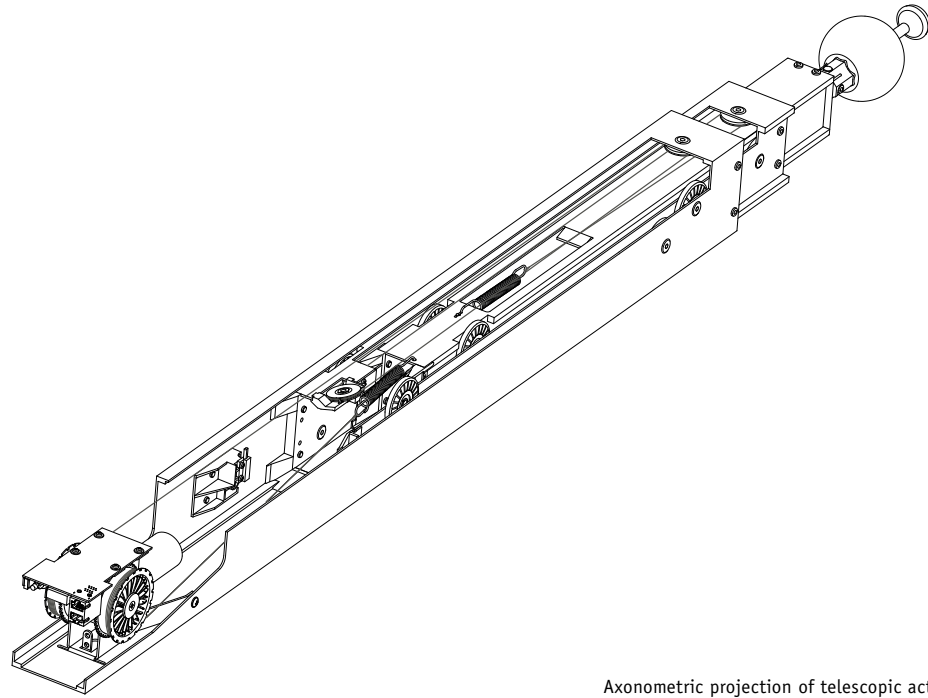

Axonometric projection of telescopic actuator cylinder

## MegaFaces

Sochi, Russia, 2014  
Asif Khan Ltd. with iArt

This kinetic facade, designed by London-based architect Asif Khan and developed by iart, can reproduce three-dimensional objects in space. Installed on the side of a pavilion at the Winter Olympics in Sochi in 2014, it was commissioned by one of the event sponsors, a Russian telecommunications network. Visitors to the pavilion could take their photo in a 3D photo booth specially developed for the project, which would then pass the data to the kinetic facade.

The facade is composed of 10,500 telescopic cylinders, each equipped with a spherical RGB LED at its

tip, which can extend by up to 2 m to recreate the faces of three visitors at a time at a height of 8 m. The effect turns the pavilion into a Mount Rushmore of the digital age: faces at 35 times their original size take shape and disappear again, morphing into new faces.

The actuators of the telescopic cylinder are connected in a bidirectional system, which enables the points to be controlled individually, and simultaneously reports back the position of the respective actuator. Each actuator is a pixel of the overall facade and can change colour as part of a colour

image or sequence of images. The challenge lay in being able to produce this effect at sufficient speed and to produce images of sufficient quality, while also being user-friendly to operate. The scanning process had to be as fast and simple as a regular passport photo machine but also produce 3D models of a high enough quality to display on the facade.



Exterior view of the facade



Detail of the facade in action

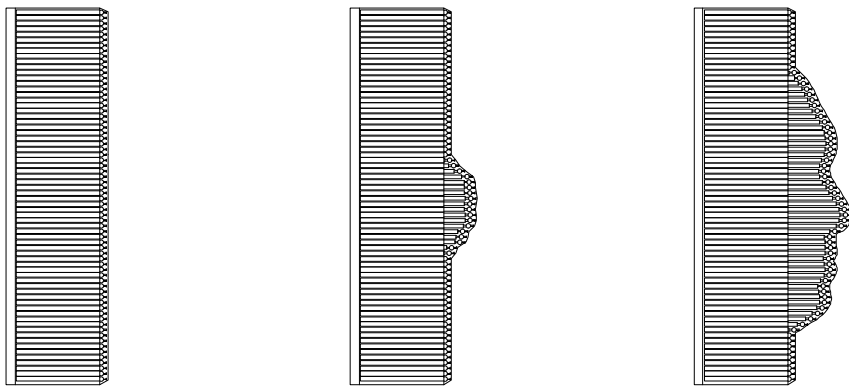

0:00

0:10

0:20

min:sec

Dimensions H x W x L = 0.10 x 0.08 x 1.98 m Number 10,500 Weight per element 10 kg

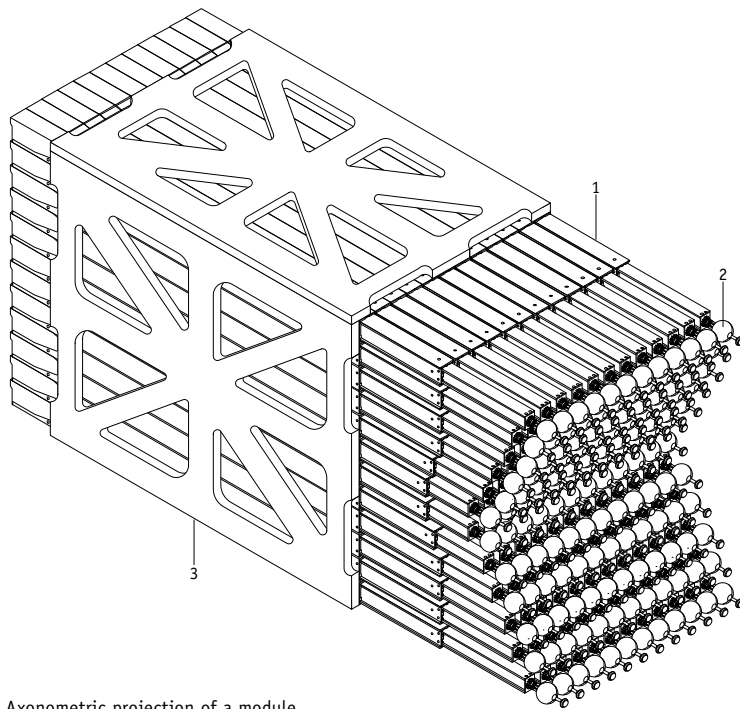

Axonometric projection of a module

- 1 Telescopic actuator cylinder with worm screw, 30 W, cable system with two pulleys at motor end, internal guide rollers for precision rod travel
- 2 LED lamp unit with glass sphere
- 3 Module housing, steel

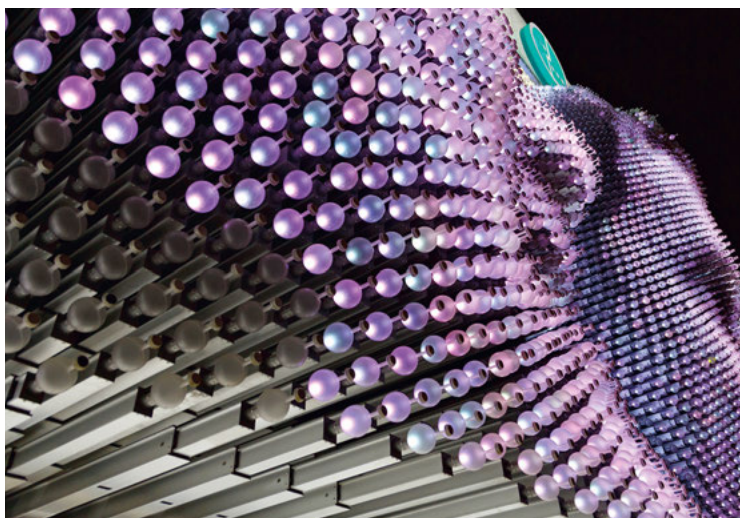

View from below of extended actuators (max. 2 m)

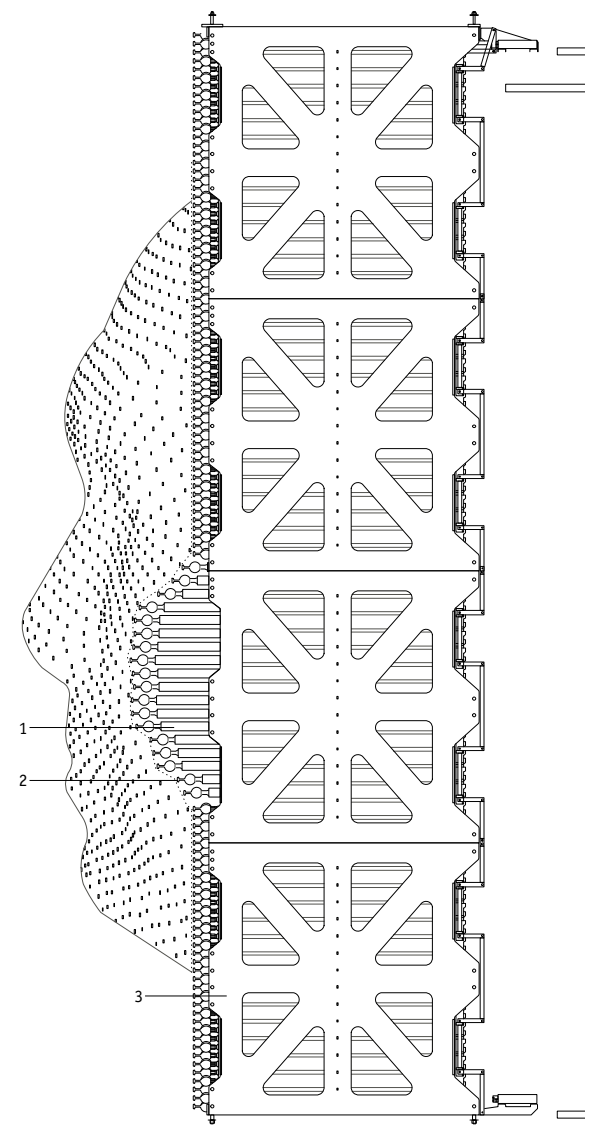

Vertical section, 1:65

Deform





Rear facade at night

## One Ocean

Yeosu-si, Jeollanam-do, South Korea, 2012  
 soma architecture  
 Knippers Helbig Advanced Engineering

The thematic pavilion for the EXPO 2012, designed by the Austrian architecture firm soma, opened in the South Korean port city of Yeosu on 12 May 2012. Commissioned by the EXPO to promote the responsible use of natural resources, the pavilion conveys its programme not through symbolic gestures but through its architecture. To this end, the architects developed a sustainable climate concept and a kinetic facade based on bionic principles. The building's design is inspired by the theme of the EXPO – The Living Ocean and Coast – and in particular the experience of the sea as both an endless surface and depth. Its continuous surfaces warp from vertical cylinders into horizontal planes, thereby creating two different exhibition areas.

In contrast to the virtual multimedia installations in the pavilion, its architecture and most notably its kinetic facade, aims to create memorable experiences by analogue means. This facade comprises a series of flexible lamellas that regulate the incidence of daylight in the foyer and the building's "best practice area". Individually controllable, they can be opened and closed in succession to create choreographic waves and patterns that ripple along the length of the building. At night, the visual effect of the open lamellas is particularly striking, thanks to LEDs fitted to the inner surface of each lamella that illuminate the adjacent one when open. The elegant opening movement of the lamellas and their gill-like appearance is a product of the elastic

deformation characteristics of the glass fibre reinforced plastic, and is inspired by the flexing behaviour of plants.

The intermediary spaces between the exhibition areas are oriented towards the prevailing wind direction to provide natural ventilation in the foyer and the "best practice area". By day, the lamellas of the kinetic facade regulate the degree of solar gain while solar panels on the roof supply power for the building's technical services.



Closed state



Open state

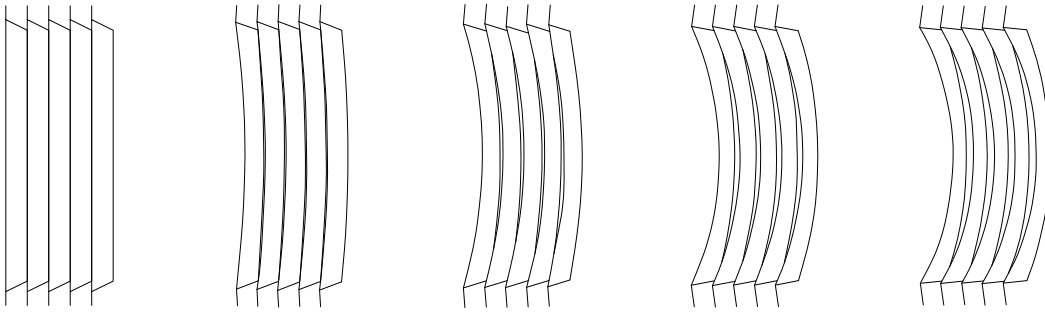

**Dimensions** Facade length = 140 m, Lamella L × W = 3–13 × 1.40 m, 9 mm thick **Number** 108 **Weight** Variable per element **Speed** Variable **Drive** Digitally controlled

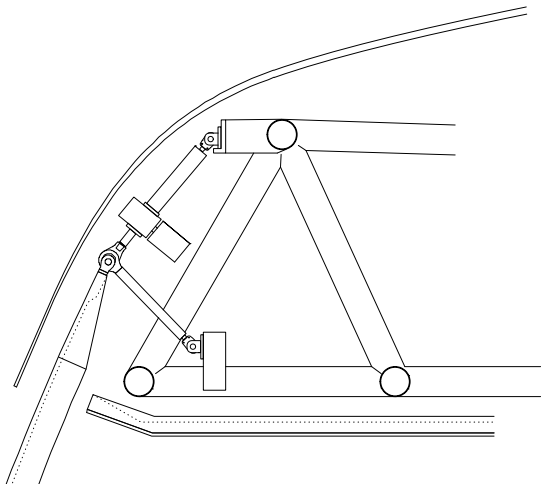

Section of top mounting showing drive and lamella anchorage

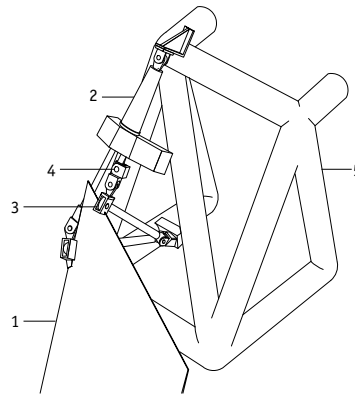

Axonometric projection showing drive, truss beam and lamella anchorage – 200 to 30 mm reinforcement at the vertical edges of the lamella

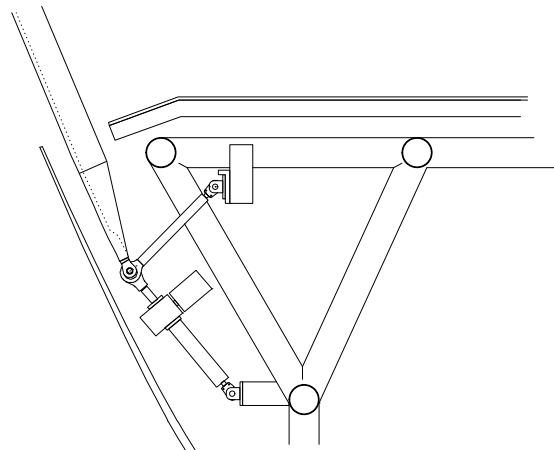

Section of bottom mounting showing drive and lamella anchorage

- 1 GFRP lamella, up to 13 m long, 10–20 mm thick
- 2 Synchronised servo motor 1FT/1FK, 2.29 kW
- 3 Ball screw spindle, flexibly mounted at both ends
- 4 Coupling member for lamella, swivel-mounted
- 5 Supporting structure, hollow steel profiles

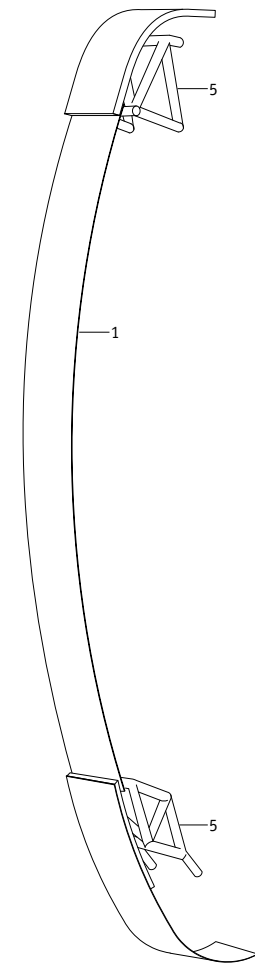

Axonometric projection of a single lamella



Simulation of the movement principle during concept development



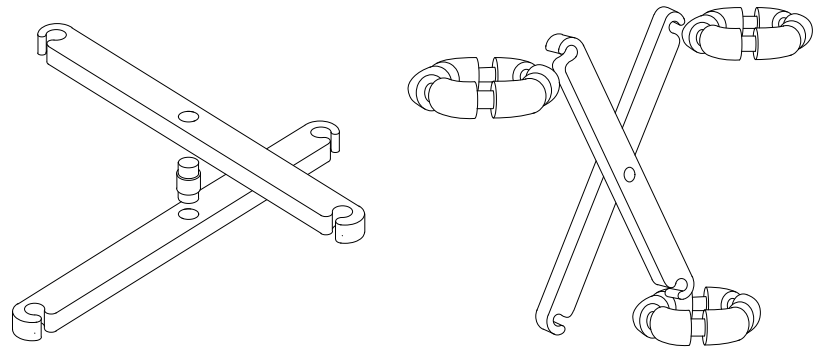

Axonometric projection of components and their assembly



## XXXX Sofa

Kyoto, Japan, 2011  
Yuya Ushida

The sofa was created for the Dutch company Ahrend by the designer Yuya Ushida, who designed and built the first prototype during his studies. At that time, he used bamboo as a building material. Ushida named the sofa “XXXX Sofa” after the flexible structure of its individual x-shaped elements. It consists exclusively of rods, rings and connecting pins, made using injection moulding. The individual components are simple, but when joined together

in a regular pattern, they form a complex geometric and movable structure.

The piece of furniture can be transformed by hand by two people pushing or pulling at its corners. As the construction is made of a single material and the plastic used is recyclable, no material separation is required to reuse the sofa as a raw material. In this sense, the life cycle of the system is effectively almost endless.

Other types of furniture such as chairs, tables and benches can also be manufactured according to the same principle. 8,000 rods in four lengths and 2,000 rings and pins are required for the sofa, whereas a chair consists of only 600 individual components.



Sofa collapsed and extended

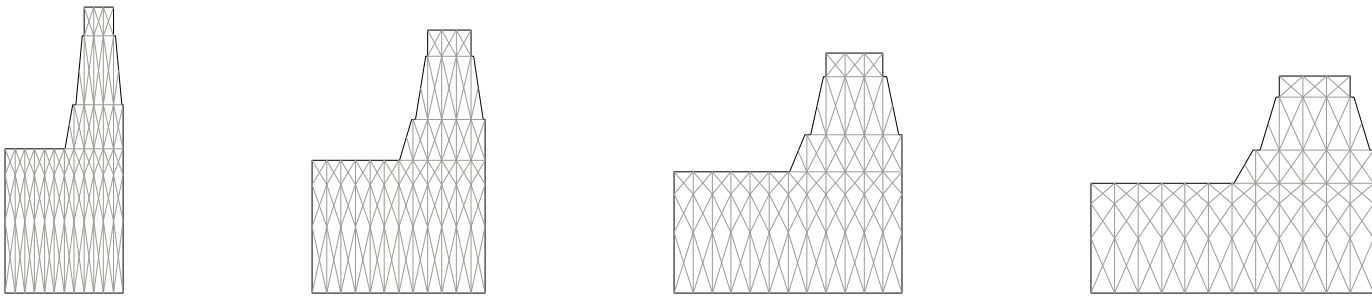

**Dimensions** Extended: L x H = 945 x 720 mm, collapsed: H x L = 943 x 391 mm **Number** 2,000 rings, 8,000 rods **Weight** 70 kg

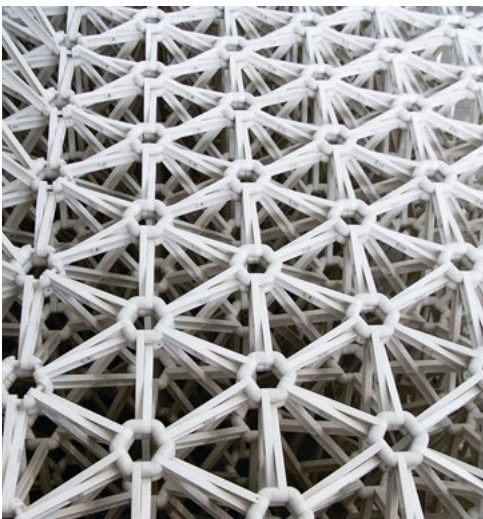

Construction detail – junction and connecting points

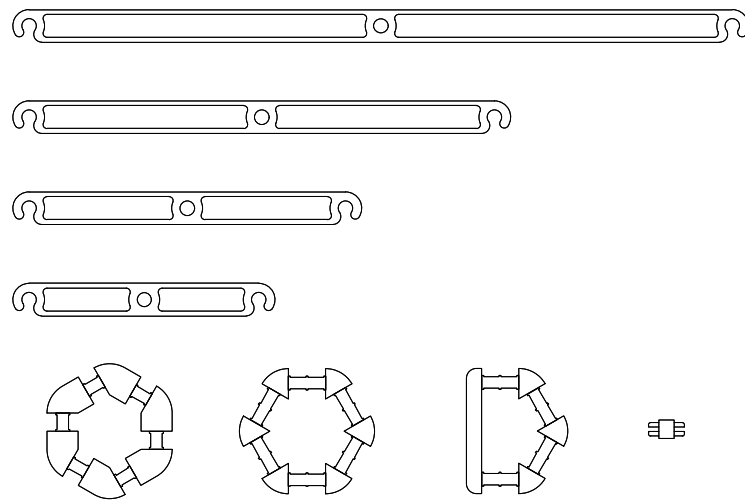

Elevation of the individual components in proportion to each other

1 Rods  
2 Rings

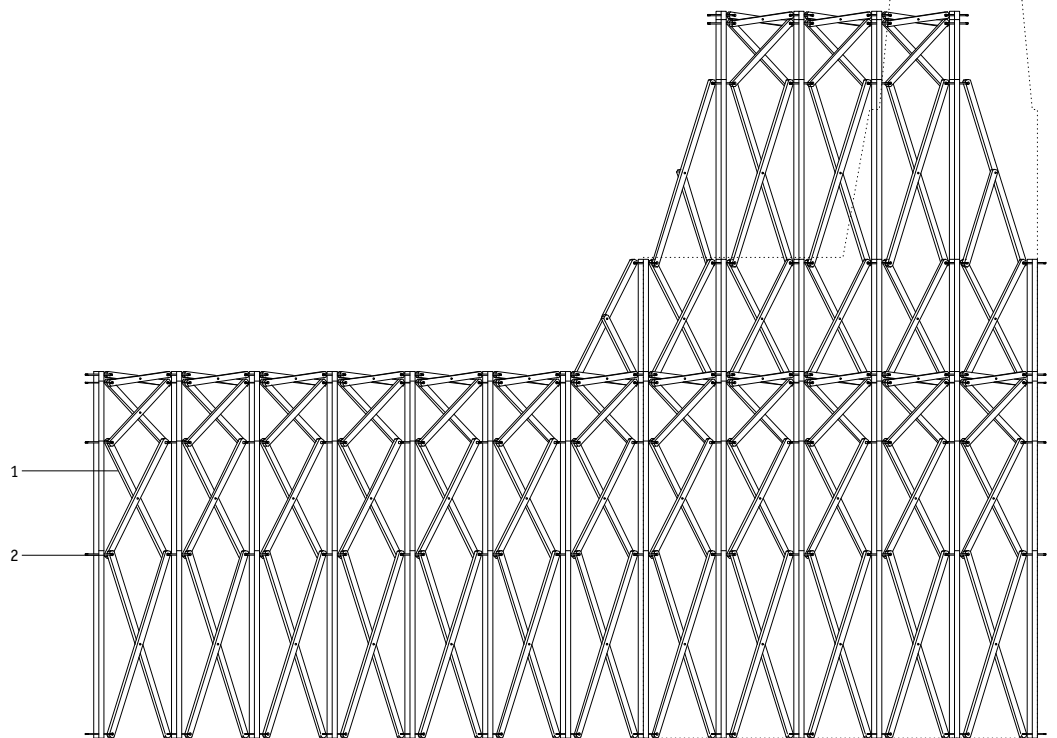

Elevation of the sofa when extended, 1:8



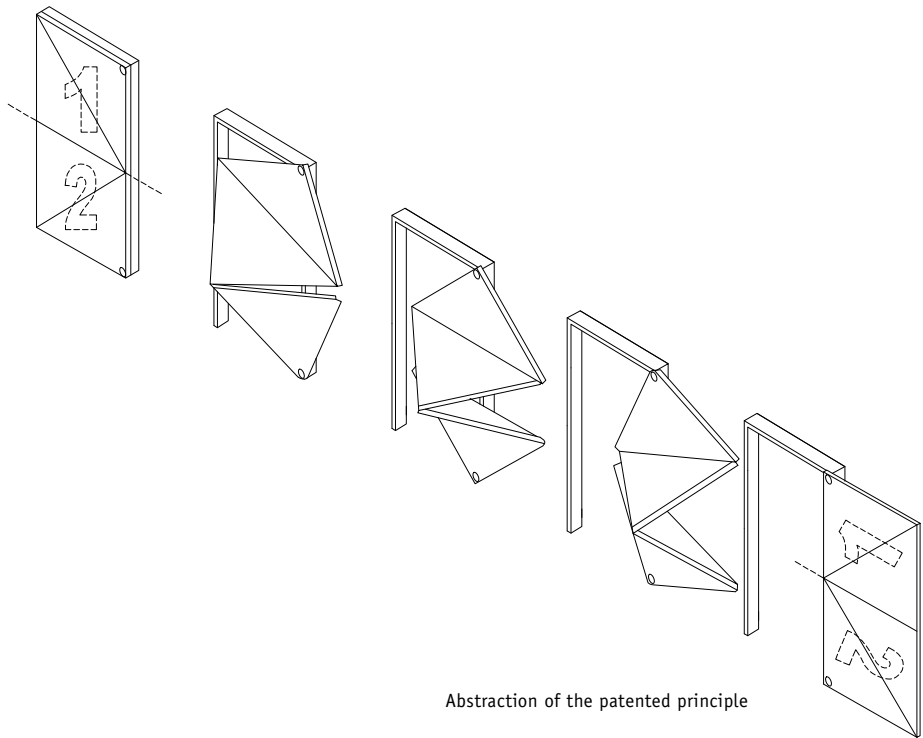

Abstraction of the patented principle



## EvolutionDoor

Vienna, Austria, 2013  
Klemens Torggler

EvolutionDoor is the name of a kinetic art object by Austrian artist Klemens Torggler, which, at the time of writing, was installed in the Kunstraum am Schauplatz gallery in Vienna. The project strove to look beyond usual door function methods and explore alternative opening mechanisms. It can be described in abstract terms as a device for closing an opening made of two parts that each rotate at their corners about an axis perpendicular to the axis of rotation.

The object measures 130 × 260 × 3.6 cm and weighs 100 kg, with the moving mass weighing 60 kg. The construction consists of a wooden frame covered

with MDF panels and steel fittings. To avoid trapping one's fingers, the edges are lined with a soft foam strip. The door's movement is initiated by hand and the speed of opening or closing depends on the user. Mathematically speaking, the EvolutionDoor is a spatial gear with a single degree of freedom. The movement mechanism is based on the function of a revolving plate door, and through successive revisions the artist was able to eliminate disadvantages, such as a leakage at the points where the panels join. The technical implementation requires only two concealed pivot points arranged vertically above one another, which allow the panels to move

freely, smoothly and noiselessly, while at the same time being very economical with space.

A twist-and-fold movement results in which two square surfaces fold into four triangular surfaces and at the same time move away from each other and then, as they continue to rotate, back towards each other. At first it appears as if the sculptural door collapses in on itself, the two triangles circling in opposite directions. But after apparently collapsing, the EvolutionDoor stretches back into its rectangular form, the collapsed quadrilaterals arranging themselves neatly back into a compact door panel.



Sequence of movement and rotation of the EvolutionDoor





## Fissured Living

Ahmedabad, India, 2018  
Matharoo Associates

Fissured Living is a home rooted in the notion of interdependent living. Designed for the families of two brothers and their aging parents, it accommodates three generations. The linear site is located in the neighbourhood of large wealthy homes on one side and a low-rise development on the other. The perimeter walls of the house are fissured to compensate for the short length of the open spaces

and invite nature in, as well as to break up the large building volume.

The double-height front door is composed of horizontal segments mounted on top of each other and pivoted on offset axes. The opening torque is evenly distributed to all segments via a cable drive mechanism, and the different rotation angles cause the elements to open and come to rest in varying

positions, making the door appear like a delicately balanced and dynamic kinetic sculpture.

The drive mechanism consists of 14 main bearings for movement and 28 rollers and counterweights for self-closing. Each segment measures 2,300 × 724 mm and weighs 230 kg and consists of a braced steel frame with a light sheet metal shell. The total weight of the door is 1,610 kg.

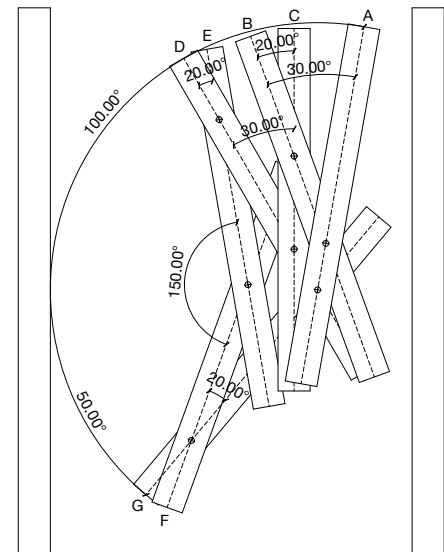

Top view of rotation positions and angles of door segments

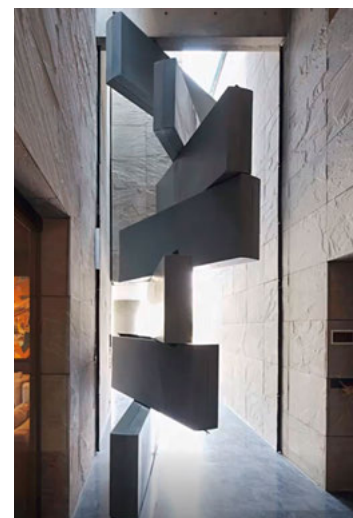
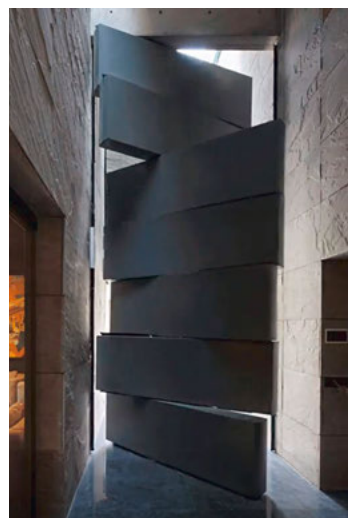

Opening sequence of the door segments

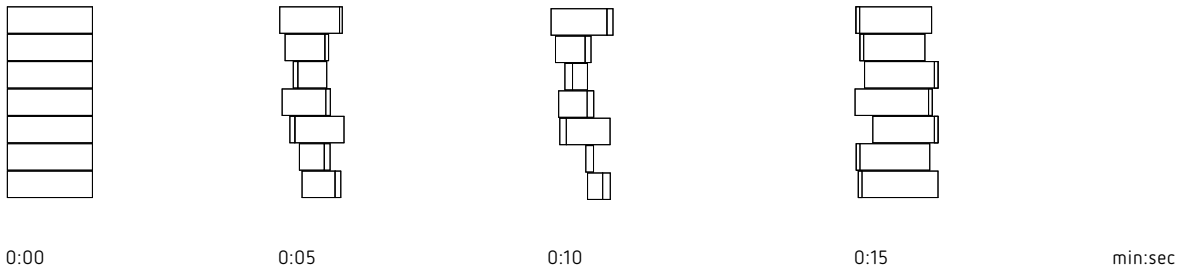

**Dimensions** Door opening:  $H \times W = 5.09 \times 2.30$  m, Door segments:  $L \times H \times W = 2.30 \times 0.70 \times 0.20$  m **Number 7** **Weight per element** 230 kg, total 1.6 t

- 1 Belt pulley,  $\varnothing 90$  mm
- 2 Core cut in lintel,  $\varnothing 150$  mm
- 3 Steel cable
- 4 Drilled hole
- 5 Anchor  $4 \times \varnothing 15$  mm
- 6 Steel plate  $\varnothing 180$  mm
- 7 Steel tube  $\varnothing 190$  mm, thickness 8 mm
- 8 Ball bearing
- 9 Roller  $\varnothing 18$  mm
- 10 Manual operation

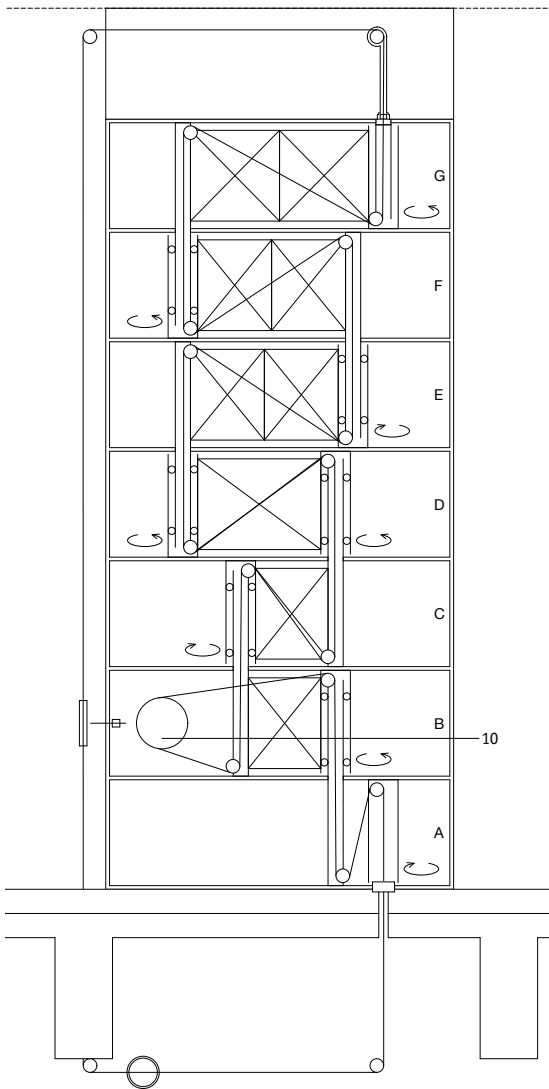

Elevation, 1:50

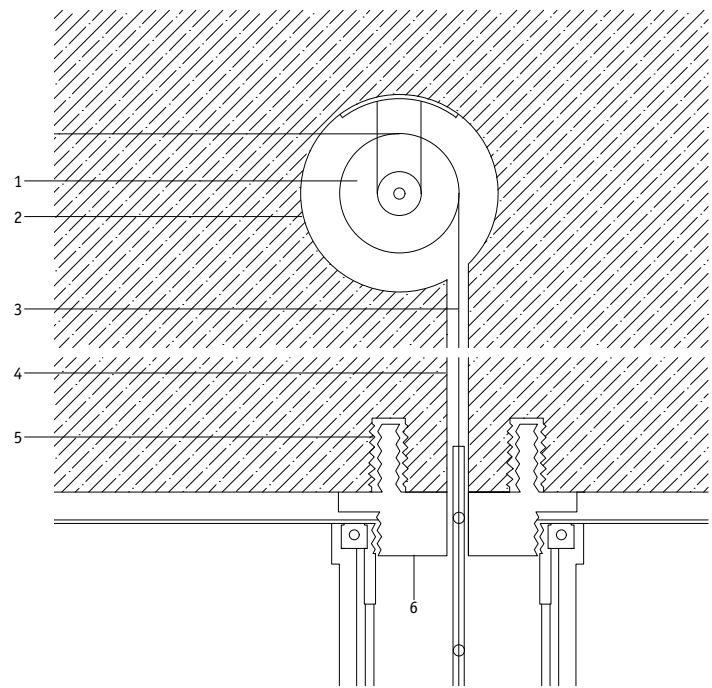

Detail, 1:10

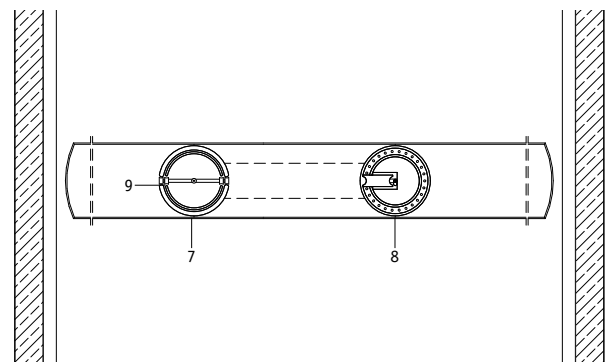

Horizontal section, 1:20

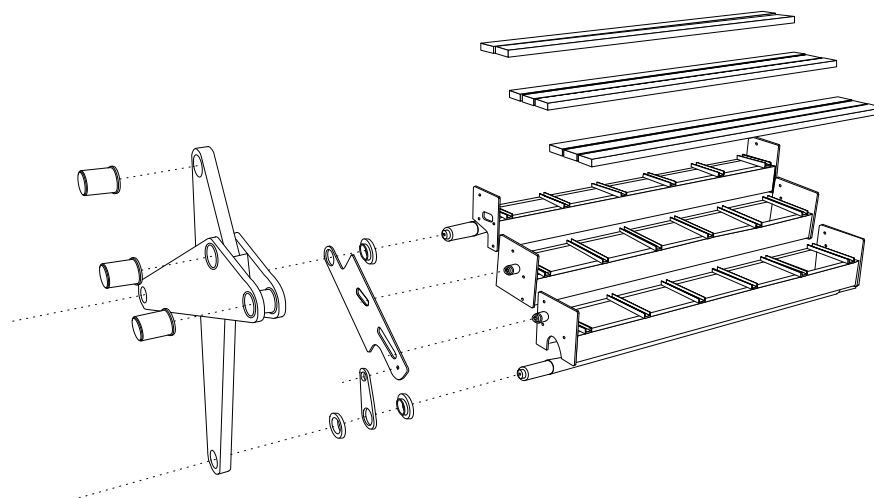

Exploded drawing of the horizontal and vertical components

## Scissor bridge at Jet d'Eau

Geneva, Switzerland, 2016  
Ingeni Ingenieure + MID Architecture

In 2013, an association for the promotion of mobility for people with disabilities initiated the project for an attractive means of barrier-free access to one of Geneva's most famous sights, the Jet d'Eau fountain. A 12 m long and 3,24 m wide bridge was built based on a scissor-pair mechanism.

Fifteen pairs of stainless steel scissors on each side of the bridge can compress to allow the bridge to lie flat so that wheelchair users can pass unobstructed, or expand to raise the bridge into an arch

beneath which boats can pass. In the raised position, the bridge has the form of a sinusoidal wave. As the bridge arches, the bridge deck transforms mechanically from a flat deck into a set of steps that allow pedestrians to cross while boats pass under the bridge.

The structural elements of the bridge are made of stainless steel and the bridge deck of oak. The mechanism comprises two basic parts: the stair stringer, which is linked to the corresponding scissor

by a rod to govern the slope of the stair; and the stair frame, which slides in the stair stringer to reach the desired position.

As the bridge transforms, the span increases and each scissor-pair rotates, causing the distribution of stresses to change. In the raised position, the scissors are under greater stress than in the horizontal position. The use of hydraulic cylinders in the structural system means that the structure is permanently active.



Bridge in raised and lowered positions





View of facade from the road



## The Bund Finance Centre

Shanghai, China, 2017

Heatherwick Studio and Foster + Partners

The building is located in Shanghai on the western bank of the Huangpu River opposite the Pudong Special Economic Zone. The Bund is the English name for the promenade, and gave the mixed-use building complex its name. As part of the renewal of the waterfront promenade as a connection between the old town and the new financial district, the complex marks the end point of Shanghai's most famous street. The challenge lay in achieving a connection of old and new architecture and mediating between the dimensions of the riverbank area and the historical quarters. The 4,000 m<sup>2</sup> building com-

plex is accessible to the public. The social focus of the programme is a cultural centre designed as a platform for international art and cultural exchange and as a venue for brand events and corporate functions.

The building appears to be surrounded by moving veils that adapt to the different areas of use and open to reveal the stage on the balcony as well as a view of Pudong. Its appearance is inspired by the traditional Chinese bridal veil. The facade was developed on site in collaboration with engineers from Tongji University.

It consists of three layers of 675 individual metal tubes or "tassels" made of a magnesium alloy, the shape of which is reminiscent of bamboo stems. The tubes run around the building on three rails, one behind the other. The length of the tubes ranges from about 2 m to 16 m, so that the veil ripples in a wave-like fashion around the building with every movement. The constantly changing overlap of the three veils produces visual effects of differing "opacity".

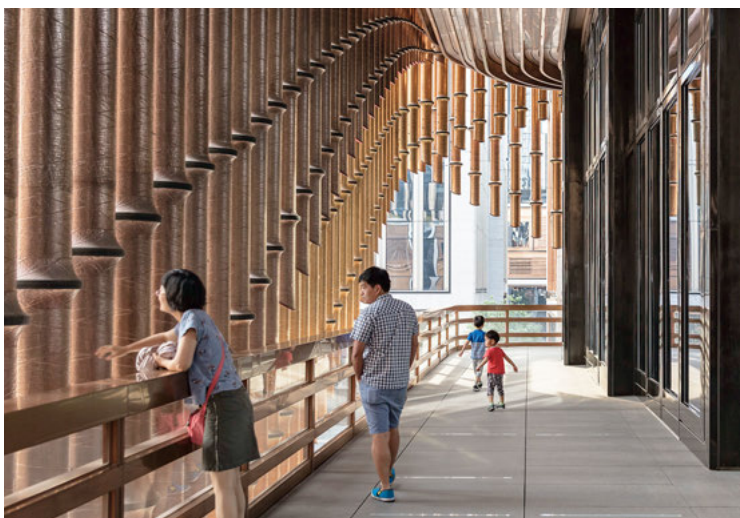

View of facade veil from walkway

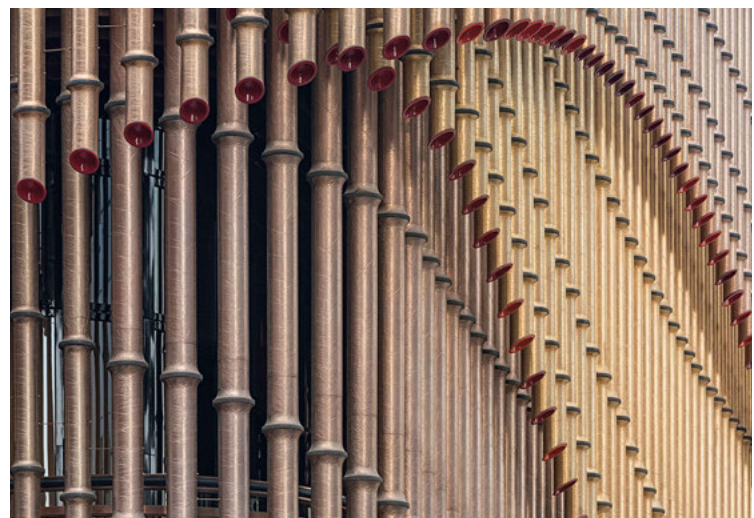

Facade veils of metal tubes surrounding a perimeter balcony

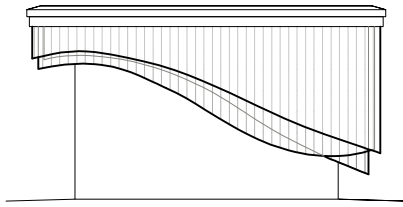

0:00

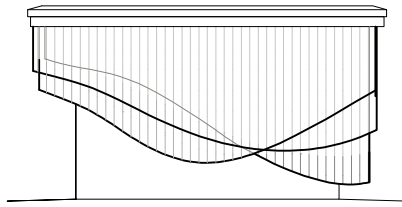

0:12

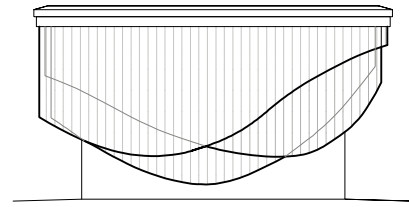

0:24

min:sec

Dimensions L = 2-16 m Number 675

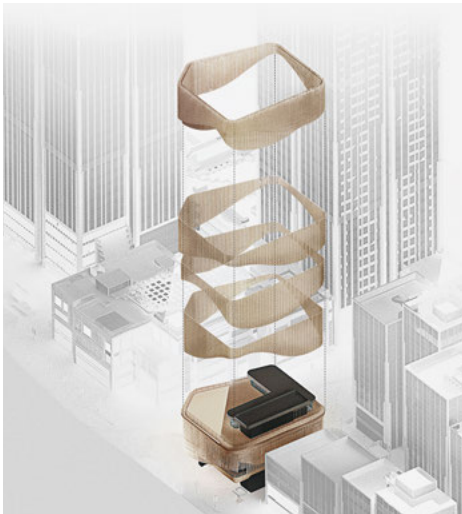

Exploded drawing of building skin and layered veils

- 1 Stone panel cladding
- 2 Cladding, coloured stainless steel sheet, 2 mm
- 3 Hanging fixture and guide rails
- 4 Mounting brackets, L-profile, stabilisation rail
- 5 "Bamboo" tubes, coloured stainless steel with bamboo moulding, Ø 300 mm
- 6 Facade veil and walkway

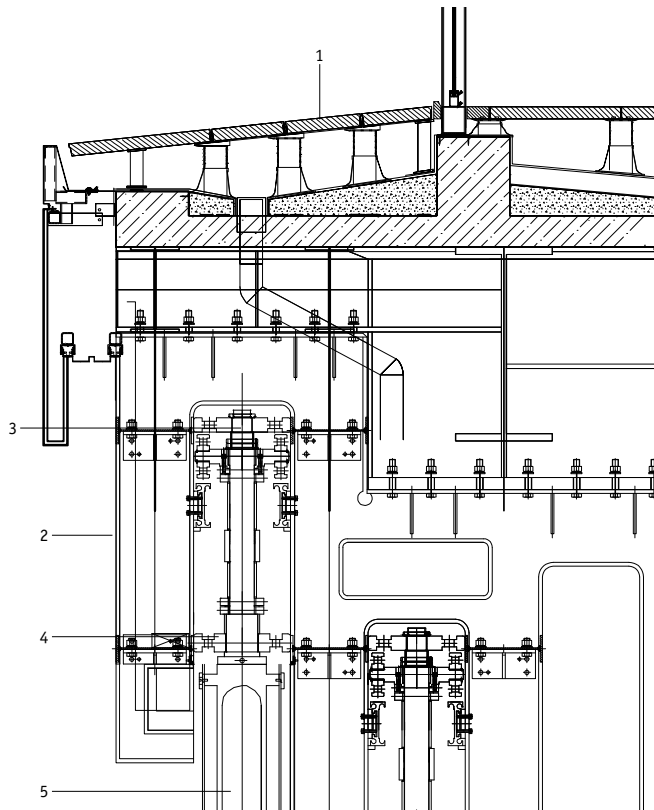

Detail section of top junction, 1:33

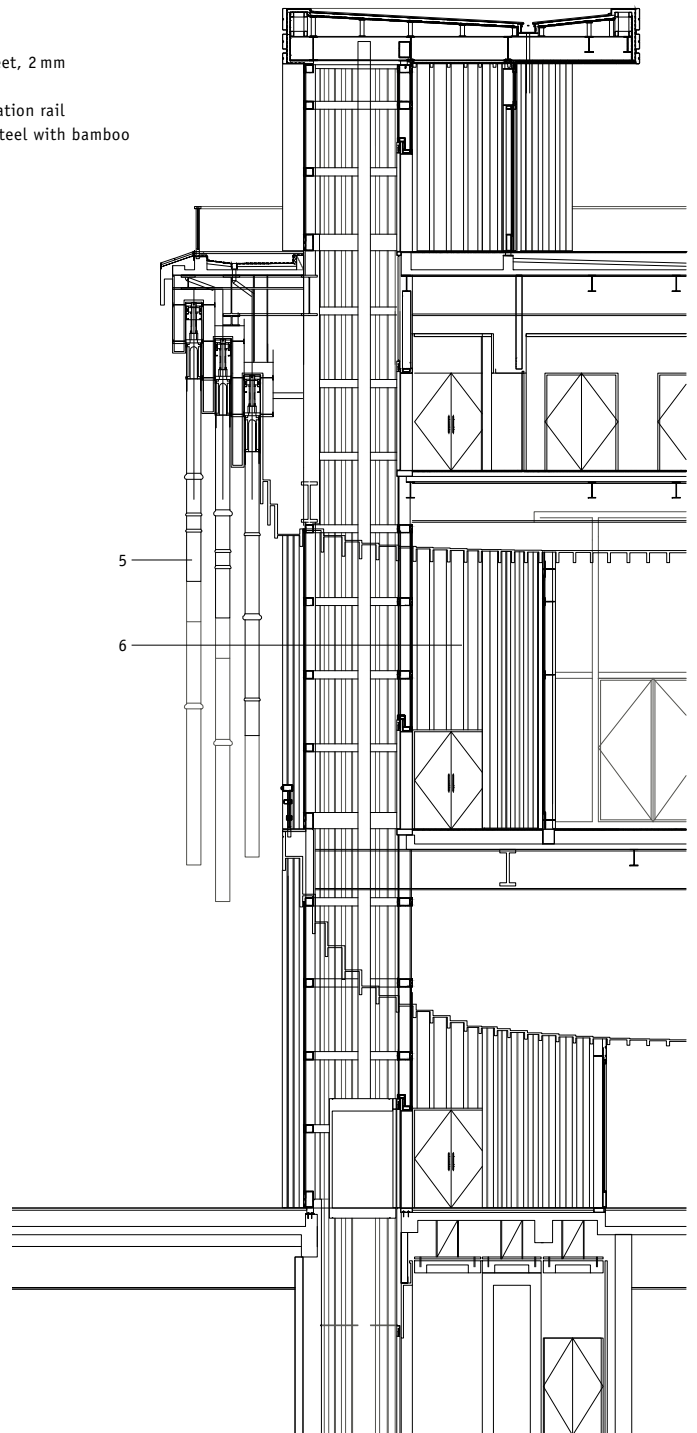

Section through facade, 1:200

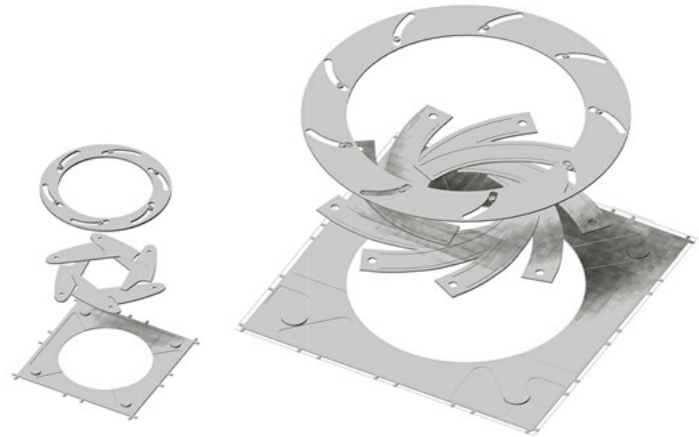

Exploded drawing with two lenses – abstraction of the “mashrabiya”



## Institut du Monde Arabe

Paris, France, 1987

Jean Nouvel, Gilbert Lézénès, Pierre Soria,  
Architecture Studio

The Institut du Monde Arabe sees itself as a showcase for the Arab world in Paris. Completed in 1987, the building was designed by architect Jean Nouvel, Gilbert Lézénès, Pierre Soria and Architecture Studio, a joint initiative by France and several Arab countries. The result is not an Arabic building, but a western building with certain symbolic elements such as the mashrabiya, which refer to Arab tradition. The “moucharabieh”, as they are called in

French, are composed of polygons of different shapes and sizes and create and make reference to the geometric art of Arab cultures.

The south wall consists exclusively of a screen of camera-like diaphragms. In low light levels, the diaphragm mechanisms twist open, by means of a photoelectric cell on the roof, closing again in the opposite direction as the sun begins to shine more brightly. The expanding and contracting mechanism

of these lens-like apertures is regulated by sliders so that the building automatically controls the amount of light entering the interior. At the same time, the varying degree of transparency and closure creates constantly changing geometric shadow patterns in the interior that recall the decor of Arab buildings.

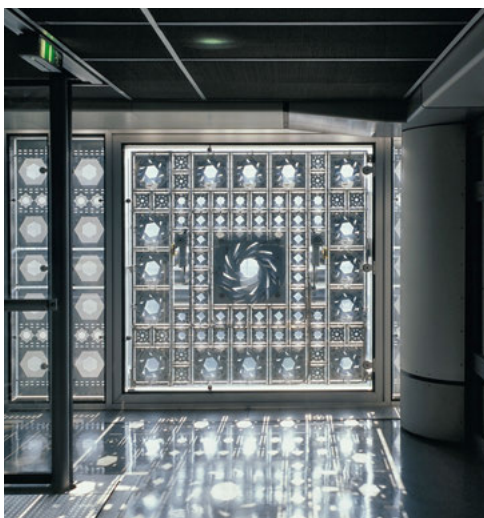

Interior view of “mashrabiya”

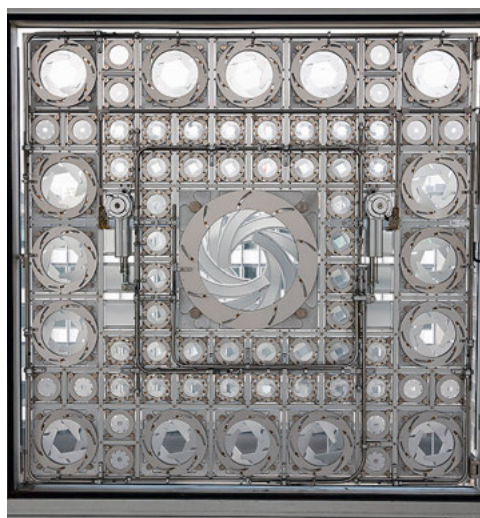

An entire facade board – a “mashrabiya” module

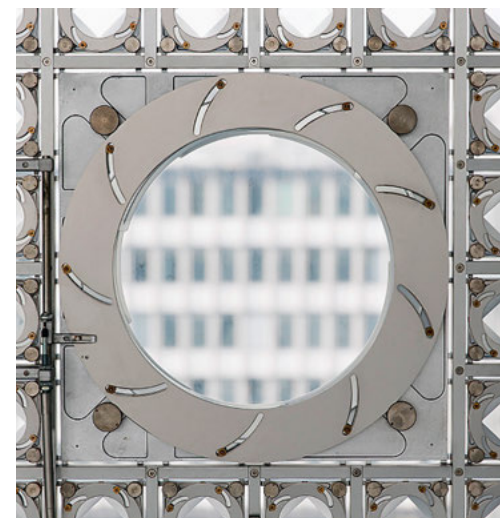

Large iris in open state

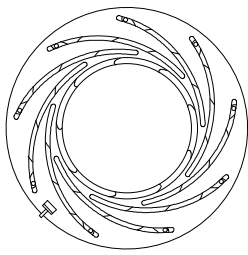

0:00

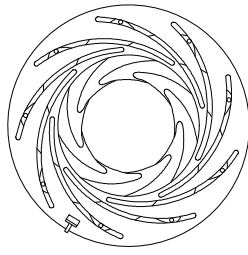

0:01

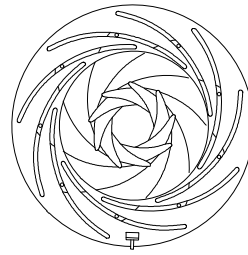

0:02

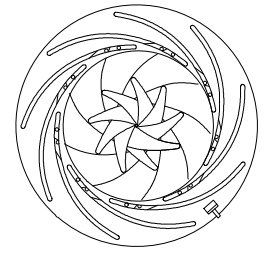

0:03

min:sec

**Dimensions** Large iris L x W = 564 x 564 cm, inner module panel L x H = 2.10 x 2.10 m, outer frame 2.90 x 2.90 m

**Number** 240 module panels on the south facade, each with 73 iris elements

- 1 Star-shaped iris, 150 x 150 mm
- 2 Square iris, 150 x 150 mm
- 3 Aluminium frame, 18 x 25 mm
- 4 Slide control
- 5 Slide control
- 6 Push-pull cable, traction 540N, compression 315 N, 666 mm long, travel 76 mm
- 7 Screw, M6x16
- 8 Motor

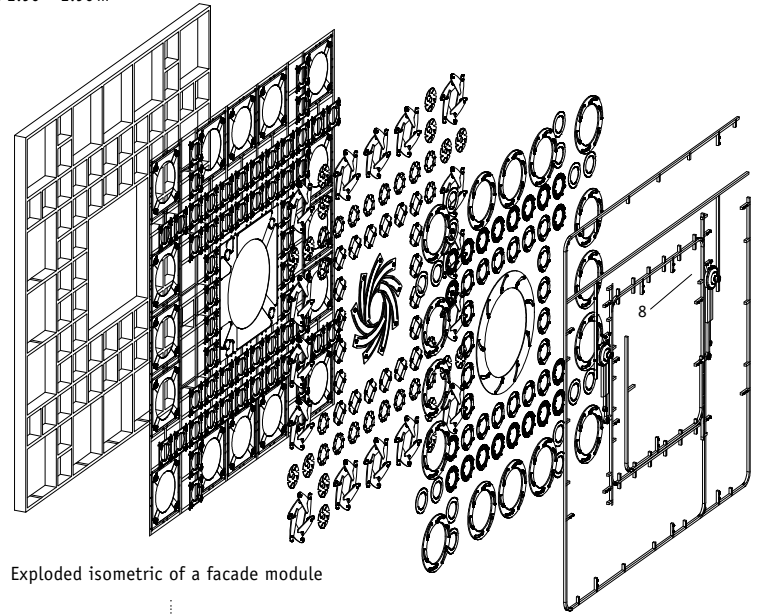

Exploded isometric of a facade module

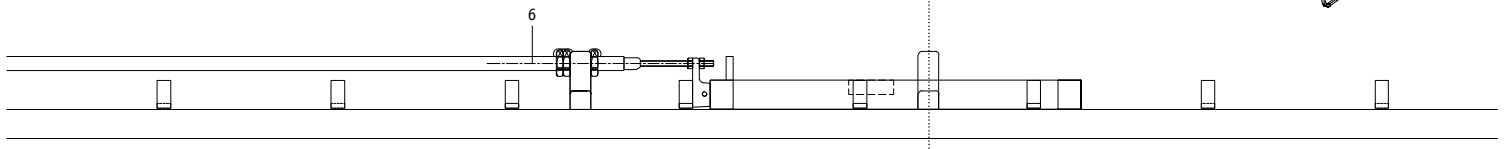

Section, 1:65

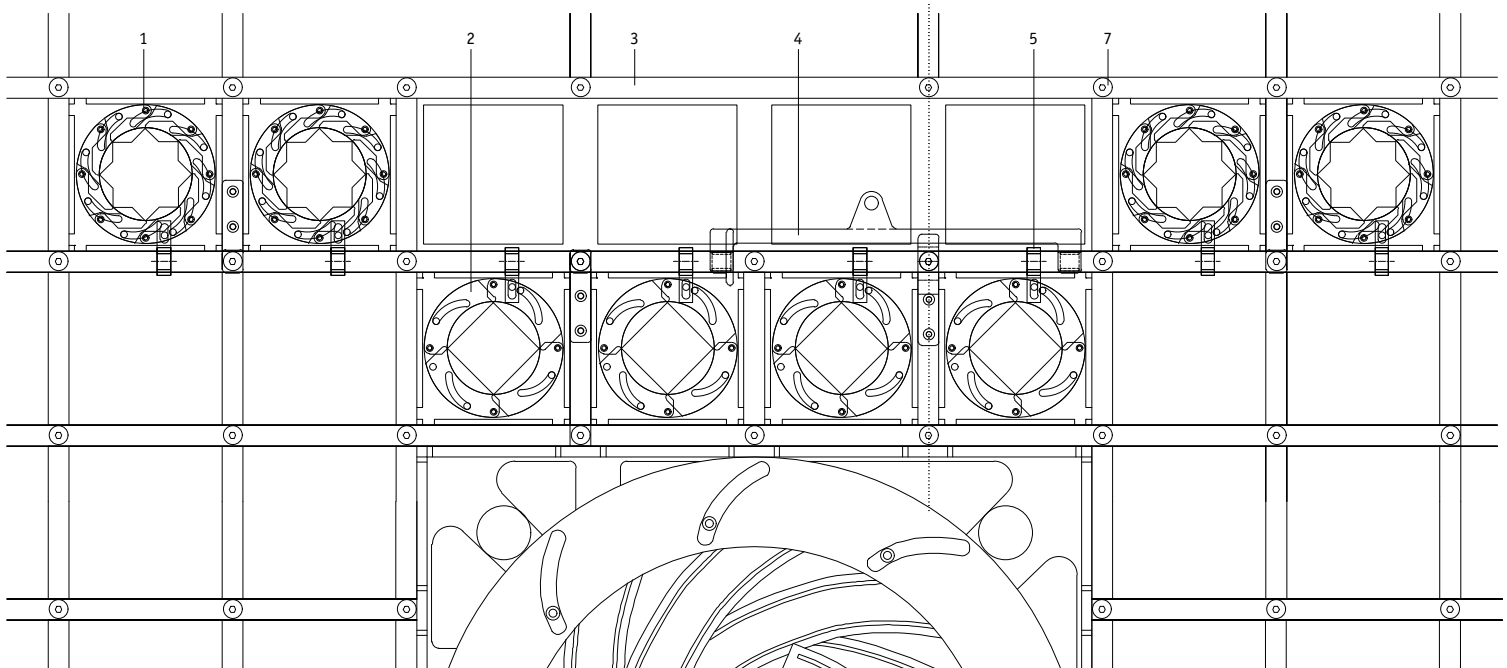

Elevation, 1:65

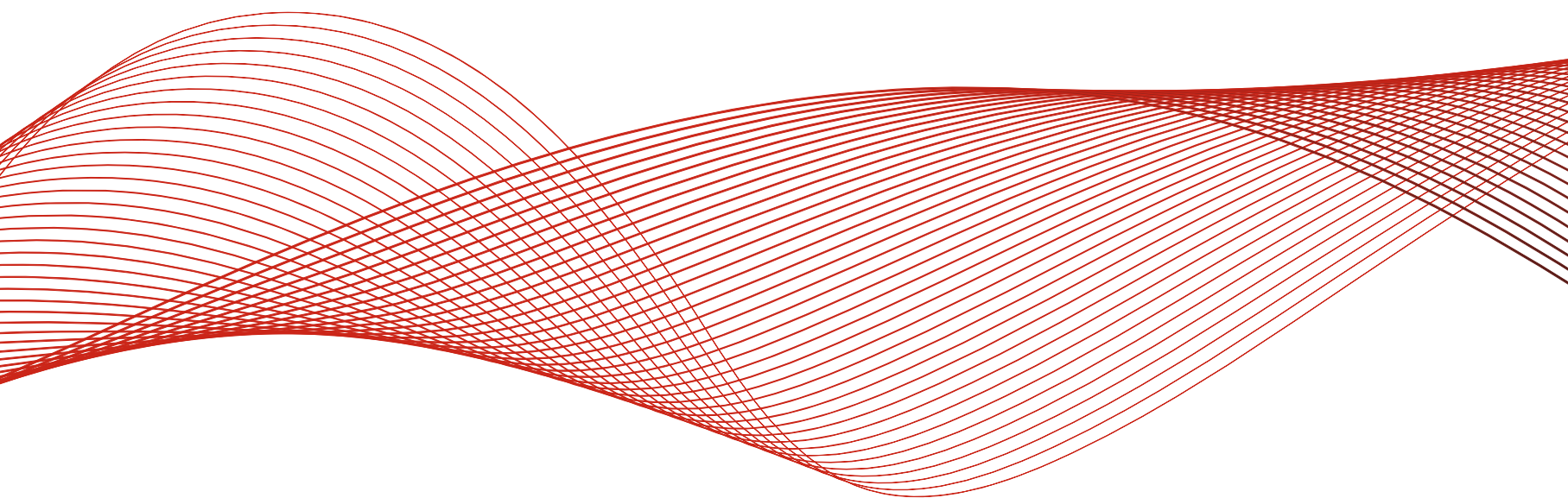

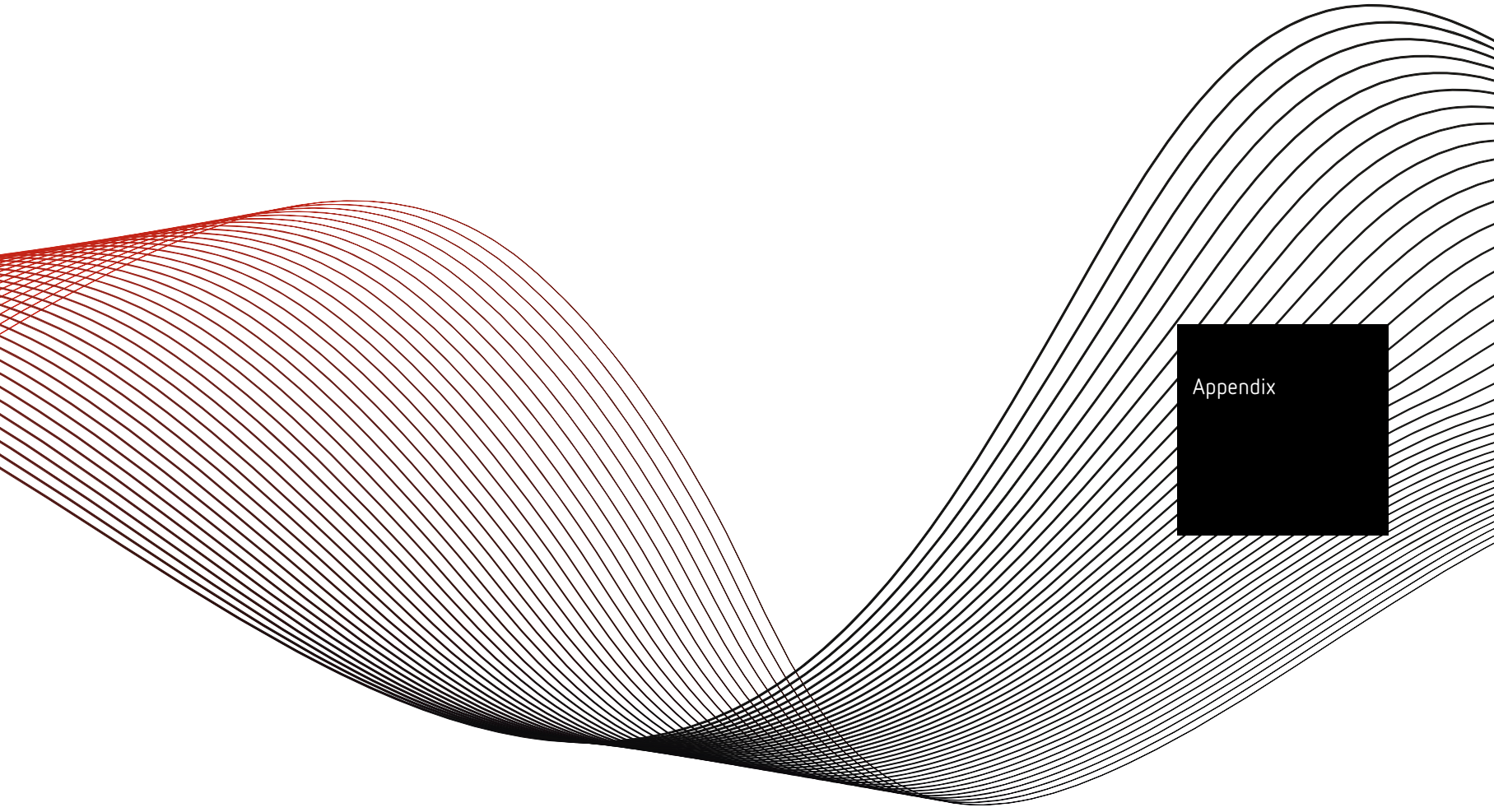

Appendix

## About the authors and contributors

**Prof. Michael Schumacher**, born in 1957, studied at TU Kaiserslautern from 1978 to 1985 and subsequently completed postgraduate studies at the Städelschule Frankfurt/Main with Peter Cook. In 1987 he worked as a freelancer for Sir Norman Foster in London and for Braun und Schlockermann in Frankfurt/Main. Together with Till Schneider, he founded schneider+schumacher in 1988. From 1999 to 2000 he was guest professor at the Städelschule in Frankfurt/Main, and in 2002 supervisor for the scholarship holders at Designlabor Bremerhaven. In 2004 he was appointed chairman of the BDA Association of German Architects for the State of Hessen. Since 2007 he has been professor and head of the Department of Building Construction and Design at the Institute of Design and Construction, Leibniz University Hannover. In 2008 he founded the MOVE research group with Oliver Schaeffer and Michael-Marcus Vogt, with whom he published *MOVE – Architecture in Motion – Dynamic Components and Elements* in 2010. He is a member of the urban planning advisory board for Frankfurt/Main and a member of the AIV Association of Architects and Engineers.

**Michael-Marcus Vogt**, born in 1972, studied from 1991 to 1997 at Leibniz University Hannover under Prof. Peter Schweger and others. His diploma, supervised by Prof. Peter Kaup, was awarded the Laves Prize of the Lower Saxony Chamber of Architects. He then worked as a freelancer in the architecture firm Venneberg & Zech Architekten BDA and in the engineering company Prof. Michael Lange on design and

implementation planning. In 2000 he returned to Leibniz University Hannover as a research assistant, first with Prof. Kaup, later with Prof. Michael Schumacher at the Department of Building Construction and Design. He is a founding member of the MOVE research group established at this department in 2008 and undertakes research, among other things, into dynamic materials and application technologies for adaptive facade systems. In cooperation with Dettmer Architekten BDA, he works on his own residential, commercial and industrial building projects. Since 2018 he assists gruppeomp Architekten-gesellschaft mbH BDA in their quality assurance procedures.

**Luis Arturo Cordón Krumme**, born in 1989, studied at Leibniz University Hannover and Università degli Studi Roma Tre in Rome from 2008 to 2015. Together with Anna Bauer, he received the Laves Prize of the Lower Saxony Chamber of Architects in 2012. His Master's thesis, completed in 2015 under Prof. Michael Schumacher and Prof. Zvonko Turkali, was awarded a special distinction by the dean Prof. Jörg Friedrich and won the Laves Prize a second time in 2015. In the same year, he joined schneider+schumacher in Frankfurt/Main, where he develops projects on the reconstruction and reuse of existing buildings and studies of housing projects with a focus on construction, cost efficiency and appropriate use of materials. He joined the Department of Building Construction and Design, Leibniz University Hannover, as a research assistant and teacher in 2015, where he works among other things on

architectural projects in Latin America. His research focus is the identity of Latin American architecture and its manifestation in design and construction. In 2016 he became a member of the MOVE research group at the Department of Building Construction and Design, where he deals with new dynamic materials and moving elements in architecture.

This book was conceived and produced at the Institute of Design and Construction, Department of Building Construction and Design, Leibniz University Hannover. The authors would particularly like to thank all the students who contributed to this publication:

Nikola Biševac, Eduard Mica, Jascha Baumgardt, Paul Eichholtz, Neele Lemke, Larissa Theil, Vanessa Niemeyer, Kim Flottmann, Fabian Wiczorek, Alexander Frisch, Jonas König.

**Christina Chalupsky**, born in 1986, studied architecture at TU Wien under Prof. William Alsop and others, as well as at TU Berlin. After various internships in architectural offices in Linz, Vienna and London, she graduated in 2013 under Prof. András Pálffy. From 2014 to 2018 she worked for schneider+schumacher. Parallel to her planning practice, she was a guest art student at HfG Offenbach University of Art and Design from 2016 to 2018, specialising in experimental spatial concepts. She has worked as a freelance architect in Frankfurt/Main since 2018 and is especially interested in the interface between architecture, design and art.

**Max Schwitalla**, born in 1980, studied architecture at the University of Stuttgart and ETH Zurich from 2000 to 2006, graduating with a diploma/MSc ETH in architecture. From 2004 to 2005 he worked for Rem Koolhaas/OMA in Rotterdam and New York, and from 2007 to 2011 as a freelance architect for GRAFT in Los Angeles and Berlin and for HENN in Berlin. As a design architect he was responsible, among other things, for major projects in China. In 2012 he founded Studio Schwitalla in Berlin with a focus on design and research for future urban mobility and urban development. He has undertaken cooperative projects with research partners and mobility experts such as Schindler in Ebikon, Audi in Ingolstadt, e.GO Mobile in Aachen and the Fraunhofer IA0/CeRRI in Berlin. His other activities include lectures in Germany and abroad, workshops, publications and the development of dome films.

**Klaudia Kruse**, born in 1960, studied product and industrial design at the FH Aachen and HFBK Hamburg. After working in industrial and fashion design, she worked for BMW in Advanced Design from 1990 to 2009. Her tasks included projects such as the GINA Concept Car and the conception and studio management of the BMW Group Design Think Tank in New York. Since 2010 she has been a freelance international design consultant with a studio in Mu-

nich. She develops design strategies and concepts with a focus on research, colour, material and surface design in the fields of architecture and automotive, product, fashion and furniture design. Klaudia Kruse also teaches at the UDK Berlin, the University of Kassel and other schools, as well as giving lectures and running workshops.

**Dr.-Ing. Carsten Schmidt**, born in 1975, studied electrical engineering at Leibniz University Hannover and received his doctorate in mechanical engineering under Prof. Dr.-Ing. Berend Denkena at the Institute of Production Engineering and Machine Tools. From 2009 to 2011 he coordinated research and development projects in the field of aviation involving science and industry. Parallel to this, he also worked as a management consultant for ProWerk GmbH and advised in the area of target cost management. Since 2011 he has been director of the inter-university research centre for the high-performance production of CFRP structures (HP CFRP) of Leibniz University Hannover, TU Braunschweig and Clausthal University of Technology at the CFK Nord Research Centre, where he is responsible for interdisciplinary research and development projects in the field of fibre-composite technologies.

**Dr. Shankar Kumar Jha**, born in 1983, received his doctorate in 2014 from the Department of Materials at the ETH Zurich. From 2015 to 2018 he headed the research and development department of MDT-tex, a company that develops and manufactures multifunctional membrane structures for architecture. This also includes the development of “intelligent” textiles and membranes that improve the aesthetic and functional properties of the overall structure.

**Sara Nester**, born in 1997, has been studying textile technology and textile management at Reutlingen University since 2015. In 2017/18, she completed a six-month practical semester at MDT-tex in the field of membrane construction and textile ar-

chitecture. Since March 2019, she has been working on her Bachelor's thesis on “Functionalisation of basic textile structures”.

**Prof. Dr.-Ing. Jan Knippers**, born in 1962, studied civil engineering at TU Berlin and received his doctorate in 1992. He then worked for several years in an internationally renowned engineering office before being appointed head of the Institute of Building Structures and Structural Design (ITKE) at the University of Stuttgart in 2000. In 2001 he founded Knippers Helbig Advanced Engineering and 2018 Jan Knippers Ingenieure in Stuttgart. In teaching, research and practice, he works on computer-based planning and manufacturing processes as well as fibre-based materials and bionics for resource-efficient structures in architecture.

**Axel Körner**, born in 1981, studied architecture at Munich University of Applied Sciences and Emergent Technologies and Design at the Architectural Association School of Architecture in London. Between 2008 and 2014 he worked for various architectural firms in Munich, Vienna and London and taught at the AA School of Architecture. Since 2014 he has been a research fellow at the Institute of Building Structures and Structural Design (ITKE) at the University of Stuttgart, where he conducts research into bio-inspired mechanisms based on elastic deformation. He also teaches in the international Master's Programme Integrative Technologies and Architectural Design Research (ITECH) at the University of Stuttgart.

**Dr.-Ing. Laura Kienbaum**, born in 1981, is an architect, journalist and freelance curator. She works at the intersection of theory and practice with special focus on the production of spatial experiences and research into architectural design features, and design and communication methods. As Creative Director at combine design, co-founder of the architecture and research network SUPA (Sam and Plank-

ton Architecture), research assistant at Leibniz University Hannover and as co-curator at the German Architecture Museum in Frankfurt/Main, her portfolio ranges from scenographic installations to professional articles, publications and exhibitions in Germany and abroad.

**Marvin Bratke**, born in 1985, is an architect and designer and founding partner of the interdisciplinary design studio BART//BRATKE. Founded as a network for exchanges between creative designers, after ten years of cooperation on research projects in university and other contexts, the studio developed into a knowledge platform with a focus on the development of adaptable and flexible architectural systems. Marvin Bratke holds guest professorships at Muthesius University of Fine Arts and Design in Kiel and at the Universidad Internacional SEK in Quito. He graduated from Technical University of Munich and Nanyang Technological University (NTU) in Singapore. His research and design work focuses on the development of novel technologies at the intersection of architecture, industrial design and mobility. He has worked together with numerous international architectural firms including GRAFT, LAVA and Kéré Architecture.

**Paul Clemens Bart**, born in 1986, architect and designer and founding partner of the interdisciplinary design studio BART//BRATKE, works and researches at the intersection of architecture, interactive design and mobility. He studied at the École Spéciale d'Architecture Paris, NTU Singapore and Technical University of Munich, where he graduated as an engineer. He also holds a Master of Architecture degree from the Design Research Lab of the Architectural Association School of Architecture in London. His work focusses on new technologies, digital methodologies and their application in adaptive architectural systems at all scales. His research and design contributions have been published and exhibited internationally, including at the 13th Architecture Biennale in Venice, the Nesta

FutureFest London and the IAA Frankfurt. Paul Clemens Bart is a visiting professor at Universidad Internacional SEK in Quito and also teaches at the UCL Bartlett School of Architecture in London and the Cooper Union School in New York. Previously he worked with Zaha Hadid Architects in London, LAVA in Sydney and Berlin and the German Institute of Science and Technology in Singapore.

**Prof. Mirco Becker**, born in 1975, studied first in Kassel and then from 2001 to 2003 at the AA School of Architecture in London. Since then he has had a particular interest in computational design, working for Zaha Hadid Architects, the Specialist Modelling Group (SMG) at Foster + Partners and the Kohn Pedersen Fox Computational Geometry Group, which he managed for five years as Senior Associate Principal and with whom he was responsible for the digital planning of the 600,000 m<sup>2</sup> Abu Dhabi Airport Midfield Terminal. He taught at the AA School, was Chair of Digital Design as a visiting professor at the University of Kassel from 2006 to 2008 and held the endowed Chair of Architecture and Performative Design at the Städelschule in Frankfurt/Main from 2012 to 2016. In 2016 he was appointed Professor for Digital Methods in Architecture (dMA), Institute for Art and Technology at Leibniz University Hannover.

**Prof. Dr.-Ing. Arndt Goldack**, born in 1969, studied civil engineering at the University of Stuttgart from 1992 to 1996. He then worked until 2003 as a teaching and research assistant at the Chair for Construction and Design at the University of Stuttgart under the direction of Prof. Jörg Schlaich (later the Institute for Lightweight Structures and Conceptual Design under the direction of Prof. Werner Sobek). He received his doctorate in 2004 from the Faculty of Civil Engineering at the University of Stuttgart. From 2004 to 2011 he was a structural engineer and project manager at schlaich bergemann partner in Stuttgart and Berlin. There he worked on various national and international projects. His areas of ex-

pertise include the vibration behaviour of pedestrian bridges, the measurement of vibrations and system identification. He is co-author of the HiVoss guidelines (guidelines and explanations for the design of pedestrian bridges and floor slabs subject to vibrations). In 2011, he moved to the Chair of Conceptual and Structural Design under the direction of Prof. Mike Schlaich at TU Berlin, where he conducted research in the field of pedestrian-induced vibrations and active vibration control. In April 2018 he was appointed Professor for Statics and Dynamics of Structures at Bergische University of Wuppertal.

**Prof. Dr. sc. tech. Mike Schlaich**, born in 1960, studied at ETH Zurich where he also received his doctorate. Since 1999 he has been managing director of schlaich bergemann partner, and since 2004 professor at the Chair of Conceptual and Structural Design at TU Berlin. He is also a test engineer for structural analysis. His current research and teaching at TU Berlin focuses on light, active and mobile structures in the building industry. As managing director of schlaich bergemann partner, he has designed projects all over the world. He has won numerous national and international awards in recent years as part of his collaboration with renowned architects. All his projects reflect his conviction that building technology should always strive to be elegant. As a specialist in lightweight construction, he is an advocate of a holistic design approach that affords engineers greater responsibility and a stronger role in contributing to building culture.

**Jonas Kleuderlein**, born in 1978, studied civil engineering in Dresden and completed his diploma thesis under Prof. Dr.-Ing. Bernhard Weller. From 2007 to 2016 he supervised several major projects for Bilfinger SE. He has been with SGS GmbH – Schütz Goldschmidt Schneider in Heusenstamm since 2016, where he is responsible for facade consulting. From 2010 to 2014 he was a research assistant with Prof. Dr.-Ing. Jens Schneider in Darmstadt. He teaches facade engineering at Bergische

University of Wuppertal, MBE Baubetrieb, and at Augsburg University of Applied Sciences.

**Sara Kukovec**, born in 1988, studied civil engineering and management at the University of Maribor and the University of Stuttgart. In 2015 she graduated from Frankfurt University of Applied Sciences and RheinMain University of Applied Sciences with a Master of Engineering in Structural Engineering and Construction Management. From 2013 to 2016 she worked as a project engineer for Bilfinger SE and later until 2019 as a project manager for SGS GmbH – Schütz Goldschmidt Schneider. She currently manages projects at the Ten Brinke Group. In addition to her work as a project manager, her focus during and since her studies has been on research projects in the field of facade technology and smart materials.

**Prof. Dr.-Ing. Annika Raatz**, born in 1971, studied mechanical engineering at TU Braunschweig, receiving her doctorate on the subject of material-locking joints made of pseudo-elastic shape memory alloys in parallel robots. Since 2013 she has headed the Institute of Assembly Technology at Leibniz University Hannover. Her research focuses on robot-assisted assembly, in particular the development and modelling of machine concepts and components as well as the design of automated assembly processes.

**Mats Wiese**, born in 1989, studied mechanical engineering at TU Braunschweig and Leibniz University Hannover. Since 2017 he has been a research assistant at the Institute of Assembly Technology at Leibniz University Hannover. His work focuses on structural-mechanical modelling and simulation of soft robots as well as hybrid modelling with machine learning.

**Olaf Schroeder**, born in 1966, studied product design at HfG Offenbach University of Art and Design from 1986 to 1995, under Prof. Lore Kramer, Prof. Dieter Mankau and Prof. Richard Fischer, among others. Since 1996 he has developed design concepts

and solutions for furniture and interior design. His works are based on conceptually puristic considerations and give special focus to the construction of a product or system. Between 1998 and 2002 he was a lecturer at HfG Offenbach and from 2004 to 2008 he was a regular guest lecturer and workshop tutor for “Furniture and environmental design” at the Department of Industrial Design of Tunghai University of Taichung, Taiwan. His work has won numerous design awards, including the German Design Award in 2016 and 2017.

**Prof. Dr.-Ing. Dr.-Ing. E. h. Dr. h. c. Werner Sobek**, born in 1953, studied architecture and civil engineering at the University of Stuttgart. He was appointed to the University of Hannover in 1991 and to the University of Stuttgart in 1994. There he heads the Institute for Lightweight Structures and Conceptual Design (ILEK) and teaches as a visiting professor at numerous universities in Germany and abroad. Since 2017 he has represented the Collaborative Research Center SFB 1244 “Adaptive Envelopes and Structures for the Built Environment of Tomorrow”. He is founder of the Werner Sobek Group, a global network of planning offices for architecture, structural design, facade planning, sustainability consulting and design, and is also the founder and president of several non-profit initiatives such as aed e.V.

**Kaja Schelker**, born in 1983, studied architecture at the University of Stuttgart and the University of Porto from 2003 to 2009, graduating with a diploma. She then worked in the Swiss canton of Grisons as an architect with Jüngling und Hagmann Architekten and with Men Duri Arquint Architekt as a construction and project manager. While working, she attended the postgraduate cultural studies course at the University of Warsaw. In 2014 she became a member of the Bavarian Chamber of Architects. She has been a research assistant with Prof. Werner Sobek at the Institute for Lightweight Structures and Conceptual Design at the University of Stuttgart

since 2013. Since 2017 she has also been a doctoral candidate in art history at Ludwig-Maximilians-Universität in Munich. She is currently undertaking her doctorate under Prof. Burcu Dogramaci on the topic of regional building by the architect Anna Górska in the time of Stalinism in Poland. For her doctorate, she won a scholarship from the German Historical Institute in Warsaw.

**Prof. Dr.-Ing. Winfried Heusler**, born in 1955, studied mechanical engineering at Technical University of Munich and earned his doctorate on the topic of daylighting at TU Berlin. He has worked for Schüco International KG in Bielefeld since 1998, until 2013 as Director of Engineering and since 2014 as Head of Global Building Excellence. From 1981 to 1998, he worked as a development engineer and manager as well as head of aluminium facades at the facade construction company Gartner in Gundelfingen. He is known among experts worldwide for his numerous lectures and publications on the subject of facades. In 2004, he received an honorary professorship at the Faculty of Architecture of Kiev National University of Civil Engineering and Architecture. In 2014 he was awarded the title of Honorary Professor of Facade Design and Technology by Ostwestfalen-Lippe University of Applied Sciences and Arts.

**Knut Stockhusen**, born in 1974, studied civil engineering with Jörg Schlaich at the University of Stuttgart until 1999 and has worked for the engineering office schlaich bergemann partner since 2000 and as a partner and managing director since 2015. In 2008 he founded sbp Latin America in São Paulo, one of the five branches of the Stuttgart-based office worldwide. He specialises in the design of sports buildings, arenas and stadiums. His portfolio includes stadiums for various FIFA World Cups, UEFA European Championships and Commonwealth Games as well as for numerous European clubs, many of them with movable roof structures. He has received numerous awards for his work at home and abroad, for example for the Arena da Amazônia and

the Maracanã stadium in Brazil and most recently for the Wanda Metropolitano stadium in Spain. He gives lectures at universities and international conferences all over the world.

**Knut Göppert**, born in 1961, studied civil engineering at the universities of Stuttgart, Calgary and Karlsruhe and joined the Stuttgart office of schlaich bergemann partner in 1989. He has been a partner since 1998 and one of the office's five managing directors since 2002. Through his designs for the roofs of numerous stadiums, including those in Frankfurt, Johannesburg, Cape Town, Warsaw, Brasilia and Rio, Knut Göppert is regarded as a leading engineer in the field of wide-span structures. He has received numerous awards worldwide for his projects. He is also the author of various publications and specialist books and gives lectures around the world on lightweight construction, membranes and convertible roof constructions. Since 2013 he has been a member of the board of the Architektur-Forum Baden-Württemberg.

**Richard Murphy**, born in 1955, was educated at Newcastle and Edinburgh Universities and later taught at Edinburgh University. He founded Richard Murphy Architects in Edinburgh in 1991 and since its inception the office has won 22 RIBA Awards, two RIAI Awards in Ireland and has twice been shortlisted for the RIBA Stirling Prize and once for the RIBA Lubetkin Award. In 2017 it won the RIAS Doolan Best Building in Scotland Award for its Dunfermline Carnegie Library & Galleries. His own house in central Edinburgh won the RIBA "House of the Year" competition in 2016. Two monographs have been published on the practice's work. He is also an acknowledged authority on the Italian Architect Carlo Scarpa and has written monographs on the Castelvechio in Verona and the Palazzo Querini Stampalia in Venice as well as collaborating for a film for Channel 4. His most recent book *Carlo Scarpa and Castelvechio Revisited* was published by Breakfast Mission Publishing in 2017.

**Prof. Brian Cody**, born in 1967, is a professor at Graz University of Technology and has headed the Institute of Buildings and Energy since 2004. His focus in research, teaching and practice is on maximising the energy performance of buildings and cities. Before his appointment at Graz University of Technology he was associate director of the international engineering consultancy Arup. He is founder and CEO of the consulting firm Energy Design Cody, which is responsible for the development of innovative energy and climate control concepts on construction projects all over the world. He is a member of many advisory boards and juries and is also visiting professor and head of the Energy Design Unit at the University of Applied Arts Vienna. He is author of the book *Form follows Energy* published in 2017.

**Prof. Dr. Arno Schlüter**, born in 1974, studied architecture at TU Karlsruhe and completed his postgraduate studies in CAAD at ETH Zurich. After receiving his doctorate in 2010 on "Integration of Energy and Building Technology through Information Models", he was appointed Assistant Professor in the same year and Professor of Architecture and Building Systems at ETH Zurich in 2014. Since 2013 he has also been Principal Investigator at the Singapore-ETH Future Cities Lab (SEC FCL). His research focuses on technical building systems for energy-efficient and sustainable buildings and their integration into architecture and urban planning using data- and computer-based methods. As co-founder of the ETH spin-off KEOTO, he has been contributing to the implementation of innovative approaches in strategy, planning and construction projects since 2009.

**Dr. techn. Uta Gelbke**, born in 1979, holds a degree in architecture from the Royal Melbourne Institute of Technology. She has worked in architectural offices in Berlin, Sydney and Melbourne. From 2009 to 2014 she worked as a research assistant at the Institute of Architectural Technology at Graz University of Technology, where she completed her

doctorate on "Urban development and public space after political upheavals". She has worked as a freelance architecture journalist since 2015. She teaches, researches and writes on architectural and urban topics. Her clients include BauNetz, *Deutsche Bauzeitschrift*, ETH Zurich and the Association of German Architects. Since 2018, she has also worked as a research assistant/postdoc at the Chair of Building in Existing Contexts and Building Construction at Bergische Universität Wuppertal.

**Dr.-Ing. Philipp Lionel Molter**, born in 1976, worked for several years as an architect at Renzo Piano Building Workshop in Paris. In 2010 he founded his own office in Munich and realised several award-winning projects. His office studiomolter undertakes interdisciplinary research focussed work in the fields of architecture and design. He is academic advisor to the Professorship of Architectural Design and Building Envelope at Technical University of Munich, where he works in research and teaching on adaptive building envelopes. In 2016 he was awarded the Dr. Marschall Prize for his outstanding dissertation at the Department of Architecture of Technical University of Munich.

**Prof. Thomas Auer**, born in 1965, studied process engineering at the University of Stuttgart and has worked for the engineering office Transsolar since 1994 and as a partner since 2000. With offices in Stuttgart, Munich, Paris and New York, Transsolar develops and produces innovative concepts for buildings and neighbourhoods with the goal of improving energy efficiency and quality of life. Thomas Auer has taught at Yale University, the École Spéciale d'Architecture and Ryerson University. In 2014 he was appointed Chair of Building Technology and Climate Responsive Design at Technical University of Munich. His research and teaching focuses on climate-responsive and energy-efficient construction with an emphasis on robust optimisation.

**Dr.-Ing. Werner Jager**, born in 1966, studied mechanical engineering at Technical University of Munich. Parallel to his work at WICONA (Hydro Building Systems GmbH), he received his doctorate from the Chair of Building Physics (Prof. Dr.-Ing. Hauser) at Technical University of Munich in the field of daylight simulation of non-residential buildings. From 2014 to 2017 he was also Professor of Building Physics at Augsburg University of Applied Sciences. He is a member of the CTBUH (Council on Tall Buildings and Urban Habitat), a board member of the Green Advantage Curtain Wall Installer Certification Program, USA, and a member of the Facade Tectonics Institute, USA.

**Laura Bugenings**, born in 1994, and **Markus Schaffer**, born in 1995, were both involved as members of staff in the article “Energy generation in the city of the future”. Both completed their studies in “Energy-efficient Planning and Construction” at Augsburg University of Applied Sciences in spring 2018, producing work of outstanding quality.

**FH-Prof. DI Dr. Jürgen Neugebauer**, born in 1966, studied civil engineering at Graz University of Technology and began work in an engineering office in Graz. He had the opportunity to work on outstanding projects such as the atrium roof of the Sony Center in Berlin, the courtyard roof of the British Museum in London, and the facade of the Berlin Staatsbibliothek. He returned to Graz University of Technology to work at the Institute of Structural Design at the Faculty of Architecture, where he completed his doctoral thesis on “Glass building envelopes from the point of view of a structural engineer”. After working for a glass processing company for one year, he took up the offer to teach structural design and glass in construction at Joanneum University of Applied Sciences in Graz. In 2014 he was appointed FH Professor at the Joanneum. In 2016 he became director of the Josef Ressel Centre for Thin Glass Technology where he focuses on research into thin glass.

**Markus Wallner-Novak**, born in 1973, studied civil engineering at Graz University of Technology and also worked in an engineering office in Graz. On completing his studies, he became a university assistant at the Institute of Structural Design at the Faculty of Architecture in Graz, where he completed his doctoral thesis on “Movable structures from the perspective of structural engineering”. After three years working for TDV – Technical Data Processing for Structures and Software Development in Bridge Building, he founded Wallner, Mild Holzbau-Software Ges.b.R. where he worked independently on software development and statics in timber construction. In 2010 he held a one-year guest professorship at the Institute of Structural Design at Graz University of Technology. Since 2012 he has been a lecturer and associated professor at Joanneum University of Applied Sciences in Graz, where he teaches and researches on the topics of timber construction and the geometry and movement of thin glass.

**Dr.-Ing. Thomas Schielke**, born in 1973, studied architecture at TU Darmstadt from 1994 to 2001. For more than 15 years he has worked for the lighting manufacturer ERCO in the field of didactic communications. He is co-author of the books *Lichtpositionen zwischen Kultur und Technik* and *SuperLux – Smart Light Art, Design & Architecture for Cities*. He has taught architectural lighting at Wismar University of Applied Sciences and the University of Siegen, among others, and has been a visiting lecturer at institutions such as Harvard GSD, MIT, Columbia GSAPP, Tongji University and the ETH Zurich. He has been a regular contributor to ArchDaily publishing articles on light and architecture since 2013.

**Prof. Claudia Lüling**, born in 1961, studied at TU Darmstadt until 1989 followed by a master’s degree as a Fulbright scholarship holder at SCI-ARC in Los Angeles, where she also worked for Morphosis. After work in practice in Berlin, including project management for the Federal Printing Office’s currency printing building for BHHS architects (Bayerer, Han-

son, Heidenreich and Schuster), she worked as a research assistant at the TU Berlin and as a visiting professor at Berlin University of the Arts. In 2000 she founded her own office, from 2004 to 2009 in partnership with Ulrike Rau as Lüling Rau Architects and from 2009 to 2018 together with Christiane Sauer as Lüling Sauer Architects. She has taught as a professor at Frankfurt University of Applied Sciences since 2003 and is a founding member of the Frankfurt research institute FFin. After working on *Architektur unter Strom – Photovoltaik gestalten* (2000) and *Energizing Architecture – Design and Photovoltaics* in 2009, she shifted the focus of her teaching and research activities to innovative textile materials for lightweight construction. Her work has received numerous awards, including the Stuttgart Lightweight Structures Award 2014, the Tech-Text Award 2015, the materialPREIS 2017, the Competitionline Campus Award 2016, the AED Neuland Award 2017, the Competitionline Campus Award 2018 as well as a prize in the 2018 “Moderner Aus- und Leichtbau” university competition.

**Johanna Beuscher**, born in 1983, studied architecture at Frankfurt University of Applied Sciences until 2017. After completing her Bachelor’s degree, she took part in an Architectural Practice Program at KSP Engel Architekten in Frankfurt/Main and subsequently worked as a student trainee in the same office. She received an InWent internship scholarship to work in the USA, where she worked on spatial installations at predock frame architects, Santa Monica, and then completed one year of her Master’s degree as a full DAAD scholarship holder at SCI-ARC, Los Angeles. Back in Frankfurt, her participation in the SpacerFabricPavilion was awarded the Innovation Prize Competitionline Campus Award 2016, the materialPREIS 2017 and was also a finalist in the FAMAB New Talents Award. The project led to her invitation to lecture as a “newcomer” at the JUNG Architecture Talks, which was also published. In 2017 she joined the “Textile Lightweight Construction” group at Frankfurt University of Applied

Sciences as a research assistant, where she investigates the structural applications of spacer textiles in research projects.

**Prof. Dr.-Ing. Yenal Akgün**, born in 1978, graduated from Istanbul Technical University, Department of Architecture in 2000. After working in several national and international design projects between 2000 and 2002, he joined Izmir Institute of Technology (IZTECH) in 2002 as research assistant. In 2004, he received his MSc degree from IZTECH. In 2006, he continued his academic studies at the University of Stuttgart, Institute for Lightweight Structures and Conceptual Design through a PhD grant from the German Academic Exchange Service (DAAD), completing his PhD in 2010. He currently works as a full-time architect at the Izmir Konak Municipality Department of Urban Design and teaches at the Yaşar University Department of Architecture as a part time lecturer. He has received many awards in national architecture competitions. His research focuses on adaptive structures, lightweight structures and parametric design.

**Prof. Feray Maden**, born in 1982, studied architecture from 2000 to 2004 at the Izmir Institute of Technology (IZTECH). She started her master's studies in 2005 at IZTECH and continued her research at the KU Leuven. Her academic career began as a teaching assistant at IZTECH in 2007, where she received her MSc degree in 2008. Her PhD studies likewise began at IZTECH and continued at the Department of Architectural Engineering at TU Delft in 2012 and at the Department of Innovative Structural Design at TU Eindhoven in 2013 where she worked as a PhD researcher. She received her PhD degree in 2015 and currently works as a full-time lecturer at Yaşar University. She lectures and researches on the topics of kinetic architecture, responsive facades, structural design and parametric design.

**Prof. Gökhan Kiper**, born in 1982, studied mechanical engineering at Middle East Technical University in Ankara until 2011. During and after his doctorate he undertook research at the University of California in Davis, USA and National Cheng Kung University in Taiwan. He has been Professor of Mechanical Engineering at Technical University Izmir since 2012. He is a founding member of the Turkish Machine Theory Association (2011) and is vice chairman and secretary general of the organisation's executive board. His research focuses on mechanical science, relocatable structures and robotic kinematics.

**Prof. Koray Korkmaz**, born in 1973, heads the Department of Architecture at the Izmir Institute of Technology. He studied architecture at Dokuz Eylül University and the Izmir Institute of Technology, completing his doctorate in 2004. At the invitation of Prof. Peter McCleary, he was a visiting scholar at the University of Pennsylvania in 2004–2005. In 2008, together with Gökhan Kiper, Yenal Akgün and Feray Maden, he founded the research group MECART conducting research into deployable structures.

**Müjde Uncu**, born in 1990, studied architecture at Dokuz Eylül University in Konak/Izmir in 2013. She then continued her studies at the Izmir Institute of Technology, where she received her Master's degree in architecture in 2016. She is currently undertaking her doctorate at the same institute.

**Sebnem Gur**, born in 1985, studied architecture at Middle East Technical University in Ankara and graduated in 2007. She worked for seven years in various architectural firms and gained experience in a wide variety of projects ranging from private villas to shopping centres, schools, restoration projects, 3D modelling and animation. In 2015 she began her master's degree and graduated from the Izmir Institute of Technology in 2017. She is undertaking her doctorate at the same institute.

**Prof. Engin Aktaş**, born in 1970, studied civil engineering at Middle East Technical University in Ankara. He obtained his MSc and PhD at the University of Pittsburgh. After returning to Turkey, he joined the Izmir Institute of Technology as a lecturer. He spent a two-year period as an ASEE post-doctoral Fellow at the US Naval Research Lab in Washington DC. His research focuses on structural reliability, optimisation, structural health monitoring (SHM) and composite structures.

**Cezary M. Bednarski**, born in 1952, studied architecture in Warsaw from 1972 to 1979. He has lived in London since 1981 where he founded the Studio Bednarski in 2001. The office has received numerous awards and won 23 competitions, 13 of them for bridge projects. Bednarski is a member of the RIBA Panel of Competition Assessors, a member and former advisory board member of the Royal Society of Arts, a member of the 21st Century Trust/Salzburg Global Seminar and a former member of the Fellows Committee of the same organisation, architectural advisor to UNESCO and advisor to the Mayor of Warsaw. Among his other posts and functions are: external examiner at the University of Cardiff, research fellow ("Rome Scholar") at the British School in Rome, diploma unit master at the Architectural Association School of Architecture in London and visiting professor of architecture at the CUJAE in Havana. He was selected as one of 34 prominent Polish creatives in the exhibition "London Creatives: Polish Roots", shown at the Museum of London in 2009. In 2014, he was awarded the "Bene Merito" medal of honour by the Polish Foreign Minister, the first time the medal has been awarded to an architect.



## Acknowledgements

Responsibility for the content of the articles in this book lies with the respective contributors.

In this book, existing patents, utility models, trademarks, etc. have as a rule not been explicitly stated. Where no reference has been made, this does not imply that a product or name is not protected by law. Due to the large number of different products and names mentioned, it was not possible to check all existing rights and protection in all cases. The copyright sign (©) has as a rule been used only in the sources and acknowledgements in the appendix.

pp. 24:

Lay Light™ by Fiberline

© Fiberline Composites A/S

pp. 28–29:

The Flectofin® was developed in cooperation with ITKE (Prof. Jan Knippers, University of Stuttgart), PBG (Prof. Thomas Speck, University of Freiburg) and ITV (Prof. Götz Gresser). The One Ocean Pavilion was designed by SOMA Architects, the movable facade was constructed by Knippers Helbig – Advanced Engineering. The Flectofold was developed in cooperation with ITKE (Prof. Jan Knippers, University of Stuttgart), PBG (Prof. Thomas Speck, University of Freiburg) and ITFT (Prof. Götz Gresser, University of Stuttgart).

pp. 42–43:

Solar Curtain © Bára Finnsdóttir with Fraunhofer IWU, Dresden.

Chameleon Membrane © Madlen Deniz with Fraunhofer IWU, Dresden.

Table 1 is based on and includes information from the following sources:

Hartmut, J., *Adaptronics and Smart Structures*, Berlin Heidelberg New York, 2007, p. 153.

Langbein, S.; Czechowicz, A., *Konstruktionspraxis Formgedächtnistechnik: Potenziale – Auslegungen – Beispiele*, Wiesbaden, 2013, pp. 49–50.

pp. 50–51:

Kumo: Institute for Lightweight Structures and Conceptual Design (ILEK); Professor Werner Sobek; Supervisor: Christoph Witte, Stefan Neuhäuser; Students: Amlis Botsch, Carolin Forster, Orestis Gkouvas, Nicola Haberbosch, Franziska Hann, Julia Heibaum, Jannik Lambrecht, Francisco Pérez Florido, Takashi Sato, Michael Schnell, Andreas Schönbrunner, Jonas Unger, Johanna Zinnecker; Year: 2011.

Paul: Institute for Lightweight Structures and Conceptual Design (ILEK); Professor Werner Sobek; PhD student: Markus Holzbach; Duration of the pavilion and exhibition: 2004–2009.

Stuttgart SmartShell: Institute for Lightweight Structures and Conceptual Design (ILEK); Professor Werner Sobek; PhD student: Stefan Neuhäuser; Institute for System Dynamics (ISYS); Professor Oliver Sawodny; PhD student: Martin Weickgenannt; Year: 2012.

Collaborative Research Center 1244 – “Adaptive Building Skins and Structures for the Built Environment of Tomorrow”:

Chair: Professor Werner Sobek, Institute for Lightweight Structures and Conceptual Design (ILEK)

Vice-chair: Oliver Sawodny, Institute for System Dynamics (ISYS)

Participating Institutes at the University of Stuttgart:

Institute for Acoustics and Building Physics (IABP)

Institute for Structural Mechanics (IBB)

Institute for Computational Design and Construction (ICD)

Institute of Aircraft Design (IFB)

Institute of Industrial Manufacturing and Management (IFF)

Institute for Engineering Design and Industrial Design (IKTD)

Institute for Lightweight Structures and Conceptual Design (ILEK)

Institute of Machine Components (IMA)

Chair of Macromolecular Materials and Fiber Chemistry, Institute of Polymer Chemistry (IPOC)

Institute for System Dynamics (ISYS)

Institute of Engineering and Computational Mechanics (ITM)

Institute of Applied Optics (ITO)

Institute for Visualisation and Interactive Systems (VIS)

Visualisation Research Centre (VISUS)

External research institutes:  
 Fraunhofer Institute for Building Physics (IBP)  
 Professor of Architecture and Art, HafenCity University of Hamburg  
 Professor of Temporary buildings, University of the Arts Bremen

Homepage: [www.sfb1244.uni-stuttgart.de](http://www.sfb1244.uni-stuttgart.de)

pp. 84–87:

The content of the article draws on research carried out at the Josef Ressel Centre for Thin Glass Technology for Applications in the Building Industry in cooperation with the industry partners LISEC Austria GmbH and SFL Engineering GmbH within the framework of a research project funded by the Christian Doppler Research Society.

All rights to the text and content are copyright © Jürgen Neugebauer – Josef Ressel Centre for Thin Glass Technology for Applications in the Building Industry.

pp. 94–97:

The text is based on results of the R&D project Re-FaTex, “Reversible, Foldable, Energetically-effective 3D textiles in the building industry” (IFOFO grant funding), Prof. Claudia Lüling, Staff: M. A. Johanna Beuscher, Dipl.-Ing. Natalija Miodragovic. Tutors: Philipp Cronenberg, Rasmus Kallenberg, David Knecevic, Eugen Kraus, Ivan Litvitschenko, Marius Mersinger. [www.fabricfoam.de](http://www.fabricfoam.de) © All research results are rights protected.

Drawings in Part C

Unless otherwise indicated, all drawings were produced by Team New Move especially for this book or redrawn from original artwork. The following architects, engineers, technical planners and other project participants and their offices supported the team and provided original drawings. The rights to these drawings remain with their respective authors and may only be cited under inclusion of the author-

ship as indicated below along with the addition “© New Move”.

pp. 108–109: © Isay Weinfeld

pp. 110–111: © Nextoffice + © Alireza Taghaboni

pp. 112–113: © PPAG architects

pp. 114–115: © Olafur Eliasson

pp. 116–117: © McDowell + Benedetti Architects, © Alan Baxter Ltd.

pp. 119–119: © Shigeru Ban Architects, © Jean de Gastines Architectes

pp. 120–121: © Estudio Guto Requena

pp. 122–123: © OMA

pp. 124–125: © charles barclay architects

pp. 126–127: © urbanekultur

pp. 128–129: © matharoo associates

pp. 130–131: © ISC Consulting Engineers A/S, © Bystrup Arkitekter

pp. 132–133: © heatherwick studio

pp. 134–135: © marchi architects

pp. 136–137: © Walter Bieler AG, © exent AG

pp. 138–139: © nex-architecture

pp. 140–141: © Studio Bednarski, © COWI UK Limited

pp. 142–143: © Foster + Partners

pp. 144–145: © Werner Sobek Group GmbH

pp. 146–147: © sean godsell architects

pp. 148–149: © Manuel Herz Architects

pp. 150–151: © MADE IN

pp. 152–153: © Renato Rizzi, © Proteco Engineering S.r.l.

pp. 154–155: © DPA – DOMINIQUE PERRAULT ARCHITECTURE

pp. 156–157: © Make Architects

pp. 158–159: © Architekten Cie B.V., © euro-deur – NL

pp. 160–161: © Softarchitecturelab

pp. 162–163: © GEISWINKLER & GEISWINKLER Architekten ZT GmbH

pp. 164–165: © Nickl & Partner Architekten

pp. 166–167: © AHR

pp. 168–169: © Charles Sowers Studios, LLC, © San Francisco Arts Commission

pp. 170–171: © Charles Sowers Studios, LLC, © Shawn Lani Studios, © Peter Richards Art, © High Precision Devices, Inc.

pp. 172–173: © matharoo associates

pp. 174–175: © NEY & PARTNERS BXL

pp. 176–177: © knight architects

pp. 178–179: © knight architects

pp. 180–181: © raum.fr

pp. 182–183: © B-L Barkow Leibinger

pp. 184–185: © stacklab.ca

pp. 186–187: © Kennedy & Violich Architecture, © Knippers Helbig, Stuttgart – New York – Berlin

pp. 188–189: © iArt AG, © Asif Khan Ltd.

pp. 190–191: © soma architecture, © Knippers Helbig, Stuttgart – New York – Berlin

pp. 192–193: © yuya vs design

pp. 194–195: © Klemens Torggler – visual artist

pp. 196–198: © matharoo associates, © Ramana Safety and Systems (I) pvt. Ltd. by Mr. Ramesh Sheth & Mr. Harshad Gajjar

pp. 198–199: © Ingeni Ingenieure

pp. 200–201: © heatherwick studio, © Foster + Partners

pp. 202–203: © Ateliers Jean Nouvel, © DVVD architectes, ingenieurs, designers, © IMARABE ORG

## Illustration credits

Page 8 kisscc0; 9 top © Luis Cordón; 9 bottom © Vepa the furniture factory – the Netherlands; 10 right © schneider+schumacher; 10 left © thyssenkrupp Elevator; 11 top and bottom © ICD Universität Stuttgart; 12 top and bottom © 2019 Österreichische Friedrich und Lillian Kiesler-Privatstiftung; 13 right and left © Lev Nussberg; 14 top © Audi Urban Future Award 2014 Team Berlin/Studio Schwitalla; 14 bottom © Studio Schwitalla/Schindler Elevator Ltd and © Audi Urban Future Award 2014 Team Berlin/Studio Schwitalla; 15 top © Studio Schwitalla/Schindler Elevator Ltd

### A

18 top FTL Design Engineering Studio/Winquist Photography; 18 bottom BMW AG; 19 top Transport for New South Wales; 20 top Bastian Mueller & Natalie Weinmann; 20 bottom Studio Thier&vanDaalen, Eric Esser, Levi's ©; 21 top ludwig.schönle, studio aisslinger; 22 © Premium\_AEROTEC; 23 © Premium\_AEROTEC; 24 © Fred Romero; 25 © Carsten Schmidt based on the respective sources given; 26 © Bipinchandra Mistry; 27 © Bipinchandra Mistry; 28 top © William Warby; 29 bottom © ITKE Universität Stuttgart/Ruslou Koorts, © ITKE Universität Stuttgart/Dr. Julian Lienhard; 30 top Eric Staudenmaier, www.gobytram.com; 31 top agps architecture, Zurich-Los Angeles/Eric Staudenmaier, agps architecture, Zurich-Los Angeles/ www.gobytram.com; 34 bottom © Alexander Graham Bell; 35 top © Ryan Burke and © Amazon Robotics; 36 top © Samuel Leder, Ramon Weber; 37 bottom © BART//BRATKE;

38 Arup/davidfotografie; 40 New Move based on original material on the stress ribbon bridge © ek massivbau/TU Berlin. All drawing rights remain with the originator(s); 41 top © ek massivbau/TU Berlin; 41 bottom © Team New Move; 42 top © Solar Curtain, FG Textil- und Flächendesign/Bára Finnsdóttir with Fraunhofer IWU Dresden; 42 bottom Chamäleon Membran © weißensee kunsthochschule berlin, FG Textil- und Flächendesign/Madlen Deniz with Fraunhofer IWU Dresden; 43 top © Solar Curtain, FG Textil- und Flächendesign/Bára Finnsdóttir with Fraunhofer IWU Dresden; 44 top © Festo AG & Co. KG, all rights reserved; 44 bottom Francois Mangion & Bijing Zhang, Interactive Architecture Lab, Bartlett School of Architecture, University College London, London UK; 45 top © Festo AG & Co. KG, all rights reserved

### B

48 top © Carl Hansen & Søn; 48 bottom left © Joval; 48 bottom centre and right © Tojo; 49 top left © TECTA; 49 top right © Olaf Schroeder; 50 top © ILEK\_G. METZER; 51 top © ILEK\_G. METZER; 51 bottom © G.METZER; 52 top © ILEK\_G.METZER; 53 top © ILEK\_G. METZER; 54 top © Schüco International KG; 55 top New Move based on original material from © schüco. All drawing rights remain with the originator(s); 55 bottom © JensLindhe/BBP Arkitekter, Ebbe Wæhrens; 56 top New Move – NL based on original material from © schüco. All drawing rights remain with the originator(s); 57 top platform\_a – © Joon Joonhaw; 58 top © Photogra-

phy: Michael Elkan; 58 bottom © sbp de; 59 top © sbp de; 60 top © sbp de/Knut Stockhusen; 61 top © sbp de; 62–65 © Keith Hunter; 68 top © Brian Cody; 69 New Move based on original material from © Brian Cody. All drawing rights remain with the originator(s); 70 left New Move based on original material from © Brian Cody. All drawing rights remain with the originator(s); 70 right © Brian Cody; 71 top New Move based on original material from © Brian Cody. All drawing rights remain with the originator(s); 72 bottom left © ETH Zürich/Marco Carocari; 72 bottom right © A/S Research Group; 73 top © AHR/Christian Richters; 74 © A/S Research Group; 75 © A/S Research Group; 76 bottom © Philipp Lionel Molter; 77 top left © Philipp Lionel Molter; 77 top right © Johannes Maderspacher; 78 © Philipp Lionel Molter; 79 © Philipp Lionel Molter; 80 top © New Move; 80 bottom © HLNUG – Background map © GeoBasis-de/BKG 2017, ©Hessische Verwaltung für Bodenmanagement und Geoinformation, Fachdaten: Hessisches Landesamt für Naturschutz, Umwelt und Geologie; 81 © R. R. Lunt, Michigan State University; 82 top © New Move; 83 top WICONA – Conné van d'Grachten; 84 bottom © Jürgen Neugebauer, 85 top © Jürgen Neugebauer, 86 top © Jürgen Neugebauer; 87 top © Jürgen Neugebauer; 90 bottom space150 – © The Coca-Cola Company; 91 top © Jochen Stüber; 92 top Copyright der Daimler AG; 93 Ars Electronica Spaxels over Linz – credit: vog.photo; 94–97 © FRA-AUS; 98–101 © Akgün et al.; 102 top New Move based on original material from Agostino Ramelli: RAMELLI, Agostino; Paris,

1588, Le diverse et artificieuse Machine, figvre CX-LVII, S. 241; 102 bottom © Cezary Bednarski, © Tomoaki Uji and © Ian Boyle – Simplon Postcards; 103 top © Studio Bednarski; 104 bottom left spb – © Till Beckmann; 104 bottom right © steve cadman; 105 top © Studio Bednarski

## C

108 © Leonardo Finotti; 110 nextoffice – © Parham Taghioff; 112 © pierer.net; 114 Anders Sune Berg – © Olafur Eliasson; 116 © Timothy Soar; 118 Shigeru Ban Architects – © Didier Boy de la Tour; 120 Estudio Guto Requena – © Fernanda Ligabue & Rafael Frazão; 122 OMA – photograph by John Gollings, courtesy of MPavilion; 124–125 © Charles Barclay; 126 urbanekultur – © jbd; 128–129 matharoo associates – © Edmund Sumner; 130 Jysk Fynske Medier – © John Fredy and © Nils Svalebø; 132 © Cristóbal Palma; 134 Marchi Architectes – © Fernando Guerra; 136 Walter Bieler AG – © Bowie Verschuuren; 138 nex-architecture – © Joseph Asghar; 140–141 © Studio Bednarski; 142 Nigel Young/© Foster + Partners; 144 Werner Sobek Group – © Zoëy Braun; 146 top © sean godsell architects; 146 bottom sean godsell architects – © Earl Carter; 148 top © Manuel Herz Architects; 148 bottom Manuel Herz Architects – © Yuri Palmin; 150 top © MADE IN; 150 bottom © Joël Tettamanti; 152 top and bottom Renato Rizzi, with Proteco Engineering S.r.l. – © Matteo Piazza; 154 top © DPA/Adagp; 154 bottom © DPA/Adagp – © Georges Fessy/DPA/Adagp; 155 New Move based on original material from © FCC Construcción. All drawing rights remain with the originator(s); 156–157 bottom © Make Architects; 158 bottom Architekten Cie B.V. – © Rob Hoekstra; 160 top © softarchitecturelab; 160 bottom softarchitecturelab – © Shin Kyungsub, softarchitecturelab – © Shin Kyungsub and © softarchitecturelab; 162 © Manfred Seidl, Vienna; 164–165 bottom © Stefan Müller-Naumann; 166 top © Christian Richters; 166 bottom © Christian Richters, © AHR; 167 bottom © AHR; 168 top and bottom Charles Sowers

Studios, LLC – © San Francisco Arts Commission; 170 top New Move based on original material from © Charles Sowers Studios, LLC, © Shawn Lani Studios and © Peter Richards Art. All drawing rights remain with the originator(s); 170–171 bottom © ShawnLani Studios; 172 bottom © matharoo associates – © Dinesh Mehta; 174–175 NEY & PARTNERS BXL – © J. L. Deru/photo-daylight.com; 176 top © Patrick Reynolds; bottom © Patrick Reynolds, © Patrick Reynolds, © knight architects; 178 top © Peter Cook; bottom © Edmund Sumner, © Edmund Sumner, © knight architects; 180 top © raum; 181 bottom © raum; 182 top © B-L Barkow Leibinger; 182–183 bottom B-L Barkow Leibinger – © Johannes Förster; 184 top New Move based on original material from © stacklab.ca. All drawing rights remain with the originator(s); 184 bottom © stacklab.ca; 185 centre left © stacklab.ca; 186 top Kennedy & Violich Architecture – © Michael Moser; 186 bottom © Kennedy & Violich Architecture; 188 top © iArt AG; 188 bottom Asif Khan Ltd. – © Hufton + Crow; 189 bottom Asif Khan Ltd. – © Axis; 190 top © soma; 190 bottom © Kim Yong-Kwan; 191 bottom © Knippers Helbig; 192 top New Move based on original material from © yuya vs design. All drawing rights remain with the originator(s); 192 bottom © yuya vs design; 194 top New Move based on original material from the Deutsches Patent- und Markenamt with No.: DE 202012000999 U1/Means for closing an opening. All drawing rights remain with the originator(s); 194–195 bottom © Klemens Torggler – visual artist – © torggler & avincze; 196 matharoo associates – © Edmund Sumner; 198 top New Move based on original material from © Ingeni Ingenieure. All drawing rights remain with the originator(s); 198 bottom © Adrien Barakat; 200 top and bottom © Laurian Ghinitoiu; 201 centre left © heatherwick studio and © Foster + Partners; 202 top New Move; 202 bottom © Georges Fessy, IMARABE.ORG – © Fabrice Cateley and IMARABE.ORG – © Fabrice Cateley

## Illustrations for sponsors

219 WICONA bottom De Rotterdam – Photos: Michel van de Kar, Charlie Koolhaas, Ossip van Duivenbode, Philippe Ruault, Fornebuporten – Photos: Hufton + Crow, 520 West 28th – Photos: Hufton + Crow; 220 Schüco – 3XN Architects

Despite every effort to trace and credit the originators of illustrations, we cannot rule out the possibility of error. Their copyright remains unaffected. In such cases, please notify us accordingly. Unless otherwise indicated, all drawings have been made especially for this book. The rights for these lie with the respective authors and/or originator(s).



## Sponsoring companies

Hydro Building Systems Germany GmbH  
**Technology for Ideas: Facades, windows and doors**  
[www.wicona.de](http://www.wicona.de)

### **A competent partner for customised facade solutions**

WICONA creates sophisticated, functional and energy-efficient facades of the highest quality. Each project takes the client's respective design intentions and technical requirements as the basis for the design and realisation of a customised facade solution.

One of the greatest challenges in the present day is to create buildings that are architecturally ambitious and also ecologically responsible, sustainable and respect the climate. Of particular relevance are concepts that conserve resources, offer a high level of user comfort and promote health at work and in the home. At the same time, in view of rising energy prices, they must be economically attractive for building owners and tenants in the long term. WICONA recognised this years ago and has adapted

accordingly. The company has the necessary expertise to turn the ideas of planners and architects into reality within the given economic constraints. Numerous projects that have been awarded building certificates such as DGNB, LEED, Passive House or Minergie are the product of creative, constructive and successful collaborations between clients, planners, facade builders and the aluminium systems company.

WICONA's slogan "Technology for Ideas" epitomises the principle of successful partnership to produce customised solutions for clients. WICONA acts as a bridge between the creative planning services of architects and designers and the technical implementation of facade construction companies. Planning and building demand a high degree of creativity and design freedom from all parties involved. WICONA facilitates this dynamic process by provid-

ing know-how, high-tech products and comprehensive service. "Technology for Ideas" also means communicating actively with customers and business partners. Suggestions and requests from partners are examined and incorporated into the development process. WICONA provides architects and metal producers with tailor-made technology to find the best possible solution to realising their individual ideas.



## Sponsoring companies

Schüco

**System solutions for windows, doors and facades**  
www.schueco.com

The Schüco Group, with its headquarters in Bielefeld, develops and supplies system solutions for building envelopes made of aluminium, steel and plastics. With 5,400 employees worldwide, the company consistently strives to lead the industry through technological innovation and expert service, today and in the future. Schüco's product portfolio ranges from windows and doors to facade, security and sun protection systems.

In addition to supplying innovative products for residential and commercial buildings, the building envelope specialist provides consultation and digital solutions for all phases of a building project – from the initial idea through to design, fabrication and assembly. 12,000 fabricators, developers, architects and investors around the world work together with Schüco. The company is active in more than 80 countries and achieved a turnover of 1.670 billion euros in 2018.

Hawa Sliding Solutions AG

**Inspiring sliding solutions**  
www.hawa.com

With over 50 years' expertise in the development of sliding solutions, Hawa Sliding Solutions AG is the global technology and market leader for sliding solutions in interiors and furnishings. With a comprehensive range of fittings, Hawa has an optimum solution for every challenge in the design of buildings, interiors and furniture.

Innovative sliding solutions – such as a soundproofing sliding door – have the capacity to improve modern architecture, making rooms more beautiful and functional and more economical and flexible. Hawa Sliding Solutions' product range has an appropriate solution for almost every situation, material and door weight and caters for all common sliding forms from horizontal and vertical sliding and folding systems to stacking and pivot/slide-in mechanisms. Hawa Sliding Solutions is a reliable partner for sophisticated architectural projects.

Vitra

**Furniture and dynamic room concepts**  
www.vitra.com

Vitra works with leading designers to develop innovative furniture and concepts. Designed in Switzerland, they are used all over the world by architects, companies and private users to create inspiring environments.

Vitra's furniture classics include some of the most pioneering designs of the 20th century. Today, Vitra continues to push forward the boundaries of design, combining its technical know-how with the creativity of contemporary designers.

A family business for 80 years, Vitra believes in lasting relationships with customers, employees and designers, durable products, sustainable growth and the power of good design.

The Vitra Campus, the Vitra Design Museum, the design archives and the company's comprehensive furniture collection are all part of Vitra. They inspire visitors, inform the design process and create an atmosphere in which innovation can flourish.



HIRT swiss descending windows Germany GmbH  
**Descending window fronts**  
[www.hirt-swiss.de](http://www.hirt-swiss.de)

With more than 20 years' experience, HIRT swiss descending windows is the global market leader in the field of retractable glass fronts and facade elements. With headquarters in Zurich and a German branch office in Cologne, the company can point to over 350 pioneering projects worldwide that demonstrate HIRT's unique expertise in the field. Innovative, precise and perfectly coordinated construction, drive mechanism and control systems as well as contemporary design elegance are the most important features of HIRT's durable and reliable product lines. Our facade elements retract at the push of a button and are available in a range of sizes – SF 90 (up to 6 × 3 m), SF XL (up to 12 × 4 m) and SF Special – to cater for the most diverse size, function and shape requirements. HIRT's descending window fronts can be manufactured flat, as corner solutions, postless or rounded in a wide range of materials. The company provides a comprehensive spectrum of services for the entire planning process from conception, work planning and coordination with the overall planning process to production and assembly.



FSB Franz Schneider Brakel  
**Door and window hardware**  
[www.fsb.de](http://www.fsb.de)

FSB is a synonym the world over for visually and functionally perfected system solutions for doors and windows, electronic access control and barrier-free sanitary equipment.

For architects and their clients, FSB's excellent design competence and advanced understanding of the requirements of modern building construction is a direct asset: everything that has to do with gripping and handles in built spaces is catered to from a single source. For FSB, the building shell and interior are a total work (of art) – and the handle in turn the elementary interface between humans and architecture.

At FSB, architectural trends are not just followed but also set and serviced to perfection: push handles for doors and windows, flush-mounted roses, satin-matt blasted aluminium surfaces in various anodised colours and much more delight both hand and eye.

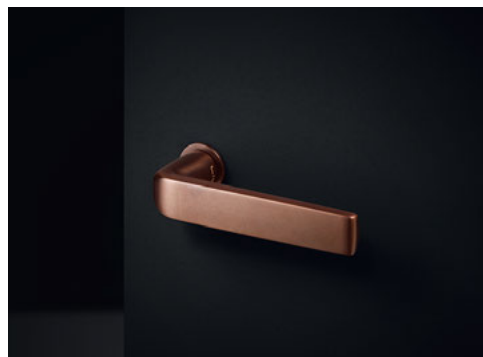



**Layout and cover design**

Miriam and Jeanne Bussmann, Berlin

**Translation**

Julian Reisenberger, Weimar

(except articles by Richard Murphy, Brian Cody, Yenal Akgün et al. and Cezary M. Bednarski)

**Editor for the publisher**

Andreas Müller, Berlin

**Production**

Heike Stempel, Berlin

**Paper**

150 g/m<sup>2</sup> Condat matt Perigord

**Printing**

Grafisches Centrum Cuno GmbH & Co. KG, Calbe

**Cover – lenticular printing**

Pinguin Druck, Berlin

**We wish to thank the following companies for their participation in this book**

Franz Schneider Brakel GmbH + Co KG

Hawa Sliding Solutions AG

HIRT swiss descending windows Deutschland GmbH

Hydro Building Systems Germany GmbH

Schüco International KG

Vitra GmbH

Library of Congress Control Number: 2019952519

Bibliographic information published by the German National Library

The German National Library lists this publication in the Deutsche Nationalbibliografie.

Detailed bibliographic data are available on the Internet at <http://dnb.dnb.de>.

This work is subject to copyright. All rights are reserved, whether the whole or part of the material is concerned, specifically the rights of translation, reprinting, re-use of illustrations, recitation, broadcasting, reproduction on microfilms or in other ways, and storage in databases. For any kind of use, permission of the copyright owner must be obtained.

This publication is also available as an e-book (ISBN 978-3-0356-1362-9) and in a German language edition (ISBN 978-3-0356-1353-7).

© 2020 Birkhäuser Verlag GmbH, Basel

P.O. Box 44, 4009 Basel, Switzerland

Part of Walter de Gruyter GmbH, Berlin/Boston

Printed on acid-free paper produced from chlorine-free pulp. TCF ∞

Printed in Germany

ISBN 978-3-0356-1360-5

9 8 7 6 5 4 3 2 1

[www.birkhauser.com](http://www.birkhauser.com)

