

LAYOUT & COMPOSITION
LETTERING

3

LETTERING LAYOUT & COMPOSITION

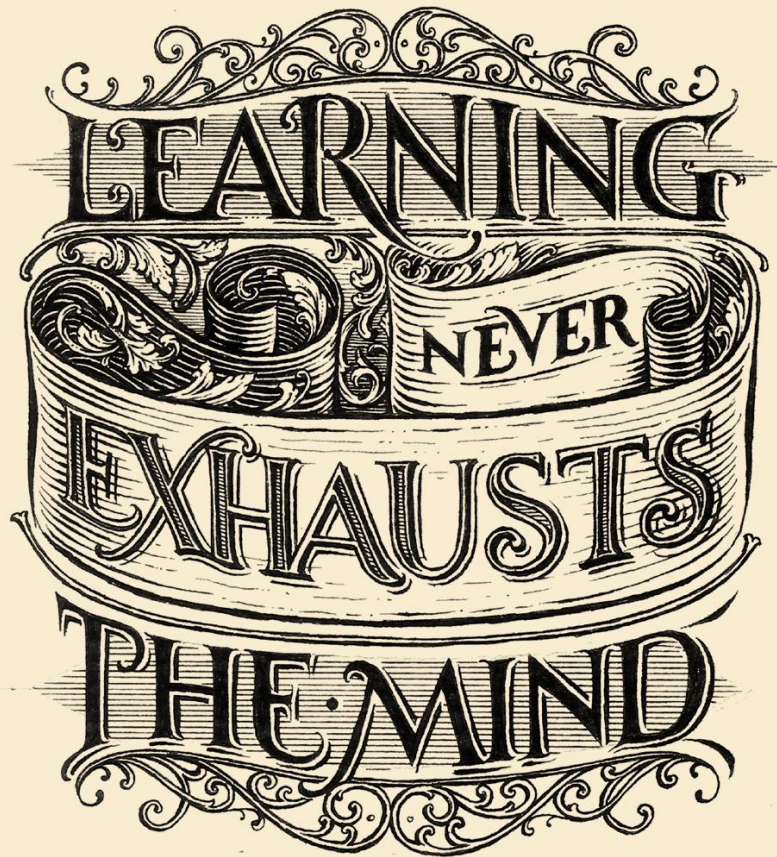

QUOTE LETTERING

Lettering is the art of drawing letters to enhance the aesthetics and main theme of a certain content (usually a single word or short quote.) In particular, Quote Lettering is one of the most popular divisions. Basically, Quote Lettering is how I name short-content calligraphy like a sentence or a verse. Thanks to well-designed layouts and different drawing techniques, the content will be highlighted so that its message is conveyed better.

In this document, I will share some lettering techniques for short content (usually, more than 4 words and less than 12 words) with Roman used as the main font. Besides layout arrangement and text priority, we will also learn how to customize details, change the basic shape, or add extra elements such as lines or banners to bring the drawing to perfection.

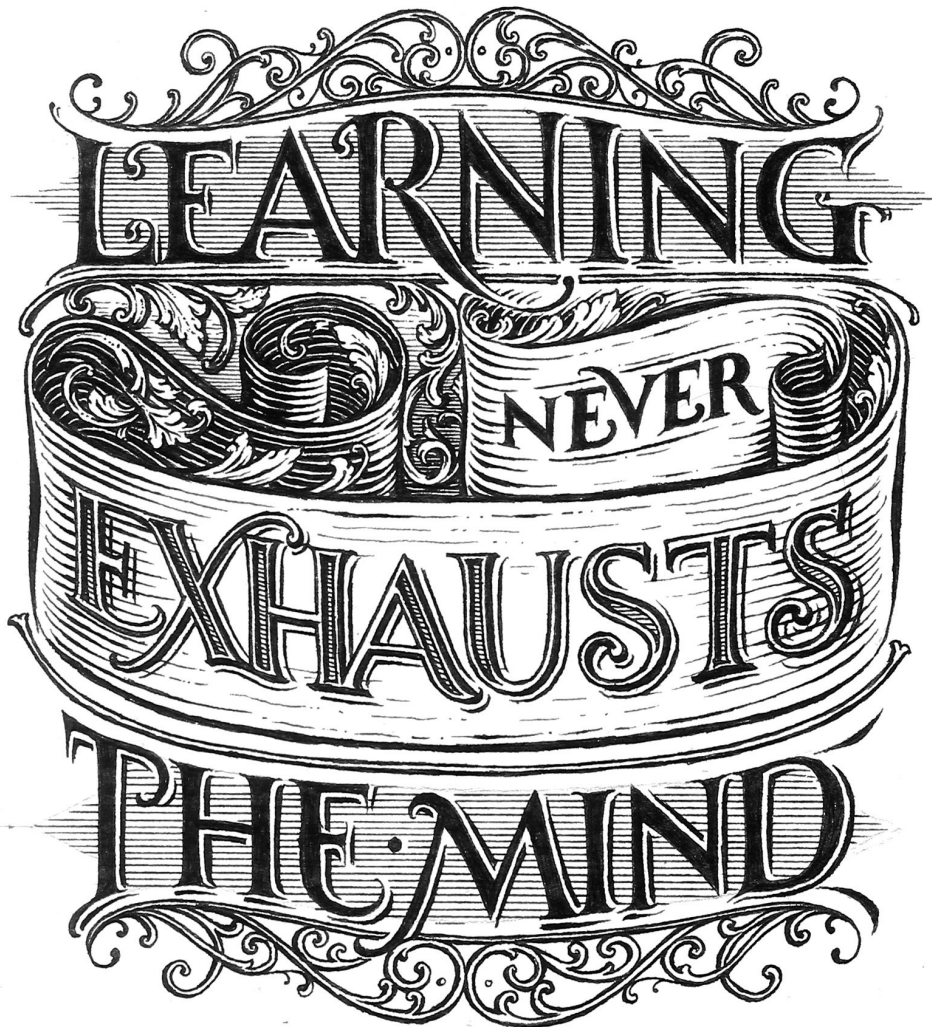

An example for Quote Lettering "Learning never exhausts the mind." - Da Vinci

BASIC SHAPES

The general shape is the first thing we need to consider. It is the physical outline of the whole content, which means that the content can be in any shape we predetermine: rectangle, square, ladder, round or oval. Sometimes, it could be the shape of a cup, a harp, etc.

Usually, basic shapes will include symmetrical figures such as rectangle, trapezoid, circle and square to ensure the visual harmony of the drawing.

Rectangle shape

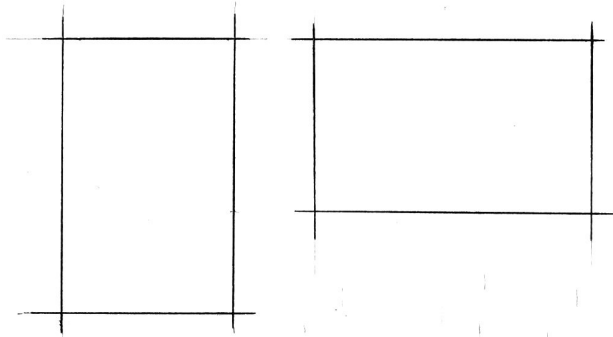

The rectangle is considered the safest shape for a lettering design. Depending on the length of content, we decide its shape direction to be either portrait or landscape. The horizontal : vertical ratio is adjustable. However, my recommendation is no less than 1 : 2 (To avoid too narrow design).

Square and rhombus shape

Thanks to equal-length sides, square and rhombic shapes form an ideal balance. With this shape, the content will be controlled in an even space. The rhombus will create a stronger and more impressive form than square yet harder to balance the harmony.

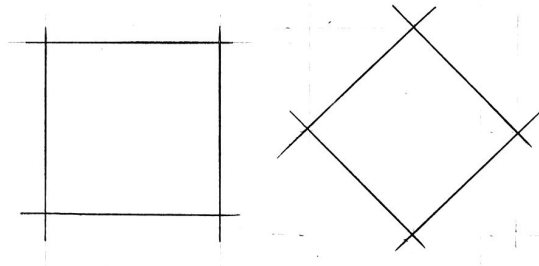

Trapezoidal and triangular shape

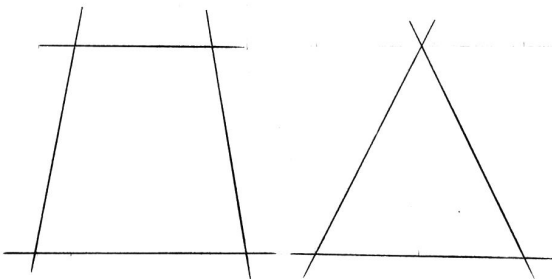

They are well-proportioned shapes that always have a certain axis. The uniqueness of a trapezoid or triangle is its imbalance between the sides (For example, the top and bottom sides of a trapezoid have different lengths). In these shapes, both primary and secondary elements need to be properly arranged to avoid the content being burdened or tilted on one side.

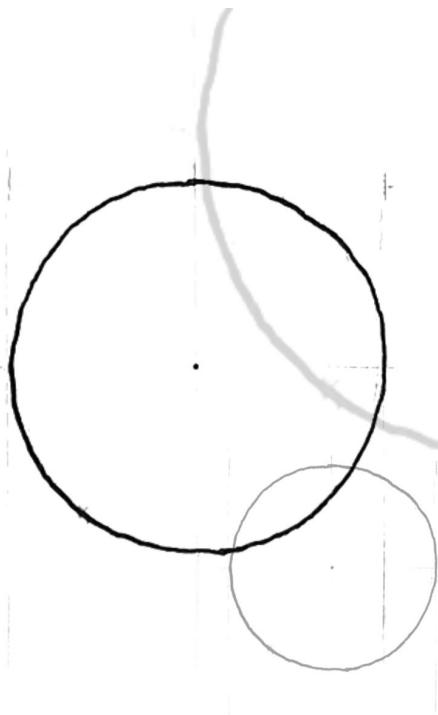

Round shape

In fine art generally, the circle is always considered a special shape. Thanks to its closed-form without edges, the circle creates absolute visual harmony. No-edge shape makes it both easy and difficult to do.
 Easy - With its balance, the layout arrangement will be supported better.
 Difficult - Because there is no element to firmly place the entire content, the drawing can become less sturdy.

2. LAYOUT

Layouting is the art of arranging content, letters and details to form a harmonious block in the basic shape mentioned in the previous section. In general, it is how we divide the main and secondary elements based on their size, shape variations as well as details of each part. Then, composite them into one content.

For example, we have the content "A B C D", in which A and C are more important elements while B and D only play a supporting role. Now, A and C will be highlighted by changing their magnitude and positions, or by creating variations with special shapes and details.

"ART · IS · A · LINE · AROUND · YOUR · THOUGHTS."

For the first example, I will choose Gustav Klimt's famous saying "Art is a line around your thoughts". I can break this sentence into 4 parts: Art/is a line/around your/thoughts and put them into the following forms.

Left-right alignment

The most fundamental kind of arrangement is the left-right alignment. However, the layout can probably lose its balance towards one direction.

ART	ART
IS · A · LINE	IS · A · LINE
AROUND · YOUR	AROUND · YOUR
THOUGHTS.	THOUGHTS.

ART	← ART →
IS · A · LINE	← IS · A · LINE
AROUND · YOUR	← AROUND · YOUR
THOUGHTS.	← THOUGHTS.

Center and free alignment

Free alignment is a way to ensure the balance and visual harmony of the whole drawing. Free-form composition depends on personal artistic taste.

Letter height and line spacing

The line spacing is adjustable depending on the size of letters. It can be the same, bigger, or smaller than the letter height. In the following examples, I will choose center alignment with the letter height called H to perform different ways of measuring line spacing.

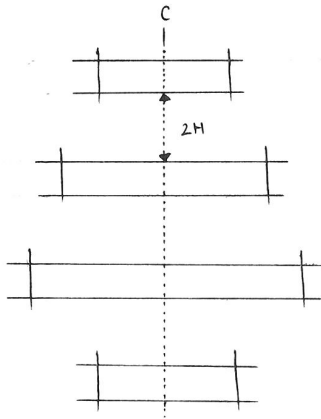

*Equal to two times of the letter height
(To create a shape portrait)*

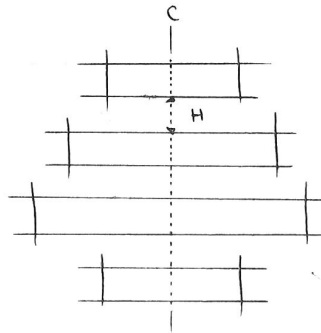

*Equal to the letter height
(To create a square shape)*

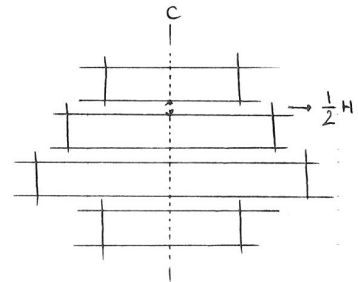

*Equal to half of the letter height
(To create shape landscape)*

Based on the above steps, we can see that the general shape of content still depends on letter height and line spacing. Therefore, our initial choice for the content shape is not fixed. If you still want to keep the original shape, then you should add extra details such as ornaments and banners to balance the layout (This section will be introduced later). Going back to what we're doing, I will choose a line spacing equal to the letter height.

Letter length and line spacing

After balancing the letter height and line spacing, we will continue editing the manuscript by putting letters to each line for length comparison. At this point, the main and secondary elements will be balanced in size while line spacing will be adjusted depending on those elements.

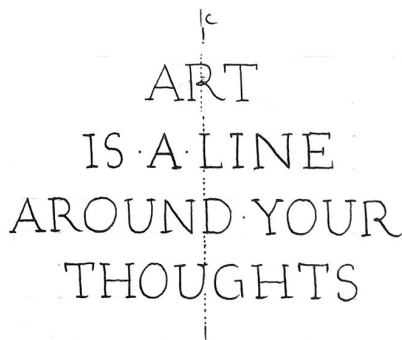

This sketch is drawn with the first layout and unchanged letter size. In this layout, we can easily notice a big gap between each letter's length, making the drawing imbalance. Therefore, I will resize those elements to bring back the visual harmony.

ART
IS A LINE
AROUND YOUR
THOUGHTS

Based on the meaning of the sentence, I will divide the main - sub order as follows: the main element is the word ART, supporting elements are IS A LINE and THOUGHTS with the same size, and finally AROUND YOUR. Now, the composition has become more balanced and consistent with the whole drawing.

The simple example above has helped us understand a part of the initial process of layout arrangements. However, the drawing can be repetitive and dull if each letter's shape is kept neatly in line. Although changing the shape is not always necessary, it can highlight the text effectively. Therefore, in the following section, we will learn how to customize the text.

Change the shape of the text

There are several ways to change the text shape. What we need to focus on is maintaining visual harmony and correlation among those shapes.

Basic Technique 1: Bending

Bending is a way to change the curvature of one or more edges within a text shape. Have a look at the following examples to learn more.

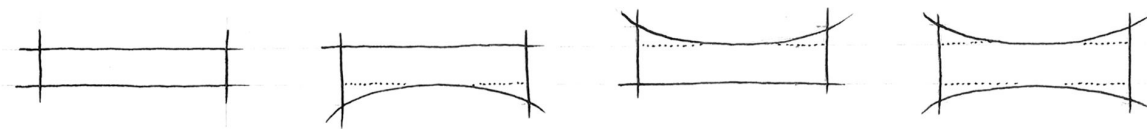

Bending inward the text shape

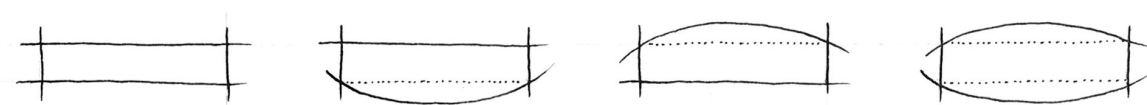

Bending outward the text shape

Basic Technique 2: Drag the corner

By changing the position of the corners, we can create several variations such as parallelogram, horizontal trapezoid, etc.

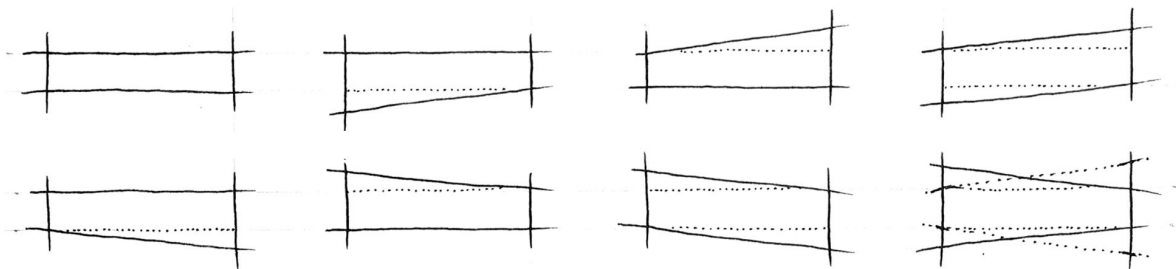

Besides basic shapes, we can even create smoother and more impressive variations.
Below are some shapes for reference.

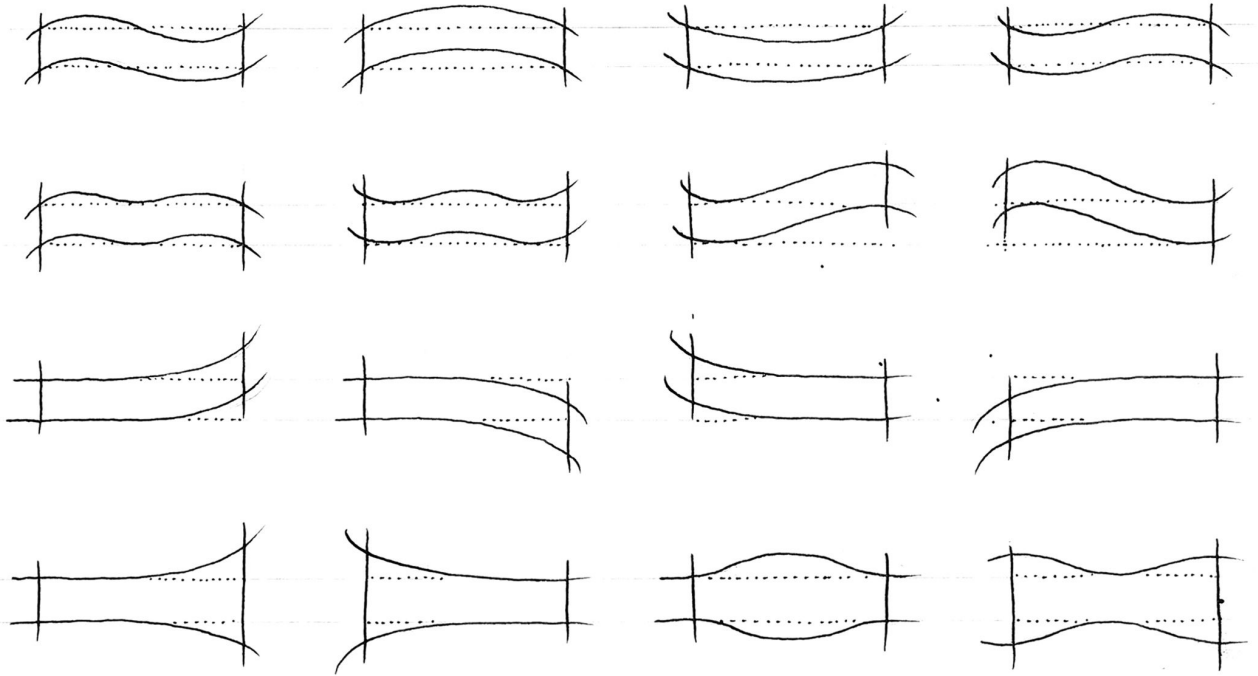

How to change the shape of the text

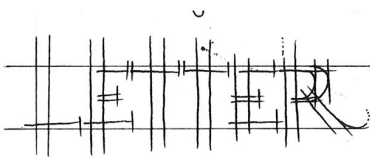

By changing the position of the corners, we can create several variations such as parallelogram, horizontal trapezoid, etc.

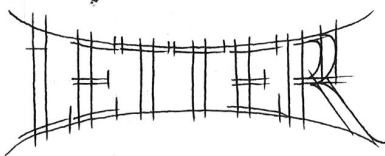

Besides basic shapes, we can even create smoother and more impressive variations. Below are some shapes for reference.



Finally, complete the text and remove the original outline.

LETTER LETTER LETTER

Other examples

After finishing all steps from choosing the drawing shape to arranging the layout, calibrating line spacing as well as letter height and shape, depending on personal preferences, we can arrange details in the most harmonious way. Below is an example of the draft and final layout version for “Art is a line around your thoughts”. Additional details will be described and guided in the following sections.

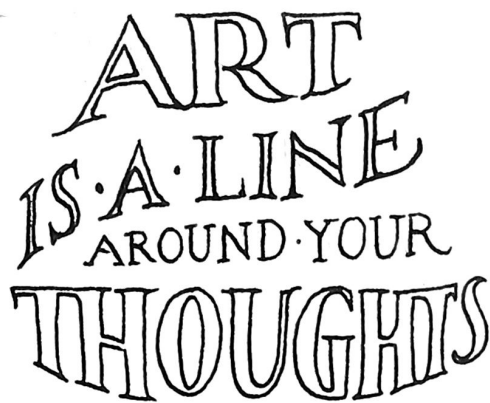

ART
IS · A · LINE
AROUND · YOUR
THOUGHTS

In this example, to rebalance the composition, I will increase the font size of the word ART and THOUGHTS. As discussed in the previous section, the next important element is IS A LINE. Also, AROUND YOUR will be drawn as a simpler drawing cluster than the rest to avoid any rivalry in the composition.



ART
IS · A · LINE
AROUND · YOUR
THOUGHTS

Depending on the content, we can decide if the drawing needs additional details or not. In this example, I use a number of supporting strokes to increase the aesthetics as well as customize details of letters. In the next section, we will have a clearer look at those factors.

3. THE VARIATION OF LETTERS

In this document, I will use Roman for lettering description and guidance. Overall, Roman is a standard typeface, suitable for both basic and advanced drawings. With a balanced, simple and standard letter shape, practicing with Roman typeface will give you a better overview of layout arrangement and element variations in general.

The format of the letter

We can have different formats for the same typeface. To Roman typeface, within the fields related to lettering, we can easily recognize that there are two main fonts: Feet (Serif) and Without feet (Sans-serif). In addition, the correlation between thick and thin strokes also affects the overall mood. Below are four common fonts.

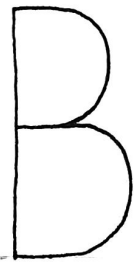

Type 1

Use single strokes (mono sketches) to create letter form. This form is often used for sketches or sub-elements in a drawing.



Type 2

To sans-serif, the stroke-width is created equal and can be changed depending on the artist's intention (If the width drops to the minimum, the text will return to type 1.)

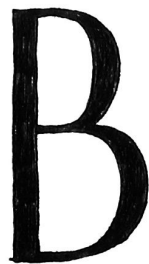

Type 3

Still sans-serif, but now the stroke-width is correlated to a different level. For example, horizontal strokes will be thinner than vertical ones, while left-side oblique strokes will be thinner than that of the right.

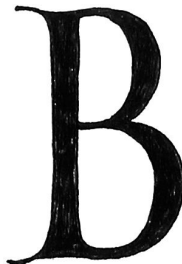

Type 4

To serif, the correlation between thick and thin strokes will be similar to type 3. However, as a typeface with legs, it creates a classic “vibe” and firmness for the drawing. (I often use this style as the main element.)

Also, there are other fonts that we can use. However, no matter which font, Roman letters always have a fixed structure that restricts change in general structure to ensure inherent harmony and balance.

Change the text structure

In the previous section, I suggested that we should not change the text structure too much. However, it doesn't mean that it can't be changed. The Roman structure and proportion have its own standards for visual harmony. We can refer to the Trajan script (on Trajan columns in Rome, Italy) to see the standard of beauty that Roman letters have been designed for. In case of changing, the aesthetic balance must be considered as priority.

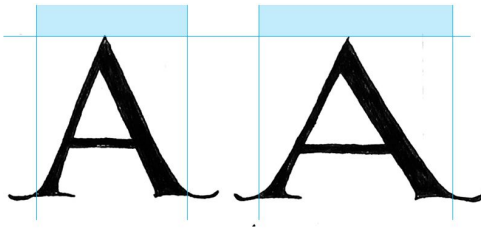

Change the width

The letter width can be changed to make it look strong and firm. However, my recommendation for maximum change is no greater than the letter height (that is, no more than 1:1).



Change the height

Changing the height is basically making the letter taller while keeping its width untouched. Similar to the above section, I prefer that the height does not exceed the horizontal-vertical ratio of 1:3.

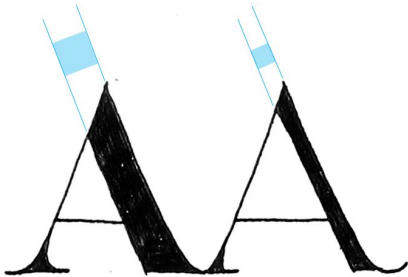

Change the correlation of the stroke

Letter correlation is the art of balancing stroke-width. Strokes can be created equal (type 2) or with contrast thickness. We can change this correlation, but avoid over-contrast (too thick or too thin strokes) making the content difficult to read.

Kerning/Letter spacing

Once finished formatting, balancing the space among letters in a word can help express the "spirit" of your artwork. In fact, although being more of a layout format, letter spacing also changes the way letters express themselves after formatting.

SPACING

SPACING

Choosing narrow or wide letter spacing will change the spirit of the entire drawing.

Customize details of the letter

This is a crucial part to completely change the personality of letters. One character has many parts and the customization of which is considered as adding, changing, or subtracting details for aesthetics improvements. Customizing letters can help us determine clearly the main and secondary elements of the layout or create ornaments for the drawing.

Each letter in the Roman manuscript has its own characteristics. However, if carefully analyzed, those letters can be grouped based on their shape and certain common properties. For example, the letter I, T and H contain vertical and horizontal strokes. O, D and Q have round and curved shapes. V, W and X are formed by oblique strokes. Therefore, instead of learning the variation of each letter, I will select typical traits and share how to apply them.

Straight strokes

Straight strokes appear in several letters, most of which are vertical intersecting horizontal lines.

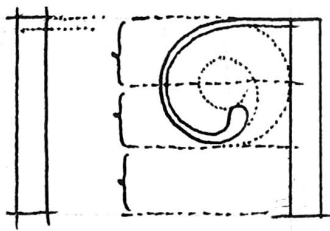

Type 1

Change the horizontal stroke intersecting vertical stroke with a radial curve. That curve is drawn next to the vertical stroke and has an adjustable magnitude.

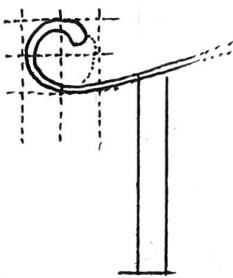

Type 2

Contrary to the first type, this curve will be drawn upwards, and the horizontal stroke will be angled to form a slant.

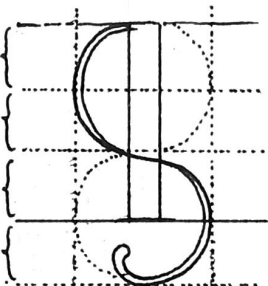

Type 3

As a combination of two circles with axes right in the vertical line, this customized stroke will have the same shape as the letter S. This type needs to be well-balanced to fit the letter.

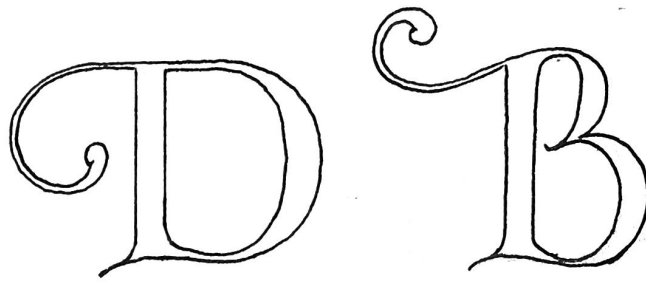

Some examples

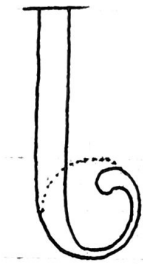

Type 4

For some letters with a single stroke, we can turn its tail, or even head, into a curve.

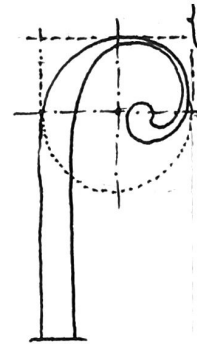

An example

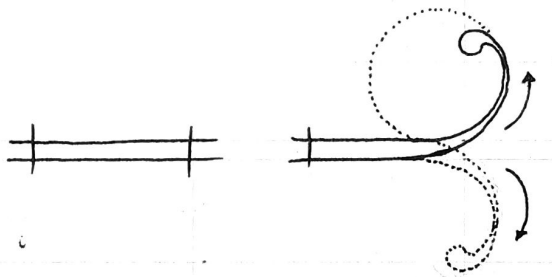

Type 5

Horizontal strokes can also be customized by adding curved details.

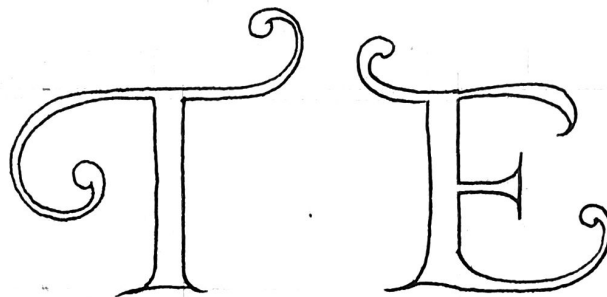

Some examples

Oblique strokes

As a part of some letters such as X, W, V, K and R, oblique strokes are created at the end or beginning, depending on each letter.

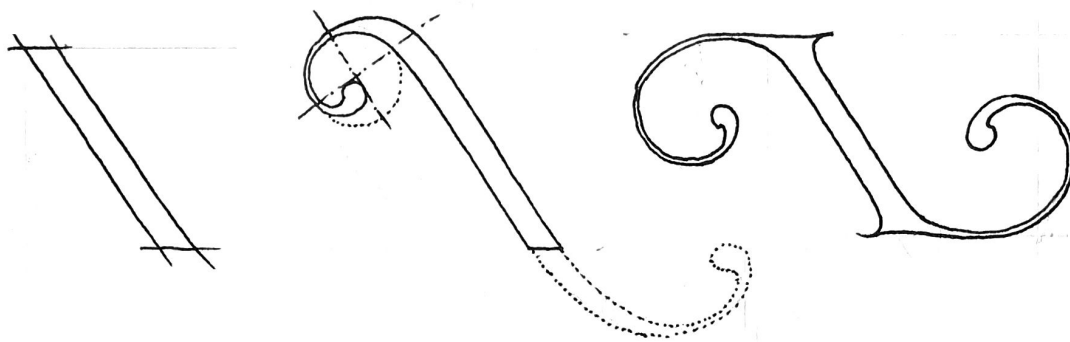

Basic slant

Customized slant

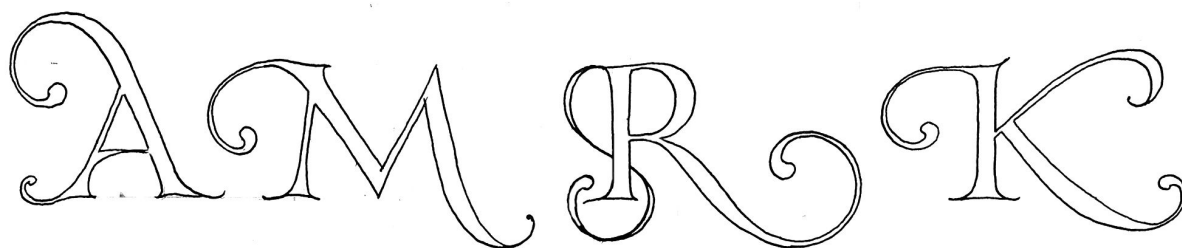

Some examples

The O stroke

This stroke appears in the O-shape letters. However, depending on each letter, it varies differently. Below are examples for the variations of the letter O and Q.

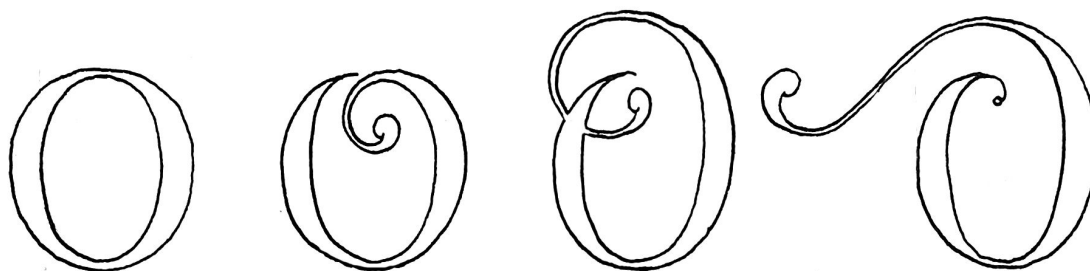

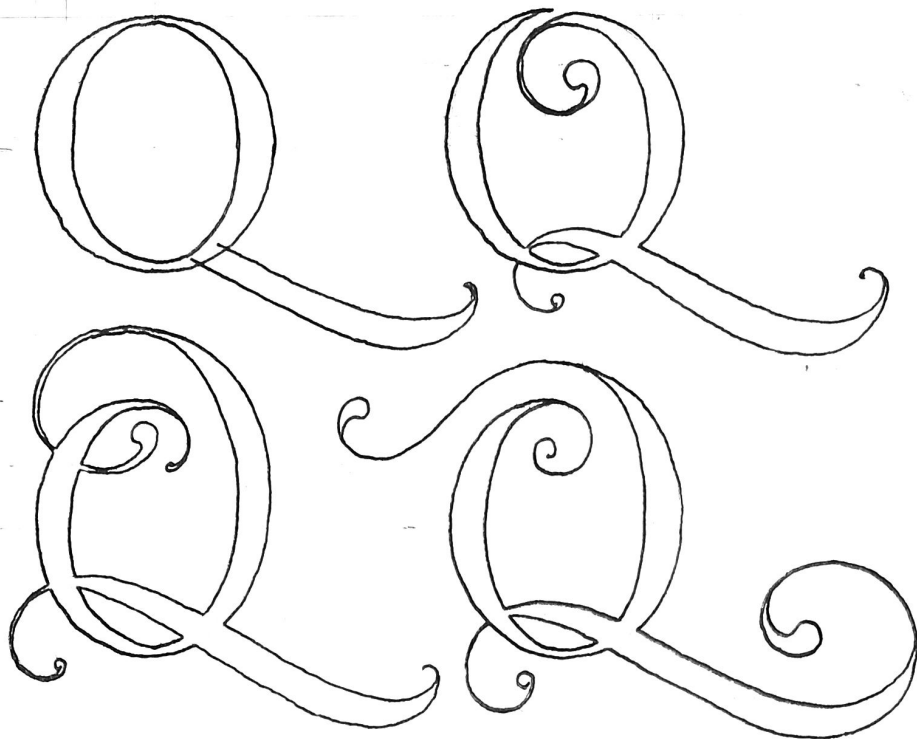

Some techniques to customize the letter Q

Additional part

In the additional section, we will learn how to customize the first part of letter C, G or S.

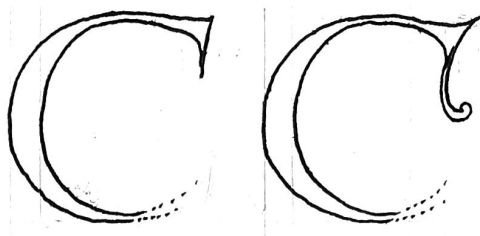

The beginning of those letters can be customized by linking it with a curved element. The picture below is an example of the variation of C and G.



The variation of the letter S

KUNDFESS

An example for a completed word variation

Drawing for reference

We have just completed the first step in the lettering process. In general, now we are able to do a complete drawing. Below is the example to reassess this process.

NATURE · NEVER · BREAKS · HER · OWN · LAW.

In the next sketch, I will use another quote of Da Vinci: *"Nature never breaks her own law"*.

· NATURE
· NEVER
· BREAKS
· HER · OWN
· LAW

Firstly, we will conduct line breaks based on the meaning and content of the sentence. Here, I separate Nature - Never - Breaks - Her own and Law. Remember to balance line spacing with letter height and length.

In general, we can see that all letter lengths have relatively harmonized with each other after line-breaking. However, to ensure the general spirit, I still need to divide the main-sub elements and plan to highlight the structure.

With the main-sub division, I will arrange 3 priority levels: 1, 2 and 3 for the ongoing content (As illustrated). The first prioritised elements are NATURE and LAW. The second is BREAKS, and finally, NEVER and HER OWN.

After sorting, the line spacing has been changed, so the next step is to balance that.

1 NATURE
3 NEVER
2 BREAKS
3 HER · OWN
1 LAW

NATURE
· NEVER ·
BREAKS
HER · OWN
LAW

Here is the manuscript with a balanced line spacing to ensure the aesthetics and visual harmony of the composition.

To highlight and embrace characteristics of the drawing, I choose to customize details of the letter.

The word Nature and Law are the two main elements. Therefore, I will decorate some parts of them with curved details.

In order to harmonize the layout within a fixed form, the B and S in the word Breaks are exaggerated.

NATURE
· NEVER ·
BREAKS
HER · OWN
LAW

NATURE
NEVER
BREAKS
HER · OWN
LAW

The completed sketch

For the next example, I will use the quote “The deeper the feeling, the greater the pain”. Unlike the previous sketch, in this example, I will transform the shape of the whole text to highlight the artwork even more.

THE · DEEPER · THE · FEELING · THE · GREATER · THE · PAIN
3 2 3 1 3 2 3 1

The first step is to separate main and secondary elements as well as create line breaks. With the above content, two prioritized words are FEELING and PAIN, followed by DEEPER and GREATER, and finally THE.

THE · DEEPER
 THE · FEELING
 THE · GREATER
 THE · PAIN

After line-breaking, the word THE seems to be repeated many times on the same side. Therefore, I will reposition and balance it with a square layout.

While dividing the position, I will change the shape of each part at will. The main parts of the shape will be bigger and more attractive. The position of the words THE will be divided equally and shrunk so that the layout can be kept in harmony.

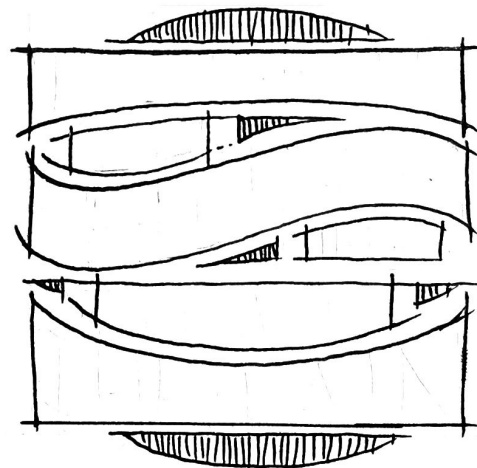

THE DEEPER
 THE FEELING
 THE GREATER
 THE PAIN

After line-breaking, the word THE seems to be repeated many times on the same side. Therefore, I will reposition and balance it with a square layout.

After layouting and arranging the letters, I will customize them.

THE DEEPER
THE FEELING
THE GREATER
THE PAIN

4. DETAILS & ORNAMENTS

Ornaments and other details can embrace the drawing greatly. Simple strokes or complex ornaments can both change the way the drawing looks. In this section, I will introduce some of my favorite techniques and templates.

Single strokes

A simple underline can also highlight letters. Single strokes can be customized depending on the stroke-width or the number of strokes that can be combined.

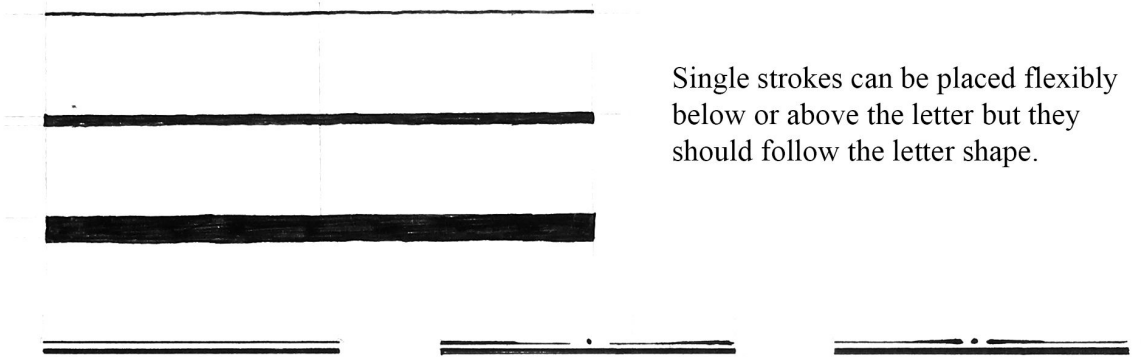

Combine single strokes



Besides basic single-strokes, we can also use ornaments to “dramatise” the letter. Let's have a quick look at some following examples.



To have a more intuitive look, I have created some ornaments from simple to complex level. They can be applied to both the upper and lower part of the letter.

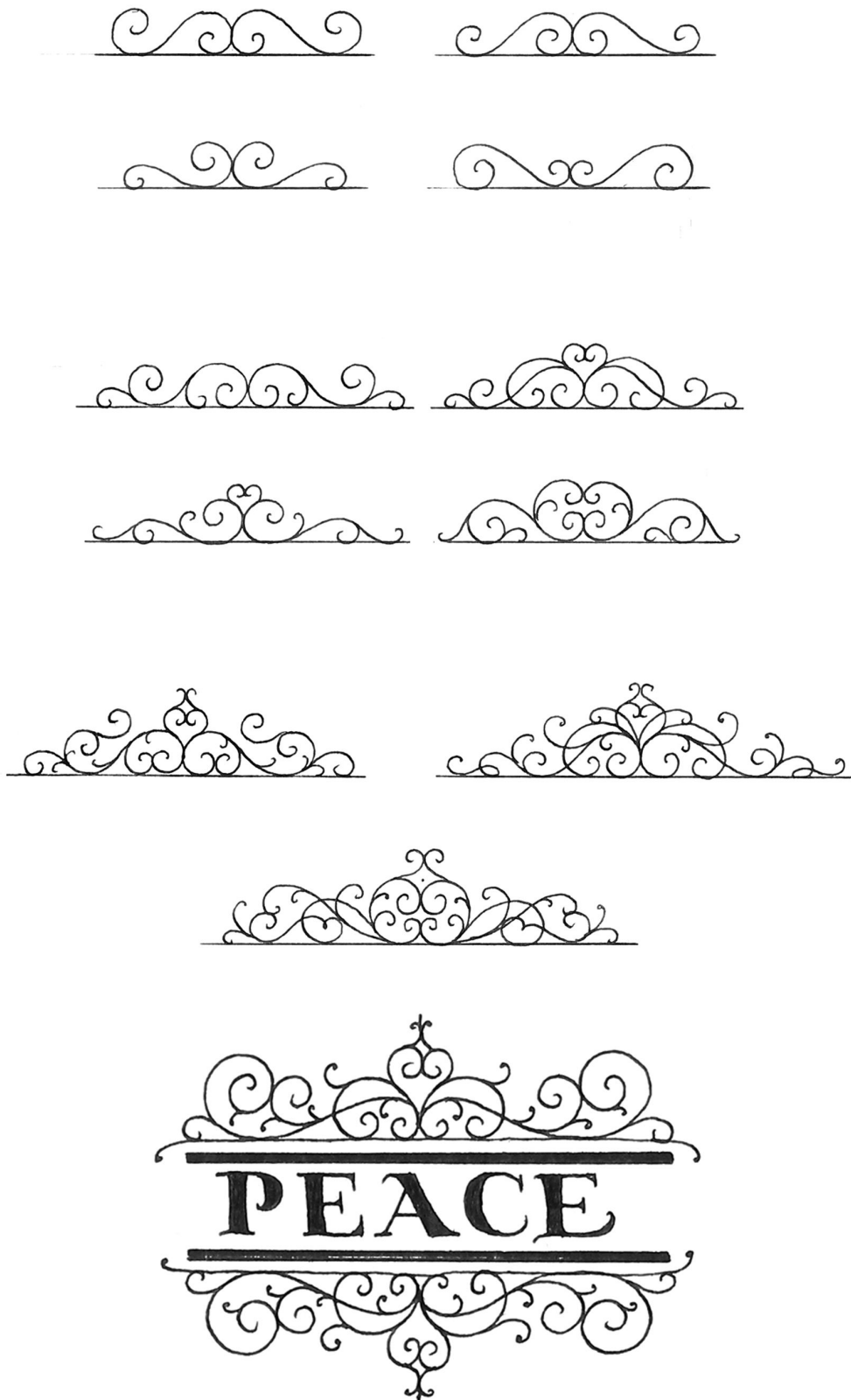

Banner

When it comes to Lettering, Banner is a can't-be-missed element. Banners are commonly known as ribbons used for a variety of purposes, including decoration. For Lettering, Banner can effectively highlight text content as well as create an embossing effect for the whole drawing.

There are many Banner-drawing techniques, from simple thin lines, realistic description to Scratchboard Illustration. Each has its own strengths and usage depending on the nature theme of the content.

Single-stroke banner

This is the most basic form of banner created by single strokes. With two parallel curves or ripples, we have made the basic shape of a banner.



This kind of banner can be customized in a similar way with the single-stroke decorative letter mentioned earlier.

Banner with single-stroke ornaments

Now, single strokes are created as ornaments to enhance the aesthetics for the banner.

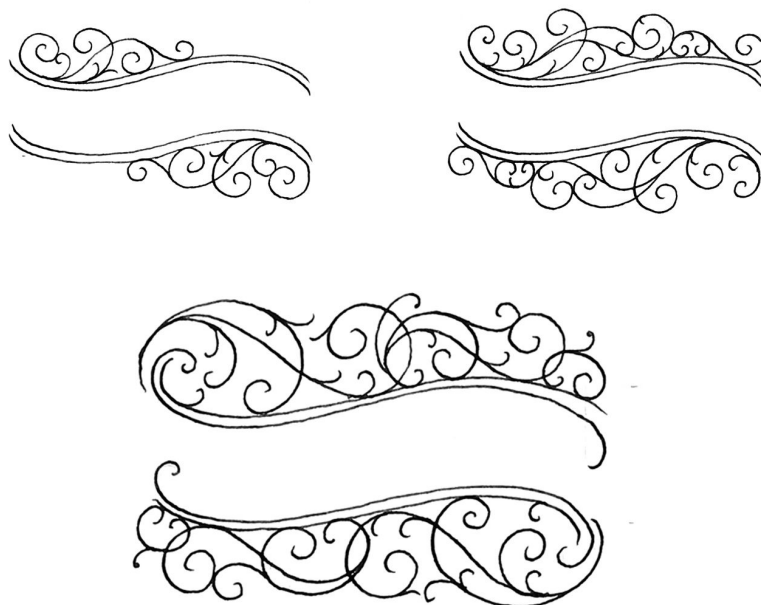

Banner with frame

Framed banners are those with a closed, seamless form of a ribbon shape. Depending on which technique used, the banner can be embossed.

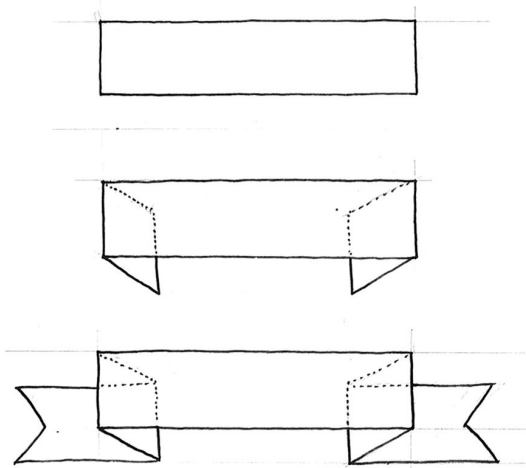

The most basic form of a framed banner is straight. Let's imagine that Banner is like a piece of paper to create, visualize and form it with a certain shape.

In the basic form, the piece of paper will be folded at two ends as illustrated. Meanwhile, the end of the banner can be cut into squares or made double tails as in the below image.

Technically, the curved banner as illustrated is no different from the straight banner. However, one notable factor is that its two sides will be bent instead of folded.

Please note the dotted details (the invisible parts) and smoothly-bending corners. Those things need to be drawn according to the actual graphic to create the logic for the banner.

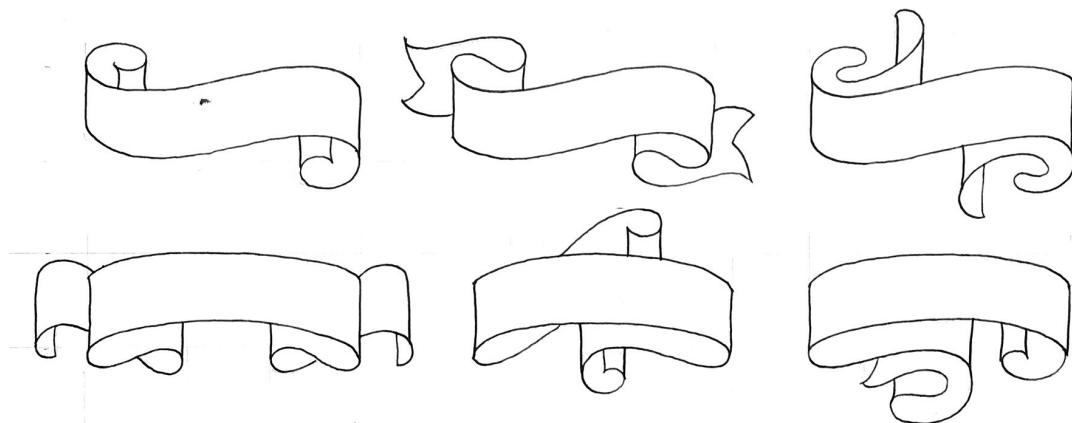
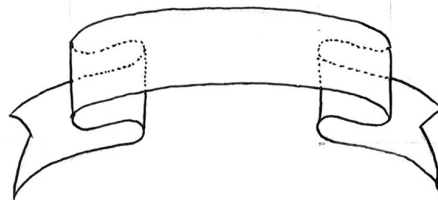

Some banners for reference

Drawing banner details

After creating an external form and shape for the banner, we can design extra details to fit personal intention. Sometimes, banners can be used in simple form, and by adding more details, we highlight the letter better.

Here are some types of detail drawings.

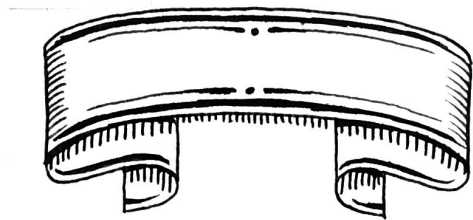

Type 1: Creating strokes

Similar to the single-stroke technique mentioned in the previous section, banners can also be decorated with single strokes.

With basic techniques, single strokes are created on the top and bottom edges of the Banner. Then, at the curved corners or the lower overlapping part, parallel strokes will be created to “contour” the drawing.

Type 2: Dark background

This is a common technique that uses value-inversion. Now, the banner background will be darkened for the text to stand out with the light or opposite color.

With this technique, usually, we will draw the details of the Banner in a simple and not too realistic way.

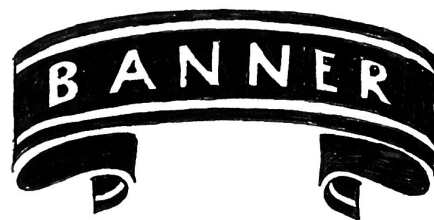

Type 3: Realistic style

The realistic depiction requires graphic techniques. It means that if we are not used to this kind of drawing, practising frequently will help you master it.

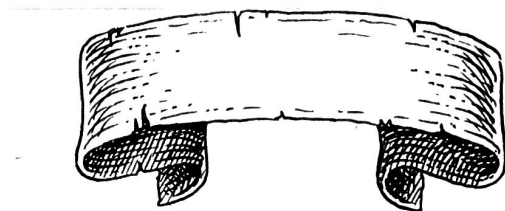

The details on the banner will be realistically depicted by strokes and colors to create a realistic shape. At the same time, we should also pay attention to details on the surface or the materials used.

Type 4: Scratchboard Illustration

At first glance, this method may look simpler than the realistic depiction. In fact, it can only be implemented after understanding and mastering the realistic depiction.

The parallel strokes of the Scratchboard have different widths which create the light-dark correlation on the banner surface, contributing to the whole shape and structure.

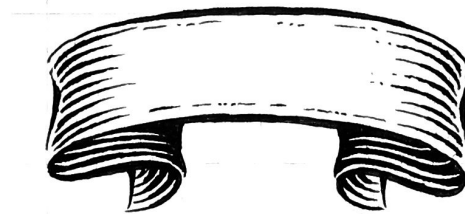

Some banners for reference

Below are some banners made for your reference. The dotted lines show the movement of the banner.

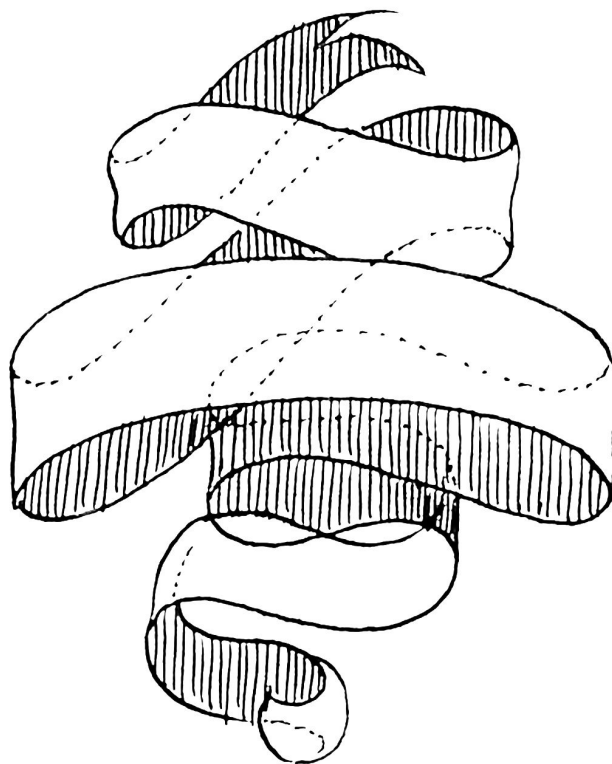
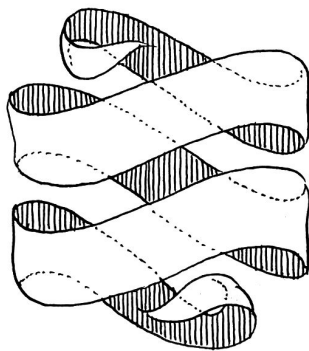
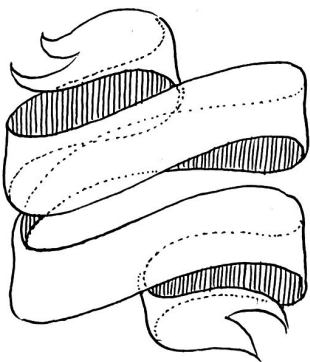

Sample drawing

We have gone through all of the most fundamental elements in lettering with short content. To have the most objective view, I will step by step create a sample drawing with the famous quote "Learning never exhausts the mind" from Da Vinci.

'LEARNING · NEVER · EXHAUSTS · THE · MIND' - *Da Vinci*

As usual, detecting a sentence break as well as the main-secondary priority is the first thing to do. Based on the meaning of the sentence, in general, I will choose three words Learning, Exhausts and The Mind to be the main elements. However, the spotlight is on the word Exhausts, while Never will be moderated.

On the right, this is a sketch of the primary-secondary priority as well as an overview of the letter magnitude and correlation.

2 LEARNING
3 NEVER
1 EXHAUSTS
2 THE · MIND

Having a typeface, I will design and sketch three different layouts for better evaluation and consideration.

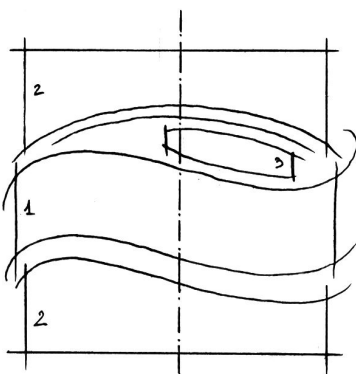

Layout 1 uses an even shape with the center Banner highlighted. The rest of the design will be framed based on that banner, and linked together to form the overall shape.

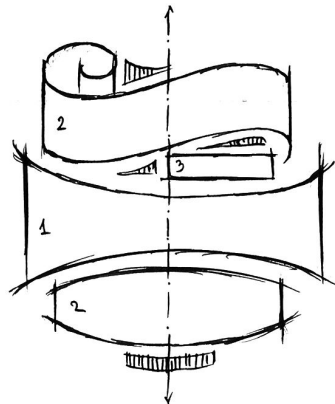

Layout 2 uses a free-form shape, in which the banner is drawn in the upper part. In the center, there is a letter shape bent on both sides. The last shape has its edge bend on the opposite side to the center shape.

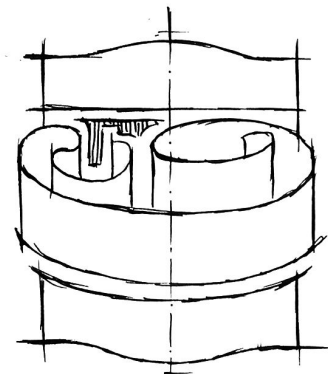

Layout 3 is designed with the banner stands in the middle. Now, its shape will be more complicated than that of layout 1. The other two shapes will be bent according to the main banner's shape to reduce the order of priority.

Layout 1

Advantage: A solid, firm, safe-to-handle shape with secondary elements are harmoniously created.

Disadvantage: Easy to get boring because less-priority elements like the word Learning and The Mind are easy to dominate Exhausts.

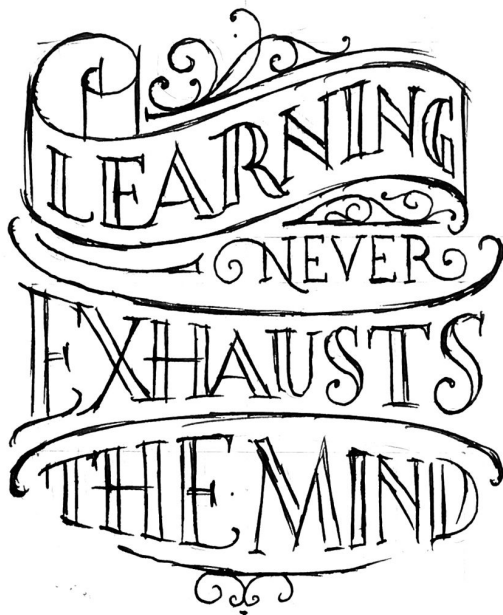
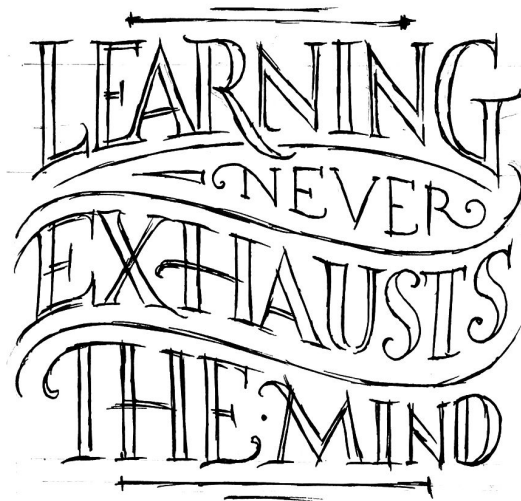

Layout 2

Advantage: Layout 1 is more impressive thanks to its details and shapes.

Disadvantage: The word Learning can overpower most of the layout, making the drawing heavier at the top.

Layout 3

Advantage: The main elements will be arranged properly with the original intention. Also, details are better highlighted and look more attractive.

Disadvantage: Layout and details can easily get tangled during the drawing process.

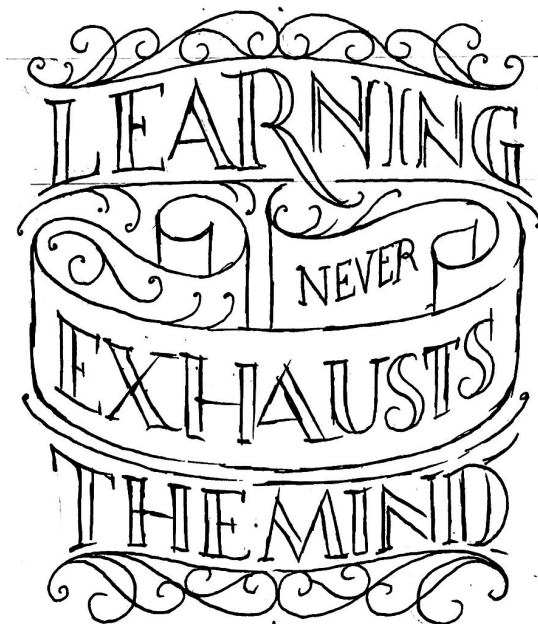

After considering all three layouts, I choose the last one and complete the drawing below with Scratchboard Illustration technique.

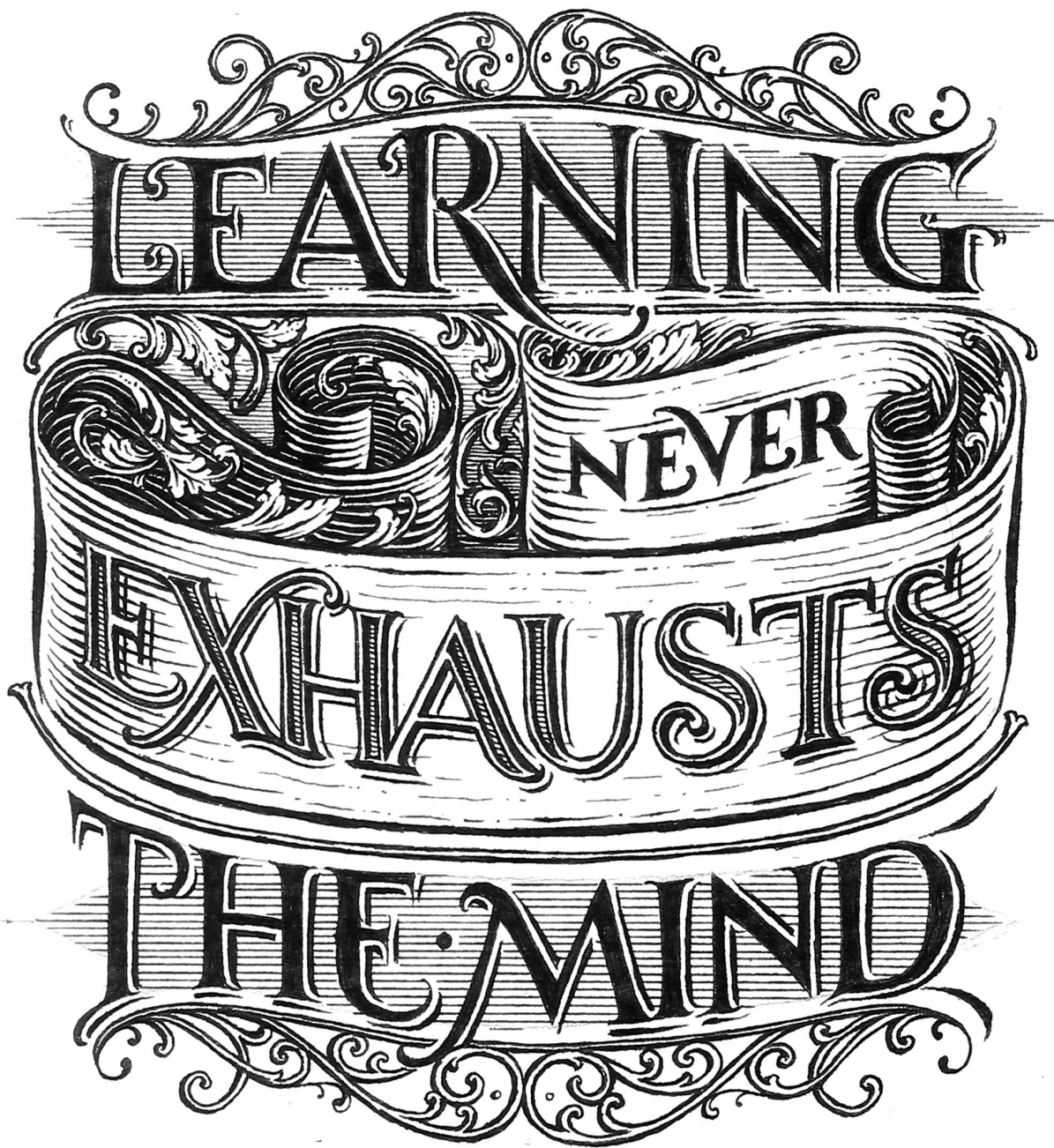

Drawing details of the letter

The letter is the most important part of a drawing and can be customized in many ways. In text-drawing techniques, creating details such as shades, blocks and textures are the factors that determine most features of a design.

Shading

Shading is a very popular lettering method. Under a variety of shading techniques, the text is embossed to stand out.



Technique 1: Draw a single stroke at the angle of 45° to the lower-right or upper-left corner of the word. This stroke is kept at a certain distance from the word.



Technique 2: Similar to the first technique, but the shade is a block instead of a single stroke. This block is still separated from the main part of the text.



Technique 3: A shade is drawn with parallel strokes and linked to the letter as illustrated.



Technique 4: Overlapping layers, with the first layer is contouring and the next one shading. The shading directions are all at 45° .



Technique 5: At first, this form may look similar to the second technique. However, the shade has its edges not following the light direction, but rather similar to the shape of the stroke.

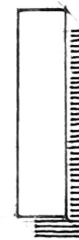

Technique 6: Similar to technique 3. However, the strokes are created horizontally, and the shading block is separated from the shape of the letter.

Details inside the letter

Shading can be done on the outside so that the inside details will create embossing blocks for the letter shape.



Technique 1: Create a white border by overlaying its inside part with dark color. Note, the border should not be 1/3 thicker than the stroke.



Technique 2: Similar to technique 1. However, the inside will not be fully covered, but horizontally drawn. And at the same time, shade the edge.



Technique 3: Similar to mentioned techniques, but the one-sided border will be moderated.



Technique 4: The text borders are embossed by shading one side of the border. Now, the inside of the text can be drawn freely.



Technique 5: In addition to the determined border, the inside of the letter will be decorated with single-stroke details or other ornaments (freely.)



Technique 6: The border of the stroke will be drawn with dots, and we will also create a shade for it inside the letter.

mboss the letter

As its "temporary" name has implied, Embossing is the method of dividing blocks, creating shades, or adding ornaments in a suitable way. Below is what I often use to create embossing structures for the letters.

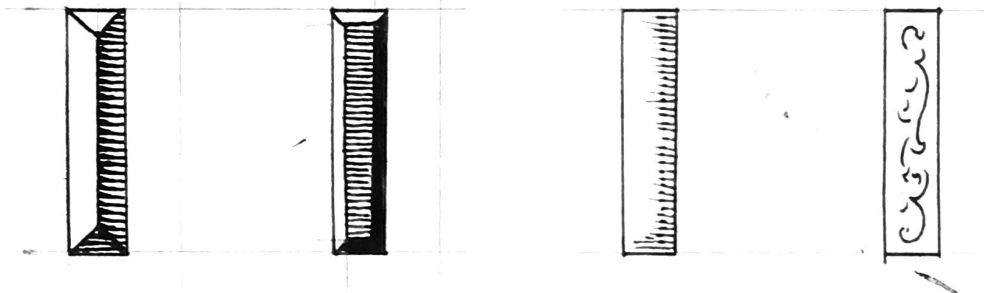

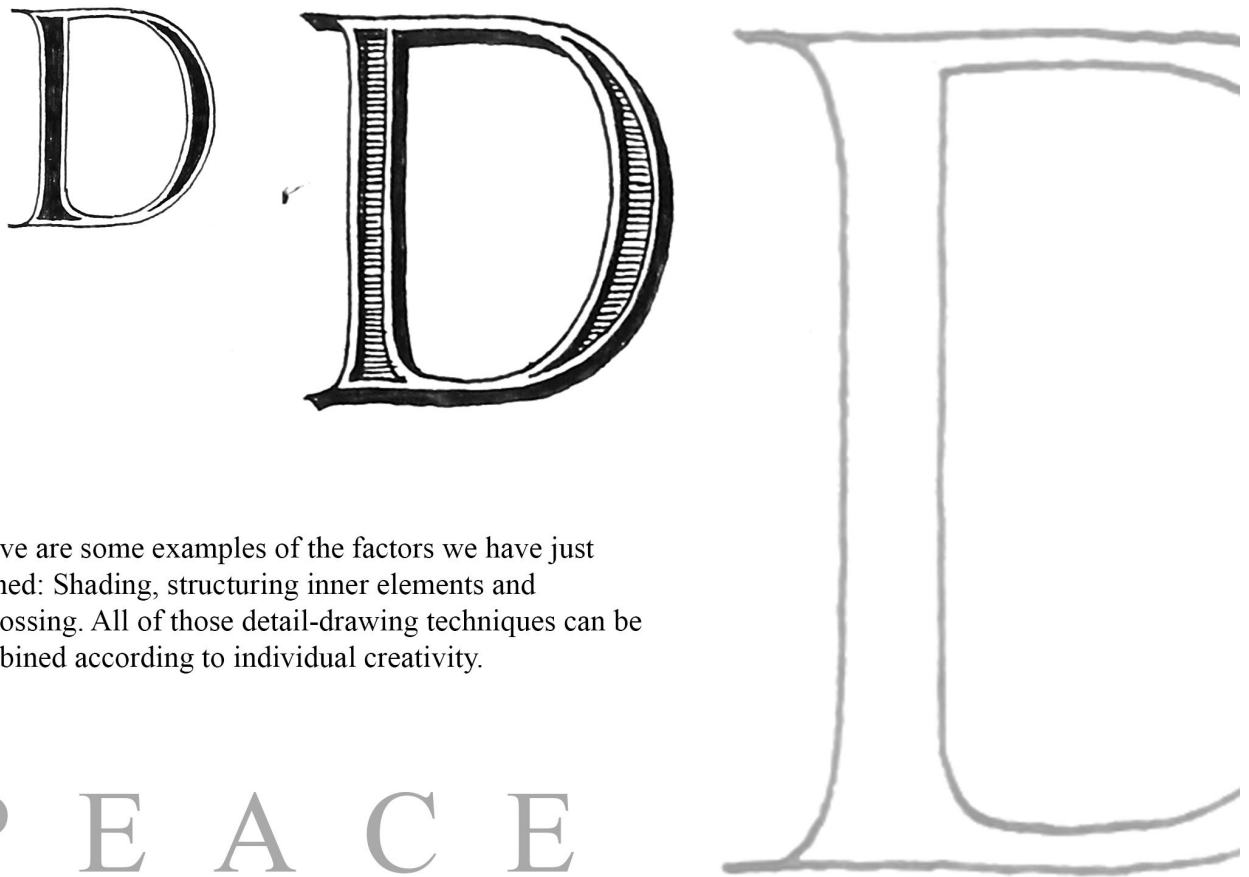
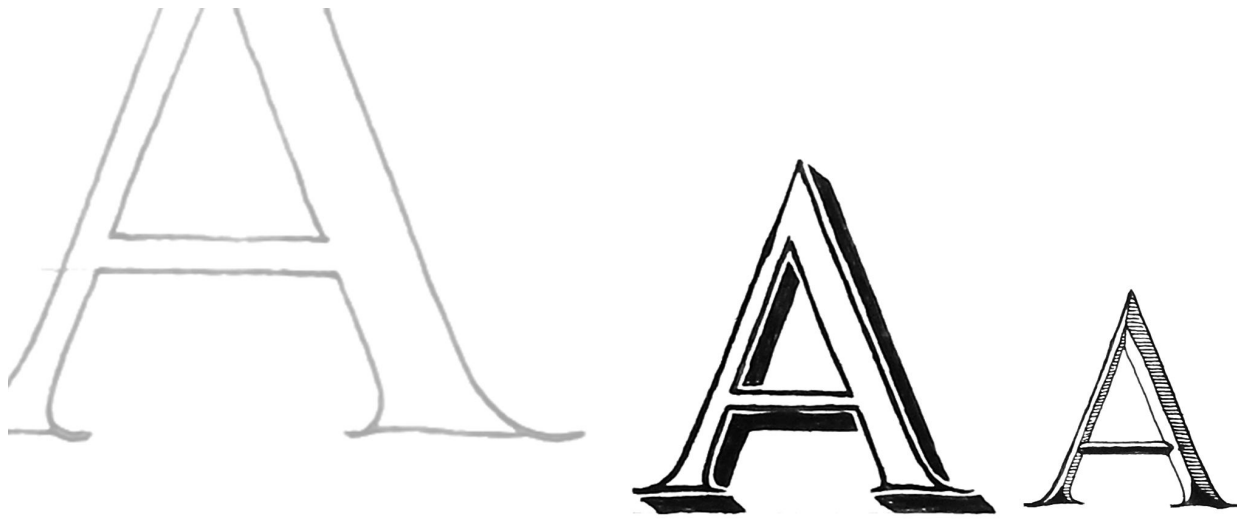

Above are some examples of the factors we have just learned: Shading, structuring inner elements and embossing. All of those detail-drawing techniques can be combined according to individual creativity.

P E A C E



Example for customized and detailed text drawings

Steps to draw details of the text (Sample for reference)

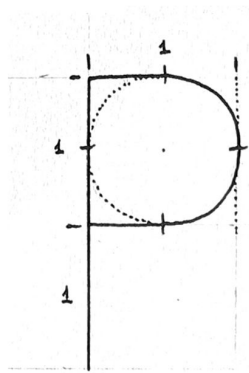

Step 1: Divide the proportions and parts of the text with single strokes. The proportion of letters can be customized according to each individual.

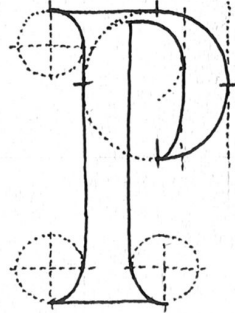

Step 2: Based on the proportions created in step 1, draw a basic shape for the text (You can choose Serif or Sans serif) with customized thickness and correlation.

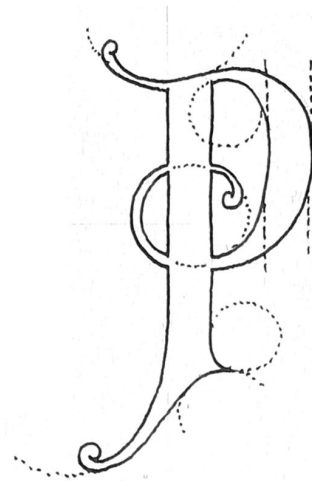

Step 3: Customize text shape with the method learned in the previous section.

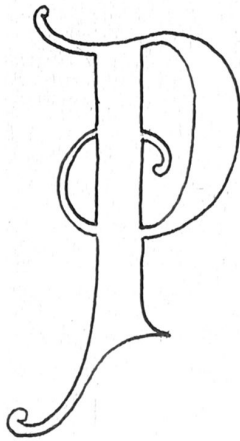

Step 4: Complete the shape with a single-stroke outline.

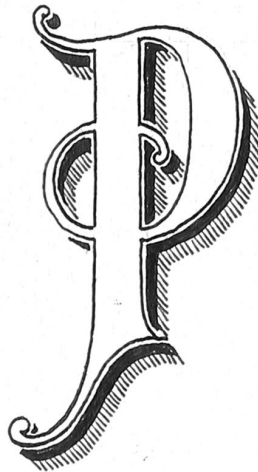

Step 5: Shade the letter shape. In this example, I use an over-layer shading technique.



Step 6: Decorate the inside of the letter with details. Finish.

Some sample layouts for reference

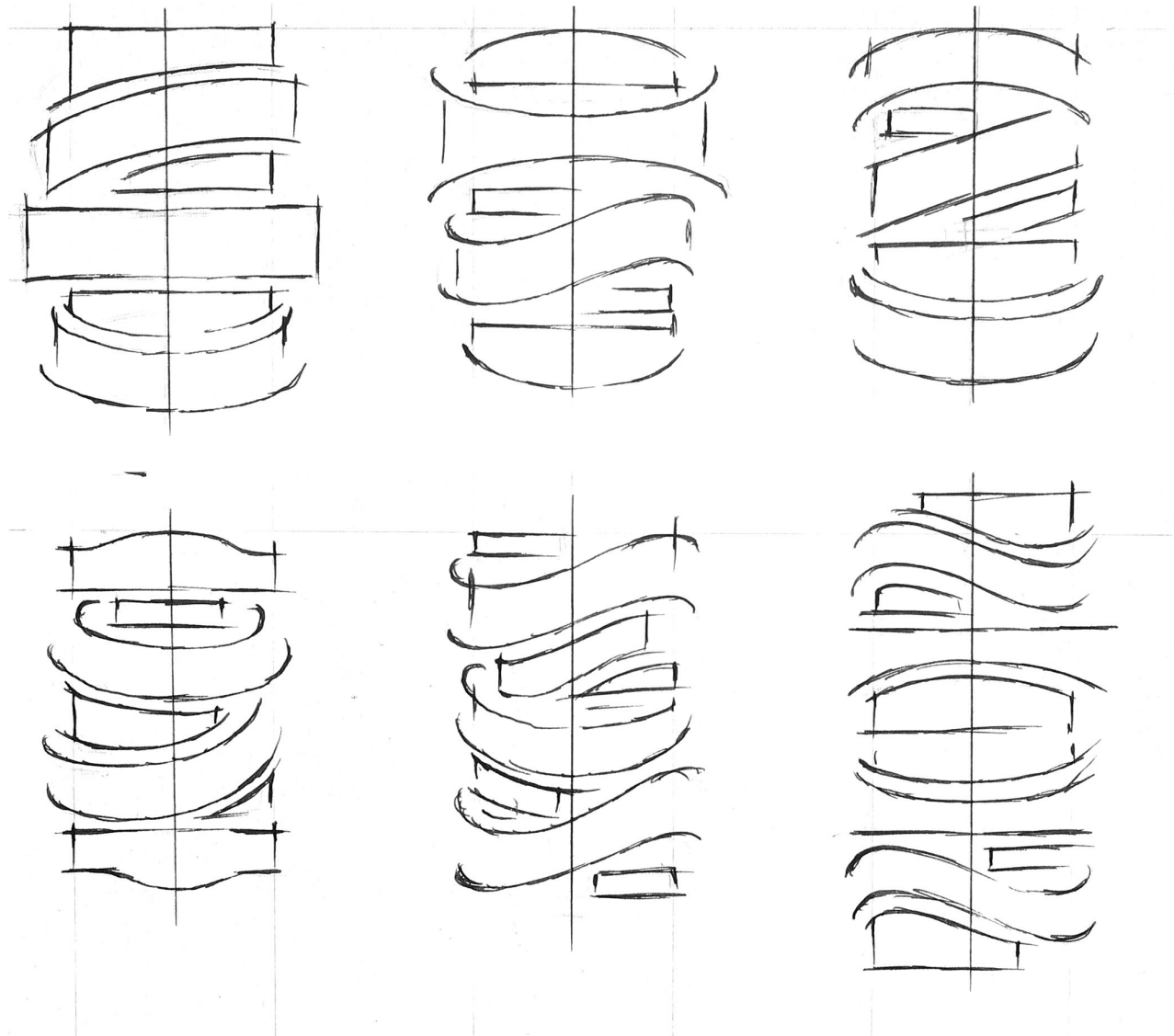

Summary

We have gone through Lettering design for short content with the most commonly-used and foundational techniques. Practicing and referring to different styles of drawings will reinforce and empower your experiences related to this technique.

Within my experience, I have some suggestions regarding Lettering in general. Although most of us are inspired by highly-detailed and intricate drawings, no matter how complex a drawing is, it all comes from a simple frame. Therefore, practicing basic shapes, utilizing moderate techniques, dividing the main-sub elements and structuring appropriate content are the most important factors.