

INDEX

1345 - 1356

<i>INTRODUCTION 1345</i>	3
<i>TROUBLE SHOOTING</i>	4
<i>DISASSEMBLY</i>	8
<i>ASSEMBLY</i>	15
<i>PARTS</i>	24
<i>INTRODUCTION 1356</i>	28
<i>TROUBLE SHOOTING</i>	30
<i>DISASSEMBLY</i>	35
<i>ASSEMBLY</i>	45
<i>PARTS</i>	58



Technical Service Information

INTRODUCTION

WARNER GEAR

1345 - 1356

With more 4 wheel drive vehicles coming into our shops, the need for information on transfer cases has increased. Mike Weinberg of Rockland Standard Gear has gathered information on various types and model transfer cases that are most common. This series of booklets cover the general information, operation, tear down, and assembly of these units. And in most cases a parts breakdown is shown which helps in ordering replacement parts.

We thank Warner Gear for the information and illustrations that made this booklet possible

ROBERT D. CHERRNAY
TECHNICAL DIRECTOR

DALE ENGLAND
FIELD SERVICE CONSULTANT

FRANK MIETUS
TECHNICAL CONSULTANT

WAYNE COLONNA
TECHNICAL CONSULTANT

WELDON BARNETT
TECHNICAL CONSULTANT

ED KRUSE
LAYOUT

AUTOMATIC TRANSMISSION SERVICE GROUP
9200 SOUTH DADELAND BLVD.
SUITE 720
MIAMI, FLORIDA 33156
(305) 661-4161

1356

On-Vehicle Service and Troubleshooting

2-1. MAINTENANCE

2-2. GENERAL. The only periodic maintenance required for the Borg-Warner Automotive 13-45 transfer case is to maintain proper lubrication.

2-3. LUBRICATION SCHEDULE. Refer to Table 2-1.

2-4. APPROVED LUBRICANT. Use only automatic transmission fluid, Dexron® II, XT-2-QDX (Ford ESP-M2C138-CJ) or equivalent in the transfer case.

NOTE: To check or drain the lubricant, the transfer case should be warm. This is best done shortly after shutdown.

2-5. CHECKING LUBRICANT LEVEL

CAUTION

Do not use an impact wrench to remove or install fill or drain plugs since this will damage female threads in transfer case cover.

- a. Wipe fluid level plug (see figure 2-1) and surrounding area clean.
- b. Remove fluid level plug.
- c. When transfer case is full, lubricant will just drip out fluid level plug opening.
- d. Add approved lubricant (refer to paragraph 2-4) if required.
- e. Install fluid level plug and torque to 14-22 lb-ft (19-30 Nm).

Table 2-1. Lubrication Schedule

FREQUENCY	PROCEDURE
With each engine oil change Yearly or after every 30,000 miles, whichever comes first	Check transfer case lubricant level Change transfer case lubricant

2-6. CHANGING LUBRICANT

- a. Wipe fluid level and drain plugs (see figure 2-1) and surrounding areas clean.
- b. Place suitable container under transfer case. Transfer case holds approximately 6.0 US pints when full.
- c. Remove drain plug.
- d. Remove fluid level plug.
- e. Allow all lubricant to drain.
- f. Install drain plug and torque to 14-22 lb-ft (19-30 Nm).
- g. Add approved lubricant through fluid level plug opening until lubricant just begins to drip back out of opening.
- h. Install fluid level plug and torque to 14-22 lb-ft (19-30 Nm).

2-7. TROUBLESHOOTING

2-8. GENERAL. In the event of operating difficulty, it is recommended that the transfer case (engine) be shut down. In most cases, to accurately pinpoint the source of trouble, it may be necessary to remove and disassemble, or partially disassemble, the transfer case. Specific inspection procedures for detail parts of the transfer case are provided in Section 4.

2-9. TROUBLESHOOTING CHART. Table 2-2 lists troubles which may be encountered along with possible causes and remedies.

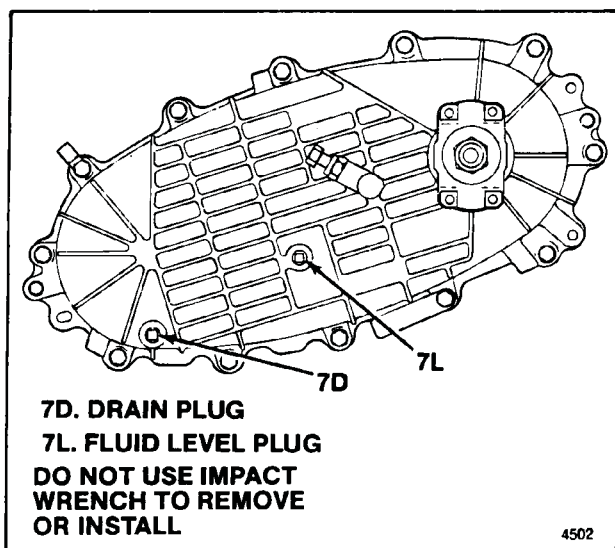

Figure 2-1. Drain and Fluid Level Plugs

Table 2-2. Troubleshooting Chart

TROUBLE	POSSIBLE CAUSE	REMEDY
Will not shift (control lever moves)	Control lever or shift linkage broken or damaged Damaged shift cam; broken shift fork	Replace damaged parts Remove transfer case cover and check for damaged parts. Replace damaged parts
Hard shift or control lever will not move into position	Improper operation Improper or low transfer case lubricant Shift fork binding Binding of sliding shift hub, collar or gears	Refer to vehicle operator's manual for specific operating sequence, if any Add or drain and replace with proper lubricant (refer to paragraph 2-4) Remove transfer case cover and check for damaged parts. Replace damaged parts Remove transfer case cover, reach down into transfer case and check that sliding parts (parts with shifting grooves) slide freely on shaft. Remove and replace damaged parts
Transfer case jumps out of engagement	Damaged shift linkage Internal shift parts damaged or excessively worn Shifting fork loose on rail or damaged	Repair shift linkage Disassemble and check for worn or damaged parts. Replace damaged parts Disassemble and check for wear or damage. Replace worn or damaged parts
Transfer case locked in one position	Damaged shift linkage Fork loose on rail Worn or damaged fork Worn or damaged shift cam, hub or collar Worn or damaged gears	Repair shift linkage Remove transfer case cover and check for loose fork on rail. Replace parts as required. Remove transfer case cover and check for wear or damage. Replace damaged parts Disassemble and check for worn or damaged parts. Replace worn or damaged parts Disassemble and check for worn or damaged gears. Replace worn or damaged gears
No front wheel drive with control in four wheel drive	Broken drive chain	Disassemble, check all internal parts for damage, replace drive chain

Table 2-2. Troubleshooting Chart

TROUBLE	POSSIBLE CAUSE	REMEDY
Transfer case noise in all modes of operation. NOTE: Make sure noise is coming from transfer case and not clutch, transmission, drive shaft or other components	Improper or low transfer case lubricant Loose bolts or other attaching parts Noisy transfer case bearings Noisy gears	Add or drain and replace with proper lubricant (refer to paragraph 2-4) Make sure all attaching parts are torqued to specifications Disassemble and check bearings and parts in and on which they operate for wear or damage. Replace worn or damaged parts Disassemble and check for worn or damaged parts (including speedometer gear). Replace worn or damaged parts
Transfer case noise in 4WH or 4WL	Worn or damaged sprockets or drive chain Incorrect tire pressure	Disassemble and check for worn or damaged parts and replace as required Inflate all tires to manual specifications
Transfer case leakage	Cracked case Leakage from other components Breather clogged Too much or improper lubricant Loose bolts at sealing faces Improperly applied sealant Worn or damaged oil seal	Replace case Verify transfer case leakage. Thoroughly clean, operate and check for leaks Remove breather hose and breather and clean or replace Remove fluid level plug to check for excess, or drain and replace Torque bolts to specifications Replace and torque bolts to specifications Replace oil seal

2-10. REMOVAL AND INSTALLATION

2-11. REMOVAL OF TRANSFER CASE. Refer to the vehicle service manual for specific instructions regarding supports, skid plates, shift linkage, speedometer cable and other components related to the transfer case installation. These may need to be removed to provide access to the transfer case. A suitable hoist for the vehicle and a jack or stand for the transfer case will be required. The jack or stand must be capable of completely and independently supporting the transfer case. It also must be able to lower, raise and move the transfer case laterally. Proceed as follows (see figure 2-2):

a. Position vehicle over suitable hoist.

- b. Disconnect negative battery terminal.
- c. Shift transmission into park or neutral. Move 4WD control lever into 4H detent.
- d. Lift vehicle.
- e. Place drain pan under transfer case and remove transfer case drain and fluid level plugs (see figure 2-1). Drain all fluid from transfer case and re-install plugs.
- f. Disconnect wiring from 4WD switch on transfer case cover (16).
- g. Disconnect shift linkage from transfer case shift lever (47).
- h. Disconnect speedometer cable from transfer case cover (16).

- i. Disconnect breather hose from breather barb (85) on transfer case.
- j. Disconnect front driveshaft from transfer case front output yoke (83).
- k. Disconnect rear driveshaft from transfer case rear output yoke (4).
- l. Support transfer case with suitable jack or stand.

CAUTION

Make sure transfer case is completely supported by jack or stand before removing bolts (101) attaching transfer case to transmission. Do not allow transfer case to "hang" from transmission through splined shafts or damage may result.

- m. Remove bolts six (101) attaching transfer case to transmission adapter.
- n. Move transfer case straight back to completely disengage spline of transfer case input shaft (63) from transmission.
- o. Carefully lower transfer case on jack or stand.
- p. Remove gasket (103) used between transmission and transfer case.

2-12. INSTALLATION OF TRANSFER CASE.

Refer to the vehicle service manual for specific instructions regarding supports, skid plates, shift linkage, speedometer cable and other components which were removed to provide access to transfer case. With vehicle on hoist and transfer case on a suitable jack or stand, proceed as follows (see figure 2-2):

- a. Apply thin coat of high temperature grease to spline of transmission output shaft.
- b. Install new gasket (103) on mounting face of transfer case.
- c. Raise transfer case on jack or stand and align with transmission.

CAUTION

Make sure transfer case is in exact alignment with transmission before engaging splines. Do not force transfer case onto transmission. Otherwise, damage may result. If necessary, turn output shaft of transfer case to align input shaft (63) spline with that on transmission.

- d. Carefully move transfer case forward, engaging spline on transmission and dowel pin, until mounting face of transfer case (93), gasket (103) and transmission adapter (102) are in contact.
- e. Make sure mounting holes in transfer case (93), gasket (103) and transmission adapter (102) are aligned and install six mounting bolts (101). Torque mounting bolts to 25-43 lb-ft (34-58 Nm).
- f. Connect rear driveshaft to transfer case rear output yoke (4).
- g. Connect front driveshaft to transfer case front output yoke (83).
- h. Connect breather hose to breather barb (85) on transfer case.
- i. Connect speedometer cable at transfer case rear cover (16).

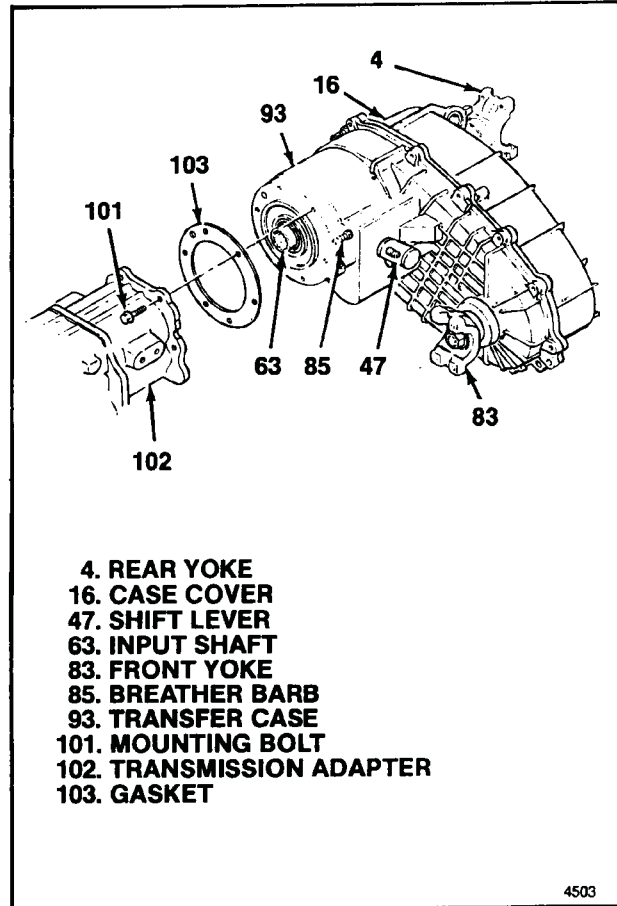

Figure 2-2. Transfer Case Installation

- j. Connect shift linkage to transfer case shift lever (47).
- k. Connect wiring to 4WD switch in transfer case rear cover (16).
- l. Fill transfer case with approved lubricant as described in paragraph 2-1.

CAUTION

Failure to fill transfer case to proper level with approved lubricant will result in damage when engine is started.

NOTE

Use of pump type filler may be necessary when filling transfer case installed on vehicle.

NOTE

If transfer case has been removed for repair or overhaul, there will be no lubricant in upper cavities served by transfer case pump. Lubricant level at fluid level plug opening will not be accurate until pump is operated and these cavities are filled. This can be done on hoist if wheels are free or by driving. Recheck lubricant level after operating pump.

- m. After final check of lubricant level, lower vehicle and connect negative battery terminal.

Disassembly

3-1 GENERAL INFORMATION

3-2. During disassembly, refer to the illustrations provided with the text. In addition, an exploded view of the complete assembly can be seen in Section P, Parts.

3-3. This section provides instructions for complete disassembly of the transfer case as would be required for overhaul. If the transfer case is not due for overhaul, and repair affecting specific parts is required, disassemble only to the extent necessary to gain access to these parts. Parts removed from the transfer case as subassemblies or groups need not be disassembled for repair unless they contain the affected parts

3-4. REMOVAL AND INSTALLATION OF TRANSFER CASE

3-5. Refer to paragraph 2-10.

3-6. TRANSFER CASE DISASSEMBLY

3-7. **REMOVAL OF REAR YOKE GROUP.** Position transfer case on work bench with cover and rear or upper yoke side up. Use wooden blocks under front or lower yoke to keep assembly level. Proceed as follows (see figure 3-1):

- a. Remove nut (1) and washer (2).
- b. Pull yoke (4) and remove oil seal (3).
- c. Pull oil seal (5).

3-8. **REMOVAL OF COVER.** Proceed as follows (see figure 3-2):

- a. Remove 4WD switch (6) and two plugs (7).

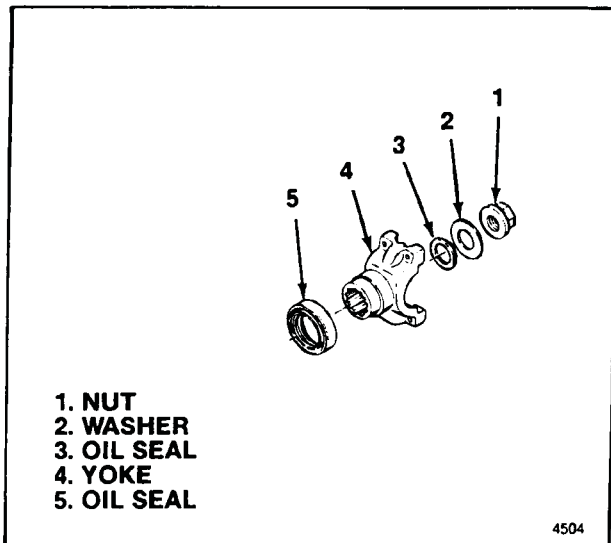

Figure 3-1. Rear Yoke Group

b. If difficulty is encountered in removing speedo gear (8), wait until after cover assembly (12) is removed.

c. Remove twelve bolts (9). This will free wire clips (10) and identification tag (11). Use care not to lose identification tag. It contains information required for ordering replacement parts.

d. Pry at the bosses provided on the cover (16) and transfer case (93) to break the sealant bond loose. Then, lift the cover assembly (12) straight up to remove.

e. Pull needle bearing (13) from cover (16).

f. Remove snap ring (14) and pull ball bearing (15) from cover (16).

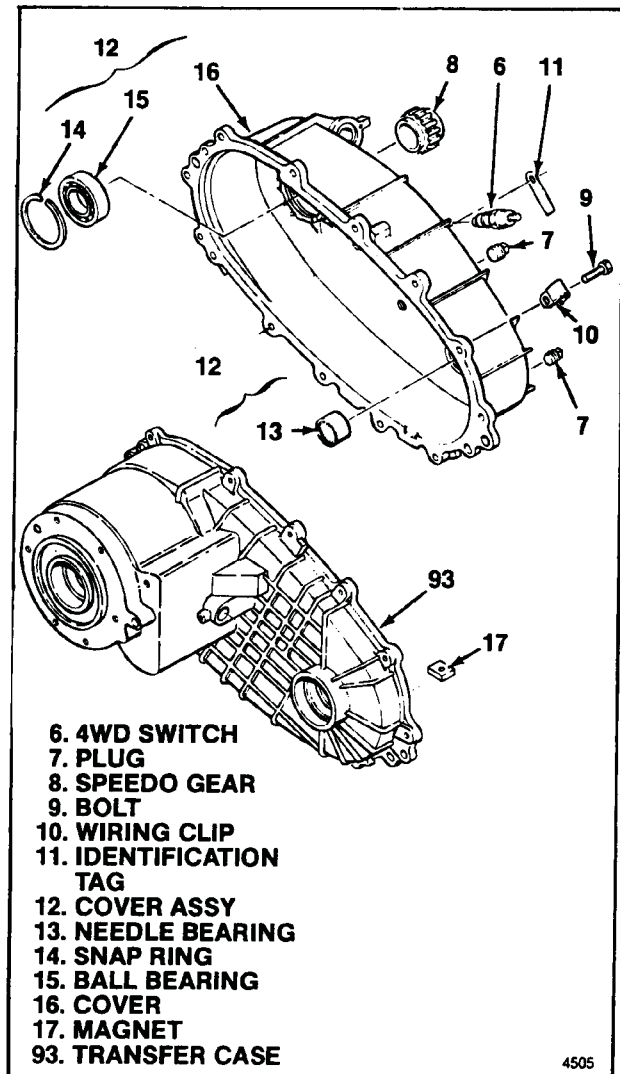

Figure 3-2. Cover Assembly

- g. Remove magnet (17) from slot in case (93).
- h. Scrape and clean sealant from mating faces of (16) and transfer case (93). Use care not to damage metal faces.

3-9. REMOVAL OF LOCKUP SHIFT PARTS. From remaining transfer case assembly (18 through 93), remove the following (see figure 3-2):

- a. Remove shift hub (18) from output shaft (43).
- b. Pry up on spring (21) and remove lower spring retainer (19). Pry down on spring (21) and remove upper spring retainer (19).
- c. Together, slide shift collar (20) and lockup fork (23) from output shaft (43) and lockup rail (54). Remove spring (21) and two fork facings (22) from lockup fork (23).

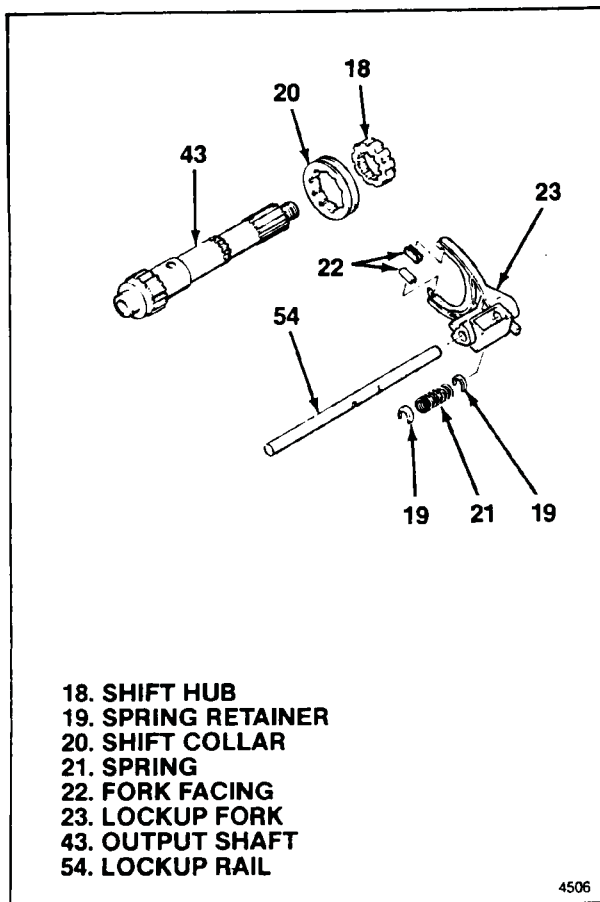

Figure 3-3. Lockup Shift Parts

3-10. REMOVAL OF CHAIN DRIVE. From remaining transfer case assembly (24 through 93), remove the following (see figure 3-4):

- a. Remove snap ring (24) and washer (25) from lower output shaft (84).
- b. Together, slide chain (26), drive sprocket (27) and driven sprocket (28) from upper and lower output shafts (43 and 84). Separate sprockets and chain when out of assembly.
- c. Remove thrust washer (29) from upper output shaft (43).

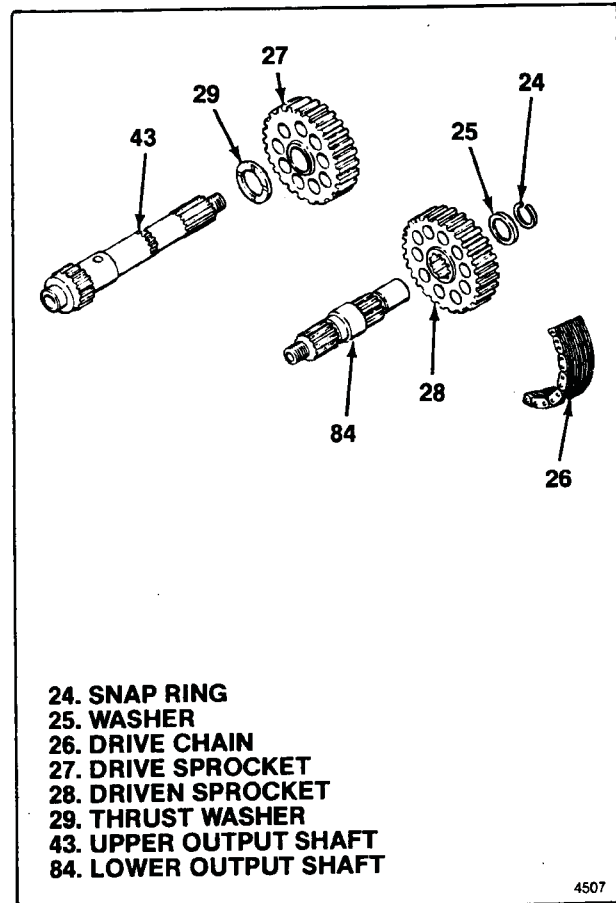
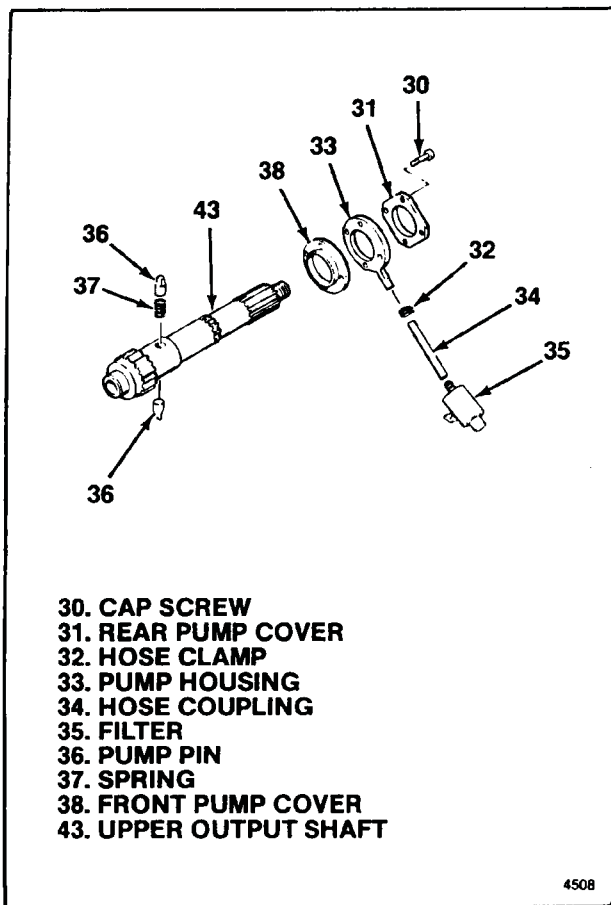

Figure 3-4. Chain Drive

3-11. REMOVAL OF OIL PUMP PARTS. From remaining transfer case assembly (30 through 93) remove the following (see figure 3-5):

- a. Remove four cap screws (30) and slide rear pump cover (31) off upper output shaft (43).
- b. Loosen hose clamp (32) and separate hose coupling (34) from pump housing (33). Slide pump housing off upper output shaft (43).
- c. Remove hose clamp (32), hose coupling (34) and filter (35).
- d. Remove two pump pins (36) and spring (37) from upper output shaft (43).
- e. Slide front pump cover (38) off upper output shaft (43).



- 30. CAP SCREW
- 31. REAR PUMP COVER
- 32. HOSE CLAMP
- 33. PUMP HOUSING
- 34. HOSE COUPLING
- 35. FILTER
- 36. PUMP PIN
- 37. SPRING
- 38. FRONT PUMP COVER
- 43. UPPER OUTPUT SHAFT

4508

Figure 3-5. Pump Parts

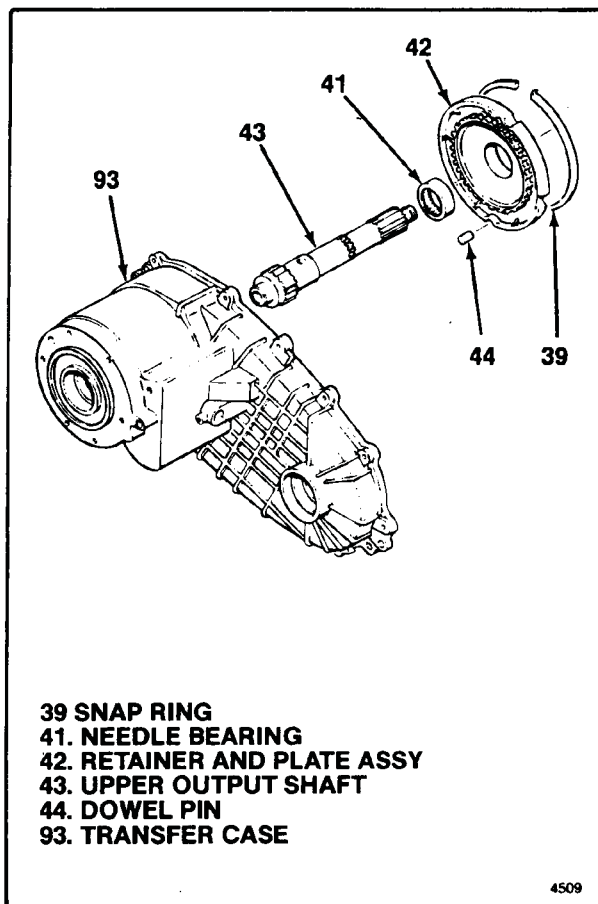

- 39. SNAP RING
- 41. NEEDLE BEARING
- 42. RETAINER AND PLATE ASSY
- 43. UPPER OUTPUT SHAFT
- 44. DOWEL PIN
- 93. TRANSFER CASE

4509

Figure 3-6. Retainer and Upper Output Shaft

3-12. REMOVAL OF RETAINER AND UPPER OUTPUT SHAFT. From remaining transfer case assembly (39 through 93), remove the following (see figure 3-6):

- a. Remove snap ring (39) from groove in transfer case (93) just above retainer and plate assembly (42).
- b. Grasp upper output shaft (43) and pull up while tapping transfer case (93) with plastic mallet to free retainer and plate assembly (42). Separate upper output shaft from retainer and plate assembly.
- c. Pull needle bearing (41) from retainer and plate assembly (42).
- d. Remove two dowel pins (44) used to locate retainer and plate assembly (42) to transfer case (93).

3-13. REMOVAL OF REDUCTION SHIFT, CARRIER AND INPUT SHAFT PARTS. From remaining transfer case assembly (45 through 93), remove the following (see figure 3-7):

- a. Reach into transfer case (93) and remove clip-ring (45) that attaches shift cam (51) to shaft of shift lever assembly (47).
- b. Remove setscrew (46) and shift lever assembly (47). Remove o-ring (48) from shaft of shift lever assembly.

NOTE

When parts are removed as described in following step, thrust washer (74), ball (75) and spring (76) will come free in case. Make sure these parts do not become lost.

c. As an assembly, withdraw reduction shift, carrier and input shaft (49 through 73) from transfer case (93). Separate shift rail and fork group (49 through 59) from carrier and shaft group (60 through 73).

d. Slide shift fork (59) from lockup rail (54) and remove two crescent rings (49), cam roller (50), shift cam (51), cam roller (52) and pin (53).

e. Remove two fork facings (55), retaining clip (56), pin (57) and cam roller (58) from shift reduction fork (59).

f. Separate input shaft assembly (60) from reduction carrier assembly (64). Pull bushing (61) from input shaft (63). Do not remove cup plug (62) unless it is loose or damaged.

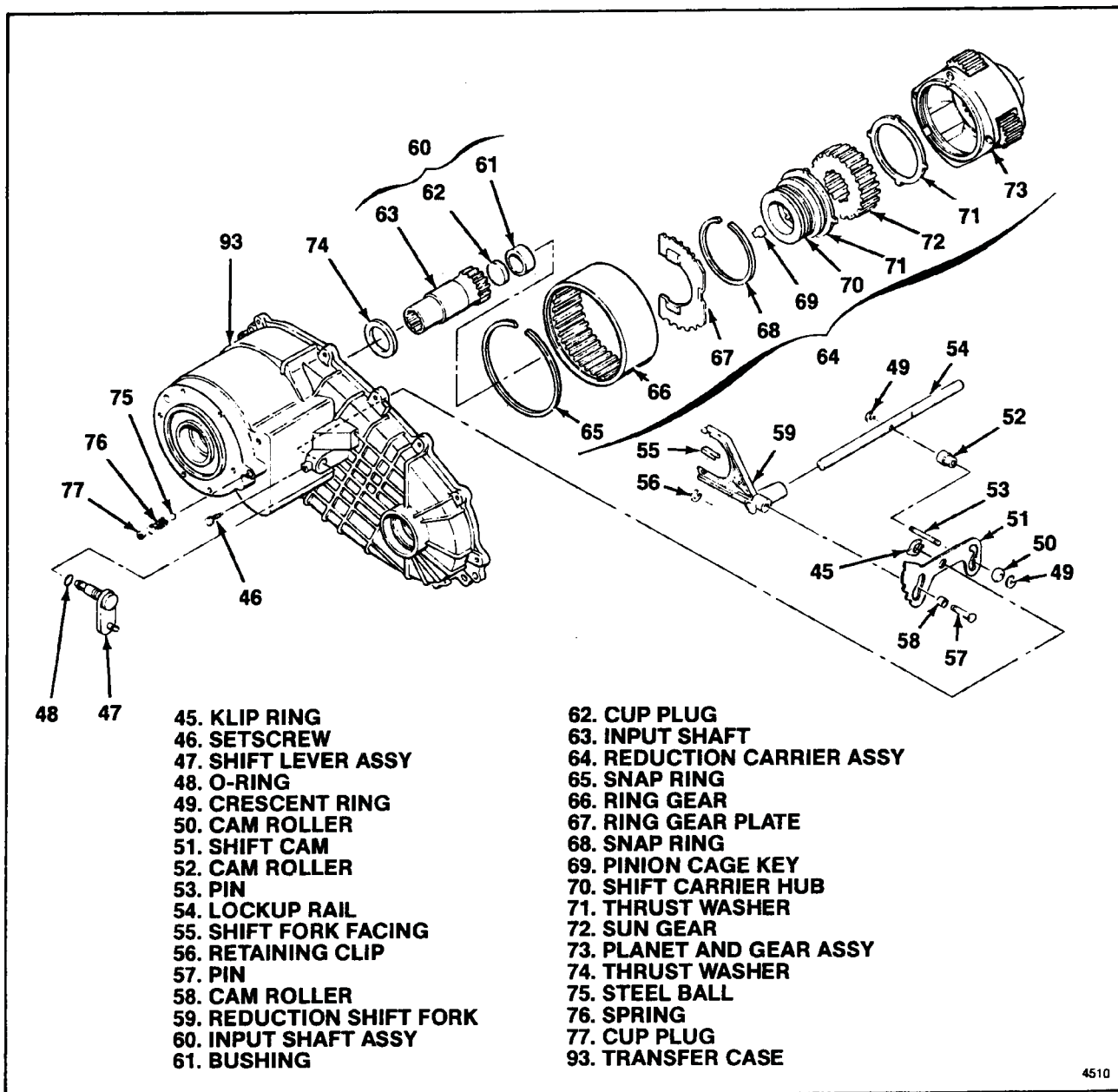

Figure 3-7. Reduction Shift, Carrier and Input Shaft Parts

g. Remove snap ring (65) and ring gear (66) from planet and gear assembly (73).

h. Remove snap ring (68), pinion cage key (69) shift hub (70) and one thrust washer (71). Before removing sun gear (72), mark its outside face so that it can be installed in same position. Then, remove sun gear and remaining thrust washer (71) from planet and gear assembly (73).

i. Remove thrust washer (74), ball (75) and spring (76) from transfer case (93). Using suitable drift, drive cup plug (77) from transfer case (93).

3-14. REMOVAL OF LOWER OUTPUT SHAFT AND YOKE. From remaining transfer case assembly (78 through 93), remove the following (see figure 3-8):

- a. Remove nut (78) and washer (79).

- b. Pull yoke assembly (81) and remove oil seal (80).

- c. Remove lower output shaft (84)

- d. Press dust deflector (82) from yoke (83) only if it is loose or damaged.

3-15. DISASSEMBLY OF TRANSFER CASE ASSEMBLY. Disassemble as follows (see figure 3-9):

- a. Remove breather hose barb (85) from transfer case assembly (86).

- b. Pull oil seal (87).

- c. Remove snap ring (88) and pull ball bearing (89).

- d. Pull oil seal (90).

- e. Pull input shaft bushing (91).

- f. Remove two dowel pins (92) from transfer case (93) only if they are loose or damaged.

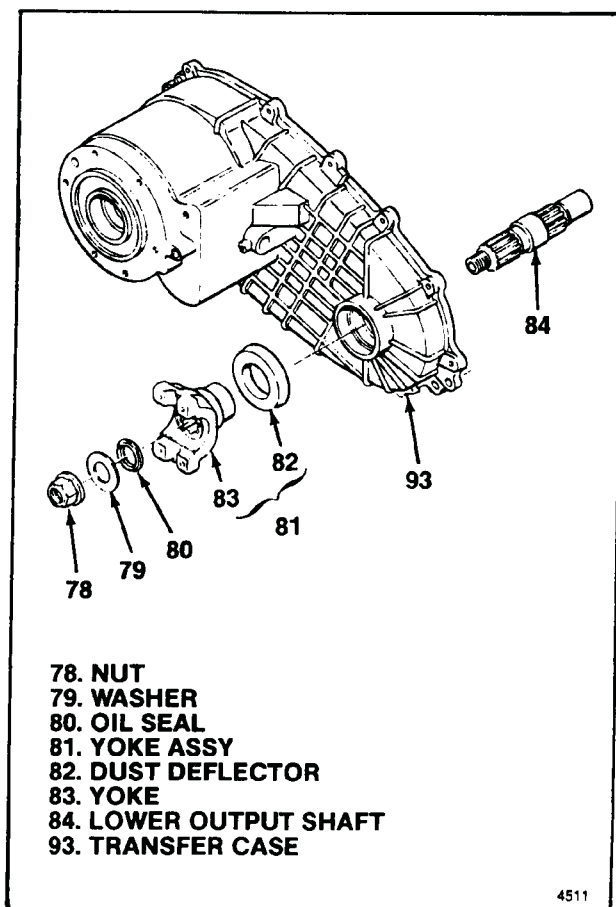

Figure 3-8. Lower Output Shaft and Yoke

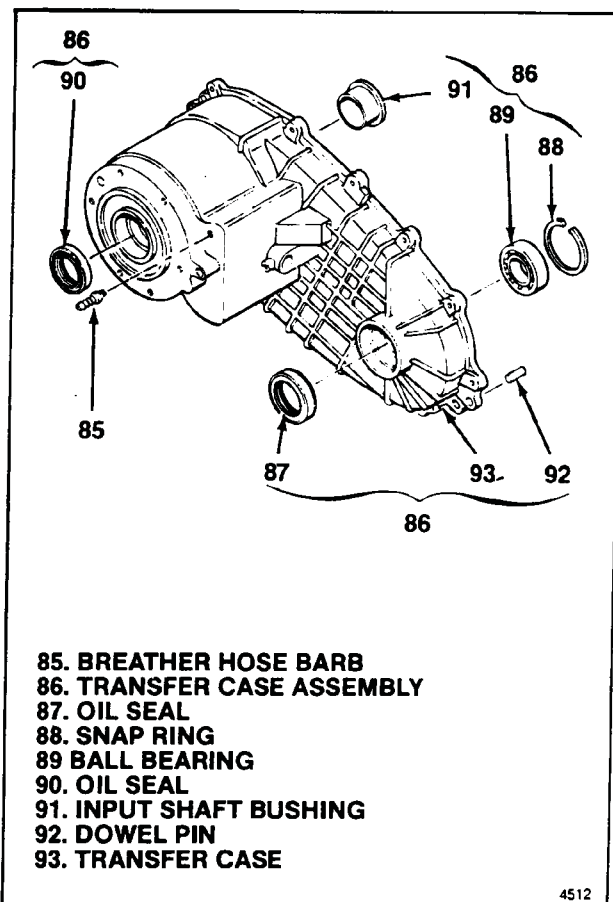

Figure 3-9. Transfer Case Assembly

Cleaning, Inspection, Repair or Replacement

4-1 CLEANING

NOTE: Prior to cleaning, check magnet (17) for presence of metal particles. Larger, granular or irregular shaped particles indicate chipping or similar damage. Smaller, powder-like particles indicate uneven or excessive wear. If metal particles are detected, be on the lookout for damage or wear when inspecting rotating parts and those with which they mate.

4-2. GENERAL CLEANING PROCEDURE.

Wash parts in cleaning solvent to remove old lubricant and dirt deposits. Use a bristle brush to remove caked-on deposits. Parts that cannot be cleaned by brushing may be scraped but use care not to damage metal surfaces.

4-3. DRYING CLEANED PARTS. Dry parts with low pressure (20 psi max) compressed air. Wiping parts dry could leave lint deposits. Hold bearings to prevent them from spinning when drying.

4-4. LUBRICATING BEARINGS. Immediately after cleaning, lubricate ball bearings (15 and 89) and needle bearings (13 and 41) with transfer case lubricant (refer to paragraph 2-4). Rotating or spinning dry, unlubricated bearings could result in damage. Cover lubricated bearings to protect from dust.

4-5. INSPECTION

4-5. GENERAL INSPECTION PROCEDURES.

Visually inspect all parts (except hose coupling, o-ring and oil seals, which should be replaced with new parts) for damage or excessive or uneven wear. Reject parts with damage or wear that would affect serviceability of the part. Inspection terms used in this section are as follows:

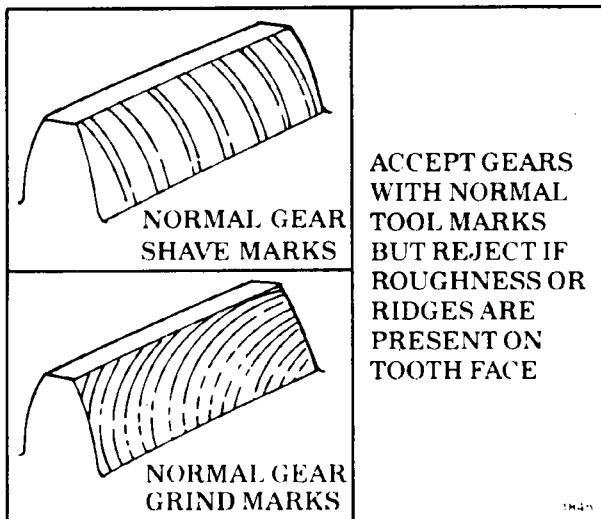

Figure 4-1. Normal Gear Tooth Tool Marks

Burr: Local rise of material forming protruding sharp edge.

Chip: An area from which a small fragment has been broken off or cut.

Crack: Surface break of line nature indicating partial or complete separation of material.

Excessive wear: Heavy or obvious wear beyond expectations considering conditions of operation.

Indentation: Displacement of material caused by localized heavy contact.

Galling: Breakdown (or build-up) of metal surface due to excessive friction between parts. Particles of the softer material are torn loose and welded to the harder material.

Nick: Local break or notch. Usually displacement of material rather than loss.

Scoring: Tear or break in metal surface from contact under pressure. May show discoloration from heat produced by friction.

Step wear: Heavy wear that produces a step that can be seen or felt between adjacent contact and non-contact surfaces

Uneven wear: Condition of localized, unevenly distributed wear. Includes hollows, shiny spots, uneven polish and other visual indications.

4-7. SPECIFIC INSPECTION PROCEDURES

Inspect parts in accordance with Table 4-1 and as specified in the following paragraphs. Index numbers used in Table 4-1 are those assigned to the exploded view in Section P, Parts.

4-8. GEAR OR SPROCKET TEETH INSPECTION. When specified in Table 4-1, inspect gear or sprocket teeth as follows:

NOTE: Do not confuse contact patterns with normal tool marks that are a result of manufacture. Typical tool marks are shown in figure 4-1.

a. Check gear or sprocket tooth contact patterns. Contact patterns likely to be encountered are shown in figure 4-2. Parts with contact patterns shown in the ACCEPT column are OK for further service provided they meet all other inspection requirements. Parts with contact patterns shown in REJECT column are unacceptable and must be rejected—no repairs are authorized.

b. Check gear or sprocket teeth for chips. Compare tooth chips or nicks with those shown in figure 4-3. Parts with small chips as shown in REPAIR column may be blend-repaired (refer to paragraph 4-12) and reused. Chips or broken teeth as shown in REJECT column are not repairable and the part must be rejected.





DESCRIPTION	ACCEPT	REJECT
DESIRED CONTACT PATTERN		
END CONTACT PATTERN		
TRAVELING CONTACT PATTERN (MOVES FROM SIDE TO SIDE)		
HIGH CONTACT PATTERN		
LOW CONTACT PATTERN		

Figure 4-2. Gear Tooth Contact Patterns

1846

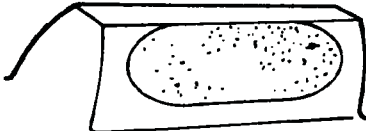
REPAIR		REJECT	
CORNER CHIP AT DRIVE FACE		CHIP WITHIN CONTACT PATTERN	
O.D. EDGE CHIP AT DRIVE FACE. MAY EXTEND SLIGHTLY INTO CONTACT PATTERN		CHIP COMPLETELY THROUGH TOOTH (CONSIDERED TO BE BROKEN)	
CORNER CHIP AT COAST FACE		<p>4-9. SPLINE TEETH INSPECTION. Check for broken or chipped spline teeth. Small chips may be blend-repaired in same manner as gear teeth (see figure 4-2 and refer to paragraph 4-12). If any spline tooth is broken, the part must be rejected. Spline teeth will not show contact patterns as gear teeth do. However, they may show evidence of step wear which is cause for rejection.</p>	
SIDE EDGE CHIP AT DRIVE FACE			

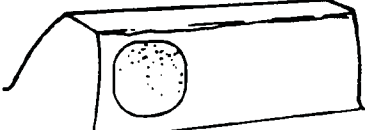
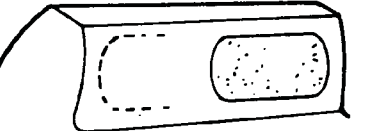
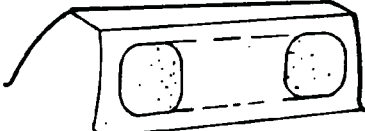
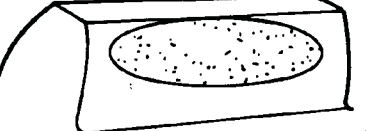
1847

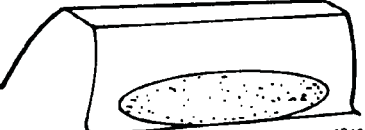
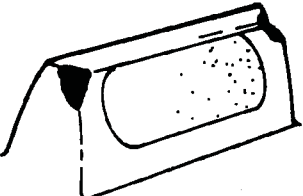
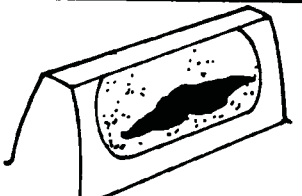
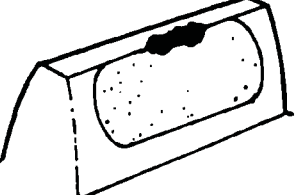
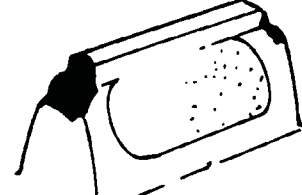
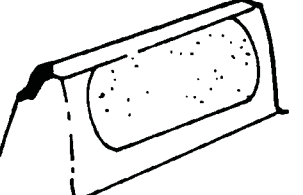
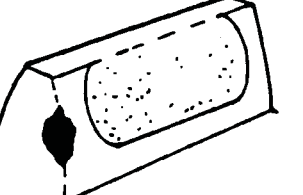
Figure 4-3. Gear Tooth Chips

Assembly

5-1. GENERAL INFORMATION

5-2. During assembly, refer to the illustrations specified in the text. In addition, an exploded view of the complete assembly can be viewed on the illustration in Section P, Parts. Note the following during assembly:

a. When a torque value is specified, use a torque wrench to tighten the threaded part. Torque values are specified in the text and also in Table 5-1 at the end of this section.

b. Liberally coat small parts with petrolatum to help hold them in place during assembly.

c. Press in oil seals and bearings using a suitable drift. Do not use a hammer to drive in oil seals and bearings.

5-3. LUBRICATION DURING ASSEMBLY.

Lubricate all internal parts, not coated with petrolatum, with approved transfer case lubricant (refer to paragraph 2-4) just prior to assembly. This will ease assembly and provide initial lubrication.

a. O-rings or shaft seals may be damaged if not lubricated prior to assembly.

b. Make sure bearings and bushings are thoroughly lubricated before assembly. Running bearings or bushings dry, even for a brief period, will cause damage.

c. Lubricate sealing lips of oil seals and mating metal parts prior to assembly together.

5-4. ASSEMBLY OF TRANSFER CASE

5-5. ASSEMBLY OF CASE ASSEMBLY. Assemble parts which were removed from transfer case as follows (see figure 5-1):

a. If removed, press two new dowel pins (92) into case so that they project 0.365-0.395 in. (9.27-10.03 mm) above face of case.

b. Note that bushing (91) has a key on its OD in line with flat on the bushing flange. Note also that bushing bore in transfer case (93) has a groove. Align bushing key with bore groove. Using suitable drift, press in bushing until its flange seats against inside face of case.

c. Make sure bore in transfer case (93) for oil seal (90) is free from oil or grease. Apply a thin film of Loctite 609 to case bore. Position new oil seal (90) as shown in figure 5-2 and press into dimension shown using suitable drift.

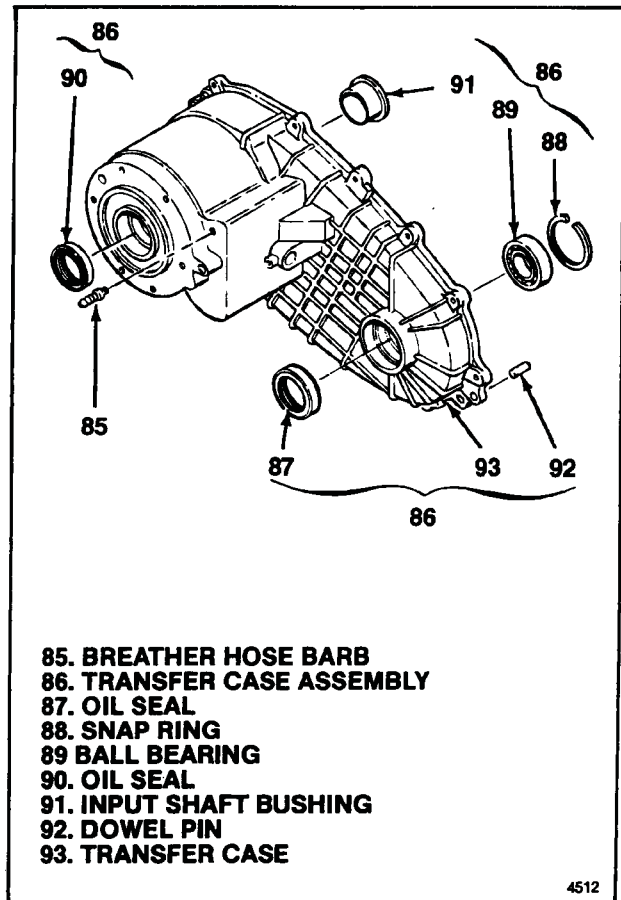

Figure 5-1. Transfer Case Assembly

d. Using suitable drift, press in ball bearing (89) to bottom in transfer case (93) and install snap ring (88).

e. Position new oil seal (87) as shown in figure 5-3 and press in transfer case (93) to dimension shown using suitable drift.

f. Install breather hose barb (85) in transfer case (93) and torque to 6-14 lb-ft (8-19 Nm).

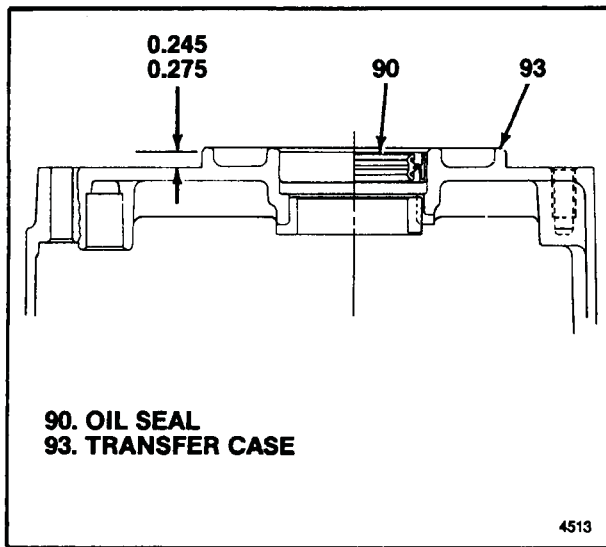
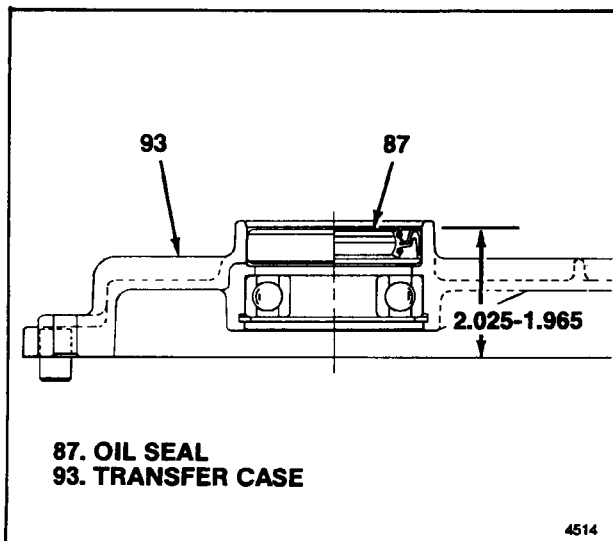

Figure 5-2. Installing Input Shaft Oil Seal Figure



5-3. Installing Output Shaft Oil Seal

5-6. INSTALLING LOWER OUTPUT SHAFT AND YOKE. To assembly as completed thus far (85 through 93), install parts as follows (see figure 5-4):

- If removed, press dust deflector (82) onto yoke (83) to seat against yoke shoulder.
- Lubricate oil seal (80) and install over threads of lower output shaft (84) with sealing bead on oil seal facing out. Seat oil seal on shaft shoulder.
- Insert lower output shaft (84) through ball bearing in transfer case (93), hold in position and install yoke assembly (81). Attach with washer (79) and nut (78). Tighten nut just enough to hold shaft securely but do not torque at this time.

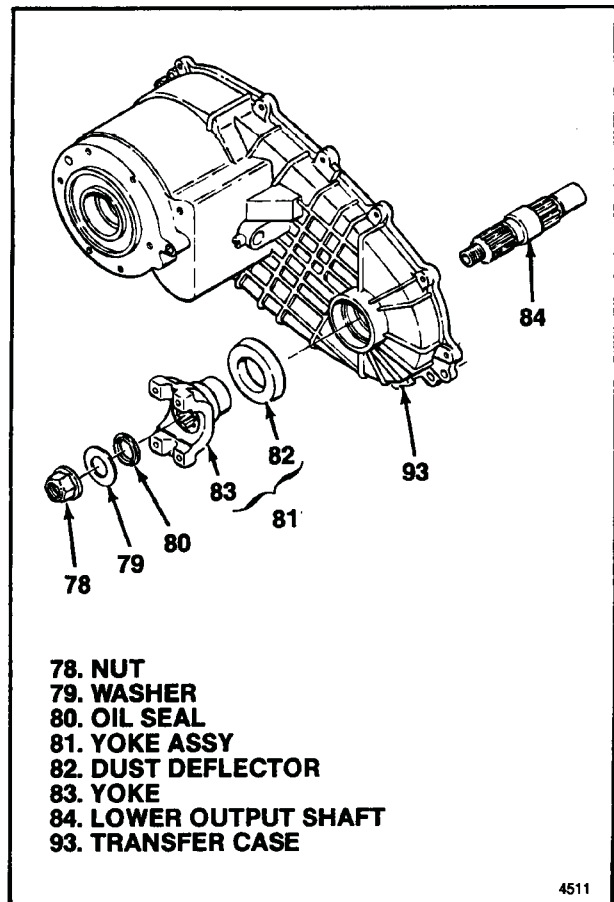

Figure 5-4. Lower Output Shaft and Yoke

5-7. ASSEMBLY OF CARRIER AND INPUT SHAFT GROUP. On work bench, assemble parts as follows (see figure 5-5):

- Lay planet and gear assembly (73) on work bench with open side up, splined end down.
- Insert one thrust washer (71) into planet and gear assembly (73) with washer tabs between gears. Then, rotate thrust washer until its tabs line up with notches in planet and gear assembly and drop into place.
- Install sun gear (72) with side marked at disassembly up. Rotate gears of planet and gear assembly (73) as required until sun gear is fully meshed and resting against thrust washer (71) previously installed.
- Apply petrolatum to face of remaining thrust washer (71) to hold it in place and install in shift hub (70) with washer tabs in hub notches. Install shift hub in planet and gear assembly so that notch on hub flange aligns with that in planet and gear assembly. The two notches will form a T shaped recess. Install pinion cage key (69) in this recess.
- Retain shift hub (70) in planet and gear assembly (73) with snap ring (68).

f. Slide ring gear plate (67) into groove in OD of shift hub (70). Make sure plate goes into narrow groove, not the wider groove for shift fork.

g. Place ring gear (66) on two 3/8 in. (9.5 mm) spacers on work bench with snap ring groove up. Lower planet and gear assembly and assembled parts (67 through 73) into ring gear. Rotate planet and gear assembly (67) to align gear teeth and ring gear plate (67) to align its teeth with 10 of those in ring gear.

h. If removed, press in cup plug (62) to bottom in input shaft (63). Press in new bushing (61) until its outside end is flush with bottom of chamfer in input shaft (63).

i. Install input shaft assembly (60) into reduction carrier assembly (64). Install assembly tool T-13-45-001 as shown in figure 5-6 and tighten hand knobs securely to hold assembly in neutral and together for installation later.

5-8. ASSEMBLY OF REDUCTION SHIFT FORK, RAIL AND CAM. On work bench, assemble parts as follows (see figure 5-7):

a. Insert pin (57) through cam roller (58) and into reduction shift fork (59). Attach with retaining clip (56). Make sure that cam roller turns freely.

b. Install two fork facings (55) on reduction shift fork (59).

c. Install one crescent ring (49) in groove at one end of pin (53). Insert pin through hole in lockup rail (54). Install stepped cam roller (52) over free end of pin (53) and position assembly on work bench with roller pointing up.

d. Hold shift cam (51) over the roller-pin-rail assembly (52 through 54) in the position shown in figure 5-7. Make sure that the side of the cam with the raised hub reinforcement is up. Lower cam into position with the longer cam track going over roller (52). Install roller (50) and remaining crescent ring (49).

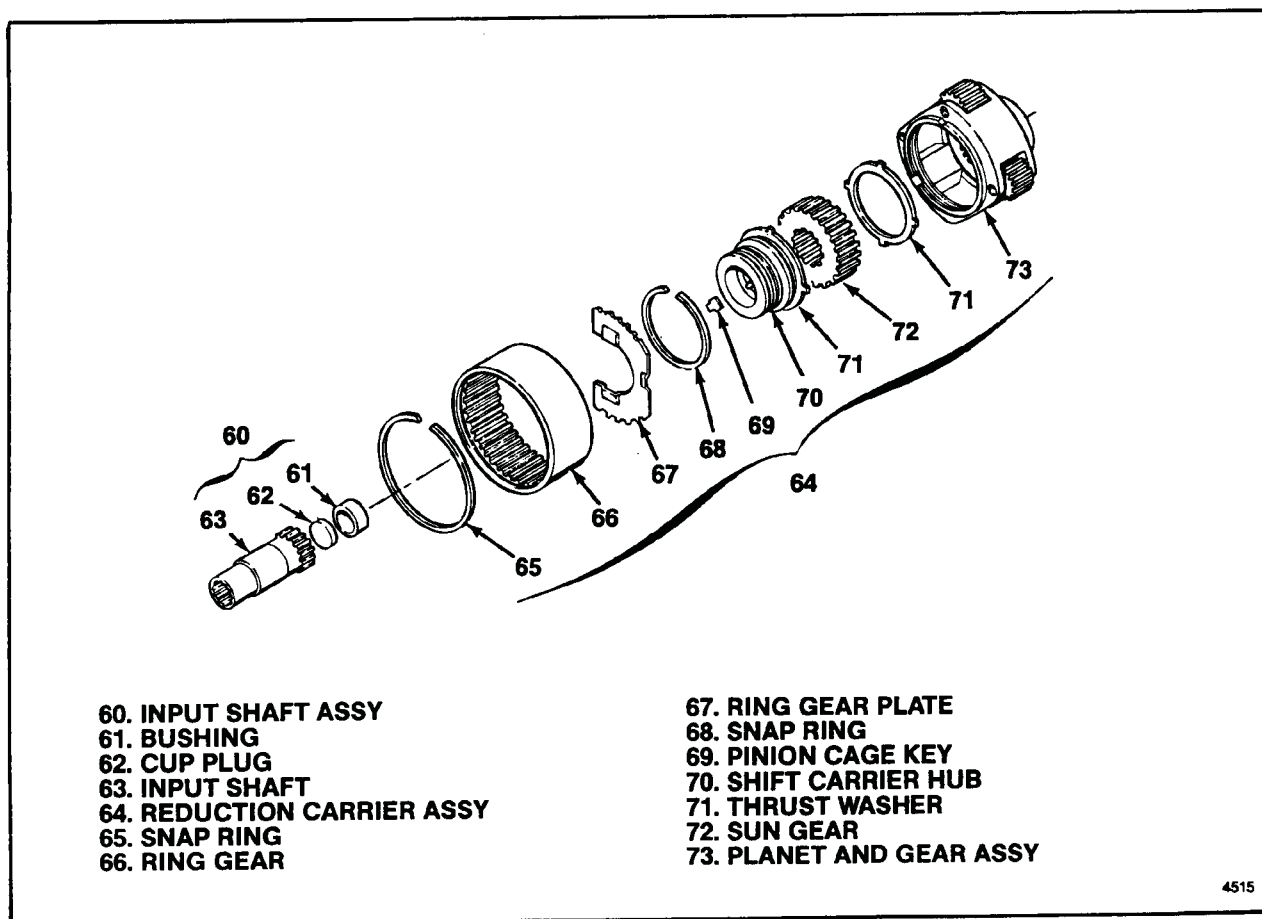

4515

Figure 5-5. Carrier and Input Shaft Group

e. Slide reduction shift fork (59) onto lockup rail (54), long hub end first. Engage cam roller (58) in open track in cam (51).

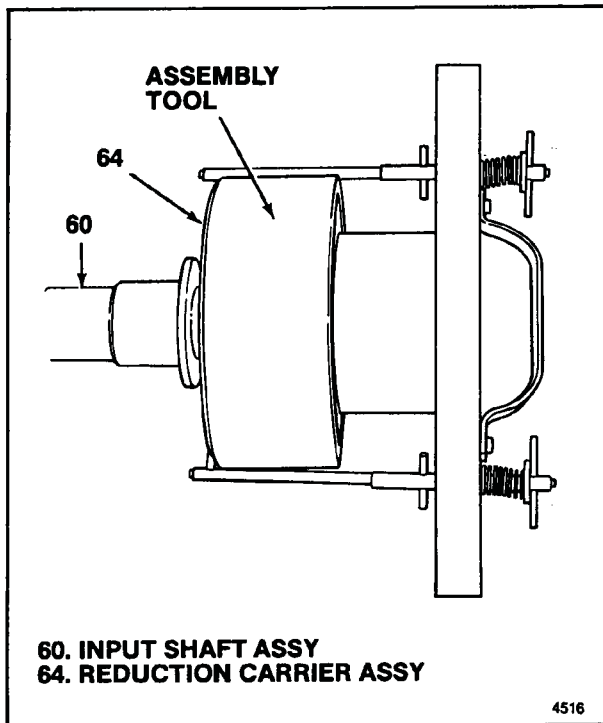

Figure 5-6. Holding Parts Together With Assembly Tool

5-9. INSTALLATION OF REDUCTION SHIFT, CARRIER AND INPUT SHAFT GROUP IN TRANSFER CASE. Position transfer case and lower output shaft assembly (78 through 93) on workbench, open face of case up. Use wooden blocks under lower output yoke to keep face of case level. Proceed as follows (see figure 5-8):

a. Apply petrolatum to thrust washer (74) to help hold in place and center on bushing in transfer case assembly (86).

b. Bring the previously assembled (paragraphs 5-7 and 5-8) carrier and input shaft group (retained with assembly tool T-13-45-001) and reduction shift fork, rail and cam group together by engaging reduction shift fork (59) with groove in shift hub (70). Holding these two groups together, lower into transfer case assembly (86) (see figure 5-9), meeting following conditions:

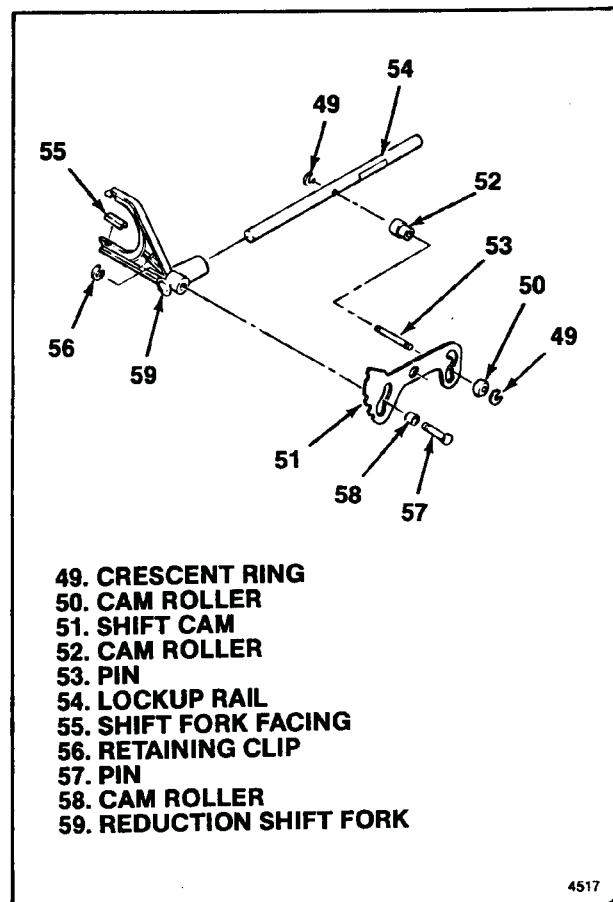

Figure 5-7. Reduction Shift Fork, Rail and Cam Parts

1. Input shaft (63) must go through thrust washer (74) and bushing in transfer case assembly (86).

2. End of lockup rail (54) must enter hole in transfer case assembly (86).

3. Cam roller (50) must rest in cradle provided in transfer case assembly (86).

c. Install o-ring (48) in groove in shaft of shift lever assembly (47).

d. Holding shift lever assembly (47) in neutral position (see figure 5-10) insert through transfer case assembly (86) and splines of shift cam (51). Install klip ring (45) in groove in shift lever assembly to retain it in shift cam.

e. Apply Loctite 242 to threads of setscrew (46) and install in transfer case assembly (86). Torque setscrew to 5.0- 7.0 lb-ft (6.8-9.5 Nm)

f. Remove assembly tool T-13-45-001.

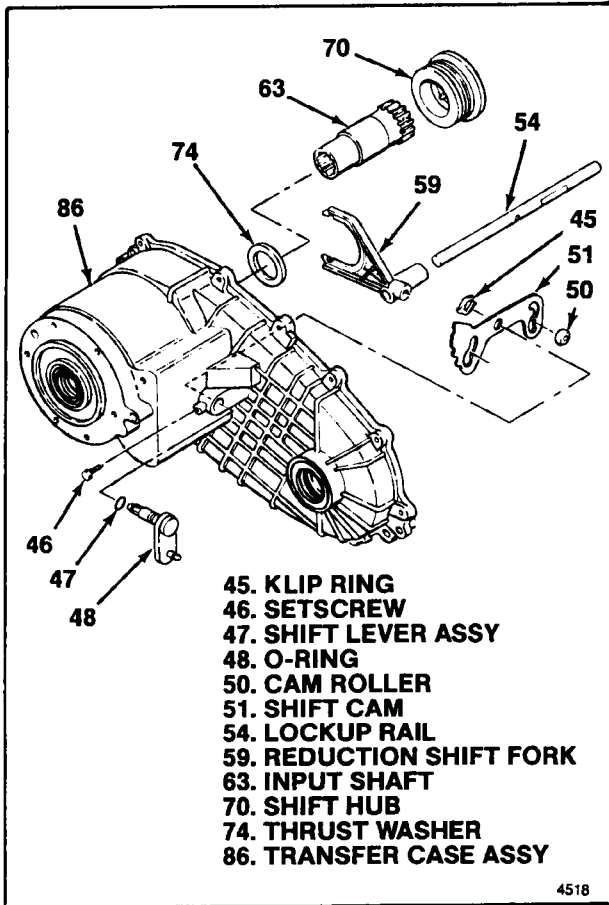

Figure 5-8. Installation of Reduction Shift, Carrier and Input Shaft Group

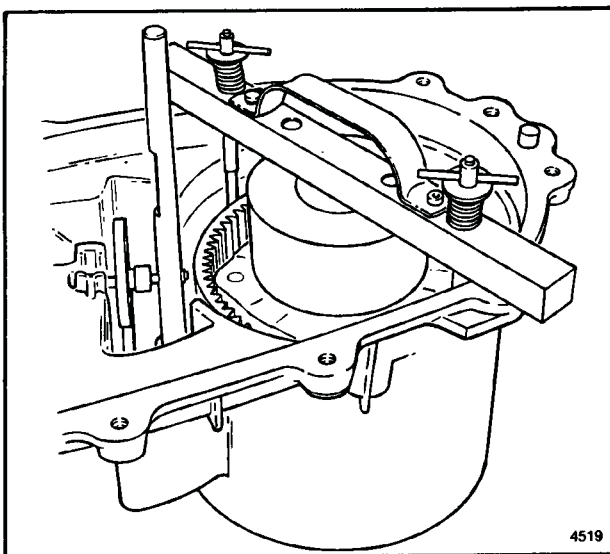

Figure 5-9. Reduction Shift, Carrier and Input Shaft Group in Transfer Case

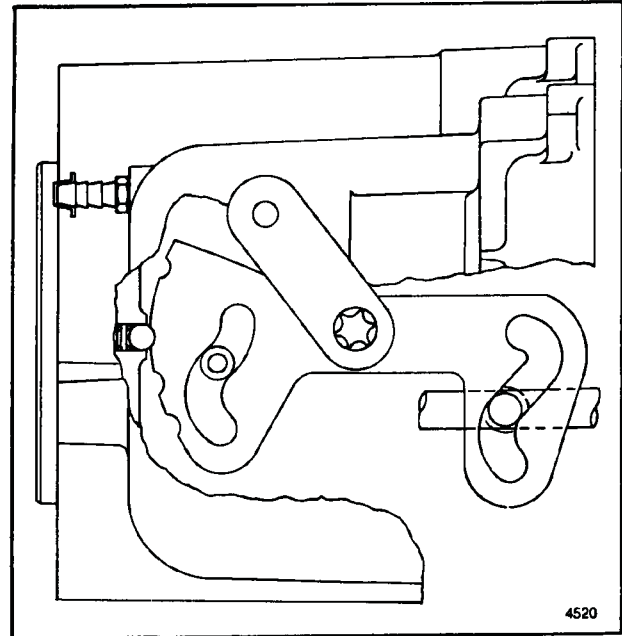

Figure 5-10. Shift Lever Assembly in Neutral Position

NOTE

Installation of retainer and upper output shaft (paragraph 5-10) may be deferred and oil pump assembled to upper output shaft and retainer (paragraph 5-11) on work bench. Bench assembled, pump can be tested by immersing filter in transmission oil (Table 2-2) and rotating shaft in counterclockwise direction when viewed from output end. Assembled parts then can be installed in transfer case as a unit.

5-10. INSTALLATION OF RETAINER AND UPPER OUTPUT SHAFT. To assembly as completed thus far (45 through 93), install parts as follows (see figure 5-11).

a. Install spline of upper output shaft (43) in mating spline of planet and gear assembly in transfer case assembly (86).

b. Position retainer and plate assembly (42) on bed of suitable press with open face down. Position needle bearing (41) over retainer and plate assembly with end of bearing having identification markings up. Using suitable drift, press bearing into retainer and plate assembly until end of bearing with identification markings is 1.405-1.375 in. (35.69-34.93 mm) above surface of press bed.

c. Install retainer plate and bearing assembly (40) over upper output shaft (43) in transfer case assembly (86). Align semi-circular notches in plate OD with those in case ID before seating retainer plate. Install two dowel pins (44) in aligned notches.

d. Install snap ring (39) in groove in transfer case assembly (86) to retain retainer plate and bearing assembly.

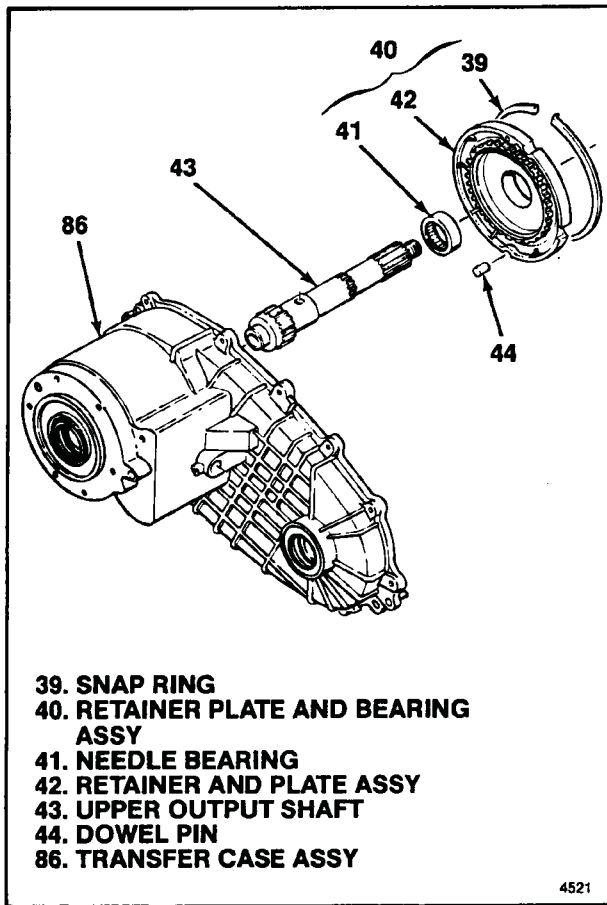

Figure 5-11. Retainer and Upper Output Shaft

5-11. INSTALLING OIL PUMP. Be sure to thoroughly lubricate pump parts as they are assembled but keep oil out of tapped holes in pump front cover. To assembly as completed thus far (39 through 93) assemble parts as follows (see figure 5-12):

a. Locate pump front cover (38). Front pump cover has tapped holes. Position front cover so that word TOP faces down and turned so that it will be at top of transfer case when installed in vehicle. Install front pump cover (38) over upper output shaft (43) in this position.

b. Install two pump pins (36) with spring (37) between them in upper output shaft (43). Flat surface on both pins must point out and face up. Center pins and spring in output shaft.

c. Push hose coupling (34) onto barb on filter (35) and install L shaped foot on filter in slot in transfer case assembly (86). Hose coupling must point in direction of pump assembly.

d. Install pump housing (33) so that word REAR marked on it is up and hose barb points toward hose coupling (34) and filter (35). Lower pump housing over upper output shaft, moving pump pins (36) inward and compressing spring (37) so that both pins are contained inside pump housing.

e. Slip hose clamp (32) over free end of hose coupling (34) and push onto hose barb on pump housing (33). Secure hose clamp over hose coupling on hose barb.

e. Position pump rear cover (31) over assembly with words TOP REAR facing up and located to be at top of transfer case when installed. Clean threads on four cap screws (30) and apply Loctite 222. Align pump holes and install cap screws. Torque cap screws to 36-49 lb-in. (4.1-5.5 Nm) while turning upper output shaft (43) by hand to insure that pump pins (36) move freely.

f. Make sure that upper output shaft (43) turns freely in oil pump assembly. If not, disassemble, check and remedy cause.

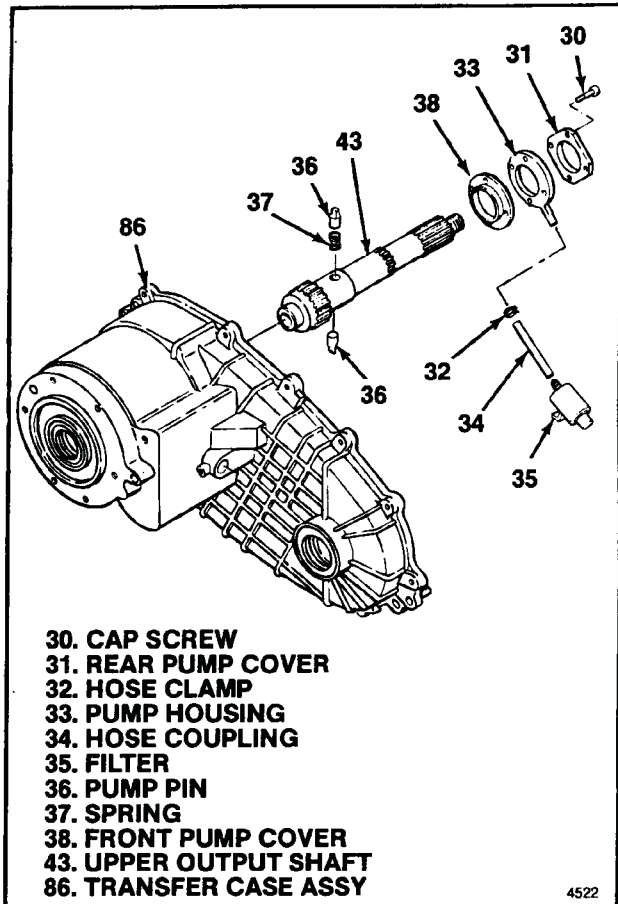

Figure 5-12. Pump Parts

5-12. INSTALLATION OF CHAIN DRIVE. To assembly as completed thus far (30 through 93) assemble parts as follows (see figure 5-13):

a. Install thrust washer (29) so that it seats on shoulder of upper output shaft (43).

b. On work bench, next to transfer case assembly, position driven sprocket (28) (with internal spline) at lower output shaft (84) end of case and drive sprocket (27) (with smooth bore) at upper output shaft (43) end.

c. Assemble drive chain (26) around sprockets (27 and 28).

d. Grasp each sprocket (27 and 28), hold drive chain (26) tight and parallel with transfer case, and install chain drive assembly (26 through 28) over output shafts (84 and 43). It may be necessary to rotate driven sprocket (27) slightly to engage splines on lower output shaft (84).

e. Install washer (25) on lower output shaft (84). Install snap ring (24) in shaft groove over washer.

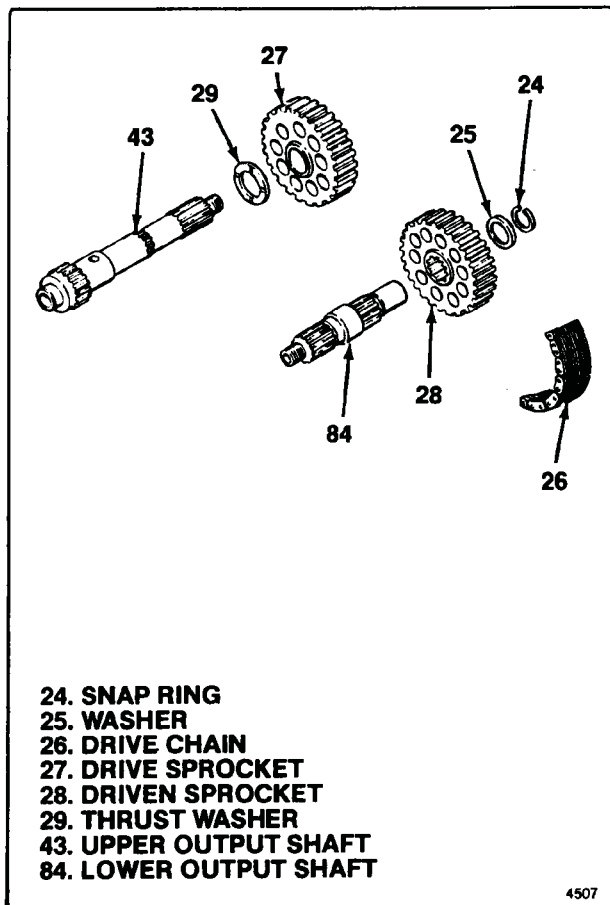

Figure 5-13. Chain Drive

d. Pry down on spring (21) and install upper spring retainer (19) on lockup rail (54). Flat on spring retainer must be aligned with flat on lockup rail. Pry up on spring and install lower spring retainer in same manner.

e. Install shift hub (18) over spline on upper output shaft (43).

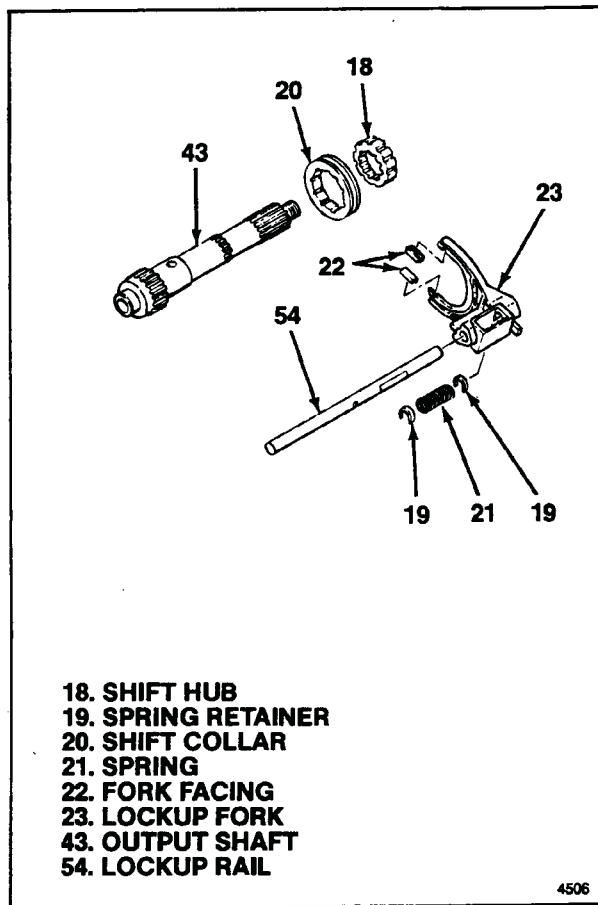

Figure 5-14. Lockup Shift Parts

5-13. INSTALLING LOCKUP SHIFT PARTS. To assembly as completed thus far (24 through 93) install parts as follows (see figure 5-14):

- Install two fork facings (22) on lockup fork (23).
- Position spring (21) in lockup fork (23).
- In one hand, hold lockup fork (23) with hub extension (containing spring) down. In other hand, hold shift collar (20) with hub extension up. Bring parts together engaging lockup fork in hub extension groove. Install assembled parts with shift collar onto upper output shaft (43) and lockup fork and spring (21) onto lockup rail (54).

5-14. COVER ASSEMBLY. Assemble parts into cover as follows (see figure 5-15):

- Position cover (16) on bed of suitable press so that open face of cover is up and parallel with press bed.
- Using suitable drift, press in ball bearing (15) to bottom in cover (16) and install snap ring (14).
- Position end of needle bearing (13) with identification marking up. Using suitable drift, press bearing into cover (16) until upper end of bearing is 2.785-2.815 in. (70.7-71.5 mm) below face of cover that mates with transfer case.

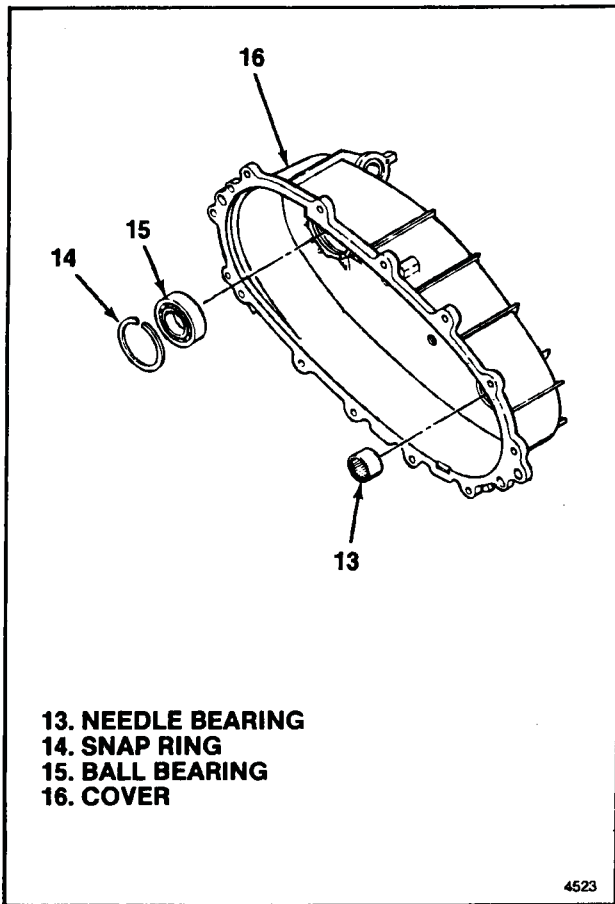

Figure 5-15. Cover Assembly

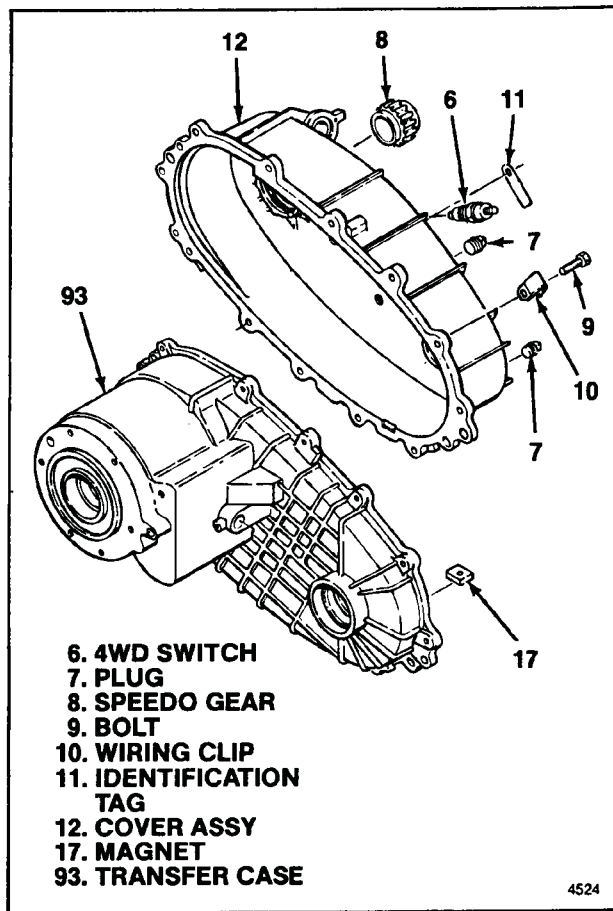

Figure 5-16. Cover Installation

5-15. INSTALLING COVER ASSEMBLY. To assembly as completed thus far (18 through 93) install parts as follows (see figure 5-16):

- a. Install magnet (17) in slot in transfer case (93).
- b. Apply continuous 1/16 in. (1.6 mm) bead of sealant (Silastic RTV No. 732 or General Electric Silmate RTV No. 1473) all around transfer case (93) mounting face for cover assembly (12). Center sealant bead between edges of face. Circle or lay double thickness sealant bead through bolt holes.
- c. Install cover assembly (12) on transfer case (93), aligning dowel pins (92) and guiding output shaft (43, figure 5-14) through cover. It may be necessary to use screwdriver to position lockup rail (54, figure 5-14) to enter hole in cover.
- d. Install twelve bolts (9) positioning identification tag (11) and wiring clip (10) under bolt heads at locations shown in figure 5-17. Torque bolts to 40-45 lb-ft (54.2-61.0 Nm).
- e. Install speedo gear (8) over spline of output shaft (43, figure 5-14), into cover assembly (20).
- f. Install two plugs (7) and torque to 10-20 lb-ft (13.6-27.1 Nm).
- g. Install 4WD switch (6) and torque to 8.0-12.0 lb-ft (10.9-11.3 Nm).

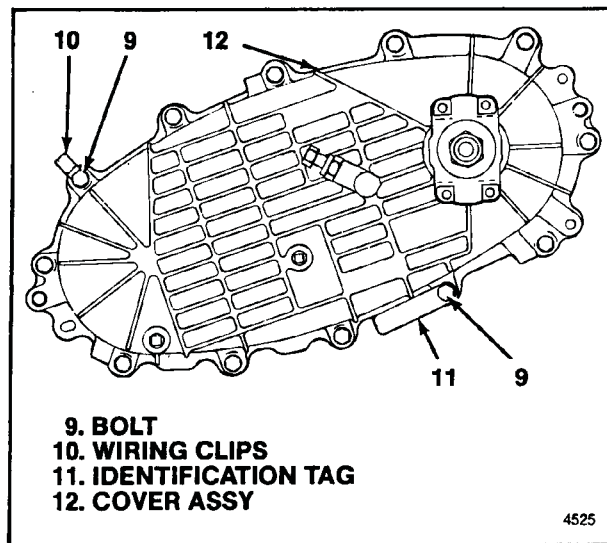

Figure 5-17. Wiring Clip and Identification Tag Locations

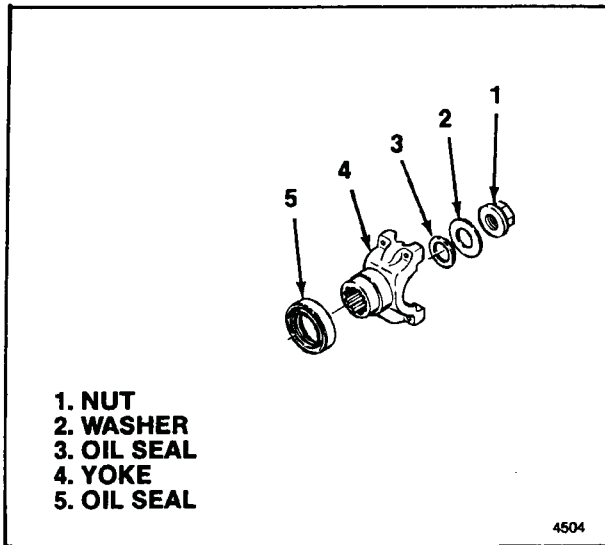

Figure 5-18. Rear Yoke Group

5-16. INSTALLING REAR YOKE GROUP. To assembly as completed thus far (6 through 93) install parts as follows (see figure 5-18):

a. Position oil seal (5) over cover with side marked **OUTSIDE** up. Using suitable drift, press in oil seal until outside end is flush with bottom of chamfer in cover.

b. Fit oil seal (3) on output shaft with sealing bead facing out. Install yoke (4), washer (2) and nut (1). Torque nut (1) and nut (78, figure 5-4) on lower output shaft to 150-180 lb-ft (203-244 Nm).

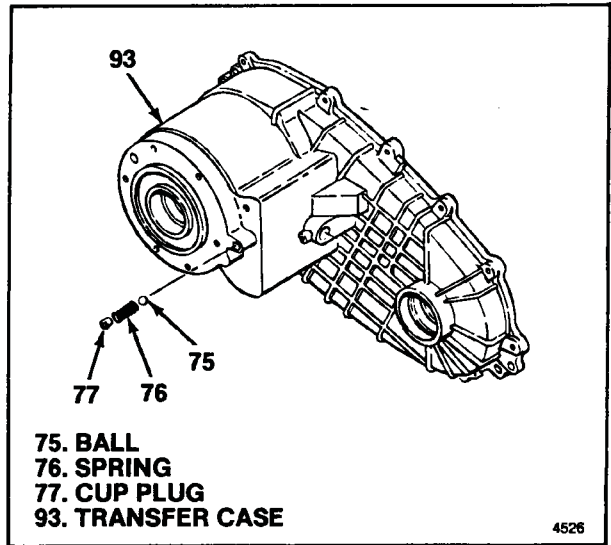

Figure 5-19. Installing Cam Ball and Spring

5-17. INSTALLING CAM BALL AND SPRING. See figure 5-19 and proceed as follows:

a. Insert ball (75) and spring (76) into transfer case (93).

b. Apply Loctite 222 to OD of cup plug (77). Drive in cup plug, closed end first, until open end of cup plug is 1/16 in. (1.6 mm) below face of transfer case (93).

**Table 5-1. Torque Values
TORQUES FOR SPECIFIC PARTS**

PART (INDEX NO.)	TORQUE IN LB-FT	TORQUE IN Nm
Nut (1 and 78)	150-180	203-244
4WD Switch (6)	8.0-12.0	10.9-11.3
Plug (7)	10-20	13.6-27.1
Bolt (9)	40-45	54.2-61.0
Cap Screw (30)	3.0-4.1	4.1-5.5
Setscrew (46)	5.0-7.0	6.8-9.5
Breather Barb (85)	6-14	8-19

Table 5-1. Torque Values (cont.)

GENERAL TORQUES

THREAD SIZE	TORQUE IN LB-FT	TORQUE IN Nm
5/16-18 UNC	15.0-25.0	20.3-33.9
3/8-16 UNC	25.0-40.0	33.9-54.5
3/8-24 UNF	25.0-40.0	33.9-54.5
7/16-14 UNC	35.0-55.0	47.5-74.6
1/2-13 UNC	45.0-70.0	61.0-94.9
1/2-30 UNF	45.0-70.0	61.0-94.9
9/16-12 UNC	60.0-90.0	81.3-122.0
1/8-27 NPTF	7.0-15.0	9.5-20.3
1/4-18 NPTF	10.0-20.0	13.6-27.1
3/8-18 NPTF	15.0-25.0	20.3-33.9
1/2-14 NPTF	20.0-30.0	27.1-40.7
3/4-14 NPTF	25.0-40.0	33.9-54.5

Parts Contents

FIGURE NO.	DESCRIPTION	APPLICATION
P-1	Transfer Case Assembly	13-45

P-1. INTRODUCTION.

P-2. This section lists, describes and illustrates replacement parts for the Borg-Warner Automotive 13-45 Transfer Case. The exploded view illustration, listed in the Contents, has a corresponding parts list. Index numbers are used to key each part in the exploded views to the parts list and service instructions in preceding sections of this manual.

P-3. The PART NUMBER column in the parts list gives the part number which can be used to order replacement parts. Complete information on the identification tag (11, figure P-1) should be included with all parts orders (see figure 1-1).

P-4. The DESCRIPTION column gives the part nomenclature used, not only in the list but also in the service instructions.

P-5. The QTY column designates the number of parts used at the location defined by the index number. Letter symbols may be used in this column to designate specific information. The symbols are as follows:

a. **AR**—As Required. This is used for selective fit parts, determined as necessary at assembly.

b. **NP**—Not Procurable. Detail parts so designated are not procurable separately. When replacement is required, order the next higher assembly.

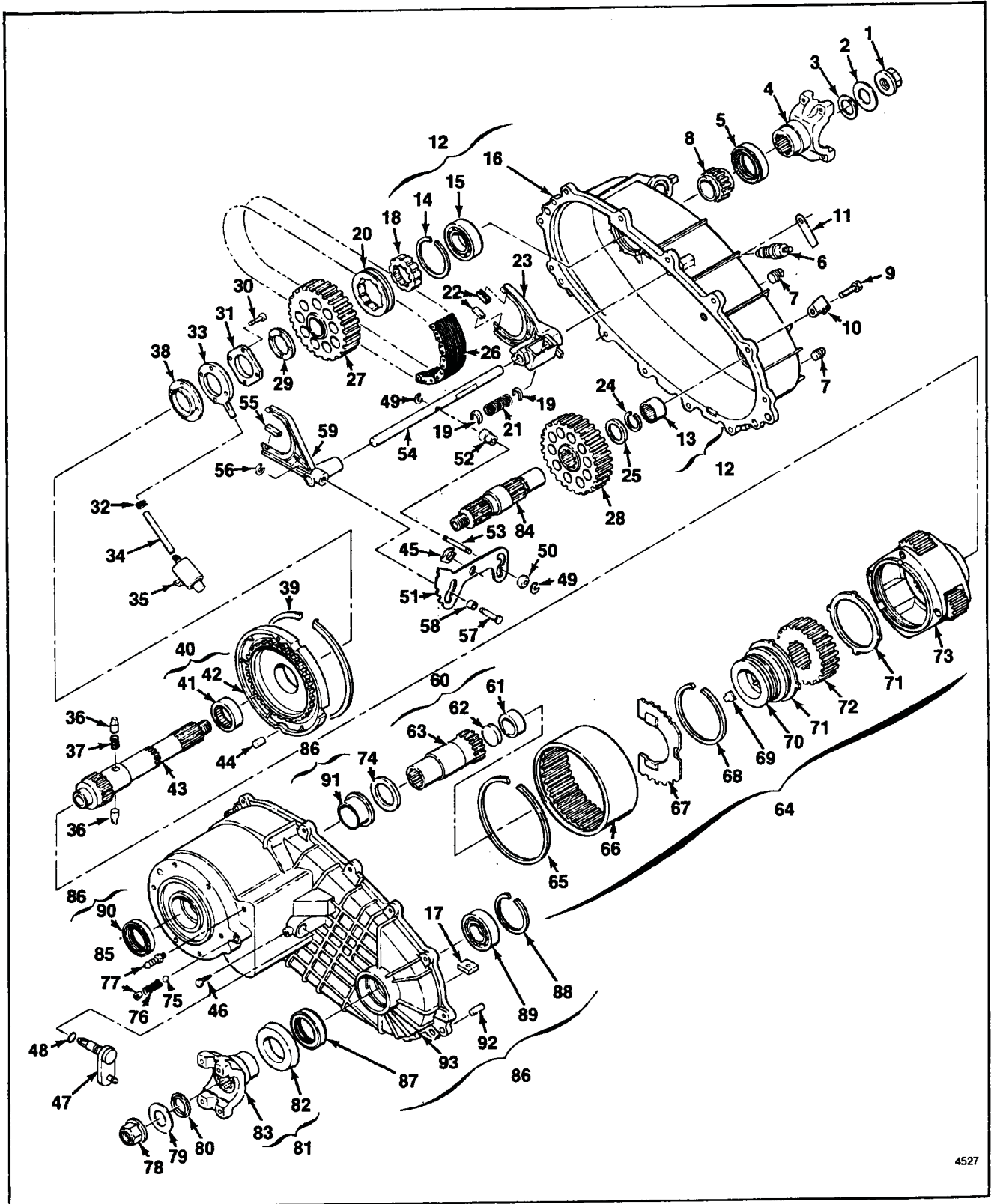

4527

Figure P-1. Transfer Case Assembly PN 13-45-033

PARTS LIST FOR FIGURE P-1

INDEX NO.	PART NUMBER	DESCRIPTION	QTY
1	10-00-149-019	Nut	1
2	10-00-047-015	Washer	1
3	10-00-044-045	Seal, Oil	1
4	13-45-031-003	Yoke (prior to 1/1/89*)	1
	13-45-031-001	Yoke (after 1/1/89*)	1
5	10-00-044-053	Seal, Oil	1
6	13-45-140-001	Switch, 4WD (prior to 1/1/87*)	1
	13-00-140-003	Switch, 4WD (after 1/1/87*)	1
7	0000444576	Plug, Pipe	2
8	13-45-110-006	Gear, Speedo	1
9	13-00-183-018	Bolt	12
10	10-00-056-007	Clip, Wiring	2
11	13-45-199-033	Tag, Identification	1
12	13-45-539-008	Cover Assy, Case	1
13	4840J	● Bearing, Needle	1
14	T86-7-1/2	● Ring, Snap	1
15	13-45-130-001	● Bearing, Ball	1
16	13-45-039-008	● Cover, Case	1
17	10-00-012-002	Magnet	1
18	13-45-090-001	Hub, Shift	1
19	13-45-040-001	Retainer, Spring	2
20	13-45-055-001	Collar, Shift	1
21	13-45-156-006	Spring	1
22	13-45-235-001	Facing, Shift Fork	2
23	13-45-096-004	Fork, Lockup	1
24	13-45-139-004	Ring, Snap	1
25	13-45-193-005	Washer	1
26	13-45-143-002	Chain, Drive, 1¼ in. wide #	1
	13-45-143-001	Chain, Drive, 1½ in. wide #	1
27	13-45-144-005	Sprocket, Drive, 1¼ in. wide #	1
	13-45-144-001	Sprocket, Drive, 1½ in. wide #	1
28	13-45-144-004	Sprocket, Driven, 1¼ in. wide #	1
	13-45-144-002	Sprocket, Driven, 1½ in. wide #	1
29	13-45-193-004	Washer, Thrust	1
30	13-45-183-003	Screw, Cap	4
31	13-45-039-005	Cover, Pump, Rear	1
32	13-45-056-005	Clamp, Hose	1
33	13-45-097-004	Housing, Pump	1
34	13-45-034-006	Coupling, Hose	1
35	13-45-238-001	Filter	1
36	13-45-043-007	Pin, Pump	2
37	13-45-156-004	Spring	1
38	13-45-039-007	Cover, Pump, Front	1
39	13-45-139-006	Ring, Snap	1
40	13-45-607-006	Retainer, Plate and Bearing Assy	1
41	10-00-132-015	● Bearing, Needle	1
42	13-45-607-005	● Retainer and Plate Assy	1
43	13-45-171-003	Shaft, Ouput, Upper	1
44	00001411275	Pin, Dowel	2
45	13-45-056-002	Klip, Ring	1
46	13-45-183-001	Setscrew	1
47	13-45-598-006	Lever Assy, Shift	1
48	T89B-108	O-ring	1
49	13-45-056-001	Ring, Crescent	2
50	13-45-127-004	Roller, Cam	1
51	13-45-099-004	Cam, Shift	1
52	13-45-127-003	Roller, Cam	1
53	13-45-043-006	Pin	1

PARTS LIST FOR FIGURE P-1 (Cont)

INDEX NO.	PART NUMBER	DESCRIPTION	QTY
54	13-45-100-002	Rail, Lockup	1
55	13-45-235-001	Facing, Shift Fork	2
56	13-45-056-003	Clip, Retaining	1
57	13-45-043-001	Pin	1
58	13-45-127-005	Roller, Cam	1
59	13-45-096-005	Fork, Reduction Shift	1
60	13-45-689-003	Shaft Assy, Input (long—supersedes 13-45-689-004)	1
	13-45-689-004	Shaft Assy, Input (short—superseded by 13-45-689-003)	1
61	13-45-127-002	● Bushing	1
62	0009421756	● Plug, Cup	1
63	13-45-189-003	● Shaft, Input (long—supersedes 13-45-189-004)	NP
	13-45-189-004	● Shaft, Input (short—superseded by 13-45-189-003)	NP
64	13-45-659-003	Carrier Assy, Reduction	1
65	13-45-139-002	● Ring, Snap	1
66	13-45-162-002	● Gear, Ring	1
	13-45-162-003	● Gear, Ring (optional)	AR
	13-45-162-004	● Gear, Ring (optional)	AR
	13-45-162-005	● Gear, Ring (optional)	AR
67	13-45-014-003	● Plate, Ring Gear	1
68	13-45-139-001	● Ring, Snap	1
69	13-45-104-001	● Key, Pinion Cage	1
70	13-45-103-002	● Hub, Shift Carrier	1
71	13-45-193-003	● Washer, Thrust	2
72	13-45-165-002	● Gear, Sun	1
73	13-45-659-004	● Planet and Gear Assy	1
74	13-45-193-001	Washer, Thrust	1
75	0000453593	Ball, Steel	1
76	13-45-156-001	Spring	1
77	10-00-113-011	Plug, Cup	1
78	10-00-149-019	Nut	1
79	10-00-047-015	Washer	1
80	10-00-044-045	Seal, Oil	1
81	13-45-531-002	Yoke Assy (Bronco—short wheel base)	1
	13-45-531-003	Yoke Assy (F Series—long wheel base)	1
82	13-45-035-001	● Deflector, Dust	1
83	13-45-031-003	● Yoke (Bronco—short wheel base)	1
	13-45-031-002	● Yoke (F Series—long wheel base)	1
84	13-45-171-002	Shaft, Output, Lower	1
85	13-45-012-001	Barb, Breather Hose	1
86	13-45-565-002	Case Assy, Transfer	1
87	13-45-044-053	● Seal, Oil	1
88	T86-7½	● Ring, Snap	1
89	13-45-130-001	● Bearing, Ball	1
90	13-45-044-054	● Seal, Oil	1
91	13-45-127-001	● Bushing, Input Shaft	1
92	0000141281	● Pin, Dowel	2
93	13-45-065-002	● Case, Transfer	1

*Date of manufacturer—see ID tag (11) and figure 1-1

#Measure width to determine correct replacement part No.

1356

Introduction and Description

1-1. INTRODUCTION

1-2. PURPOSE. This manual contains maintenance, service and parts information for the 13-56 Four-Wheel Drive Transfer Case manufactured by Borg-Warner Automotive, Inc., Transmission Systems, P.O. Box 2688, Muncie, IN 47307.

1-3. SCOPE. As you will see in the Table of Contents, this manual provides information for maintenance, troubleshooting, installation, removal, disassembly, cleaning, inspection, repair or replacement, and assembly of the transfer case.

1-4. Section P of the manual contains an illustrated parts list. The arrangement of the exploded view illustrations is described in the introduction to Section P. Each detail part shown in the exploded views is assigned an index number. This same index number is used to identify the part throughout this manual. For example, index number 53 (in parentheses in the text) refers to the drive chain regardless of the manual section or the specific model transfer case being serviced.

1-5. The exploded view illustrations in Section P make it possible to view the complete assembly in addition to the illustrations in the service sections relating to a specific service procedure.

1-6. Section T lists special tools. These tools, or equivalent are required for proper disassembly and assembly of the transfer case.

1-7. ABBREVIATIONS. Abbreviations, other than those in common use, found in this manual are identified in Table 1-1.

Table 1-1. Abbreviations

AR	As Required
Assy	Assembly
ID	Inside Diameter
NP	Not Procurable
OD	Outside Diameter
PN	Part Number
PR	Per
Qty or QY	Quantity
Ref	Reference
TIR	Total Indicator Reading

1-8. DESCRIPTION

1-9. TRANSFER CASE DESCRIPTION. The Borg-Warner Automotive 13-56 is a two-speed, part time transfer case. A planetary gear set is used to provide gear reduction. Power is transferred to the front wheel drive through a Morse Hy-Vo® chain drive. The unit operates in an oil bath plus an oil pump is used to provide positive lubrication to the planetary gear set and other upper shaft components. Four selector positions are provided:

2H — In two high position, only the two rear wheels are driven and the transfer case operates at a 1.00 to 1.00 speed ratio.

4-H — In four high, all four wheels are driven at a 1.00 to 1.00 speed ratio.

N — **MECHANICAL SHIFT UNITS ONLY.** In the neutral position, the output shaft is disconnected from the input shaft and no power is transmitted to the wheels.

4L — In four low, all four wheels are driven and the transfer case operates at a 2.69 to 1.00 speed reduction ratio.

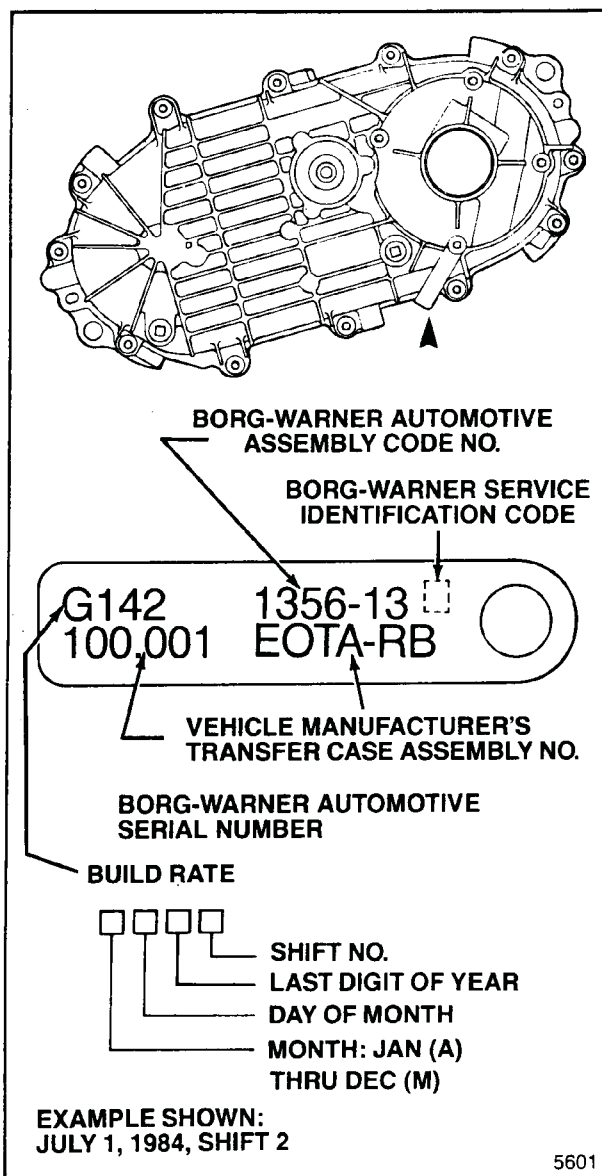

Figure 1-1. Identification Tag

1-10. SHIFTING. The 13-56 mechanical shift transfer case is controlled by a single shift lever that operates a shift cam within the transfer case. Additional components are installed on the 13-56 electric shift transfer case: an electric clutch, a speed sensor and an electric motor to drive the shift cam within the case. A separate electronic shift control system is also necessary (refer to vehicle manual). The clutch is used to spin up the front drive system and permit shifting from 2H to 4H at any speed. The speed sensor provides information to the electronic control system to regulate shifting from 4H to 4L.

1-11. APPLICATION. The 13-56 transfer case is used for light truck applications.

1-12. IDENTIFICATION. The identification tag is installed on the transfer case at the location shown in figure 1-1, looking at the rear of the case. Figure 1-1 also illustrates the information to be found on the tag, some of which may be necessary for specifying correct replacement parts. Figure 1-1 also shows the alternate identification marking location which contains the same information.

1-13. PART NUMBER VARIATIONS. This manual covers several variations of the 13-56 transfer case. These are defined by the last three digits of the part number and described in Table 1-2.

Table 1-2. 13-56-000-XXX Part Number Definitions

1987	1988	1989	1989-1/2	SPEEDO	DESCRIPTION
-016** -012**	-027 -024	-027/-032* -024/-031*		7 tooth 8 tooth	Mechanical shift with rear yoke
-017 -013	-017 -013	-017/-030* -013/-029*		7 tooth 8 tooth	Electric shift with rear yoke
			-040 -039	7 tooth 8 tooth	Mechanical shift with rear flange
			-038 -037	7 tooth 8 tooth	Electric shift with rear flange
-004** -007**	-025 -023	-025/-034* -023/-033*	-034* -033*	7 tooth 8 tooth	Mechanical shift with rear spline
-008**	-026 -028	-026/-035* -028/-036*	-035* -036*	7 tooth 8 tooth	Mechanical shift with rear spline and PTO

**Units with offset design mechanical shift lever. Interchangeable with later model years if lever is changed.

* 1989 model year units are interchangeable with 1988 model year units. For example, 13-56-000-032 can be interchanged with 13-56-000-027.

On-Vehicle Service and Troubleshooting

2-1. MAINTENANCE

2-2. GENERAL. The only periodic maintenance required for the Borg-Warner Automotive 13-56 transfer case is to maintain proper lubrication.

2-3. LUBRICATION SCHEDULE. Refer to Table 2-1.

2-4. APPROVED LUBRICANT. Use only automatic transmission fluid, Dexron® II, XT-2-QDX (Ford ESP-M2C138-CJ) or equivalent in the transfer case.

NOTE: To check or drain the lubricant, the transfer case should be warm. This is best done shortly after shutdown.

2-5. CHECKING LUBRICANT LEVEL.

CAUTION

Do not use an impact wrench to remove or install fill or drain plugs since this will damage female threads in transfer case cover.

- Wipe fluid level plug (see figure 2-1) and surrounding area clean.
- Remove fluid level plug (7L).
- When transfer case is full, lubricant will just drip out fluid level plug opening.
- Add approved lubricant (refer to paragraph 2-4) if required.
- Install fluid level plug and torque to 7-17 lb-ft (9-23 Nm).

2-6. CHANGING LUBRICANT.

- Wipe fluid level and drain plugs (see figure 2-1) and surrounding areas clean.
- Place suitable container under transfer case. Transfer case holds approximately 4.0 US pints when full.
- Remove drain plug (7D).
- Remove fluid level plug (7L).
- Allow all lubricant to drain.
- Install drain plug and torque to 7-17 lb-ft (9-23 Nm).
- Add approved lubricant (paragraph 2-4) approximately 4.0 US pints) through fluid level plug opening until lubricant just begins to drip back out of opening.

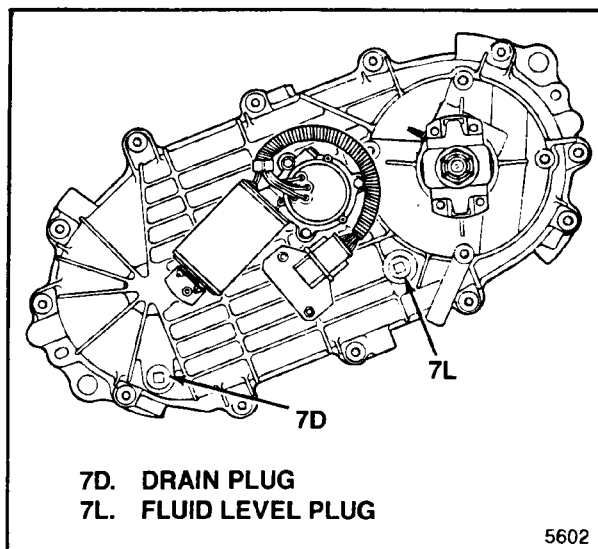

Figure 2-1. Drain and Fluid Level Plugs

- Install fluid level plug and torque to 7-17 lb-ft (9-23 Nm).

2-7. TROUBLESHOOTING

2-8. GENERAL. In the event of operating difficulty, it is recommended that the transfer case (engine) be shut down. In most cases, to accurately pinpoint the source of trouble, it may be necessary to remove and disassemble, or partially disassemble, the transfer case. Specific inspection procedures for detail parts of the transfer case are provided in Section 4.

2-9. TROUBLESHOOTING CHART. Table 2-2 lists troubles which may be encountered along with possible causes and remedies.

Table 2-1. Lubrication Schedule

FREQUENCY	PROCEDURE
With each engine oil change	Check transfer case lubricant level
Yearly or after every 30,000 miles, whichever comes first	Change transfer case lubricant

TROUBLE	POSSIBLE CAUSE	REMEDY
Electric shift problems (shift can be operated manually after motor is removed)	Damaged or defective control console component, electronic control module, speed sensor, electric shift motor electric clutch or interconnecting wiring	Refer to vehicle manual for diagnosis and test procedure to isolate faulty component or components. Replace as required
Electric shift problems (will not shift manually after motor is removed)	Damaged or worn shift cam, hub, collar, fork or rail shaft	Disassemble and check for worn or damaged parts. Replace as required
	Shift fork, hub collar or gears binding	Disassemble and check that sliding parts move freely. Replace as required.
No mechanical shift (control lever moves)	Control lever or shift linkage broken or damaged	Replace damaged parts
	Damaged shift cam; broken shift fork	Remove transfer case cover and check for damaged parts. Replace damaged parts
Hard mechanical shift or control lever will not move into position	Improper operation	Refer to vehicle operator's manual for specific operating sequence, if any
	Improper or low transmission lubricant	Add or drain and replace with proper lubricant (refer to paragraph 2-4)
	Shift fork binding	Remove transfer case cover and check for damaged parts. Replace damaged parts
	Binding of sliding shift hub, collar or gears	Remove transfer case cover, reach down into transfer case and check that sliding parts (parts with shifting grooves) slide freely on shaft. Remove and replace damaged parts
Mechanical shift jumps out of engagement	Damaged or improperly adjusted shift linkage	Adjust or repair shift linkage
	Internal shift parts damaged or excessively worn	Disassemble and check for worn or damaged parts. Replace damaged parts
	Shifting fork loose on rail or damaged	Disassemble and check for wear or damage. Replace worn or damaged parts
Mechanical shift locked in one position	Damaged or improperly adjusted shift linkage	Adjust or repair shift linkage
	Fork loose on rail	Remove transfer case cover and check for loose fork on rail. Replace parts as required.
	Worn or damaged fork, shift cam, gears, hub or collar	Remove transfer case cover and check for wear or damage. Replace damaged parts

Table 2-2. Troubleshooting Chart (Cont)

TROUBLE	POSSIBLE CAUSE	REMEDY
Transfer case noise in all modes of operation. NOTE: Make sure noise is coming from transfer case and not clutch, transmission, drive shaft or other components	Improper or low transfer case lubricant	Add or drain and replace with proper lubricant (refer to paragraph 2-4)
	Loose bolts or other attaching parts	Make sure all attaching parts are torqued to specifications
	Noisy transfer case bearings	Disassemble and check bearings and parts in and on which they operate for wear or damage. Replace worn or damaged parts
	Noisy gears	Disassemble and check for worn or damaged parts (including speedometer gear). Replace worn or damaged parts
Transfer case noise in 4WH or 4WL	Worn or damaged sprockets or drive chain	Disassemble and check for worn or damaged parts and replace as required
	Incorrect tire pressure	Inflate all tires to manual specifications
Transfer case leakage	Cracked case	Replace case. Torque bolts and plugs to specifications.
	Leakage from other components	Verify transfer case leakage. Thoroughly clean, operate and check for leaks
	Breather clogged	Remove breather hose and breather and clean or replace
	Too much or improper lubricant	Remove fluid level plug to check for excess, or drain and replace
	Improperly applied sealant	Replace and torque bolts to specifications
	Worn or damaged oil seal	Replace oil seal
	Loose bolts at sealing faces	Torque bolts to specifications

Table 2-2. Troubleshooting Chart (Cont)

TROUBLE	POSSIBLE CAUSE	REMEDY
No front wheel drive with control in four wheel drive	Broken drive chain	Disassemble, check all internal parts for damage, replace drive chain
Transfer case does not disengage 4WH after 2WD is selected (electric or mechanical shift)	Incorrect tire pressure	Inflate all tires to manual specifications 1
	Unevenly worn tires	Rotate tires
	Mismatched front and rear axle tire sizes	Install same tires on all wheels
	Shift fork binding	Remove transfer case and check for damaged parts. Replace damaged parts
	Fork return spring damaged or worn	Remove transfer case and check spring. Replace if worn or damaged

2-10. REMOVAL AND INSTALLATION

2-11. REMOVAL OF TRANSFER CASE. Refer to the vehicle service manual for specific instructions regarding supports, skid plates, shift linkage, wiring harness, speedometer cable, power take-off and other components related to the transfer case installation. These may need to be removed to provide access to the transfer case. A suitable hoist for the vehicle and a jack or stand for the transfer case will be required. The jack or stand must be capable of completely and independently supporting the transfer case. It also must be able to lower, raise and move the transfer case laterally. Proceed as follows (see figure 2-2):

- a. Position vehicle over suitable hoist.
- b. Shift transmission into park or neutral. Shift transfer case into 2 H and shut off engine.
- c. Disconnect negative battery terminal.
- d. Lift vehicle.
- e. Place drain pan under transfer case and remove transfer case drain (7D) and fluid level (7L) plugs (see figure 2-1). Drain all fluid from transfer case and re-install plugs.
- f. Disconnect all electrical wiring and/or wiring harnesses from transfer case.
- g. On mechanical shift units, disconnect shift linkage from transfer case shift lever (77).
- h. Disconnect speedometer cable from transfer case

bearing cap (14).

i. Disconnect breather hose from transfer case breather barb (98).

j. Disconnect front driveshaft from transfer case front yoke (96).

k. Disconnect rear driveshaft from transfer case rear yoke (6) or spline.

l. Support transfer case with suitable jack or stand.

CAUTION

Make sure transfer case is completely supported by jack or stand before removing bolts (201) attaching transfer case to transmission. Do not allow transfer case to "hang" from transmission through splined shafts or damage may result.

m. Remove six bolts (201) attaching transfer case to transmission adapter (202).

n. Move transfer case straight back to completely disengage spline of transfer case input shaft (87) from transmission.

o. Carefully lower transfer case on jack or stand.

p. Remove gasket (203) used between transmission and transfer case.

2-12. INSTALLATION OF TRANSFER CASE.

Refer to the vehicle service manual for specific instructions regarding supports, skid plates, shift linkage, wiring harness, speedometer cable, power take-off and other components which were removed to provide access to transfer case. With vehicle on hoist and transfer case on a suitable jack or stand, proceed as follows (see figure 2-2):

a. Apply thin coat of high temperature grease to spline of transmission output shaft.

b. Install new gasket (203) on mounting face of transfer case.

c. Raise transfer case on jack or stand and align with transmission.

CAUTION

Make sure transfer case is in exact alignment with transmission before engaging splines. Do not force transfer case onto transmission. Otherwise, damage may result. If necessary, turn rear output shaft of transfer case to align input shaft (87) spline with that on transmission.

d. Carefully move transfer case forward, engaging spline on transmission and dowel pin, until mounting face of transfer case (110), gasket (203) and transmission adapter (202) are in contact.

e. Make sure mounting holes in transfer case (110), gasket (203) and transmission adapter (202) are aligned and install six mounting bolts (201). Torque mounting bolts to 25-43 lb-ft (34- 58 Nm) in sequence shown in figure 2-2.

f. Connect rear driveshaft to transfer case rear yoke (6) or spline.

g. Connect front driveshaft to transfer case front yoke (96).

h. Connect breather hose to transfer case breather barb (98).

i. Connect speedometer cable at transfer case bearing cap (14).

j. On mechanical shift units, connect shift linkage to transfer case shift lever (77).

k. Connect all wiring and/or wiring harnesses to transfer case.

l. Fill transfer case with approved lubricant as described in paragraph 2-6.

CAUTION

Failure to fill transfer case to proper level with approved lubricant will result in damage when engine is started.

NOTE

Use of pump type filler may be necessary when filling transfer case installed on vehicle.

NOTE

If transfer case has been removed for repair or overhaul, there will be no lubricant in upper cavities served by transfer case pump. Lubricant level at fluid level plug opening will not be accurate until pump is operated and these cavities are filled. This can be done on hoist if wheels are free or by driving. Recheck lubricant level after operating pump.

m. After final check of lubricant level, lower vehicle and connect negative battery terminal.

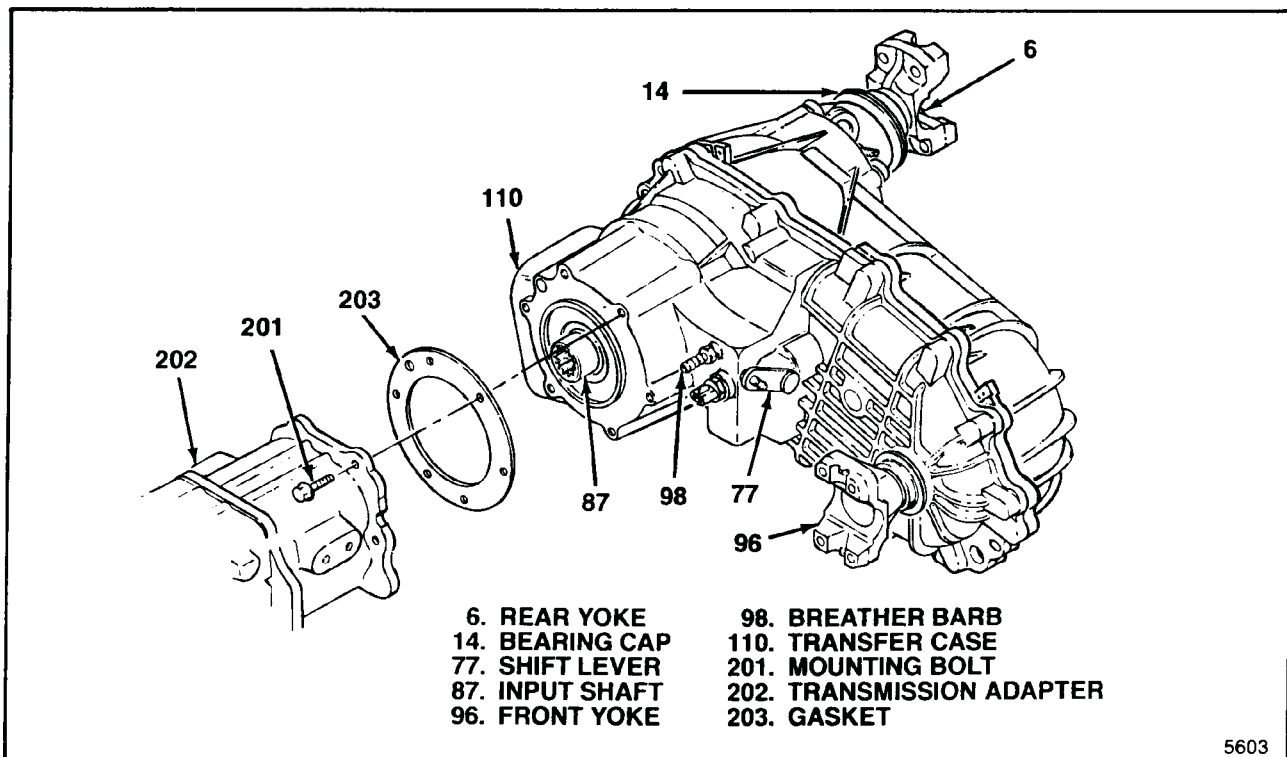

5603

Figure 2-2. Transfer Case Installation

Disassembly

3-1. GENERAL INFORMATION

3-2. During disassembly, refer to the illustrations provided with the text. In addition, an exploded view of the complete assembly can be seen in Section P, Parts.

3-3. This section provides instructions for complete disassembly of the transfer case as would be required for overhaul. If the transfer case is not due for overhaul, and repair affecting specific parts is required, disassemble only to the extent necessary to gain access to these parts. Parts removed from the transfer case as subassemblies or groups need not be disassembled for repair unless they contain the affected parts.

3-4. REMOVAL AND INSTALLATION OF TRANSFER CASE

3-5. Refer to paragraph 2-10.

3-6. TRANSFER CASE DISASSEMBLY

3-7. **REMOVAL OF REAR YOKE OR FLANGE GROUP.** Position transfer case on work bench with rear or cover side up. Use wooden blocks under front to keep assembly level. Proceed as follows (see figure 3-1):

- a. Remove nut (1) and washer (2).
- b. Pull yoke or flange assembly (4) and remove oil seal (3).
- c. Press deflector (5) from yoke or flange (6) only if replacement is required.

3-8. REMOVAL OF BEARING CAP OR EXTENSION GROUP (See figure 3-2 for rear yoke or flange; figure 3-3 for rear spline).

- a. If installed, remove two plugs (7).
- b. Remove four bolts (8) attaching bearing cap or extension assembly (9) to cover (35). This will free identification tag (111). Use care not to lose identification tag. It contains information that may be required for ordering replacement parts.
- c. Pull oil seal (10) from bearing cap or extension (14).
- d. For rear spline units, press bushing (11) out of extension (14).
- e. Remove stud bolt (13) and speedo plate (12).

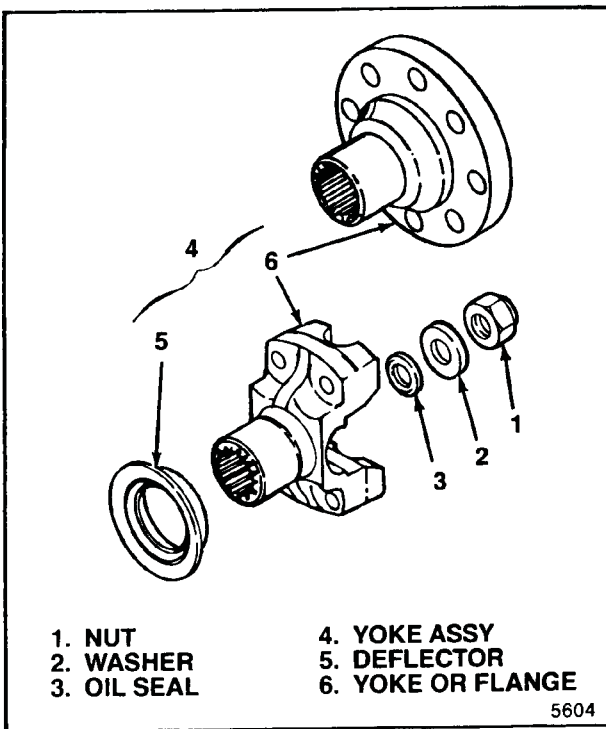

Figure 3-1. Rear Yoke Or Flange Group

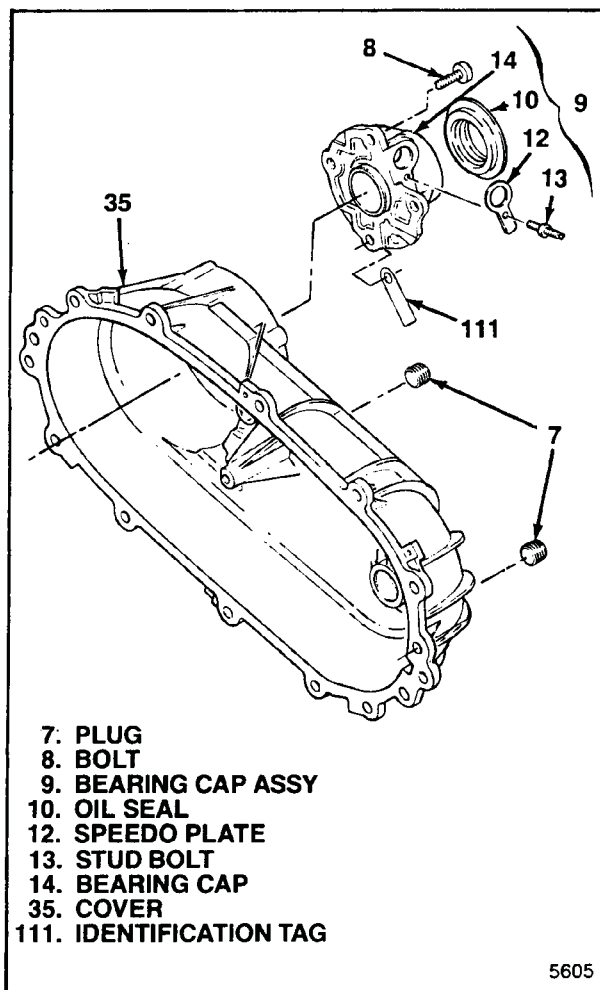
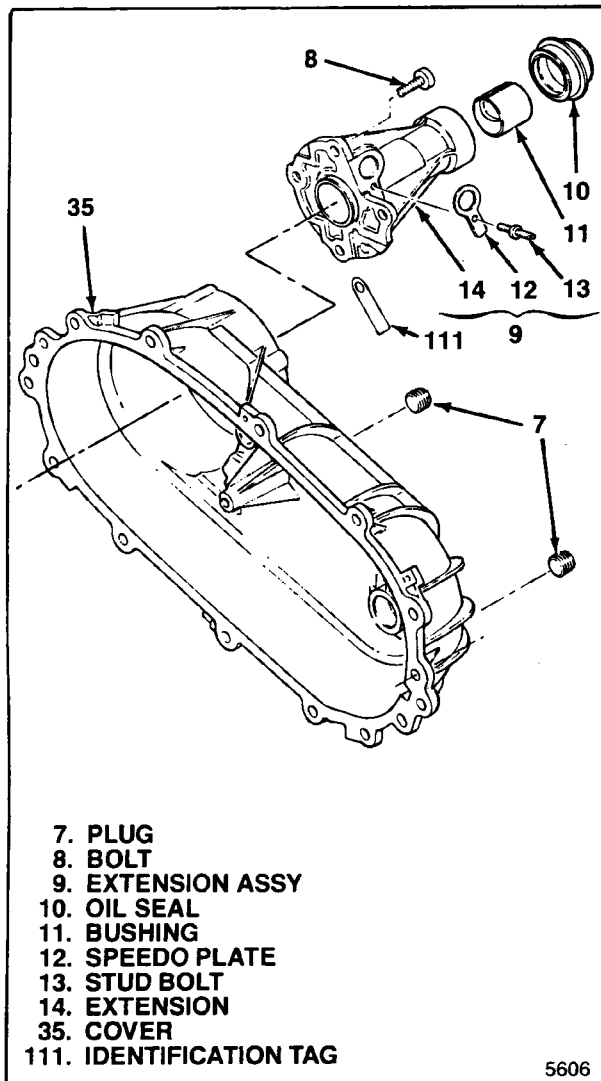

Figure 3-2. Bearing Cap Group (Rear Yoke or Flange)



- 7. PLUG
- 8. BOLT
- 9. EXTENSION ASSY
- 10. OIL SEAL
- 11. BUSHING
- 12. SPEEDO PLATE
- 13. STUD BOLT
- 14. EXTENSION
- 35. COVER
- 111. IDENTIFICATION TAG

5606

Figure 3-3. Extension Group (Rear Spline)

3-9. REMOVAL OF EXTERNAL ELECTRIC SHIFT COMPONENTS (ELECTRIC SHIFT TRANSFER CASE ONLY) (See figure 3-4). On electric shift units, remove components as follows:

- a. Remove bolts (15 through 17).
- b. Remove wiring harness bracket (18) and sensor and o-ring assembly (19). Remove o-ring (21) from speed sensor (20).
- c. Remove motor assembly (22).

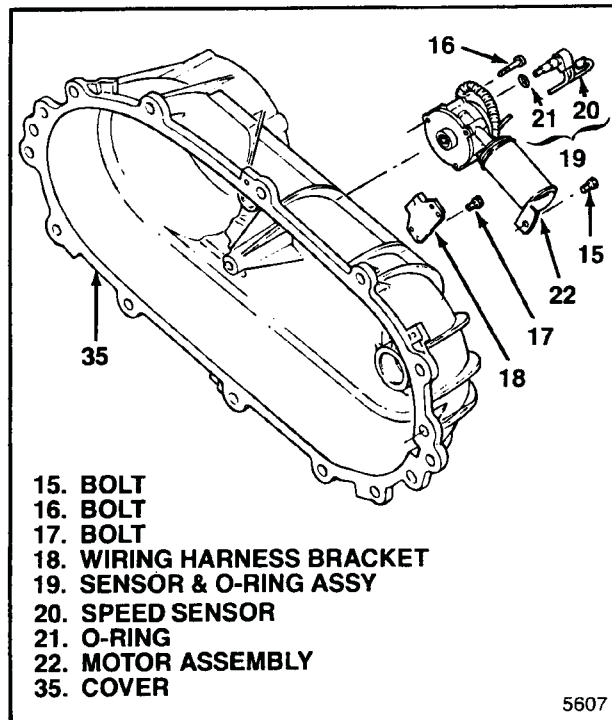

- 15. BOLT
- 16. BOLT
- 17. BOLT
- 18. WIRING HARNESS BRACKET
- 19. SENSOR & O-RING ASSY
- 20. SPEED SENSOR
- 21. O-RING
- 22. MOTOR ASSEMBLY
- 35. COVER

5607

Figure 3-4. External Electric Shift Components

3-10. REMOVAL AND DISASSEMBLY OF COVER ASSEMBLY. Proceed as follows (see figure 3-5 for electric shift; figure 3-6 for mechanical shift):

- a. Unsnap speedo gear retainer (23) from output shaft (65).
- b. Slide speedo gear (25) inward and remove ball (24) from detent in output shaft (65). This will free speedo gear (25).
- c. Remove snap ring (26) from output shaft (65).
- d. Remove twelve bolts (27). Pry at bosses provided on cover (35) and transfer case (110) to break sealant bond loose. Then, lift the cover assembly (28) straight up to remove.
- e. Pull ball bearing (29) from cover (35).
- f. Pull needle bearing (30) from cover (35).
- g. From electric shift units, pull oil seal (31) and sleeve bearing (32). Remove three nuts (33) and clutch coil assembly (34).
- h. Scrape and clean sealant from mating faces of cover (35) and transfer case (110). Use care not to damage metal faces.
- i. Remove magnet (36) from slot in case (110).
- j. Remove return spring (37) from shift rail (46).
- k. Remove snap ring (38) from output shaft (65).
- l. From electric shift units, remove clutch housing (39).

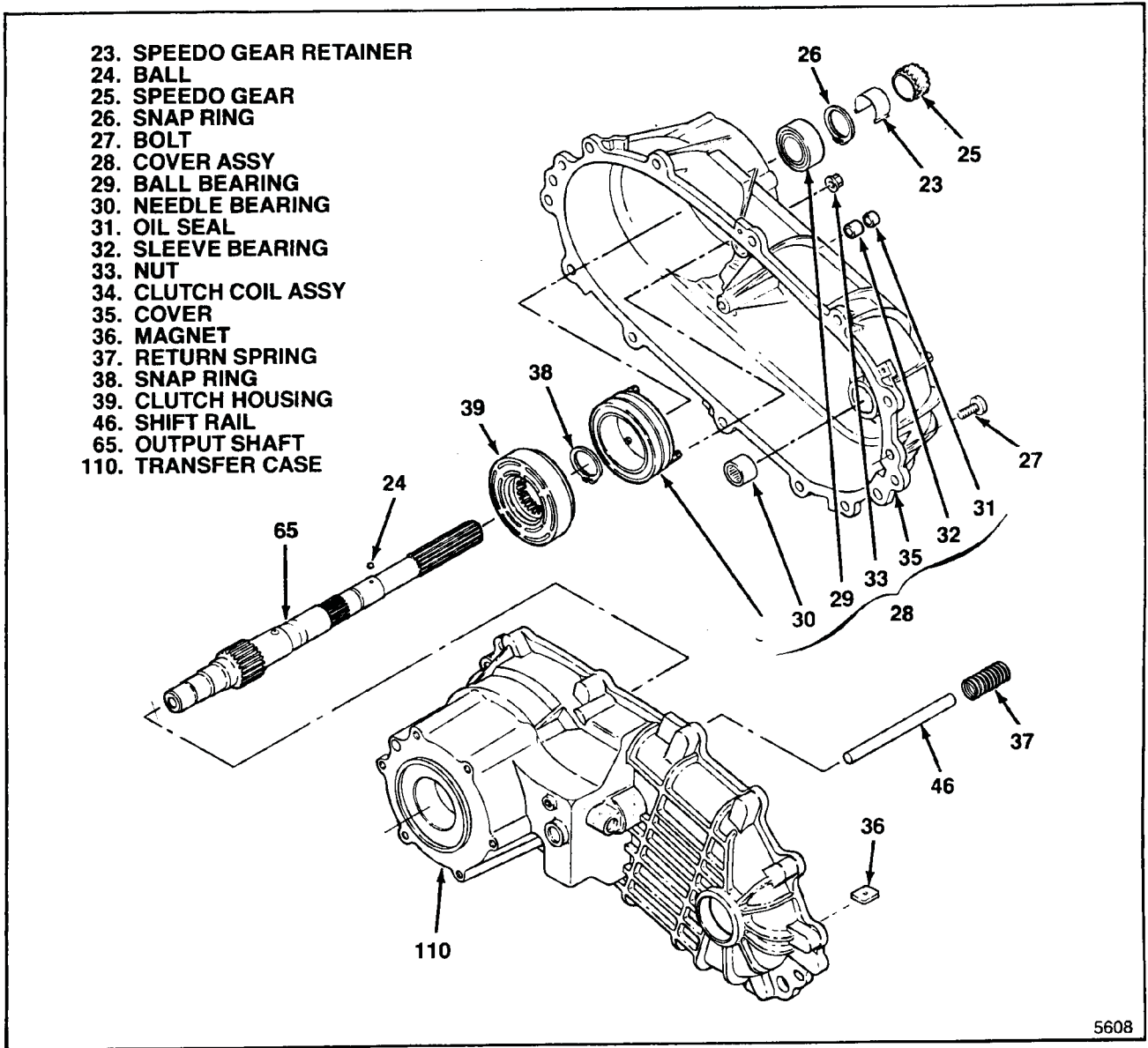

5608

Figure 3-5. Cover Assembly (Electric Shift)

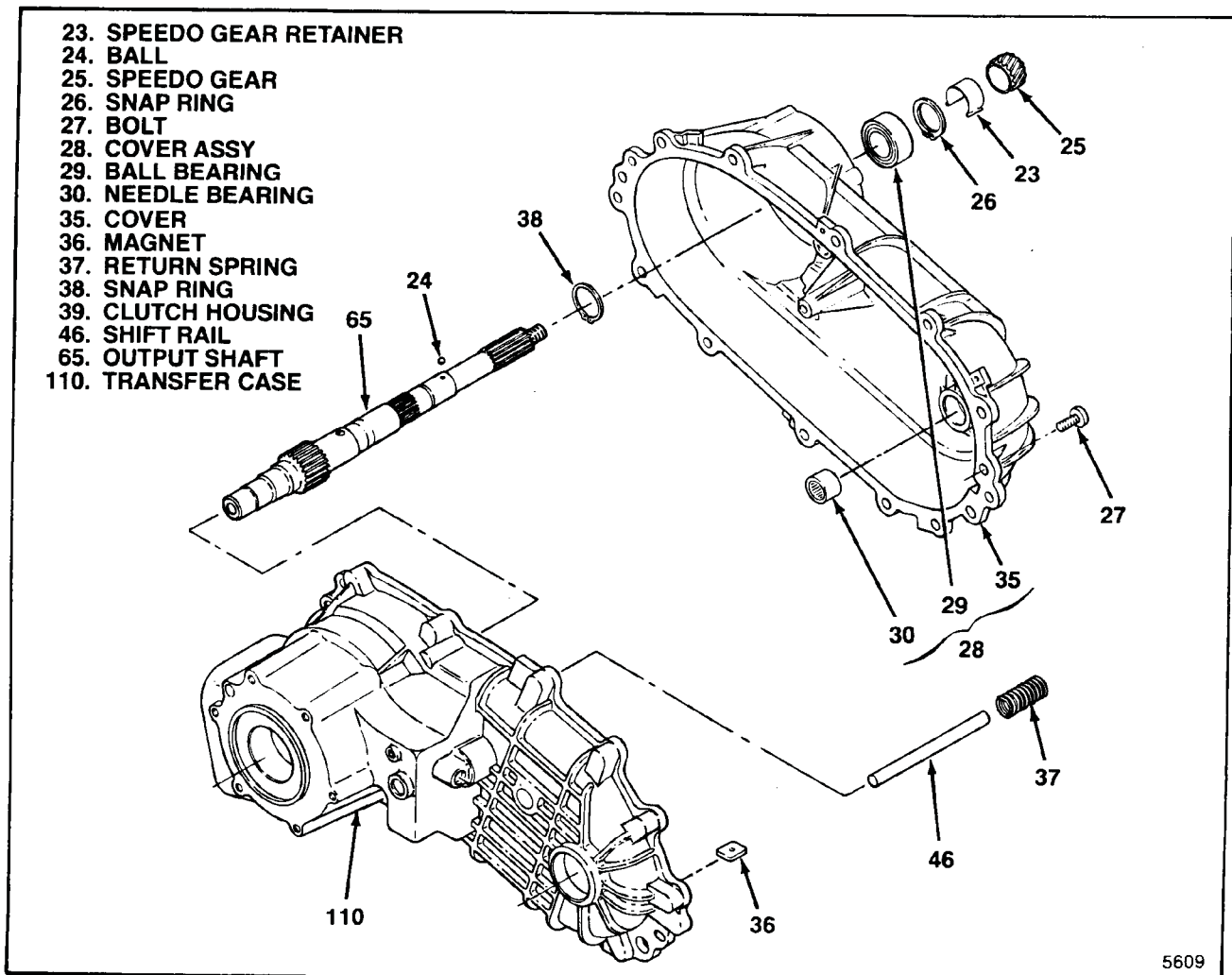

Figure 3-6. Cover Assembly (Mechanical Shift)

3-11. REMOVAL OF LOCKUP SHIFT PARTS.

From remaining transfer case assembly (40 through 110), remove the following (see figure 3-7) for electric shift; figure 3-8 for mechanical shift):

a. Remove shift collar hub (40) from output shaft (65).

b. Together, slide 2W-4W lockup assembly (41) and 2W-4W shift fork assembly (47) from output shaft (65) and shift rail (46). Separate assemblies, remove shift rail (46) and remove two fork facings (48) from fork assembly (47).

c. To disassemble 2W-4W lockup assembly, remove retaining ring (42), lockup hub (43) and spring (44) from lockup collar (45).

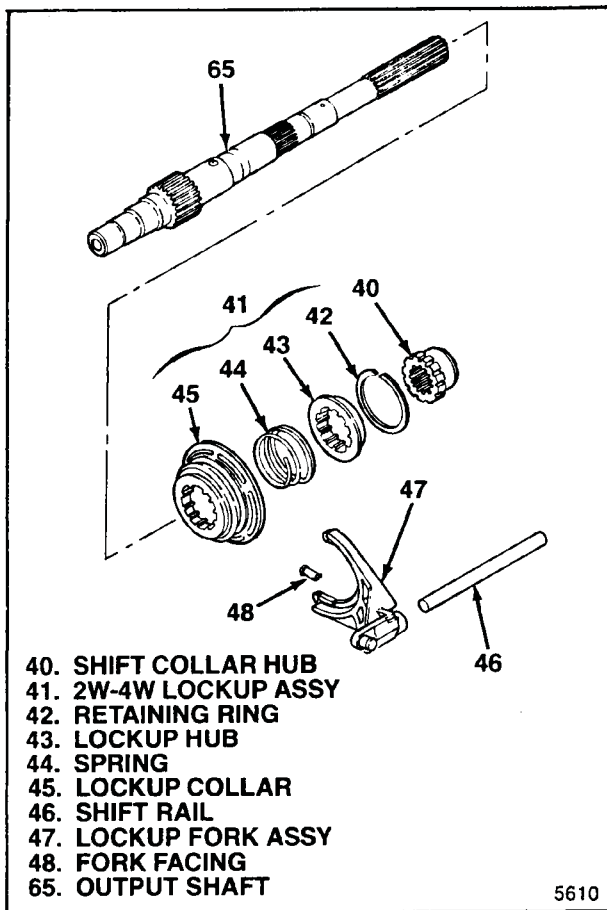

Figure 3-7. Lockup Shift Parts (Electric Shift)

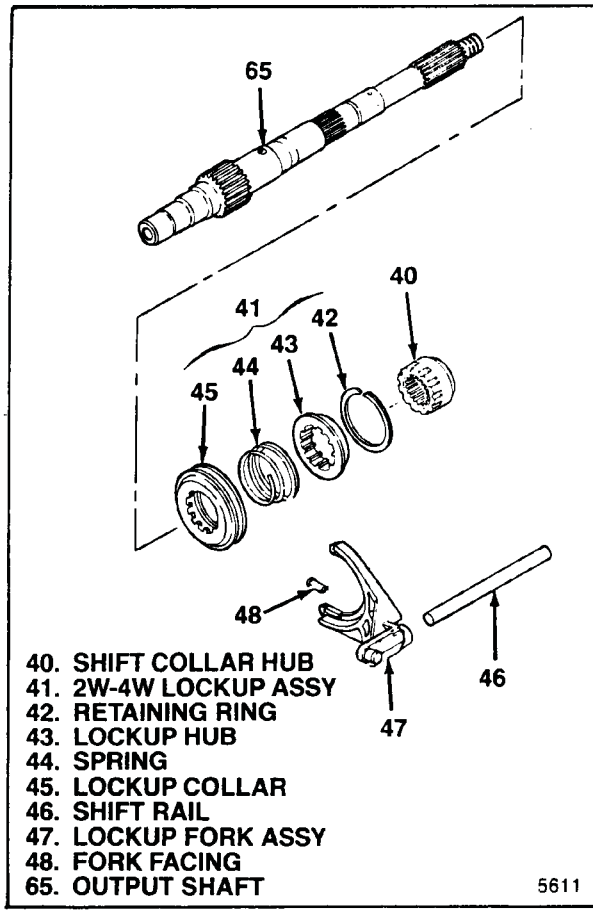

Figure 3-8. Lockup Shift Parts (Mechanical Shift)

3-12. REMOVAL OF CHAIN DRIVE. From remaining transfer case assembly (49 through 110), remove the following (see figure 3-9):

a. Remove retaining ring (49) and washer (50) from output shaft (97).

b. Together, slide drive sprocket (51), driven sprocket (52) and drive chain (53) from output shafts (65 and 97). Separate sprockets and chain when out of assembly.

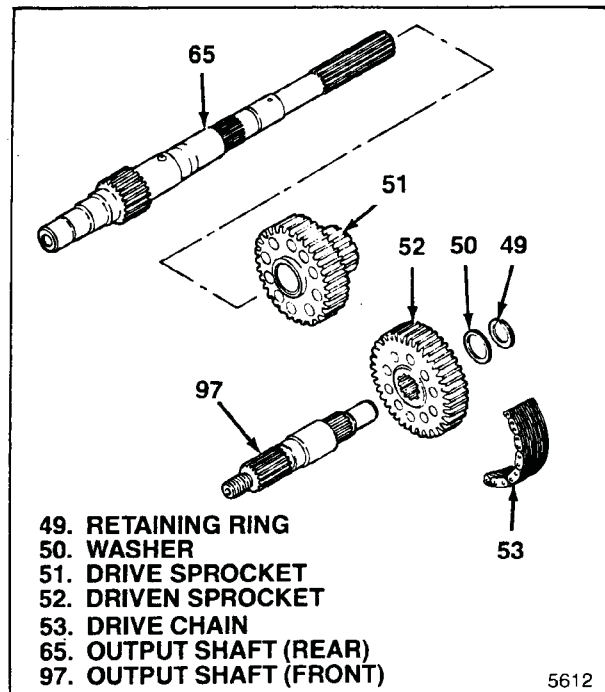

Figure 3-9. Chain Drive

3-13. REMOVAL AND DISASSEMBLY OF SHAFT AND OIL PUMP ASSEMBLY. From remaining transfer case assembly (54 through 110) remove the following (see figure 3-10):

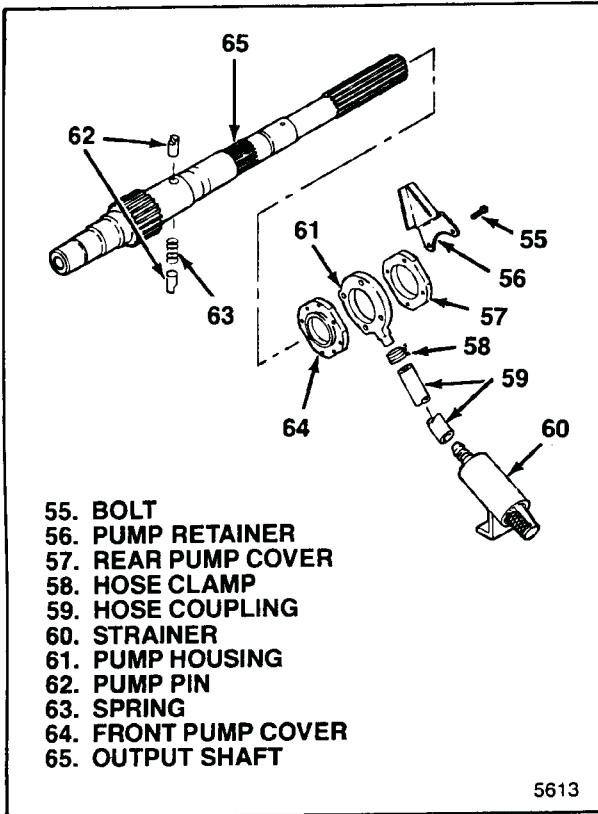

Figure 3-10. Pump Parts

- Remove four bolts (55) and retainer (56). Slide rear pump cover (57) off output shaft (65).
- Loosen hose clamp (58) and separate hose coupling (59) from pump housing (61). Slide pump housing off output shaft (65).
- Remove hose clamp (58), hose coupling (59) and strainer (60).
- Remove two pump pins (62) and spring (63) from output shaft (65).
- Slide front pump cover (64) off output shaft (65). Remove output shaft.

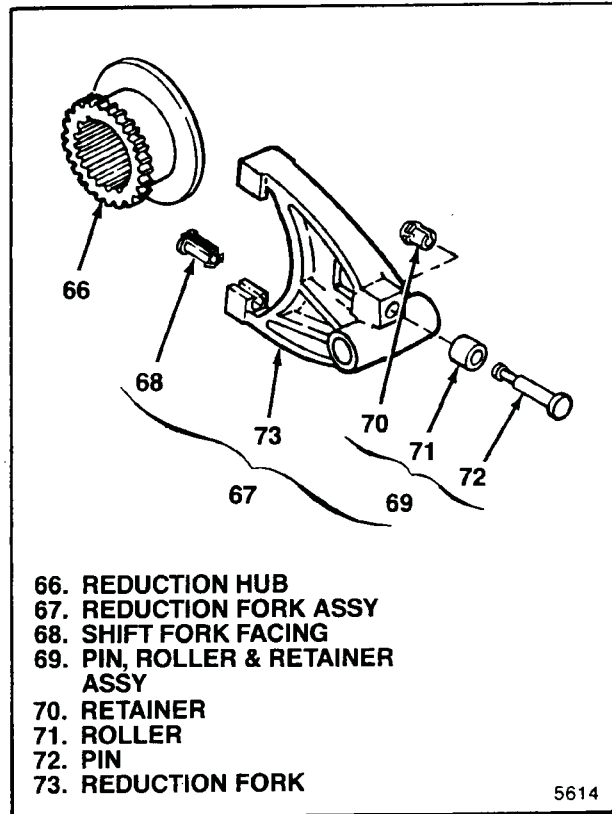

Figure 3-11. Reduction Shift Parts

3-14. REMOVAL OF REDUCTION SHIFT PARTS. From remaining transfer case assembly (66 through 110), remove the following (see figure 3-11):

- Remove reduction hub (66) and reduction shift fork assembly (67) from transfer case.
- Remove two facings (68) from shift fork assembly (67).
- Remove pin, roller and retainer assembly (69) from reduction fork (73) only if damaged. To remove, cut off lip of plastic retainer (70) that projects through fork (73). Remove and discard roller (71) and pin (72) as well as retainer.

3-15. REMOVAL OF SHIFT CAM PARTS (ELECTRIC SHIFT TRANSFER CASE ONLY). On electric shift units, remove the following (see figure 3-12):

- Remove electric shift cam group (81 through 84) from transfer case as an assembly.
- Slide electric shift cam (81) off shift shaft (84).
- Clamp retainer end of shift shaft (84) in soft-jawed vise. Keeping fingers away from spring ends, pry torsion spring (82) out of engagement with shaft drive tang using a screwdriver. Remove torsion spring and spacer (83) from shift shaft.

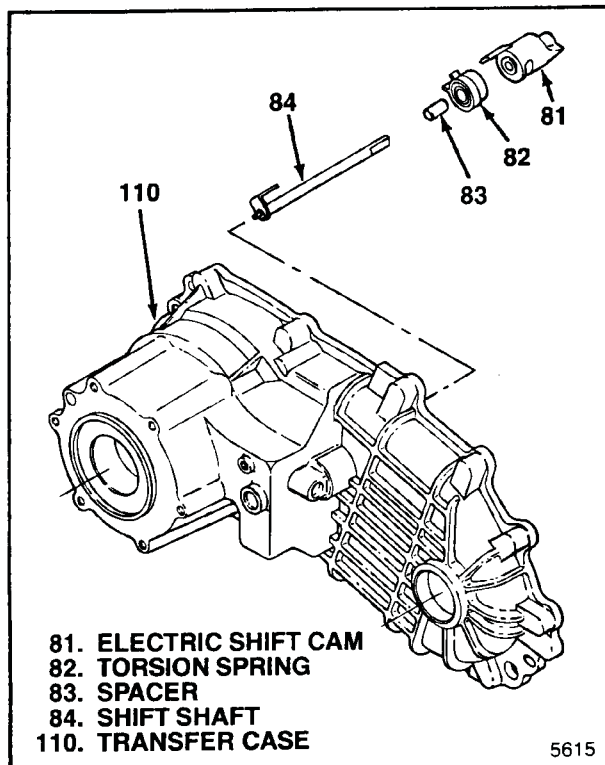

81. ELECTRIC SHIFT CAM
82. TORSION SPRING
83. SPACER
84. SHIFT SHAFT
110. TRANSFER CASE

5615

Figure 3-12. Electric Shift Cam Parts

3-16. REMOVAL OF SHIFT CAM PARTS (MECHANICAL SHIFT TRANSFER CASE ONLY). On mechanical shift units, remove the following (see figure 3-13):

- Remove 4WD indicator (74). Through opening in transfer case (110) loosen setscrew (75) in shift cam (80).
- Remove klip ring (76) and lever, shaft and pin assembly (77).
- Remove assist spring (78) and assist bushing (79).
- Remove shift cam (80) from transfer case (110).

3-17. REMOVAL OF CARRIER ASSEMBLY AND RING GEAR. From remaining transfer case assembly (85 through 110), remove the following (see figure 3-14):

- Pull oil seal (85) from transfer case (110).
- Remove retaining ring (86) from input shaft of carrier assembly (87).

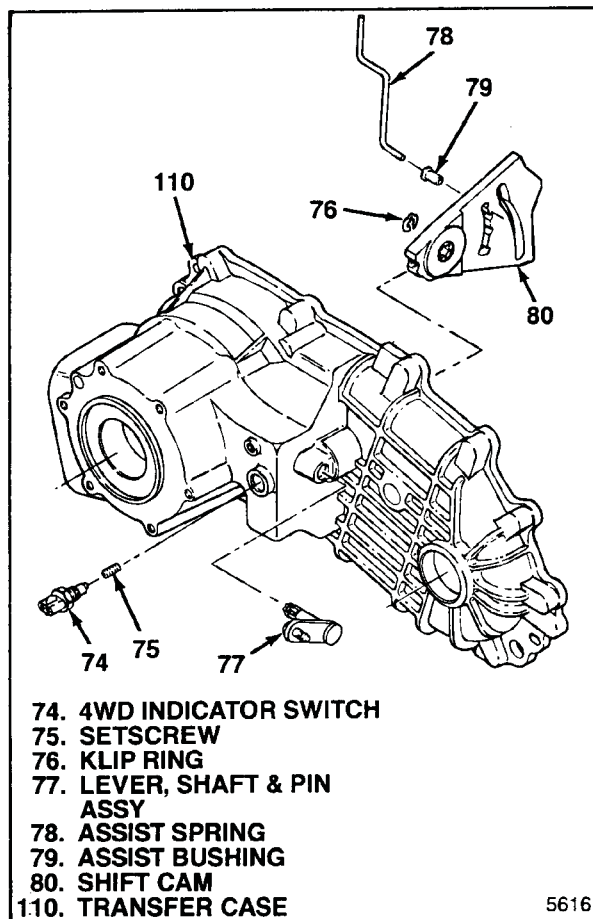

74. 4WD INDICATOR SWITCH
75. SETSCREW
76. KLIP RING
77. LEVER, SHAFT & PIN
ASSY
78. ASSIST SPRING
79. ASSIST BUSHING
80. SHIFT CAM
110. TRANSFER CASE

5616

Figure 3-13. Mechanical Shift Cam Parts

- Remove carrier assembly (87) from transfer case (110).
- Remove retaining ring (88) and pull ring gear (89) from transfer case (110).
- On mechanical shift units with PTO, remove PTO gear (90).

3-18. REMOVAL OF FRONT OUTPUT SHAFT GROUP. From remaining transfer case assembly (91 through 110), remove the following (see figure 3-15):

- Remove nut (91) and washer (92).
- Pull yoke assembly (94) and remove oil seal (93).
- Press deflector (95) from yoke (96) only if replacement is required.
- Remove output shaft (97) from transfer case (110).

3-19. DISASSEMBLY OF TRANSFER CASE ASSEMBLY. Disassemble as follows (see figure 3-16):

- Remove breather barb (98).
- On units with PTO, remove bolts (99), PTO cover (100) and gasket (101).
- Pull oil seal (103).
- Remove retaining ring (104) and pull ball bearing (105).
- Remove retaining ring (106) and pull ball bearing (107).

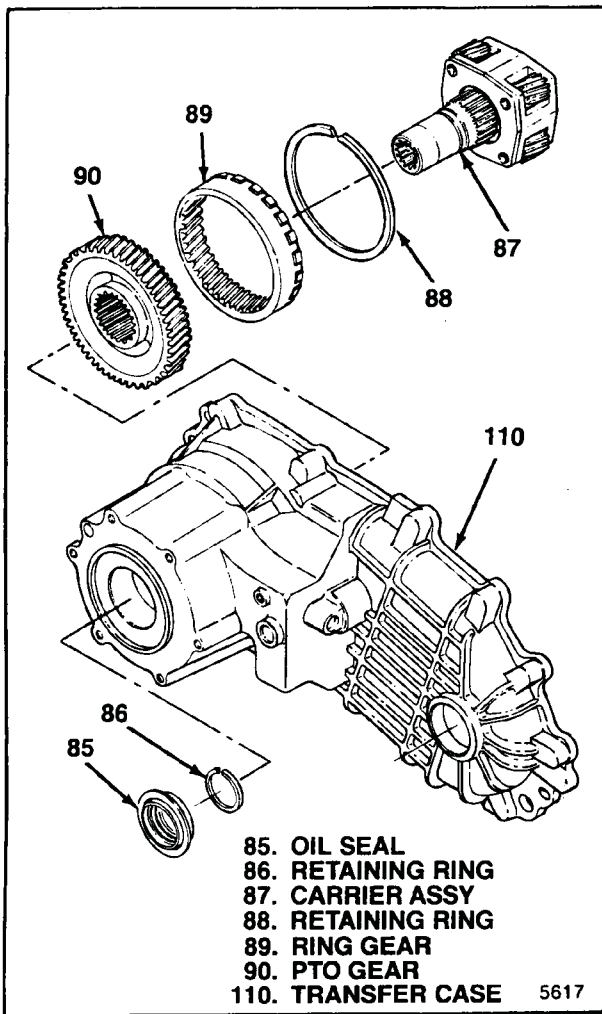

Figure 3-14. Carrier Assembly and Ring Gear

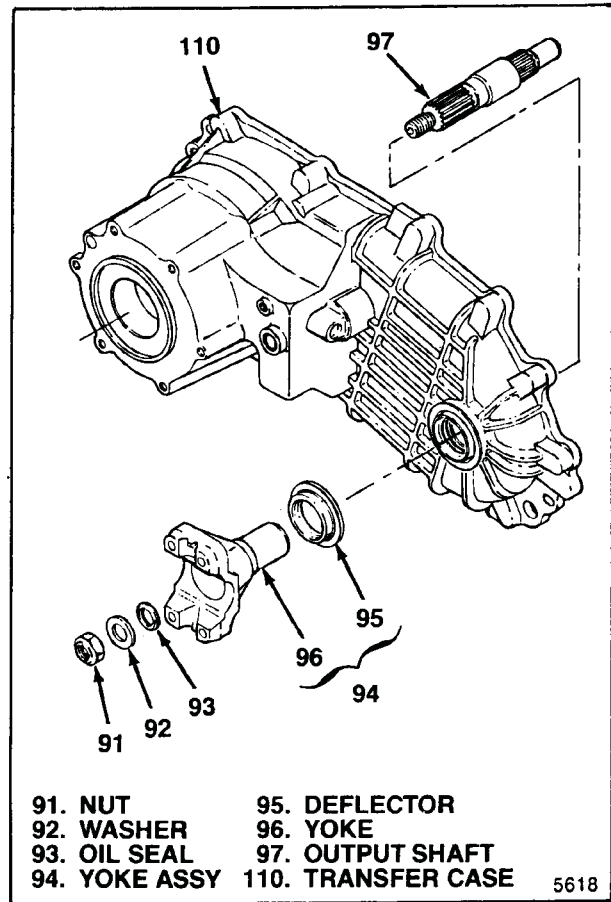

Figure 3-15. Front Output Shaft Group

f. From mechanical shift units, pull oil seal (108).
 g. Remove two dowel pins (109) from transfer case (110) only if they are loose or damaged.

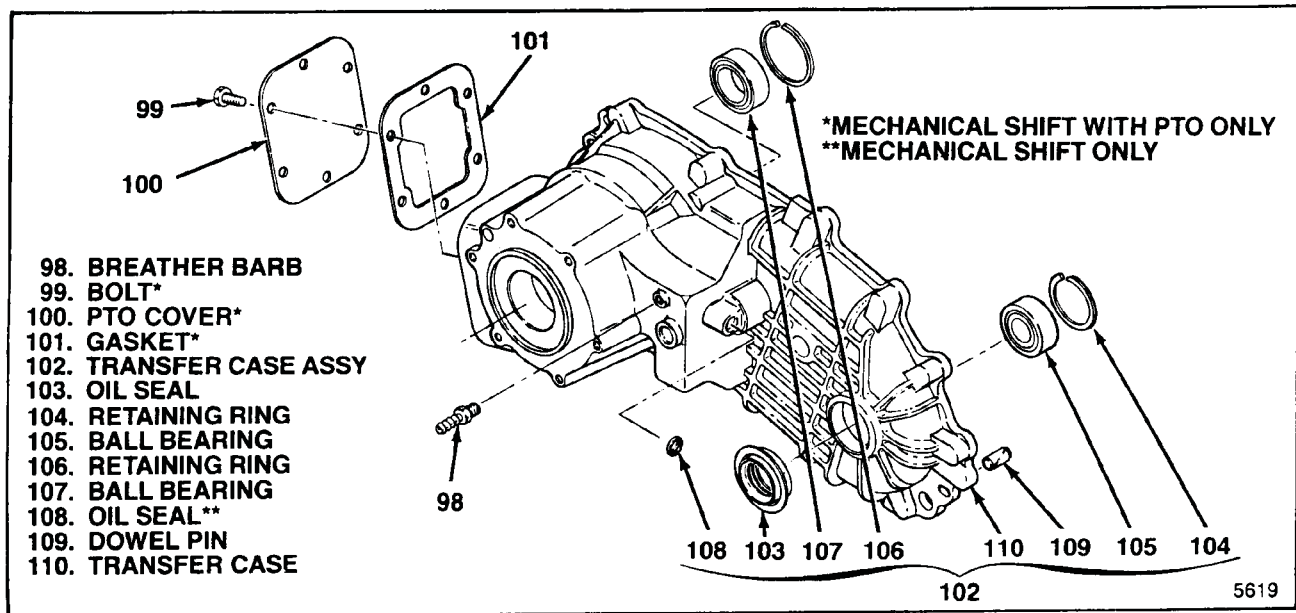

Figure 3-16. Transfer Case Assembly

Assembly

5-1. GENERAL INFORMATION

5-2. During assembly, refer to the illustrations specified in the text. In addition, an exploded view of the complete assembly can be viewed on the applicable illustration in Section P, Parts. The exploded view illustrations are listed at the beginning of Section P. Note the following during assembly:

- a. When a torque value is specified, use a torque wrench to tighten the threaded part. Torque values are specified in the text and also in Table 5-1.
- b. Liberally coat small parts with petrolatum to help hold them in place during assembly.
- c. Press in oil seals and bearings using universal drift T-13-56-001. Do not use a hammer to drive in oil seals and bearings.

5-3. LUBRICATION DURING ASSEMBLY. Lubricate all internal parts, not coated with petrolatum, with approved transfer case lubricant (refer to paragraph 2-4) just prior to assembly. This will ease assembly and provide initial lubrication.

- a. O-rings or shaft seals may be damaged if not lubricated prior to assembly.
- b. Make sure bearings and bushings are thoroughly lubricated before assembly. Running bearings or bushings dry, even for a brief period, will cause damage.
- c. Lubricate sealing lips of oil seals and mating metal parts prior to assembly together.

**Table 5-1. Torque Values
TORQUES FOR SPECIFIC PARTS**

PART (INDEX NO.)	TORQUE IN LB-FT	TORQUE IN Nm
Nut (1)	100-150	136-203
Nut (91)	150-180	203-244
4WD Switch (74)	25-35	34-47
Plug (7)	7-17	9-23
Bolt (8 and 27)	18-28	24-38
Bolt (15 & 17)	6-8	8-11
Bolt (16)	6-8	8-11
Bolt (99)	15-25	20-34
Nut (33)	6-8	8-11
Setscrew (75)	5.0-7.0	7.0-9.5
Breather Barb (98)	6-10	8-14

GENERAL TORQUES

THREAD SIZE	TORQUE IN LB-FT	TORQUE IN Nm
5/16-18 UNC	15.0-25.0	20.3-33.9
3/8-16 UNC	25.0-40.0	33.9-54.5
3/8-24 UNF	25.0-40.0	33.9-54.5
7/16-14 UNC	35.0-55.0	47.5-74.6
1/2-13 UNC	45.0-70.0	61.0-94.9
1/2-30 UNF	45.0-70.0	61.0-94.9
9/16-12 UNC	60.0-90.0	81.3-122.0
1/8-27 NPTF	7.0-15.0	9.5-20.3
1/4-18 NPTF	10.0-20.0	13.6-27.1
3/8-18 NPTF	15.0-25.0	20.3-33.9
1/2-14 NPTF	20.0-30.0	27.1-40.7
3/4-14 NPTF	25.0-40.0	3.9-54.5

5-4. ASSEMBLY OF TRANSFER CASE

5-5. ASSEMBLY OF CASE ASSEMBLY. Assemble parts which were removed from transfer case as follows (see figure 5-1):

a. If removed, press two new dowel pins (109) into transfer case to dimension shown in figure 5-2.

b. For mechanical shift units only, press in new oil seal (108) to dimension shown in figure 5-2.

c. Press in ball bearing (107) to bottom in transfer case (110) and install retaining ring (106).

d. Press in ball bearing (105) to bottom in transfer case (110) and install retaining ring (104).

e. Position new oil seal (103) as shown in figure 5-2 and press in to seat seal flange against transfer case (110).

f. For PTO units only, install gasket (101), PTO cover (100) and four bolts (99). Torque bolts to 15-25 lb-ft 20.3-34.0 Nm.

g. Install breather barb (98) and torque to 6-10 lb-ft (8-14 Nm).

5-6. ASSEMBLY OF FRONT OUTPUT SHAFT GROUP. To assembly as completed thus far (98 through 110), assemble the following (see figure 5-3):

a. If removed, press deflector (95) onto yoke (96).

b. Position output shaft (97) in transfer case (110) and install yoke assembly (94), oil seal (93), washer (92) and nut (91) on output shaft. Hold yoke with torque bar T-13-56-002 and torque nut to 150-180 lb-ft (203-244 Nm).

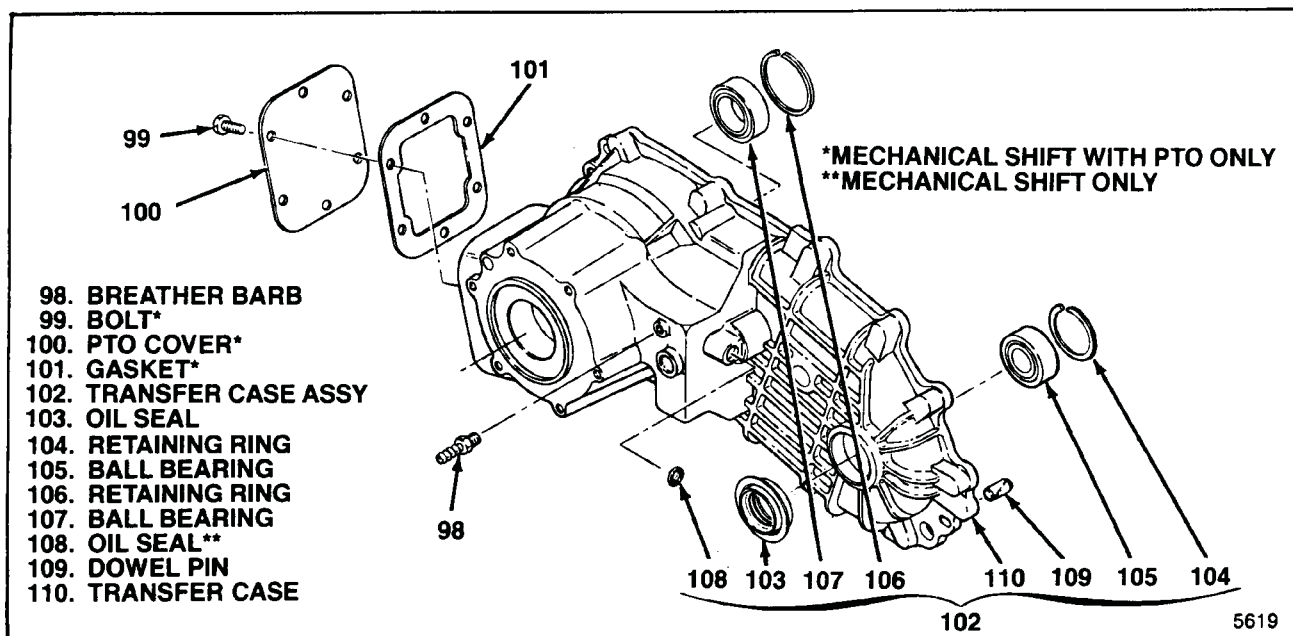

Figure 5-1. Transfer Case Assembly

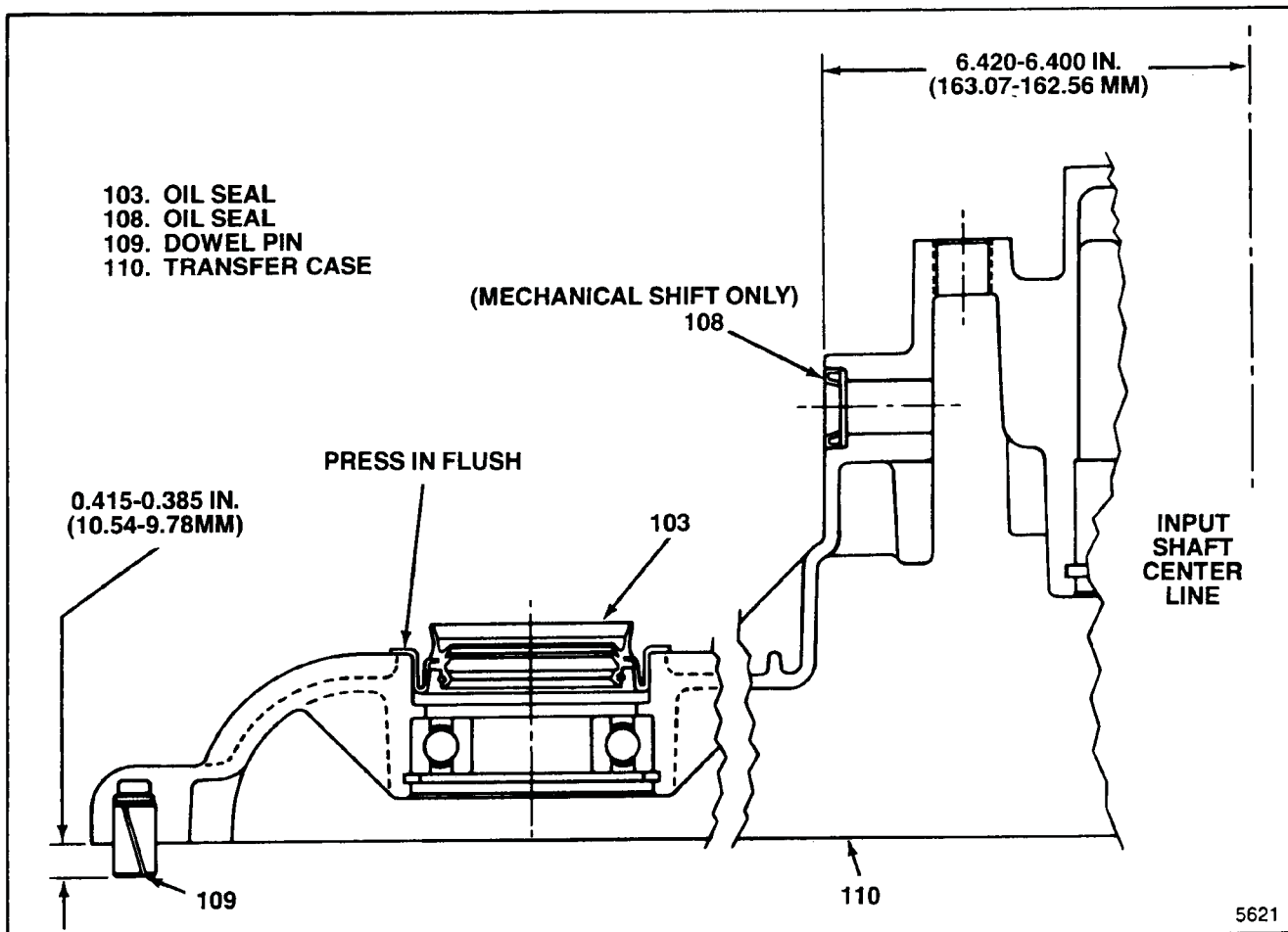

Figure 5-2. Installing Parts in Transfer Case

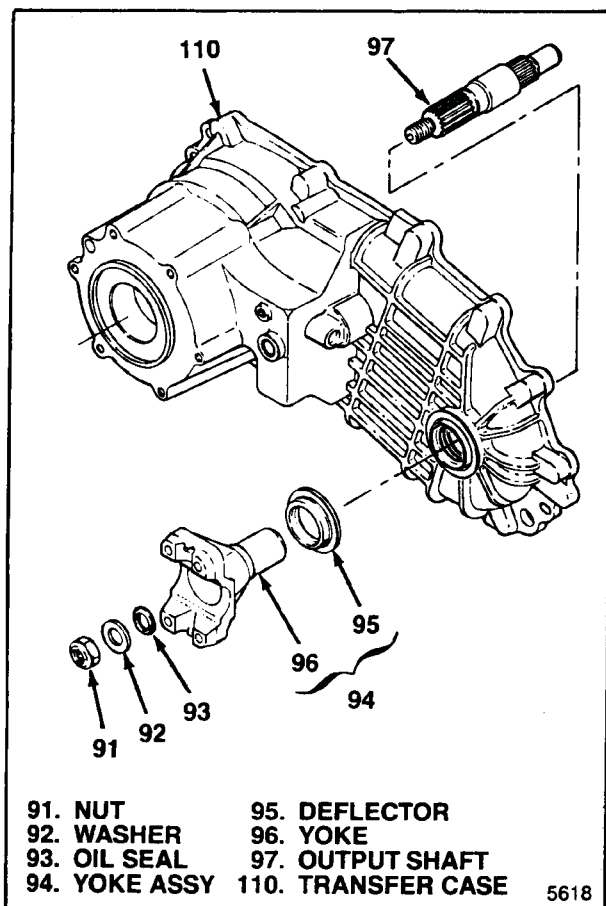

Figure 5-3. Front Output Shaft Group

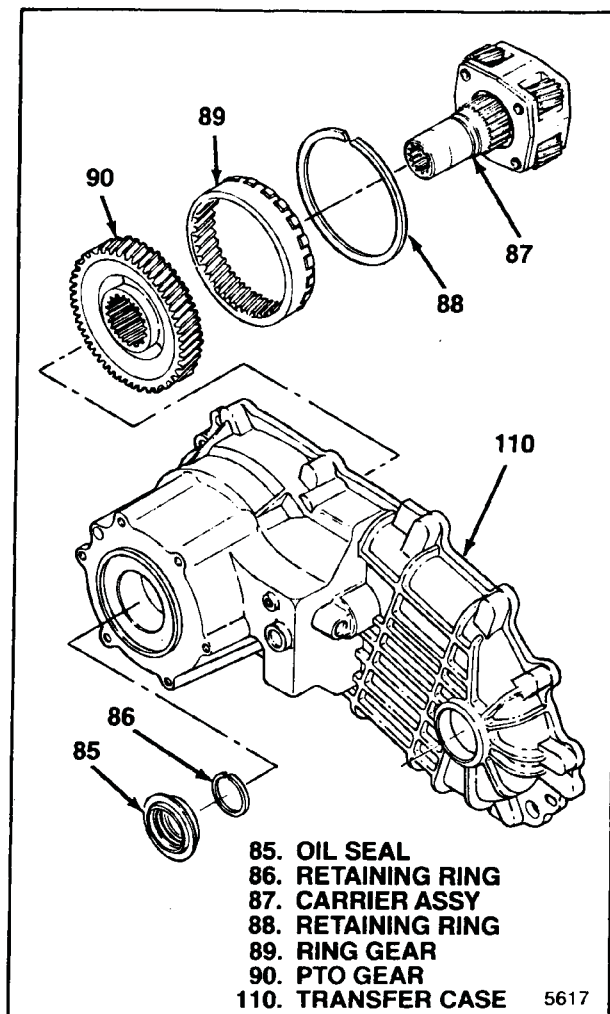

Figure 5-4. Carrier Assembly and Ring Gear

5-7. INSTALLATION OF RING GEAR AND CARRIER ASSEMBLY. To assembly as completed thus far (91 through 110), assemble parts as follows (see figure 5-4):

a. Install ring gear (89) in transfer case (110), lug end of gear last. Engage gear lugs with case notches and install retaining ring (88).

b. For units with PTO, align splines and install PTO gear (90) on input shaft of carrier assembly (87). Position gear with respect to carrier assembly as shown in figure 5-5.

c. Position carrier assembly (87), with installed PTO gear (90) if used, in transfer case (110) and install retaining ring (86) in groove in input shaft of carrier assembly.

d. Position oil seal (85) as shown in figure 5-5 and press into transfer case (110) until seal flange seats on case.

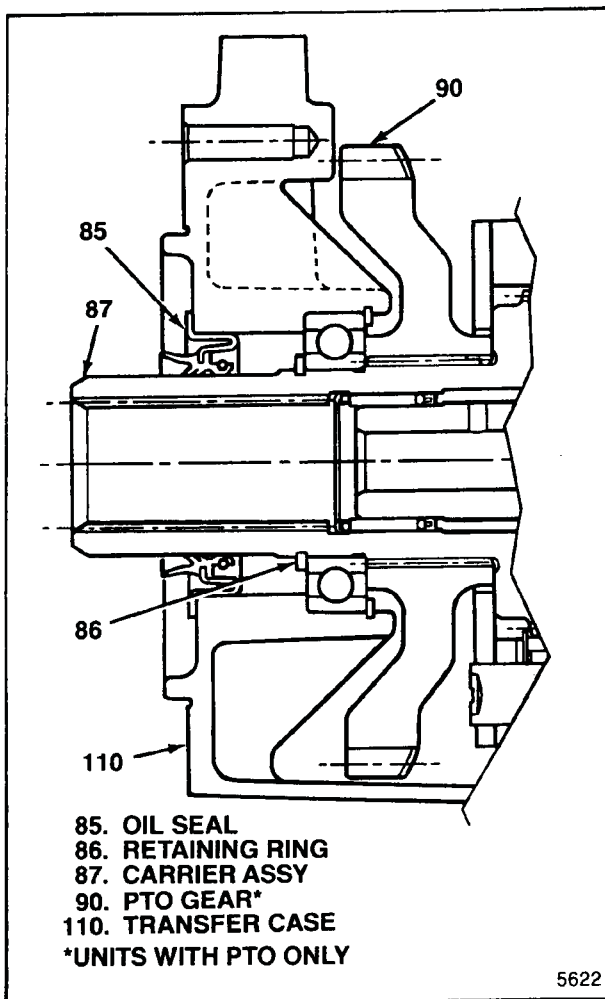

Figure 5-5. Oil Seal and PTO Gear Position

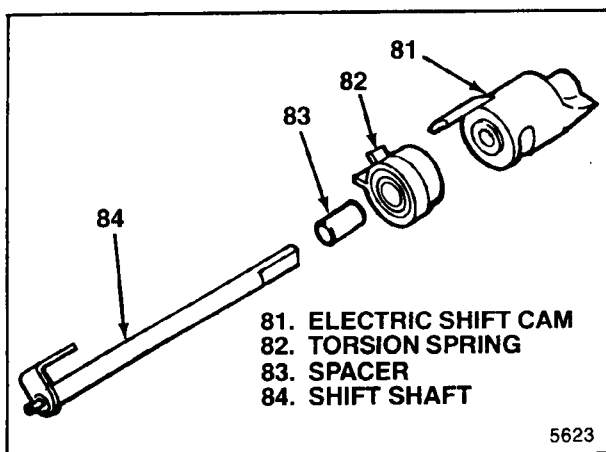

Figure 5-6. Electric Shift Cam Parts

5-8. ASSEMBLY OF SHIFT CAM PARTS (ELECTRIC SHIFT TRANSFER CASE ONLY). On electric shift units, assemble the following (see figure 5-6):

- a. Insert spacer (83) in torsion spring (82) ID and install over free end of shift shaft (84).
- b. Slide torsion spring (82) and spacer (83) on shift shaft (84) up to drive tang and position first spring end to left (viewed from free end of shaft) of drive tang (see figure 5-7).
- c. Twist second spring (82) end to right of drive tang on shift shaft (84) (see figure 5-8).
- d. Push torsion spring (82) and spacer (83) together back as far as they will go (see figure 5-9).
- e. Slide electric shift cam (81) onto shift shaft (84), drive tang on cam first. Position drive tang on cam so that it will go under drive tang on shift shaft and between spring ends and slide cam as far as it will go.
- f. Defer installation of completed electric shift cam assembly (81 through 84) in transfer case assembly until after shift forks are installed (paragraph 5-13).

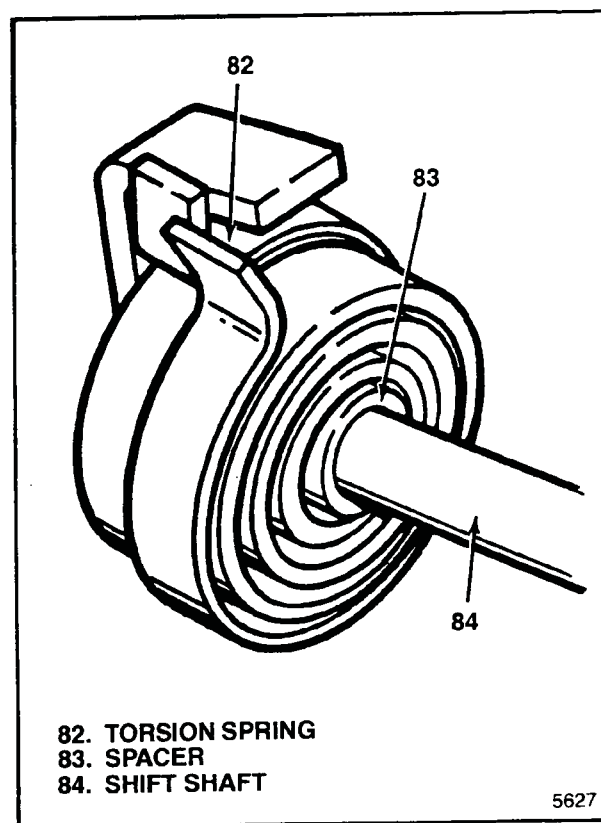

Figure 5-7. Installing First Spring End

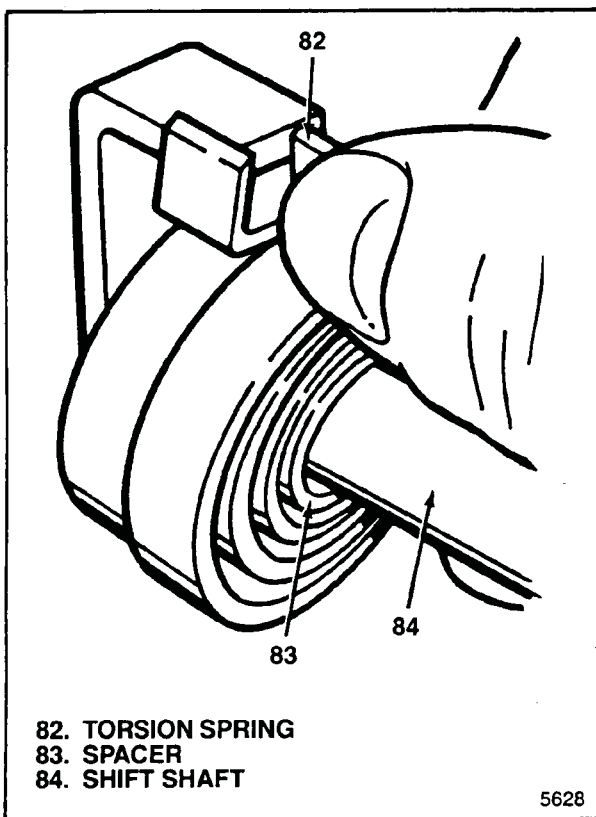

Figure 5-8. Installing Second Spring End

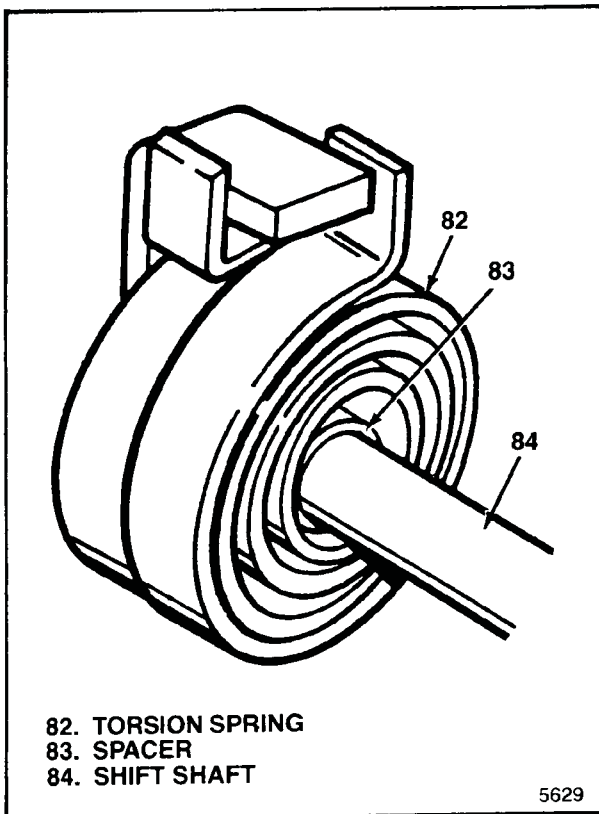

Figure 5-9. Completing Spring Assembly

5-9. ASSEMBLY OF SHIFT CAM PARTS (MECHANICAL SHIFT TRANSFER CASE ONLY). On mechanical shift units, install parts as follows (see figure 5-10):

- a. Lubricate shaft and install lever, shaft and pin assembly (77). Start splined end of shaft into transfer case (110) until end is flush with inside of case.
- b. Start setscrew (75) into shift cam (80). Insert shift cam into transfer case. Position both cam and lever shaft and pin assembly (77) as shown in figure 5-11, align cam and shaft splines and install lever, shaft and pin assembly fully into cam.
- c. Install klip ring (76) in groove near inside end of shaft on lever, shaft and pin assembly (77) to retain shift cam (80).
- d. Tighten setscrew (75) to 5-7 lb-ft (7.0-9.5 Nm) through hole in transfer case (110) for 4WD indicator switch (74).
- e. Install assist bushing (79) on end of assist spring (78) and install in groove in shift cam (80) closest to lever, shaft and pin assembly (77). Install other end of spring through case bracket notch and into hole in transfer case (110).
- f. Install 4WD indicator switch (74) and torque to 25-35 lb-ft (34-47 Nm)

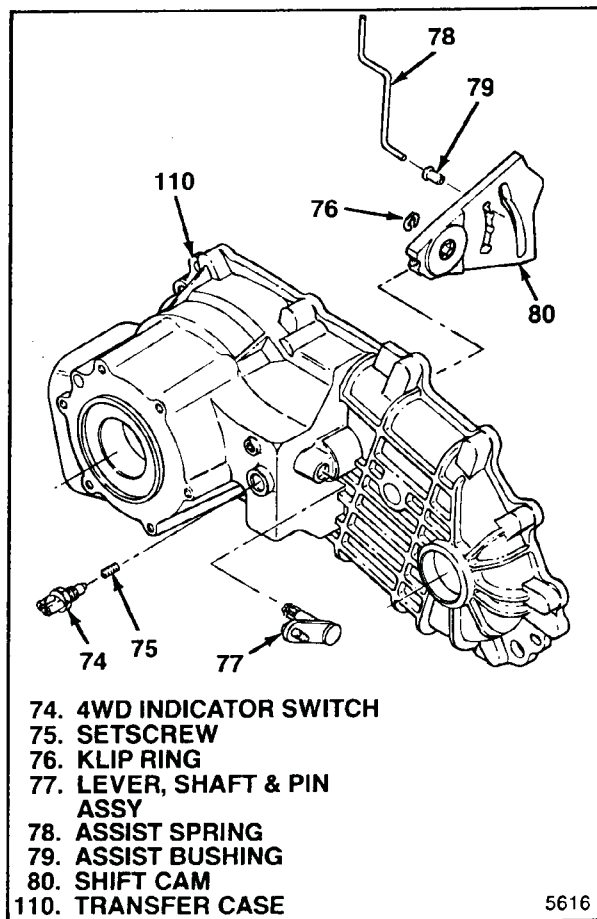

Figure 5-10. Mechanical Shift Cam Parts

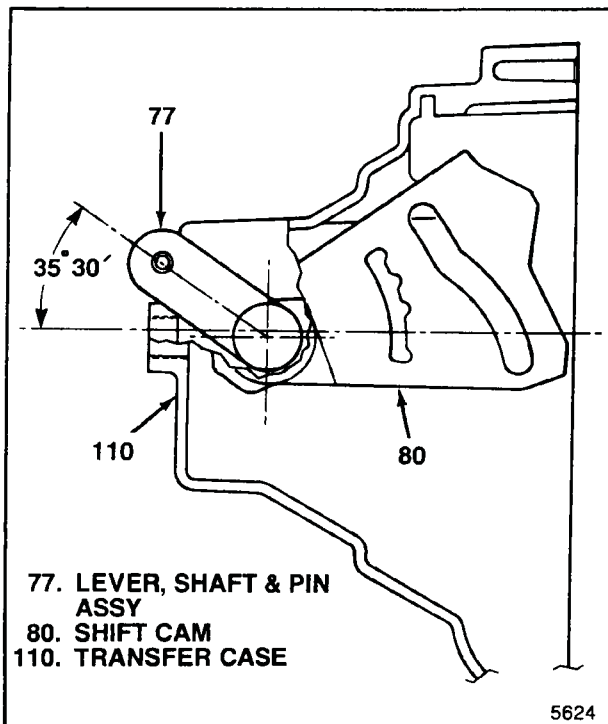

Figure 5-11. Cam and Lever Positions

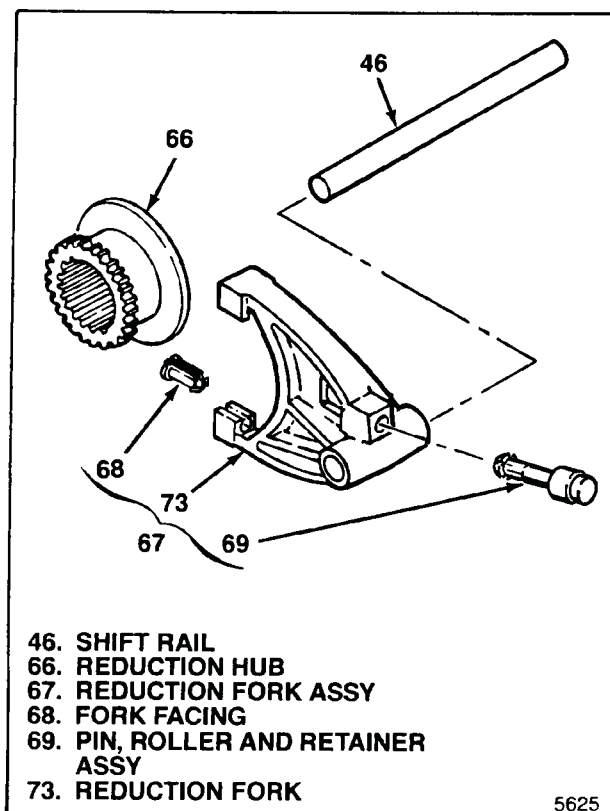

Figure 5-12. Reduction Shift Parts

5-10. ASSEMBLY OF REDUCTION SHIFT PARTS.

Assemble and install parts as follows (see figure 5-12):

a. If removed, install new pin, roller and retainer assembly (69). Press pin, roller and retainer assembly into bore in reduction fork (73) until retainer passes completely through and snaps in place. Make sure that roller turns freely.

b. Install two fork facings (68) on reduction fork (73).

c. Engage reduction shift fork assembly (67) with reduction hub (66) and position in transfer case, reduction hub in carrier assembly (87) previously installed. On mechanical shift units only, engage fork roller in cam slot in shift cam previously installed.

d. Install shift rail (46) through reduction fork assembly (67) and into blind hole in case to hold fork in place.

NOTE

Installation of output shaft (65) in case may be deferred and oil pump assembled to shaft (paragraph 5-11) on work bench. Assembled pump can be tested by immersing filter in transmission oil (Table 2-2) and rotating shaft in counterclockwise direction when viewed from output end. Assembled parts then can be installed in transfer case as a unit.

5-11. INSTALLING OIL PUMP. Be sure to thoroughly lubricate pump parts as they are assembled but keep oil out of tapped holes in pump front cover. To assembly as completed thus far (66 through 110) assemble parts as follows (see figure 5-13):

a. Install output shaft (65) in reduction hub (66) and carrier assembly (87) previously installed in transfer case.

b. Locate pump front cover (64). Front pump cover has tapped holes. Position front cover so that word TOP faces down and turned so that it will be at top of transfer case when installed in vehicle. Install front pump cover over output shaft (65) in this position.

CAUTION

In following step, pump pins (62) must be positioned properly or pump will not function.

c. Install two pump pins (62) with spring (63) between them in output shaft (65). Flat surface on both pins must point out and face up. Center pins and spring in output shaft.

d. Push hose coupling (59) onto barb on strainer (60) and install L shaped foot on filter in slot in transfer case. Hose coupling must point in direction of pump assembly.

e. Install pump housing (61) so that word REAR marked on it is up and hose barb points toward hose coupling (59) and strainer (60). Lower pump housing over upper output shaft, moving pump pins (62) inward and compressing spring (63) so that both pins are contained inside pump housing.

f. Slip hose clamp (58) over free end of hose coupling (59) and push onto hose barb on pump housing (61).

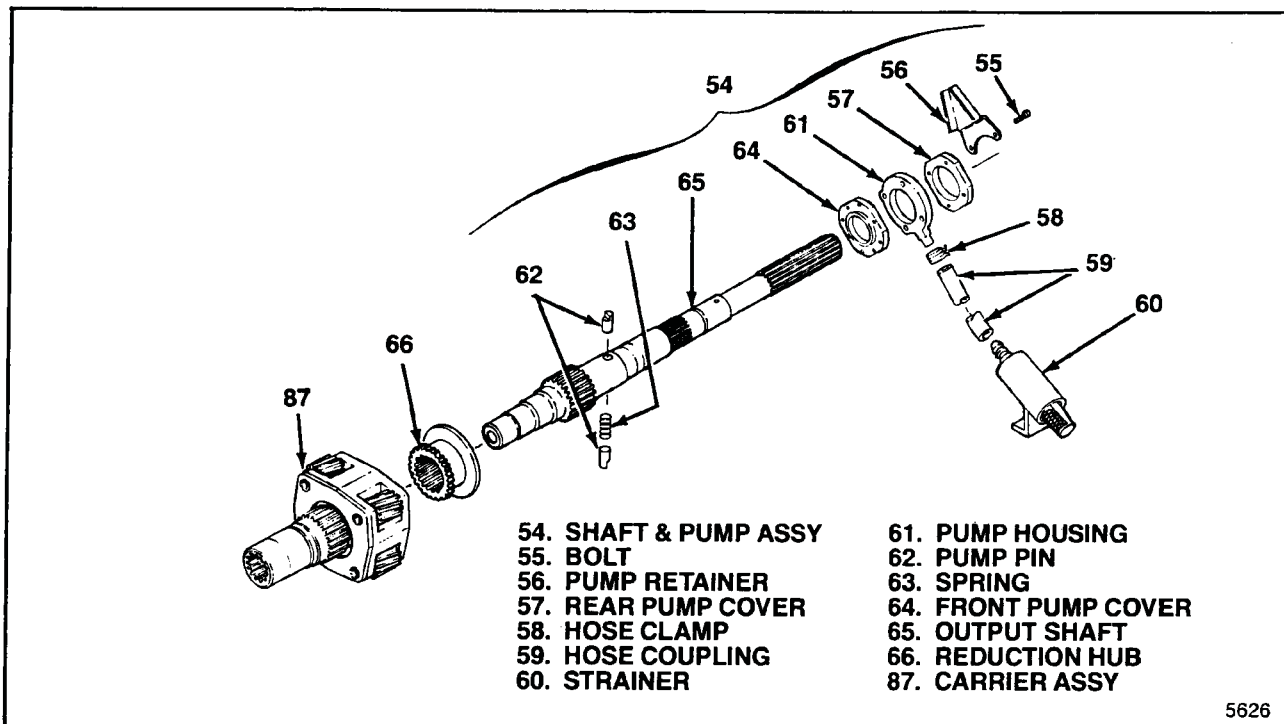

5626

Figure 5-13. Pump Parts

Secure hose clamp over hose coupling on hose barb
 g. Position pump rear cover (57) over assembly with words TOP REAR facing up and located to be at top of transfer case when installed. Position pump retainer (56) on cover so that tab on retainer is in notch in transfer case. Align pump holes and install four bolts (55). Torque bolts to 35-75 lb-in. (3.9-8.5 Nm) while turning output shaft (65) by hand to insure that pump pins (62) move freely.

5-12. INSTALLATION OF CHAIN DRIVE. To assemble as completed thus far (54 through 110) assemble parts as follows (see figure 5-14):

a. On work bench, next to transfer case assembly, position driven sprocket (52) (with internal spline) at front output shaft (97) end of case and drive sprocket (51) (with smooth bore) at rear output shaft (65) end.

b. Assemble drive chain (53) around sprockets (51 and 52).

c. Grasp each sprocket (51 and 52), hold drive chain (53) tight and parallel with transfer case, and install chain drive assembly (51 through 53) over output shafts (97 and 65). It may be necessary to rotate driven sprocket (52) slightly to engage splines on front output shaft (97).

d. Install washer (50) on front output shaft (97). Install retaining ring (49) in shaft groove over washer.

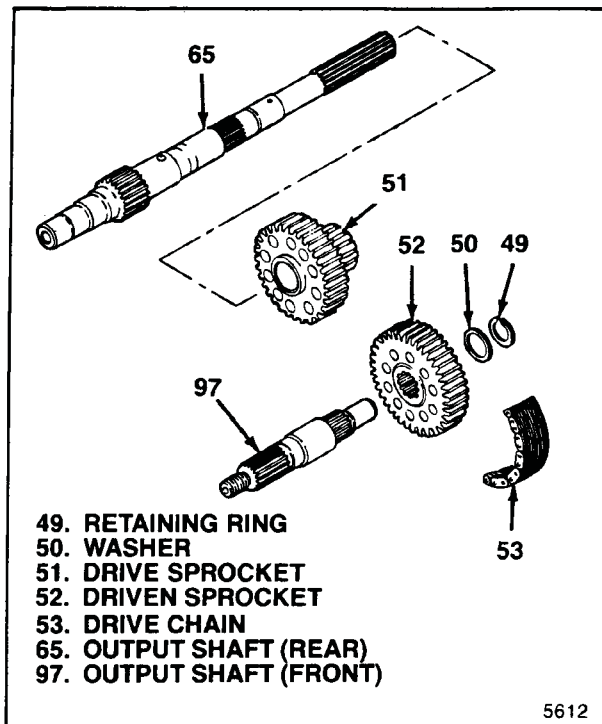

5612

Figure 5-14. Chain Drive

5-13. INSTALLING LOCKUP SHIFT PARTS. To assembly as completed thus far (49 through 110) install parts as follows (see figure 5-15 for electric shift; 5-16 for mechanical shift):

a. Install two fork facings (48) on lockup fork assembly (47).

b. Assemble return spring (44) and lockup hub (43) in lockup collar (45) and retain with snap ring (42), completing 2W-4W lockup assembly (41).

c. Engage lockup fork assembly (47) in groove in 2W-4W lockup assembly (41) and slide this group down over output shaft (65) and shift rail (46) previously installed.

d. Install shift collar hub (40), engaging splines on output shaft (65) and in 2W-4W lockup assembly (41).

e. On electric shift units only, install electric shift cam group (81 through 84) previously assembled (paragraph 5-8) as follows (see figure 5-17):

1. Position electric shift cam group as shown in figure 5-17, rotated so that end of torsion spring (82) will contact side of reduction shift fork assembly (67) that faces up, toward top of case.

2. Holding shift rail (46) down, raise up fork assemblies (67 and 47) slightly. Rotate electric shift cam group into position so that roller on reduction fork assembly (67) is in groove in shift cam (81) and roller on lockup fork assembly (47) is on cam end. Then lower this group of parts into the transfer case engaging shift shaft (84) pin in transfer case.

f. On electric shift units only, install clutch housing (39) over end of output shaft (65).

g. On all units, install snap ring (38) in groove in output shaft (65).

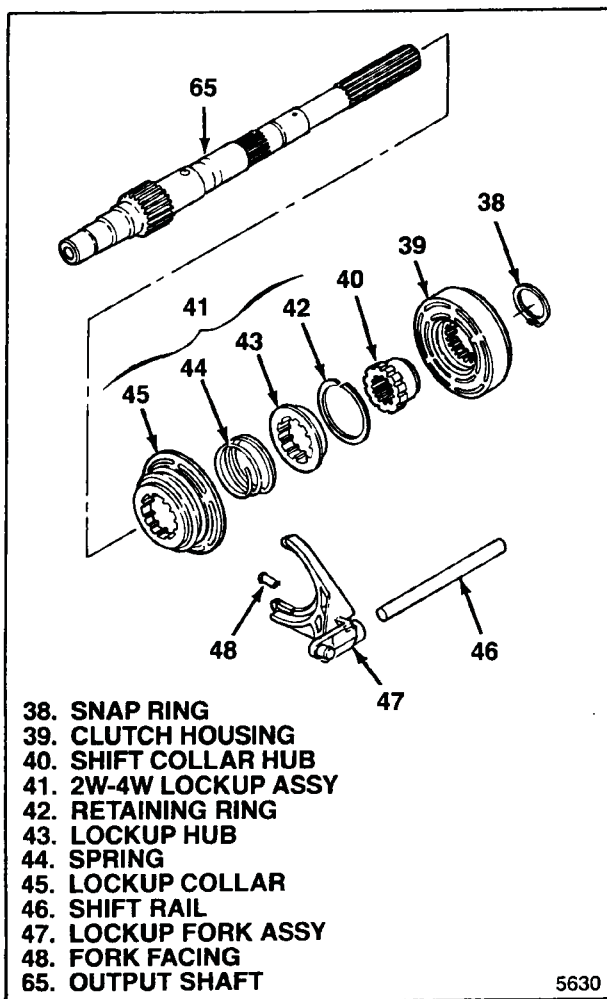

Figure 5-15. Lockup Shift Parts (Electric Shift)

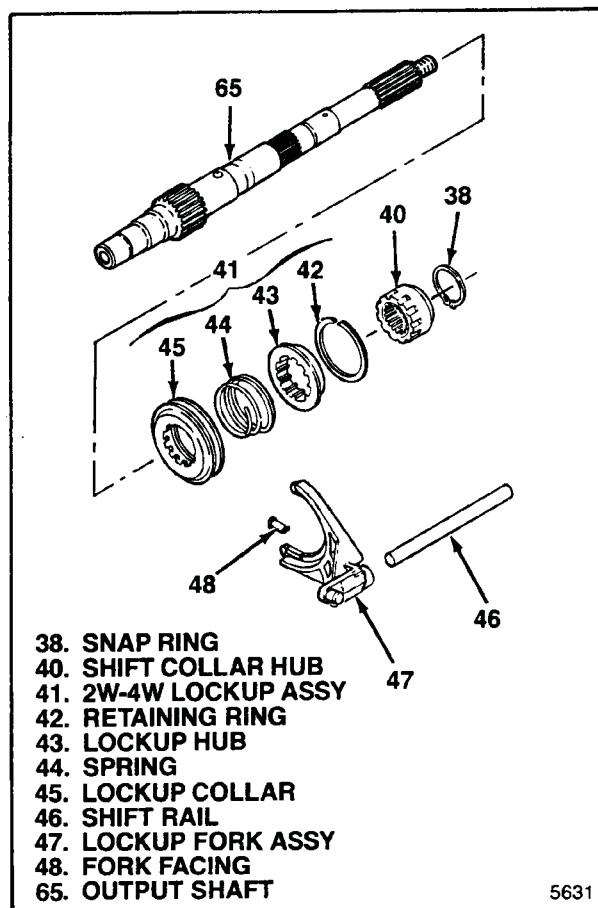

Figure 5-16. Lockup Shift Parts (Mechanical Shift)

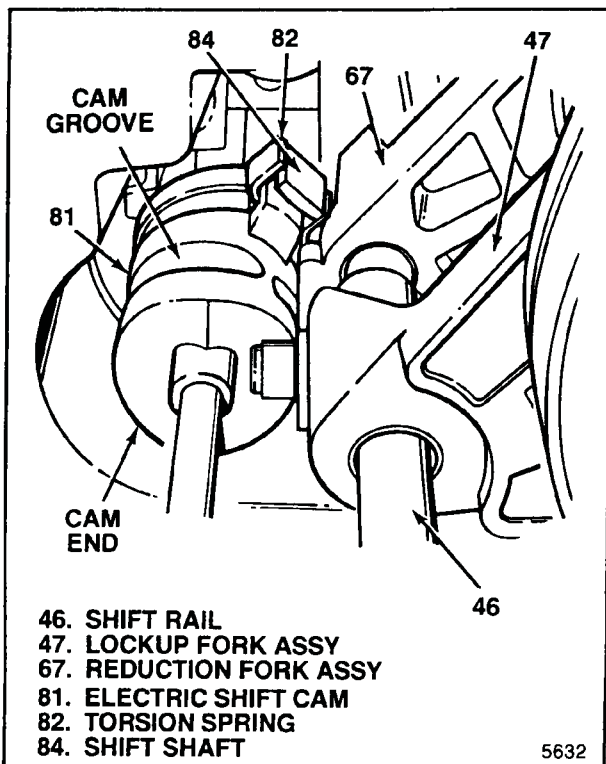

Figure 5-17. Electric Shift Cam Installation

5-14. **COVER ASSEMBLY.** Assemble parts into cover as follows (see figure 5-18 for electric shift; figure 5-19 for mechanical shift):

a. On electric shift units only, verify that four o-rings (one on wire and one each on three studs) are in place on clutch coil assembly (34). Install clutch coil assembly in inside of case cover, with electrical wire and studs extending through cover. Use care not to kink or trap electrical wire under clutch coil assembly. Attach with three nuts (33) and torque to 6-8 lb-ft (8.1-11.0 Nm).

b. On electric shift units only, press sleeve bearing (32) and oil seal (31) into cover to dimension shown in figure 5-20) using suitable drift.

c. Position cover (35) on bed of suitable press so that open face of cover is up and parallel with press bed.

d. Position end of needle bearing (30) with identification marking up and press into cover (35) to dimension shown in figure 5-20.

e. Press in ball bearing (29) to bottom in cover (35).

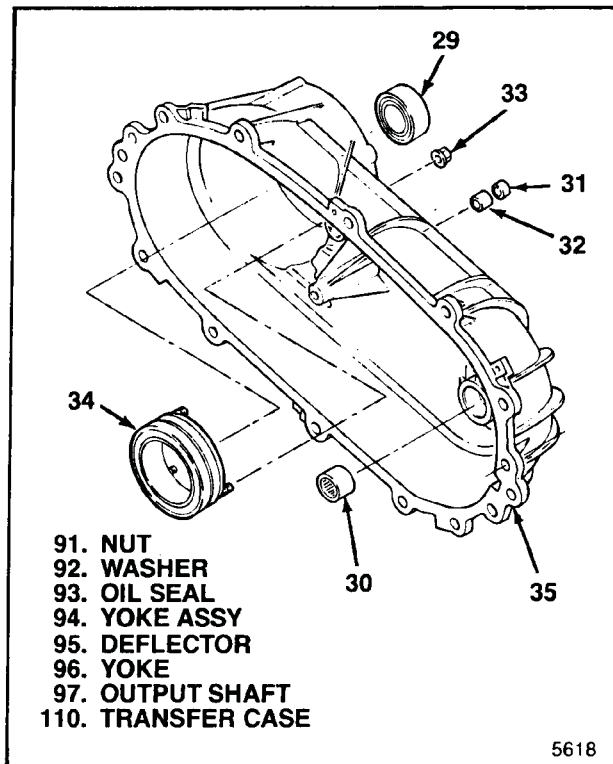

Figure 5-18. Cover Assembly (Electric Shift)

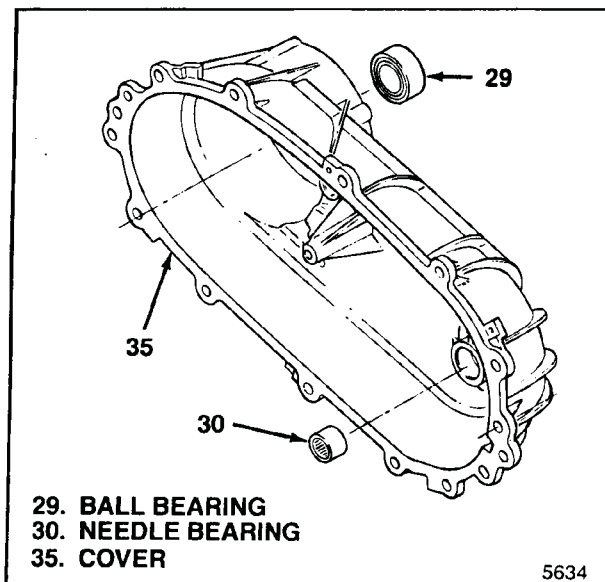

Figure 5-19. Cover Assembly (Mechanical Shift)

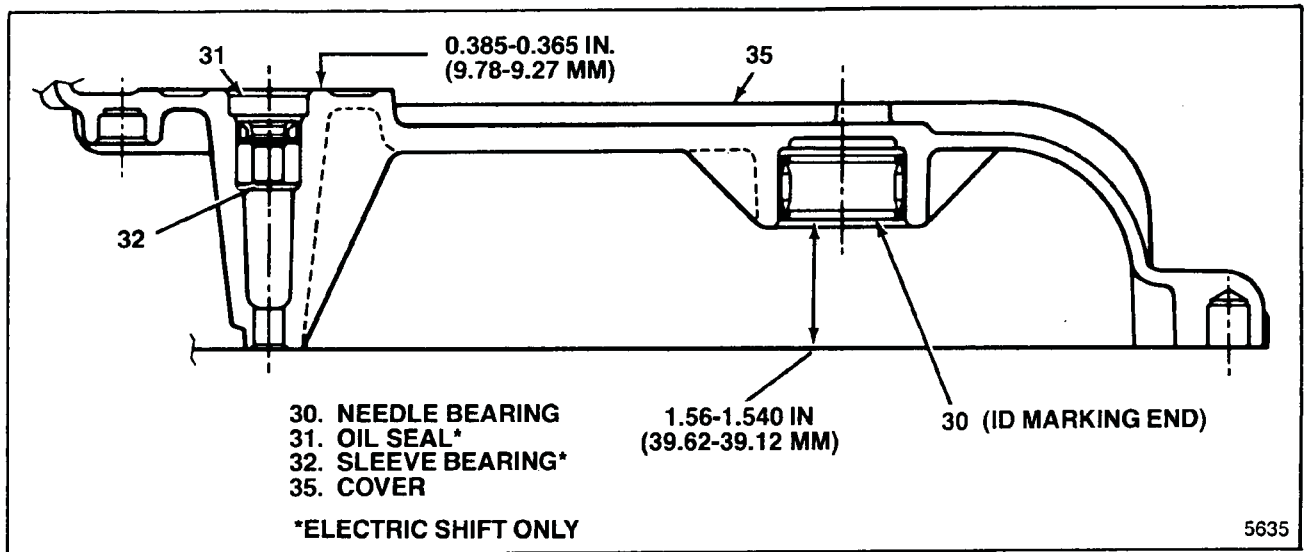

Figure 5-20. Cover Assembly Dimensions

5-15. INSTALLING COVER ASSEMBLY. Install cover assembly as completed in paragraph 5-14 on transfer case as follows (see figure 5-21):

a. Install return spring (37) over shift rail (46) in transfer case to rest on shift fork.

b. Install magnet (36) in slot in transfer case (110).

c. Apply continuous 1/16 in. (1.6 mm) bead of sealant (Neutral Cure RTV, Loctite 598) all around transfer case (110) mounting face for cover assembly (28). Center sealant bead between edges of face. Circle bolt holes.

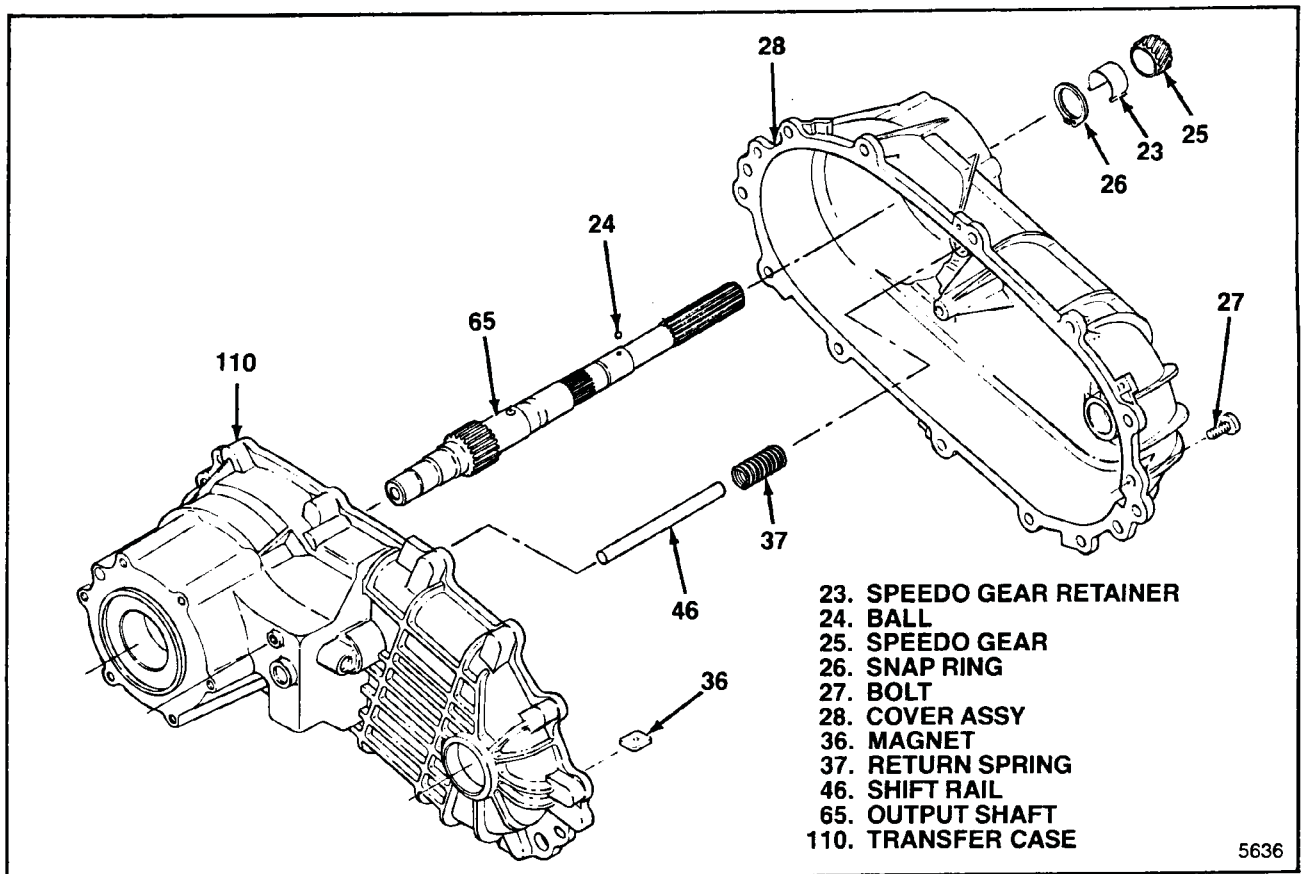

Figure 5-21. Cover Installation

CAUTION

In the following step do not use excessive force in an attempt to seat cover on transfer case. When all of the alignment conditions specified are met, the cover will seat without using undue force. If not, remove cover assembly and check alignment conditions.

d. Install cover assembly (28) on transfer case (110). All of the following alignment conditions must be met for the cover assembly to seat on transfer case properly (see figure 5-22):

1. Cover holes with transfer case dowel pins (109).
2. Cover bearings with output shafts (65 and 97).
3. Blind hole in cover with rail shaft (46) (make sure spring is not cocked).
4. On electric shift units, cover bore with shift shaft (84).
- e. Install twelve bolts (27) and torque to 18-28 lb-ft (24-38 Nm).
- f. Install snap ring (26) in groove in output shaft (65).
- g. Install speedo gear (25) over spline of output shaft (65) with open end of notch for ball (24) facing out and aligned with ball detent in output shaft. Push gear in as far as it will go, install ball (24) in detent in output shaft (65) and pull gear back out as far as it will go. Snap speedo gear retainer onto output shaft to retain speedo gear.

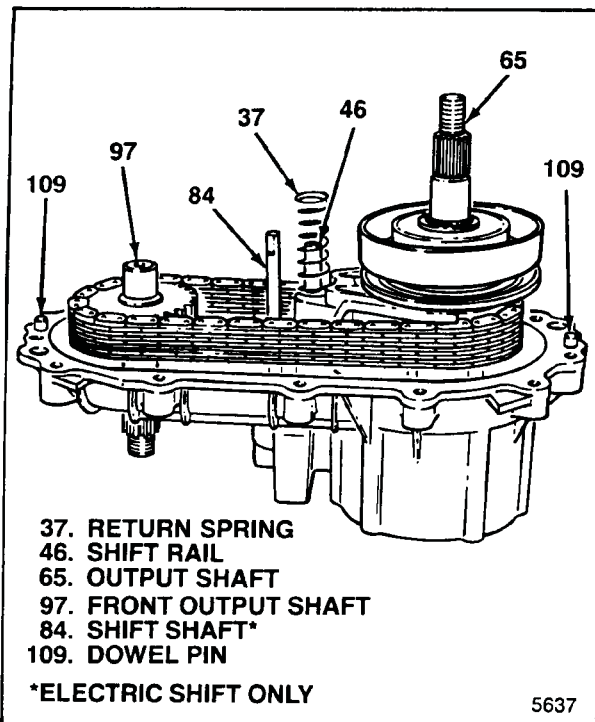

Figure 5-22. Parts To Be Aligned With Cover

5-16. INSTALLING EXTERNAL ELECTRIC SHIFT COMPONENTS (ELECTRIC SHIFT TRANSFER CASE ONLY) (See figure 5-23). On electric shift units, install components as follows:

b. Position motor assembly (22) so that triangular slot in motor will align with shift shaft (84) (see figure 5-24). Move motor in to engage shift shaft and contact cover (35). Then rotate motor in clockwise direction until motor is in correct position (see figure 5-25) and mounting holes are aligned. Install bolts (16) and torque to 6-8 lb-ft (8-11 Nm).

c. Install bolt (15) at bracket end of motor assembly (22) and torque to 6-8 lb-ft (8-11 Nm).

d. Fit o-ring (21) on speed sensor (20) and install in cover.

e. Attach bracket (18) with bolts (17) and torque to 6-8 lb-ft (8-11 Nm).

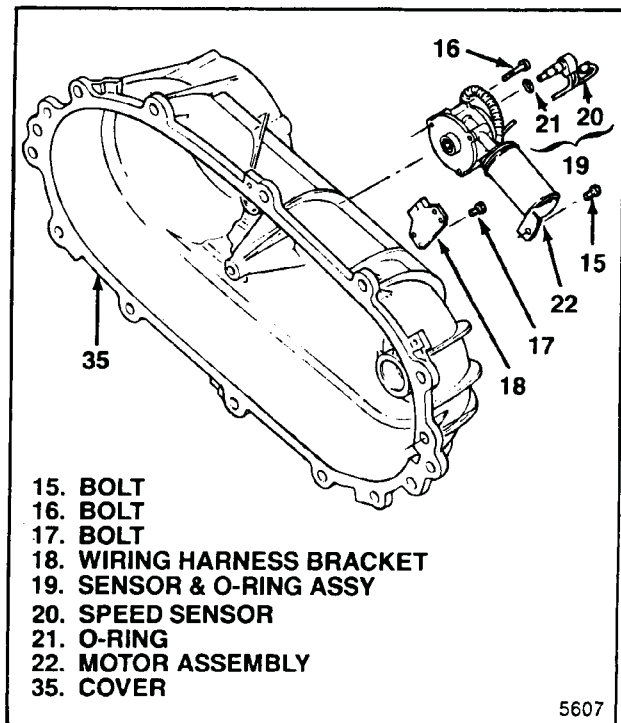

Figure 5-23. External Electric Shift Components

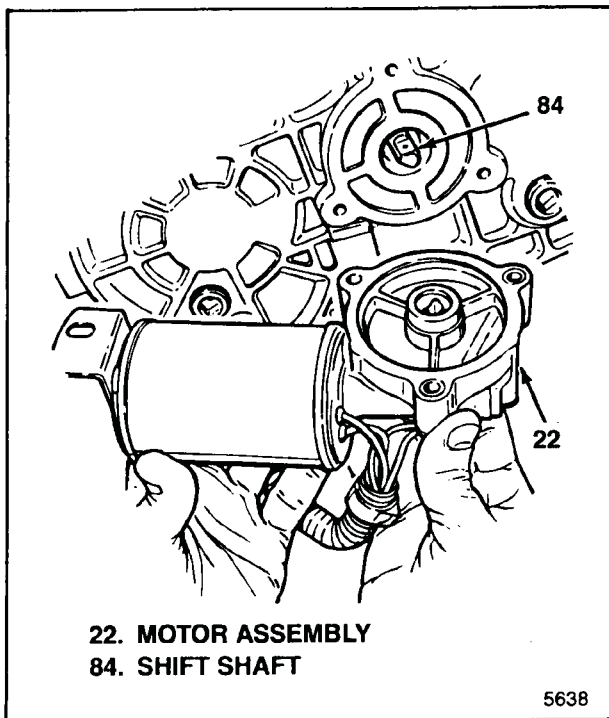

Figure 5-24. Motor Assembly Alignment

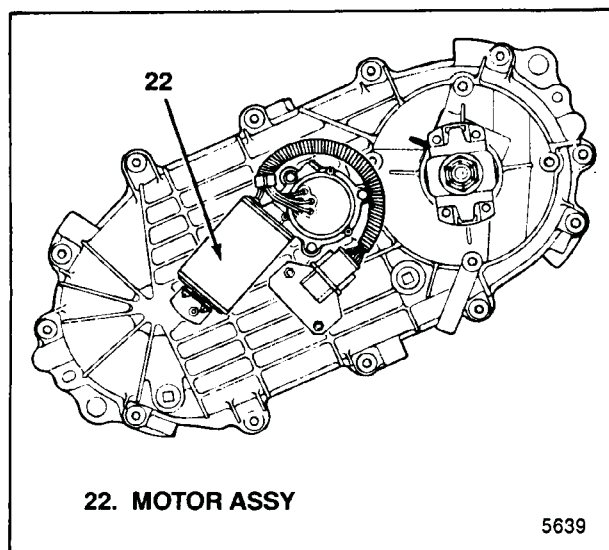

Figure 5-25. Motor Location

5-17. ASSEMBLY AND INSTALLATION OF BEARING CAP OR EXTENSION GROUP. Proceed as follows (see figure 5-26 for rear yoke or flange; figure 5-27 for rear spline):

- a. Attach speedo plate (12) to bearing cap (14) with stud bolt (13).
- b. For rear spline units only, press new bushing (11) into extension (14) using suitable drift.
- c. Press new oil seal (10) into bearing cap or extension (14).
- d. Apply continuous 1/16 in. (1.6 mm) bead of sealant (Neutral Cure RTV, Loctite 598) all around cover (35) mounting face for bearing cap or extension assembly (9). Center sealant bead between edges of face. Circle bolt holes.
- e. Install bearing cap or extension assembly (9) on cover (35) and attach with four bolts (8). Install identification tag (111) under head of one bolt at location shown in figure 5-28. Torque bolts to 18-28 lb-ft (24-38 Nm).
- f. Install fill and level plugs (two plugs) and torque to 7-17 lb-ft (9-23 Nm).

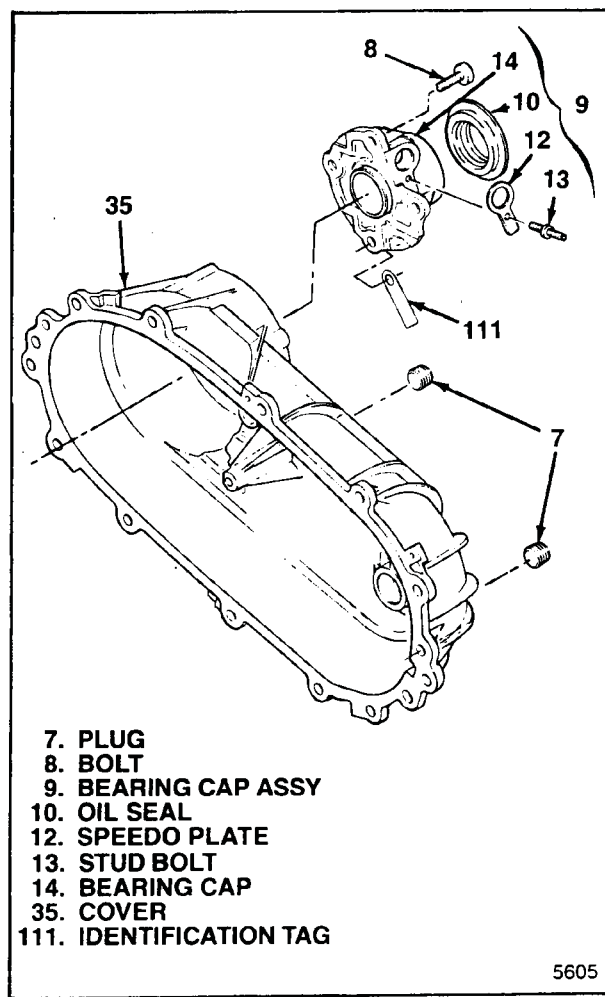
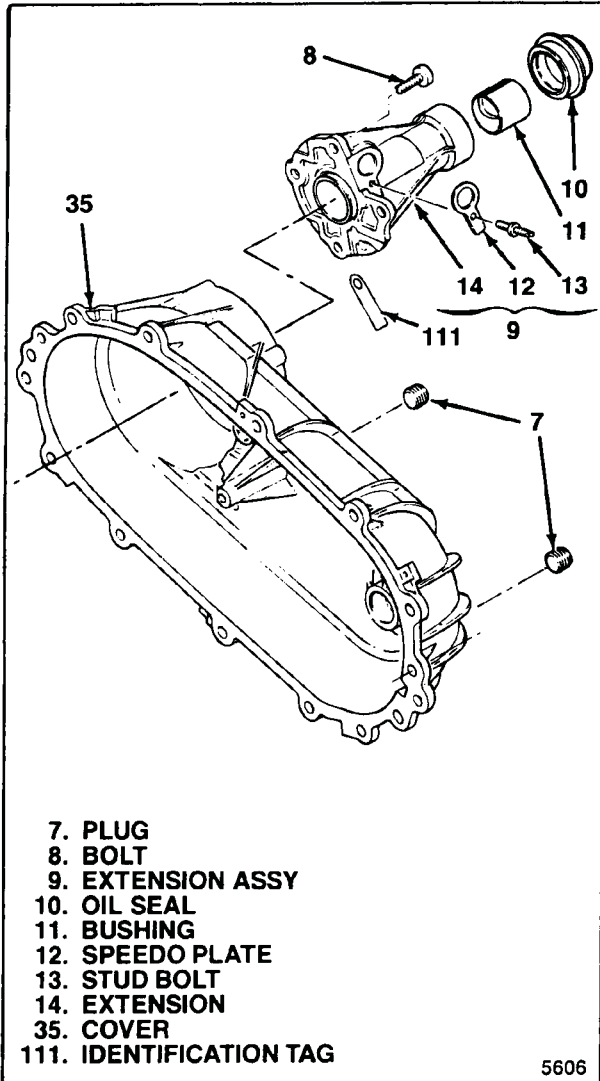

Figure 5-26. Bearing Cap Group (Rear Yoke or Flange)



- 7. PLUG
- 8. BOLT
- 9. BEARING CAP ASSY
- 10. OIL SEAL
- 11. BUSHING
- 12. SPEEDO PLATE
- 13. STUD BOLT
- 14. EXTENSION
- 35. COVER
- 111. IDENTIFICATION TAG

5606

Figure 5-27. Bearing Cap Group (Rear Spline)

5-18. INSTALLING REAR YOKE OR FLANGE GROUP. To assembly as completed thus far (7 through 111), install parts as follows (see figure 5-29):

- a. If removed, press deflector (5) onto yoke or flange (6).
- b. Install yoke or flange assembly (4), oil seal (3), washer (2) and nut (1).
- c. Hold yoke or flange with torque bar T-13-56-002 and torque nut (1) to 100-150 lb-ft (136-203 Nm).

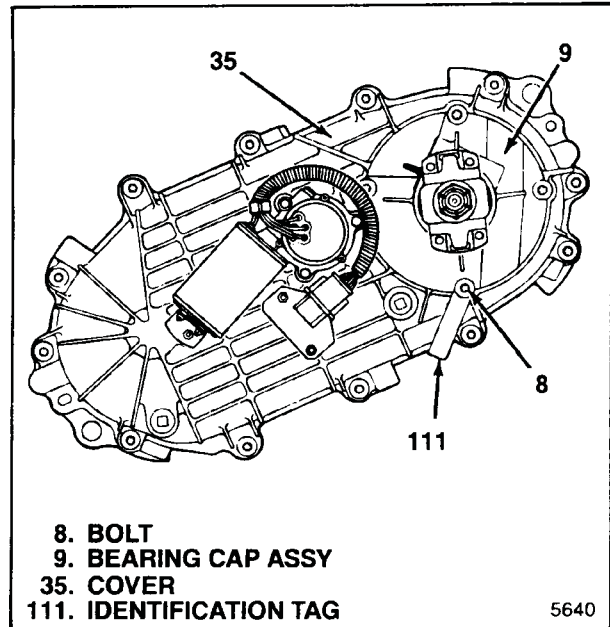

- 8. BOLT
- 9. BEARING CAP ASSY
- 35. COVER
- 111. IDENTIFICATION TAG

5640

Figure 5-28. Identification Tag Location

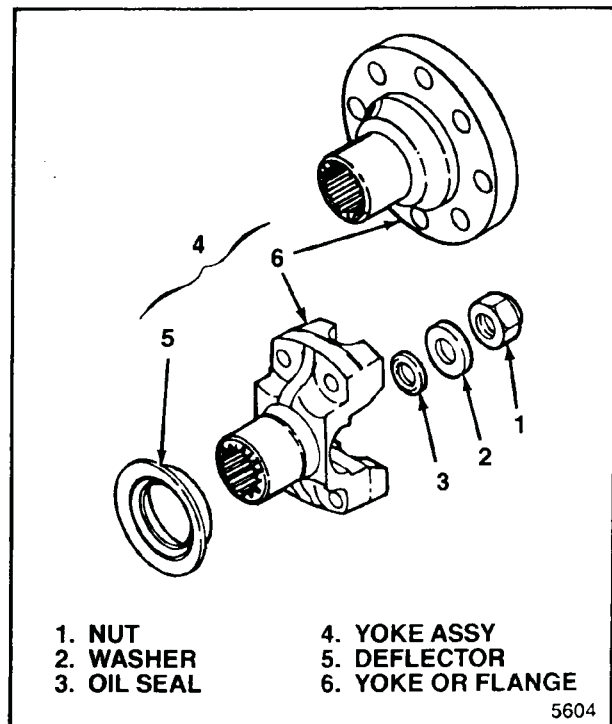

- 1. NUT
- 2. WASHER
- 3. OIL SEAL
- 4. YOKE ASSY
- 5. DEFLECTOR
- 6. YOKE OR FLANGE

5604

Figure 5-29. Rear Yoke Group

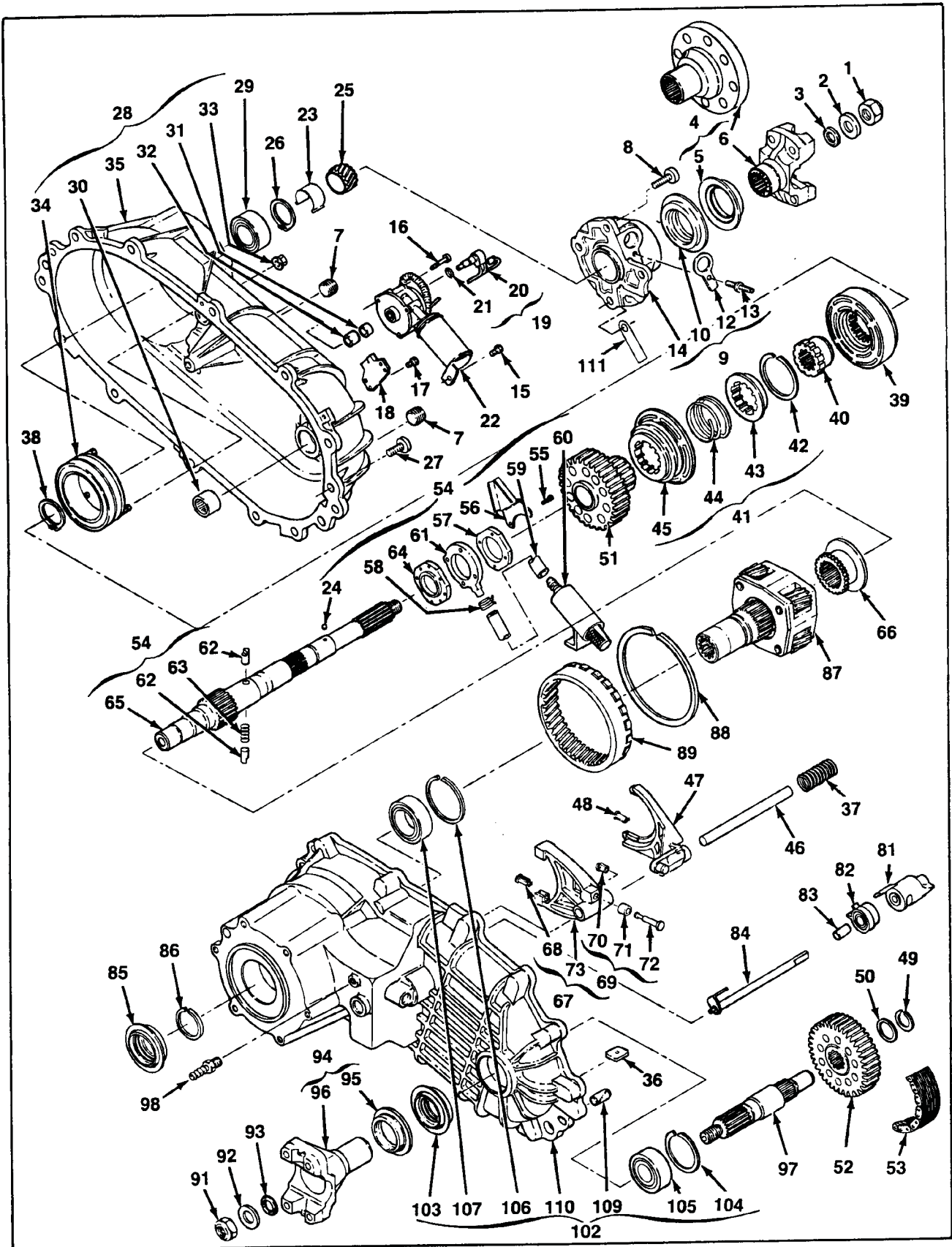

Figure P-1. Transfer Case Assembly, Electric Shift

Parts

Contents

Application	Description	Figure No.
Electric Shift	Transfer Case Assembly	P-1
Mechanical Shift	Transfer Case Assembly	P-2

P-1. INTRODUCTION.

P-2. This section lists, describes and illustrates replacement parts for the Borg-Warner Automotive 13-56 Transfer Case. Each exploded view illustration, listed in the Contents, has a corresponding parts list. Index numbers are used to key each part in the exploded views to the parts list and service instructions in preceding sections of this manual.

P-3. The PART NUMBER column in the parts list gives the part number which can be used to order replacement parts. Since this section covers more than one model, and not all detail parts are used on a particular model, the words "not used" may appear in this column. If more than one part number is listed for the same index number, application information will be given in the DESCRIPTION column. Complete information on the identification tag (111, figure P-1 or P-2) should be included with all parts orders (see figure 1-1).

P-4. The DESCRIPTION column gives the part nomenclature used, not only in the list but also in the service instructions. If more than one part number is listed for the same index number, application information will be given in parenthesis following the part name. Refer to Table 1-2 for more information about parts variations for different models.

P-5. The QTY column designates the number of parts used at the location defined by the index number. Letter symbols may be used in this column to designate specific information. The symbols are as follows:

- AR — As Required. This is used for selective fit parts, determined as necessary at assembly.
- NP — Not Procurable. Detail parts so designated are not procurable separately. When replacement is required, order the next higher assembly.

PARTS LIST FOR FIGURE P-1

INDEX NO.	PART NUMBER	DESCRIPTION	QTY
1	10-00-149-019	Nut	1
2	10-00-047-015	Washer	1
3	10-00-016-002	Seal, Oil	1
4	13-56-531-002	Yoke Assy, Rear (rear yoke)	1
	13-56-531-004	Flange Assy, Rear (rear flange)	1
5	13-00-035-001	• Deflector	1
6	13-56-031-002	• Yoke (rear yoke)	1
	13-56-031-004	• Flange (rear flange)	1
7	13-00-052-003	Plug, Pipe	2
8	13-00-183-008	Bolt (1987-88)	4
	13-00-183-017	Bolt and Washer Assy (1989 and later)	4
9	13-56-566-003	Cap Assy, Bearing	1
10	13-00-044-009	• Seal, Oil	1
11	Not used		

PARTS LIST FOR FIGURE P-1 (cont.)

INDEX NO.	PART NUMBER	DESCRIPTION	QTY
65	13-56-171-009	• Shaft, Output (rear yoke)	1
	13-56-171-012	• Shaft, Output (optional-rear yoke)	1
	13-56-171-013	• Shaft, Output (rear flange)	1
	13-56-171-014	• Shaft, Output (optional-rear flange)	1
66	13-56-089-001	Hub, Reduction	1
67	13-00-596-001	Fork Assy, Reduction	1
68	13-56-235-001	• Facing, Shift Fork	2
69	13-50-543-001	• Pin, Roller and Retainer Assy	1
70	13-50-040-002	• • Retainer	1
71	13-52-127-001	• • Roller, Cam	1
72	13-50-043-001	• • Pin	1
73	13-00-096-001	• Fork, Reduction	1
74	Not used		
75	Not used		
76	Not used		
77	Not used		
78	Not used		
79	Not used		
80	Not used		
81	13-56-099-005	Cam, Electric Shift 1356-099-007	1
82	13-56-156-005	Spring, Torsion	1
83	13-56-053-005	Spacer	1
84	13-56-122-006	Shaft, Shift	1
85	13-00-044-009	Seal, Oil	1
86	13-00-139-009	Ring, Retaining	1
87	13-56-659-004	Carrier Assy, Complete	1
88	13-00-139-012	Ring, Retaining	1
89	13-56-162-002	Gear, Ring	1
	13-56-162-003	Gear, Ring (optional)	1
90	Not used		
91	10-00-149-019	Nut	1
92	10-00-047-015	Washer	1
93	10-00-016-002	Seal, Oil	1
94	13-56-531-001	Yoke Assy, Front	1
95	13-00-035-001	• Deflector	1
96	13-56-031-001	• Yoke	1
97	13-56-171-008	Shaft, Output	1
	13-56-171-011	Shaft, Output (optional)	1
98	13-00-072-001	Barb, Breather	1
99	Not used		
100	Not used		
101	Not used		
102	13-56-565-006	Case Assy, Transfer	1
103	13-00-044-009	• Seal, Oil	1
104	T86-7-1/2	• Ring, Retaining	1
105	13-45-130-001	• Bearing, Ball	1
106	13-00-139-010	• Ring, Retaining	1
107	13-00-130-001	• Bearing, Ball	1
108	Not used		
109	13-00-043-005	• Pin Dowel	2
110	13-56-065-008	• Case, Transfer	1
111	13-56-199-XXX	Tag, Identification	1

PARTS LIST FOR FIGURE P-1 (cont.)

INDEX NO.	PART NUMBER	DESCRIPTION	QTY
12	13-56-014-002	• Plate, Speed.	1
13	13-00-146-003	• Bolt, Stud	1
14	13-56-066-005	• Cap, Bearing	1
15	0011505117	Bolt	1
16	0011503949	Bolt	3
17	0011505117	Bolt	2
18	13-56-056-003	Bracket, Wiring Harness	1
19	13-50-640-003	Sensor and O-ring Assy	1
20	13-50-140-002	• Sensor, Speed	1
21	10-00-141-014	• O-/Ring	1
22	13-506-640-003	Motor Assy	1
23	13-56-053-003	Retainer, Speedo Gear	1
24	10-00-109-001	Ball, Speedo Gear	1
25	T18-169	Gear, Speedo (7 tooth)	1
	T18-169D	Gear, Speedo (8 tooth)	1
26	13-00-139-027	Ring, Snap	1
27	13-00-183-008	Bolt (1987-88)	12
	13-00-183-017	Bolt (1989 and later)	12
28	13-56-539-004	Cover Assy, Transfer Case	1
29	13-45-130-001	• Bearing, Ball	1
30	4840J	• Bearing, Needle	1
31	13-00-044-001	• Seal, Oil	1
32	13-00-127-002	• Bearing, Sleeve	1
33	13-00-149-002	• Nut	3
34	13-56-640-002	• Coil Assy, Clutch	1
35	13-56-039-008	• Cover, Transfer Case	1
36	10-00-012-002	Magnet	1
37	13-50-156-002	Spring, Return	1
38	10-00-139-027	Ring, Snap	1
39	13-56-212-002	Housing, Clutch	1
40	13-56-090-002	Hub, Shift Collar	1
41	13-56-589-002	Lockup Assy, 2W-4W	1
42	10-00-139-041	• Ring, Retaining	1
43	13-56-089-002	• Hub, Lockup	1
44	13-50-156-007	• Spring, Sleeve Return	1
45	13-56-055-003	• Collar, Lockup	1
46	13-50-100-001	Rail, Shift	1
47	13-56-596-004	Fork Assy, Shift, 2W-4W	1
48	13-45-235-001	• Facing, Shift Fork	2
49	10-45-139-004	Ring, Retaining	1
50	13-45-193-005	Washer	1
51	13-56-144-003	Sprocket, Drive	1
52	13-56-144-002	Sprocket, Driven	1
53	13-45-143-002	Chain, Drive	1
54	13-56-671-005	Shaft and Pump Assy (rear yoke)	1
	13-56-671-006	Shaft and Pump Assy (rear flange)	1
55	13-45-183-003	• Bolt, Hex Head	4
56	13-56-056-004	• Retainer, Pump	1
57	13-45-039-005	• Cover, Pump, Rear	1
58	13-45-056-005	• Clamp, Hose	1
59	13-56-034-001	• Coupling, Hose	1
60	13-45-238-001	• Strainer, Oil	1
61	13-45-097-004	• Housing, Pump	1
62	13-45-043-007	• Pin, Pump	2
63	13-45-156-004	• Spring, Pump Pin	1
64	13-45-039-007	• Cover, Pump, Front	1

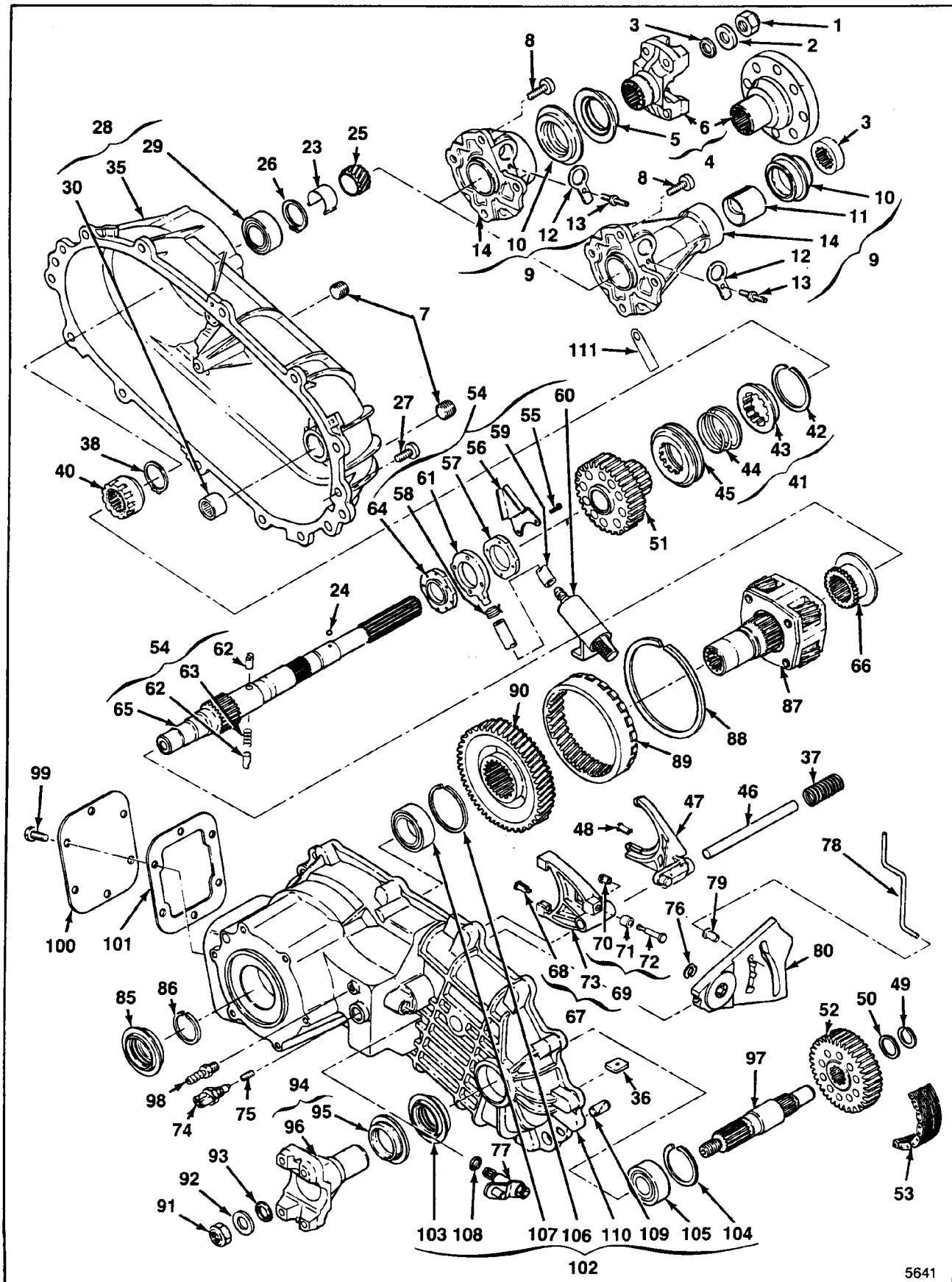

Figure P-2. Transfer Case Assembly, Mechanical Shift

PARTS LIST FOR FIGURE P-2

INDEX NO.	PART NUMBER	DESCRIPTION	QTY
1	10-00-149-019	Nut (rear yoke/flange)	1
2	10-00-047-015	Washer (rear yoke/flange)	1
3	13-56-016-001	Seal, Oil (rear spline)	1
	13-00-016-002	Seal, Oil (rear yoke/flange)	1
4	13-56-531-002	Yoke Assy, Rear (rear yoke)	1
	13-56-531-004	Flange Assy, Rear (rear flange)	1
5	13-00-035-001	• Deflector (rear yoke/flange)	1
6	13-56-031-002	• Yoke (rear yoke)	1
	13-56-031-004	• Flange (rear flange)	1
7	13-00-052-003	Plug, Pipe	2
8	13-00-183-008	Bolt (1987-88)	4
	13-00-183-017	Bolt and Washer Assy (1989 and later)	4
9	13-56-566-008	Extension Assy (rear spline) 1356-566-012	1
	13-56-566-003	Cap Assy, Bearing (rear yoke/flange)	1
10	13-00-044-006	• Seal, Oil (rear spline) 1300-044-014	1
	13-00-044-009	• Seal, Oil (rear yoke/flange)	1
11	13-56-127-001	• Bushing (rear spline)	1
12	13-56-014-002	• Plate, Speedo	1
13	13-00-146-003	• Bolt, Stud	1
14	13-56-066-007	• Extension (rear spline)	1
	13-56-066-005	• Cap, Bearing (rear yoke/flange)	1
15	Not used		
16	Not used		
17	Not used		
18	Not used		
19	Not used		
20	Not used		
21	Not used		
22	Not used		
23	13-56-053-003	Retainer, Speedo Gear	1
24	10-00-109-001	Ball, Speedo Gear	1
25	T18-169	Gear, Speedo (7 tooth)	1
	T18-169D	Gear, Speedo (8 tooth)	1
26	13-00-139-027	Ring, Snap	1
27	13-00-183-008	Bolt (1987-88)	12
	13-00-183-017	Bolt and Washer Assy (1989)	12
28	13-56-539-003	Cover Assy, Transfer Case	1
29	13-45-130-001	• Bearing, Ball = 6207ZNBRT	1
30	4840J	• Bearing, Needle = 62012	1
31	Not used		
32	Not used		
33	Not used		
34	Not used		
35	13-56-039-007	• Cover, Transfer Case	1
36	10-00-012-002	Magnet	1
37	13-50-156-002	Spring, Return	1
38	13-00-139-027	Ring, Snap	1
39	Not used		
40	13-56-090-004	Hub, Shift Collar	1
41	13-56-589-001	Lockup Assy, 2W-4W	1
42	10-00-139-041	• Ring, Retaining	1
43	13-506-089-002	• Hub, Lockup	1
44	13-50-156-007	• Spring, Sleeve Return	1
45	13-56-055-001	• Collar, Lockup	1
46	13-50-100-001	Rail, Shift	1
47	13-56-596-004	Fork Assy, Shift, 2W-4W	1
48	13-56-235-001	• Facing, Shift Fork	2

PARTS LIST FOR FIGURE P-2 (cont.)

INDEX NO.	PART NUMBER	DESCRIPTION	QTY
49	13-45-139-004	Ring, Retaining	1
50	13-45-193-005	Washer	1
51	13-56-144-003	Sprocket, Drive	1
52	13-56-144-002	Sprocket, Driven	1
53	13-45-143-002	Chain, Drive	1
54	13-56-671-004	Shaft and Pump Assy (rear spline)	1
	13-56-671-005	Shaft and Pump Assy (rear yoke)	1
	13-56-671-006	Shaft and Pump Assy (rear flange)	1
55	13-45-183-003	• Bolt	4
56	13-56-056-004	• Retainer, Pump	1
57	13-45-039-005	• Cover, Pump, Rear	1
58	13-45-056-005	• Clamp, Hose	1
59	13-56-034-001	• Coupling, Hose	1
60	13-45-238-001	• Strainer, Oil	1
61	13-45-097-004	• Housing, Pump	1
62	13-45-043-007	• Pin, Pump	2
63	13-45-156-004	• Spring, Pump Pin	1
64	13-45-039-007	• Cover, Pump, Front	1
65	13-56-171-007	• Shaft, Output (rear spline)	1
	13-56-171-010	• Shaft, Output (optional-rear spline)	1
	13-56-171-009	• Shaft, Output (rear yoke)	1
	13-56-171-012	• Shaft, Output (optional-rear yoke)	1
	13-56-171-013	• Shaft, Output (rear flange)	1
	13-56-171-014	• Shaft, Output (optional-rear flange)	1
66	13-56-089-001	Hub, Reduction	1
67	13-00-596-001	Fork Assy, Reduction	1
68	13-56-235-001	• Facing, Shift Fork	2
69	13-50-543-001	• Pin, Roller and Retainer Assy	1
70	13-50-040-002	•• Retainer	1
71	13-52-127-001	•• Roller, Cam	1
72	130-50-043-001	•• Pin	1
73	13-00-096-001	• Fork, Reduction	1
74	13-00-140-007	Switch, 4WD Indicator	1
75	13-00-183-019	Setscrew	1
76	13-45-056-002	Ring, Klip	1
77	13-56-589-007	Lever, Shaft and Pin Assy	1
78	13-56-156-002	Spring, Assist	1
79	13-56-127-008	Bushing, Assist	1
80	13-56-099-006	Cam, Shift	1
81	Not used		
82	Not used		
83	Not used		
84	Not used		
85	13-00-044-009	Seal, Oil	1
86	13-00-139-009	Ring, Retaining	1
87	13-56-659-005	Carrier Assy, Complete (with PTO)	1
	13-56-659-004	Carrier Assy, Complete (without PTO) = 13-56-659-007	1
88	13-00-139-012	Ring, Retaining	1
89	13-56-162-002	Gear, Ring	1
	13-56-162-003	Gear, Ring (optional)	1
90	13-56-070-002	Gear, PTO (with PTO)	1
91	10-00-149-019	Nut	1
92	10-00-047-015	Washer	1
93	10-00-016-002	Seal, Oil	1
94	13-56-531-001	Yoke Assy, Front	1

PARTS LIST FOR FIGURE P-1 (cont.)

INDEX NO.	PART NUMBER	DESCRIPTION	QTY
95	13-00-035-001	• Deflector	1
96	13-56-031-001	• Yoke	1
97	13-56-171-008	Shaft, Output	1
	13-56-171-011	Shaft, Output (optional)	1
98	13-00-072-001	Barb, Breather	1
99	10-00-183-041	Bolt (with PTO)	6
100	13-00-191-010	Cover, PTO (with PTO)	1
101	13-00-045-001	Gasket (with PTO)	1
102	13-56-565-007	Case Assy, Transfer	1
103	13-00-044-009	• Seal, Oil	1
104	T86-7-1/2	• Ring, Retaining	1
105	13-45-130-001	• Bearing, Ball = <i>6207ZNB</i>	1
106	13-00-139-010	• Ring, Retaining	1
107	13-00-130-001	• Bearing, Ball	1
108	13-00-016-001	• Seal, Oil	1
109	13-00-043-005	• Pin Dowel	2
110	13-56-065-009	• Case, Transfer (with PTO)	1
	13-56-065-007	• Case, Transfer (without PTO)	1
111	13-56-199-026	Tag, Identification	1