



NISSAN
RL4R02A

INDEX

<i>REPAIR NOTES</i>	4
<i>ON-VEHICLE SERVICE</i>	8
<i>REMOVAL & INSTALLATION</i>	14
<i>DISASSEMBLY</i>	17
<i>COMPONENTS</i>	22
<i>VALVE BODIES</i>	26
<i>ASSEMBLY</i>	50
<i>TROUBLE SHOOTING DIAGNOSIS</i>	69
<i>INSPECTION</i>	82
<i>SPECIFICATIONS</i>	89
<i>BULLETINS</i>	92

AUTOMATIC TRANSMISSION SERVICE GROUP
18639 SW 107TH AVENUE
MIAMI, FLORIDA 33157
(305) 670-4161

Copyright © ATSG 2005



*Updated
April, 2004*

INTRODUCTION

NISSAN RL4F02A

The RL4F02A is a four speed front wheel drive, hydraulic controlled, automatic transaxle with an electronic controlled torque converter clutch solenoid and overdrive cancel solenoid. This manual contains the procedures necessary to disassemble, rebuild all components, reassemble and diagnose this unit.

*We wish to thank Nissan Corporation
for the information and illustrations
that have made this booklet possible.*

No part of any ATSG publication may be reproduced, stored in any retrieval system or transmitted in any form or by any means, including but not limited to electronic, mechanical, photocopying, recording or otherwise, without *written* permission of Automatic Transmission Service Group. This includes all text illustrations, tables and charts.

*The information and part numbers contained in this booklet have
been carefully compiled from industry sources known for their
reliability, but ATSG does not guarantee its accuracy.*

Copyright © ATSG 2004

DALE ENGLAND
FIELD SERVICE CONSULTANT

WAYNE COLONNA
TECHNICAL SUPERVISOR

PETER LUBAN
TECHNICAL CONSULTANT

JON GLATSTEIN
TECHNICAL CONSULTANT

ROLAND ALVAREZ
TECHNICAL CONSULTANT

GERALD CAMPBELL
TECHNICAL CONSULTANT

JIM DIAL
TECHNICAL CONSULTANT

ED KRUSE
TECHNICAL CONSULTANT

GREGORY LIPNICK
TECHNICAL CONSULTANT

DAVID CHALKER
TECHNICAL CONSULTANT

JERRY GOTT
TECHNICAL CONSULTANT

MIKE SOUZA
TECHNICAL CONSULTANT

AUTOMATIC TRANSMISSION SERVICE GROUP
18639 SW 107TH AVENUE
MIAMI, FLORIDA 33157
(305) 670-4161

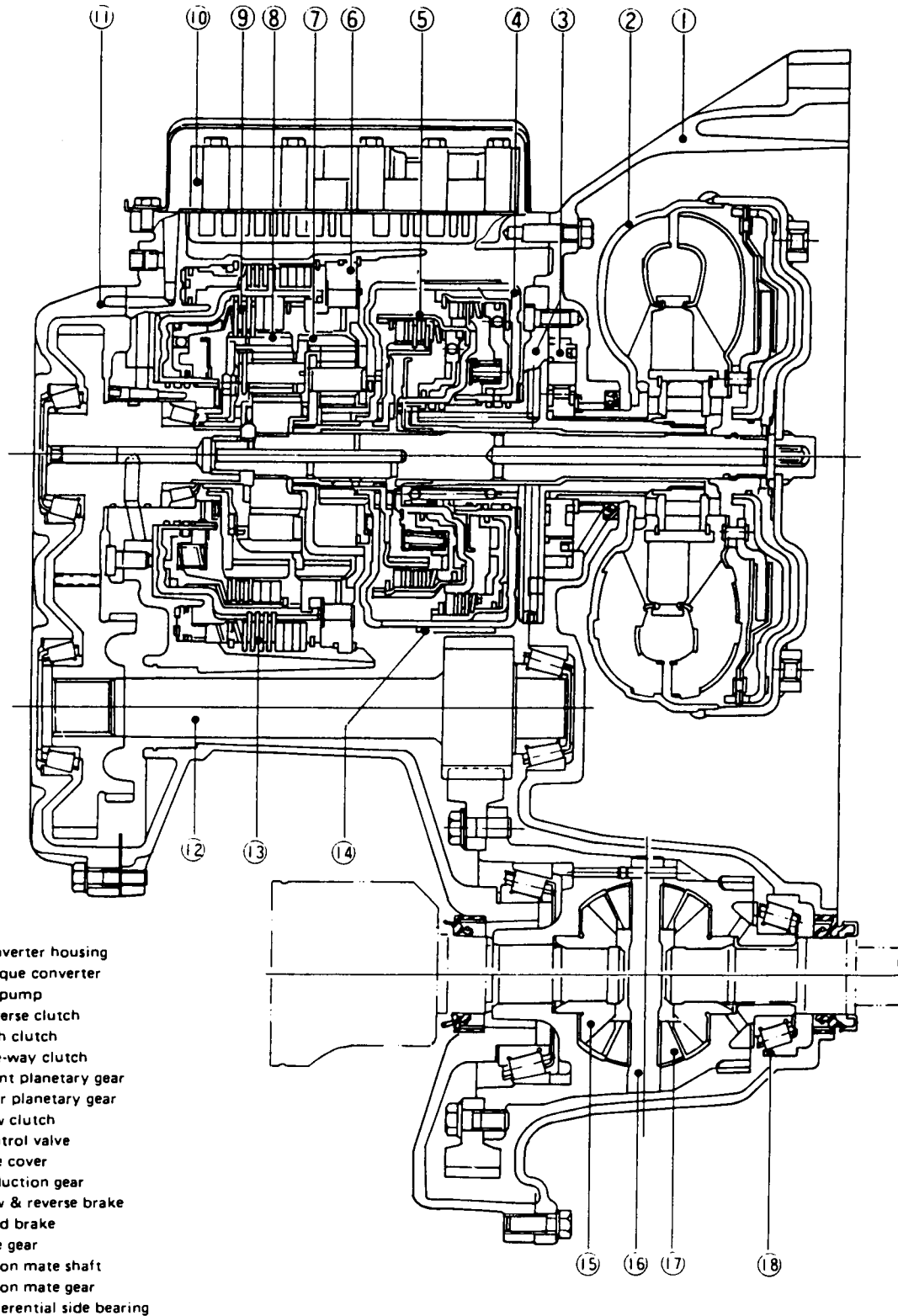

ProCarManuals.com

AUTOMATIC TRANSMISSION SERVICE GROUP

Repair Notes

- Before proceeding with disassembly, thoroughly clean the outside of the transmission. It is important to prevent the internal parts of the transmission from becoming contaminated by dirt or other foreign matter.
- Disassembly should be done in a clean work area.
- Use a nylon cloth or paper towel for wiping parts clean. Common shop rags can leave lint that might interfere with the transmission's operation.
- When disassembling parts, be sure to place them in order in parts rack so they can be put back in the unit in their proper positions.
- All parts should be carefully cleaned with a general purpose, non-flammable solvent before inspection or reassembly.
- Gaskets, seals, and O-rings should be replaced. It is also very important to perform functional tests whenever it is designated.
- The valve body contains many precision parts and requires extreme care when parts are

removed and serviced. Place removed parts on a parts rack so they can be put back in the valve body in the same positions and sequences. Care will also prevent springs and small parts from becoming scattered or lost.

- Before assembly, apply a coat of recommended A.T.F. to all parts. Petroleum jelly may be applied to O-rings and seals. Do not use any grease.
- Care should be taken to avoid damaging O-rings, seals and gaskets when assembling.

Abbreviations used throughout this section stand for the following:

- A.T.F. Automatic transmission fluid
- D₁ Drive range 1st gear
- D₂ Drive range 2nd gear
- D₃ Drive range 3rd gear
- D₄ Drive range 4th gear
- O.D. Overdrive
- 1₂ 1 range 2nd gear
- 1₁ 1 range 1st gear

Control Valve

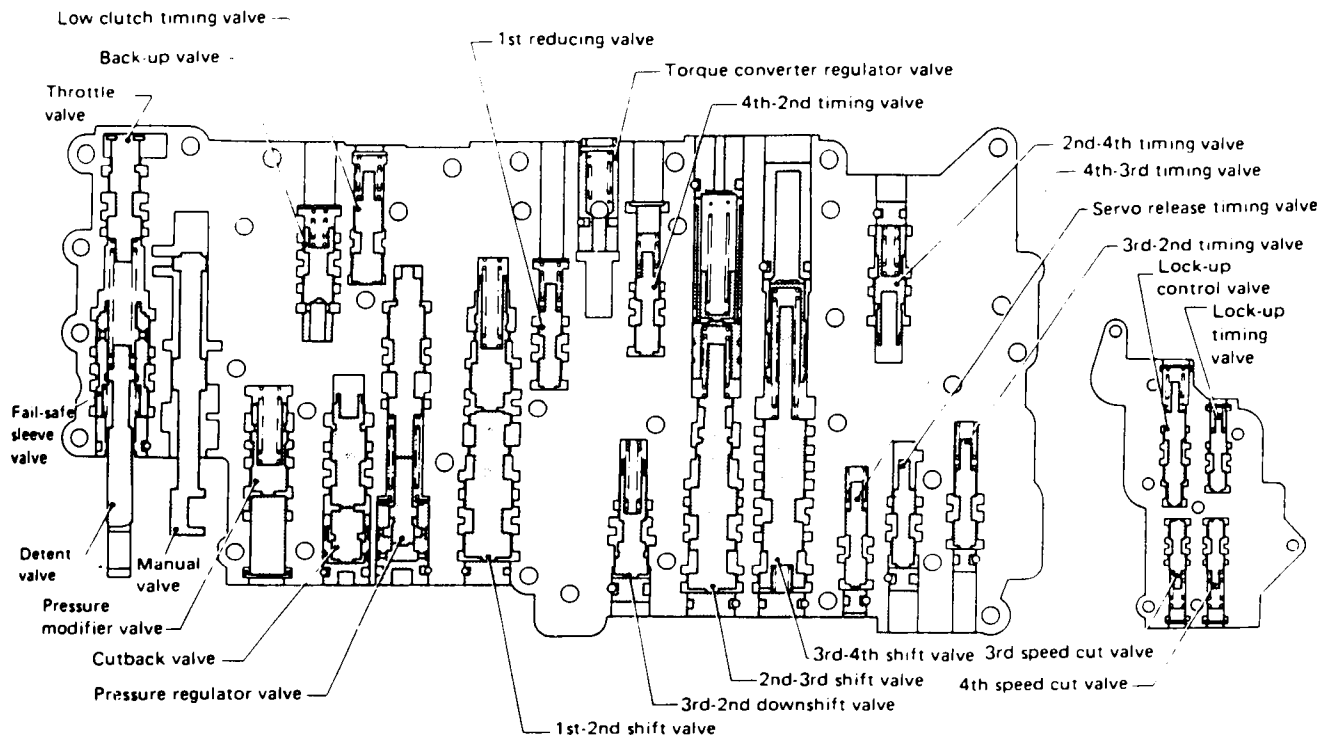

In regard to the description of each component, refer to Control Valve Body.

Oil Channel

Oil channels which connect components are located in areas shown below.

OIL CHANNELS IN OIL PUMP COVER

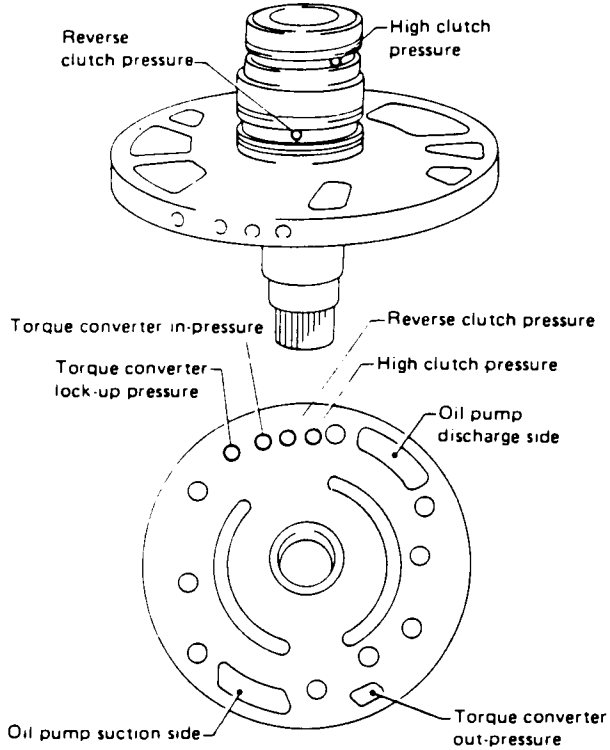

OIL CHANNELS IN TRANSMISSION CASE

Control valve attaching side

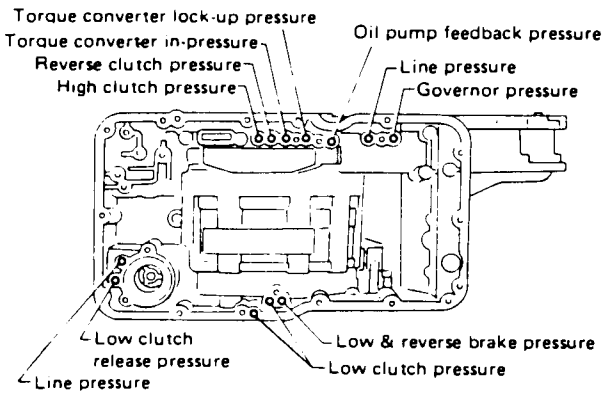

Converter housing attaching side

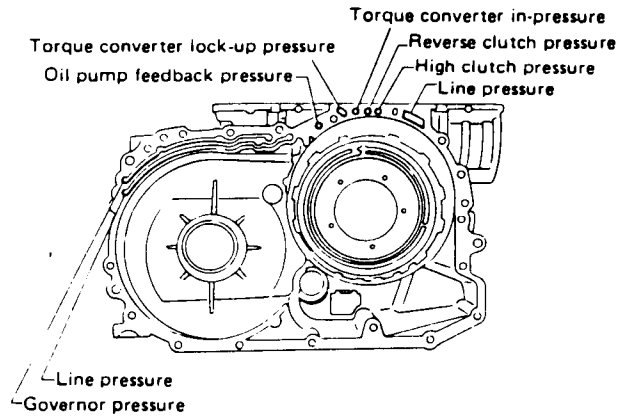

OIL CHANNELS IN CONVERTER HOUSING

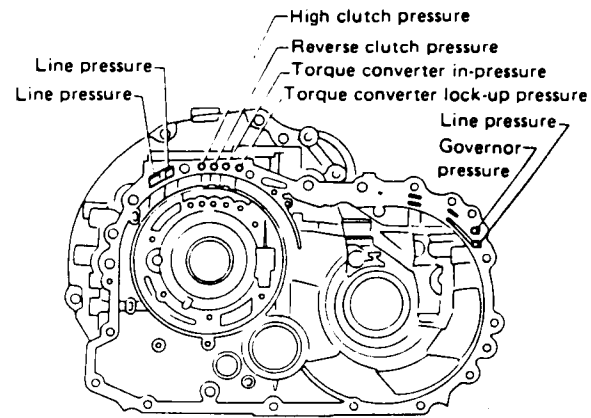



Technical Service Information

Mechanical Operation

Each part operates as shown in the following table at each gear position.

RL4F02A

Range	Gear ratio	Reverse clutch	High clutch	Low clutch	Band servo		Low & reverse brake	One-way clutch	Parking pawl	Lock-up
					Operation	Release				
Park	-								on	
Reverse	2.272	on					on			
Neutral	-									
Drive	D ₁ Low	2.785		on				on		
	D ₂ Second	1.545		on	on					
	D ₃ Top (3rd)	1.000		on	on	(on)	on			
	D ₄ O.D. (4th)	0.694		on		on				on
2	2 ₁ Low	2.785		on				on		
	2 ₂ Second	1.545		on	on					
1	1 ₁ Low	2.785		on			on	on		
	1 ₂ Second	1.545		on	on					

AUTOMATIC TRANSMISSION SERVICE GROUP

Hydraulic Control Circuits

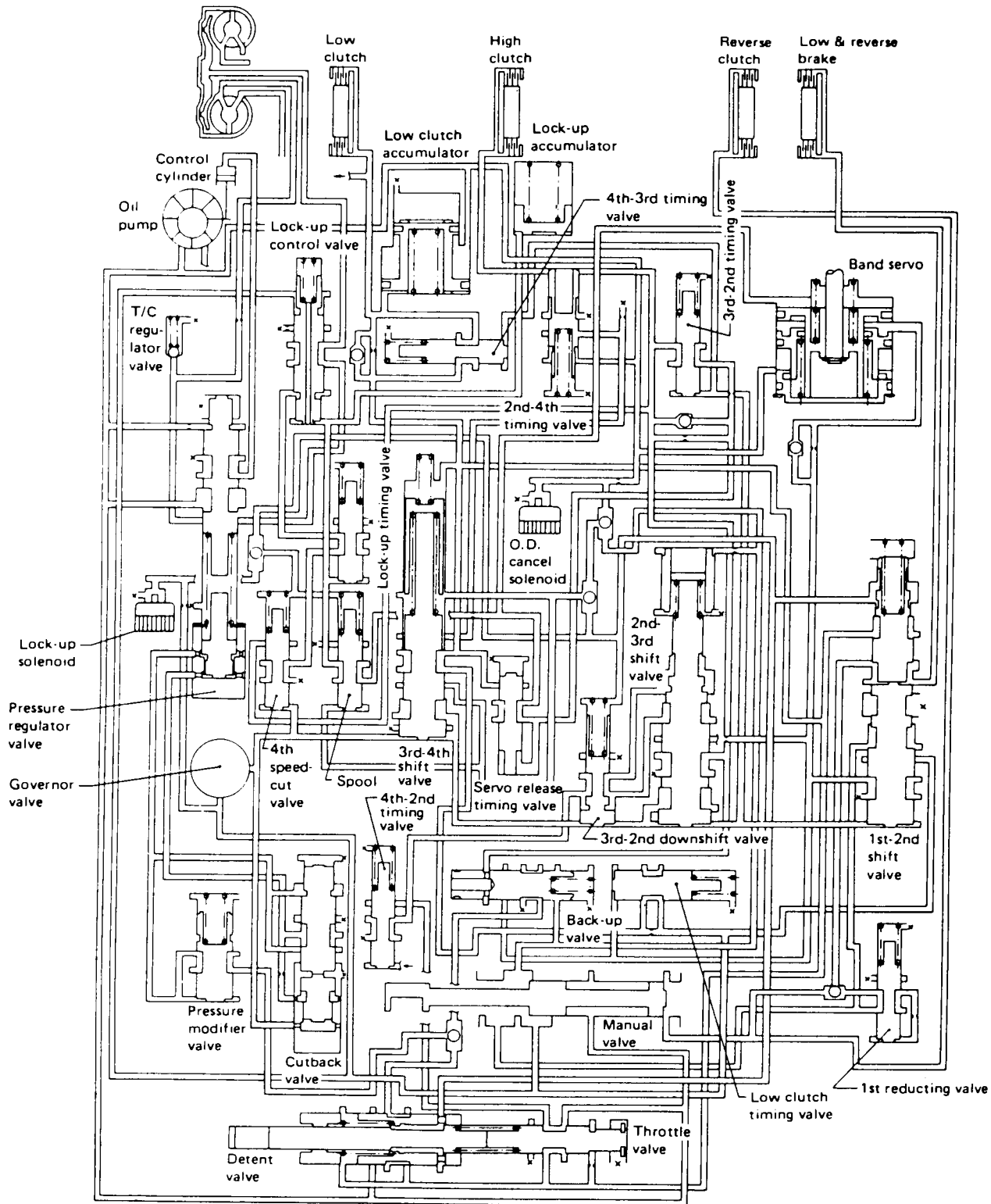

AUTOMATIC TRANSMISSION SERVICE GROUP

Fluid Level

Use the dipstick to check the fluid level at "HOT" fluid temperatures [50 to 80°C (122 to 176°F)] after the vehicle has been driven approximately 10 minutes. The fluid level can also be checked at "COLD" fluid temperatures [30 to 50°C (86 to 122°F)].

1. Park the vehicle on a level surface and set the parking brake.
2. Start the engine and then move the selector lever through each gear range, ending in "P".
3. Check the fluid level with the engine idling. (If the vehicle has not been driven for some time and the outside temperature is below 30°C (86°F), a "COLD" fluid temperature can be obtained by warming the engine up completely.)
4. Remove the dipstick and clean it with lint-free paper. Reinsert it into the charging pipe as far as it will go.
5. Remove the dipstick and note the reading. If the fluid temperature is "HOT", the level should be in the hot range (in the shaded area). If it is "COLD", the level should be in the cold range (within the cutout portion).

• Front side

Hot: 50 - 90°C (122 - 194°F)

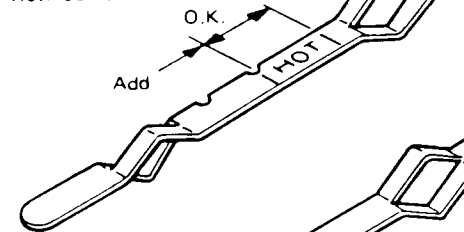

• Reverse side

Cold: 30 - 50°C (86 - 122°F)

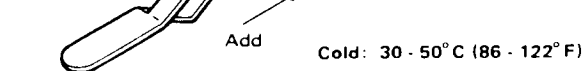

Keep the fluid at the proper level.

- Overfilling may blow off the fluid or damage the transaxle.
- Underfilling may cause the clutches to slip, resulting in damage to them.

Control Valve

1. Remove the battery and its bracket.
2. Remove the air cleaner, air flow meter, air damper and solenoid valves all as an assembly.

Be careful not to damage the air flow meter.

3. Disconnect control cable and throttle wire then remove throttle lever.

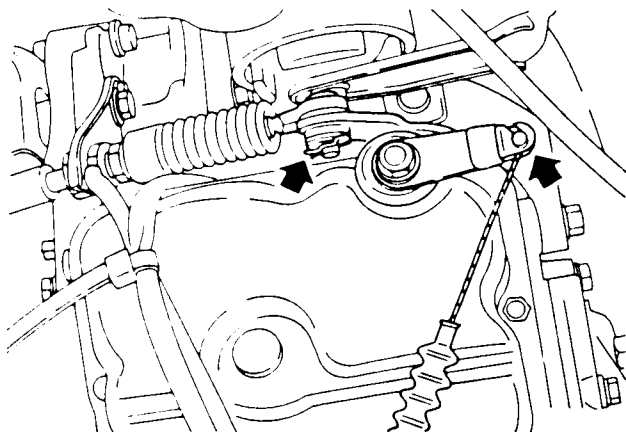

4. Remove control cylinder.
5. Disconnect harness connector on control valve and remove control valve assembly.

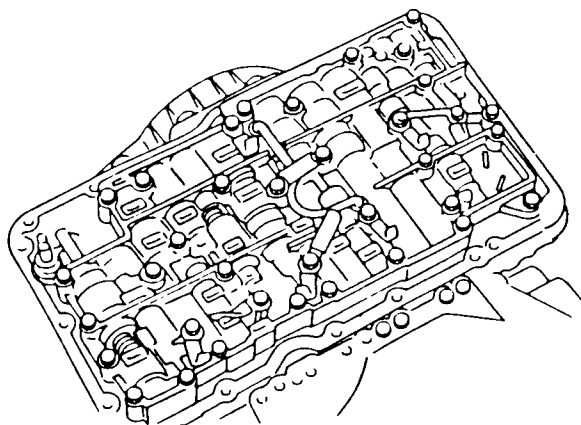

Be careful not to drop manual valve out of valve body.

6. Disassemble, inspect and assemble control valve assembly. Refer to Control Valve Body.

- Set manual shaft at Neutral, then align manual plate with groove in manual valve of control valve assembly.

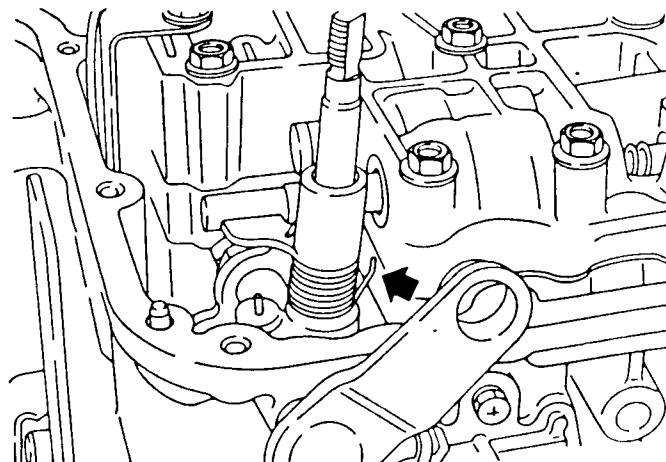

- After installing control valve to transmission case, make sure that control lever can be moved to all positions.

ON-VEHICLE SERVICE

Throttle Wire Adjustment

- Loosen throttle wire double nuts A and B on throttle valve side.

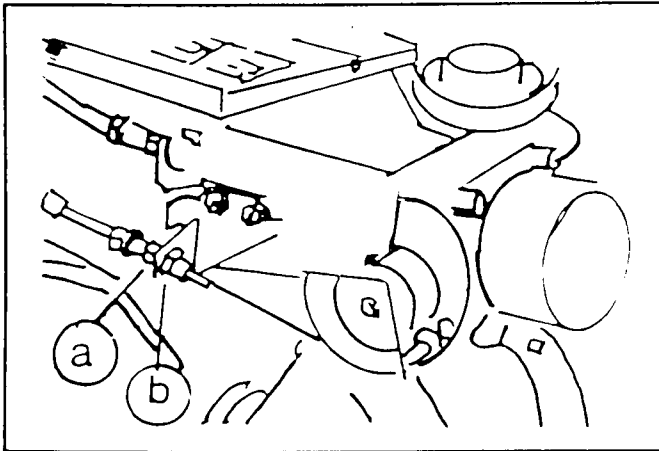

- With throttle drum set at "P₁" (full-throttle), pull fitting "Q" fully in direction T and tighten nut "B" by hand until it contacts bracket "S".

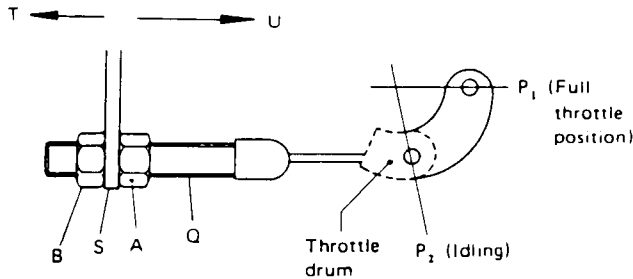

- Back off nut "B" 3/4 to 1-1/4 revolutions in direction "T", then tighten nut "A" securely. Throttle drum should stay at "P₁".

If throttle wire stroke is improperly adjusted, the following problems may arise.

- When full-throttle position "P₁" of throttle drum is closer to direction T, the shift schedule will be as shown by ② in the figure below, and the kickdown range will greatly increase.

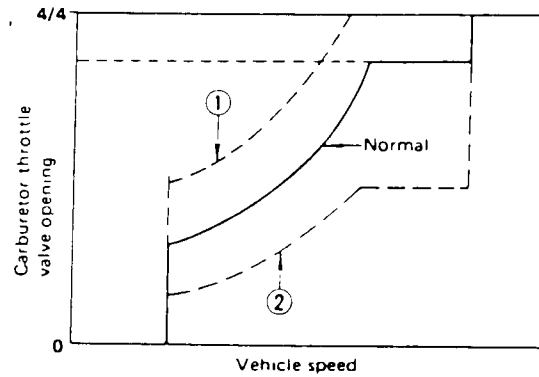

- When full-open position "P₁" of throttle drum is closer to direction U, the shift schedule will be as shown by ① in figure above, and kick-down range will not occur.

Control Cable Adjustment

Move the selector lever from the "P" range to "1" range. You should be able to feel the detents in each range.

If the detents cannot be felt or the pointer indicating the range is improperly aligned, the control cable needs adjustment.

Adjust control cable as follows:

1. Release the parking brake.
2. Remove control cable from selector lever.

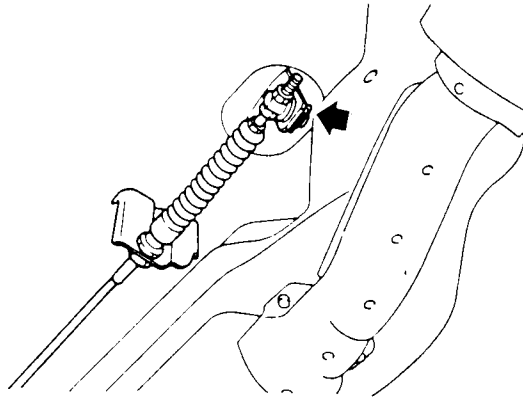

3. Pull the control cable in order to place the manual lever in "P" range.

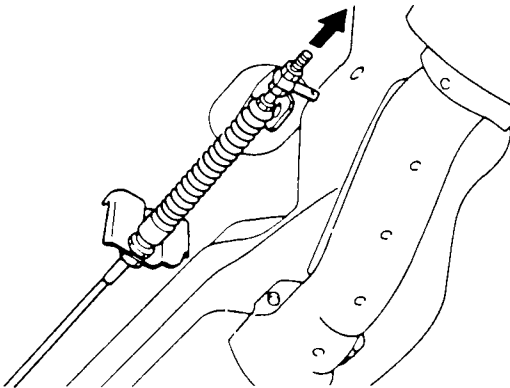

4. Make sure that drive shafts do not turn. To do this, try to rotate both R.H. and L.H. drive shafts in the same direction.
5. Loosen trunnion nuts A and B.

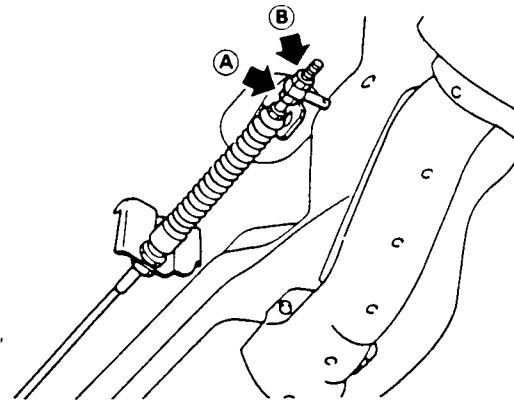

6. Make sure that control lever can move smoothly and without any sliding noise, and then place selector lever in "P" range.
7. Connect the control cable to control lever.

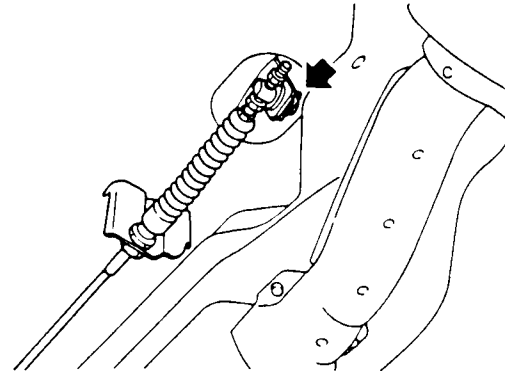

8. Tighten nuts A and B by hand and then tighten them to the specified torque.

Governor Shaft

1. Remove the battery.
2. Remove the air cleaner, air flow meter, air damper and solenoid valves as an assembly.
3. Remove governor cap.
4. Remove governor shaft securing bolt.

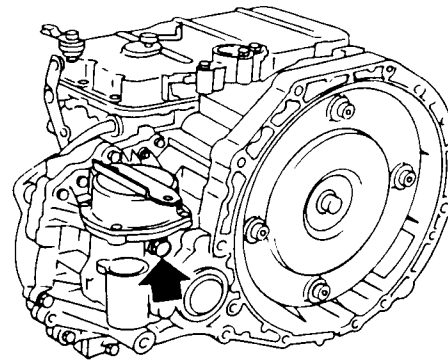

ON-VEHICLE SERVICE

Governor Shaft (Cont'd)

- Remove governor shaft assembly.

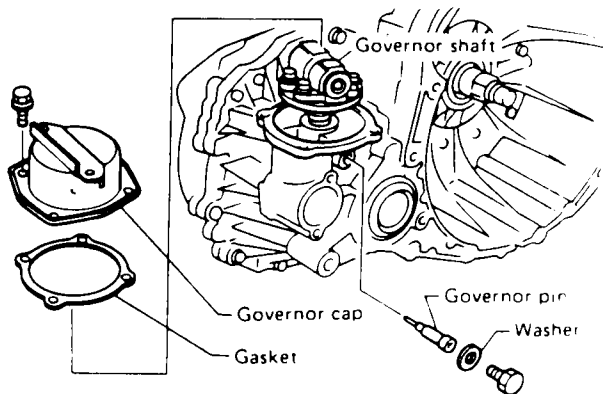

Inhibitor Switch Adjustment

- Remove the battery.
- Remove the air cleaner, air flow meter, air damper and solenoid valves as an assembly.
- Remove control cable end from unit.

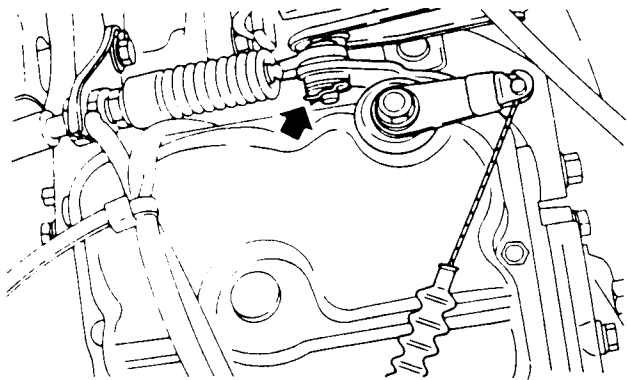

- Disconnect harness at connector, then remove inhibitor switch.

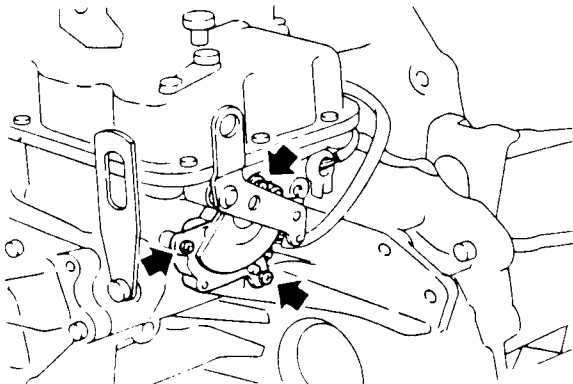

- Check continuity at "N", "P" and "R" ranges.

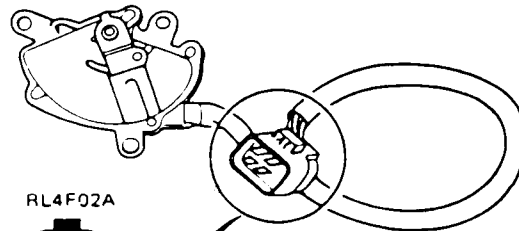

RL4F02A



Connector	1	2	3	4
Range				
N, P	○	○		
R			○	○

- With selector lever held in "Neutral", turn manual lever an equal amount in both directions to see if current flow ranges are nearly the same. (Current normally begins to flow before manual lever reaches an angle of 1.5° in either direction.)

If current flows outside normal range, or if normal flow range is out of specifications, properly adjust inhibitor switch.

Adjust inhibitor switch as follows:

- Loosen attaching screws.
- Set selector lever (manual shaft) at "N" position.
- Insert a pin into adjustment holes in both inhibitor switch and switch lever as near vertical as possible.

Pin dia.
4 mm (0.16 in)

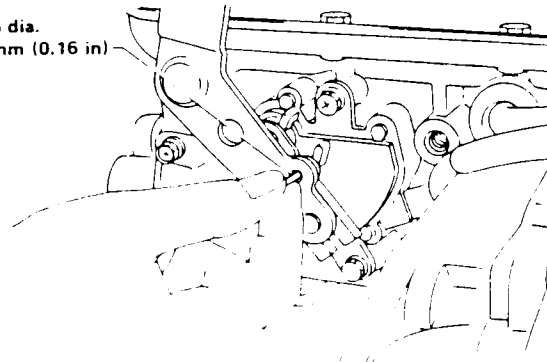

- Tighten screws.
- Recheck for continuity. If faulty, replace the switch.

ON-VEHICLE SERVICE

— Diff. Side Oil Seal Replacement —

1. Remove left drive shaft assembly. Refer to Drive Shaft in FA section.
2. Remove oil seal.

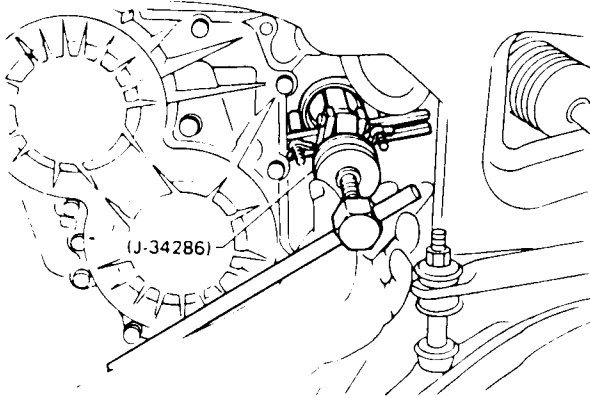

3. Apply coat of A.T.F. to oil seal surface, then drive new oil seal into place.

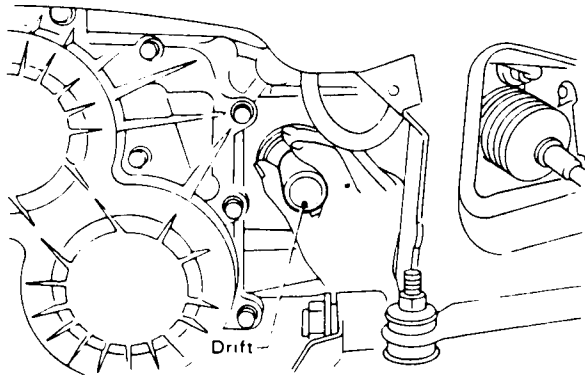

4. Install left drive shaft assembly. Refer to Drive Shaft in FA section.

Be extremely careful not to scratch oil seal when inserting drive shaft.

Removal

1. Remove transaxle with engine.
Refer to EM section.
2. Remove transaxle-to-engine bolts and draw out rear plate.
3. Remove bolts securing torque converter to drive plate.

Before removing torque converter, inscribe matching marks on two parts so that they may be replaced in their original positions during assembly.

- When connecting torque converter to transaxle, measure distance "A" to be certain that they are correctly assembled.

Distance "A":
17.5 - 20.0 mm (0.689 - 0.787 in)

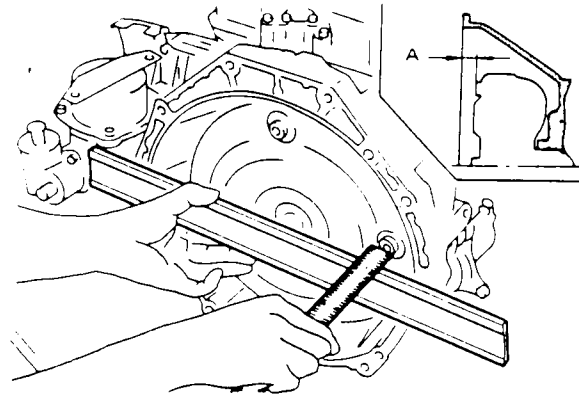

- Install transaxle to engine.
- Bolt converter to drive plate. Refer to photograph in Removal.
 - a. Align matching marks painted across both parts during disassembly.
 - b. Before installing torque converter securing bolts, apply locking sealer to threads of bolts.
- After converter is installed, rotate crankshaft several turns and check to be sure that transaxle rotates freely without binding.
- Adjust control cable. Refer to On-Vehicle Service.
- Check inhibitor switch for operation:
- Check fluid level in transaxle.
- Move hand lever through all positions to be sure that transaxle operates correctly.
With hand brake applied, run engine at idle. Without disturbing the above setting, move selector lever through "N" to "D", to "2", to "1" and to "R". A slight shock should be felt by hand gripping hand lever each time transaxle is shifted.
- Check to be sure that line pressure is correct.
To do this, refer to Line Pressure Test.
- Perform stall test.

Installation

- Drive plate runout
Maximum allowable runout:
0.5 mm (0.020 in)

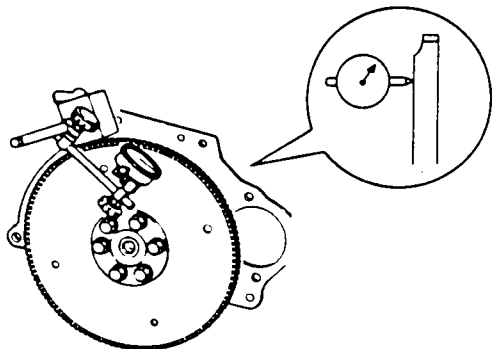

If this runout is out of allowance, replace drive plate and ring gear.

DISASSEMBLY

1. Drain A.T.F.
2. Remove torque converter.
3. Draw out input shaft.

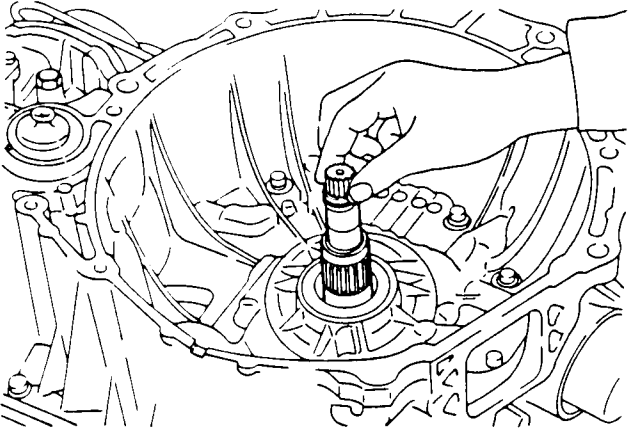

4. Remove control cylinder.

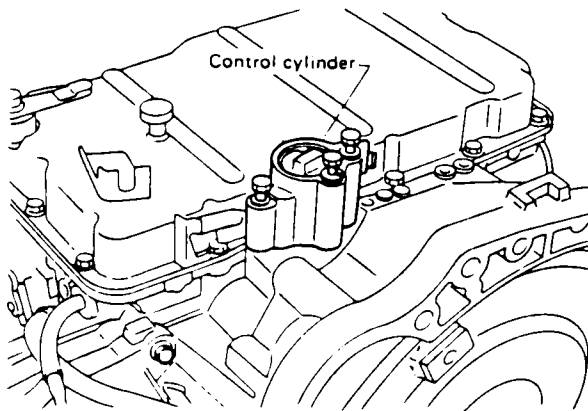

5. Remove throttle lever and valve cover.

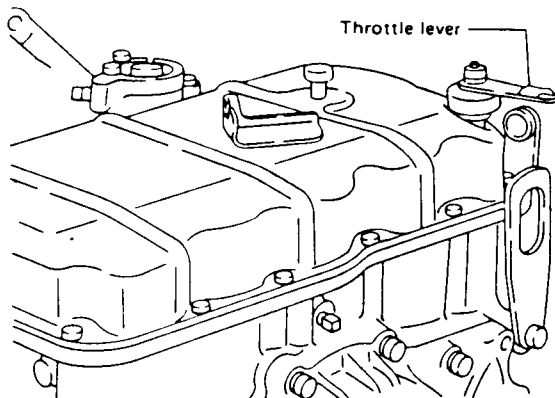

6. Disconnect harness connectors on control valve and remove control valve assembly.

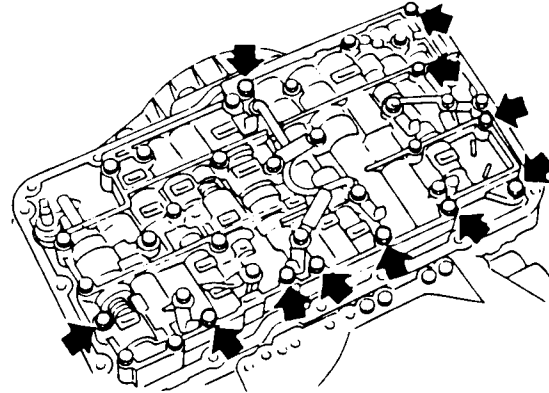

7. Remove terminal assembly.

CAUTION:

The terminal retrieving hooks will break if they are forced inward too far. Bend them gently inward while carefully pulling outward on the terminal. Do not pull on the wires.

DISASSEMBLY

9. Remove accumulator.

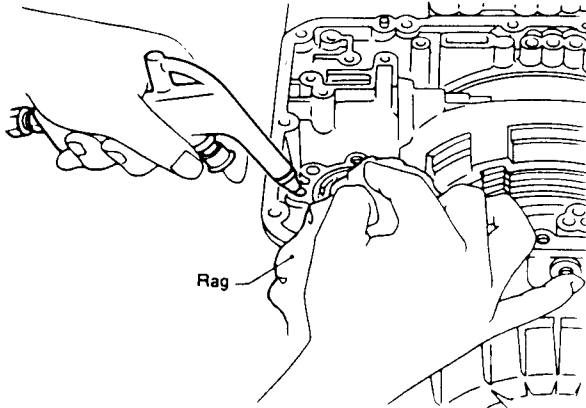

10. Remove side cover.

11. Remove output gear.

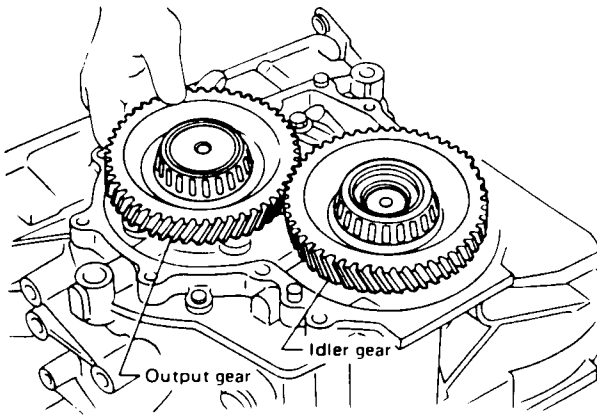

12. Draw out idler gear.

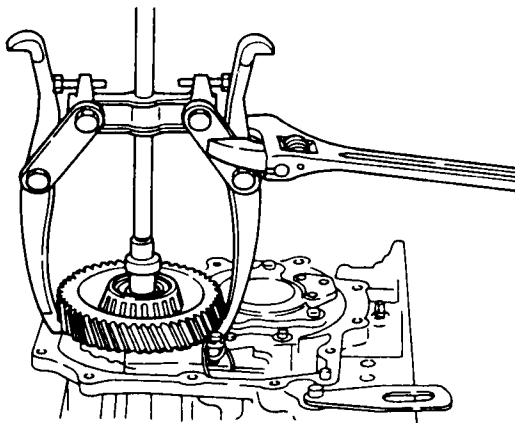

13. Remove parking pawl, return spring, pawl shaft and spacer.

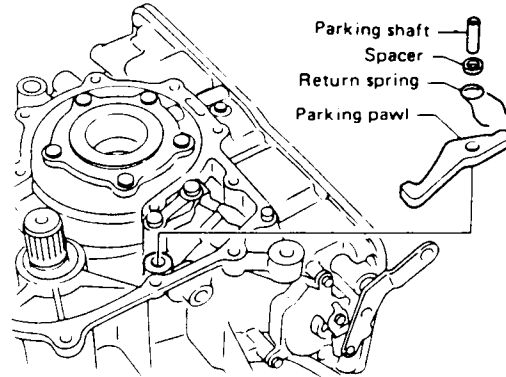

14. Remove speedometer case and speedometer gear.

15. Remove governor cap and pin, then draw out governor shaft assembly.

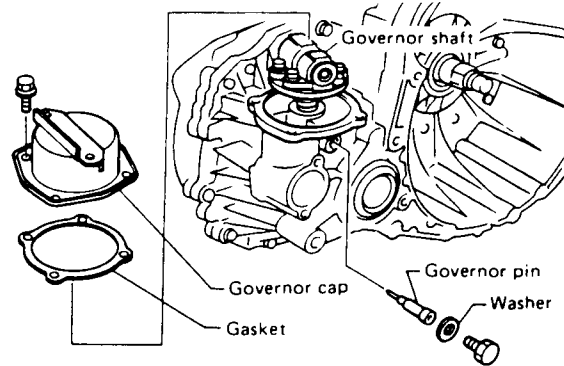

16. Put transmission assembly on wooden block and remove converter housing.

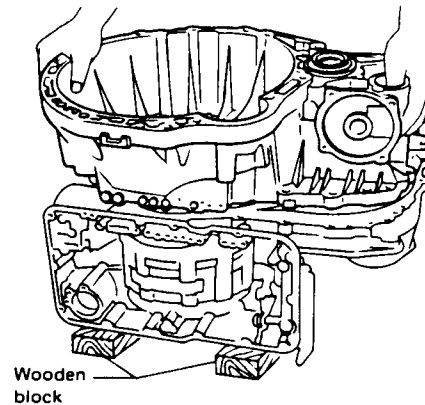

17. Remove final drive assembly and reduction pinion gear.

DISASSEMBLY

18. Remove oil strainer.

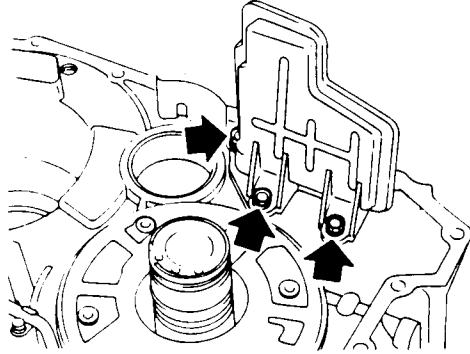

19. Remove diff. lubrication tube and diff. gutter.

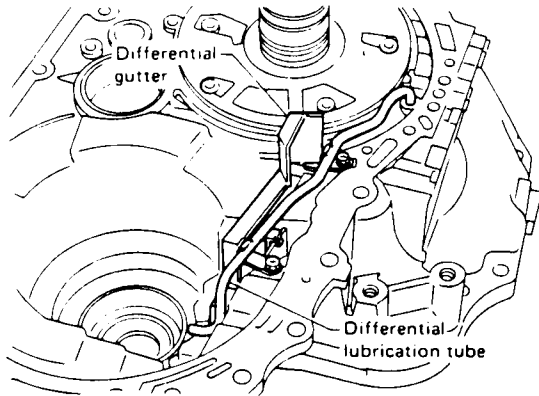

20. Loosen band brake stem lock nut, then back off piston stem.

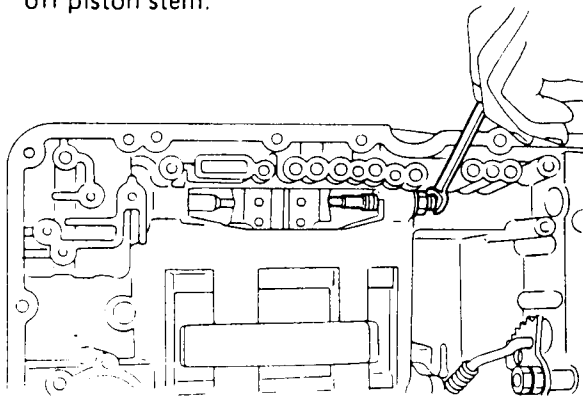

21. Remove brake band and high clutch & reverse clutch pack.

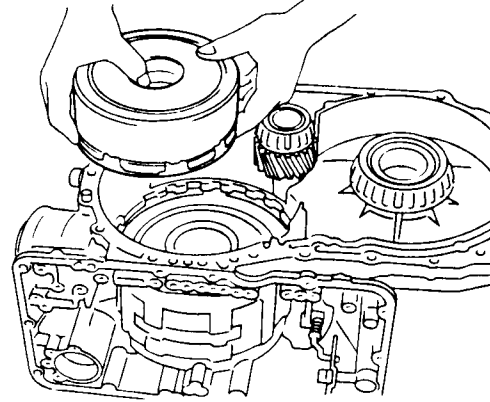

To prevent brake linings from cracking or peeling, do not stretch the flexible band unnecessarily. Before removing the brake band, always secure it with a clip as shown in the figure below.

Leave the clip in position after removing the brake band.

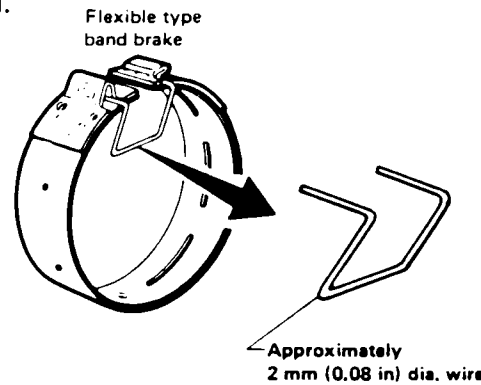

22. Remove one-way clutch, front carrier, rear carrier and low clutch as a set.

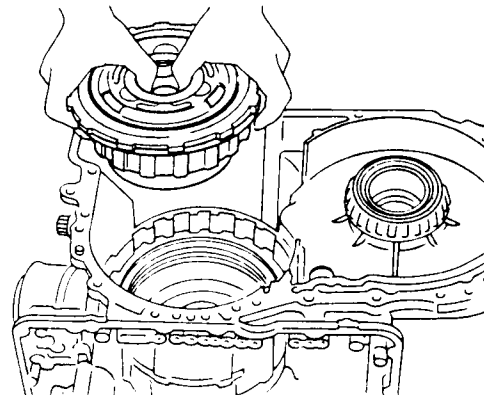

23. Remove low & reverse brake clutches, and detach low & reverse brake retainer snap ring.

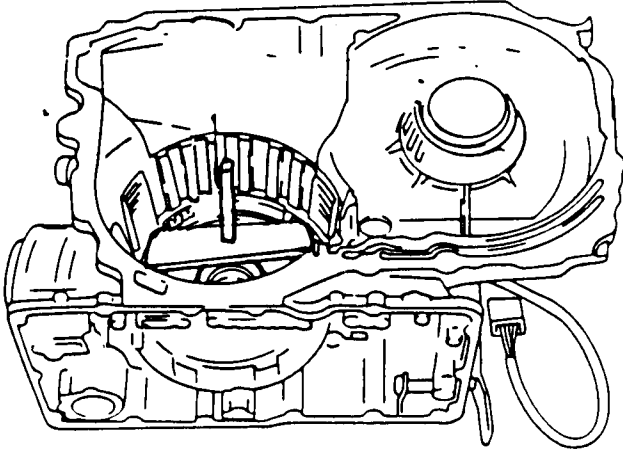

24. Remove low and reverse brake piston with compressed air.

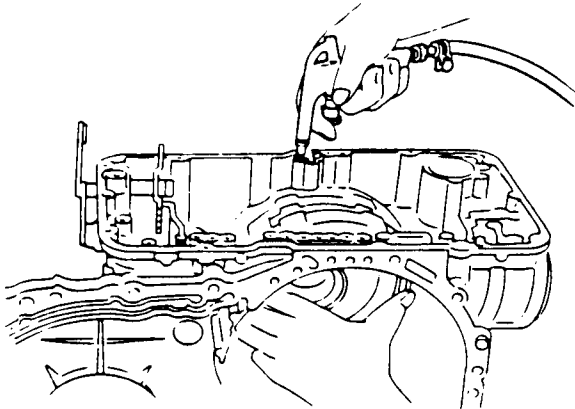

25. Remove bearing retainer assembly.

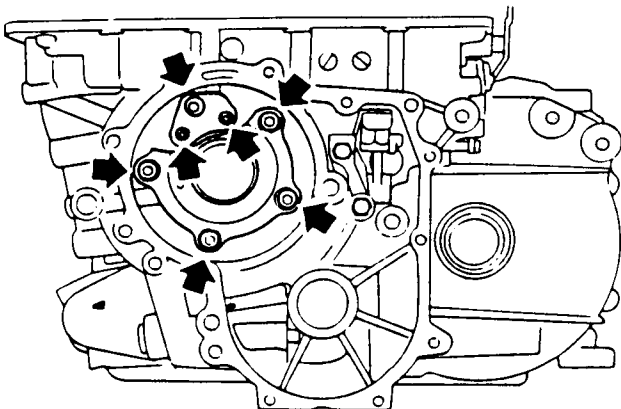

26. Remove band servo snap ring.

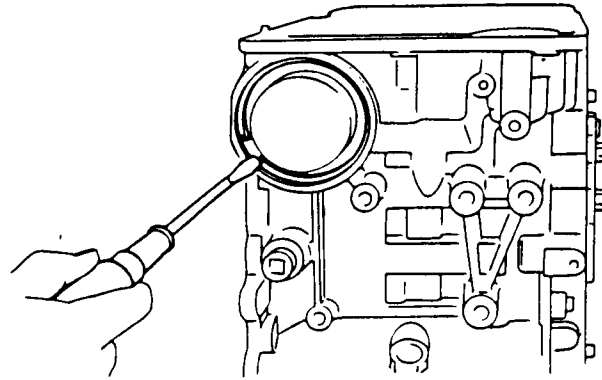

27. Remove snap ring.

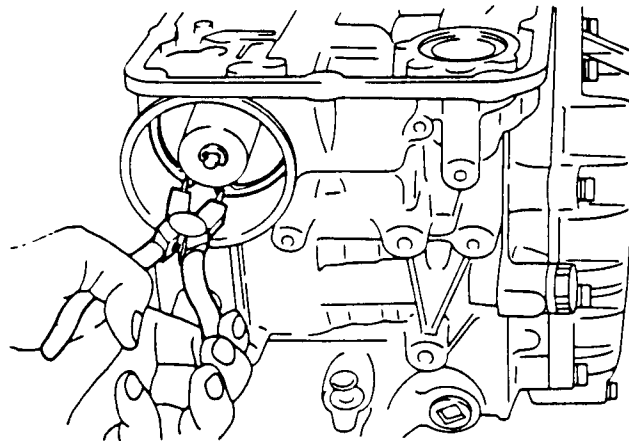

28. Remove band brake servo, retainer and return spring.

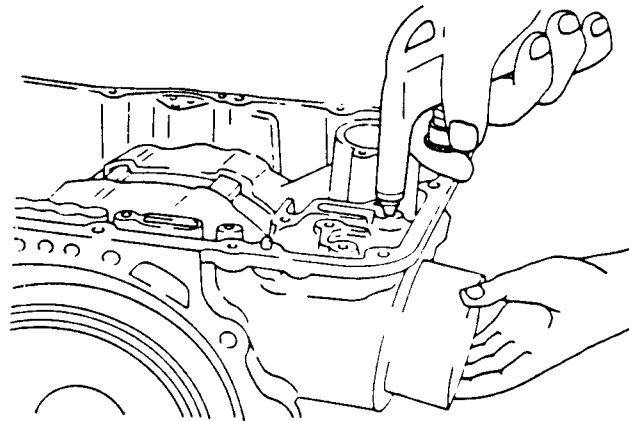

DISASSEMBLY

29. Loosen manual shaft lock nuts and remove manual plate.

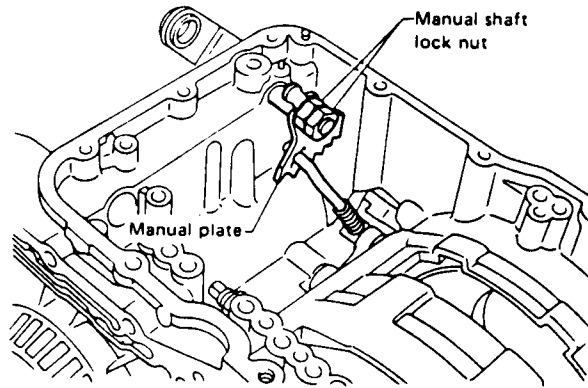

30. Pull out retaining pin, then remove manual plate and manual shaft.

Oil Pump

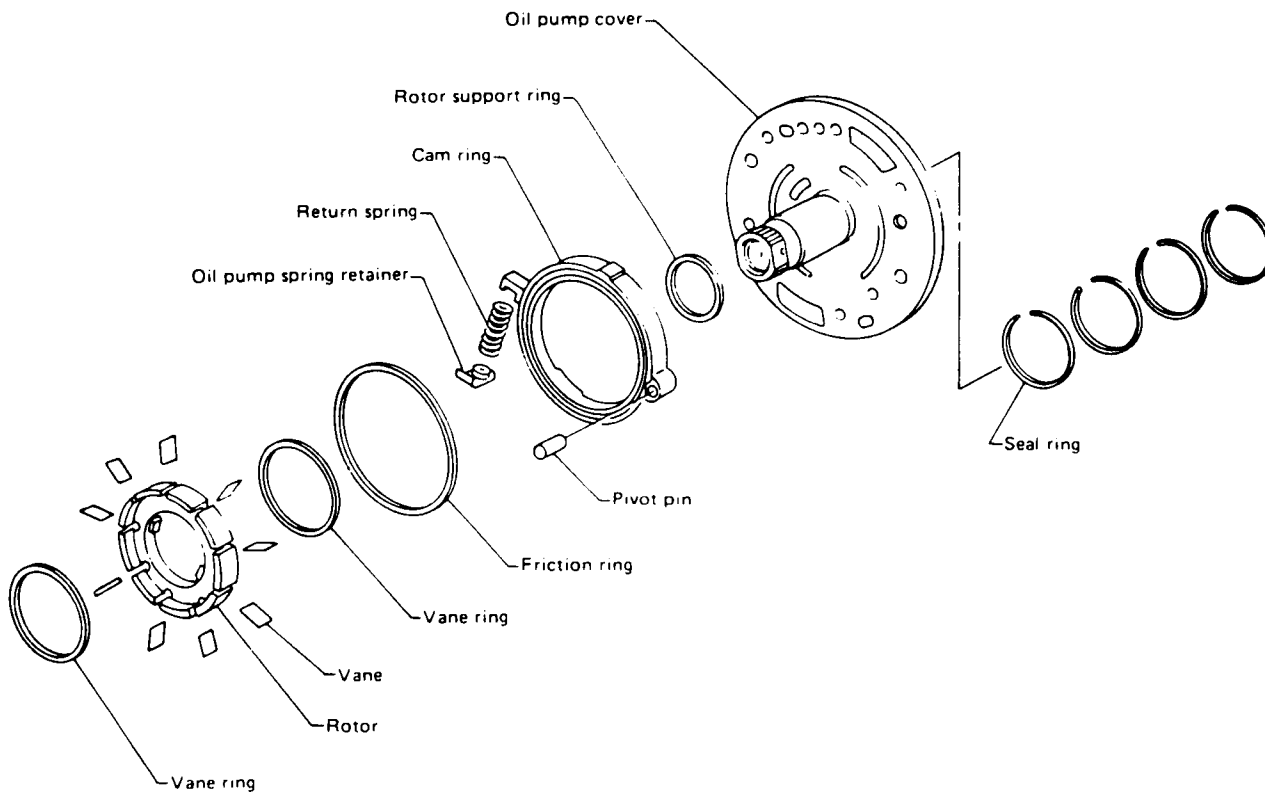

ProCarManuals.com

DISASSEMBLY

1. Remove oil pump cover.

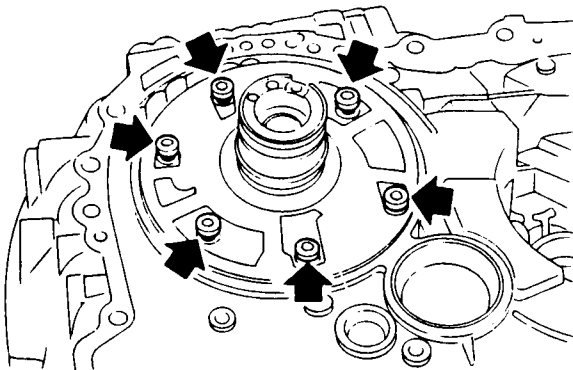

2. Remove cam ring spring while taking care not to damage converter housing.

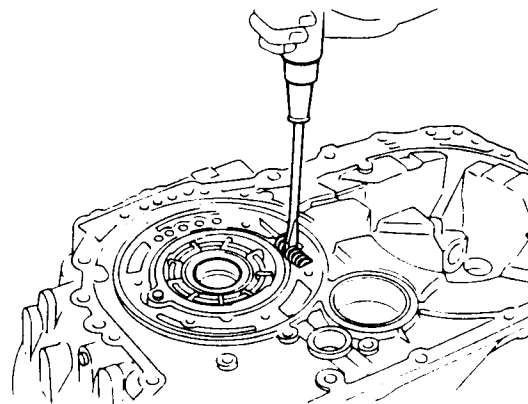

INSPECTION

1. Inspect oil pump cover, cam ring, rotor and vanes for faults and visible wear.

REPAIR FOR COMPONENT PARTS

Oil Pump (Cont'd)

- Measure clearance between clutch housing and cam ring, rotor and vanes in at least four places. The maximum measured value should be within the specified range.

Standard clearance:

0.010 - 0.024 mm (0.0004 - 0.0009 in)

Wear limit:

0.034mm (0.0013 in)

If the clearance is more than the specified wear limit, replace oil pump as an assembly.

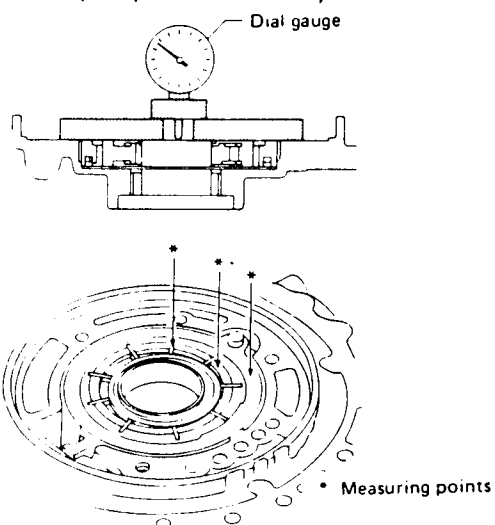

Be sure to remove friction ring and vane ring when measuring clearance. If the clearance is more than the specified wear limit, replace oil pump as an assembly.

- Measure clearance between seal ring and ring groove.

Standard clearance:

0.10 - 0.25 mm (0.0039 - 0.0098 in)

Wear limit:

0.25mm (0.0098 in.)

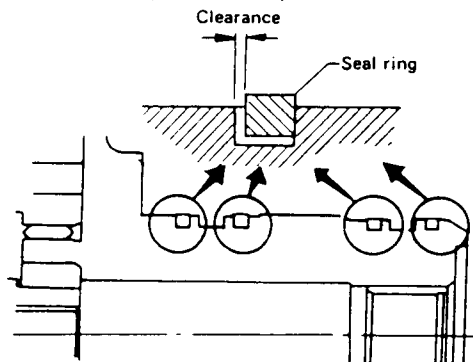

ASSEMBLY

- Install cam ring, oil pump spring retainer and cam ring spring while paying attention to the direction of the retainer.

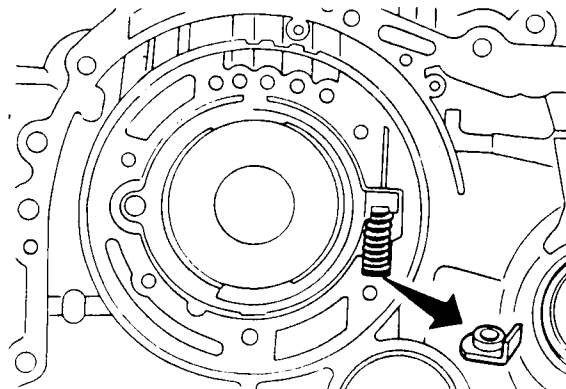

- Assemble rotor, vanes, friction ring, rotor support ring and vane rings. Pay attention to direction of rotor.

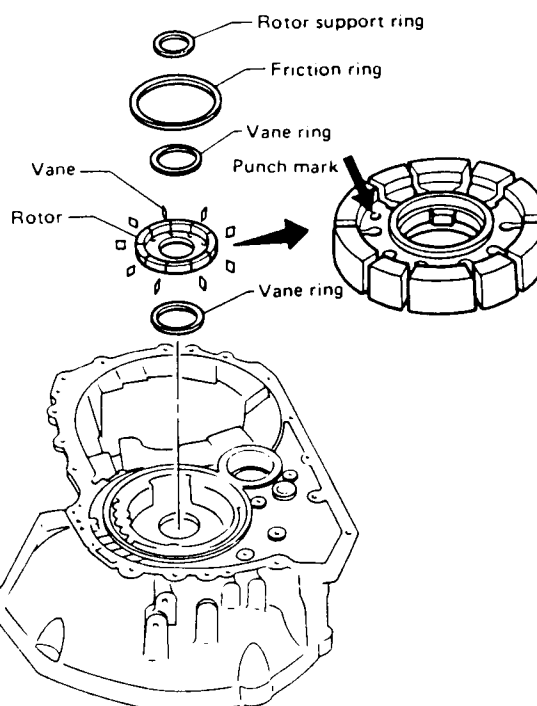

REPAIR FOR COMPONENT PARTS

Oil Pump (Cont'd)

3. Install oil pump cover.
Tighten cover evenly in a criss-cross type pattern.

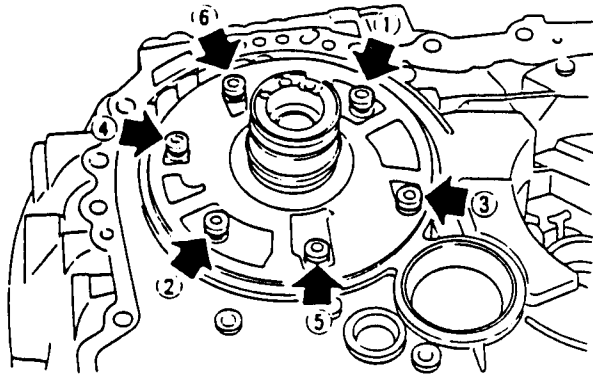

4. Rotate the pump after it has been assembled to ensure that all parts have been correctly assembled.
5. Install seal rings.

Refer to the following figure for proper locations of the two different types of seal rings.

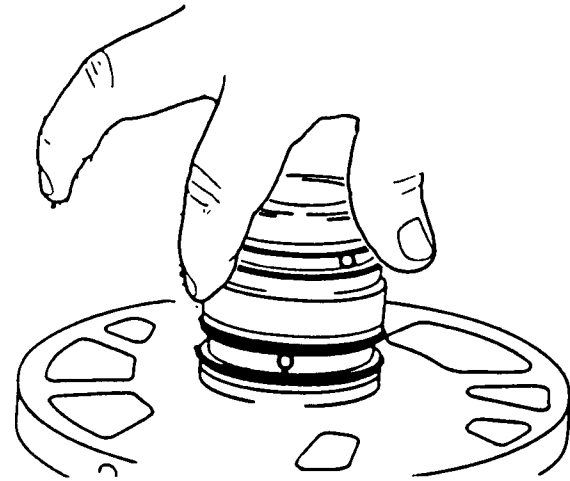
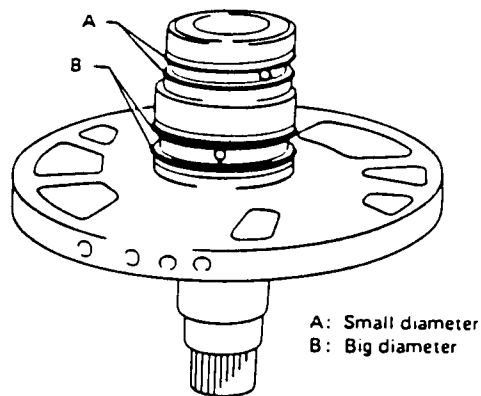

CAUTION:

These seal rings can be cut or deformed if they are improperly seated in their grooves when the drum is installed. Clean the ring grooves carefully and fill them with petroleum jelly. Then install the rings making sure they fit into the grooves as tightly as possible.

REPAIR FOR COMPONENT PARTS

Control Cylinder

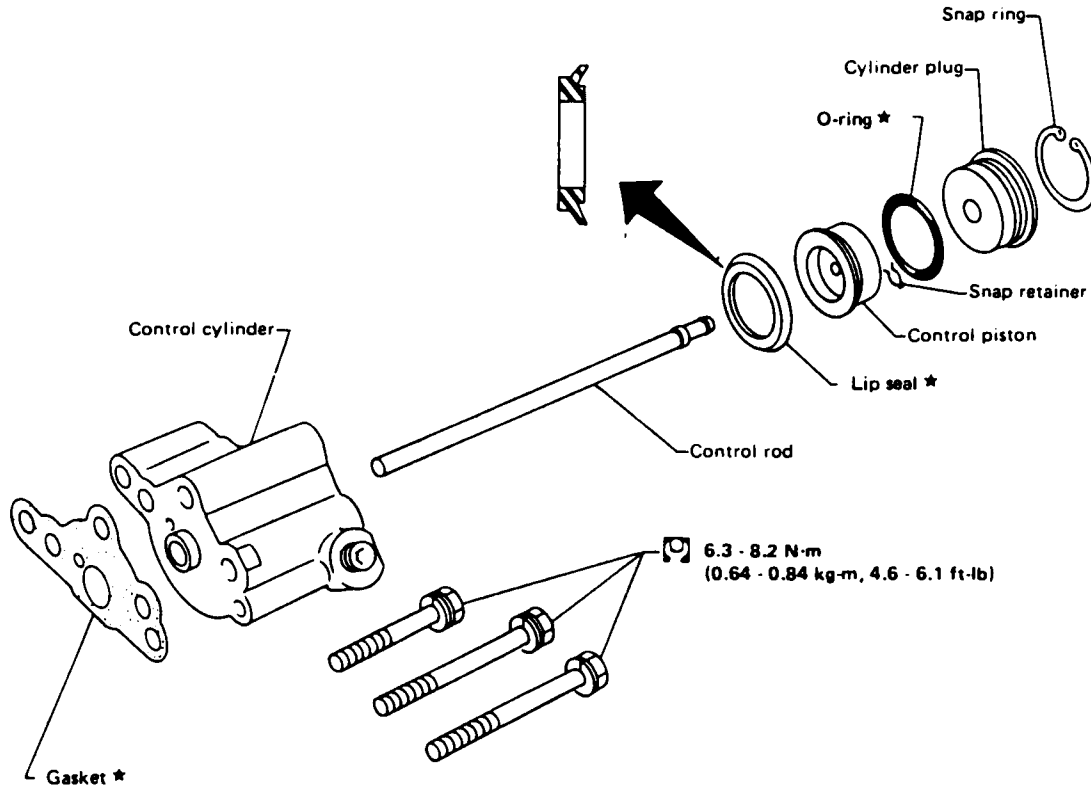

*: Always replace when disassembled.

INSPECTION AND ASSEMBLY

- Inspect control cylinder body, control piston and cylinder plug for scratches or damage. Replace if necessary.
- When assembling, pay attention to the direction of the lip seal.

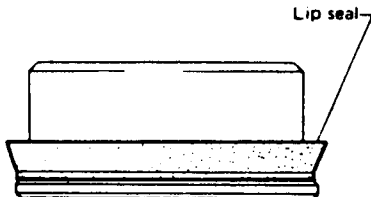

- After assembling, check the operation.

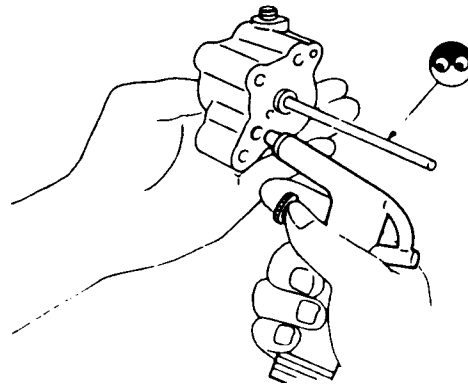

1985 - 1986 MAXIMA
VALVE BODY

ProCarManuals.com

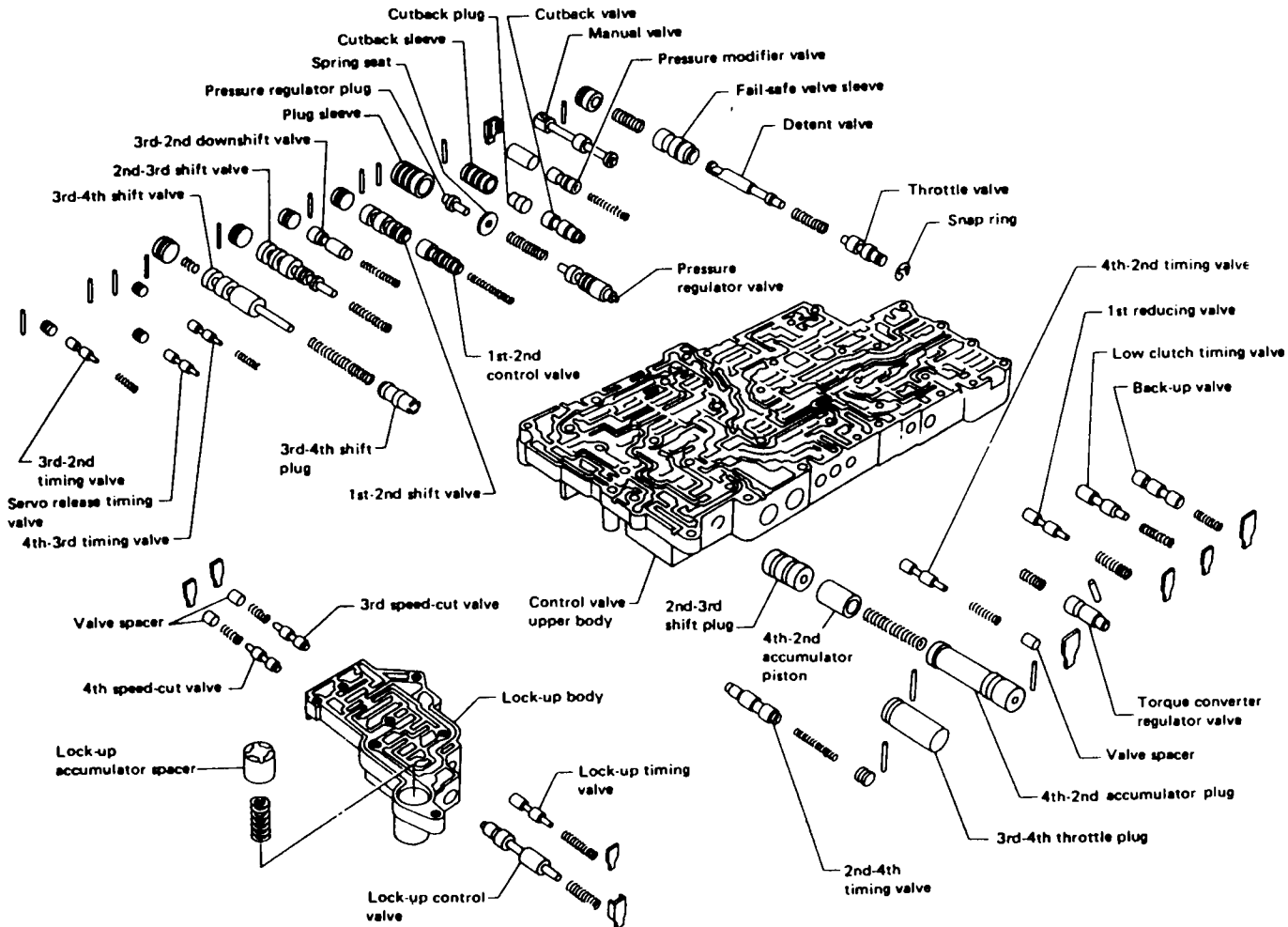

1986 STANZA WAGON VALVE BODY

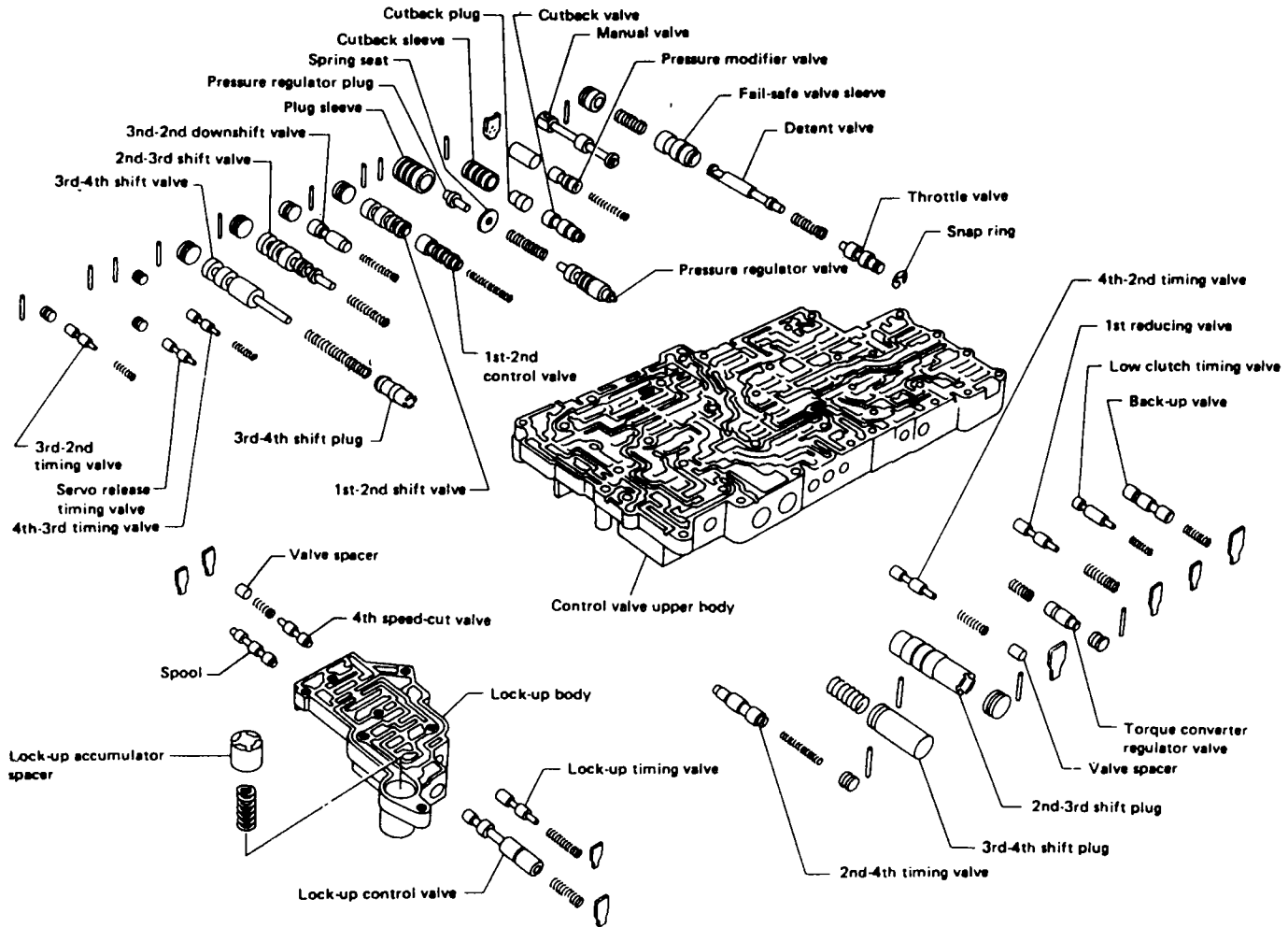

ProCarManuals.com

1987 MAXIMA VALVE BODY

ProCarManuals.com

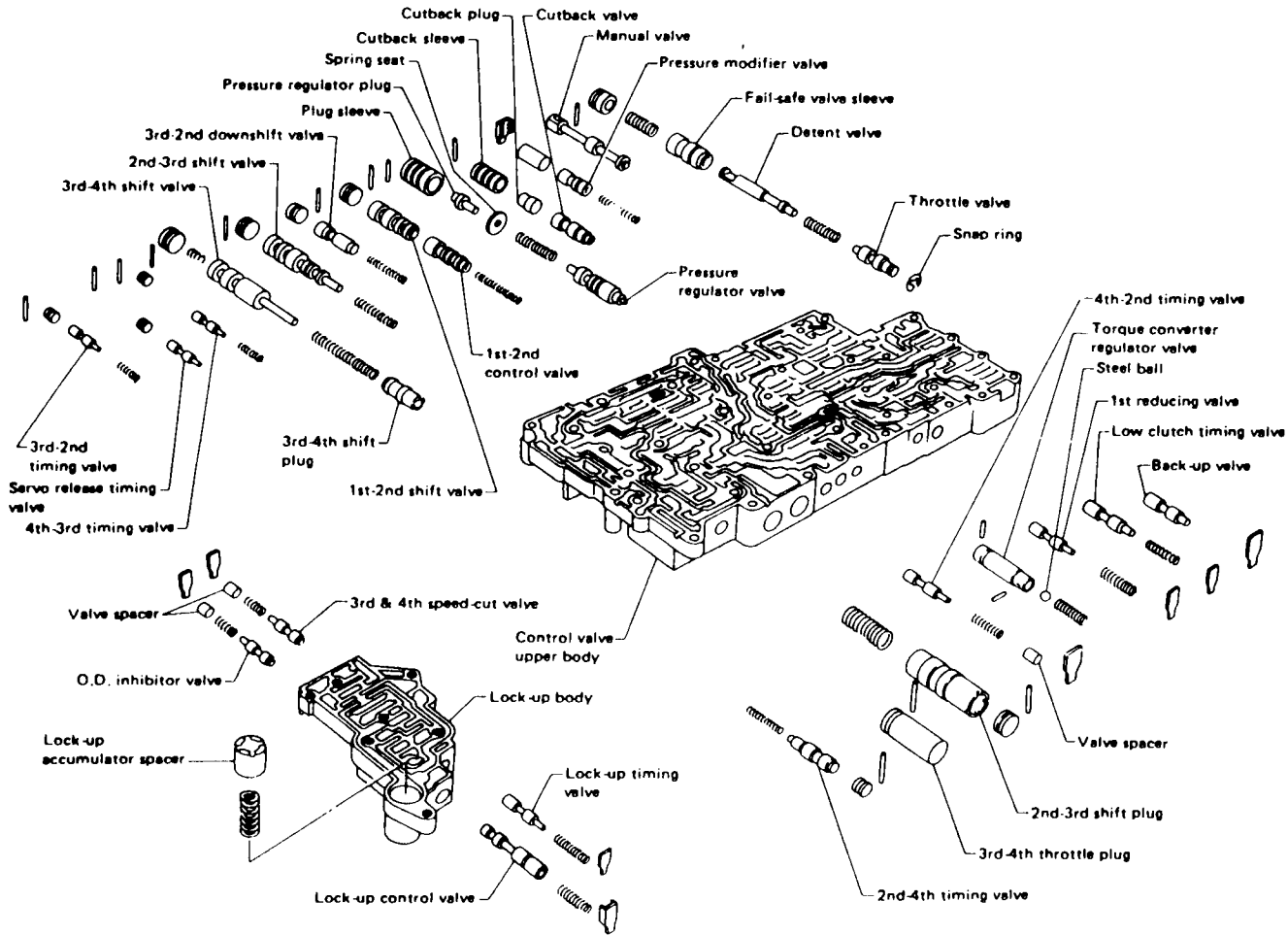

AUTOMATIC TRANSMISSION SERVICE GROUP

1988 MAXIMA VALVE BODY

ProCarManuals.com

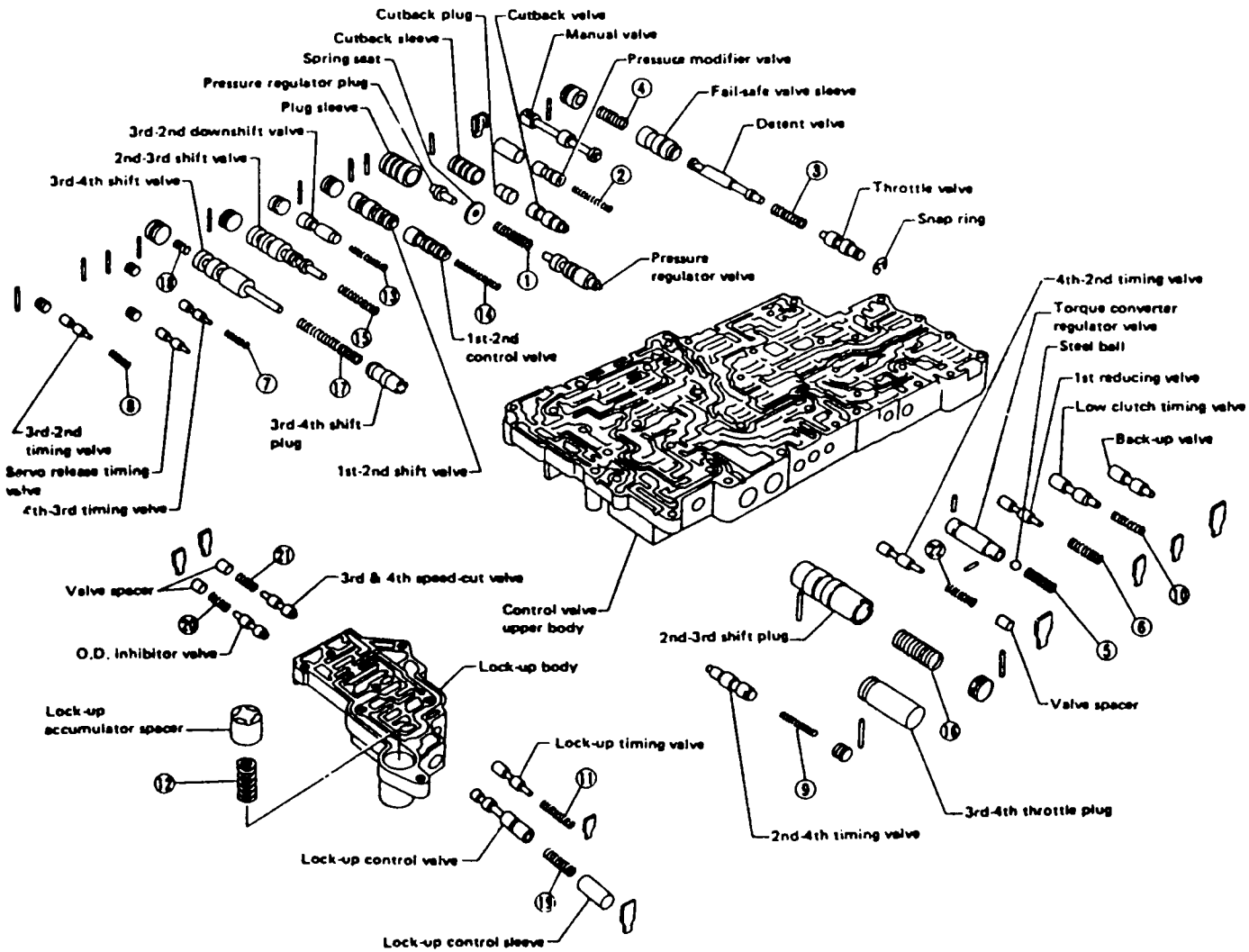

AUTOMATIC TRANSMISSION SERVICE GROUP

1988 STANZA VALVE BODY

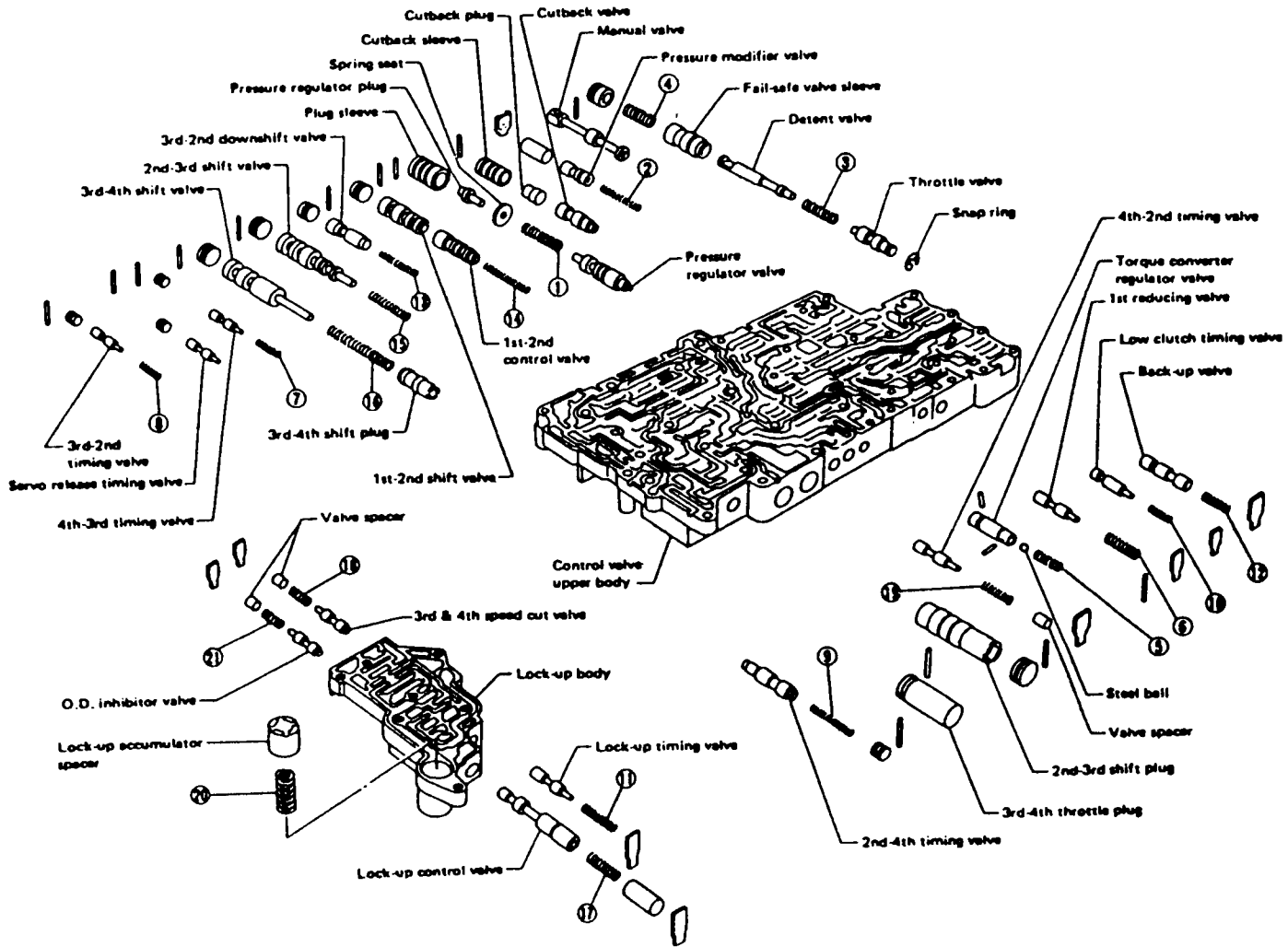

ProCarManuals.com

1989 PULSAR VALVE BODY

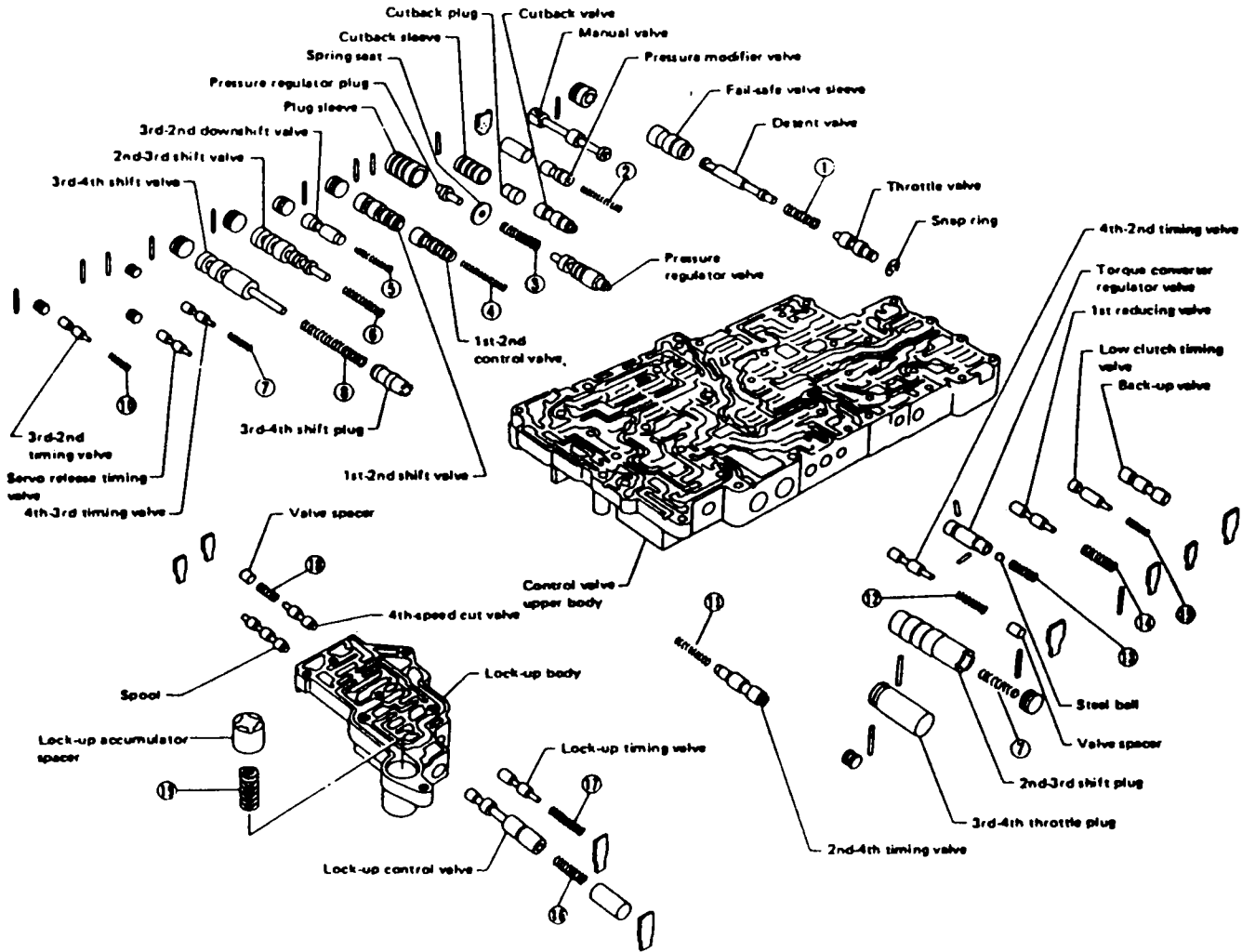

AUTOMATIC TRANSMISSION SERVICE GROUP

REPAIR FOR COMPONENT PARTS

Control Valve Body (Cont'd)

ASSEMBLY

1. Reinstall steel balls in valve body.

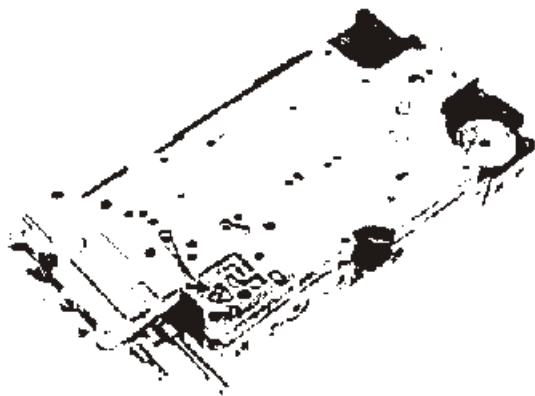
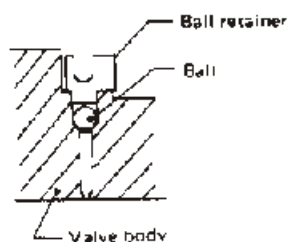
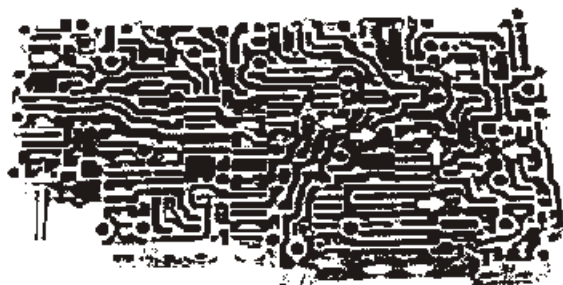

2. Assemble separator plate and lower valve body on upper valve body and lock-up body.
 - Dip gasket in A.T.F. before installation.
 - Pay attention to the position of gaskets.

Upper body separator plate



Lower body separator plate

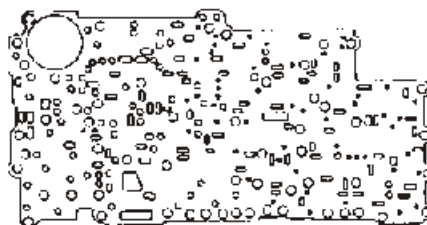

Lock-up body separator plate

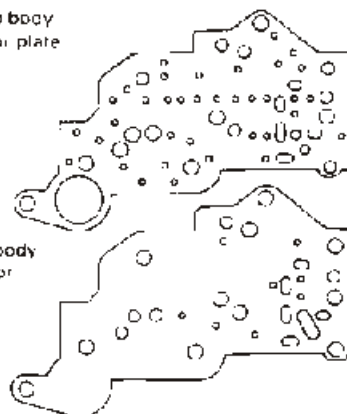

Upper body separator plate

- When installing these bolts, first be sure to install the two reamer bolts to their original positions.
- Pay attention to the position of harness clamps when installing control valve bolts.

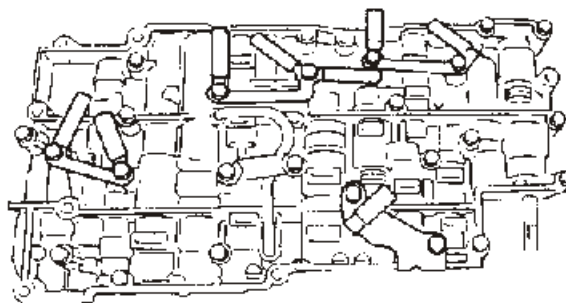

REPAIR FOR COMPONENT PARTS

High Clutch

In regard to the number of clutch sheets (drive plate and driven plate), refer to S.O.S.

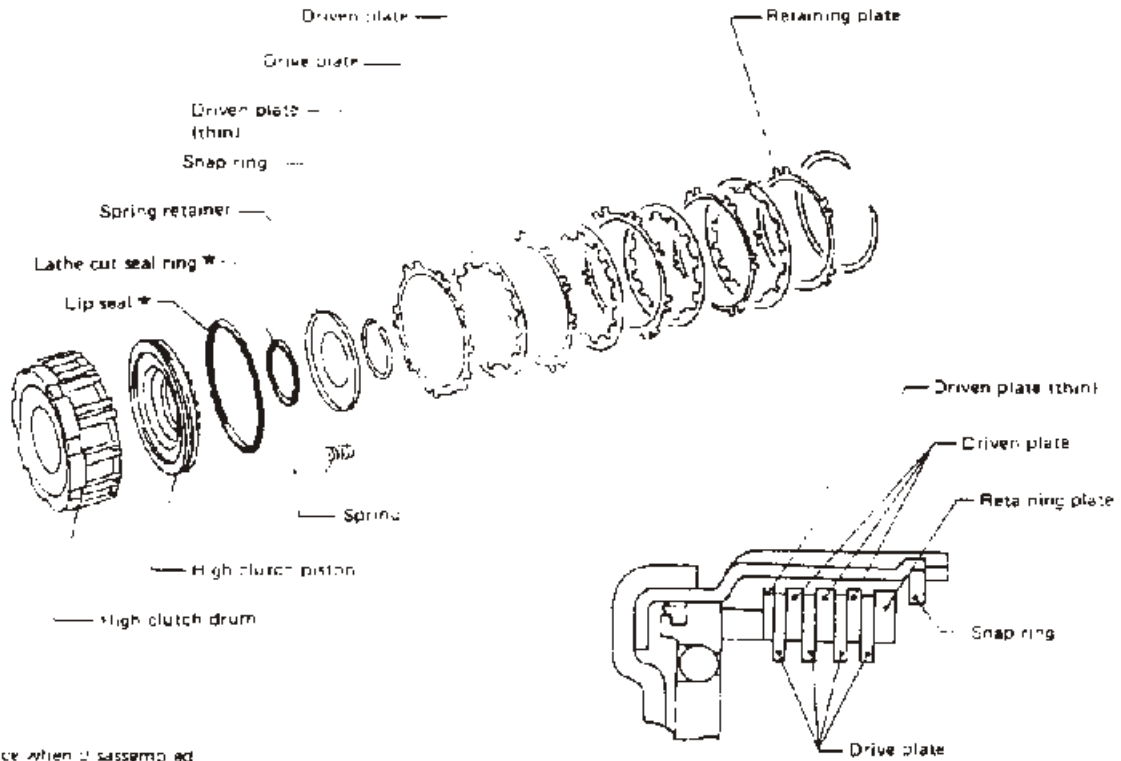

* Always replace when disassembled.

DISASSEMBLY

- Compress clutch springs and remove snap ring from spring retainer.

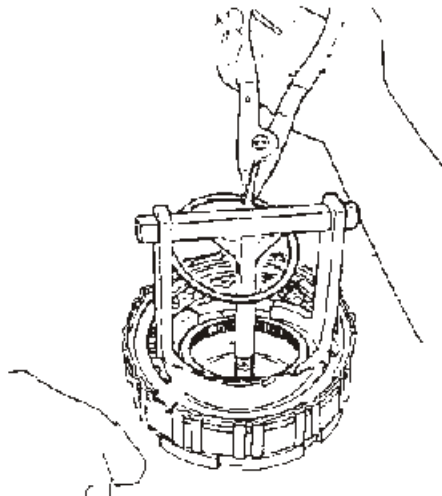

- Place clutch drum onto oil pump, and withdraw clutch piston using compressed air.

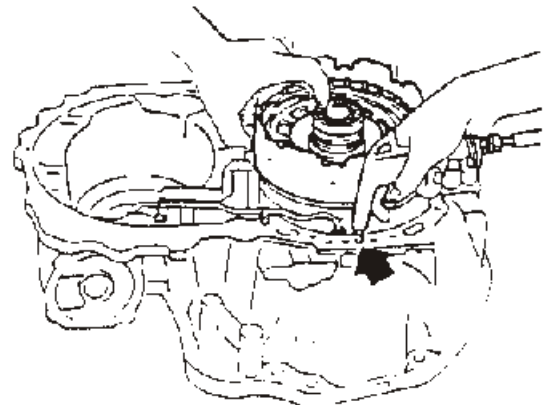

High Clutch (Cont'd)

INSPECTION AND ASSEMBLY

1. Check clutch drive plate facing for wear or damage. Drive plate thickness must not be less than 1.4 mm (0.055 in).

Standard drive plate thickness:

1.6 mm (0.063 in)

2. Check for wear on snap ring, weak or broken coil springs, and warped spring retainer.
3. Lubricate clutch drum bushing, and install inner seal and piston seal as illustrated. Be careful not to stretch seals during installation.
 - Never assemble clutch dry; always lubricate its components thoroughly.
 - Always install piston seal in direction show in figure below.

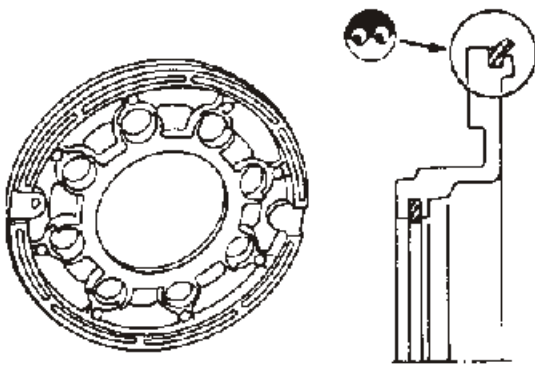

4. Assemble piston, being careful not to allow seal to kink or become damaged during installation.

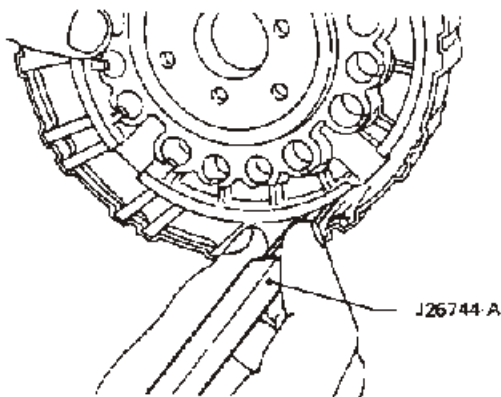

Use a suitable tool, which does not damage lip seal, to make sure the lip seal goes into place.

5. After installing, turn piston by hand to ensure that there is no binding.

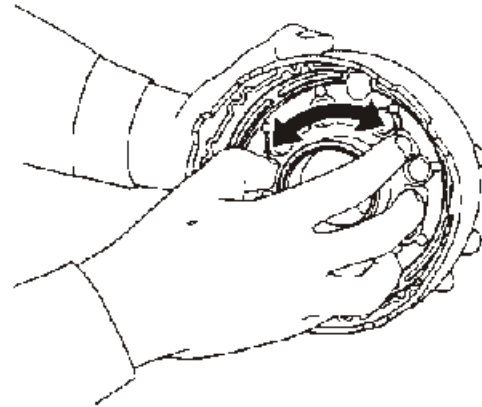

5. Install clutch springs.
Pay attention to the position of clutch springs.

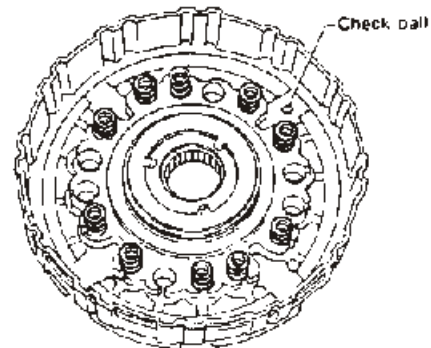

High Clutch (Cont'd)

6. Reinstall snap ring. Be sure snap ring is properly seated.

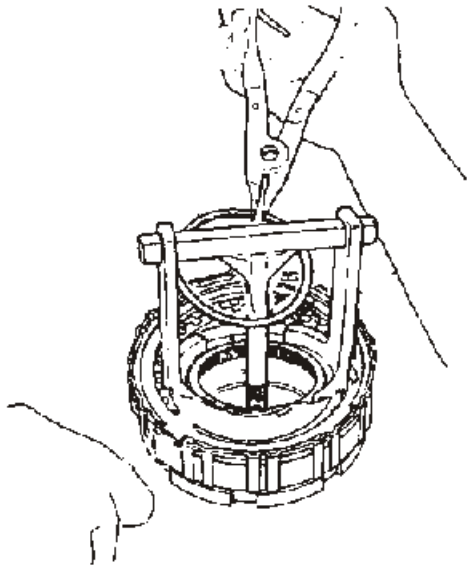

7. Install driven plates, drive plates, and secure with snap ring.

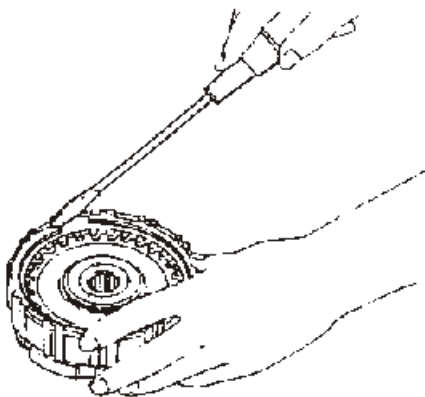

8. Measure clearance between retainer plate and snap ring.

Always measure the existing minimum clearance, since snap ring is a wave type.

Specified clearance:

Standard

1.8 - 2.2 mm (0.071 - 0.087 in)

Allowable limit

3.0 mm (0.118 in)

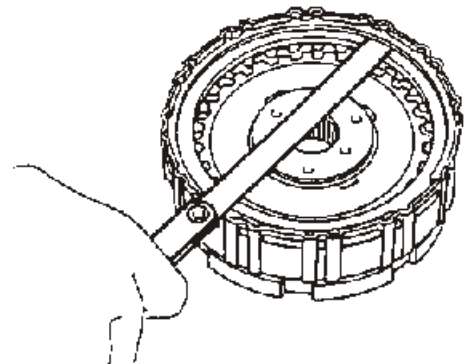

Available retaining plate

Thickness mm (in)	Part number
3.6 (0.142)	31567-21X00
3.8 (0.150)	31567-21X01
4.0 (0.157)	31567-21X02
4.2 (0.165)	31567-21X03
4.4 (0.173)	31567-21X04
4.6 (0.181)	31567-21X05
4.8 (0.189)	31567-21X06
5.0 (0.197)	31567-21X10

9. Check high clutch operation using compressed air.

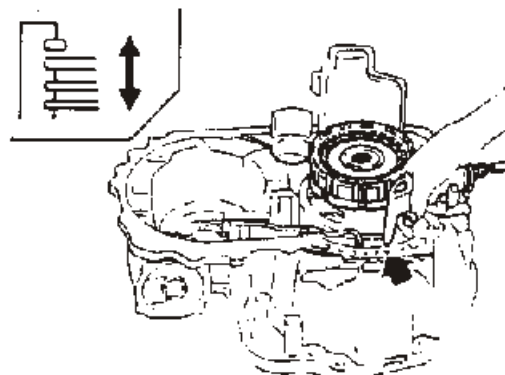

REPAIR FOR COMPONENT PARTS

Low Clutch

In regard to the number of clutch sheets (drive plate and driven plate), refer to S.D.S.

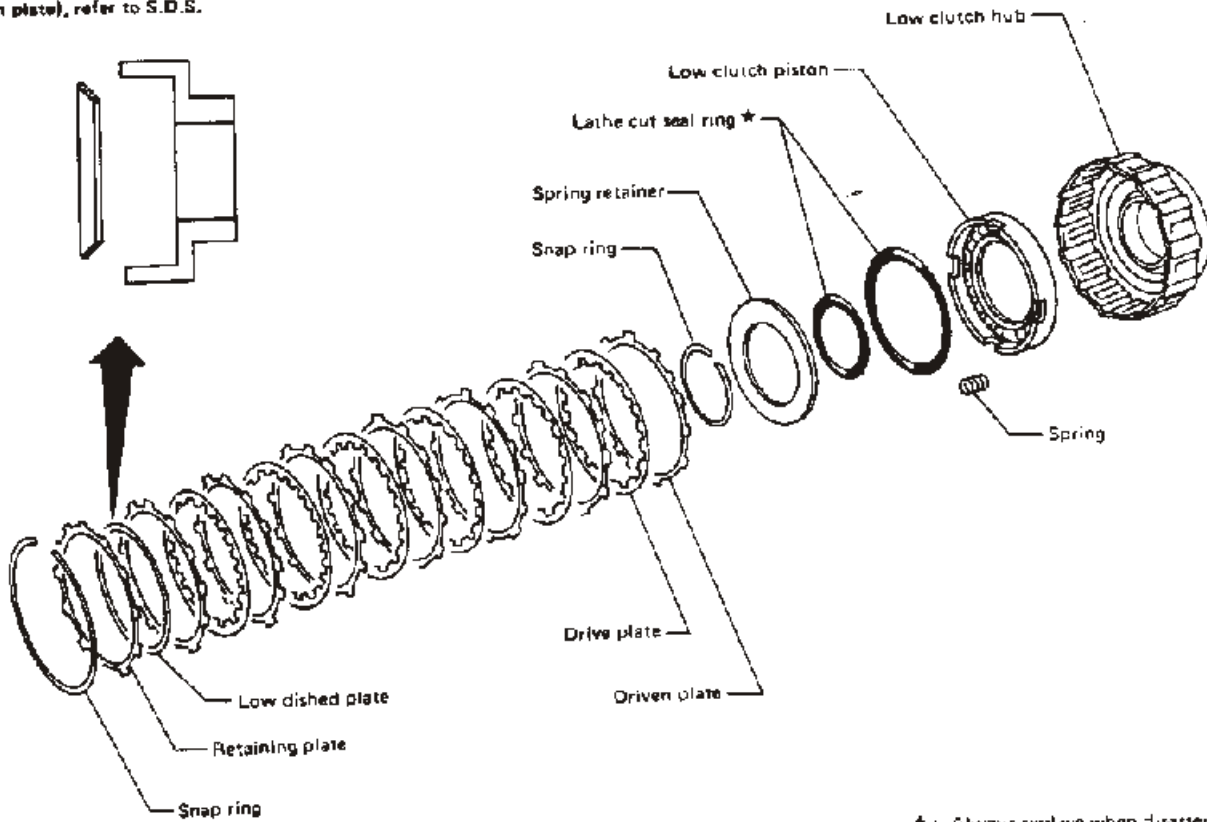

* : Always replace when disassembled.

REPAIR FOR COMPONENT PARTS

Low Clutch (Cont'd)

- Use a suitable tool to remove the clutch spring snap ring.

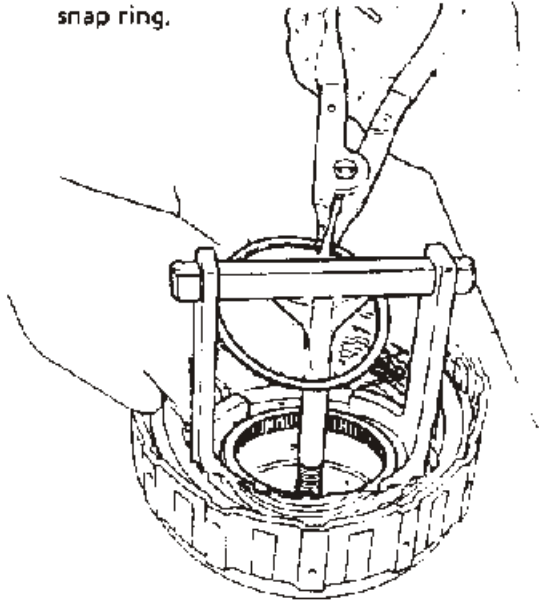

Service procedures for low clutch are essentially the same as those for high clutch, with the following exception

Drive plate thickness:

Standard

2.0 mm (0.079 in)

Allowable limit

1.8 mm (0.071 in)

Specified clearance between retainer plate and snap ring:

Standard

0.5 - 0.8 mm (0.020 - 0.031 in)

Allowable limit

2.0 mm (0.079 in)

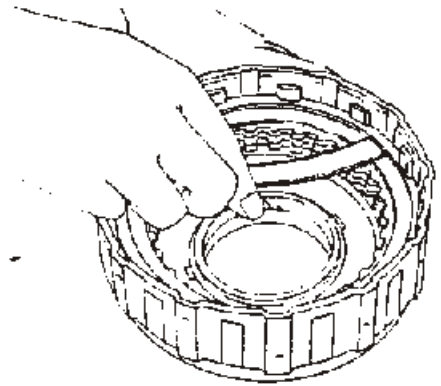

Available retaining plate

Thickness mm (in)	Part number
3.2 (0.126)	31597-21X10
3.4 (0.134)	31597-21X11
3.6 (0.142)	31597-21X12
3.8 (0.150)	31597-21X13
4.0 (0.157)	31597-21X14
4.2 (0.165)	31597-21X15

After assembly, check the operation of the clutch.

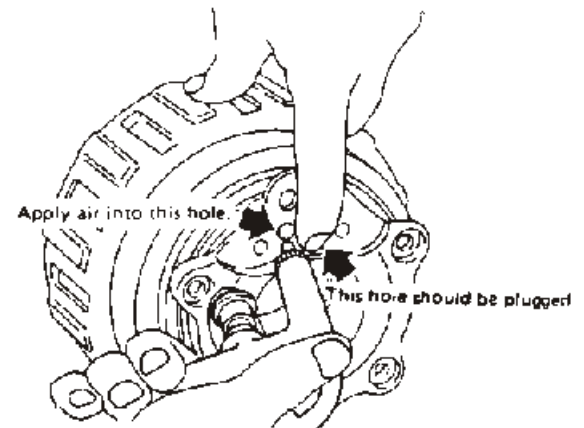



Technical Service Information

REPAIR FOR COMPONENT PARTS

Reverse Clutch

In regard to the number of clutch sheets (drive plate and driven plate), refer to S.D.S.

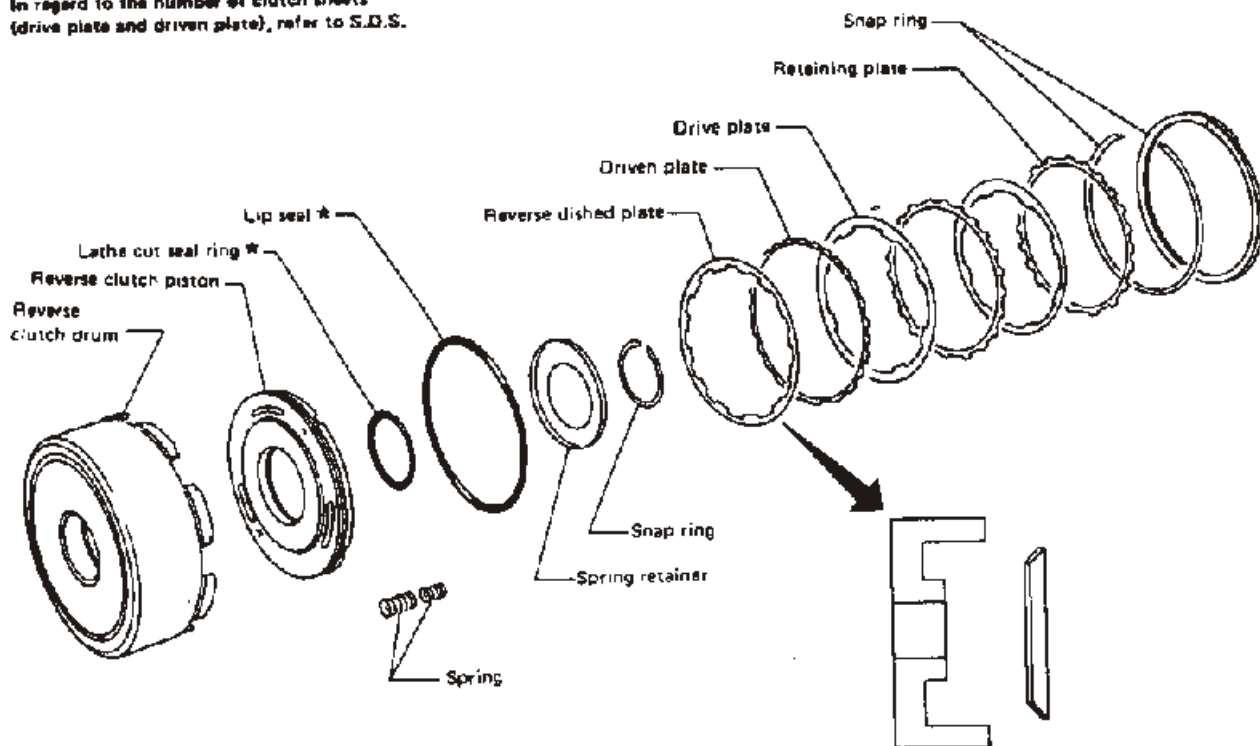

★ Always replace when disassembled.

Service procedures for reverse clutch are essentially the same as those for high clutch, with the following exception.

- Use the procedure shown below to remove the reverse clutch piston.

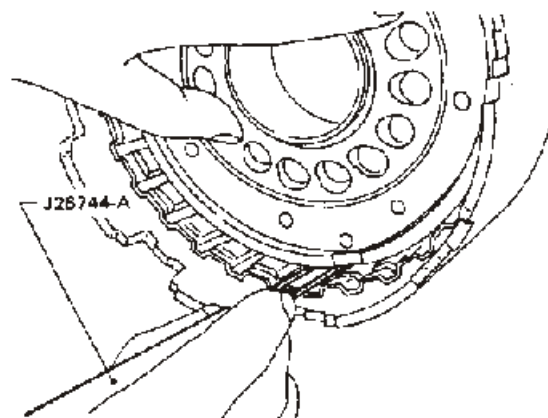
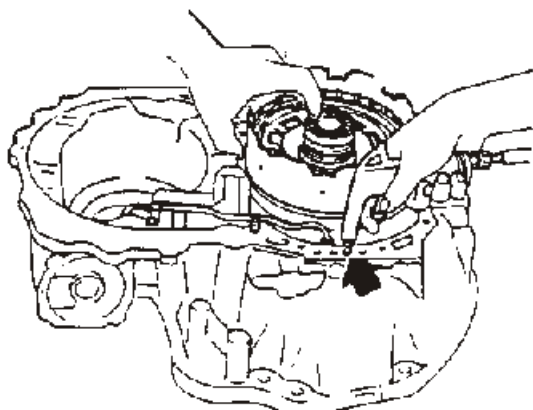

Use suitable tool, which does not damage lip seal, to make sure lip seal goes into place.

AUTOMATIC TRANSMISSION SERVICE GROUP

REPAIR FOR COMPONENT PARTS

Reverse Clutch (Cont'd)

Drive plate thickness:

Standard

2.0 mm (0.079 in)

1.8 mm (0.071 in)

Specified clearance between retainer plate
and snap ring:

Standard

0.5 - 0.8 mm (0.020 - 0.031 in)

Allowable limit

1.2 mm (0.047 in)

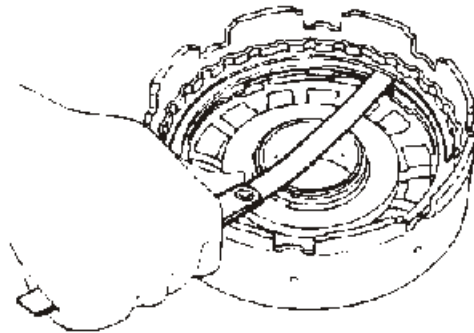

Thickness mm (in)	Part number
4.6 (0.181)	31537-21X10
4.8 (0.189)	31537-21X11
5.0 (0.197)	31537-21X12
5.2 (0.205)	31537-21X13
5.4 (0.213)	31537-21X14

After assembly, check the operation of the clutch.

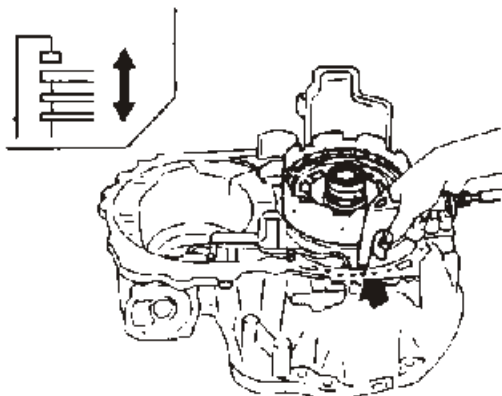

AUTOMATIC TRANSMISSION SERVICE GROUP

REPAIR FOR COMPONENT PARTS

Low & Reverse Brake

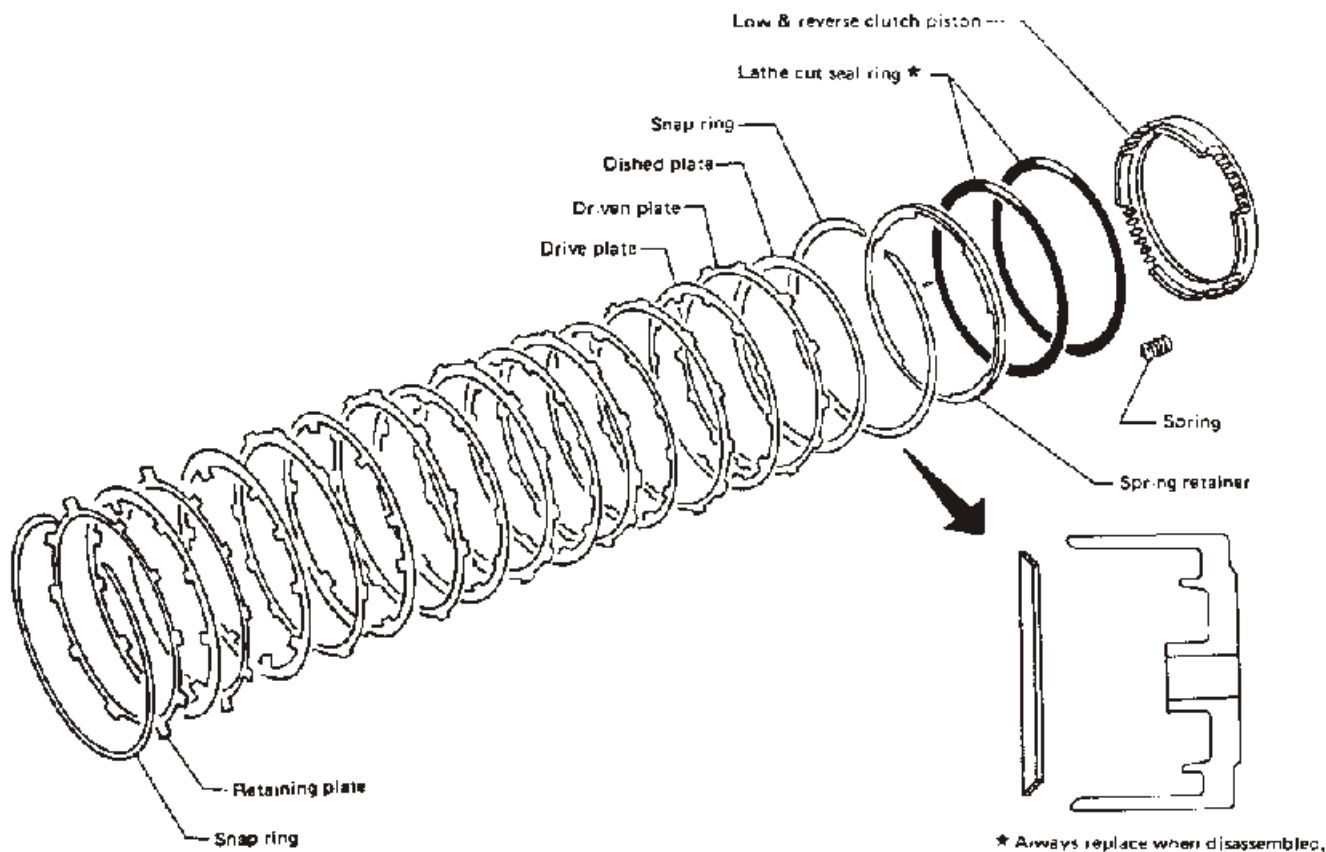

INSPECTION

- Examine low and reverse brake for damaged clutch drive plate facing and worn snap ring.
- Check drive plate facing for wear or damage; if necessary, replace.

Drive plate thickness:

Standard

2.0 mm (0.079 in)

Allowable limit

1.8 mm (0.071 in)

Specified clearance between retainer plate and snap ring:

Standard

2.2 - 2.6 mm (0.087 - 0.102 in)

Allowable limit

4.0 mm (0.157 in)

Available retainer plate

Thickness mm (in)	Part number
3.4 (0.134)	31667-21X00
3.6 (0.142)	31667-21X01
3.8 (0.150)	31667-21X02
4.0 (0.157)	31667-21X03
4.2 (0.165)	31667-21X04
4.4 (0.173)	31667-21X05
4.6 (0.181)	31667-21X06
4.8 (0.189)	31667-21X07
5.0 (0.197)	31667-21X08

REPAIR FOR COMPONENT PARTS

Brake Band and Band Servo

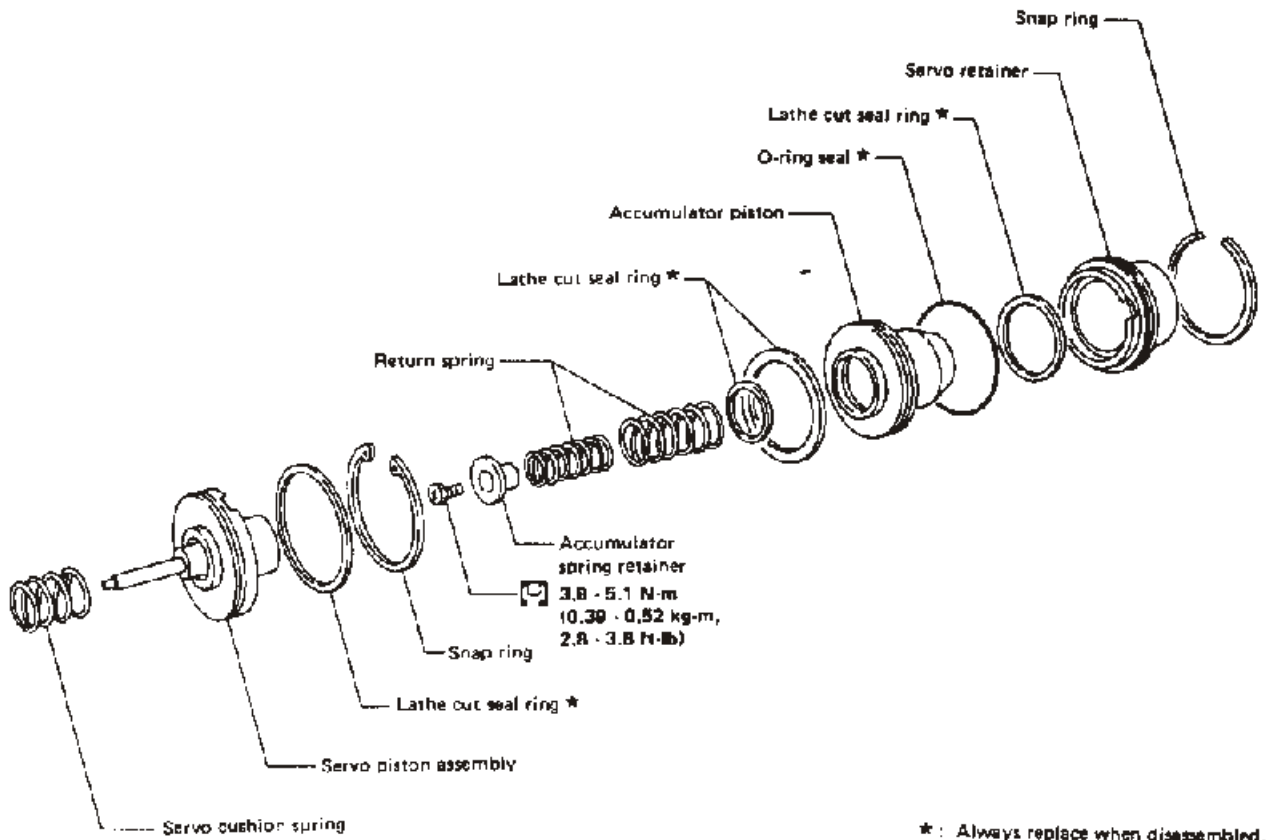

INSPECTION

- Inspect band friction material for wear. If cracked, chipped or burnt spots are apparent, replace the band.

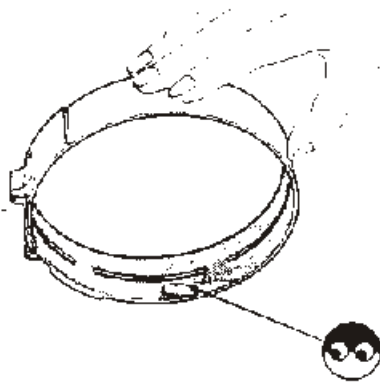

- Check band servo components for wear and scoring.

REPAIR FOR COMPONENT PARTS

Governor

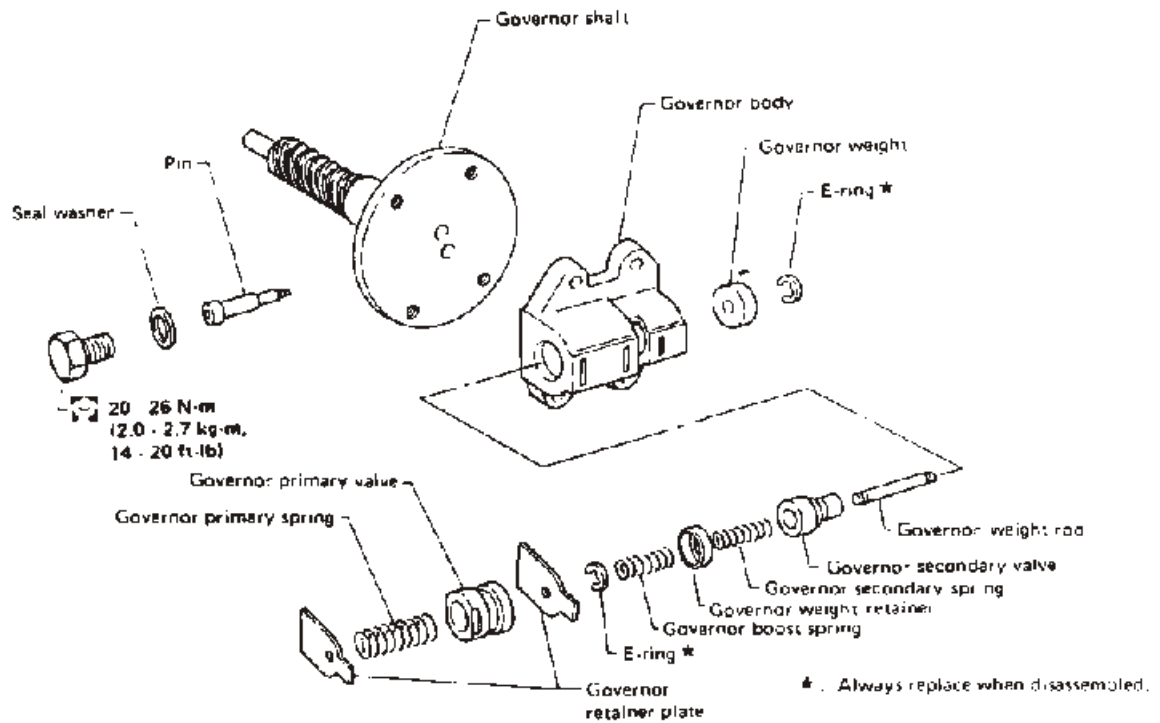

INSPECTION

- Check governor valves and valve body for indication of burning or scratches.
- Check valve springs for damage.
Measure free length of valve springs.

Valve spring	Free length mm (in)
Primary governor	31.7 (1.248)
Secondary governor	25.1 (0.988)
Governor boost	28.2 (1.110)

If any abnormalities are found, replace governor body, valves and springs as an assembly.

REPAIR FOR COMPONENT PARTS

Planetary Carrier

INSPECTION

- Check clearance between pinion washer and planetary carrier with a feeler gauge.

Standard clearance:

0.15 - 0.70 mm (0.0059 - 0.0276 in)

Replace if the clearance exceeds 0.80 mm (0.0315 in).

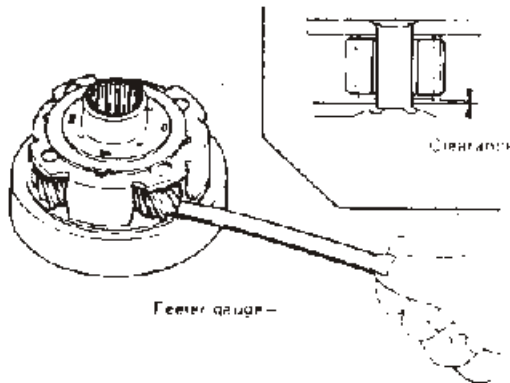

- Check planetary gear sets and bearings for damaged or worn gears.

Bearing Retainer and Output Shaft

INSPECTION

Measure clearance between seal ring and ring groove.

Standard clearance:

0.10 - 0.25 mm (0.0039 - 0.0098 in)

Wear limit:

0.25 mm (0.0098 in)

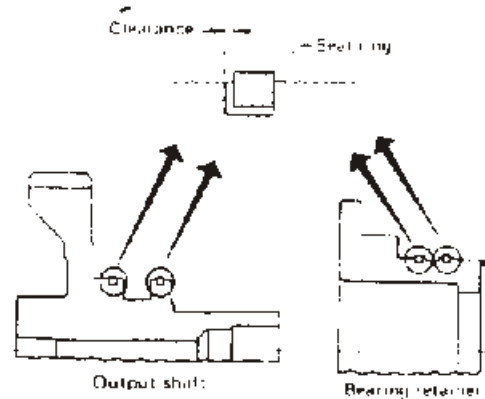

REPAIR FOR COMPONENT PARTS

Converter Housing and Transmission Case

BEARING OUTER RACE

- Reduction pinion gear front bearing outer race.

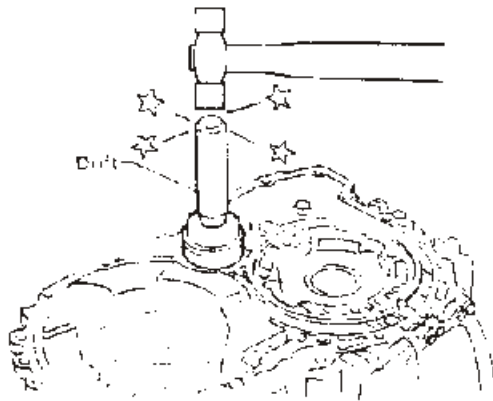
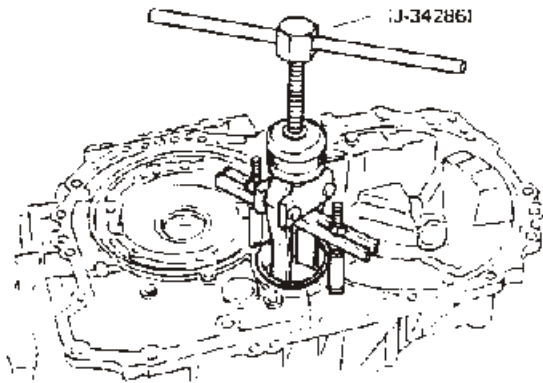

- Diff. side bearing outer race.

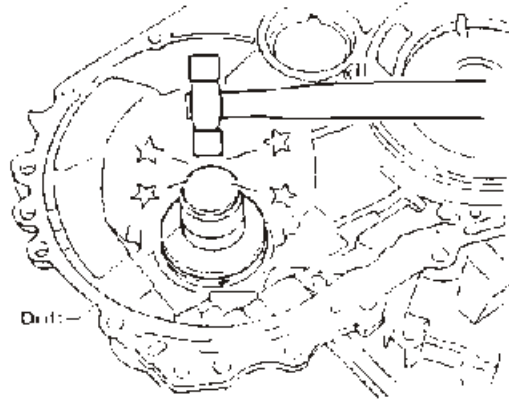
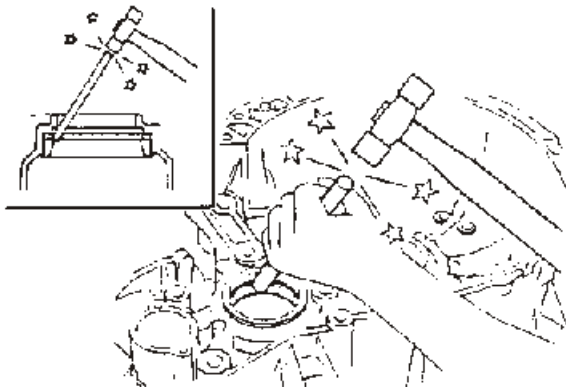

OIL SEAL

- Torque converter oil seal.

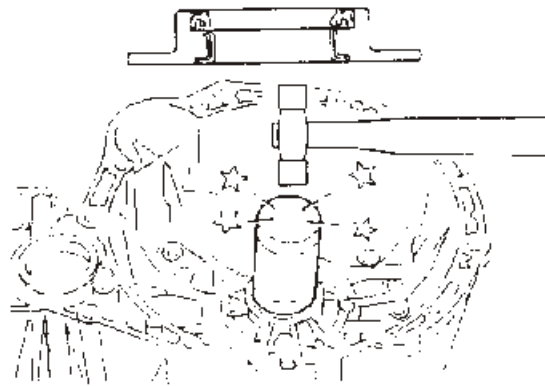

- Diff. side oil seal.

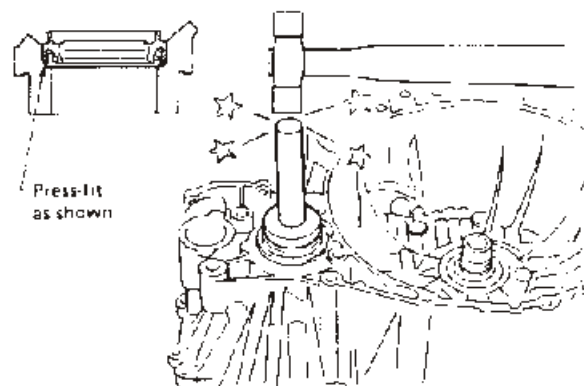

REPAIR FOR COMPONENT PARTS

Final Drive

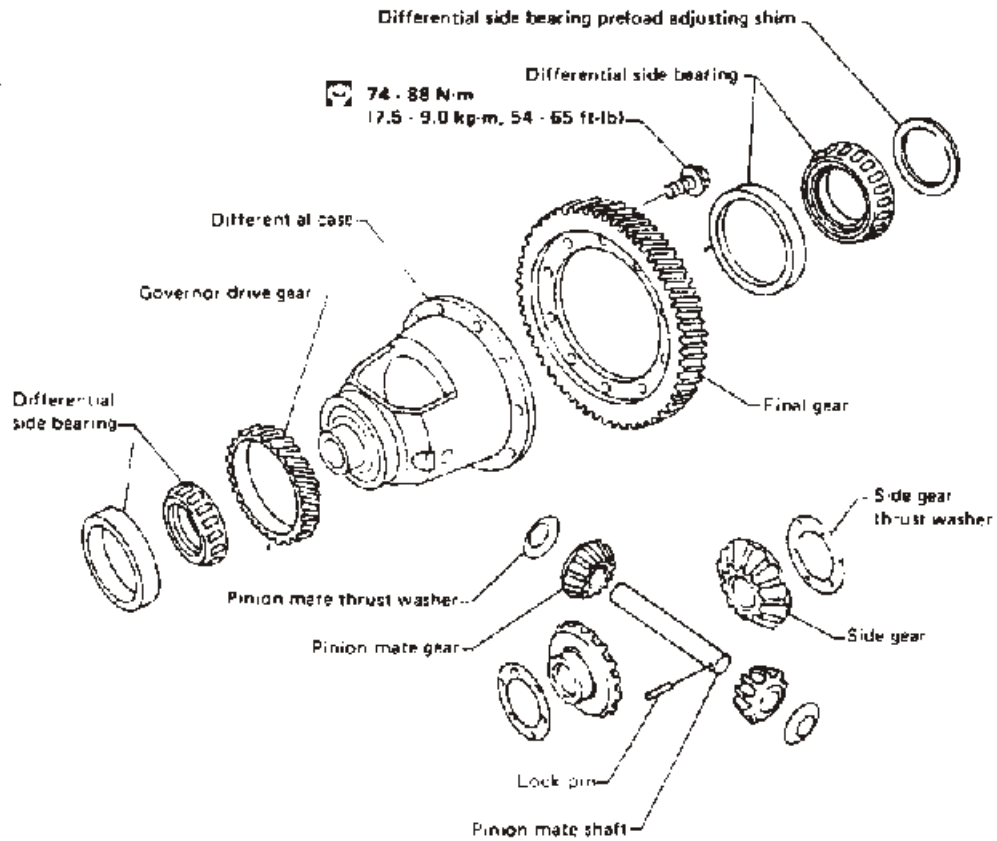

DISASSEMBLY

1. Remove final gear.

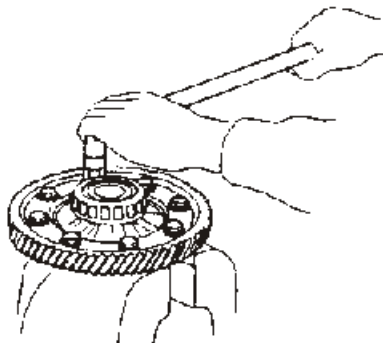

2. Drive out pinion mate shaft lock pin and draw out pinion mate shaft.

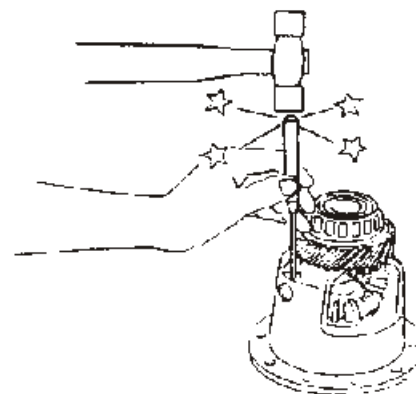

REPAIR FOR COMPONENT PARTS

Final Drive (Cont'd)

3. Remove governor drive gear.

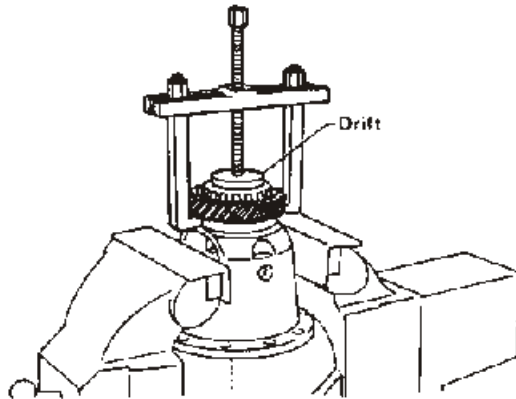

4. Drive out diff. side bearing outer race and inner race.

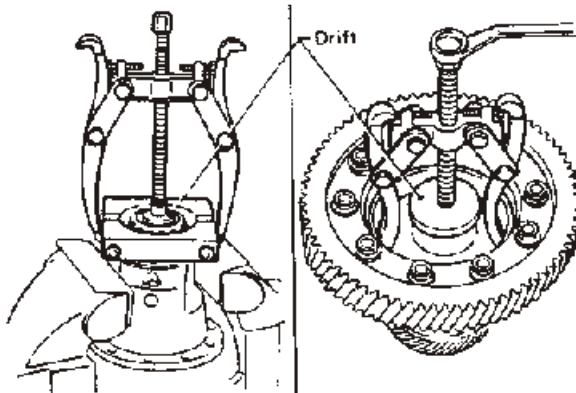

INSPECTION

1. Check mating surface of differential case, side gears and pinion mate gears. Replace as required.

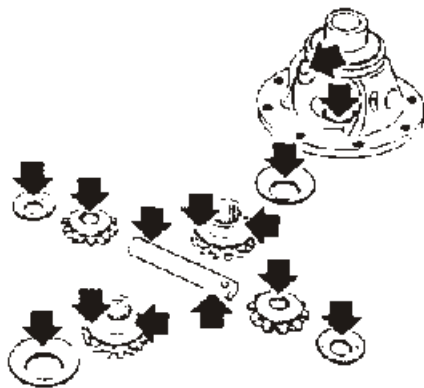

2. Check clearance between side gear and diff. case with washer following the procedure below.

- (1) Set Tool and dial gauge on side gear.

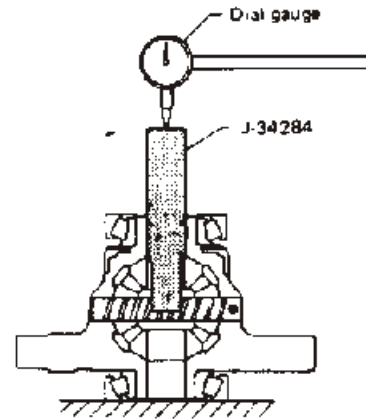

- (2) Move side gear up and down to measure dial gauge deflection. Always measure gauge deflection on both side gears.

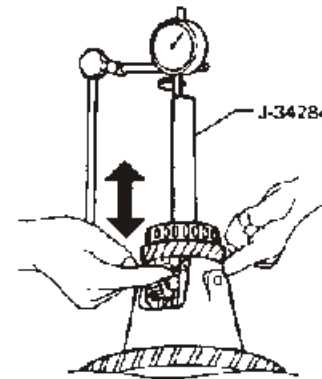

Clearance between side gear and diff. case with washer:

0 - 0.2 mm (0 - 0.008 in)

- (3) If clearance exceeds the specified value, check for wear and replace necessary parts.
3. Check tapered roller bearings for wear, scratches, pitting or flaking.

REPAIR FOR COMPONENT PARTS

Final Drive (Cont'd)

ASSEMBLY

1. Install the side gear and thrust washer in the differential case.
2. Install the pinion mate gear and thrust washer in the differential case while rotating them.



3. Insert pinion mate shaft.

When inserting, be careful not to damage pinion mate washers.

4. Measure clearance between side gear and pinion mate gear, referring to "Inspection". If necessary, adjust.

Side gear to pinion mate clearance:

0 - 0.2 mm (0 - 0.008 in)

Side gear thrust washer:

Refer to S.D.S., page AT-84.

5. Install pinion mate shaft lock pin using a punch.

Make sure that lock pin is flush with case.

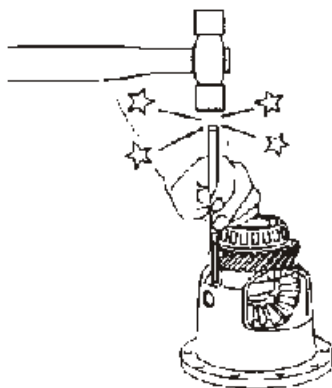

6. Install governor drive gear.

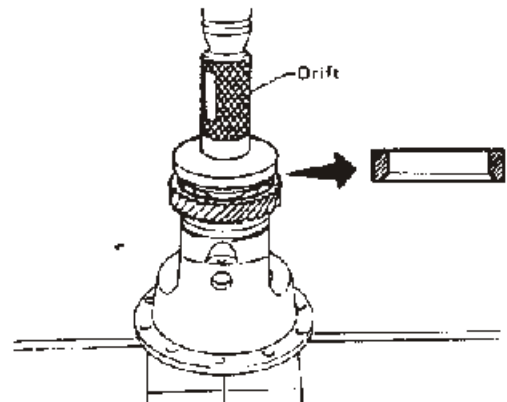

7. Press on diff. side bearing inner race and outer race.

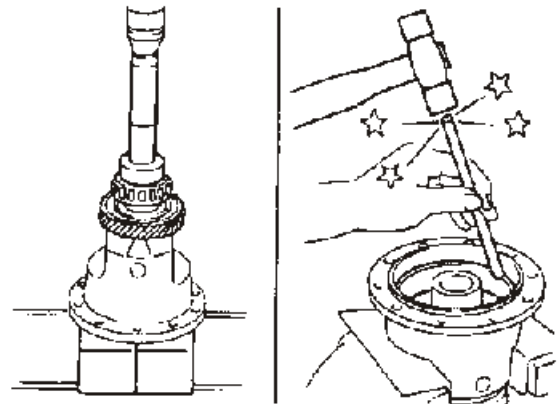

8. Install final gear.

AUTOMATIC TRANSMISSION SERVICE GROUP

When installing/assembling needle bearing and bearing race, use the following illustration as a guide to installation procedures and locations.

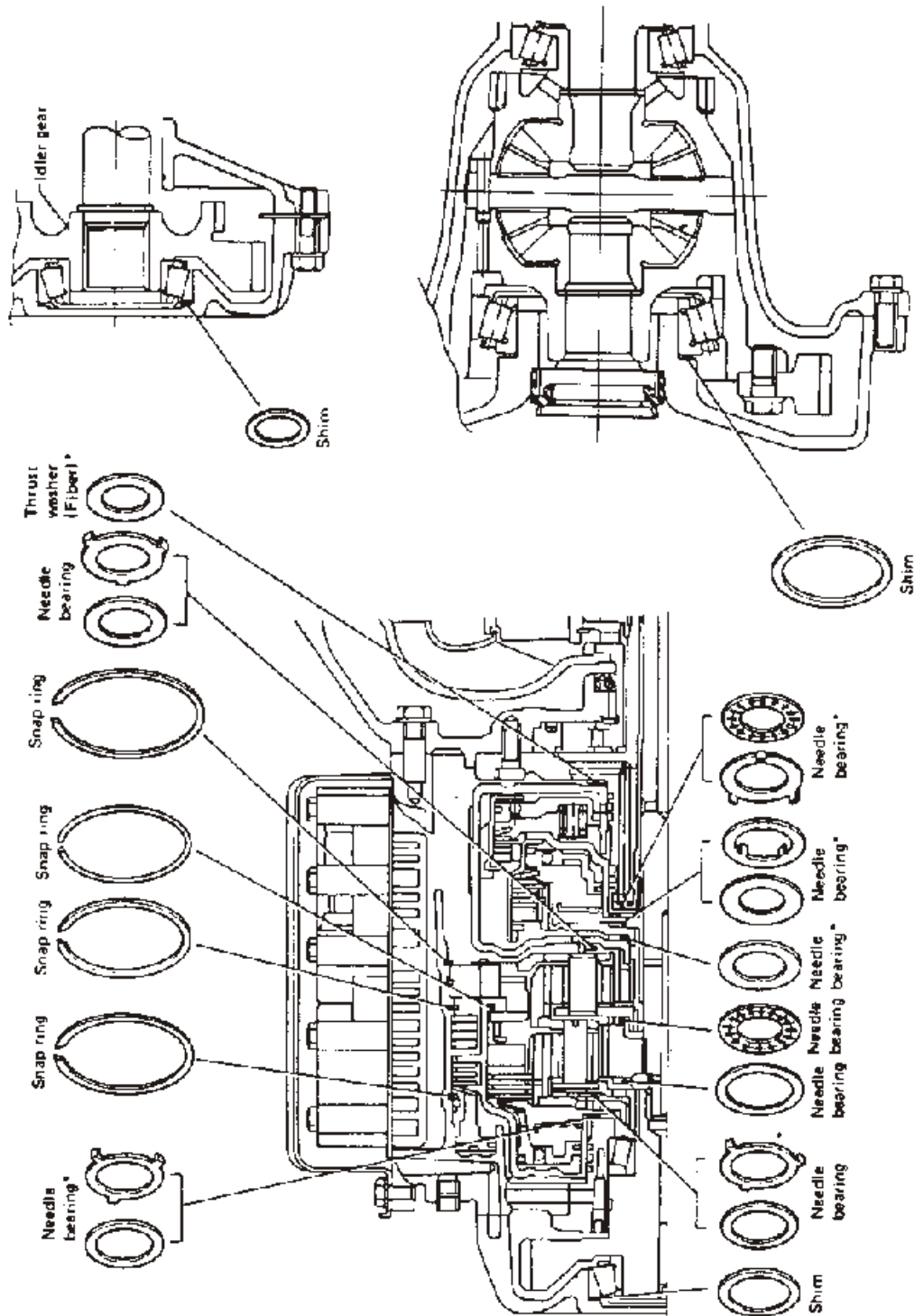

When installing, apply petroleum jelly to parts with "a," so that they will not drop off.

AUTOMATIC TRANSMISSION SERVICE GROUP

1. Install diff. lubrication tube and diff. gutter to converter housing.

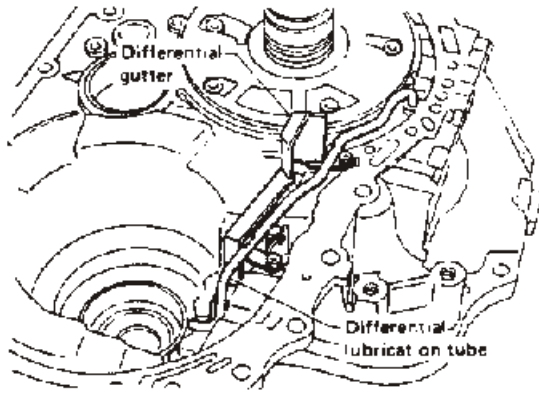

2. Install oil strainer.

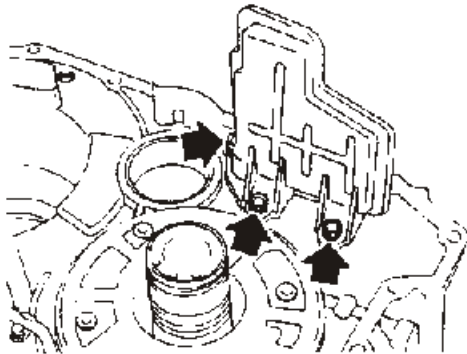

3. Install detent spring assembly.

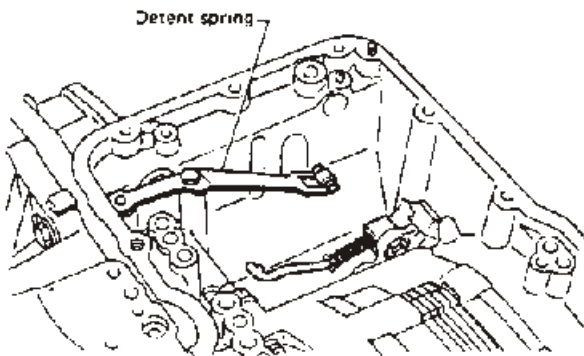

4. Pass parking rod into the hole in the manual plate and then install manual plate on manual shaft.

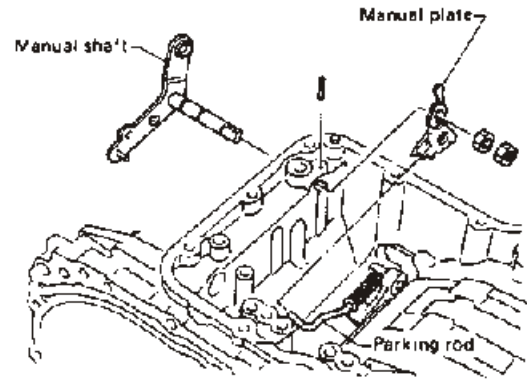

5. Install band brake servo, retainer and return spring and secure with snap ring.

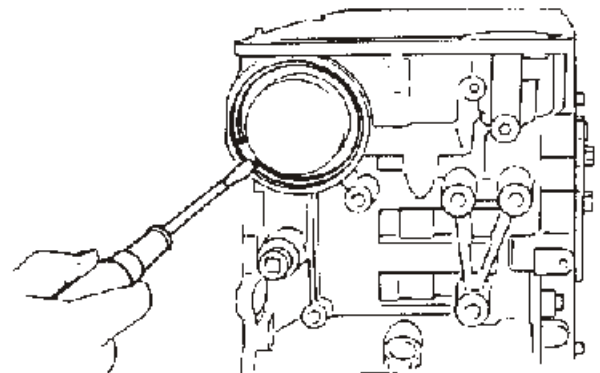
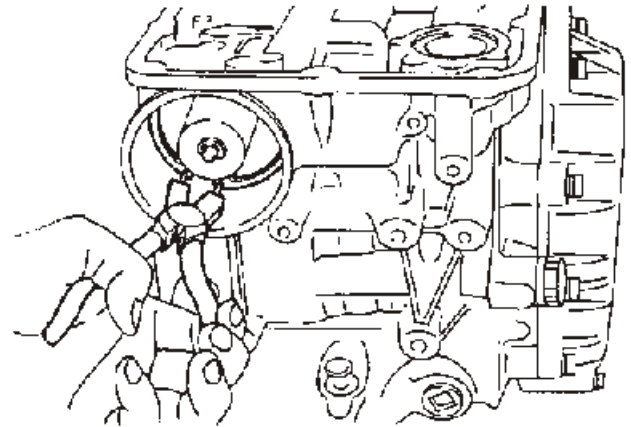

6. Lubricate low and reverse brake piston seal, then install piston by tapping it evenly using a wooden block.

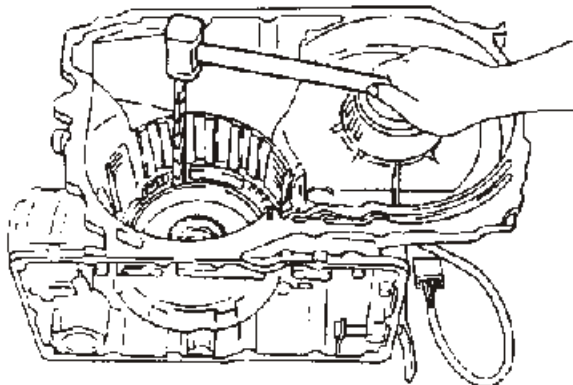

7. Install low and reverse brake retainer, and secure with snap ring.

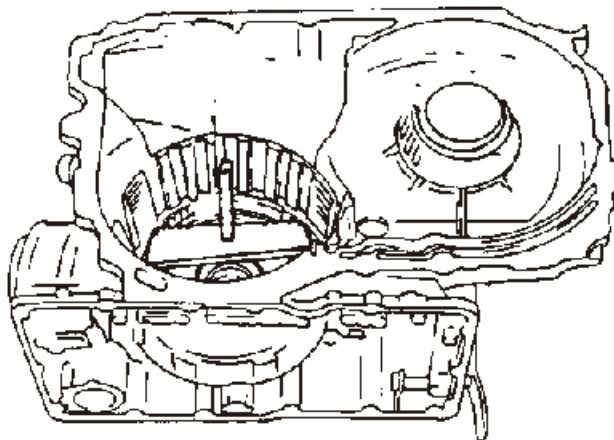

The low clutch and low and reverse brake snap rings are the same size. The one way clutch snap ring is larger in diameter.

8. Install low and reverse brake driven & drive plates and retaining plate, then secure with snap ring.

9. After low and reverse brake has been completely assembled, measure the clearance between snap ring and retainer plate. If measurement exceeds specifications, it can be adjusted by replacing retainer plate with one of a different thickness.

Low and reverse brake clearance:

Standard

2.2 - 2.6 mm (0.087 - 0.102 in)

Allowable limit

4.0 mm (0.157 in)

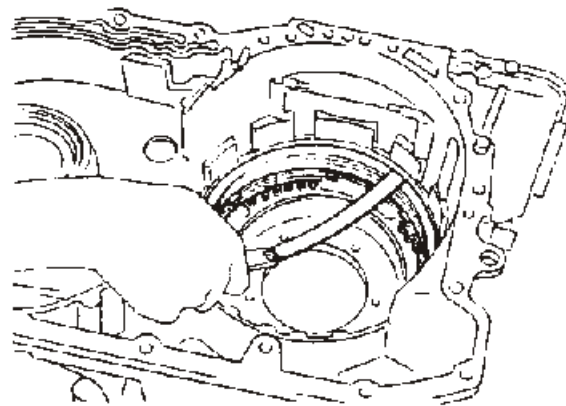

Available retainer plate

Thickness mm (in)	Part number
3.4 (0.134)	31667-21X00
3.6 (0.142)	31667-21X01
3.8 (0.150)	31667-21X02
4.0 (0.157)	31667-21X03
4.2 (0.165)	31667-21X04
4.4 (0.173)	31667-21X05
4.6 (0.181)	31667-21X06
4.8 (0.189)	31667-21X07
5.0 (0.197)	31667-21X08

ASSEMBLY

Check low & reverse brake operation using air.

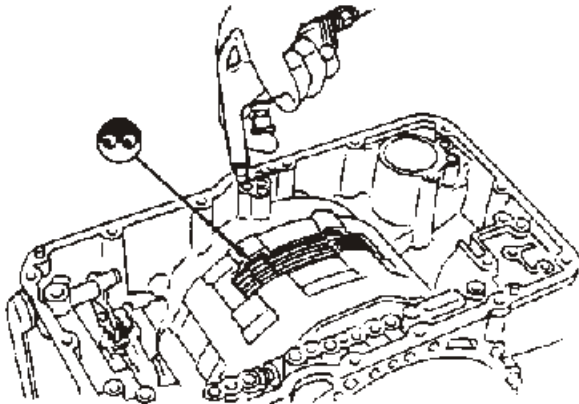

10. Assemble front carrier, rear carrier and low clutch.

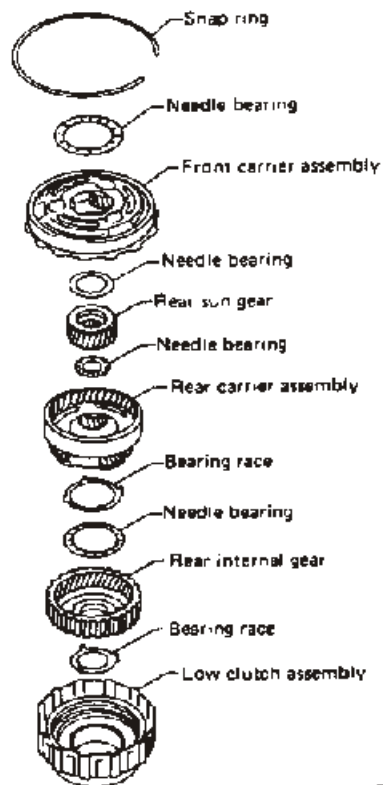

SAT856

11. Install carrier set.

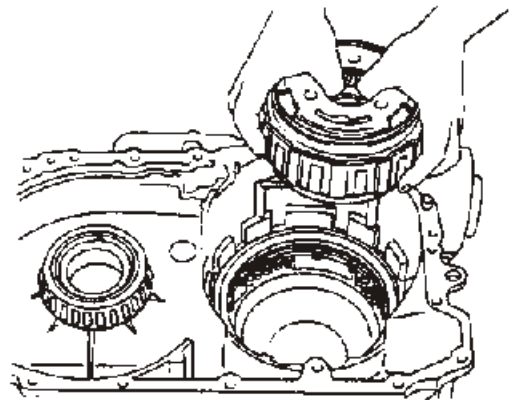

12. Install one-way clutch assembly while rotating front carrier by high clutch hub.

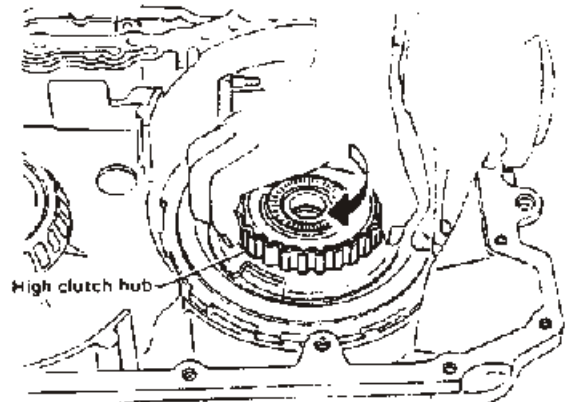

13. Remove high clutch hub, and install clutch snap ring.

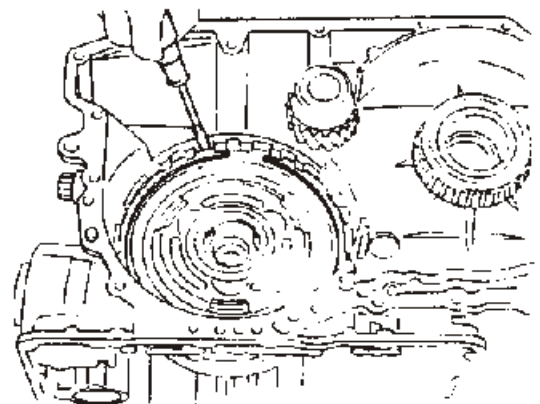

14. Install seal rings onto bearing retainer with great care. Clean the grooves and liberally apply petroleum jelly to hold the rings in place. Otherwise, they could be cut or deformed when the low clutch and carrier assembly are installed.

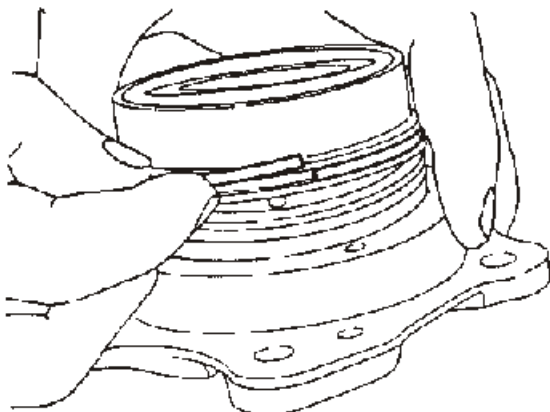

15. Install bearing retainer assembly.

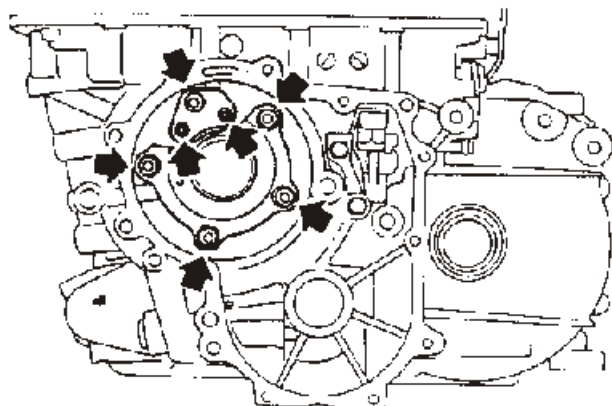

16. Assemble reverse clutch and high clutch.

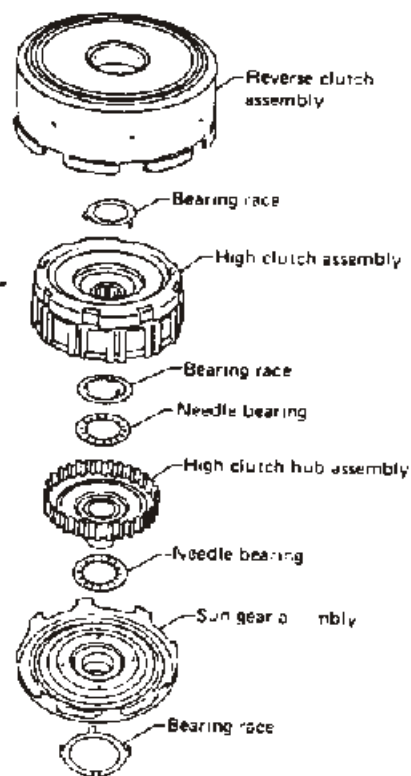

17. Install reverse and high clutch as a pack.

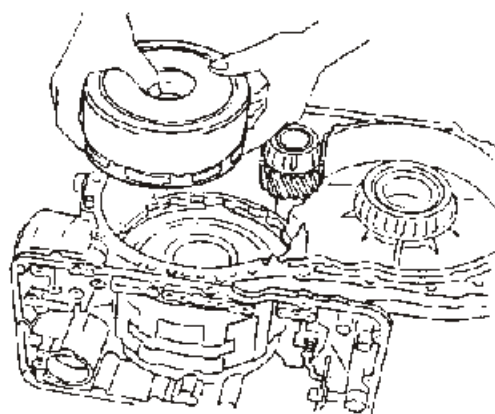

ASSEMBLY

18. Install brake band and anchor pin. Temporarily tighten anchor bolt by hand.

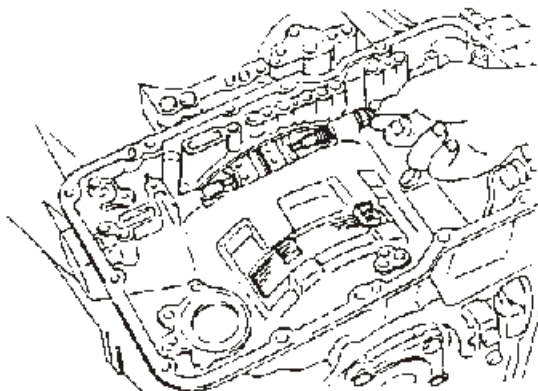

19. Adjust total end play and clutch pack end play as follows.

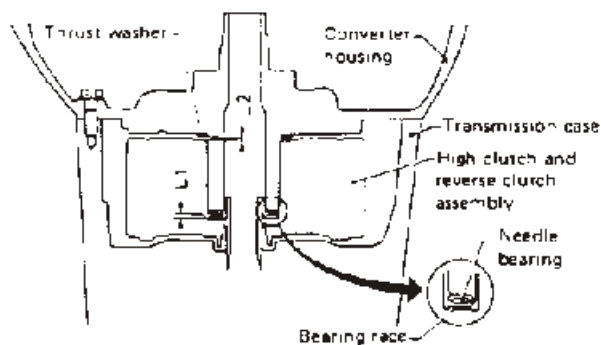

L1: Total end play
L2: Clutch pack end play

Total end play

- 1) Remove the thrust bearing race from the high clutch drum.

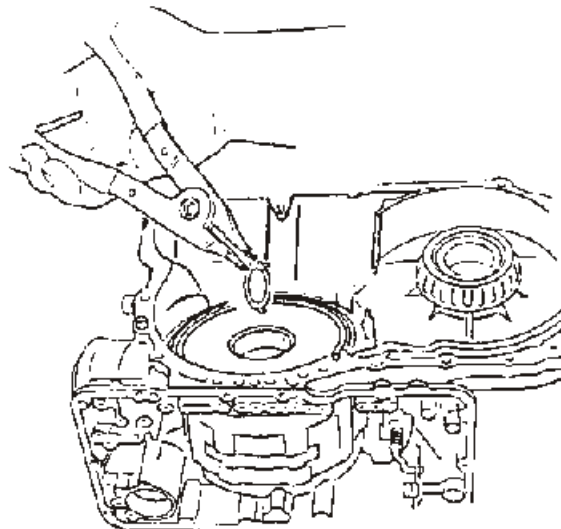

- 2) Install needle bearing on top of oil pump cover.

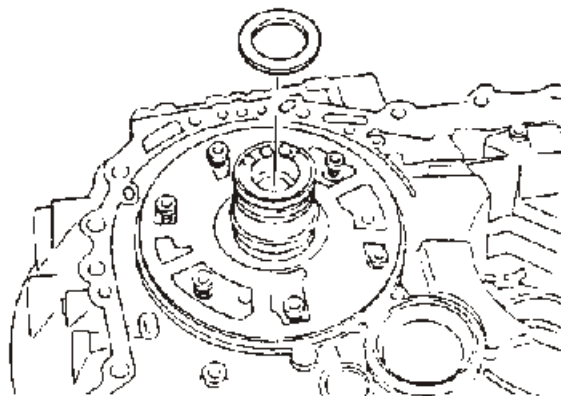

ASSEMBLY

- 3) Place J-34290-1 bridge and J-34290-2 gauging cylinder on the machined gasket surface of the converter housing. Allow the gauging cylinder to rest on the needle bearings and lock it in place with the thumb screw.

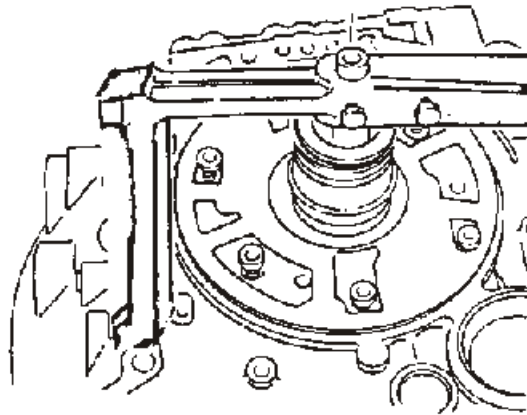

- 4) Insert the J-34290-7 total end play gauging plunger into the gauging cylinder.

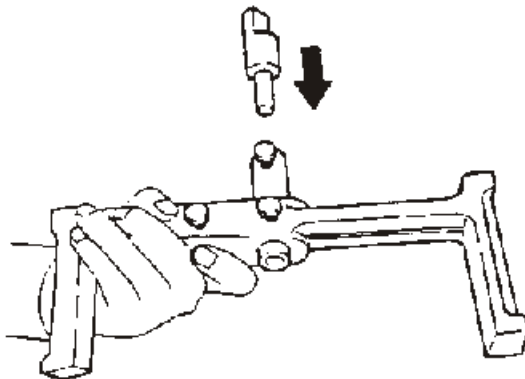

- 5) Place the bridge, legs up, onto the machined gasket surface of the transaxle case, allowing the gauging plunger to rest on the surface where the bearing race was removed. Lock the plunger in place.

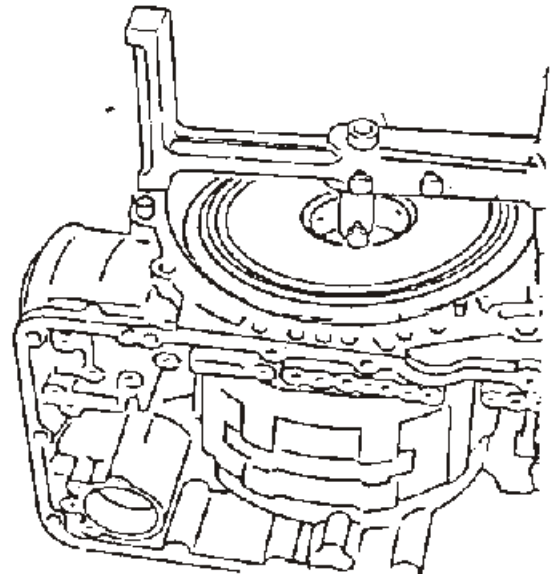

- 6) Remove the bridge and use a feeler gauge to measure the gap between the gauging cylinder and the shoulder of the gauging plunger.

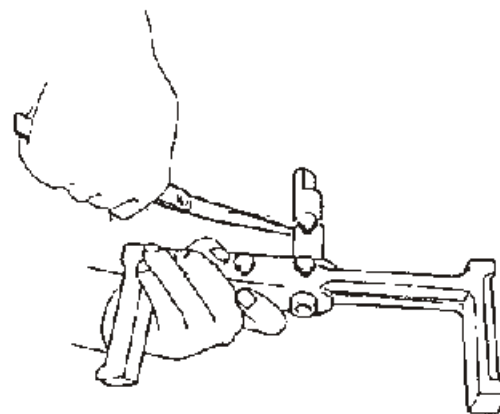

ASSEMBLY

- 7) Use your feeler gauge reading to select the appropriate bearing race thickness from the following chart:

Available oil pump bearing races

Thickness mm (in)	Part number
0.8 (0.031)	31429-21X00
1.0 (0.039)	31429-21X01
1.2 (0.047)	31429-21X02
1.4 (0.055)	31429-21X03
1.6 (0.063)	31429-21X04
1.8 (0.071)	31429-21X05
2.0 (0.079)	31429-21X06

Clutch pack end play

- 1) Place the J-34290-1 bridge and the J-34290-2 gauging cylinder onto the machined gasket surface of the transaxle case and allow the cylinder to rest on the thrust washer surface of the high clutch drum. Lock the cylinder into place.

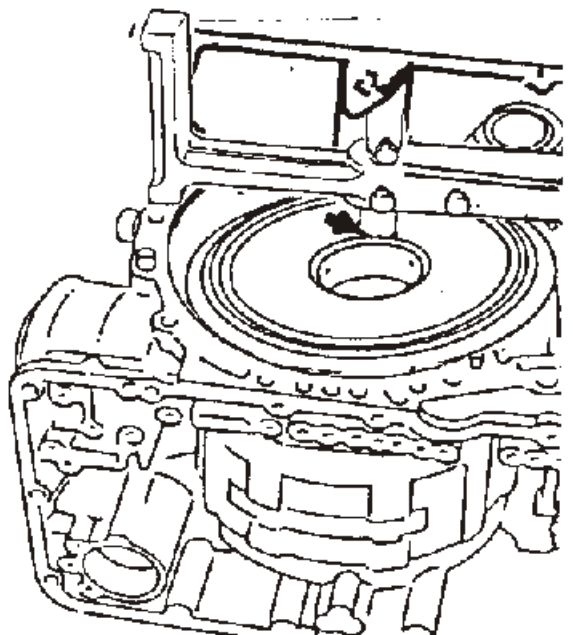

You are now measuring dimension "C".

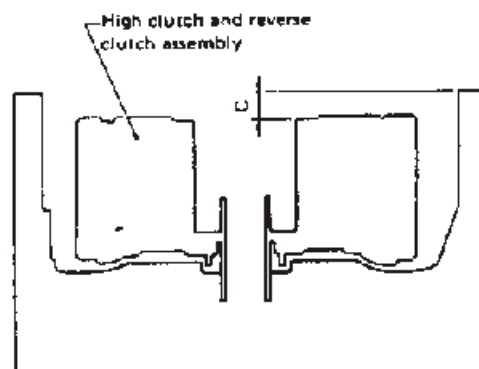

- 2) Now, insert the J-34290-6 clutch pack gauging plunger into the gauging cylinder.

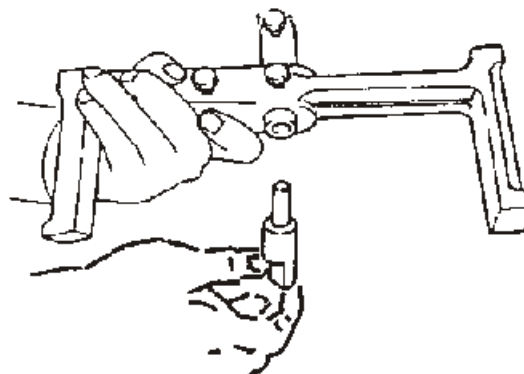

- 3) Place the bridge, gauging cylinder, and gauging plunger onto the machined gasket surface of the converter housing. Make sure the thrust washer is removed. Lock the gauging plunger in place.

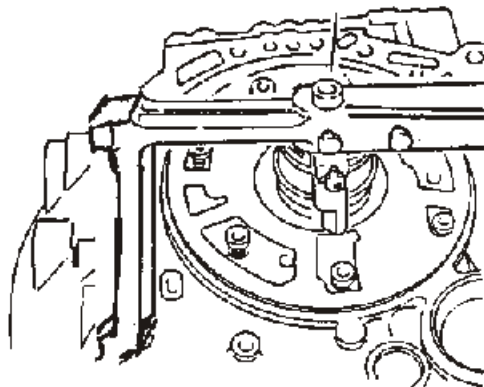

- 4) Use a feeler gauge to measure the gap between the gauging cylinder and the shoulder of the gauging plunger.

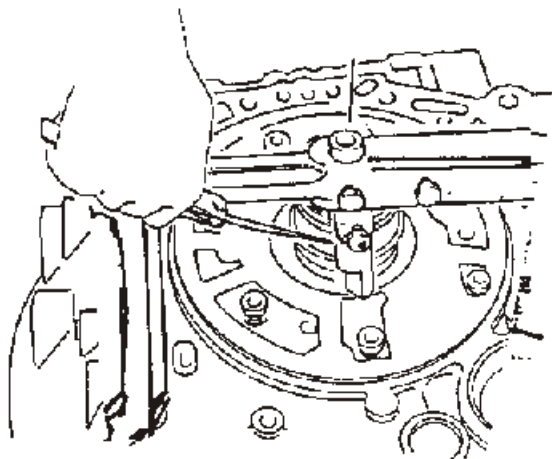

- 5) Use your feeler gauge measurement and the following thrust washer chart to select the correct washer thickness to give the proper clutch pack end play:

Available clutch pack thrust washers

Thickness mm (in)	Part number
0.7 (0.028)	31528-21X00
0.9 (0.035)	31528-21X01
1.1 (0.043)	31528-21X02
1.3 (0.051)	31528-21X03
1.5 (0.059)	31528-21X04
1.7 (0.067)	31528-21X05
1.9 (0.075)	31528-21X06

20. Adjust diff. side bearing preload as follows:

Differential side bearing preload adjusting shim

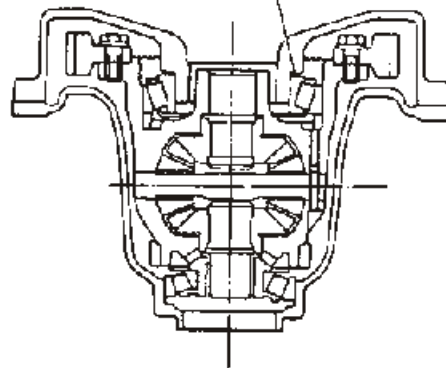

- 1) Remove left side bearing inner cone and shims from the transaxle case.

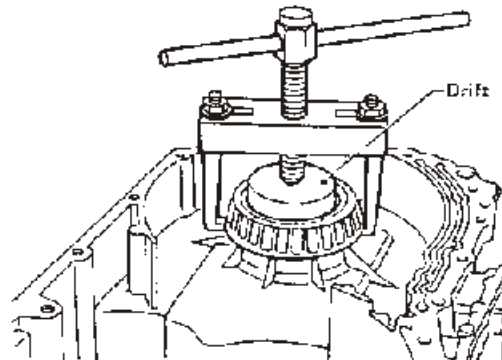

ASSEMBLY

- 2) Place the J-34290-1 bridge and the J-34290-2 gauging cylinder on the machined gasket surface of the transaxle case and allow the gauging cylinder to rest on the bearing mating surface. Lock the gauging cylinder in place.

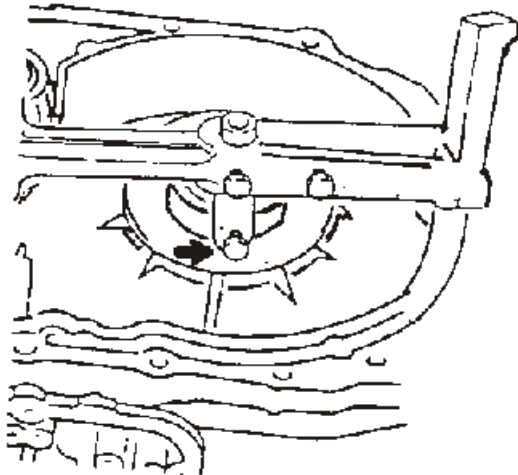

You are now measuring dimension "E".

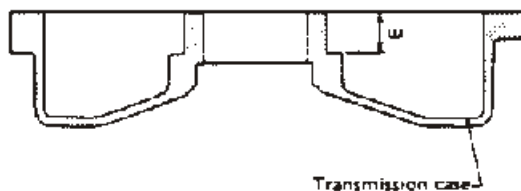

- 3) Put diff. case assembly into converter housing, then put side bearing inner cone on diff. case.

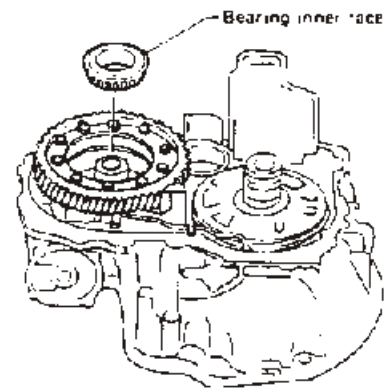

- 4) Hold the inner bearing cone in place while spinning the differential case assembly in order to seat the bearings.
- 5) Insert the J-34290-3 differential side bearing gauging plunger into the gauging cylinder.

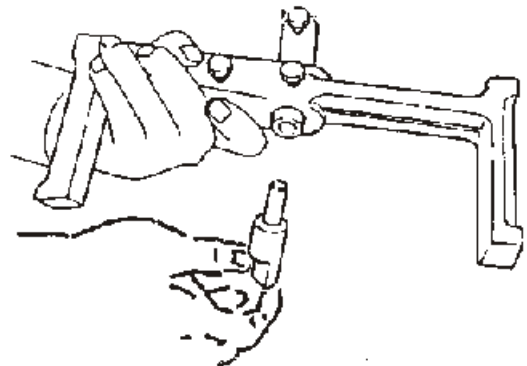

- 6) Place the bridge, gauging cylinder, and gauging plunger onto the machined gasket surface of the converter housing and allow the gauging plunger to rest on the surface of the bearing inner cone. Lock the plunger in place.

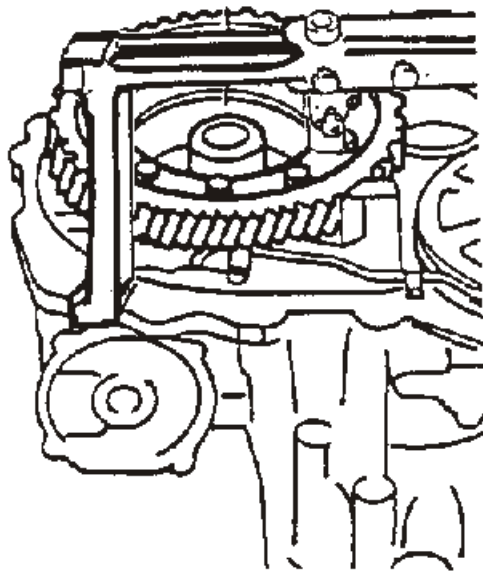

- 7) Use a feeler gauge to measure the clearance between the gauging cylinder and the shoulder of the gauging plunger.

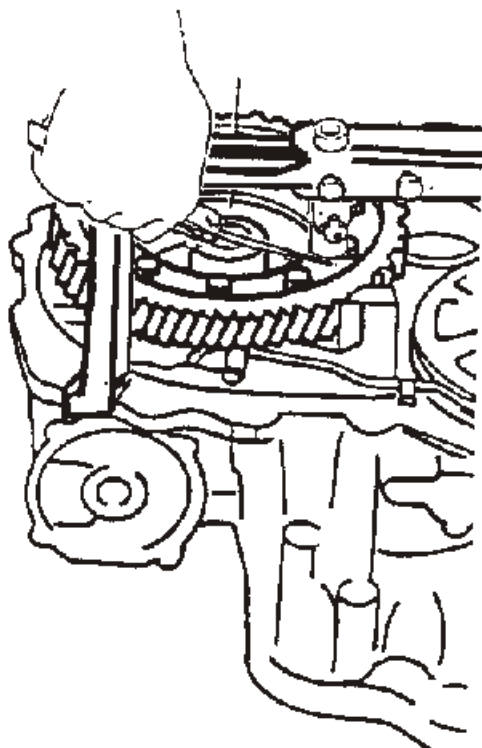

- 8) Use your feeler gauge reading and the following chart to select the appropriate side bearing preload shim(s).

Diff. side bearing preload adjusting shim

Thickness mm (in)	Part number
0.44 (0.0173)	38453-21X00
0.48 (0.0189)	38453-21X01
0.52 (0.0205)	38453-21X02
0.56 (0.0220)	38453-21X03
0.60 (0.0236)	38453-21X04
0.64 (0.0252) *	38453-21X05
0.68 (0.0268)	38453-21X06
0.72 (0.0283)	38453-21X07
0.76 (0.0299)	38453-21X08
0.80 (0.0315)	38453-21X09
0.84 (0.0331)	38453-21X10
0.88 (0.0346)	38453-21X11
0.92 (0.0362)	38453-21X12

- 9) Install selected shim(s) and the left side inner bearing cone onto the transaxle case.

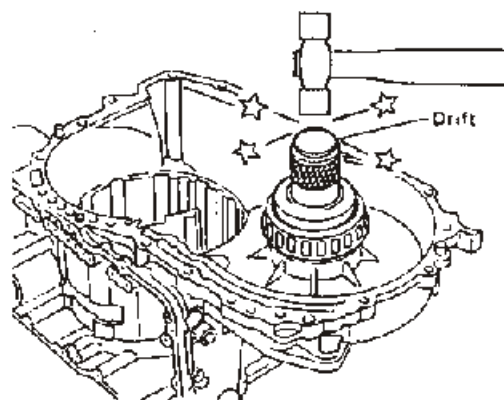

21. Place transmission case onto wooden blocks, and install reduction pinion gear and differential case assembly.

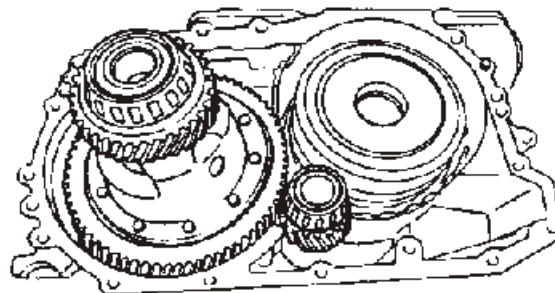

ASSEMBLY

22. Place gasket on transmission case and install converter housing while assuring that reduction pinion gear does not interfere with transmission case.

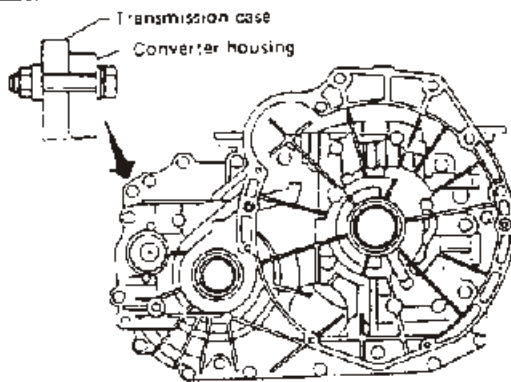
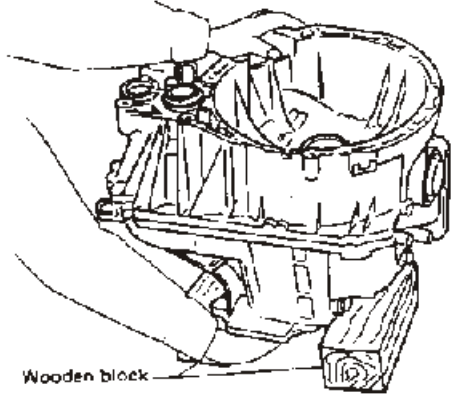

23. Install parking pawl, return spring, pawl shaft and spacer.

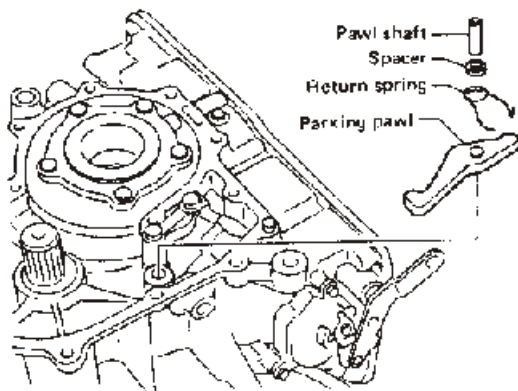

24. Install idler gear.

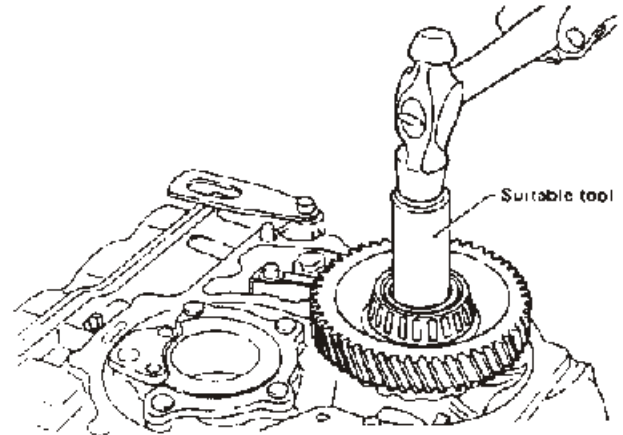

25. Install output gear.

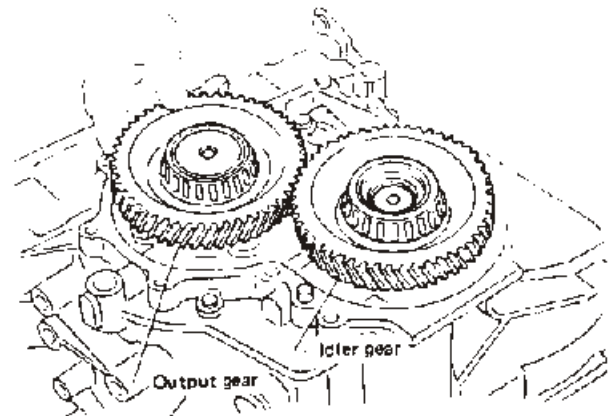

Seal rings of the output gear must be well lubricated with petroleum jelly prior to installation of output gear.

ASSEMBLY

26. Adjust output shaft and idler gear bearing preload as follows:

- 1) Remove output gear and idler gear bearing outer races and shims. (The races will interchange, so be sure to keep each race with its correct bearing.)

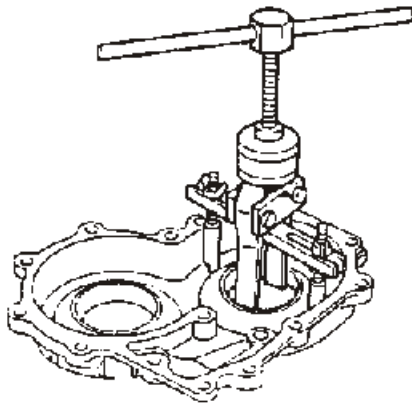

- 2) Place the J-34290-1 bridge with the J-34290-2 gauging cylinder onto the machined gasket surface of the side cover. Allow the gauging cylinder to drop into the output gear bearing race bore until it bottoms. Lock the cylinder in place with the thumbscrew.

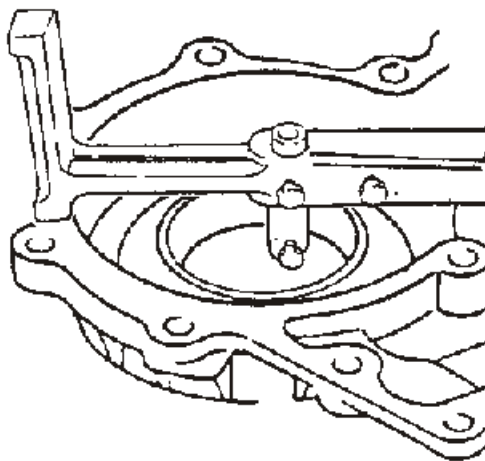

You are now measuring dimension "H" in the following diagram:

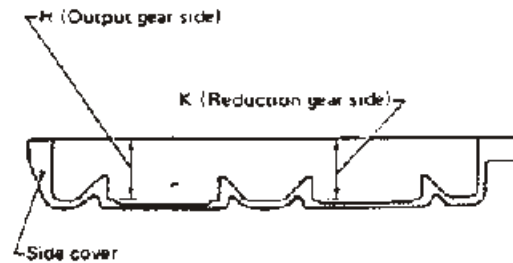

- 3) Put the correct bearing races on the output gear and the idler gear bearings, and turn the races to seat the bearings.
- 4) Place the J-34290-4 output gauging plunger into the gauging cylinder.

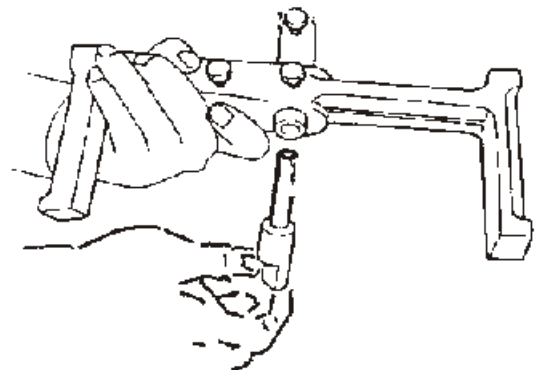

ASSEMBLY

- 5) Now, place the J-34290-1 bridge onto the machined gasket surface of the transaxle case and allow the gauging plunger to drop onto the rear surface of the output gear bearing race.

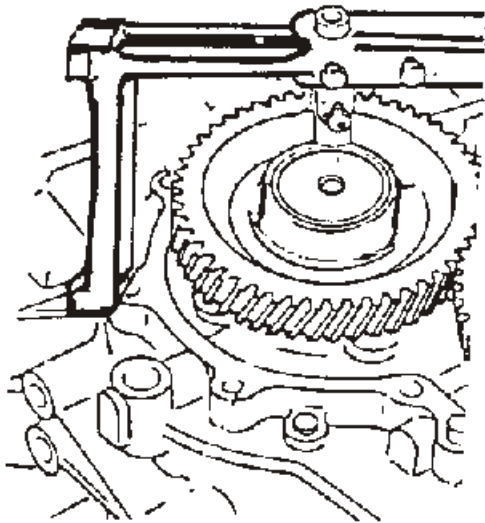

- 6) Lock the gauging plunger in place with the thumbscrew. Use a feeler gauge to measure the gap between the gauging cylinder and the shoulder of the gauging plunger.

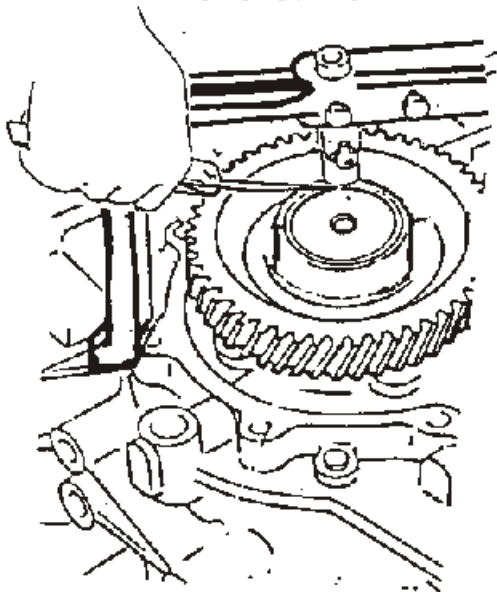

- 7) Use the feeler gauge reading to select the correct shim(s) from the following chart:

Output shaft preload adjusting shim

Thickness mm (in)	Part number
0.12 (0.0047)	31499-21X00
0.16 (0.0063)	31499-21X01
0.20 (0.0079)	31499-21X02
0.24 (0.0094)	31499-21X03
0.28 (0.0110)	31499-21X04
0.32 (0.0126)	31499-21X05
0.36 (0.0142)	31499-21X06
0.40 (0.0157)	31499-21X07
0.44 (0.0173)	31499-21X08
0.48 (0.0189)	31499-21X09
0.52 (0.0205)	31499-21X10
0.56 (0.0220)	31499-21X11
0.60 (0.0236)	31499-21X12
0.64 (0.0252)	31499-21X13
0.68 (0.0268)	31499-21X14
0.72 (0.0283)	31499-21X15
0.76 (0.0299)	31499-21X16
0.80 (0.0315)	31499-21X17
0.84 (0.0331)	31499-21X18
0.88 (0.0346)	31499-21X19
0.92 (0.0362)	31499-21X20
1.44 (0.0567)	31499-21X21
1.96 (0.0772)	31499-21X22

- 8) Now, measure for the correct preload shims at the idler gear-bearing in the same way. Place the bridge onto the machined surface of the side cover and allow the gauging cylinder to drop until it contacts the idler bearing race mating surface.

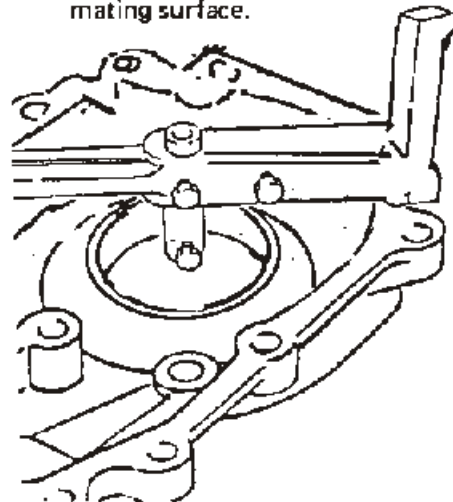

ASSEMBLY

You are now measuring dimension "K".

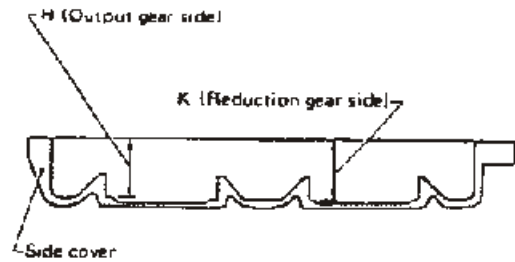

- 9) Lock the gauging cylinder in place. Insert the J-34290-3 gauging plunger into the gauging cylinder and place the bridge onto the machined surface of the case, so that the gauging plunger meets the idler bearing race rear surface.

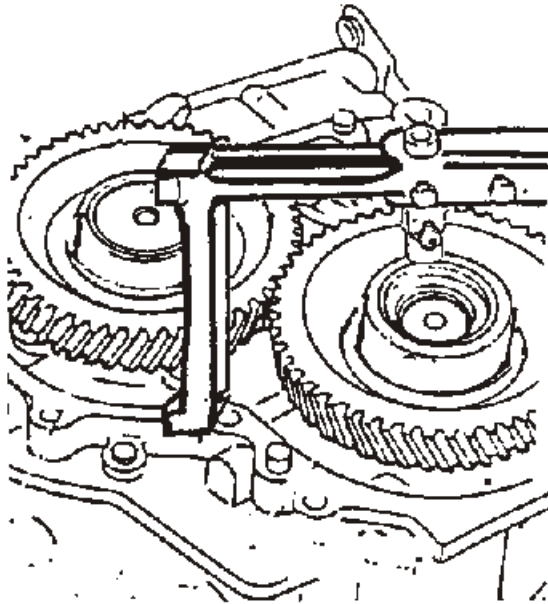

- 10) Lock the gauging plunger in place and use a feeler gauge to measure the gap between the gauging cylinder and the gauging plunger.

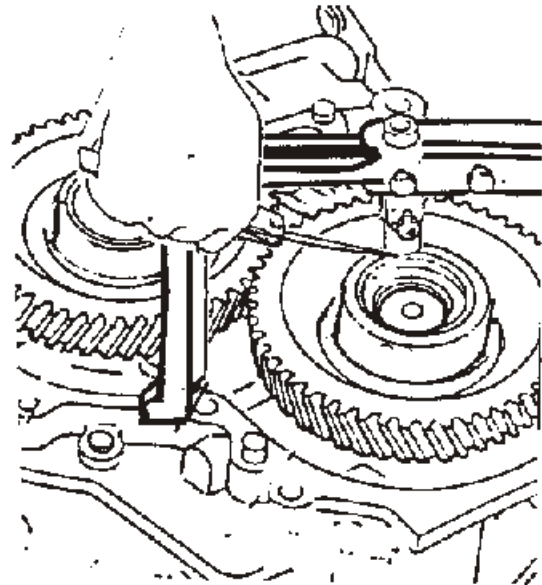

- 11) Use your measured distance and the following chart to select the correct shim(s) for idler gear bearing preload.

Idler gear preload adjusting shim

Thickness mm (in)	Part number
0.36 (0.0142)	31499-21X06
0.40 (0.0157)	31499-21X07
0.44 (0.0173)	31499-21X08
0.48 (0.0189)	31499-21X09
0.52 (0.0205)	31499-21X10
0.56 (0.0220)	31499-21X11
0.60 (0.0236)	31499-21X12
0.64 (0.0252)	31499-21X13
0.68 (0.0268)	31499-21X14
0.72 (0.0283)	31499-21X15
0.76 (0.0299)	31499-21X16
0.80 (0.0315)	31499-21X17
0.84 (0.0331)	31499-21X18
0.88 (0.0346)	31499-21X19
0.92 (0.0362)	31499-21X20
1.44 (0.0567)	31499-21X21
1.96 (0.0772)	31499-21X22

ASSEMBLY

12) Install selected shim(s) and bearing outer races.

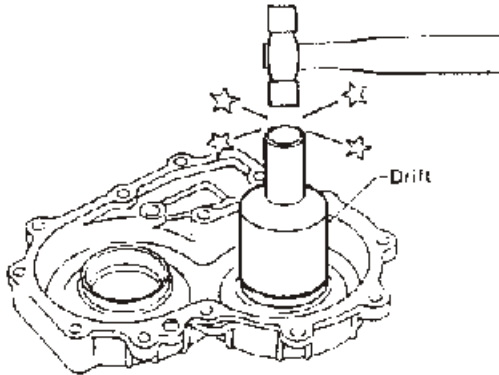

27. Install side cover and gasket.

28. Move manual lever until parking pawl engages idler gear. Measure clearance between parking pawl and parking actuator.

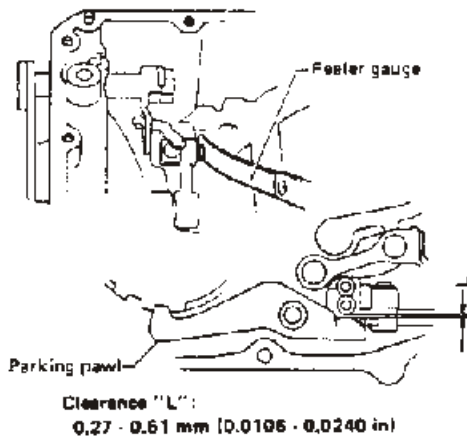

If clearance is outside specifications, replace parking pawl.

Part number	Identification letter
31989-21X00	D
31989-21X01	E
31989-21X02	F

Example:

When parking pawl with identification letter "E" is used:

Clearance "L" is larger → Replace with parking pawl with identification letter "D".

Clearance "L" is smaller → Replace with parking pawl with identification letter "F".

Parking pawl

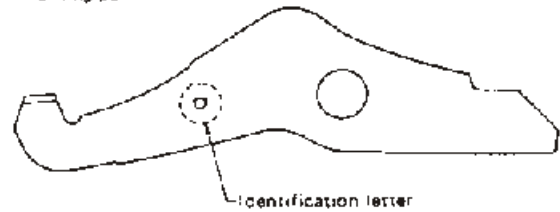

29. Install input shaft as far as it will go. Then, measure distance "L" as shown below.

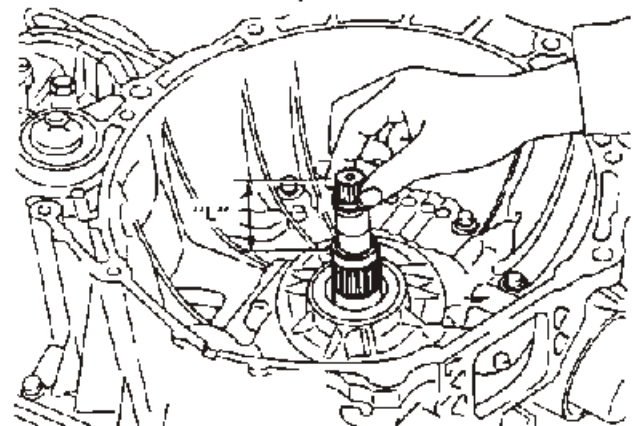

Distance "L":

29 - 31 mm (1.14 - 1.22 in)

Do not tap the input shaft with hammer.

30. Insert Tool into final drive portion to see if internal parts rotate smoothly. Rotating in direction "B" should be slightly harder than in direction "A".

If abnormalities are noted, proceed with the following.

- Disassemble parts to see if they are properly assembled.

ASSEMBLY

- Readjust bearing preloads of final drive, output shaft and idler gear.

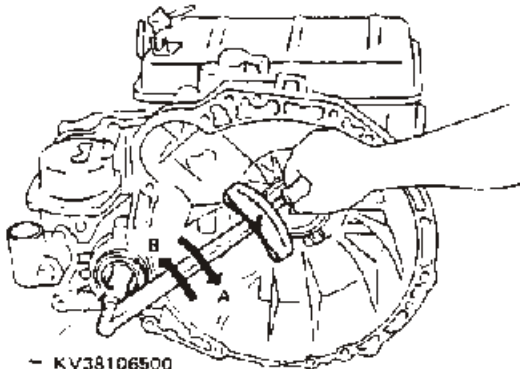

- KV38106500
(J-34284)

31. Adjust brake band.

- 1) First tighten anchor end pin.

 : Anchor end pin
4 - 6 N·m
(0.4 - 0.6 kg·m, 2.9 - 4.3 ft·lb)

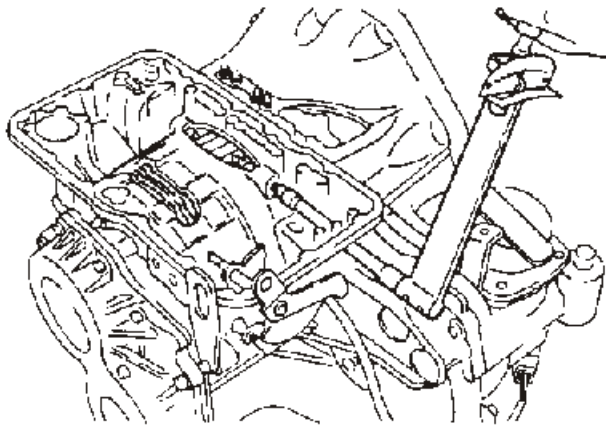

- 2) Back off anchor end pin 5-1/4 turns.
- 3) Tighten lock nut while holding anchor end pin stationary.

 : Lock nut
31 - 42 N·m
(3.2 - 4.3 kg·m, 23 - 31 ft·lb)

32. Install terminal assembly while paying attention to the direction of its hook.

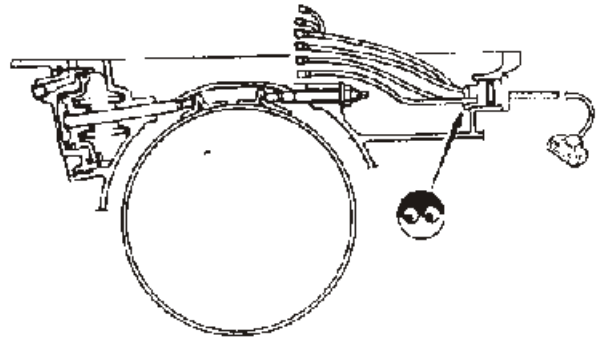

33. Install accumulator and spring.

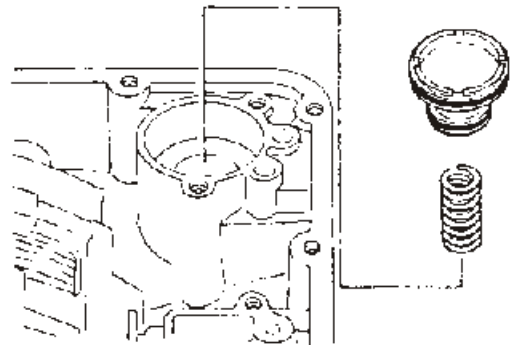

34. Install throttle shaft and return spring.

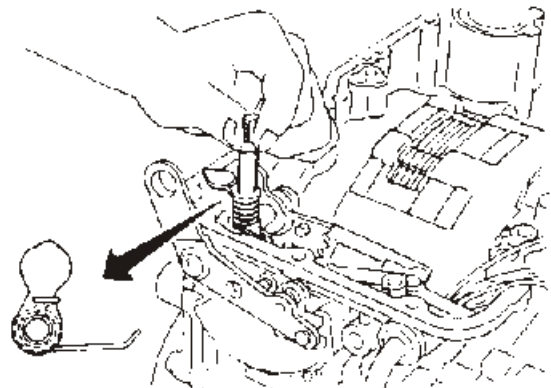

ASSEMBLY

35. Insert manual valve to control valve body, then assemble them to transmission case.

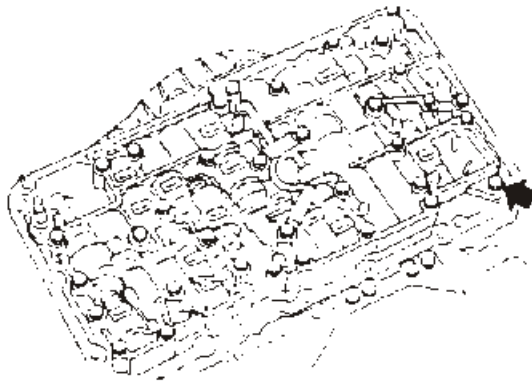
**Arrow marks:**

3.7 - 5.0 N·m
(0.38 - 0.51 kg-m, 2.7 - 3.7 ft·lb)

Others:

7 - 9 N·m
(0.7 - 0.9 kg-m, 5.1 - 6.5 ft·lb)

- Pay attention to the direction of manual and detent valves' grooves.

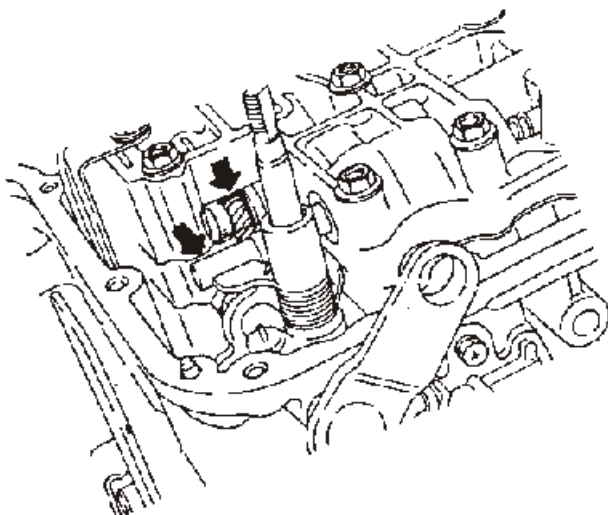

36. Set throttle shaft return spring as shown below.

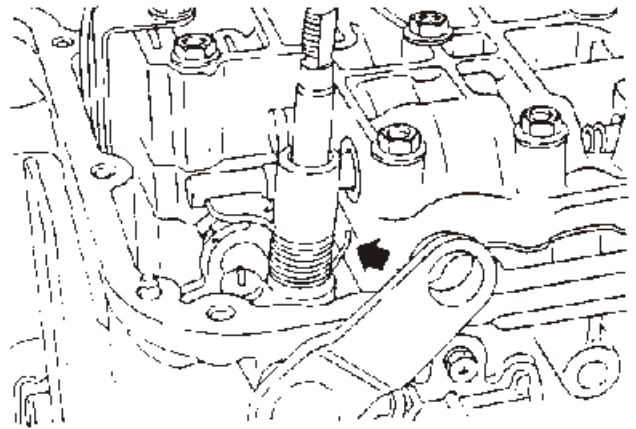

37. Connect harness connectors between terminal assembly and solenoids.

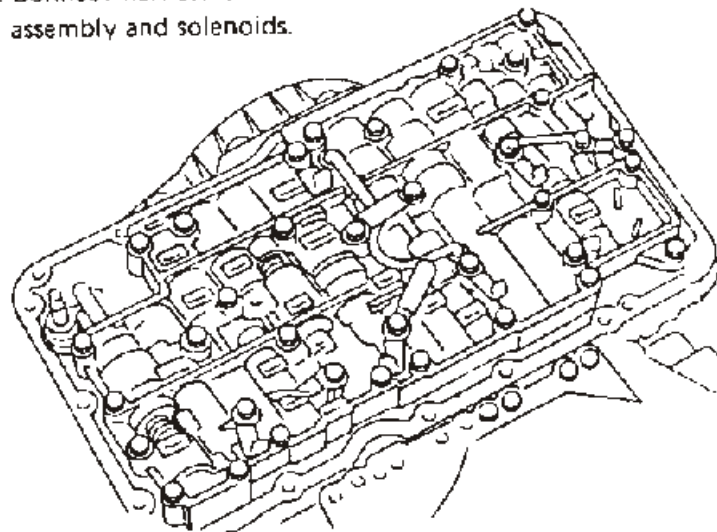

38. Put gasket on transmission case and install valve cover and throttle lever.

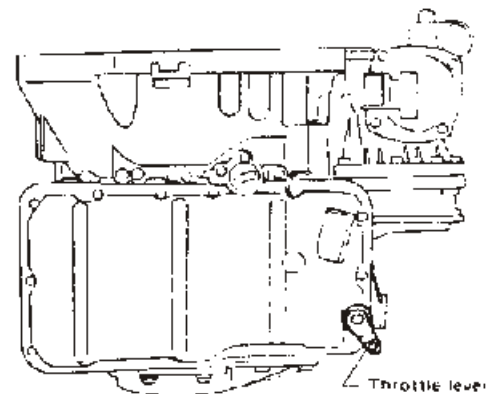

39. Install control cylinder.

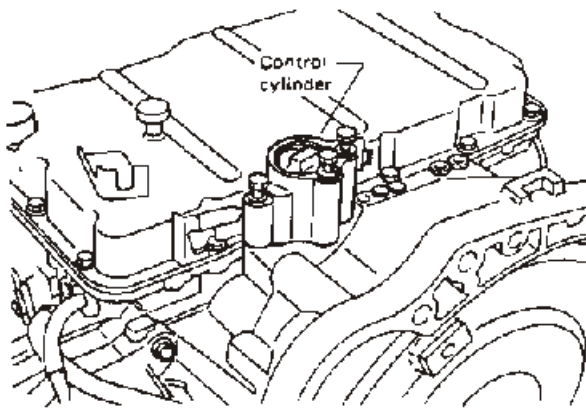

40. Install governor parts.

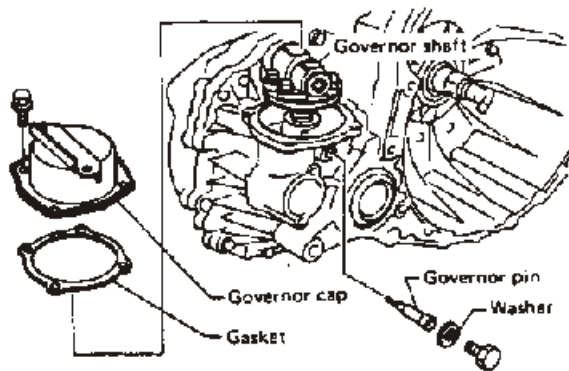

41. Install speedometer parts.

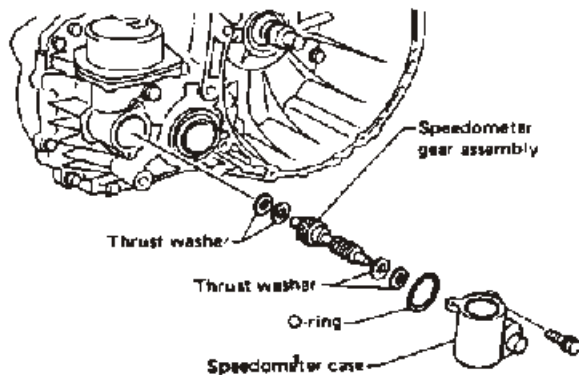

42. Pour approximately 2-liters (2-1/8 US qt, 1-3/4 Imp qt) of automatic transmission fluid into converter housing.

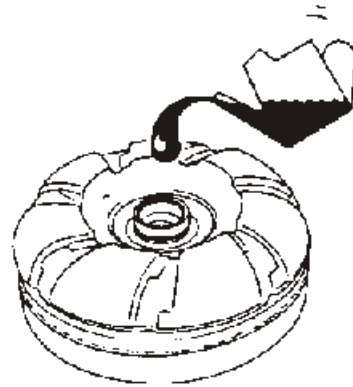

43. Install torque converter to converter housing. To install it correctly, refer to REMOVAL AND INSTALLATION (AT-13).

Be careful not to scratch front oil seal.

44. Apply sealant to threads of drain plug and install it in place.

45. Install inhibitor switch to transmission case.

46. Adjust inhibitor switch. Refer to On-vehicle Service.

47. Make sure that manual lever operates smoothly.



TROUBLE-SHOOTING AND DIAGNOSES

Preliminary Checks (Prior to Road Testing)

FLUID LEAKAGE

If the governor cap is suspected:

- 1) Open hood.
- 2) Remove snap retainer, governor cap and seal ring, then reinstall them. Refer to ON-VEHICLE SERVICE.
- 3) Clean the area around the governor cap.
- 4) Run the vehicle at highway speeds.
- 5) Check the governor cap for fresh leakage.

To detect a fluid leak:

- 1) Raise vehicle.
- 2) Clean area suspected of leaking.
- 3) Start engine, apply foot brake, place shift control lever in drive, and wait a few minutes.
- 4) Stop engine.
- 5) Check for fresh leakage.

FLUID CONDITION

Examine the A.T.F. and note its color, texture, and odor.

- 1) Dark or Black Fluid with a burned odor:
 - Worn friction material
- 2) Milky Pink Fluid: Water Contamination
 - Road water entering through filter tube or breather.
- 3) Varnished Fluid, light to dark brown and tacky: Oxidation
 - Over or Underfilling.
 - Overheating.

Road Testing

Perform road tests using "Symptom" chart, as follows:

"P" RANGE

1. Place shift control lever in "P" range and start the engine. Stop the engine and repeat the procedure in all other ranges including neutral.
2. Stop vehicle on a slight upgrade and place selector lever in "P" range. Release parking brake to make sure vehicle remains locked.

"R" RANGE

1. Manually shift the selector lever from "P" to "R", and note shift quality.
2. Drive the vehicle in reverse long enough to detect slippage or other abnormalities.

"N" RANGE

1. Manually shift the selector lever from "R" and "D" to "N" and note quality.
2. Release parking brake with selector lever in "N" range. Lightly depress accelerator pedal to make sure vehicle does not move. (When vehicle is new or soon after clutches have been replaced, vehicle may move slightly. This is not a problem.)

"D" RANGE

1. Manually shift the selector lever from "N" to "D" range, and note shift quality.

AUTOMATIC TRANSMISSION SERVICE GROUP

Road Testing (Cont'd)

- Using the shift schedule as a reference, drive vehicle in "D" range. Record, on symptom chart, respective vehicle speeds at which upshifting and downshifting occur. These speeds are to be read at three different throttle positions (light, half and full), respectively. Also determine the timing at which shocks are encountered during shifting and which clutches are engaged.

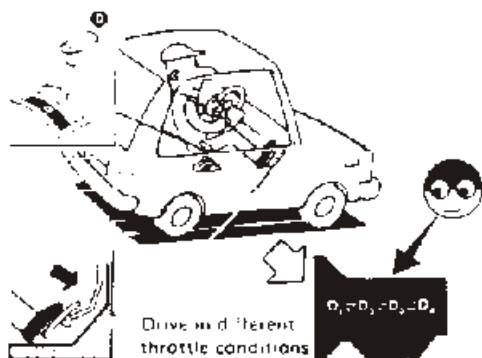

5AT889

- Determine, by observing lock-up pressure, whether lock-up properly occurs while driving vehicle in "D4" range. (Refer to Pressure Testing, page A7-70).
- Check to determine if shifting to overdrive gear cannot be made while O.D. control switch is "OFF".

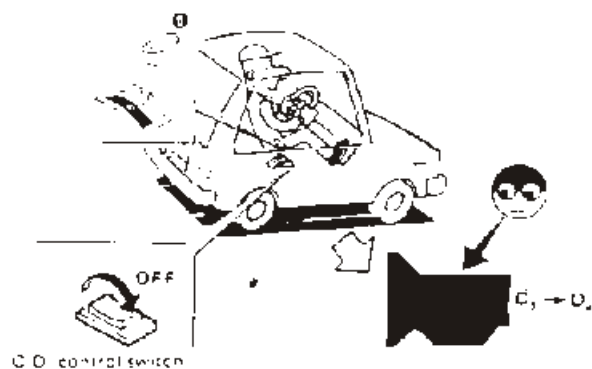

5AT890

- When vehicle is being driven in the 65 to 80 km/h (40 to 50 MPH) range in "D₃" at half to light throttle position, fully depress accelerator pedal to make sure the transmission downshifts from 3rd to 2nd gear.
- When vehicle is being driven in the 25 to 35 km/h (16 to 22 MPH) ("D₂" range) at half to light throttle position, fully depress accelerator pedal to make sure the transmission downshifts from 2nd to 1st gear.

"2" RANGE

- Shift to "2" range and check to make sure that vehicle starts to move in 1st gear.
- Increase vehicle speed to make sure it upshifts from 1st to 2nd gear.
- Further increase vehicle speed. Make sure it does not upshift to 3rd gear.
- While driving vehicle at 25 to 35 km/h (16 to 22 MPH) with throttle at half to light position ("2" range), fully depress accelerator pedal to make sure it downshifts from 2nd to 1st gear.
- Allow vehicle to run at idle while in 2nd gear to make sure that it downshifts to 1st gear.
- Shift control lever to "D" range and allow vehicle to operate at 40 to 50 km/h (25 to 31 MPH). Then, shift to "2" range to make sure it downshifts to 2nd gear.

"1" RANGE

- Shift selector lever into "1" range and accelerate vehicle. Ensure that it does not upshift from 2nd to 3rd gear although vehicle speed increases.
- While vehicle is being driven in "1" range, release accelerator pedal to make sure that engine compression acts as a brake.
- Shift selector lever into "D" or "2" range and allow vehicle to run at 20 to 30 km/h (12 to 19 MPH). Then, shift selector lever to "1" range to make sure the downshift to 1st gear is made.



Technical Service Information

Road Testing (Cont'd)

ROAD TEST SYMPTOM CHART

Numbers in chart below correspond with those indicated in Trouble-shooting chart

			SHIFT QUALITY				VEHICLE WON'T MOVE	CRUISE SLIPPAGE	POOR POWER/ACCELERATION	NOISY	ENGINE WON'T START	VEHICLE WON'T STAND STILL	NO ENGINE BRAKING	NO LOCK-UP	COMMENTS
			ROUGH	SHIFT TIMING (Mark Am/h (MPH))	NO SHIFT	SHIFT SLIPPAGE									
PARK RANGE	ENG START									A					
	HOLDING									B		C			
"P" RANGE	Man. shift (Vehicle at halt) P-R					Z			(A1)						
	REVERSE					E Z	E	E	(A1)						
"N" RANGE	Man. shift (Vehicle at halt) R-N								(A1)						
	ENG START									A					
	N								B		D				
"D" RANGE	Man. shift N-D1		F			G Z			(A1)						
	1st					G Z		I	(A1)						
	Auto shift 1-2		M	J	P				(A1)						
	2nd								(A1)						
	Auto shift 2-3		N	K	O				(A1)						
	3rd (TCoat)								(A1)						
	Auto shift 3-4		U	L	H				(A1)						
	4th (D.D.I)							S	(A1)						
	Lock-up OFF → "ON"				(A7)				(A1)				(A8)		
	Lock-up "ON" → "OFF"								(A1)						
	Decel 4-3			T					(A1)						
	Kickdown 4-3			T W	X				(A1)						
	Decel 3-2			U					(A1)						
	Kickdown 3-2			U	Y				(A1)						
Decel 2-1			V					(A1)							
Kickdown 2-1			V					(A1)							
"2" RANGE	Man. shift (Vehicle in operation) 0-2			U (A2)		H Z			(A1)						
	1st					H Z		I	(A1)						
	Auto shift 1-2		Q	J	P				(A1)						
	2nd								(A1)						
	Decel 2-1			V					(A1)						
Kickdown 2-1			V					(A1)							
"1" RANGE	Man. shift (Vehicle in operation) 2-1		(A5)	V (A4)					(A1)						
	Man. shift (Vehicle in operation) D1		(A5)	V (A4)					(A1)						
	Acceleration					H Z		I	(A1)						
	"1" Engine Braking								(A1)		(A3)				

AUTOMATIC TRANSMISSION SERVICE GROUP



Road Testing (Cont'd)

TROUBLE-SHOOTING CHART

Numbers are arranged in order of probability. Perform inspections starting with number one and working up. Circled numbers indicate that the transaxle must be removed from the vehicle.

Reference		ON VEHICLE							OFF VEHICLE															
		Oil level	Control cable	Ignition switch and wiring	Throttle wire	Engine idling rpm	Ling pressure	Control valve	Governor valve	Oil quality	Ignition switch and starter motor	Engine adjustment, brake inspection	Oil pump	High clutch	Low clutch	Reverse clutch	Low & reverse brake	Band brake	Transaxle one way clutch	Final drive	Seals/leak	Oil passage leak	Park linkage	Torque converter
A	Engine does not start in "N", "P" ranges.	2	3						1															
	Engine starts in range other than "N" and "P".	1	2																					
B	Transaxle noise in "P" and "N" ranges.	1				2						3												
C	Vehicle moves when changing into "P" range or parking gear does not disengage when shifted out of "P" range.	1																				2		
D	Vehicle runs in "N" range.	1						3	2				4											
E	Vehicle will not run in "R" range (but runs in "D", "2" and "1" ranges). Clutch slips. Very poor acceleration.	1	2			3		5	4				8	6	7							9		
	Vehicle braked when shifting into "R" range.								1				4	2	3	5							6	
F	Sharp shock in shifting from "N" to "D" range.				2	1	3	4																
G	Vehicle will not run in "D" range (but runs in "2", "1" and "R" ranges).	1				2		3										4						
H	Vehicle will not run in "D", "1", "2" ranges (but runs in "R" range). Clutch slips. Very poor acceleration.	1	2			4		5	3		6		8	7								9		
	Clutches or brakes slip somewhat in starting.	1	2		6	3		5	4			7										8		
	Excessive creep				1																			
	No creep at all	1	2			3		5	4			6	8									7	9	
J	Failure to change gear from "1st" to "2nd".	1		2				4	5	3					6							7		
K	Failure to change gear from "2nd" to "3rd".	1		2				4	5	3					6							7		
L	Failure to change gear from "3rd" to "4th".	1		2				4	5	3					6			7						
	Too high a gear change point from "1st" to "2nd", from "2nd" to "3rd", from "3rd" to "4th".				1	2		4	5	3												6		
	Gear change directly from "1st" to "3rd" occurs.							2	3	1							4					5		
	Engine stops when shifting lever into "D" range.										1													
M	Too sharp a shock in change from "1st" to "2nd".				1	3		4	2									5						
N	Too sharp a shock in change from "2nd" to "3rd".				1	3		4	2				5											

AUTOMATIC TRANSMISSION SERVICE GROUP

Road Testing (Cont'd)

Numbers are arranged in order of probability. Perform inspections starting with number one and working up. Circled numbers indicate that the transaxle must be removed from the vehicle.

Reference		ON VEHICLE							OFF VEHICLE															
		Oil level	Control cable	Inhibitor switch and wiring	Throttle wire	Engine idling rpm	Line pressure	Control valve	Control valve	Oil quality	Ignition switch and starter motor	Engine adjustment, brake inspection	Oil pump	High clutch	Low clutch	Reverse clutch	Low & reverse brake	Hand brake	Transaxle one-way clutch	Final drive	Sale/roads	Oil passage leak	Park linkage	Torque converter
Ⓞ	Too sharp a shock in change from "3rd" to "4th".				1	3	4	2								5								
Ⓟ	Almost no shock or clutches slipping in change from "1st" to "2nd".	1	2	3	4	6	5								7							8		
Ⓠ	Almost no shock or slipping in change from "2nd" to "3rd". Engine races extremely fast.	1	2	3	4	6	5					7										8		
Ⓡ	Almost no shock or slipping in change from "3rd" to "4th".	1	2	3	4	6	5								7							8		
	Vehicle braked by gear change from "1st" to "2nd".					2	1					3		4	5	6								
	Vehicle braked by gear change from "2nd" to "3rd".					2	1								3									
	Vehicle braked by gear change from "3rd" to "4th".					2	1					3												
Ⓢ	Maximum speed not attained. Acceleration poor.	1	2		4	5	6	3	7	8	9				10									11
Ⓣ	Failure to change gear from "4th" to "3rd".			1		3	4	2				5			6							7		
Ⓤ	Failure to change gear from "3rd" to "2nd" or from "4th" to "2nd".			1		3	4	2							5							6		
Ⓥ	Failure to change gear from "2nd" to "1st" or from "3rd" to "1st".			1		3	4	2							6	5								
	Gear change shock felt during deceleration by releasing accelerator pedal.		1	2	3	4	5															6	7	
	Too high a change point from "4th" to "3rd", from "3rd" to "2nd", from "2nd" to "1st".		1	2	3	4	5															5		
Ⓦ	Kickdown does not operate when depressing pedal in "4th" within kickdown car speed.			1		3	4	2						6		5						7		
	Kickdown operates or engine overruns when depressing pedal in "4th" beyond kickdown vehicle speed limit.		1	2	3	5	6	4			7				8							9		
Ⓧ	Races extremely fast or slips in changing from "4th" to "3rd" when depressing pedal.			1	2	4	3					5			6									7
Ⓨ	Races extremely fast or slips in changing from "3rd" to "2nd" when depressing pedal.				2	4	3					5			6									



Road Testing (Cont'd)

Numbers are arranged in order of probability. Perform inspections starting with number one and working up. Circled numbers indicate that the transaxle must be removed from the vehicle.

Reference		ON VEHICLE								OFF VEHICLE																	
		Oil level	Control cable Inhibitor switch and wiring	Throttle wire	Engine idling rpm	Line pressure	Control valve	Governor valve	Oil quality	Ignition switch and starter motor	Engine adjustment, brake inspection	O.D. control switch and wiring	O.D. indicator switch	Oil pump	High clutch	Low clutch	Reverse clutch	Low & reverse brake	Band brake	Transaxle one-way clutch	Final drive	Solenooids	Oil passage leak	Park linkage	Torque converter	Planetary gear	Lube control
Z	Vehicle will not run in any range.	1	2			3		5		4			6										8	10	9		
A1	Transmission noise in "D", "2", "1" and "R" ranges.	1				2							3							4						5	6
A2	Failure to change from "3rd" to "2nd" when changing level into "2" range.		1			2		4		3							5						6				
	Gear change from "2nd" to "3rd" in "2" range.		1			2		3															4				
A3	Engine brake does not operate in "1" range.		1			2		4		3							5						6				
	Gear change from "1st" to "2nd" in "1" range.		1			2		3															4				
A4	Does not change from "2nd" to "1st" in "1" range.	1	2					4	5	3							7	6					8				
A5	Large shock changing from "2nd" to "1st" in "1" range.				1			4		3		2					5										
	Transaxle overheats.	1				2		5		4		3		6	9	11	12	13	10		16		14		7	15	8
	Oil shoots out during operation. White smoke emitted from exhaust pipe during operation.	1			2		4	6		3		5		6	9	11	12	13	10		16		14		7	15	8
	Offensive smell at oil charging pipe.	1						2					3	6	8	9	10	7		13		11		4	12	15	
A6	Torque converter is not locked up.					3		1	2				15										16		14		
A7	Lock-up piston slip.					1							12										14		3		
	Lock-up point is extremely high or low.							1	2														13				
	Engine is stopped at R.D. 2 and 1 ranges.							1															12		13		
A8	Torque converter lock-up pressure is not normal.				1		2	3					14												5		
	Transaxle shifts to overdrive even if O.D. control switch is turned to "OFF".											1											2				
	Lamp inside O.D. control switch does not glow even if transaxle is shifted to O.D.											2	1														

AUTOMATIC TRANSMISSION SERVICE GROUP



Technical Service Information

Road Testing (Cont'd)

VEHICLE SPEED AND LINE PRESSURE WHEN SHIFTING GEARS

This check should be carried out when oil temperature is between 43 to 57°C (109 to 135°F).

Throttle position	Gearshift	Vehicle speed km/h (MPH)
Full throttle	D ₁ → D ₂ , 2 ₁ → 2 ₂	52 (32)
	D ₂ → D ₃	107 (66)
	D ₃ → D ₄	-
	D ₄ → D ₅	-
	D ₃ → D ₂	93 (58)
	D ₂ → D ₁ , 2 ₂ → 2 ₁	36 (22)

SHIFT SCHEDULE

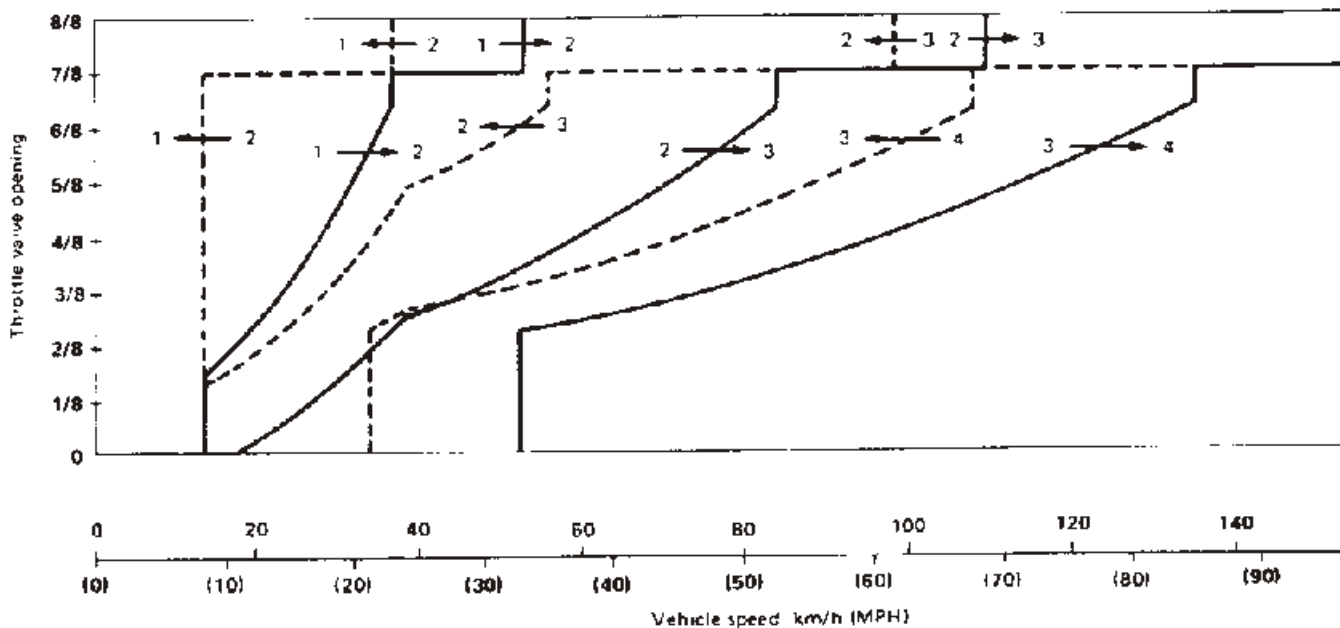

AUTOMATIC TRANSMISSION SERVICE GROUP

Pressure Testing

High clutch pressure
Line pressure



Reverse clutch pressure

Governor pressure

Lock-up pressure



Low clutch pressure

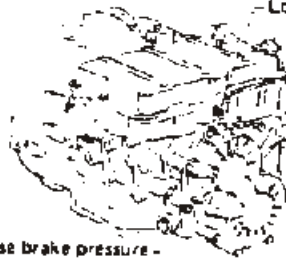

Low & reverse brake pressure

LINE PRESSURE

1. Install pressure gauge to line pressure port. Locate the gauge so it can be seen by driver.
2. Warm up engine until engine oil and A.T.F. reach operating temperatures.

A.T.F. temperature:

43 - 57°C (109 - 135°F)

3. Measure line pressure at idle and at stall point while depressing brake pedal fully.

At idling

Range	Line pressure kPa (kg/cm ² , psi)
R	367.8 - 436.4 (3.75 - 4.45, 53.3 - 63.3)
D	
2	
1	

At stall test

- Do not perform tests for more than five seconds at any shift range.
- Do not proceed to next "range" test immediately after one "range" test is done. Wait until oil temperature decreases.

Range	Line pressure kPa (kg/cm ² , psi)
R	1,206 - 1,363 (12.3 - 13.9, 175 - 198)
D	
2	
1	

Judgment by line pressure

- 1) When line pressure while idling is low at all positions ("D", "2", "1", "R" and "P"), the problem may be due to:
 - Wear on interior of oil pump
 - Oil leakage at or around oil pump, control valve body, transmission case or governor
 - Sticking pressure regulator valve
 - Sticking pressure modifier valve
- 2) When line pressure while idling is low at a particular position, the problem may be due to the following:
 - If oil leaks at or around forward clutch (rear) or governor, line pressure is low in "D", "2" or "1" range but is normal in "R" range.
 - If oil leaks at or around low and reverse brake circuit, line pressure becomes low in "R" or "P" range but is normal in "D", "2" or "1" range.
- 3) When line pressure is high while idling, pressure regulator valve may have stuck.

If line pressure does not rise, first check to make sure that throttle wire is connected properly.



Pressure Testing (Cont'd)

LOCK-UP TEST

Install pressure gauge to port. Shift selector lever in "D" range.

Condition	Torque converter lock-up pressure kPa (kg/cm ² , psi)
Lock-up "ON"	Less than 49 (0.5, 7)
Lock-up "OFF"	More than 196 (2, 28)

If lock-up pressure is not within specifications, refer to Trouble-shooting chart (A6).

Stall Testing

The stall test is an effective method of testing clutch and band holding ability, torque converter one-way clutch operation, and engine performance. A stall test should only be performed as a last resort because of the high fluid temperature it generates and the excessive load it places on the engine and transaxle.

CAUTION:

- Transaxle and engine fluid levels should always be checked and fluid added as needed.
- Run engine at 1,200 rpm to attain proper warm-up.
- During test, never hold throttle wide-open for more than 5 seconds.
- Do not test more than two gear ranges without driving vehicle to cool off engine and transaxle.

STALL TEST PROCEDURE

- Set parking brake and block wheels.

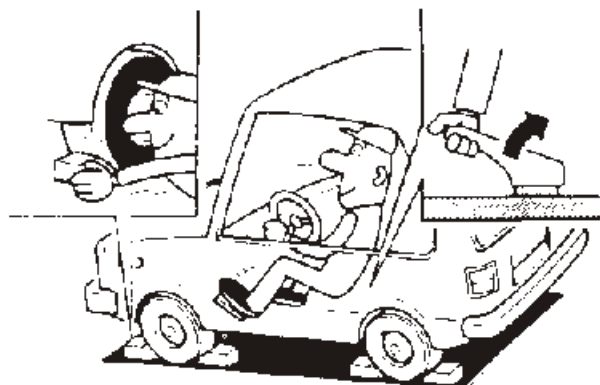

SAT597

- Install a tachometer where it can be seen by driver during test.
- Start engine and place selector lever in "D" range.
- Apply foot brake and accelerate to wide-open throttle.
- Quickly note the engine stall speed and immediately release throttle.

Stall revolution:

2,000 - 2,300 rpm

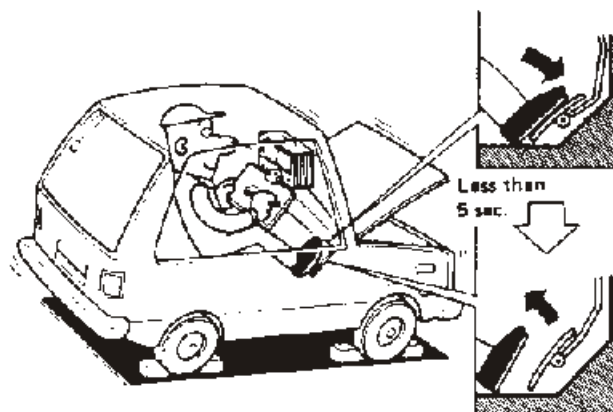

SAT598

- Shift selector lever to "N".
- Cool off transaxle fluid.
- Perform stall tests in the same manner as in steps 3 through 7 with selector lever in "1" and "R", respectively.

Stall Testing (Cont'd)

STALL TEST ANALYSIS

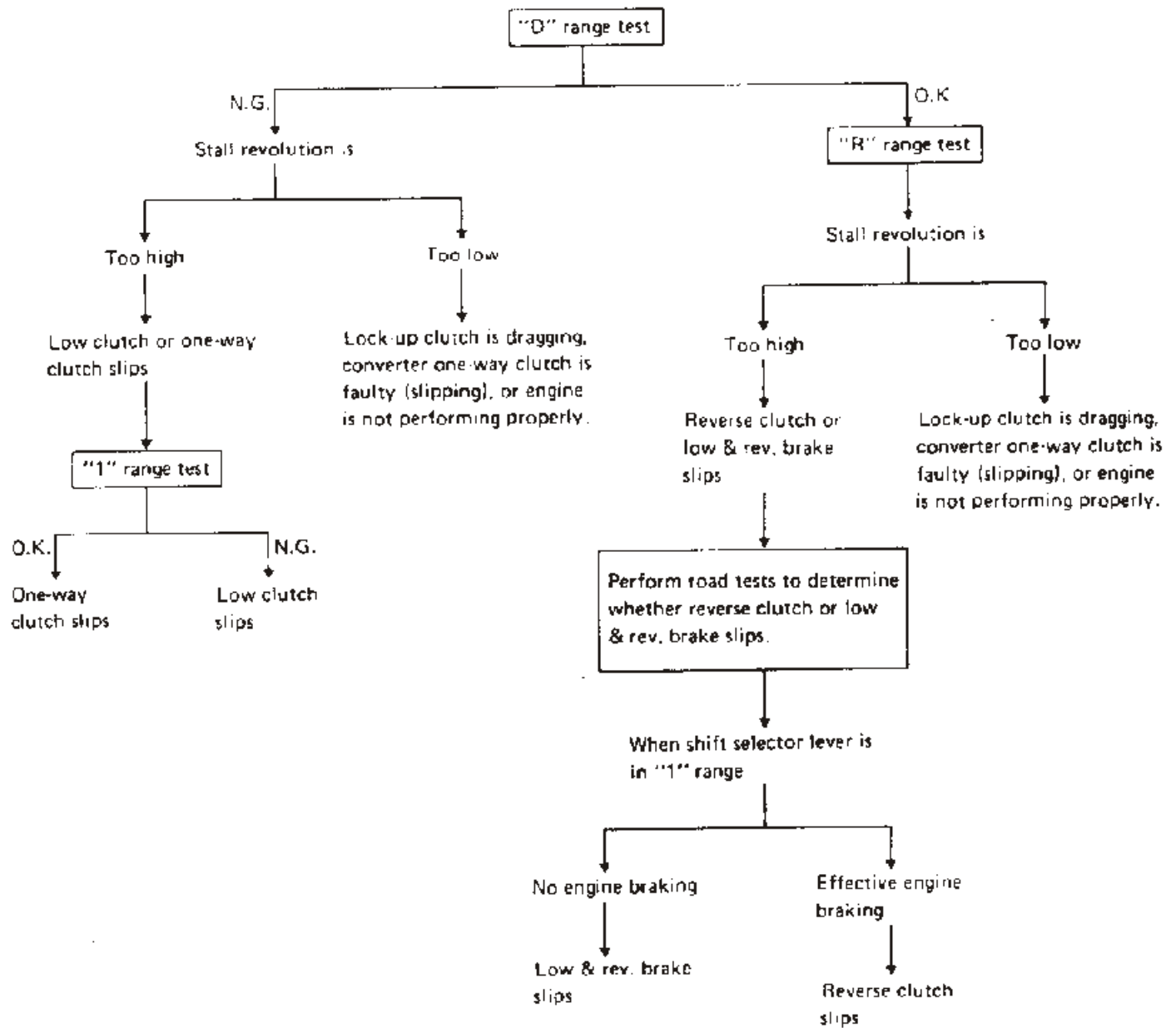

ProCarManuals.com

If converter one-way clutch is frozen, vehicle will have poor high speed performance. If converter one-way clutch is slipping, vehicle will be sluggish up to 50 or 60 km/h (30 or 40 MPH).

TROUBLE-SHOOTING AND DIAGNOSES — Electrical System

Schematic

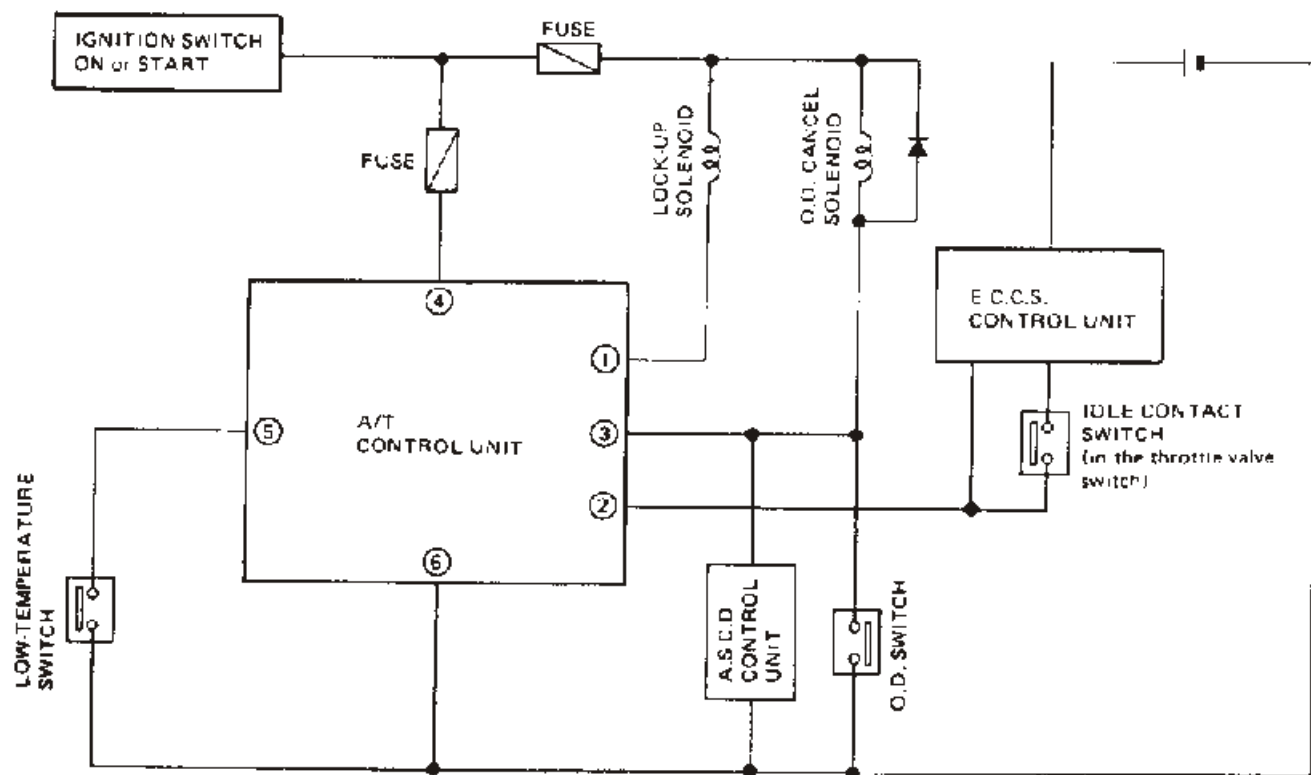

SAT195A

Wiring Diagram

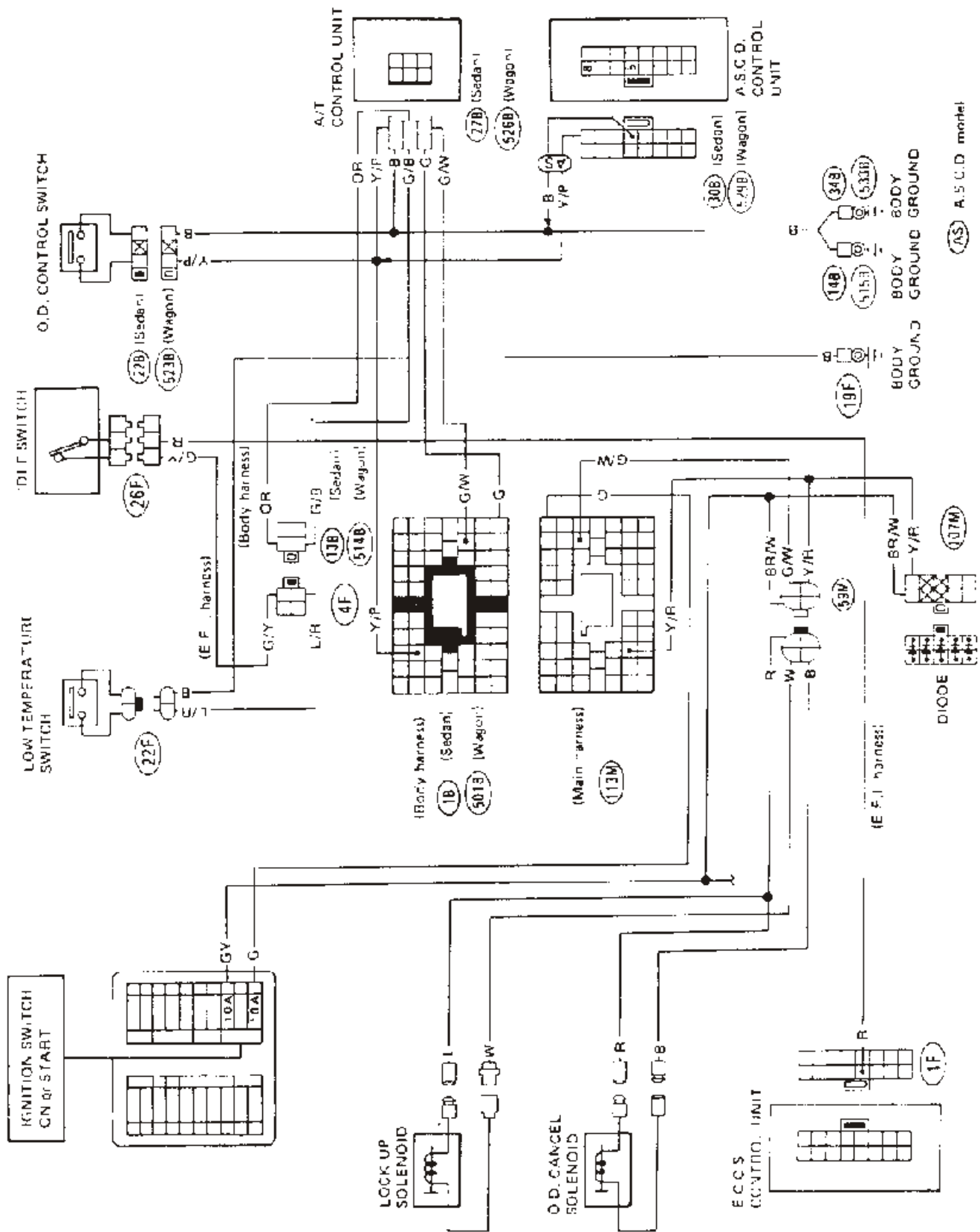

Inspection of A/T Control Unit

LOCATION OF A/T CONTROL UNIT

A/T control unit is located under driver's seat.

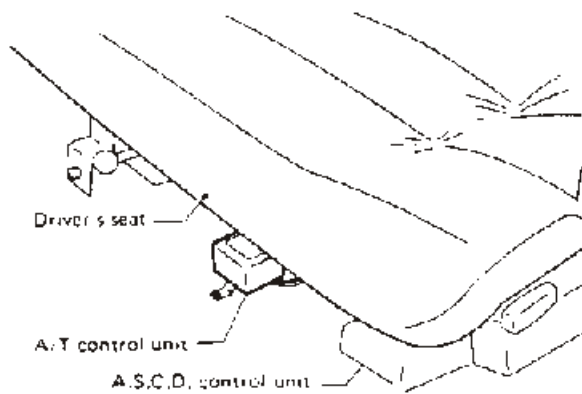

Check voltage between No. 6 terminal (ground) and each terminal in the following table.

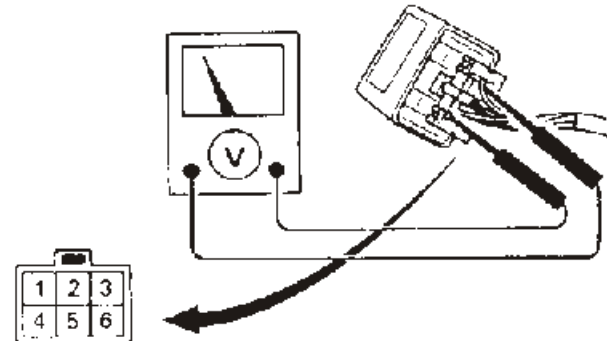

Check from harness side.

INSPECTION ITEM (Ignition key must be "ON")

Terminal No.	Checking input/output signal	Checking method	Judgement standard
1.	Lock-up control signal (G/W)	Connect tester to terminals No. 1 and No. 6. Measure in two situations as shown below. I. Disconnect connector for Low temp. switch.*1	I. • Less than 0.5V when accelerator pedal is not depressed. • more than 10V when accelerator pedal is depressed.
		II. Jump terminals of harness connector with a lead wire.*2	II. • Less than 0.5V when accelerator pedal is depressed.
2.	Idle switch signal (Orange)	Connect tester to terminals No. 2 and No. 6. Measure while operating accelerator pedal.	• 12V when accelerator pedal is not depressed. • Less than 0.5V when accelerator pedal is depressed.
3.	O.D. cancel signal (Y/P)	Connect tester to terminals No. 3 and No. 6. Measure in two situations, as shown below. I. Disconnect for Low temp. switch.*1	I. • Less than 0.5V when O.D. control switch is turned OFF. • More than 10V when O.D. control switch is turned ON.
		II. Jump terminals of harness connector with a lead wire.*2	II. • Less than 0.5V when O.D. control switch is turned ON.
4.	Power source (G)	Make ground connections. (Connect tester to terminals No. 4 and No. 6)	More than 10V at all times while ignition switch is turned ON.
5.	Low temperature switch (G/B)	Refer to AT-81	
6.	Ground (E)	Connect tester to terminal 6 and Body.	Check continuity

— Inspection of A/T Control Unit (Cont'd)

- *1 Disconnect connector for low temperature switch.

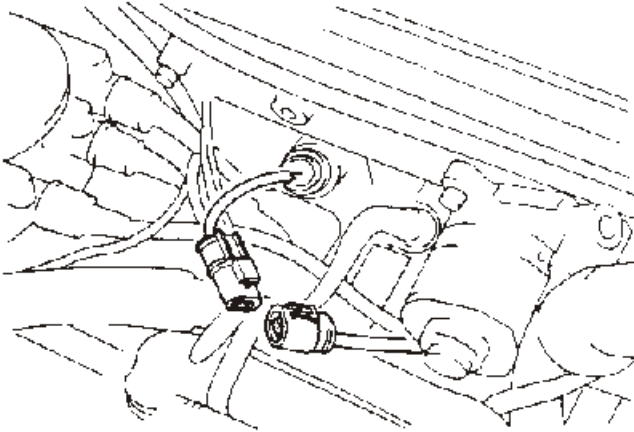

- *2 Jump terminals of harness connector with a lead wire.

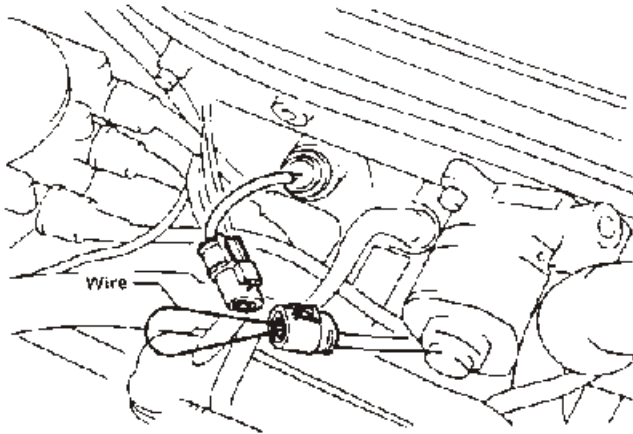

Inspection of O.D. Control

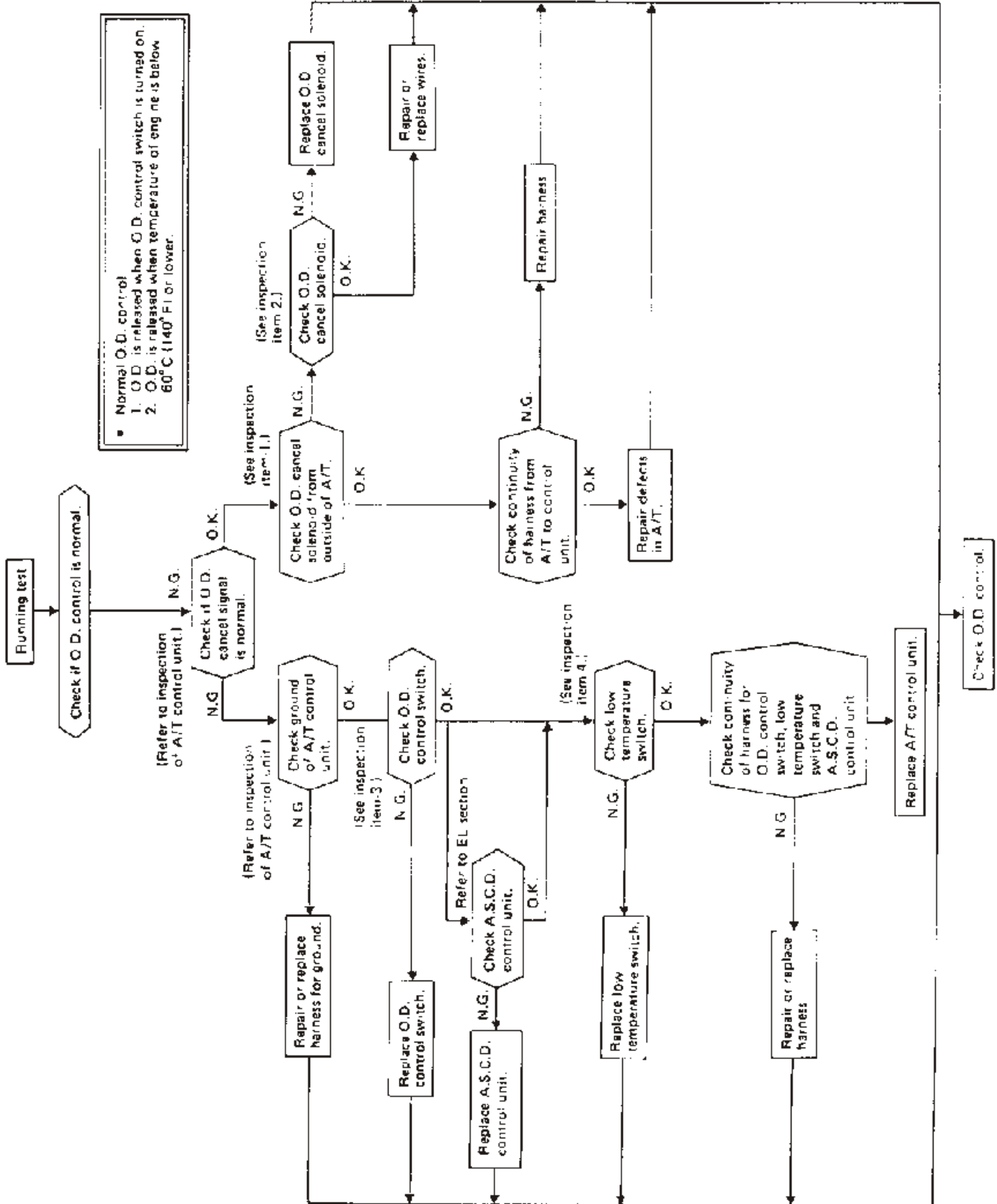

Inspection of O.D. Control (Cont'd)

INSPECTION ITEM-1

O.D. cancel solenoid (Check from outside of A/T.)
 Confirm that clicking sound is heard when power is applied.

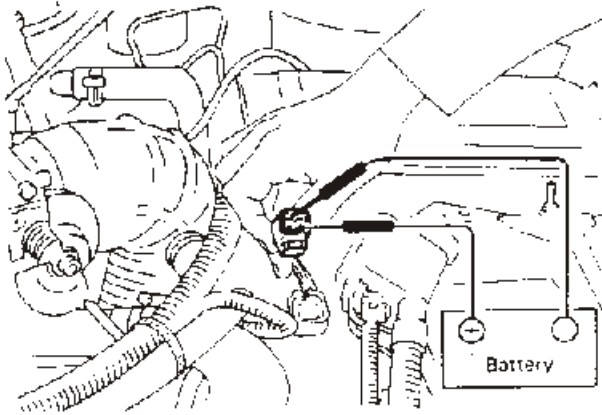

INSPECTION ITEM-2

O.D. cancel solenoid
 Remove the control valve cover and then confirm that clicking sound is heard when power is applied as shown below.

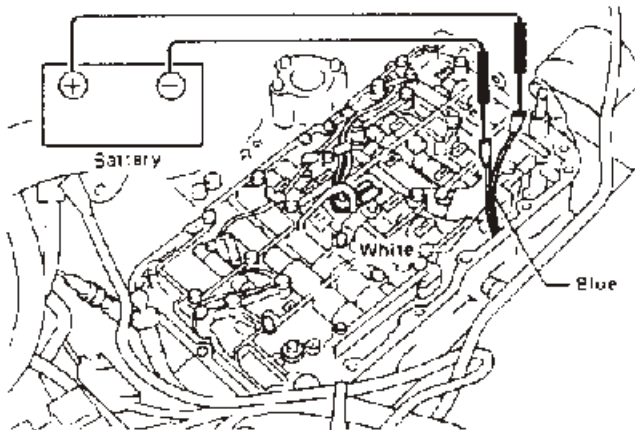

INSPECTION ITEM-3

O.D. control switch

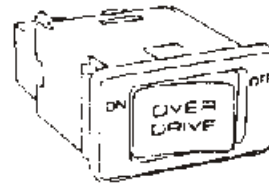

	ON	OFF
1		○
2		○

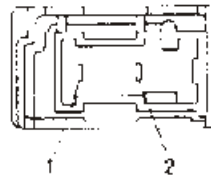

INSPECTION ITEM-4

Low temperature switch

Check for continuity when engine is cold [47°C (117°F) or lower] and for zero continuity when engine is hot [60°C (140°F) or higher].

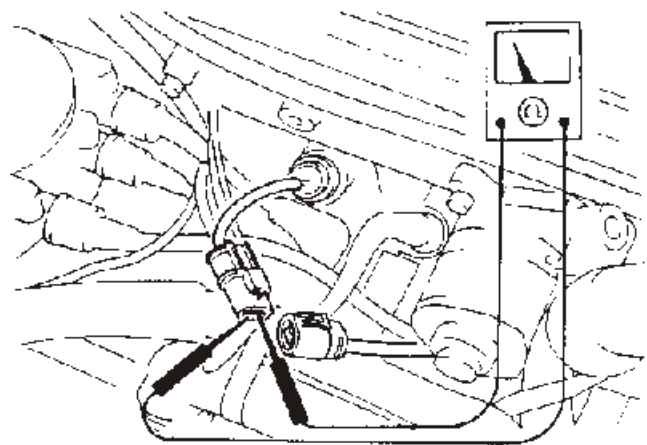

Inspection of Lock-up Control

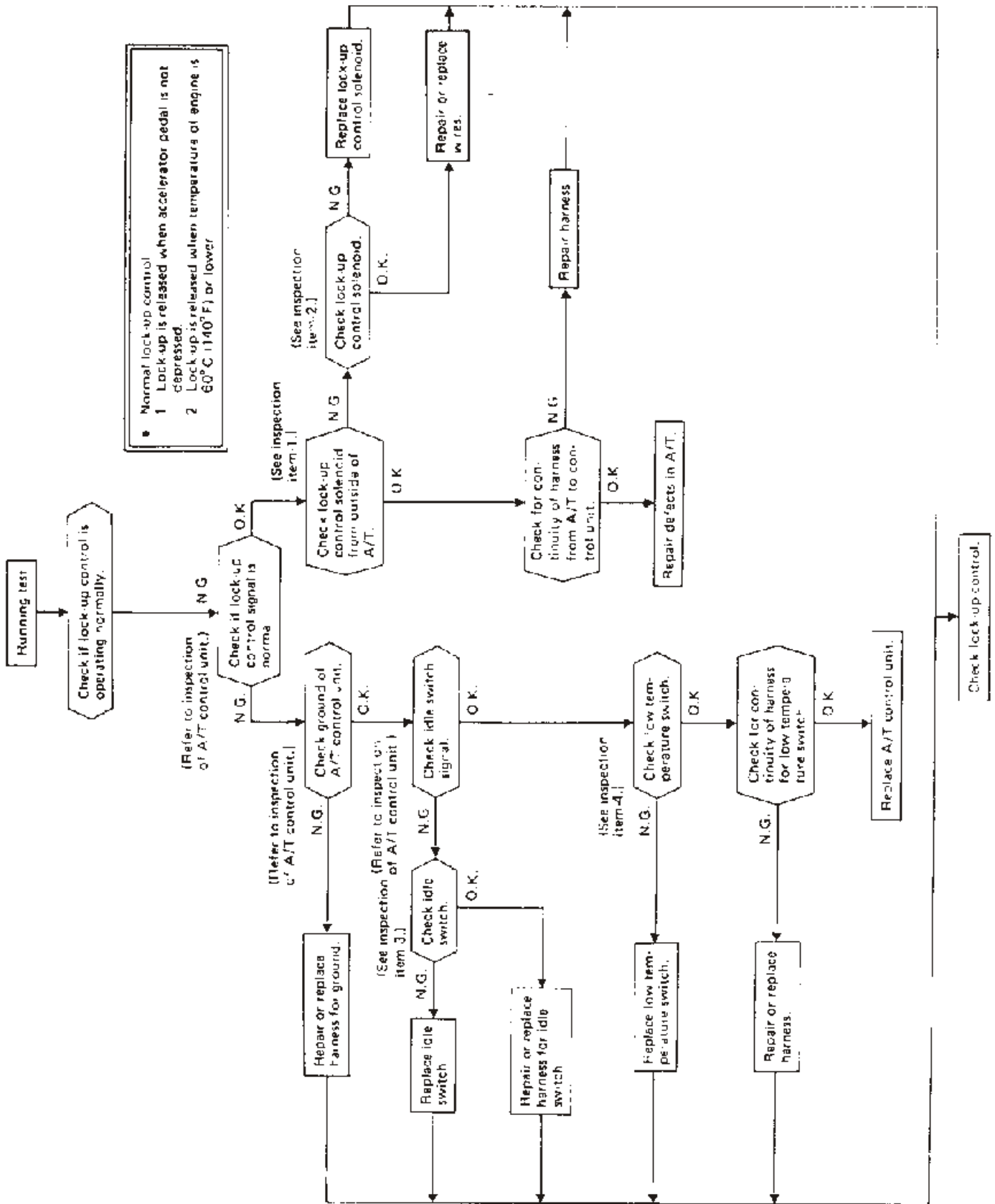

AUTOMATIC TRANSMISSION SERVICE GROUP

Inspection of Lock-up Control (Cont'd)

INSPECTION ITEM-1

Lock-up control solenoid
(Check from outside of A/T.)

Confirm that clicking sound is heard when power is applied as shown below.

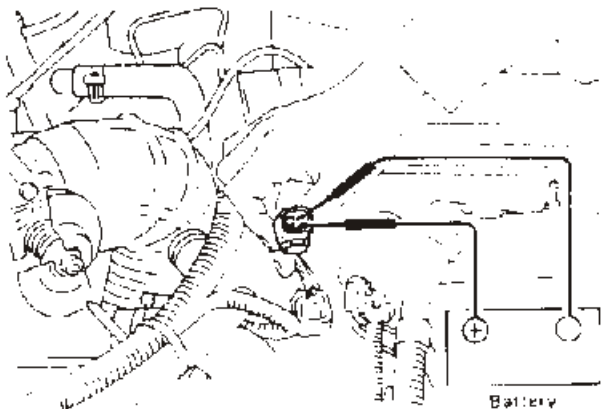

INSPECTION ITEM-2

Lock-up control solenoid

Remove the control valve cover and then confirm that clicking sound is heard when power is applied as shown below.

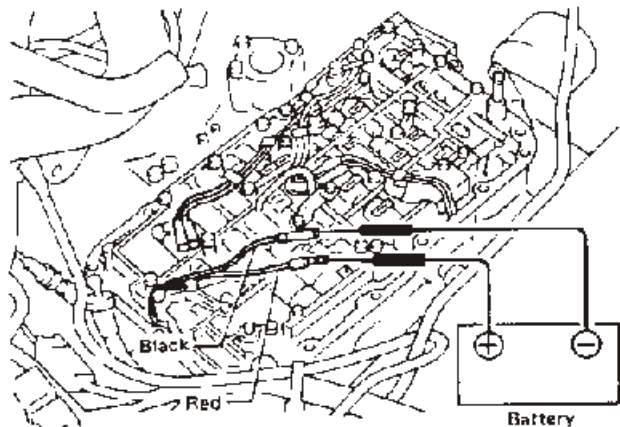

INSPECTION ITEM-3

Idle switch

Check for continuity when throttle valve is closed.

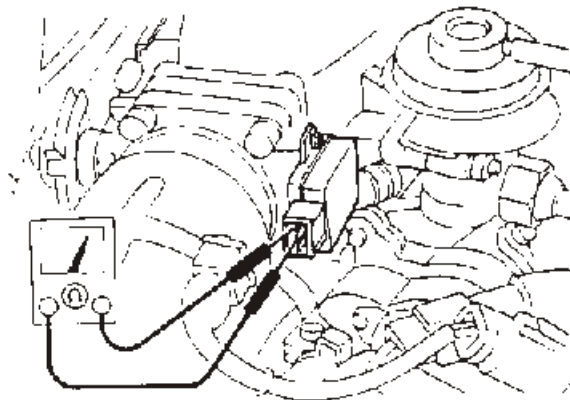

INSPECTION ITEM-4

Low temperature switch

Check for continuity when engine is cold [47°C (117°F) or lower] and for zero continuity when engine is hot [60°C (140°F) or higher].

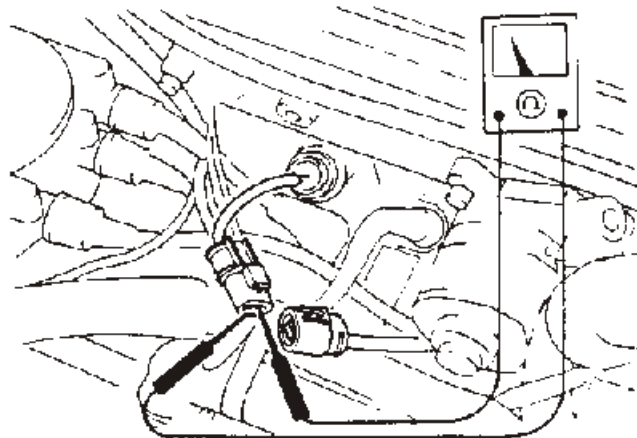



SERVICE DATA AND SPECIFICATIONS (S.D.S.)

General Specifications (RL4F02A)

Applied model	VG30E
Automatic transaxle model	RL4F02A
Automatic transaxle assembly Model code number	21X22
Transaxle gear ratio	
1st	2.785
2nd	1.545
3rd	1.000
4th	0.694
Reverse	2.272
Final drive	3.430
Recommended oil	Automatic transmission fluid "Dexron" type
Oil capacity	1 (US qt., Imp qt) 2.3 (7-3/4, 6-3/8)

Specifications and Adjustment for RL4F02A

High clutch	
Number of drive plates	4
Number of driven plates	4
Clearance mm (in)	
Standard	1.8 - 2.2 (0.071 - 0.087)
Allowable limit	3.0 (0.118)
Drive plate thickness mm (in)	
Standard	1.6 (0.039)
Allowable limit	1.4 (0.055)
Thickness of retaining plate	Thickness mm (in) Part number
	3.8 (0.142) 31567-21X00
	3.8 (0.150) 31567-21X01
	4.0 (0.157) 31567-21X02
	4.2 (0.165) 31567-21X03
	4.4 (0.173) 31567-21X04
	4.6 (0.181) 31567-21X05
	4.8 (0.189) 31567-21X06
	5.0 (0.197) 31567-21X10

Low clutch	
Number of drive plates	6
Number of driven plates	7
Clearance mm (in)	
Standard	0.5 - 0.8 (0.020 - 0.031)
Allowable limit	2.0 (0.079)
Drive plate thickness mm (in)	
Standard	2.0 (0.079)
Allowable limit	1.8 (0.071)
Thickness of retaining plate	Thickness mm (in) Part number
	3.2 (0.126) 31597-21X10
	3.4 (0.134) 31597-21X11
	3.6 (0.142) 31597-21X12
	3.8 (0.150) 31597-21X13
	4.0 (0.157) 31597-21X14
	4.2 (0.165) 31597-21X15
Reverse clutch	
Number of drive plates	2
Number of driven plates	2
Clearance mm (in)	
Standard	0.5 - 0.8 (0.020 - 0.031)
Allowable limit	1.2 (0.047)
Drive plate thickness mm (in)	
Standard	2.0 (0.079)
Allowable limit	1.8 (0.071)
Thickness of retaining plate	Thickness mm (in) Part number
	4.6 (0.181) 31537-21X10
	4.8 (0.189) 31537-21X11
	5.0 (0.197) 31537-21X12
	5.2 (0.205) 31537-21X13
	5.4 (0.213) 31537-21X14



SERVICE DATA AND SPECIFICATIONS (S.D.S.)

Specifications and Adjustment for RL4F02A (Cont'd)

Low & reverse brake																					
Number of drive plates	7																				
Number of driven plates	7																				
Clearance mm (in)																					
Standard	2.2 - 2.6 (0.087 - 0.102)																				
Allowable limit	4.0 (0.157)																				
Drive plate thickness mm (in)																					
Standard	2.0 (0.079)																				
Allowable limit	1.8 (0.071)																				
Thickness of retaining plate	<table border="1"> <thead> <tr> <th>Thickness mm (in)</th> <th>Part number</th> </tr> </thead> <tbody> <tr><td>3.4 (0.134)</td><td>31667-21X00</td></tr> <tr><td>3.6 (0.142)</td><td>31667-21X01</td></tr> <tr><td>3.8 (0.150)</td><td>31667-21X02</td></tr> <tr><td>4.0 (0.157)</td><td>31667-21X03</td></tr> <tr><td>4.2 (0.165)</td><td>31667-21X04</td></tr> <tr><td>4.4 (0.173)</td><td>31667-21X05</td></tr> <tr><td>4.6 (0.181)</td><td>31667-21X06</td></tr> <tr><td>4.8 (0.189)</td><td>31667-21X07</td></tr> <tr><td>5.0 (0.197)</td><td>31667-21X08</td></tr> </tbody> </table>	Thickness mm (in)	Part number	3.4 (0.134)	31667-21X00	3.6 (0.142)	31667-21X01	3.8 (0.150)	31667-21X02	4.0 (0.157)	31667-21X03	4.2 (0.165)	31667-21X04	4.4 (0.173)	31667-21X05	4.6 (0.181)	31667-21X06	4.8 (0.189)	31667-21X07	5.0 (0.197)	31667-21X08
Thickness mm (in)	Part number																				
3.4 (0.134)	31667-21X00																				
3.6 (0.142)	31667-21X01																				
3.8 (0.150)	31667-21X02																				
4.0 (0.157)	31667-21X03																				
4.2 (0.165)	31667-21X04																				
4.4 (0.173)	31667-21X05																				
4.6 (0.181)	31667-21X06																				
4.8 (0.189)	31667-21X07																				
5.0 (0.197)	31667-21X08																				
Brake band piston size mm (in)																					
Big dia.	75 (2.95)																				
Small dia.	35 (1.38)																				
Planetary carrier mm (in)																					
Clearance between piston washer and planetary carrier																					
Standard	0.15 - 0.70 (0.0059 - 0.0276)																				
Allowable limit	0.80 (0.0315)																				
Oil pump clearance mm (in)																					
Cam ring - oil pump cover																					
Standard	0.010 - 0.024 (0.0004 - 0.0009)																				
Allowable limit	0.034 (0.0013)																				
Rotor - oil pump cover																					
Standard	0.010 - 0.024 (0.0004 - 0.0009)																				
Allowable limit	0.034 (0.0013)																				
Vane - oil pump cover																					
Standard	0.010 - 0.024 (0.0004 - 0.0009)																				
Allowable limit	0.034 (0.0013)																				

CLUTCH PACK END PLAY

0.4 - 0.8 mm (0.016 - 0.031 in)

CLUTCH PACK THRUST WASHER

Thickness mm (in)	Part number
0.7 (0.028)	31528-21X00
0.9 (0.035)	31528-21X01
1.1 (0.043)	31528-21X02
1.3 (0.051)	31528-21X03
1.5 (0.059)	31528-21X04
1.7 (0.067)	31528-21X05
1.9 (0.075)	31528-21X06

TOTAL END PLAY

0.25 - 0.55 mm (0.0098 - 0.0217 in)

**OIL PUMP HOUSING BEARING RACE
(For total end play)**

Thickness mm (in)	Part number
0.8 (0.031)	31429-21X00
1.0 (0.039)	31429-21X01
1.2 (0.047)	31429-21X02
1.4 (0.055)	31429-21X03
1.6 (0.063)	31429-21X04
1.8 (0.071)	31429-21X05
2.0 (0.079)	31429-21X06

Diff. side bearing preload adjusting shim

Thickness mm (in)	Part number
0.44 (0.0173)	38453-21X00
0.48 (0.0189)	38453-21X01
0.52 (0.0205)	38453-21X02
0.56 (0.0220)	38453-21X03
0.60 (0.0236)	38453-21X04
0.64 (0.0252)	38453-21X05
0.68 (0.0268)	38453-21X06
0.72 (0.0283)	38453-21X07
0.76 (0.0299)	38453-21X08
0.80 (0.0315)	38453-21X09
0.84 (0.0331)	38453-21X10
0.88 (0.0346)	38453-21X11
0.92 (0.0362)	38453-21X12

Specifications and Adjustment for RL4F02A (Cont'd)

PARKING PAWL

Clearance "A":

0.27 - 0.61 mm (0.0106 - 0.0240 in)

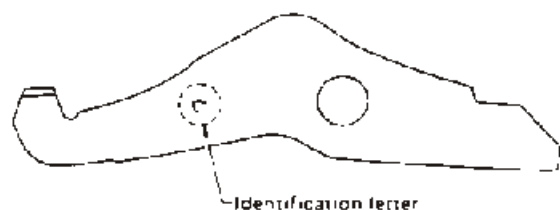

Identification letter	Part number
D	31989-21X00
E	31989-21X01
F	31989-21X02

STALL REVOLUTION

rpm	2,000 - 2,300
-----	---------------

TIGHTENING TORQUE

Unit	N·m	kg·m	ft·lb
Drive plate to torque converter	39 - 49	4.0 - 5.0	29 - 36
Converter housing to engine	39 - 49	4.0 - 5.0	29 - 36
Engine to converter housing	30 - 40	3.1 - 4.1	22 - 30
Gusset to converter housing	16 - 21*1 6.3 - 8.3*2	1.6 - 2.1*1 0.64 - 0.85*2	12 - 15*1 24.5 - 6.1*2
Transmission case to converter housing	16 - 21	1.6 - 2.1	12 - 15
Transmission case to side cover	16 - 21	1.6 - 2.1	12 - 15
Transmission case to valve cover	5 - 7	0.5 - 0.7	3.6 - 5.1
Transmission case to bearing retainer	16 - 21	1.6 - 2.1	12 - 15
Oil pump cover to converter housing	16 - 21	1.6 - 2.1	12 - 15

Unit	N·m	kg·m	ft·lb
Control valve body to transmission case	7 - 9 3.7 - 5.0	0.7 - 0.9 0.38 - 0.51	5.1 - 6.5 2.7 - 3.7
Governor cap to converter housing	5 - 7	0.5 - 0.7	3.6 - 5.1
Speedometer case to converter housing	5.3 - 8.3	0.54 - 0.85	4.6 - 6.1
Inhibitor switch to transmission case	2.0 - 2.5	0.20 - 0.26	1.4 - 1.9
Throttle lever lock nut	9.1 - 11.8	0.93 - 1.20	6.7 - 8.7
Actuator support to transmission case	16 - 21	1.6 - 2.1	12 - 15
Band piston stem (when adjusting band brake)	4 - 6*3	0.4 - 0.6*3	2.9 - 4.3*3
Lower valve body to upper valve body	3.4 - 4.4	0.35 - 0.45	2.5 - 3.3
Final drive bolt	74 - 88	7.5 - 9.0	54 - 65
Governor valve body to governor shaft	5 - 7	0.5 - 0.7	3.6 - 5.1
Governor shaft securing bolt	20 - 26	2.0 - 2.7	14 - 20
Manual shaft lock nut	31 - 42	3.2 - 4.3	23 - 31
Oil strainer to converter housing	6.3 - 8.3	0.64 - 0.85	4.6 - 6.1
Control cylinder to transmission case	6.0 - 8.3	0.64 - 0.85	4.6 - 6.1
Test plug (oil pressure inspection hole)	5 - 10*4 10 - 15*5	0.5 - 1.0*4 1.0 - 1.5*5	3.6 - 7.2*4 7 - 11*5
Piston stem lock nut	31 - 42	3.2 - 4.3	23 - 31
Detent spring to transmission case	3.7 - 5.0	0.38 - 0.51	2.7 - 3.7
Drain plug to transmission case	15 - 20	1.5 - 2.0	11 - 14
Oil cooler pipe to transmission case	25 - 49	3.0 - 5.0	22 - 36

- *1 M10 bolt
- *2 M6 bolt
- *3 Turn back 5 1/4 turns after tightening
- *4 Small size
- *5 Large size



SERVICE DATA AND SPECIFICATIONS (S.D.S.)

Specifications and Adjustment for RL4F02A (Cont'd)

Output shaft preload adjusting shim

Thickness mm (in)	Part number
0.12 (0.0047)	31499-21X00
0.16 (0.0063)	31499-21X01
0.20 (0.0079)	31499-21X02
0.24 (0.0094)	31499-21X03
0.28 (0.0110)	31499-21X04
0.32 (0.0126)	31499-21X05
0.36 (0.0142)	31499-21X06
0.40 (0.0157)	31499-21X07
0.44 (0.0173)	31499-21X08
0.48 (0.0189)	31499-21X09
0.52 (0.0205)	31499-21X10
0.56 (0.0220)	31499-21X11
0.60 (0.0236)	31499-21X12
0.64 (0.0252)	31499-21X13
0.68 (0.0268)	31499-21X14
0.72 (0.0283)	31499-21X15
0.76 (0.0299)	31499-21X16
0.80 (0.0315)	31499-21X17
0.84 (0.0331)	31499-21X18
0.88 (0.0346)	31499-21X19
0.92 (0.0362)	31499-21X20
1.44 (0.0567)	31499-21X21
1.96 (0.0772)	31499-21X22

Idler gear preload adjusting shim

Thickness mm (in)	Part number
0.36 (0.0142)	31499-21X06
0.40 (0.0157)	31499-21X07
0.44 (0.0173)	31499-21X08
0.48 (0.0189)	31499-21X09
0.52 (0.0205)	31499-21X10
0.56 (0.0220)	31499-21X11
0.60 (0.0236)	31499-21X12
0.64 (0.0252)	31499-21X13
0.68 (0.0268)	31499-21X14
0.72 (0.0283)	31499-21X15
0.76 (0.0299)	31499-21X16
0.80 (0.0315)	31499-21X17
0.84 (0.0331)	31499-21X18
0.88 (0.0346)	31499-21X19
0.92 (0.0362)	31499-21X20
1.44 (0.0567)	31499-21X21
1.96 (0.0772)	31499-21X22

CLEARANCE BETWEEN SIDE GEAR AND DIFF. CASE WITH WASHER

0 - 0.2 mm (0 - 0.008 in)

SIDE GEAR THRUST WASHER

Thickness mm (in)	Part number
0.75 (0.0295)	38424-21X00
0.80 (0.0315)	38424-21X01
0.85 (0.0335)	38424-21X02
0.90 (0.0354)	38424-21X03

AUTOMATIC TRANSMISSION SERVICE GROUP

NISSAN RL4F02A FALLS OUT OF OVERDRIVE AT TIMES

- COMPLAINT:** TRANSAXLE UPSHIFTS OK, BUT DOWNSHIFTS 4-3 OR 4-2 AT HIGHWAY SPEEDS WHEN YOU LIFT YOUR FOOT OFF OF THE GAS PEDAL.
- CAUSE:** THE PROBLEM CAN BE EXCESSIVE END PLAY IN THE GOVERNOR SHAFT. THIS WILL CAUSE THE SHAFT TO MOVE UPWARD ON THE SPIRAL GEAR WHEN COASTING, AND BLOCK GOVERNOR FEED OIL.
- CORRECTION:** REMOVE THE BOLT AND PIN THAT HOLDS THE GOVERNOR SHAFT INTO THE CASE. INSPECT THE PIN FOR WEAR AND REPLACE IT IF NECESSARY. SEE FIGURE 1.

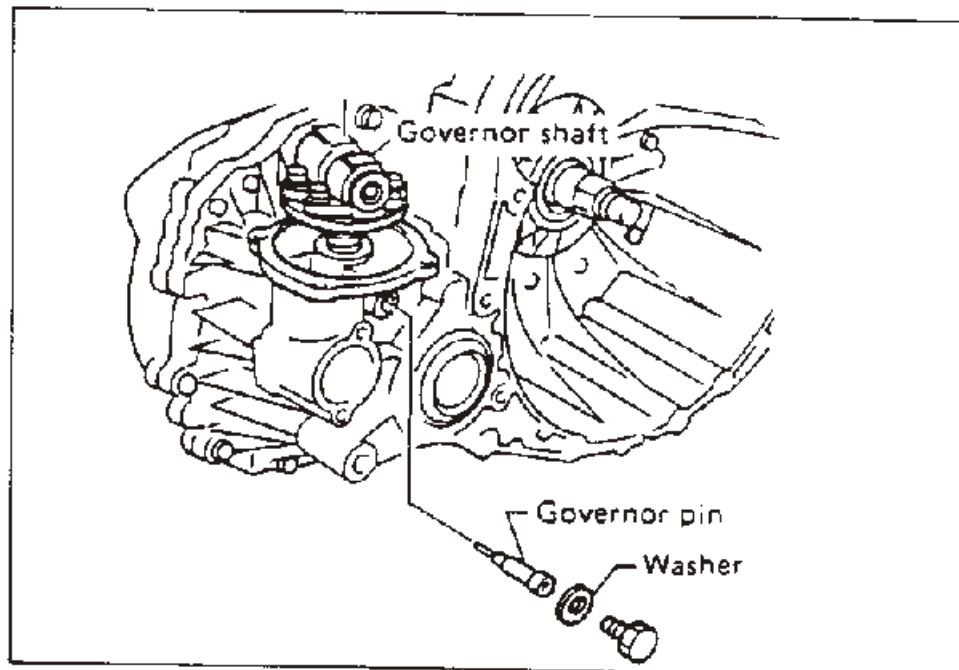

FIGURE 1.



RL4F02A AUTOMATIC TRANSAXLE LOCK-UP SHUDDER

APPLIED MODELS: 1985-1987 Maxima (U11)

SERVICE INFORMATION:

Some of the Applied Model vehicles equipped with the RL4F02A automatic transaxle may exhibit a noticeable vibration (shudder) when transaxle lock-up occurs. The shudder occurs mainly when the vehicle is in overdrive and when throttle position is 1/8 to 3/8 open. The shudder will either not occur, or will stop if throttle position is markedly increased.

If the above condition exists, use the following procedure to diagnose incident vehicles.

Refer to the appropriate Service Manual and check for proper throttle wire adjustment. Adjust as necessary. Road test again. If the "shudder" incident still exists, remove the transmission from the vehicle and perform the following inspections and repairs.

INSPECTION:

Inspect and correct the following items as necessary.

1. Inspect the input shaft O-ring. If the O-ring is damaged, replace it.

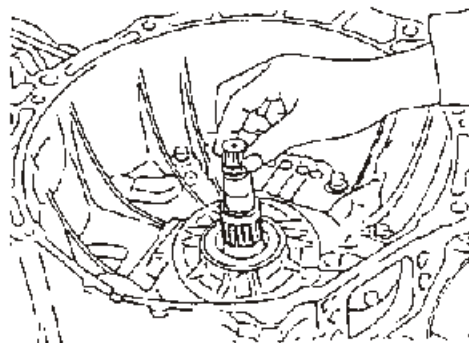

AUTOMATIC TRANSMISSION SERVICE GROUP

2. Differential lubrication tube. The tube should have an interference fit into the transmission case. If the tube is loose or broken, replace it with a new tube, (part number 31328-21X03).

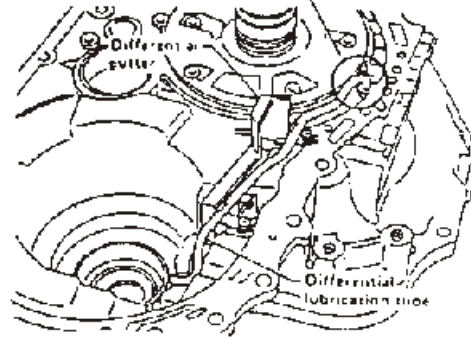
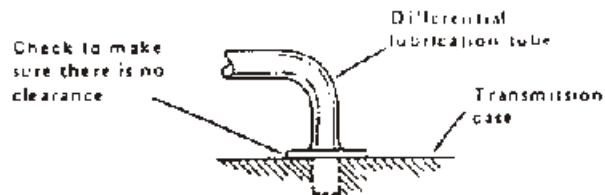

3. Check to make sure the lock up control sleeve is not seized in the control valve body. Also, check to make sure no other valves are seized in the valve body. Clean, lubricate and check all components in the control valve body as necessary.

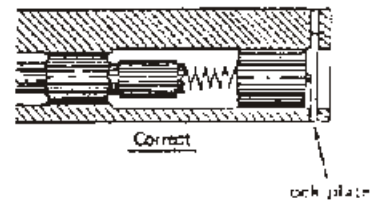
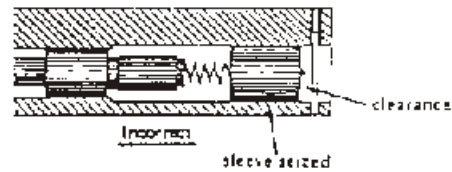

LOCK-UP CONTROL VALVE

4. Replace the 2-3 shift valve and the 4th speed out spring with new parts. (See chart on page 3/4.)



Technical Service Information

5. Check for any metal flakes or friction material in the transmission. Find the source of the material and replace the worn parts. If necessary, flush the unit and replace the automatic transmission fluid.
6. Make sure all of the control valve fixing bolts are torqued to specification.

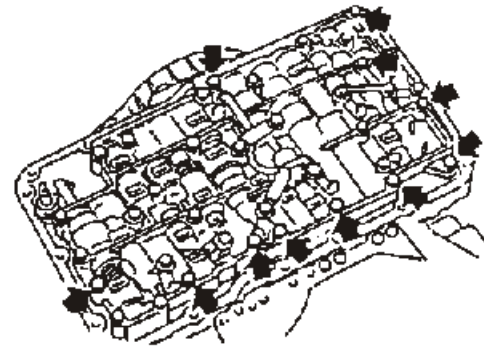

PARTS INFORMATION

PART NAME	PART NUMBER	
	NEW	FORMER
Differential Lubrication Tube	31328-21X03	31328-21X01
2-3 Shift Valve	31766-21X09	31766-21X07
4th Speed Cut Spring	31736-01X01	31742-21X06

AUTOMATIC TRANSMISSION SERVICE GROUP



NISSAN RL4F02A EARLY/HARSH UPSHIFTS

COMPLAINT: Some 1985-1986 Maxima vehicles with RL4F02A transaxles may exhibit early/harsh upshifts under light throttle openings and/or a clunk on a closed throttle 2-3 upshift.

CAUSE: The cause may be valve body and governor calibration.

CORRECTION: To improve this condition, a new governor assembly, and different valve body shift springs are available from OEM. Refer to parts information in Figure 4 for OEM part numbers.

Use the following procedure for installation;

1. Remove battery and bracket.
2. Remove air cleaner, air flow meter, air camper and solenoid valves as an assembly.
3. Remove Governor cap and gasket.
4. Install the new governor assembly (31860-24X04) on the governor shaft, and torque bolts (4) to 3.6-5.1 ft. lb. (See Figure 1).
5. Re-install governor cap and gasket.
6. Disconnect the control cable and throttle cable, remove the throttle lever (Figure 2) and remove the transaxle cover.
7. Disconnect the harness connector from the valve body, and remove ONLY the valve body bolts indicated in Figure 3.
8. Remove and replace the 6 springs that are numbered, as shown in Figure 3.
9. Re-install valve body and torque bolts to 5.1-6.5 ft. lb.

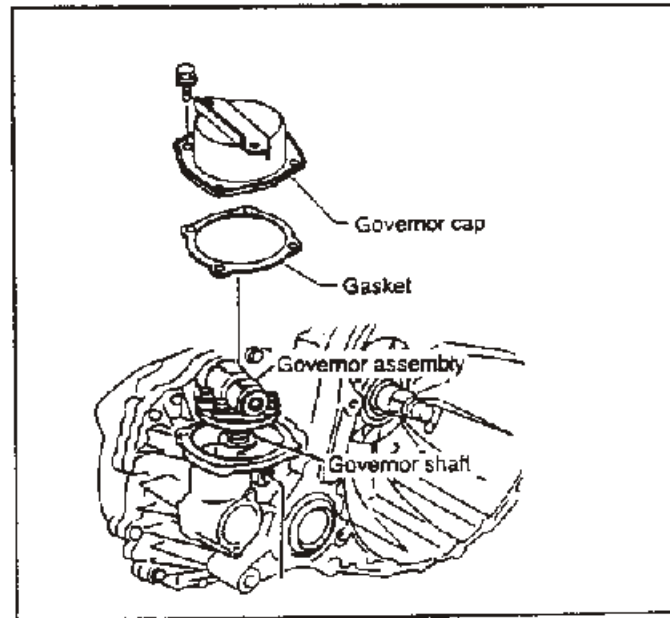

Figure 1

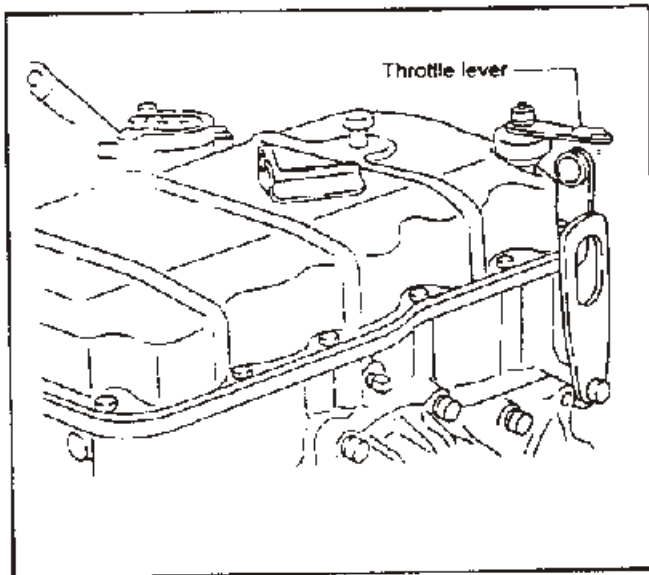

Figure 2

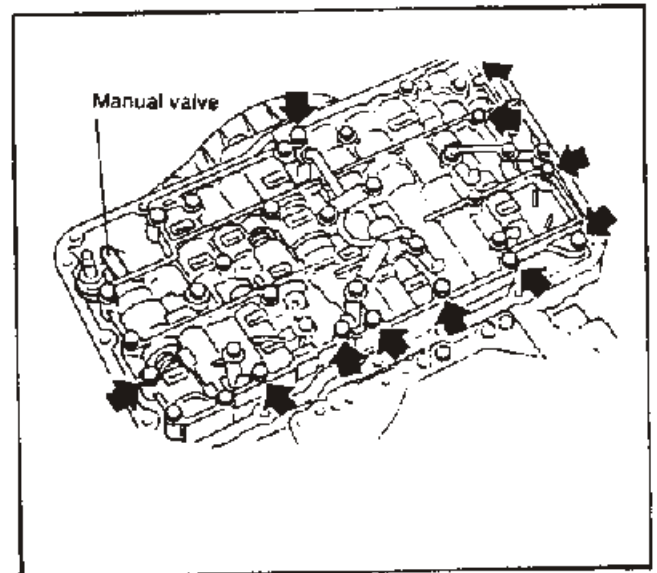

Figure 3

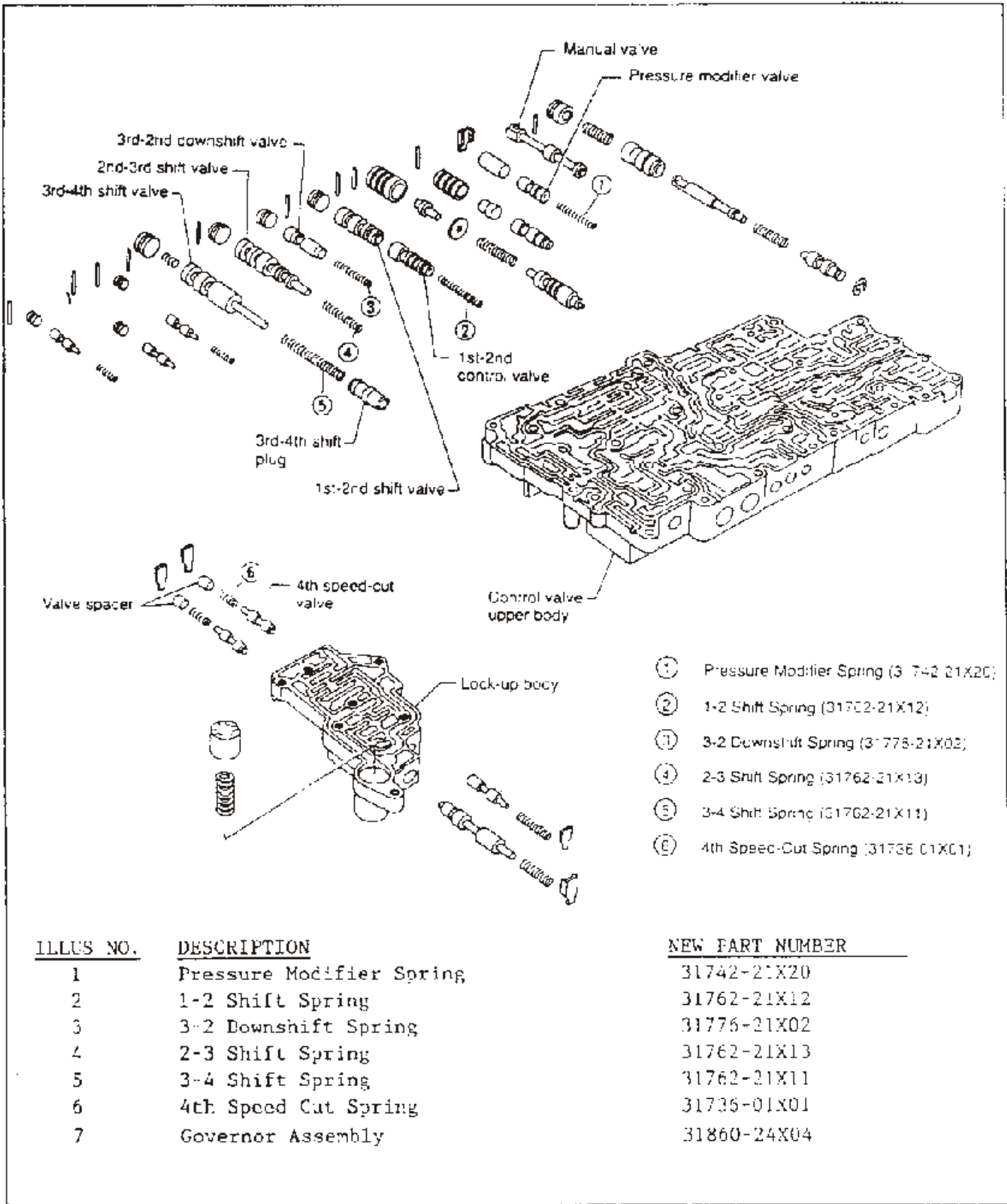

Figure 4