



**HONDA  
PX4B**

**INDEX**

<i>IDENTIFICATION.....</i>	1,40
<i>DESCRIPTION OF OPERATION.....</i>	3,46
<i>COMPONENT APPLICATION CHART.....</i>	4
<i>SOLENOID OPERATION CHART.....</i>	5
<i>ELECTRONIC COMPONENT LOCATION.....</i>	10,12,40
<i>ATSG HONDA BULLETIN INDEX.....</i>	12-14
<i>CODES.....</i>	40
<i>SOLENOID TEST.....</i>	40
<i>SPEED SENSOR TEST.....</i>	40
<i>PRESSURE PORT LOCATION.....</i>	41
<i>PRESSURE SPECIFICATIONS.....</i>	42
<i>DIAGNOSIS.....</i>	46
<i>SHIFT SPEED SPECIFICATION.....</i>	49
<i>STALL SPEED TEST.....</i>	50
<i>MAINTENANCE.....</i>	51
<i>DISASSEMBLY/ASSEMBLY.....</i>	58
<i>VALVE BODY.....</i>	65-73
<i>CHECK BALL LOCATIONS.....</i>	66-69
<i>SPRAG ROTATION.....</i>	78
<i>DIFFERENTIAL.....</i>	96-100
<i>THROTTLE PRESSURE / CABLE ADJUSTMENT.....</i>	101

**AUTOMATIC TRANSMISSION SERVICE GROUP  
18639 S.W. 107TH AVENUE  
MIAMI, FLORIDA 33157  
(305) 670-4161**

Copyright © ATSG 1999



## INTRODUCTION

*Updated  
January, 2004*

**PX4B - 1990 ACCORD  
APX4 - 1991/1992 ACCORD  
MPWA - 1991/1992 ACCORD ONLY  
MP1A - 1992 PRELUDE**

This manual covers only the Honda models listed above and sold in the U.S. The 1991/1992 Accord may have a APX4 or MPWA. The APX4 is built in the U.S. and the MPWA is built in Japan. The MPWA transaxle covered in this manual is for the Honda Accord *only*. The Acura Vigor has a transaxle with the same model designation, but is entirely different. This transaxle is transverse mounted, has four forward speeds with 4th gear being overdrive and is equipped with a converter clutch. The MP1A Transaxle Control Unit (TCU) uses a different strategy to allow the Prelude to apply the converter clutch in the D3 position. There are different gear ratios for different vehicle applications. Extra care should be used when interchanging parts and transaxles. This transaxle is designed to have engine braking in M1 and M2. Externally the PX4B, APX4, MPWA and MP1A, are visually very similar. The starter is mounted in the center of the bell housing near the top. Two pairs of solenoids are located on the bell housing to make a total of 4 solenoids. Two transaxle speed sensors are located in the end cover on opposite sides of each other. The vehicle speed sensor is located on top of the power steering speed sensor (hydraulic), above the speedometer gear. To accurately determine the model, check the transaxle identification tag.

*We wish to thank Honda  
for the information and illustrations  
that have made this booklet possible.*

No part of any ATSG publication may be reproduced, stored in any retrieval system or transmitted in any form or by any means, including but not limited to electronic, mechanical, photocopying, recording or otherwise, without *written* permission of Automatic Transmission Service Group. This includes all text illustrations, tables and charts.

*The information and part numbers contained in this booklet have  
been carefully compiled from industry sources known for their  
reliability, but ATSG does not guarantee its accuracy.*

**DALE ENGLAND**  
FIELD SERVICE CONSULTANT

**WAYNE COLONNA**  
TECHNICAL SUPERVISOR

**PETER LUBAN**  
TECHNICAL CONSULTANT

**JON GLATSTEIN**  
TECHNICAL CONSULTANT

**ROLAND ALVAREZ**  
TECHNICAL CONSULTANT

**GERALD CAMPBELL**  
TECHNICAL CONSULTANT

*Copyright © ATSG 2004*

**JIM DIAL**  
TECHNICAL CONSULTANT

**ED KRUSE**  
TECHNICAL CONSULTANT

**GREGORY LIPNICK**  
TECHNICAL CONSULTANT

**DAVID CHALKER**  
TECHNICAL CONSULTANT

**JERRY GOTT**  
TECHNICAL CONSULTANT

**MIKE SOUZA**  
TECHNICAL CONSULTANT

***AUTOMATIC TRANSMISSION SERVICE GROUP***  
**18639 SW 107TH AVENUE**  
**MIAMI, FLORIDA 33157**  
**(305) 670-4161**



# Technical Service Information

The Automatic Transmission is a combination of a 3-element torque converter and a triple-shaft electronically controlled automatic transmission which provides 4 speeds forward and 1 speed reverse. The entire unit is positioned in line with the engine.

## Torque Converter, Gears and Clutches

The torque converter consists of a pump, turbine and stator assembled in a single unit.

They are connected to the engine crankshaft so they turn together as a unit as the engine turns. Around the outside of the torque converter is a ring gear which meshes with the starter pinion when the engine is being started. The entire torque converter assembly serves as a flywheel while transmitting power to the transmission mainshaft.

The transmission has three parallel shafts: the mainshaft, the countershaft, and the secondary shaft. The mainshaft is in line with the engine crankshaft.

The mainshaft includes the clutches for 3rd and 4th, and gears for 3rd, 4th, Reverse and Idler (Reverse gear is integral with 4th gear).

The countershaft includes the 1st-hold clutch and gears for 2nd, 3rd, 4th, Reverse, 1st and Idler.

The secondary shaft includes 1st and 2nd clutches, and gears for 2nd, 1st and Idler.

The 4th and reverse gears can be locked to the countershaft at its center, providing 4th gear or Reverse, depending on which way the selector is moved.

The gears on the mainshaft are in constant mesh with those on the countershaft and the secondary shaft. When certain combinations of gears in the transmission are engaged by the clutches, power is transmitted from the mainshaft to the countershaft to provide **D<sub>4</sub>**, **D<sub>3</sub>**, **2**, **1** and **R**.

## Electronic Control

The electronic control system consists of an A/T control unit, sensors, and 4 solenoid valves. Shifting and lockup are electronically controlled for comfortable driving under all conditions.

The A/T control unit is located below the dashboard, behind the right side kick panel on the passenger's side on 1992 Prelude. On 1990-92 Accord the A/T control unit is located on the front passenger floor beside the engine control unit (PGM-FI ECU). The A/T control unit is closest to the passenger door.

## Hydraulic Control

The valve assembly includes the main valve body, secondary valve body, servo valve body, regulator valve body and throttle valve body. They are bolted to the torque converter housing as an assembly.

The main valve body contains the manual valve, 1-2 shift valve, 2-3 shift valve, cooler relief valve, lockup shift valve, lockup control valve, 3-2 kick-down valve, modulator valve, CPC valve and oil pump gears.

The secondary valve body includes the 4th exhaust valve, 3rd kick-down valve, 3-4 shift valve, servo control valve, orifice control valve and the 2nd orifice control valve.

The 1st/2nd accumulator body contains the 1st & 2nd accumulators.

The servo valve body contains the 1st-hold, 3rd, and 4th accumulator pistons and servo valves. The regulator valve body contains the regulator valve, T/C check valve, and the lockout timing valve. The throttle body contains the throttle B valve and relief valve.

Fluid from the regulator passes through the manual valve to the various control valves.

The clutches receive oil from their respective feed pipes or internal hydraulic circuit.

## Shift Control Mechanism

Input from various sensors located throughout the car determines which shift control solenoid valve the A/T control unit will activate. Activating a shift control solenoid valve changes modulator pressure, causing a shift valve to move. This pressurizes a line to one of the clutches, engaging that clutch and its corresponding gear.

## Lockup Mechanism

In **D<sub>4</sub>**, in 2nd, 3rd and 4th, (and **D<sub>3</sub>** in 3rd, 1992 Prelude) fluid is drained from the front of the torque converter through an oil passage, causing the lockup piston to be held against the torque converter cover. As this takes place, the mainshaft rotates at the same speed as the engine crankshaft. Together with hydraulic control, the A/T control unit optimizes the timing of the lockup mechanism.

The lockup valves control the range of lockup according to lockup control solenoid valves A and B, and throttle valve B. When lockup control solenoid valves A and B activate, modulator pressure changes. Lockup control solenoid valves A and B are mounted on the torque converter housing, and are controlled by the A/T control unit.

## CLUTCH APPLICATION CHART PX4B/APXA/MPWA/MP1A

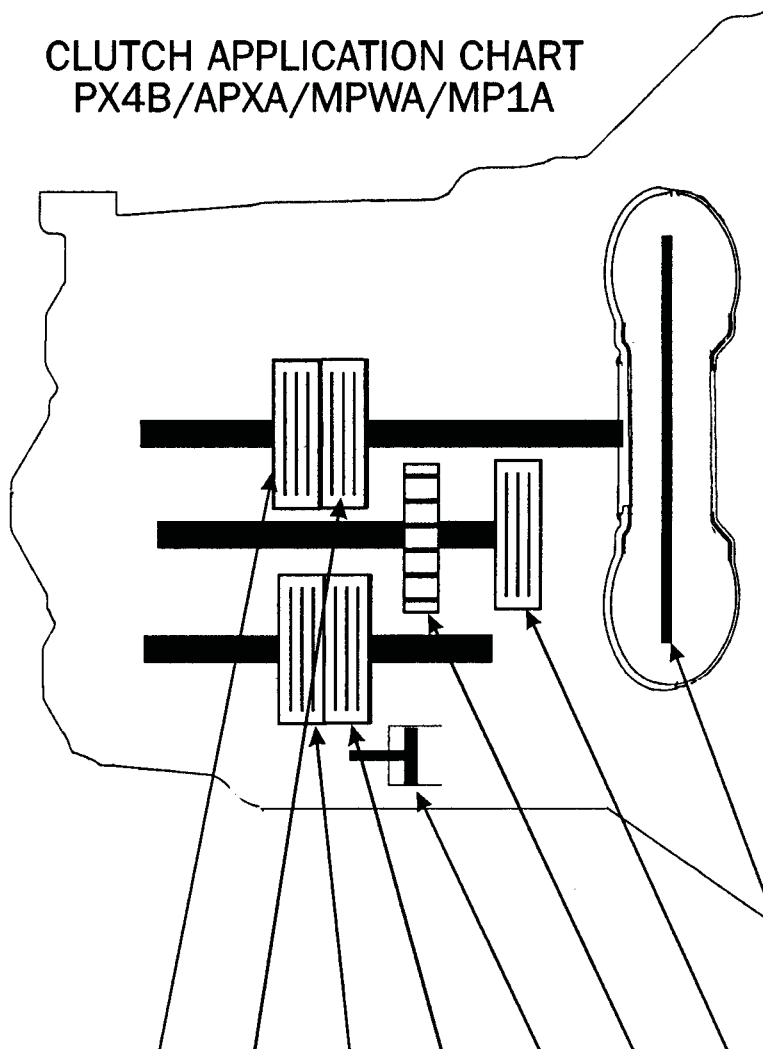

SELECTOR POSITION	GEAR	4TH CLUTCH	3RD CLUTCH	2ND CLUTCH	1ST CLUTCH	SERVO	ONE WAY CLUTCH	1ST HOLD CLUTCH	TCC CLUTCH
R	R	ON				ON			
D4	1				ON		ON <sup>5</sup>		
	2			ON	ON <sup>2</sup>				ON <sup>3</sup>
	3		ON		ON <sup>2</sup>				ON <sup>3</sup>
	4	ON			ON <sup>2</sup>				ON <sup>3</sup>
D3	1				ON <sup>2</sup>		ON <sup>5</sup>		
	2			ON	ON <sup>2</sup>				
	3		ON		ON <sup>2</sup>				ON <sup>3/4</sup>
2	2			ON	ON <sup>2</sup>				
1	1				ON <sup>2</sup>		ON <sup>5</sup>	ON	

2 - ON BUT NOT EFFECTIVE

3 - MAY BE ON DEPENDING ON VEHICLE CONDITION

4 - MP1A ONLY

5 - NOT EFFECTIVE ON ENGINE BRAKING



## Electronic Control System

### Electronic Control System

The electronic control system consists of the A/T control unit, sensors, and 4 solenoid valves. Shifting and lockup are electronically controlled for comfortable driving under all conditions.

The A/T control unit is located below the dashboard, behind the right side kick panel on the passenger's side.

### Shift Control

Getting a signal from each sensor, the A/T control unit determines the appropriate gear and activates shift control solenoid valves A and/or B.

The combination of driving signals to shift control solenoid valves A and B is shown in the table below.

Shift control solenoid valve Range (gear)	A	B
<b>1</b> (1st)	ON	OFF
<b>2</b> (2nd)	ON	ON
<b>D<sub>4</sub></b> <b>D<sub>3</sub></b> (1st)	OFF	ON
<b>D<sub>4</sub></b> <b>D<sub>3</sub></b> (2nd)	ON	ON
<b>D<sub>4</sub></b> <b>D<sub>3</sub></b> (3rd)	ON	OFF
<b>D<sub>4</sub></b> (4th)	OFF	OFF
<b>R</b>	ON	OFF

### Lockup Control

From sensor input signals, the A/T control unit determines whether to turn the lockup ON or OFF and activates lockup control solenoid valve A and/or B accordingly.

The combination of driving signals to lockup control solenoid valves A and B is shown in the table below.

Solenoid valve Lockup condition	A	B
Lockup OFF	OFF	OFF
Lockup, slight	ON	Duty operation OFF ← → ON
Lockup, half	ON	ON
Lockup, full	ON	ON
Lockup during deceleration	ON	Duty operation OFF ← → ON

## 1990-91-92 ACCORD

ProCarManuals.com

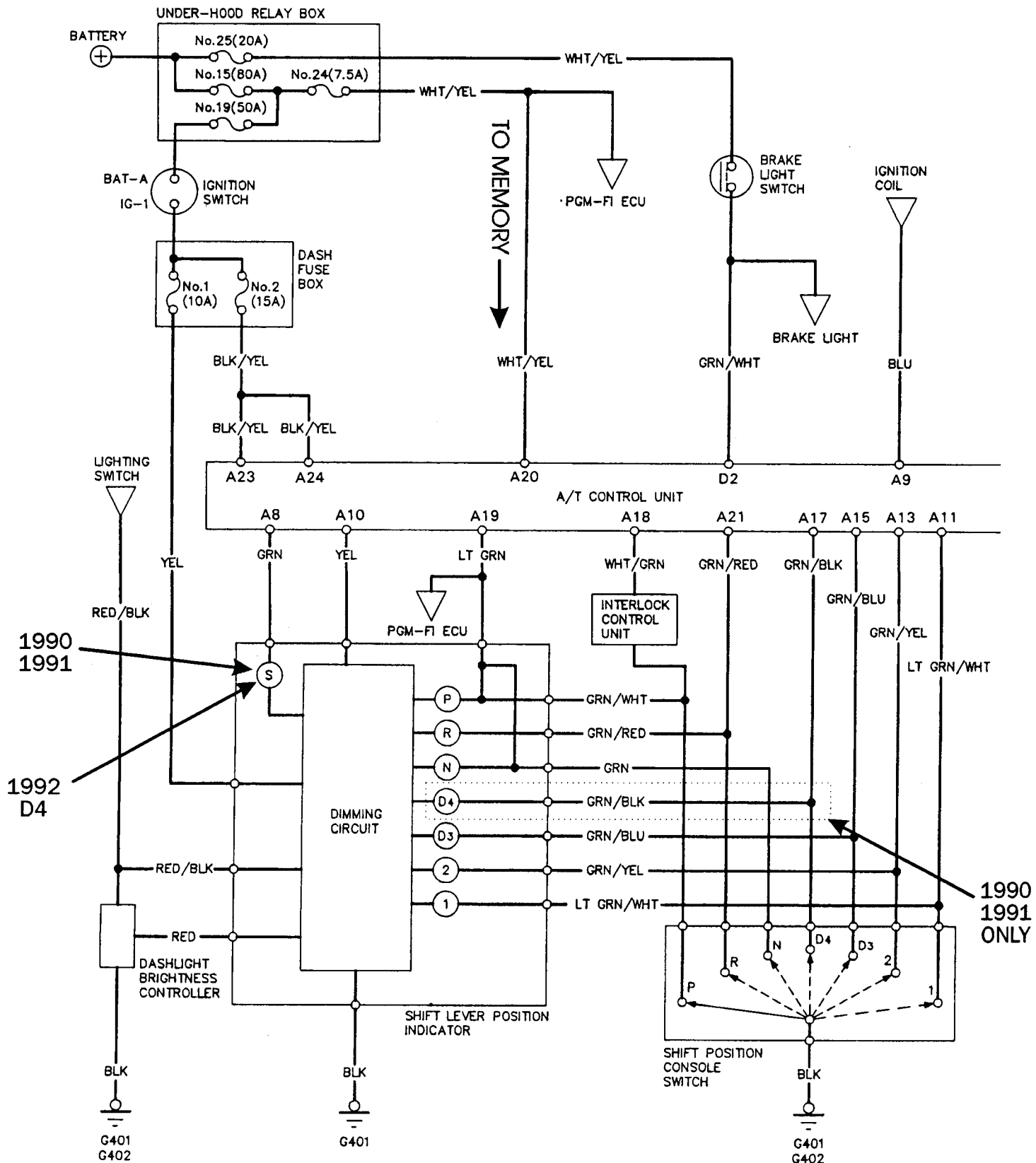

## 1990-91-92 ACCORD

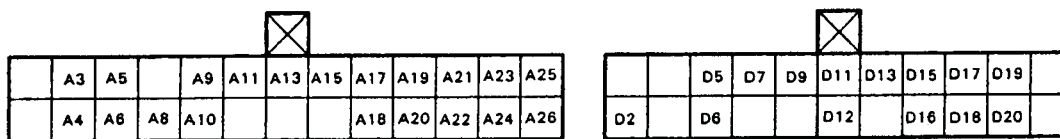
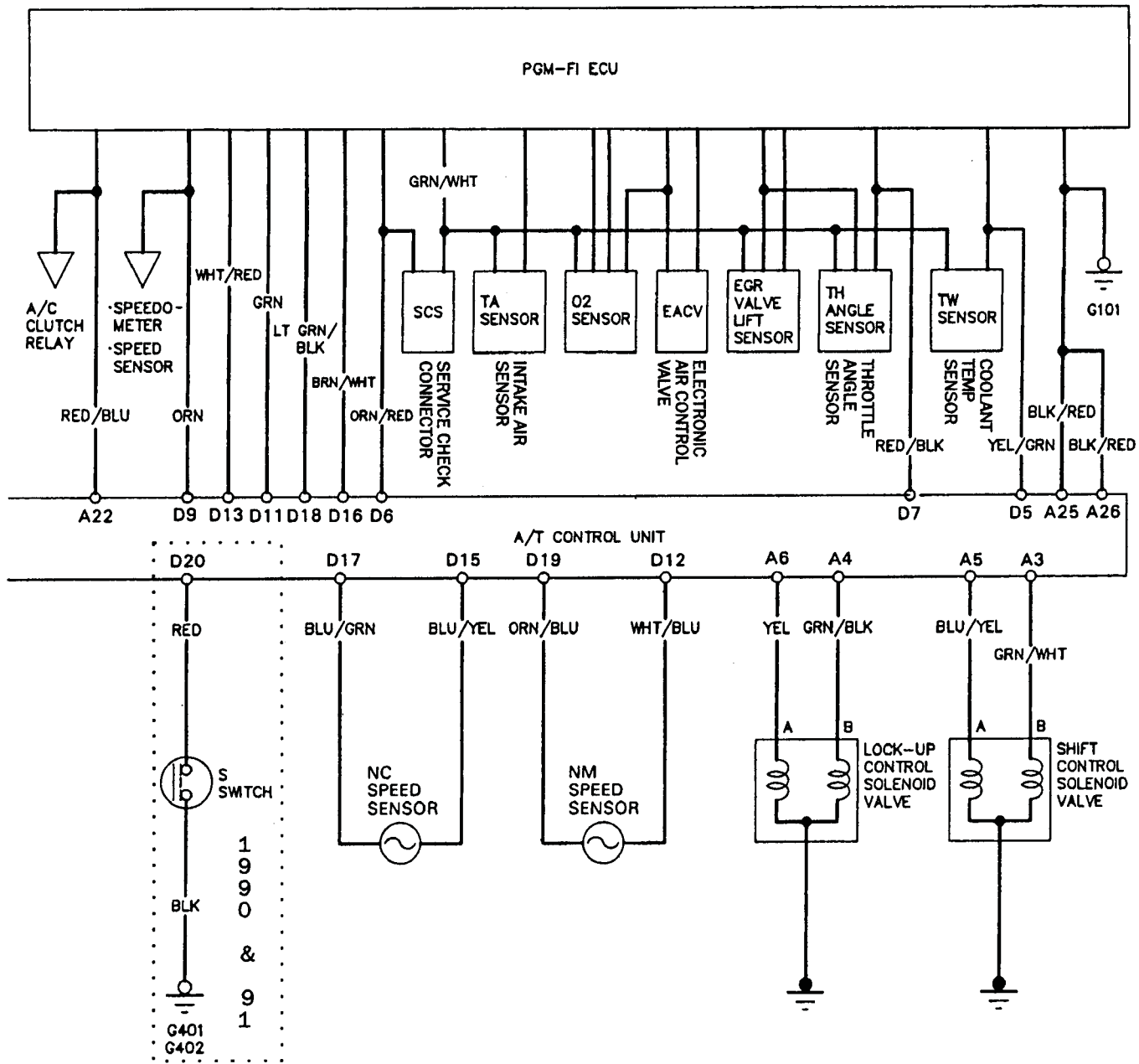

TERMINAL LOCATION

1990-91

## 1992 PRELUDE

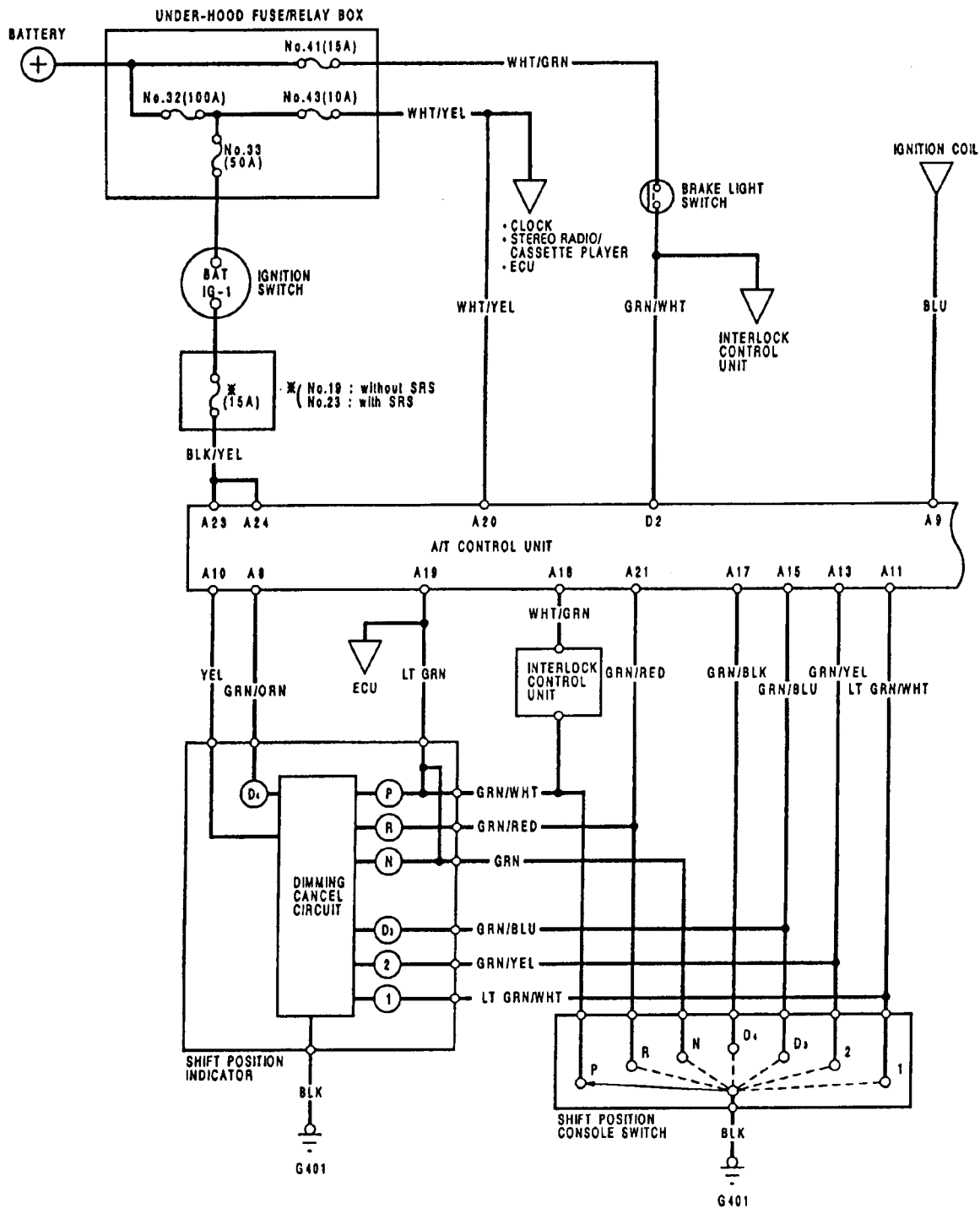

## 1992 PRELUDE

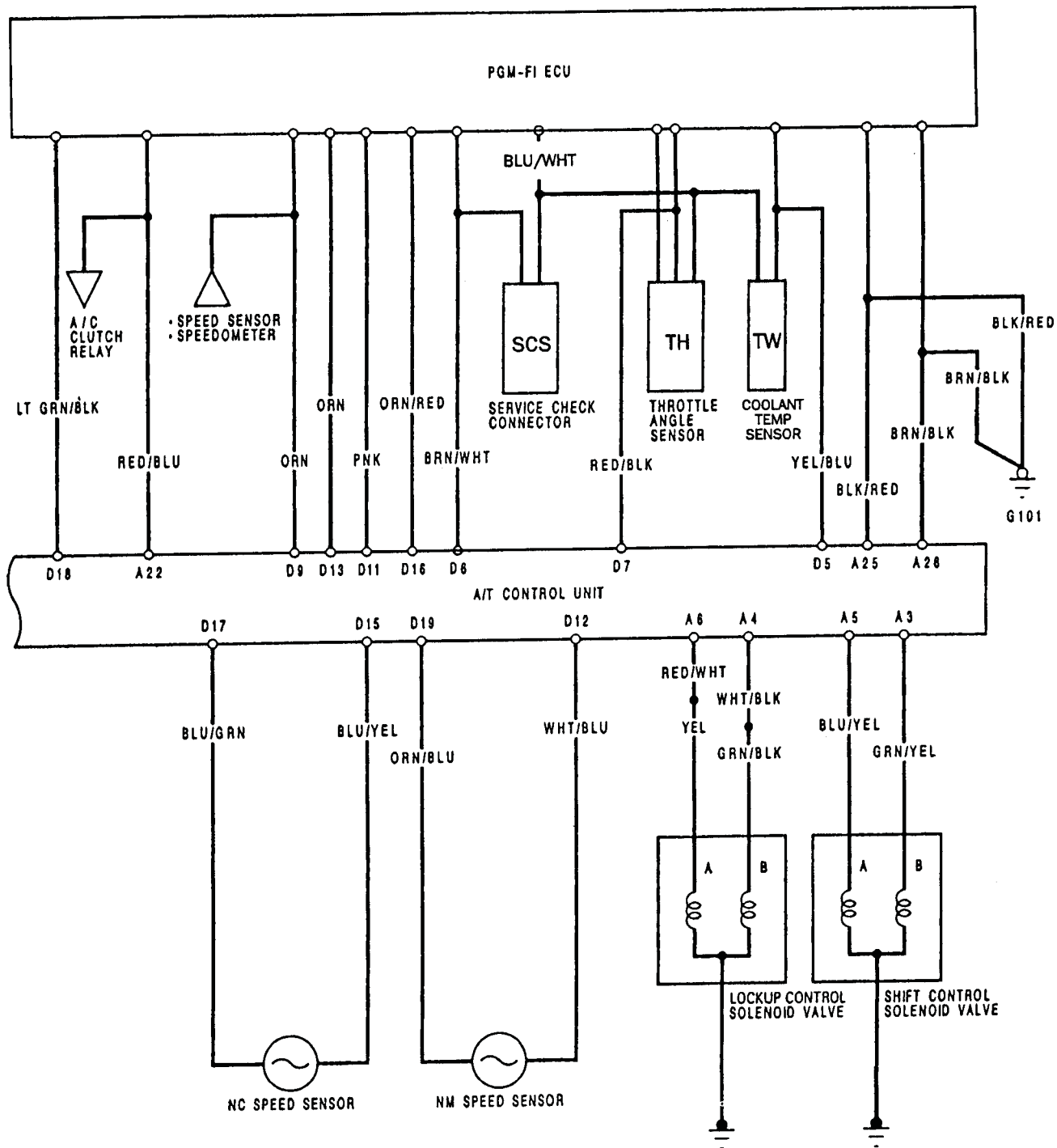

	A3	A5	A9	A11	A13	A15	A17	A19	A21	A23	A25
	A4	A6	A8	A10			A18	A20	A22	A24	A26

	D5	D7	D9	D11	D13	D15	D17	D19
D2	D6			D12		D16	D18	D20

A/T Control Unit Terminal Locations

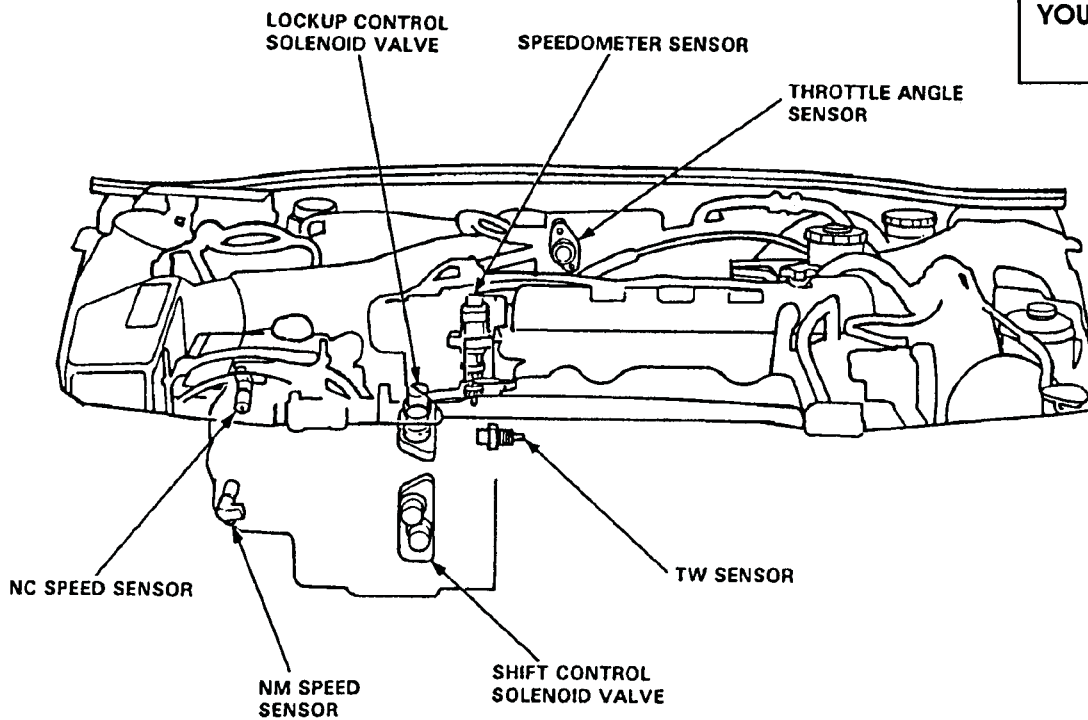
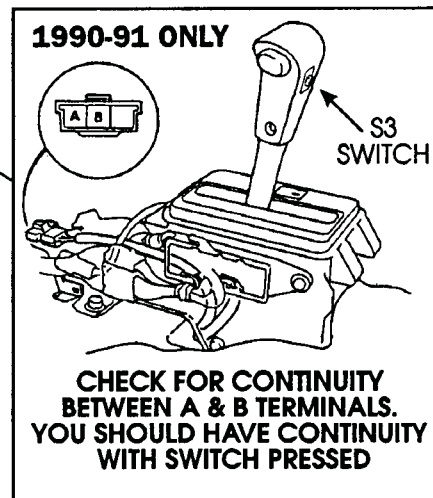
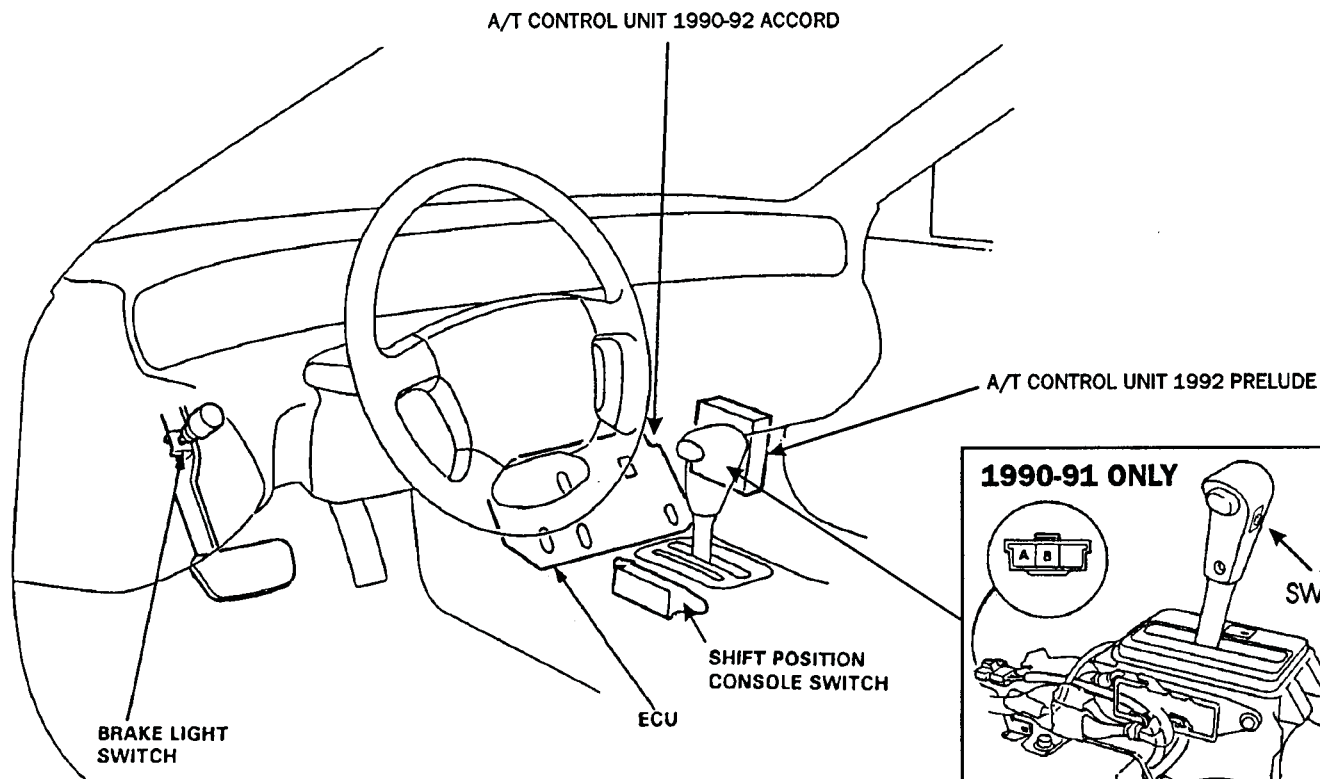

## ACCORD A/T CONTROL UNIT SHOWN (PRELUDE A/T CONTROL UNIT IN PASSENGER SIDE KICK PANNEL)

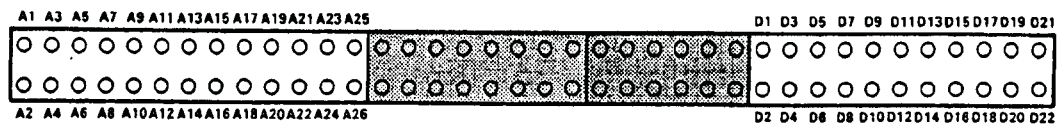
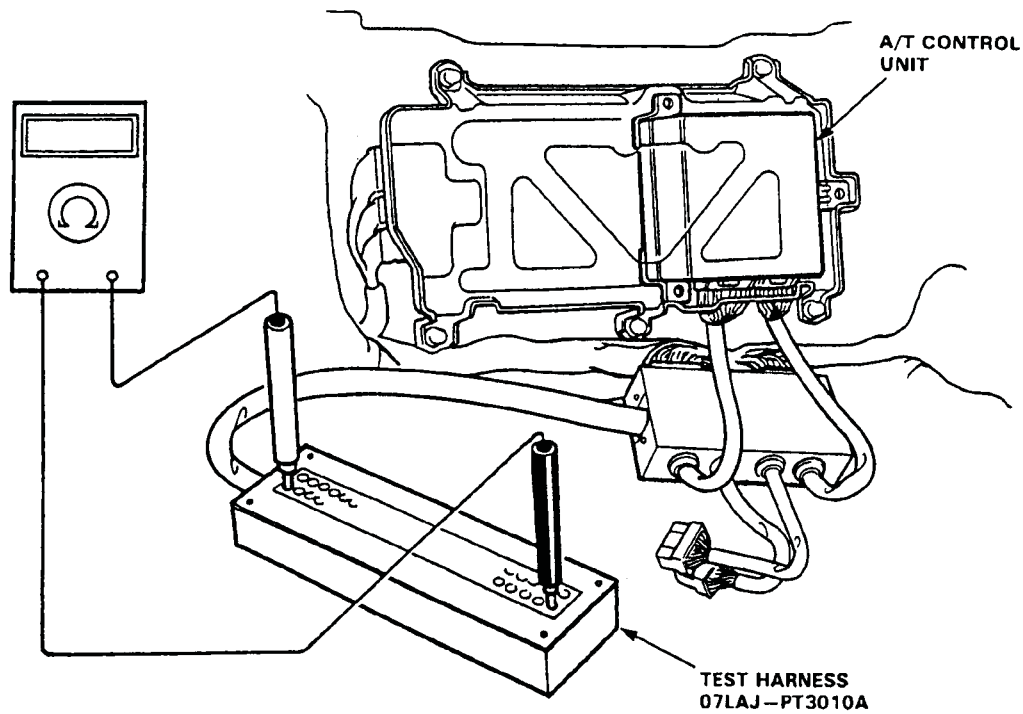

Terminal Locations

**NOTE:**

- Only the A and D sections of the Test Harness are used for A/T troubleshooting.
- Unless otherwise noted, use only the Digital Multimeter, KS-AHM-32-003, for testing.

When the A/T control unit senses an abnormality in the input or output system, the S indicator light 1990-91, or D4 indicator light 1992, in the gauge assembly will blink. However, when the Service Check Connector (located to the lower right of the glove compartment) is connected with a jumper wire, The S indicator light or D4 indicator light will blink the problem code when the ignition switch is turned on.

When the S or D4 light has been reported on, connect the two terminals of the service check connector together. Then turn on the ignition switch and observe the S indicator light, or the D4 indicator light.

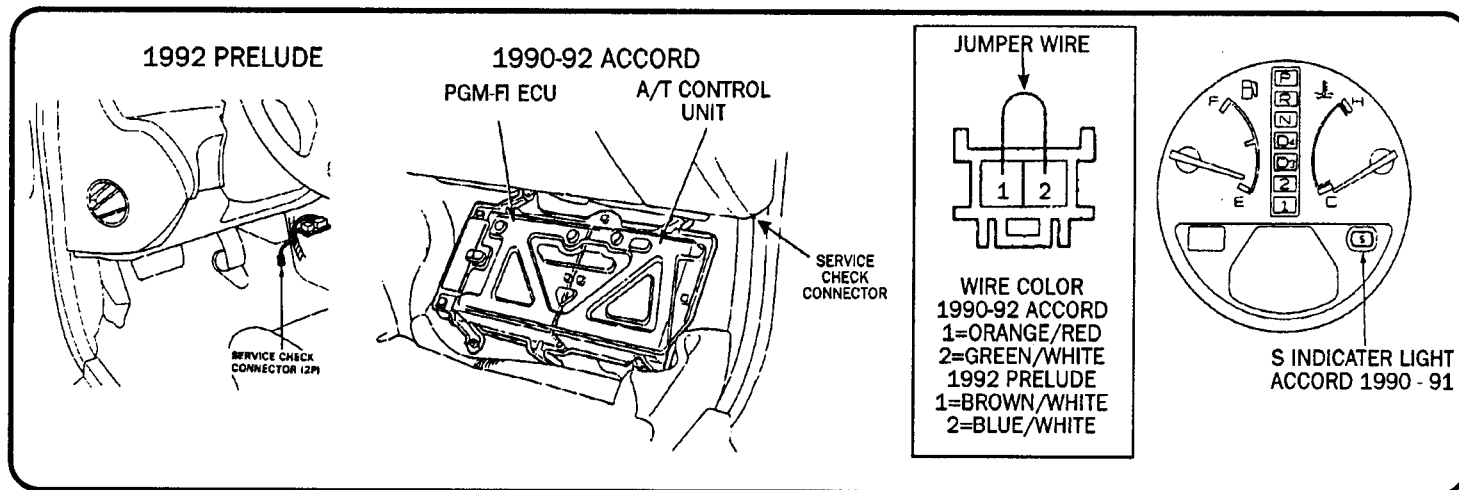

Problem codes 1 through 9 are indicated by individual short blinks, problem codes 10 through 15 are indicated by a series of long and short blinks. One long blink equals 10 short blinks. Add the long and short blinks to determine the problem code. After determining the problem code, refer to the electrical system Symptom-to-component chart.

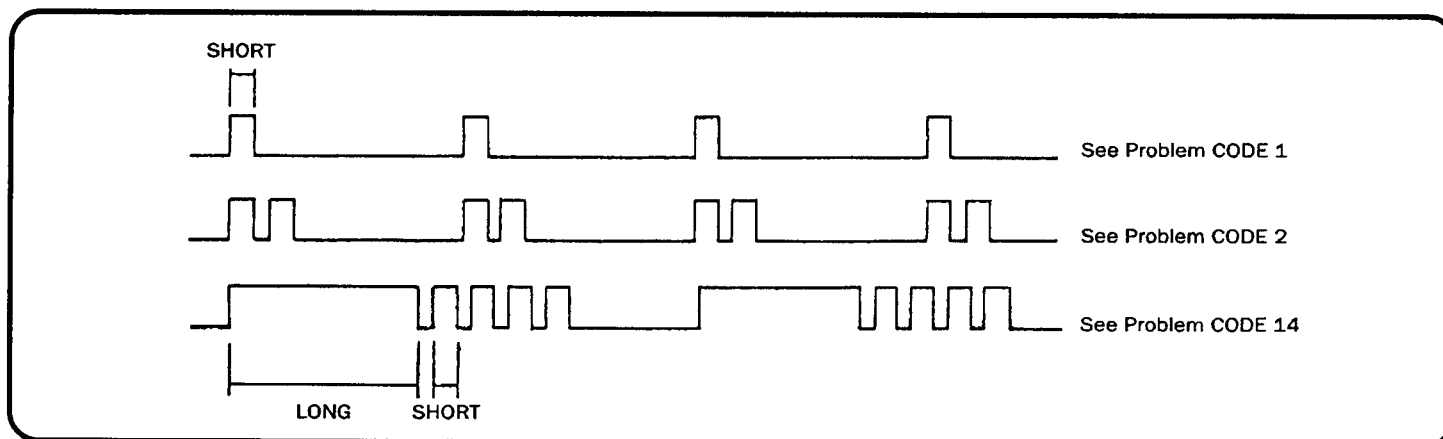

## ACCORD

Some PGM-FI problems will also make the S or D4 indicator light come on. After repairing the PGM-FI system, disconnect the Back Up fuse (7.5 A) in the under hood relay box for more than 10 seconds to reset the A/T control unit memory.

NOTE: Disconnecting the back up fuse also cancels the radio preset stations and the clock setting.

## PRELUDE

Some PGM-FI problems will also make the D4 indicator light come on. After repairing the PGM-FI system, disconnect the clock radio fuse (10 A) in the under hood fuse/relay box for more than 10 seconds to reset the A/T control unit memory.

NOTE: Disconnecting the clock radio fuse also cancels the radio anti-theft code, preset stations and the clock settings. Get the customers anti-theft code to reset the radio.



## Technical Service Information

Number of S/D4 indicator light blinks while Service Check Connector is jumped.	S or D4 indicator light	Possible Cause	Symptom	Refer to page
1	Blinks	<ul style="list-style-type: none"><li>• Disconnected lock-up control solenoid valve A connector</li><li>• Short or open in lock-up control solenoid valve A wire</li><li>• Faulty lock-up control solenoid valve A</li></ul>	<ul style="list-style-type: none"><li>• Lock-up clutch does not engage.</li><li>• Lock-up clutch does not disengage.</li><li>• Unstable idle speed.</li></ul>	15
2	Blinks	<ul style="list-style-type: none"><li>• Disconnected lock-up control solenoid valve B connector</li><li>• Short or open in lock-up control solenoid valve B wire</li><li>• Faulty lock-up control solenoid valve B</li></ul>	<ul style="list-style-type: none"><li>• Lock-up clutch does not engage.</li></ul>	16
3	Blinks or OFF	<ul style="list-style-type: none"><li>• Disconnected throttle angle sensor connector</li><li>• Short or open in throttle angle sensor wire</li><li>• Faulty throttle angle sensor</li></ul>	<ul style="list-style-type: none"><li>• Lock-up clutch does not engage.</li></ul>	17
4	Blinks	<ul style="list-style-type: none"><li>• Disconnected sensor connector</li><li>• Short or open in speed sensor wire</li><li>• Faulty speed sensor</li></ul>	<ul style="list-style-type: none"><li>• Lock-up clutch does not engage.</li></ul>	18
5	Blinks	<ul style="list-style-type: none"><li>• Short in shift position console switch wire</li><li>• Faulty shift position console switch</li></ul>	<ul style="list-style-type: none"><li>• Fails to shift other than 2nd ↔ 4th gears.</li><li>• Lock-up clutch does not engage.</li></ul>	19
6	OFF	<ul style="list-style-type: none"><li>• Disconnected shift position console switch connector</li><li>• Open in shift position console switch wire</li><li>• Faulty shift position console switch</li></ul>	<ul style="list-style-type: none"><li>• Fails to shift other than 2nd ↔ 4th gears.</li><li>• Lock-up clutch does not engage.</li><li>• Lock-up clutch engages and disengages alternately.</li></ul>	21
7	Blinks	<ul style="list-style-type: none"><li>• Disconnected shift control solenoid valve A connector</li><li>• Short or open in shift control solenoid valve A wire</li><li>• Faulty shift control solenoid valve A</li></ul>	<ul style="list-style-type: none"><li>• Fails to shift (between 1st ↔ 4th, 2nd ↔ 4th or 2nd ↔ 3rd gears only).</li><li>• Fails to shift (stuck in 4th gear)</li></ul>	23
8	Blinks	<ul style="list-style-type: none"><li>• Disconnected shift control solenoid valve B connector</li><li>• Short or open in shift control solenoid valve B wire</li><li>• Faulty shift control solenoid valve B</li></ul>	<ul style="list-style-type: none"><li>• Fails to shift (stuck in 1st or 4th gears).</li></ul>	24



## Technical Service Information

Number of S/D4 indicator light blinks while Service Check Connector is jumped.	S/D4 indicator light	Possible Cause	Symptom	Refer to page
9	Blinks	<ul style="list-style-type: none"> <li>• Disconnected NC speed sensor connector</li> <li>• Short or open in the NC speed sensor wire</li> <li>• Faulty NC speed sensor</li> </ul>	<ul style="list-style-type: none"> <li>• Lock-up clutch does not engage.</li> </ul>	25
10	Blinks	<ul style="list-style-type: none"> <li>• Disconnected water temperature sensor connector</li> <li>• Short or open in the water temperature sensor wire</li> <li>• Faulty water temperature sensor</li> </ul>	<ul style="list-style-type: none"> <li>• Lock-up clutch does not engage.</li> </ul>	27
11	OFF	<ul style="list-style-type: none"> <li>• Disconnected ignition coil connector</li> <li>• Short or open in ignition coil wire</li> <li>• Faulty ignition coil</li> </ul>	<ul style="list-style-type: none"> <li>• Lock-up clutch does not engage.</li> </ul>	28
14	OFF	<ul style="list-style-type: none"> <li>• Short or open in FAS wire</li> <li>• Trouble in PGM-FI unit</li> </ul>	<ul style="list-style-type: none"> <li>• Transmission jerks hard when shifting.</li> </ul>	29
15	OFF	<ul style="list-style-type: none"> <li>• Disconnected NM speed sensor connector</li> <li>• Short or open in NM speed sensor wire</li> <li>• Faulty NM speed sensor</li> </ul>	<ul style="list-style-type: none"> <li>• Transmission jerks hard when shifting.</li> </ul>	31

If the self-diagnosis S/D4 indicator light does not blink, perform an inspection according to the table listed below.

Sympton	Probable Cause	Ref. page
S/D4 indicator light is on steady, not blinking whenever the ignition is on.	—————	33
S/D4 indicator light does not come on for 2 seconds after ignition is first turned on.	—————	35
No 2-1 shift after releasing the brake at a stop in the D position, or shift lever cannot be moved from the P position with the brake pedal depressed.	Check brake light signal.	38
Lock-up clutch does not have duty operation (ON-OFF).	Check A/C signal with A/C on.	39
Lock-up clutch does not engage.		

- If a customer describes the symptoms for codes 3, 6, or 11, yet the S/D4 indicator light is not blinking, it will be necessary to recreate the symptom by test driving, and then checking the S/D4 indicator light with the ignition still ON.
- If the S/D4 indicator light displays codes other than those listed above or stays lit continuously, the control unit is faulty.
- Sometimes the S/D4 indicator light and the Check Engine light may come on simultaneously. If so, check the PGM-FI system according to the number of blinks on the PGM-FI ECU self-diagnosing indicator, then reset the memory by removing the Back-Up fuse in the under hood fuse/relay box for more than 10 seconds. Drive the vehicle for several minutes at speed over 30 mph (50 km/h), then recheck the lights.

**NOTE:** Disconnecting the Back up fuse also cancels the radio preset stations and the clock setting. Make note of the radio presets before removing the fuse so you can reset them.

Self-diagnosis S/D4 indicator light blinks once.

POSSIBLE CAUSE

Disconnect the 26P connector from the control unit.

- Disconnected lockup control solenoid valve A connector
- Short or open in lockup control solenoid valve A wire
- Faulty Lockup control solenoid valve A
- Improperly wired in add on accessory

Turn the ignition switch ON.

Measure the voltage between the A6 and A25 or A26 terminals

NOTE: VIEW FROM WIRE SIDE

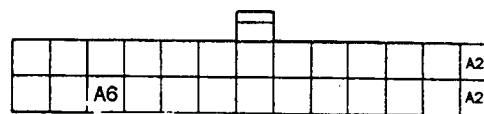

Is there voltage?

YES

Repair short to power source in the wire between the A6 terminal and the lock-up control solenoid valve A.

NO

Turn the ignition switch OFF.

Disconnect the 2P connector from the lock-up control solenoid valve assembly.

Check for continuity between the A6 and A26 or A26 terminals

Is there continuity?

YES

Repair short to ground in the wire between the A6 terminal and the lock-up control solenoid valve A.

NO

Connect the 2P connector to the lock-up control solenoid valve assembly.

Measure the resistance between the A6 and A26 or A26 terminals

Is the resistance 12–24 Ω?

NO

Check for open in the wire between the A6 terminal and the lock-up control solenoid valve A. If wire is OK, check the lock-up control solenoid valve A.

YES

Check for loose control unit connectors. If necessary, substitute a known-good control unit and recheck.



Self-diagnosis S/D4 indicator light blinks three times.

**POSSIBLE CAUSE**

- Disconnected throttle angle sensor connector
- Short or open in throttle angle sensor wire
- Faulty throttle angle sensor
- Improperly wired in add on accessory

Turn the ignition switch ON.

Does the check engine light stay on

**YES** Repair the PGM-FI System.

NOTE: View from wire side.

NO

Turn the ignition switch OFF.

Disconnect the 26P and 22P connectors from the control unit.

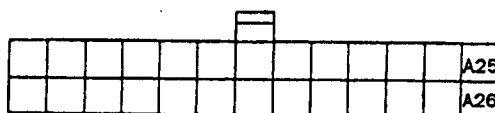

Turn the ignition switch ON.

Measure the voltage between the D18 and A25 terminals

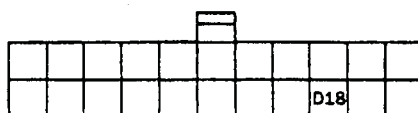

Is the voltage 4.75 – 5.25 V?

**NO** Repair open or short in the wire between the D18 A/T control unit terminal and the D14 terminal of the engine ECU.

YES

Turn the ignition switch OFF.

Connect the Test Harness between the connectors and the control unit.

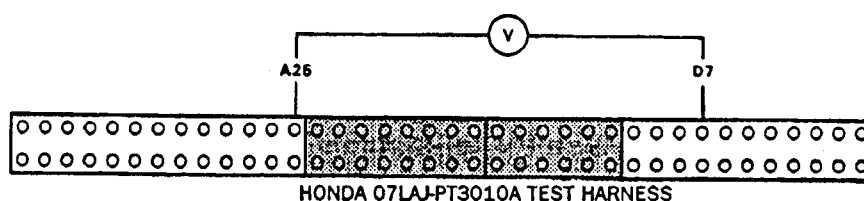

Turn the ignition switch ON.

Measure the voltage between the D7 and A25 terminals.

Is the voltage approx. 0.5V ?

**NO** Repair open or short in RED/BLK wire between the D7 terminal and the throttle angle sensor.

Check for loose A/T control unit connectors. If necessary, substitute a known-good A/T control unit and recheck.



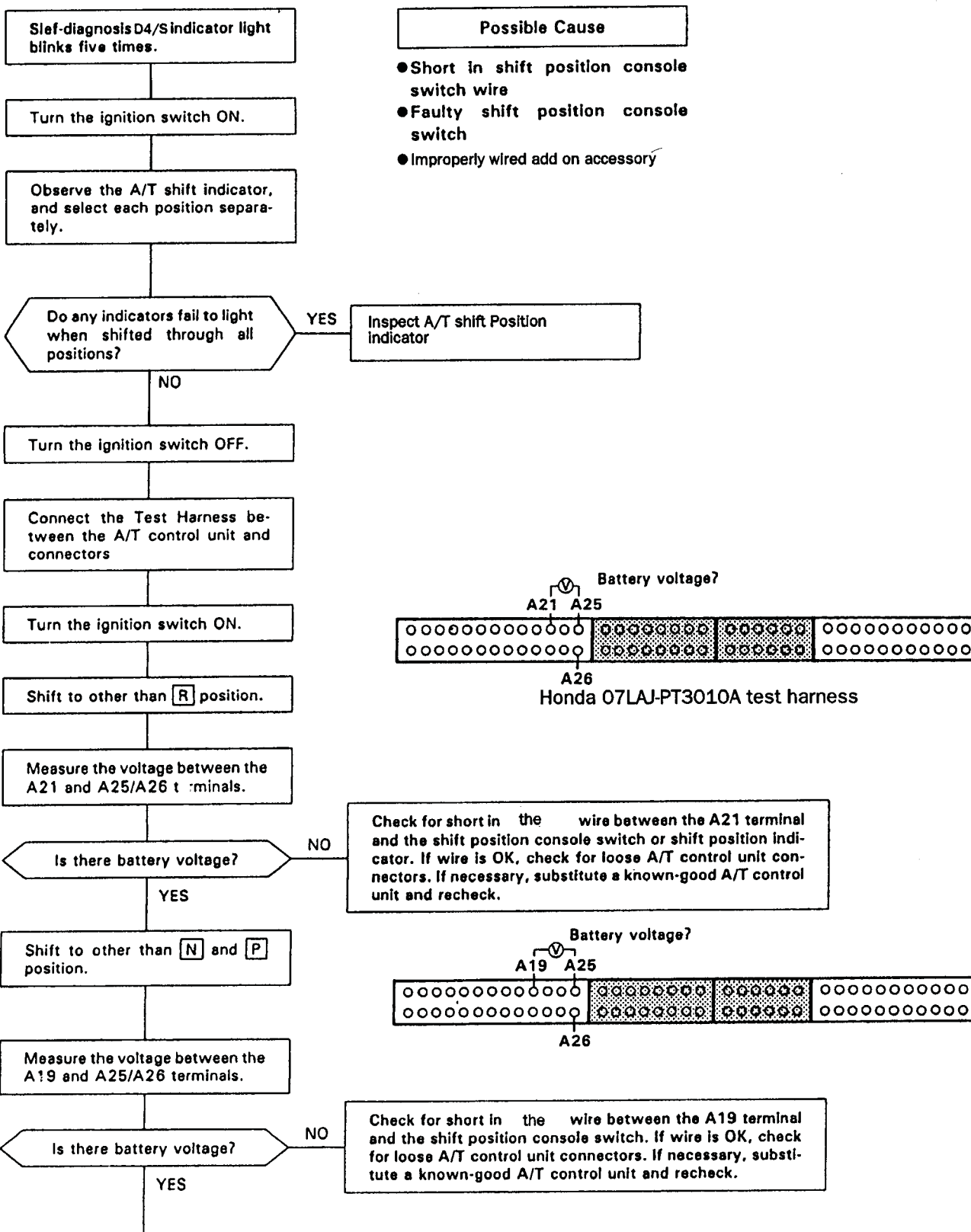

CONTINUED ON NEXT PAGE

CONTINUED FROM PREVIOUS PAGE

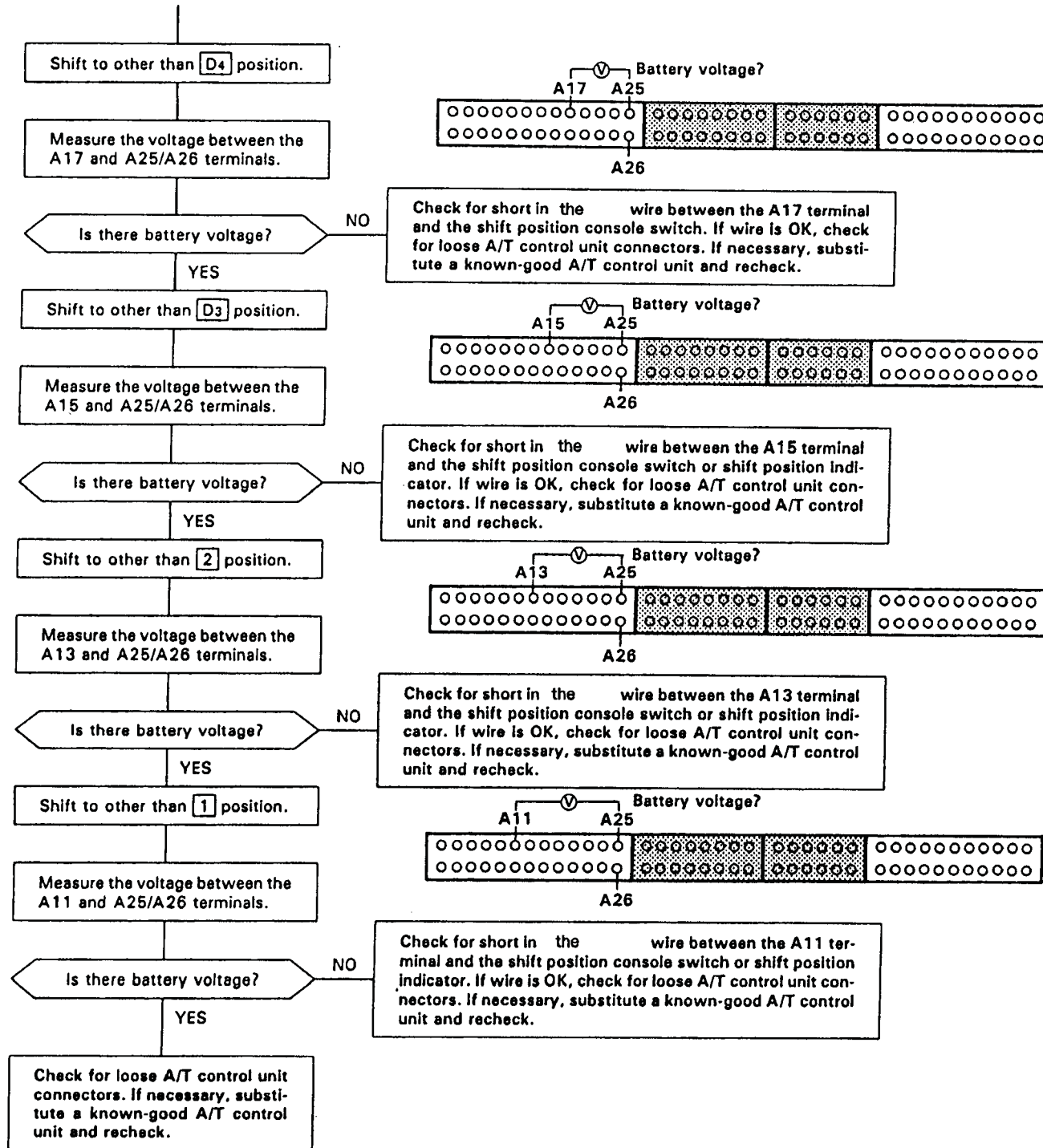

Self-diagnosis S/D4 indicator light blinks six times.

Connect the Test Harness between the A/T control unit and connectors

Turn the ignition switch ON.

Shift to **R** position.

Measure the voltage between the A21 and A25/A26 terminals.

Is there voltage? YES

Repair open in GRN/RED wire between the A21 terminal and the shift position console switch.

NO

Shift to **N** or **P** position.

Measure the voltage between the A19 and A25/A26 terminals.

Is there voltage? YES

Repair open in LT GRN wire between the A19 terminal and the shift position console switch.

NO

CONTINUED ON NEXT PAGE

### Possible Cause

- Disconnected shift position console switch connector
- Open in shift position console switch wire
- Faulty shift position console switch
- Improperly wired add on accessory

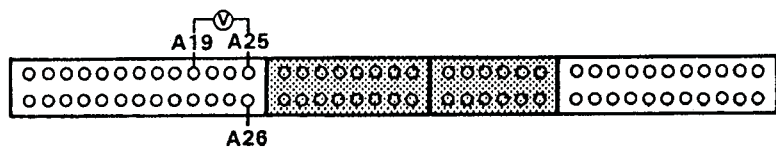
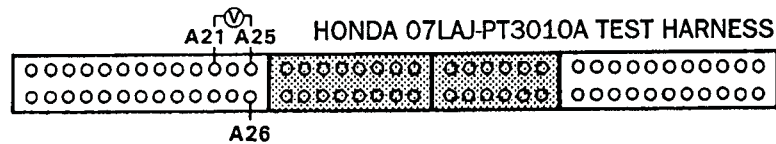

CONTINUED FROM PREVIOUS PAGE

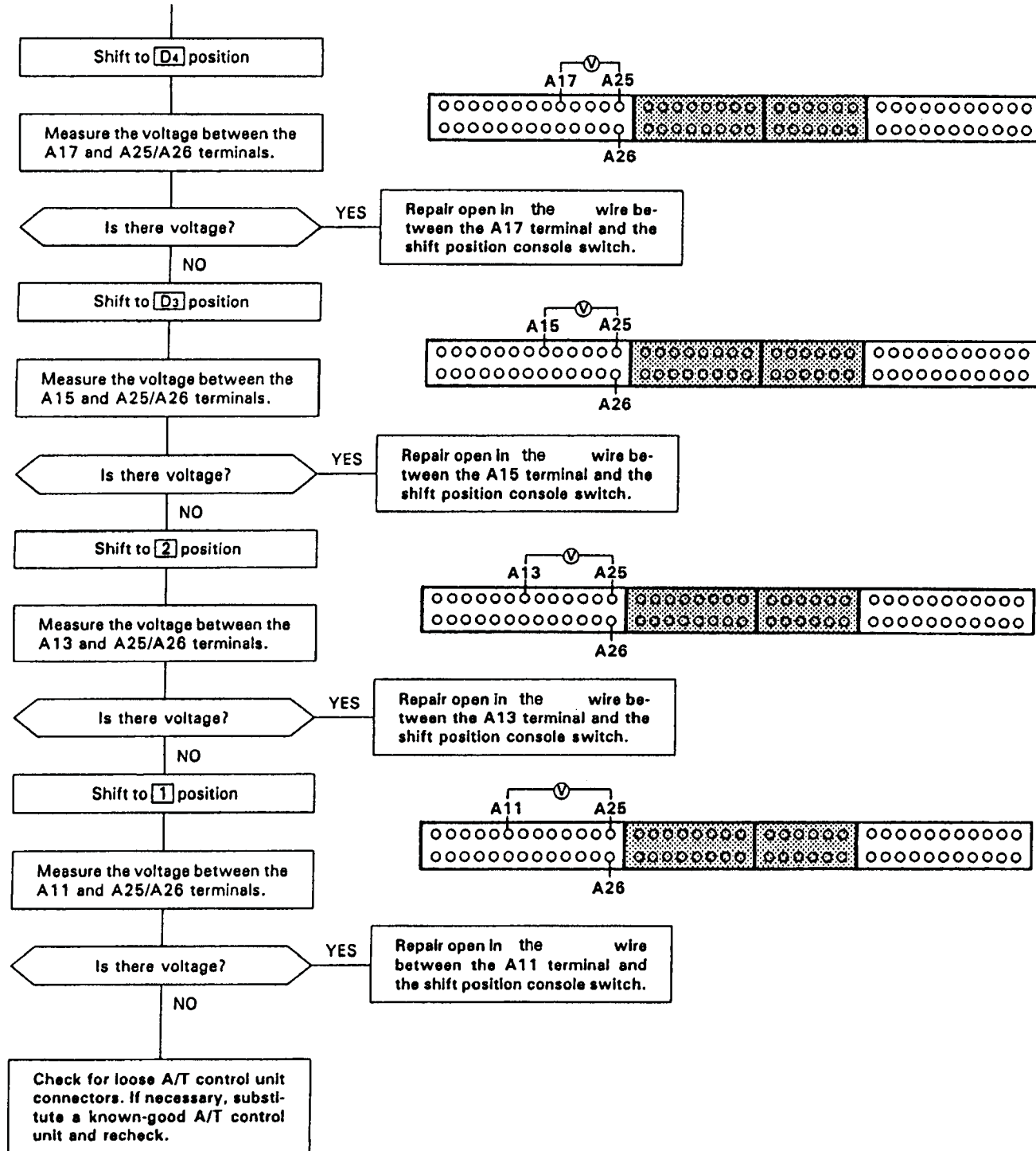

Self-diagnosis S/D4 indicator light blinks seven times.

Disconnect the 26P connector from the control unit.

Turn the ignition switch ON.

Measure the voltage between the A5 and A25 or A26 terminals

Is there voltage?

YES

Repair short to power source in the wire between the A5 terminal and the shift control solenoid valve A.

NO

Turn the ignition switch OFF.

Measure the resistance between the A5 and A25 or A26 terminals

Is the resistance 12–24 Ω?

NO

Check for open in the wire between the A5 terminal and the shift control solenoid valve A. If wire is OK, check the shift control solenoid valve A.

YES

Disconnect the 2P connector from the shift control solenoid valve assembly.

Check for continuity between the A5 and A25 or A26 terminals

Is there continuity?

YES

Repair short to ground in the wire between the A5 terminal and the shift control solenoid valve A.

NO

Connect the 2P connector to the shift control solenoid valve assembly.

Check for loose control unit connectors. If necessary, substitute a known-good control unit and recheck.

POSSIBLE CAUSE

- Disconnected shift control solenoid valve A connector
- Short or open in shift control solenoid valve A wire
- Faulty shift control solenoid valve
- Improperly wired add on accessory

NOTE: View from wire side.

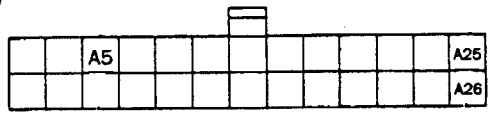

Self-diagnosis S/D4 indicator light blinks eight times.

Disconnect the 26P connector from the control unit.

Turn the ignition switch ON.

Measure the voltage between the A3 and A25 or A26 terminals

Is there voltage?

YES

Repair short to power source in the wire between the A3 terminal and shift control solenoid valve B.

NO

Turn the ignition switch OFF.

Measure the resistance between the A3 and A25 or A26 terminals

Is the resistance 12–24 Ω?

NO

Check for open in the wire between the A3 terminal and the shift control solenoid valve B. If wire is OK, check the shift control solenoid valve B.

YES

Disconnect the 2P connector from the shift control solenoid valve assembly.

Check for continuity between the A3 and A25 or A26 terminals

Is there continuity?

YES

Repair short to ground in the wire between the A3 terminal and the shift control solenoid valve B.

NO

Connect the 2P connector to the shift control solenoid valve assembly.

Check for loose control unit connectors. If necessary, substitute a known-good control unit and recheck.

## POSSIBLE CAUSE

- Disconnected shift control solenoid valve B connector
- Short or open in shift control solenoid valve B
- Faulty shift control solenoid valve B
- Improperly wired add on accessory

NOTE: View from wire side.

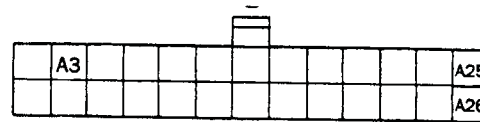

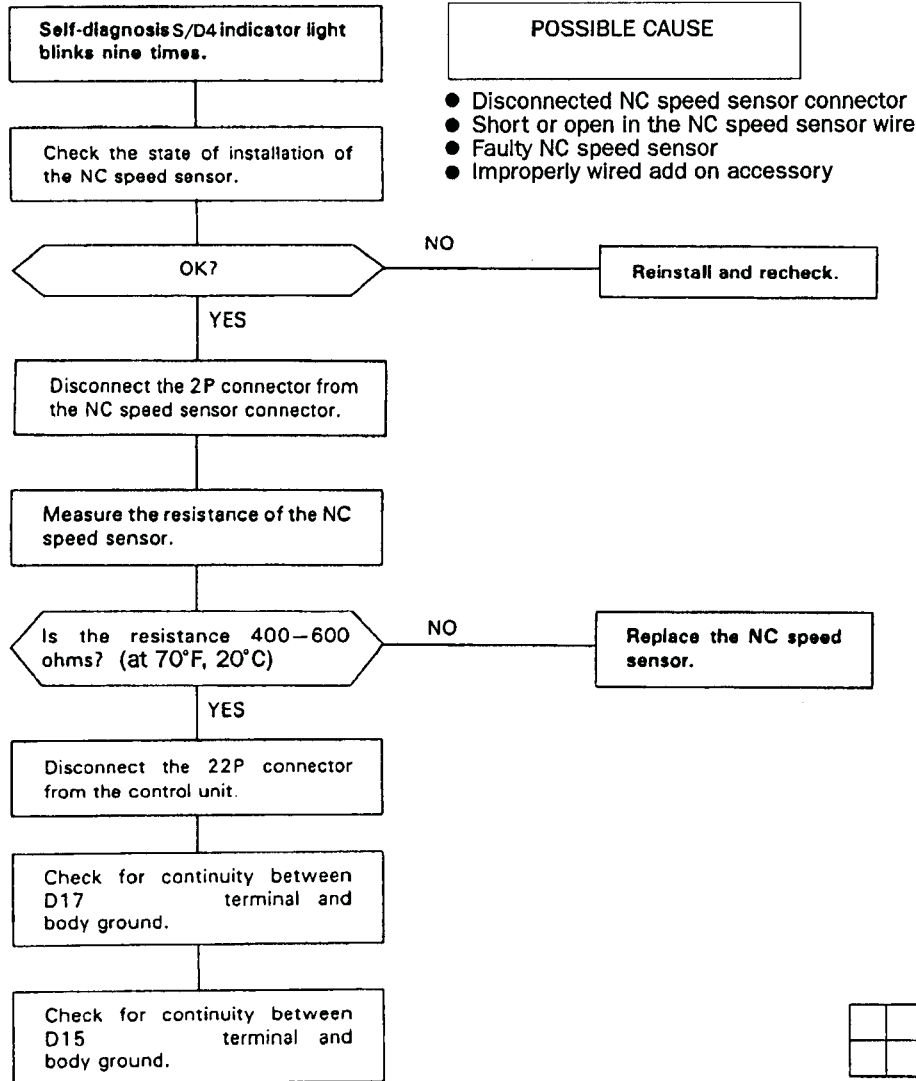

CONTINUED ON  
NEXT PAGE

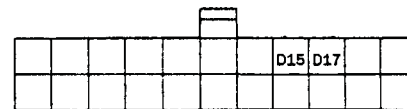

NOTE: View from wire side.



# Technical Service Information

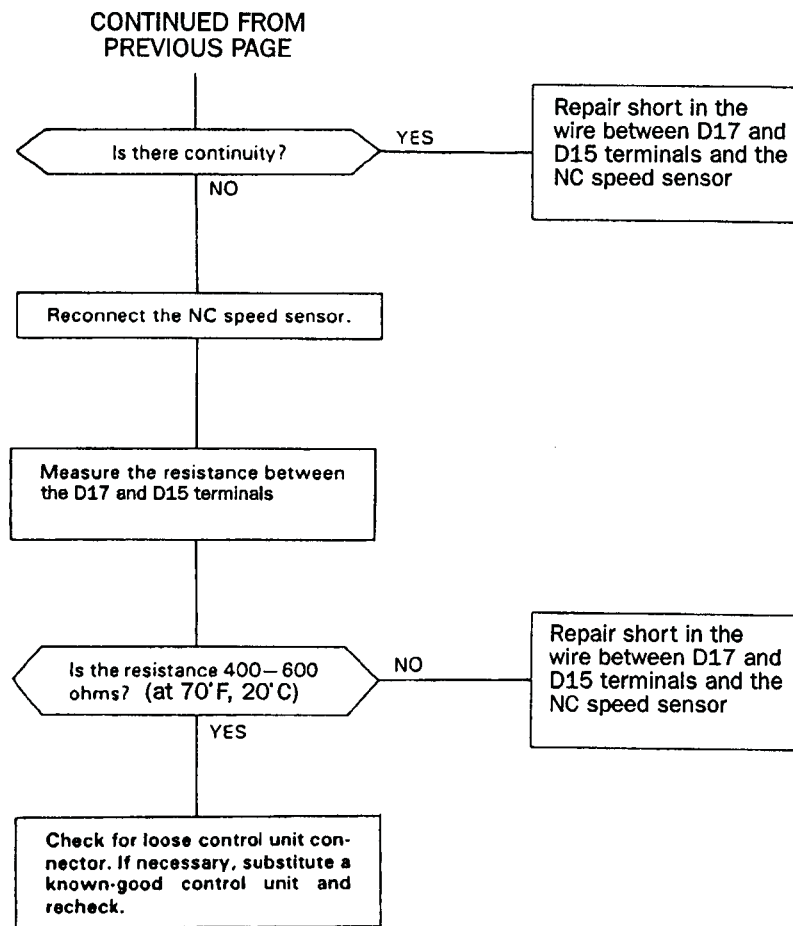

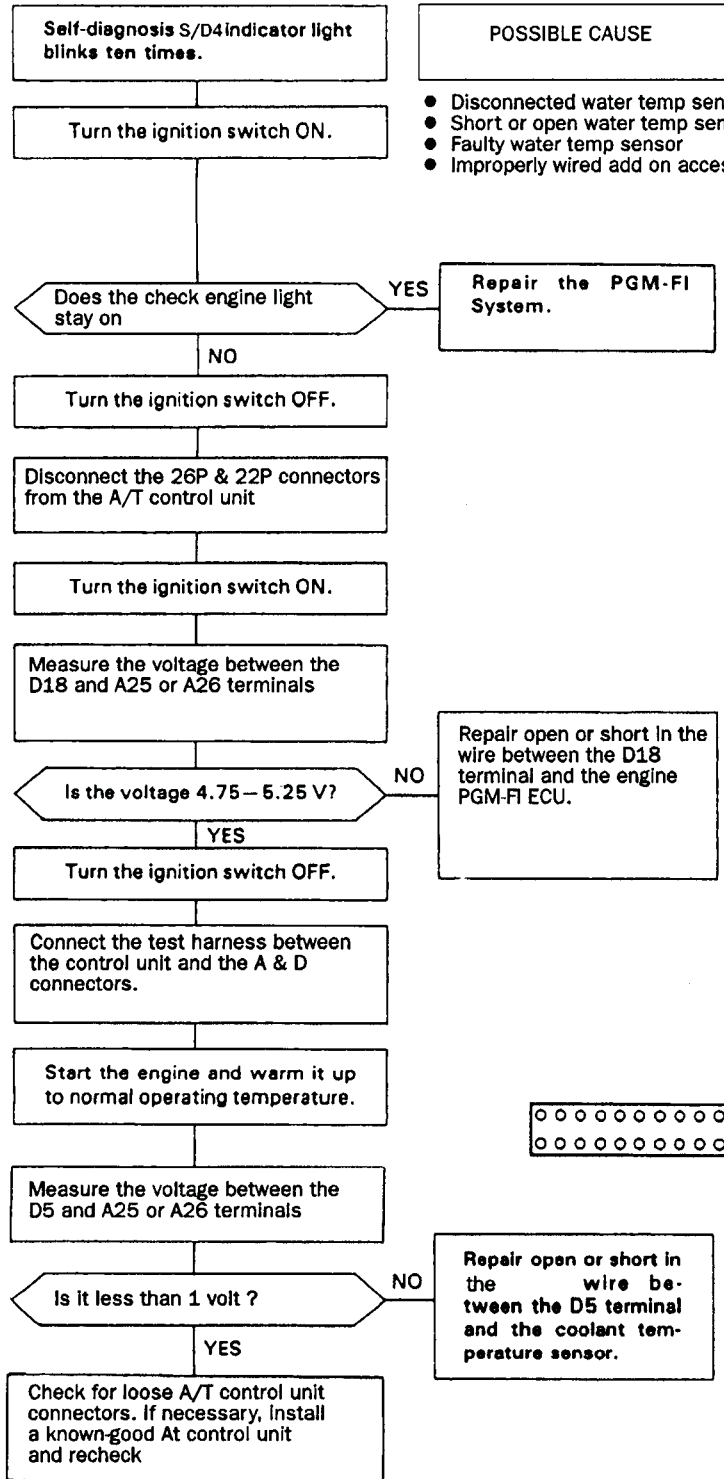

NOTE: View from wire side.

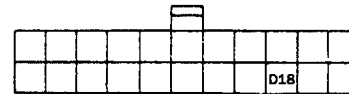
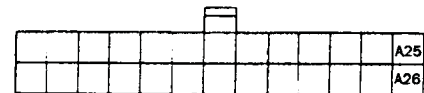

HONDA 07LAJ-PT3010A TEST HARNESS

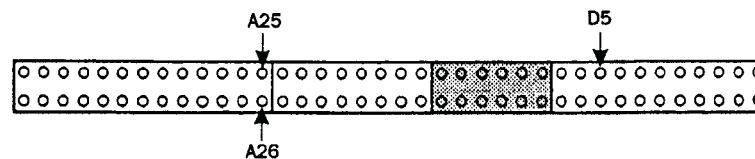

## POSSIBLE CAUSES

- Disconnected ignition coil connector
- Short or open in ignition coil wire
- Faulty ignition coil
- Improperly wired add on accessory

Self-diagnosis S/D4 indicator light blinks eleven times.

Disconnect the 26P connectors from the control unit.

Shift to **P** position.

Measure the voltage between the A9 and A25 or A26 terminals.

Is there battery voltage?

NO

Repair open or short in the wire between the A9 terminal and the ignition coil.

YES

Check for loose control unit connectors. If necessary, substitute a known-good control unit and recheck.

NOTE: View from wire side.

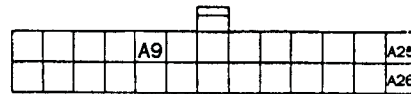

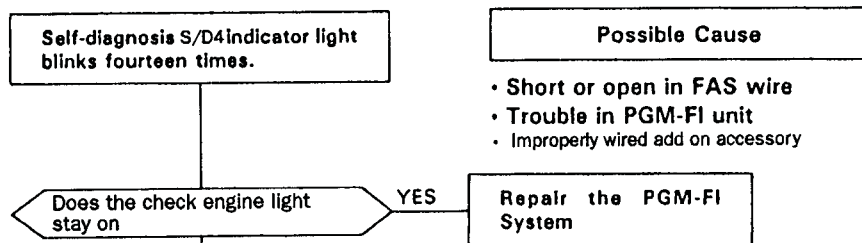

**⚠ WARNING**

- Make sure lifts, jacks and safety stands are placed properly
- While testing, be careful of the rotating front wheels.

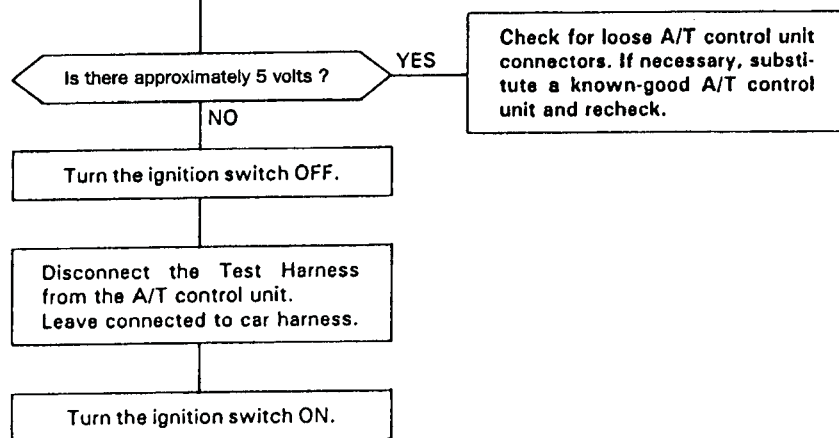
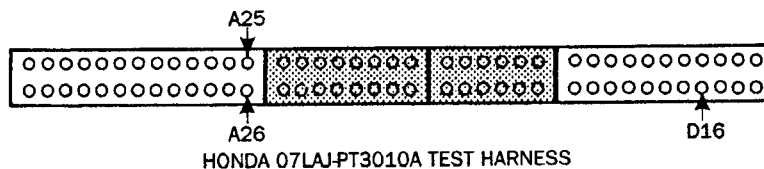
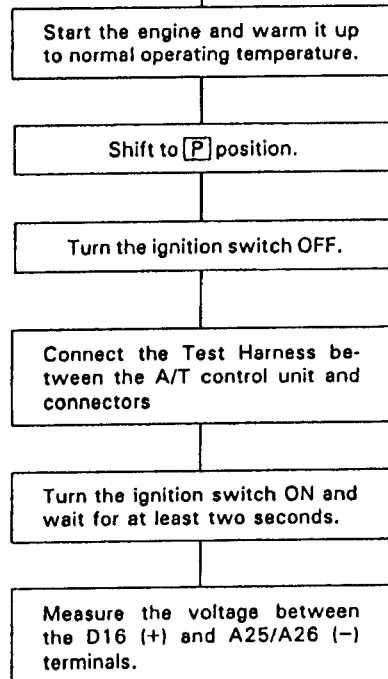

CONTINUED ON NEXT PAGE

CONTINUED FROM PREVIOUS PAGE

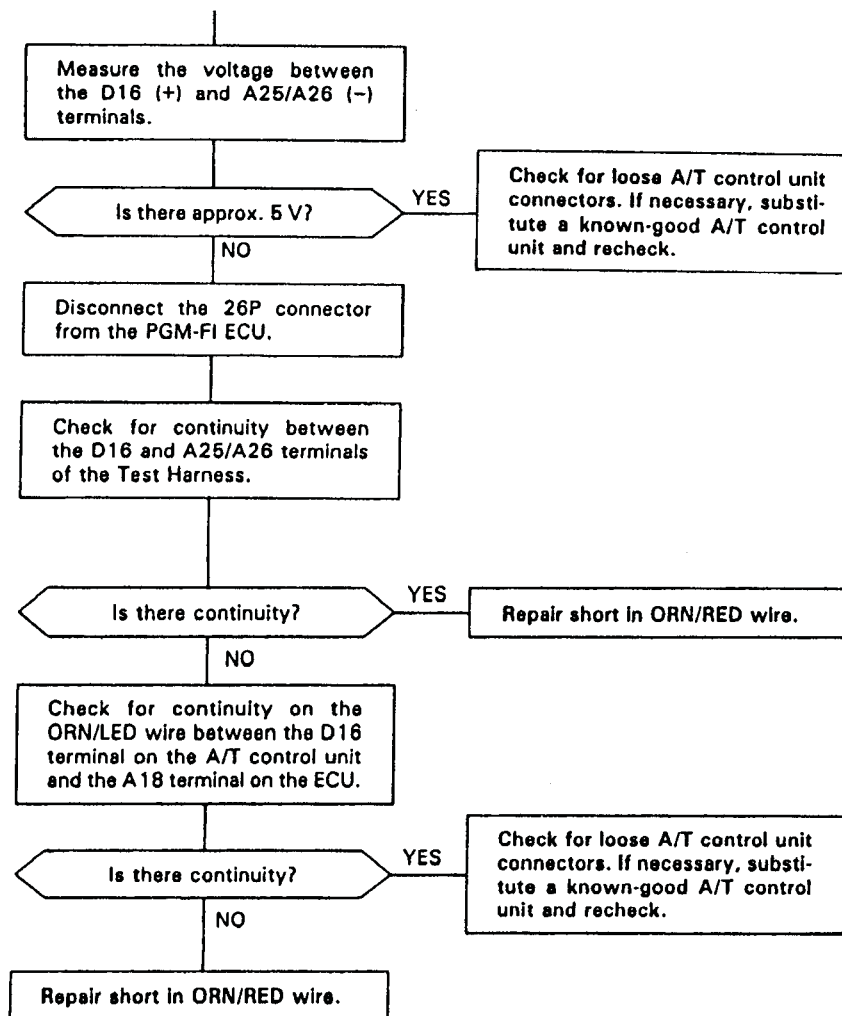





# Technical Service Information

CONTINUED FROM  
PREVIOUS PAGE

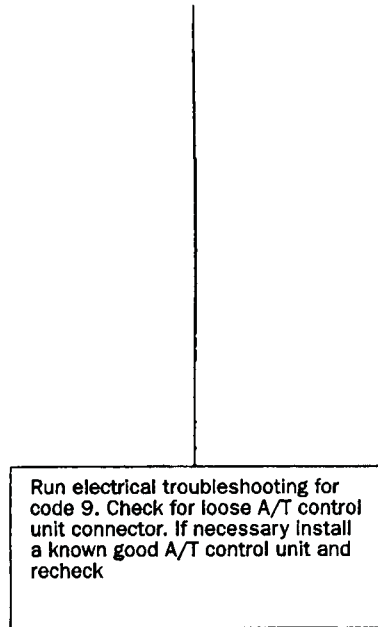

CONTINUED FROM  
PREVIOUS PAGE

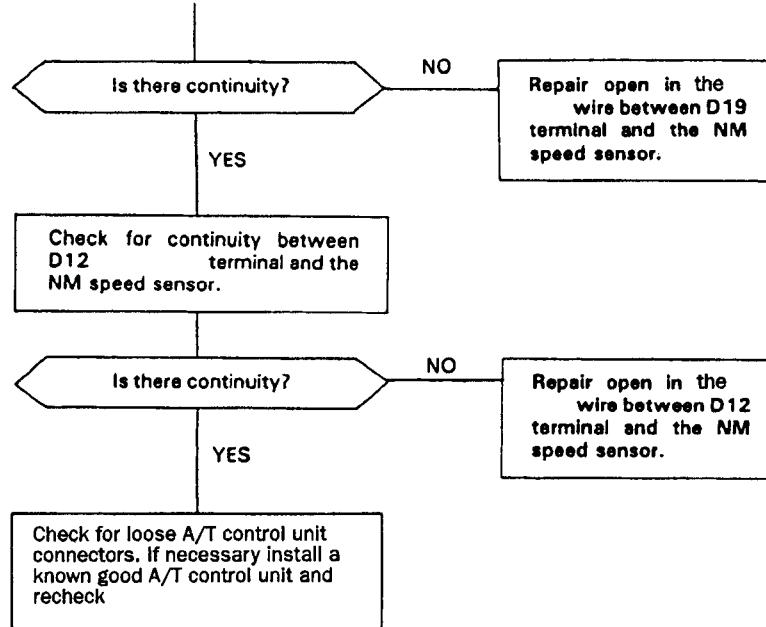

1990-91 ONLY

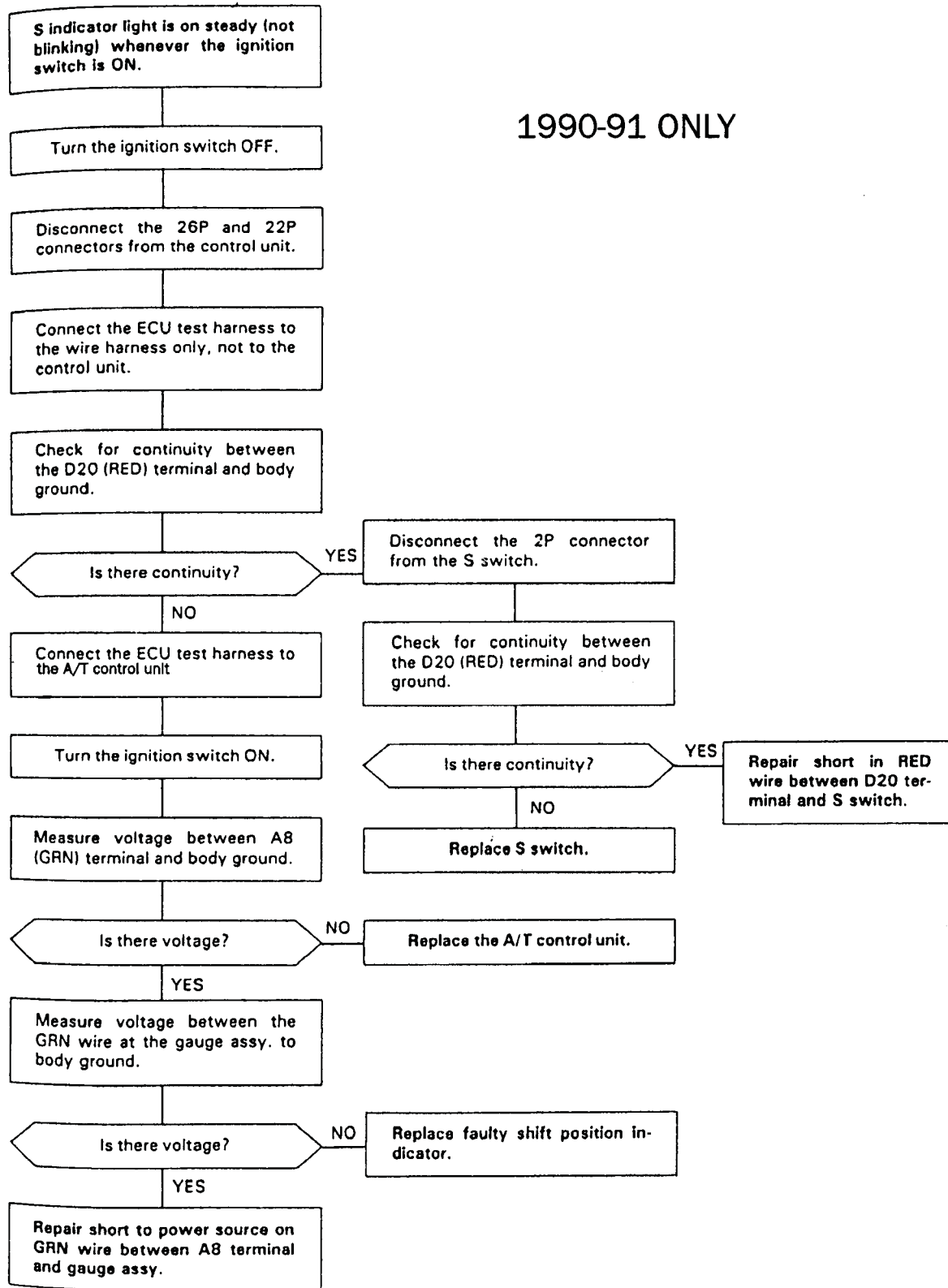

## 1992 ONLY

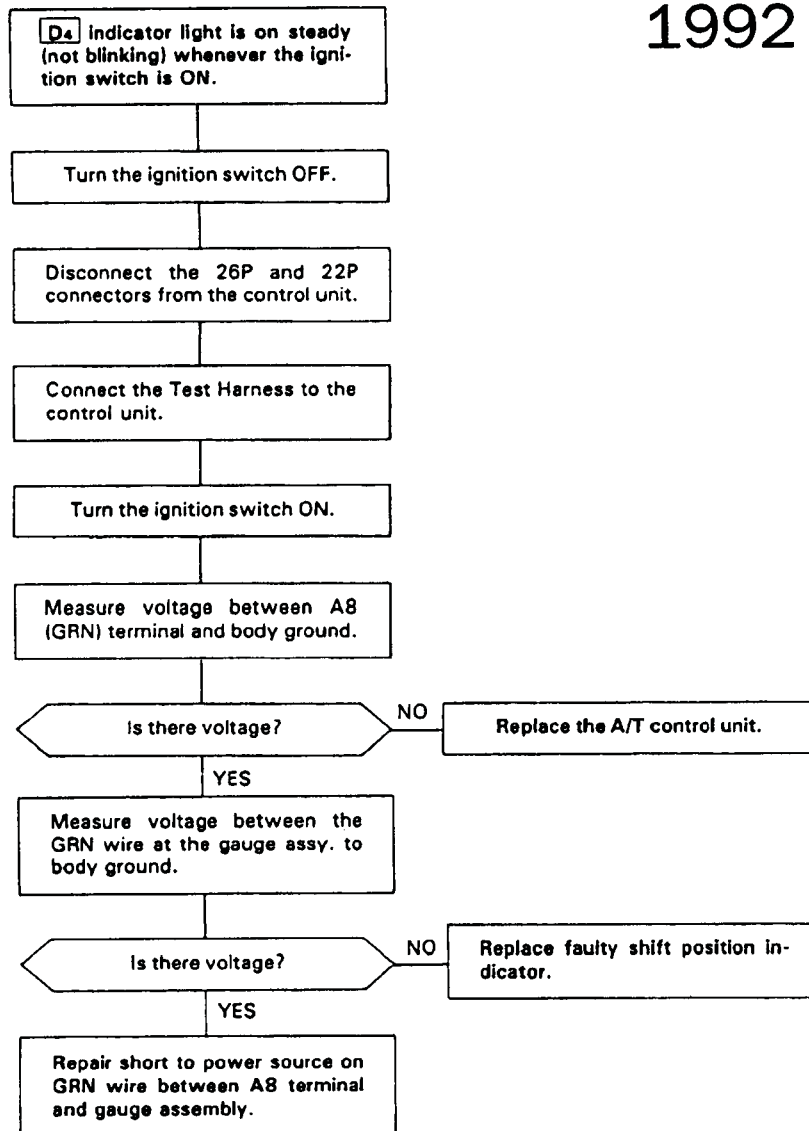

1990-91 ONLY

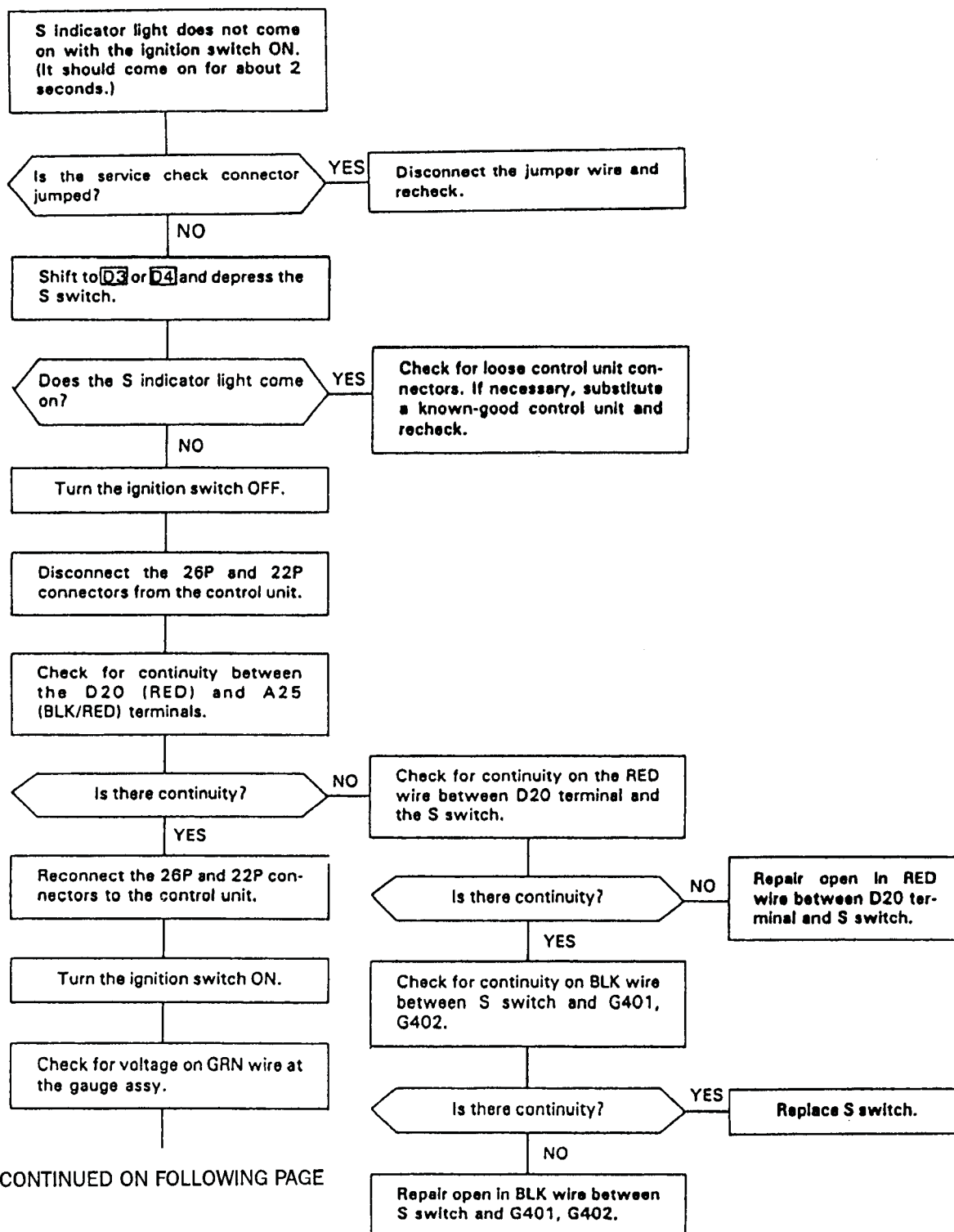

CONTINUED ON FOLLOWING PAGE



# Technical Service Information

CONTINUED FROM PREVIOUS PAGE

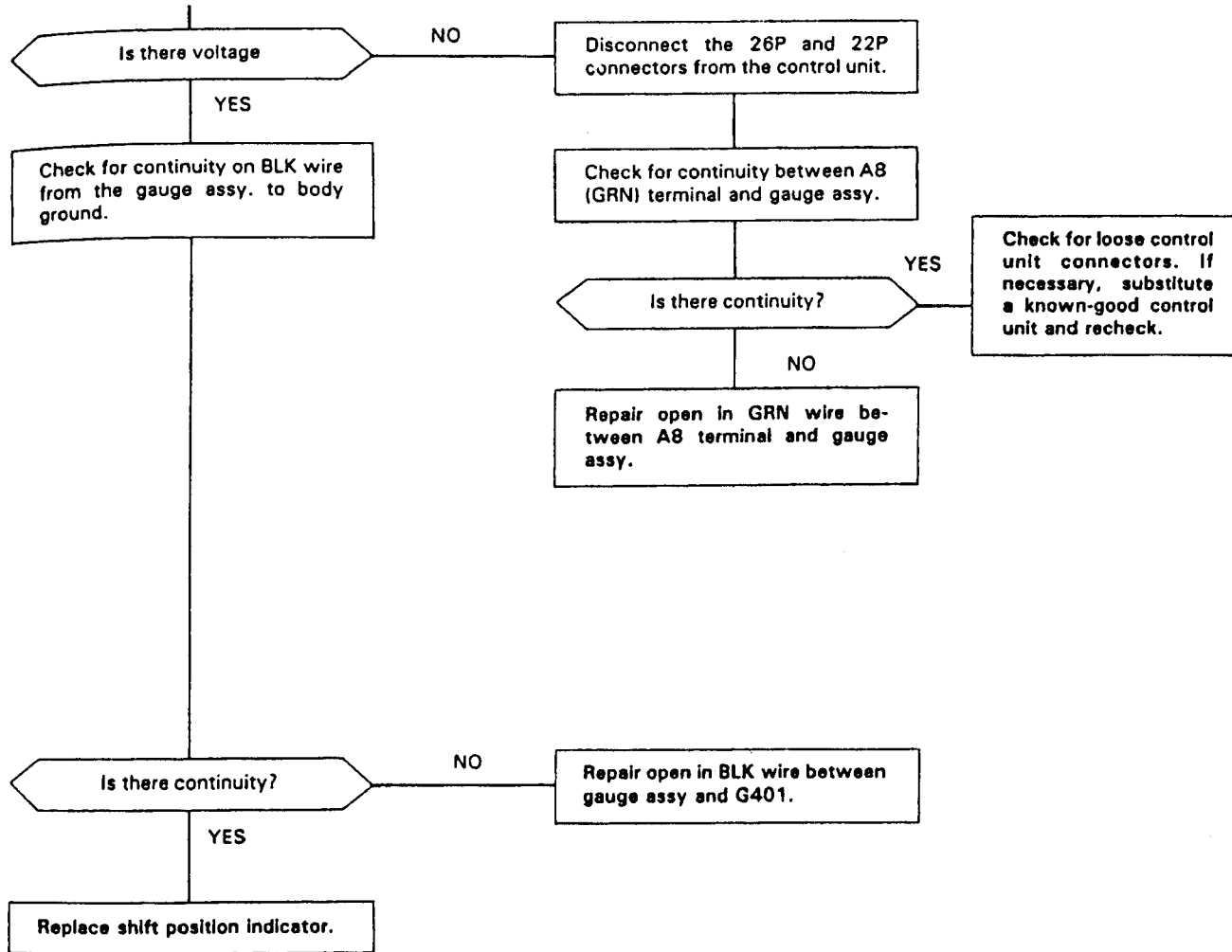



# Technical Service Information

## 1992 ONLY

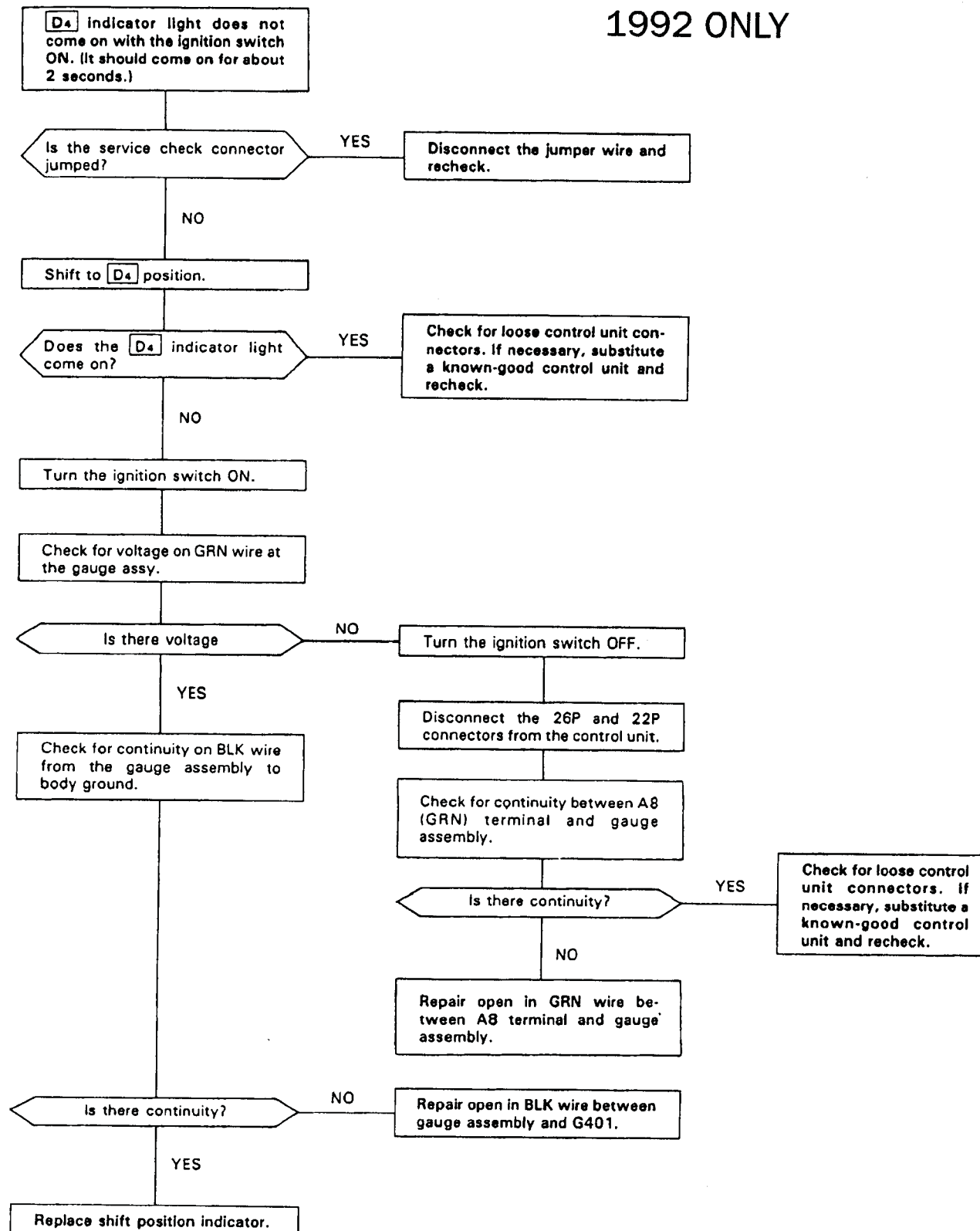

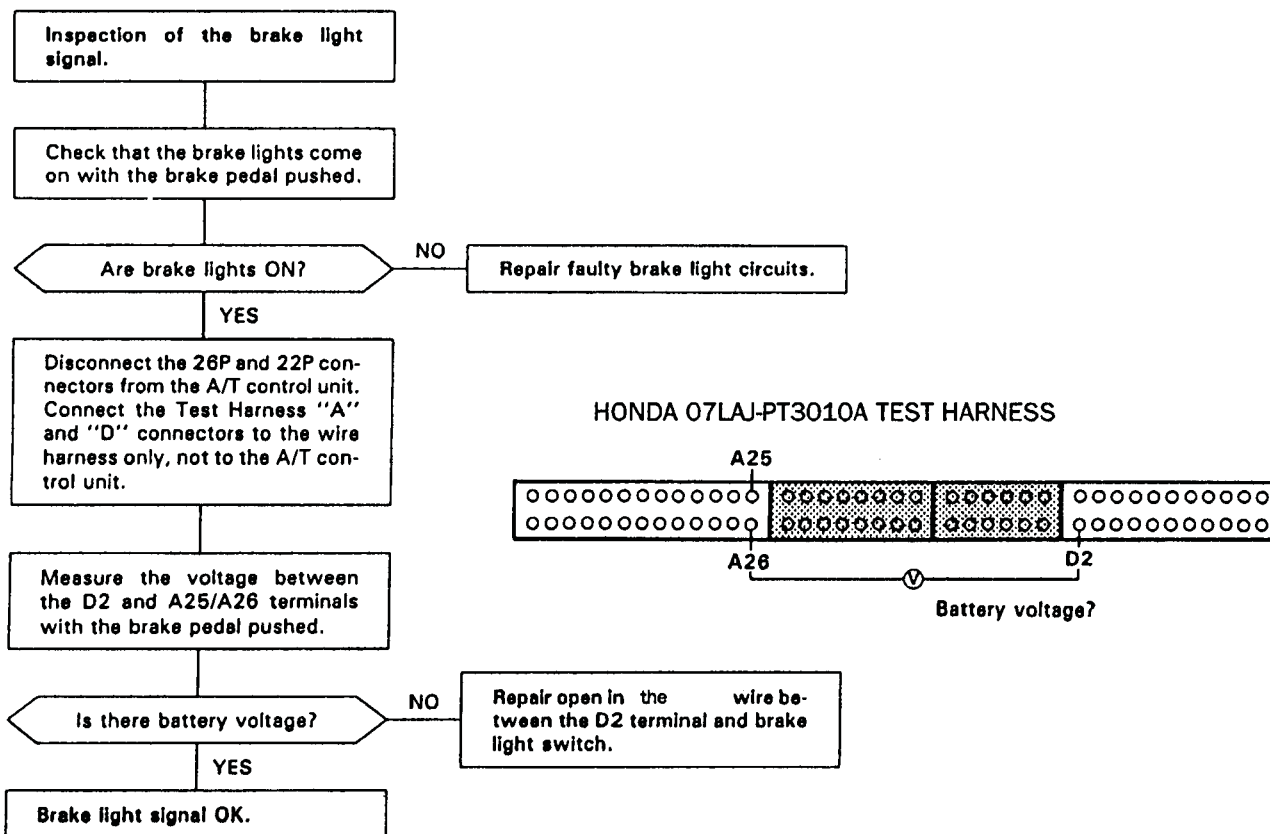





# Technical Service Information

## IDENTIFICATION TAG

**APX4-0000000**

TRANS  
MODEL

TRANSAXLE  
SERIAL NO.

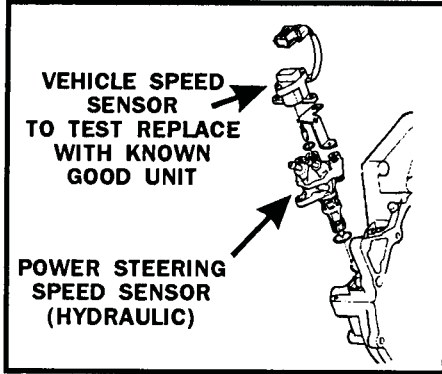

NC SPEED SENSOR CONNECTOR  
400 - 600 OHMS 68°F  
FROM TERMINAL TO TERMINAL

NM SPEED SENSOR CONNECTOR  
400 - 600 OHMS 68°F  
FROM TERMINAL TO TERMINAL

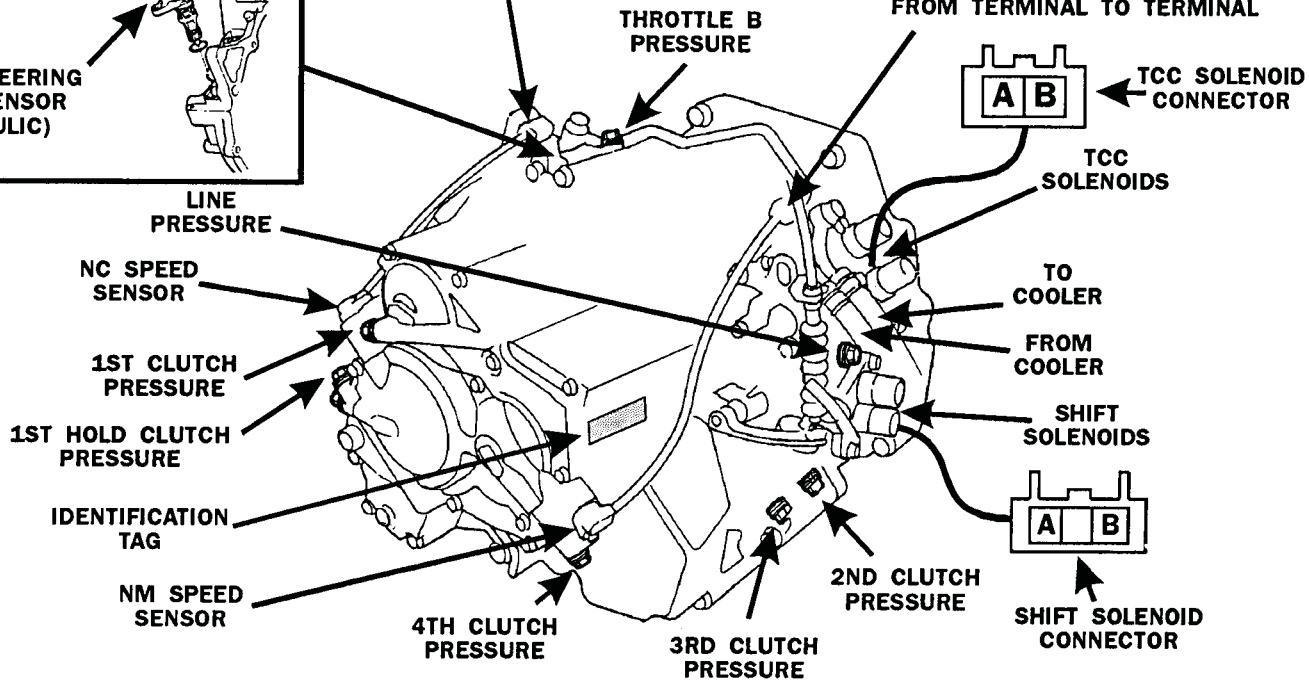

TO ENERGIZE N.C. SHIFT  
SOLENOIDS  
APPLY 12 VOLTS

GEAR	SOLENOID A	SOLENOID B
1		ON
2	ON	ON
3	ON	
4		

TO APPLY TCC  
ENERGIZE BOTH  
N.C. TCC SOLENOIDS  
WITH 12 VOLTS

12 - 24 OHMS  
N.C. SHIFT SOLENOID A TO GROUND  
N.C. SHIFT SOLENOID B TO GROUND

12 - 24 OHMS  
N.C. TCC SOLENOID A TO GROUND  
N.C. TCC SOLENOID B TO GROUND

**PRESSURE PORT FITTINGS  
SIZE 8X1.25 METRIC**



## Technical Service Information

### PRESSURE SPECIFICATIONS 1990 - 1992

PX4B, AP4X, MP1A, AND (MPWA ACCORD ONLY)

SELECTOR POSITION	GEAR	PRESSURE PORT AND CONDITION	PRESSURE IN PSI	
			PX4B-APX4 MPWA-MP1A <sup>2</sup>	MP1A <sup>3</sup>
P	—	LINE PORT AT 2000 RPM <sup>1</sup>	107 - 121	114 - 128
R	R	4TH PORT AT 1000 RPM <sup>1</sup>	107 - 121	114 - 128
R	R	4TH PORT AT W.O.T. STALL <sup>1</sup>	250	250
N	—	LINE PORT AT 2000 RPM <sup>1</sup>	107 - 121	114 - 128
D4	1st	1ST PORT AT 1000 RPM <sup>1</sup>	107 - 121	114 - 128
D4	1st	1ST PORT AT W.O.T. STALL <sup>1</sup>	250	250
D4	1st	THROTTLE B PORT AT IDLE <sup>1</sup>	MUST BE 0	MUST BE 0
D4	1st	THROTTLE B PORT AT 1000 RPM W/TV LEVER UP <sup>1</sup>	107 - 121	114 - 128
D4	2nd	2ND PORT CLOSED THROTTLE	64 - 71	64 - 71
D4	2nd	2ND PORT WITH MORE THAN 1/4 THROTTLE	102 - 121	114 - 128
D4	3rd	3RD PORT CLOSED THROTTLE	64 - 71	64 - 71
D4	3rd	3RD PORT WITH MORE THAN 1/4 THROTTLE	107 - 121	114 - 128
D4	4th	4TH PORT CLOSED THROTTLE	64 - 71	64 - 71
D4	4th	4TH PORT WITH MORE THAN 1/4 THROTTLE	107 - 121	114 - 128
S3 or D3	1st	1ST PORT AT 1000 RPM <sup>1</sup>	107 - 121	114 - 128
S3 or D3	1st	1ST PORT AT W.O.T. STALL <sup>1</sup>	250	250
2	2nd	2ND PORT AT 1000 RPM <sup>1</sup>	107 - 121	114 - 128
1	1st	1ST HOLD PORT AT 1000 RPM <sup>1</sup>	107 - 121	114 - 128

<sup>1</sup> PRESSURE TEST PERFORMED WITH WHEELS OFF THE GROUND AND BRAKES APPLIED.

<sup>2</sup> MP1A WITH F22A SINGLE OVER HEAD CAM ENGINE

<sup>3</sup> MP1A WITH H23A DUAL OVER HEAD CAM ENGINE



# Technical Service Information

## Hydraulic System

SYMPTOM	Check these items on the PROBABLE CAUSE List	Check these items on the NOTES List
Engine runs, but car does not move in any gear.	1, 6, 7, 16	K, L, R, S
Car moves in <b>[R]</b> and <b>[2]</b> , but not in <b>[D3]</b> , <b>[D4]</b> or <b>[1]</b> .	8, 29, 44, 48	C, M, O
Car moves in <b>[D3]</b> , <b>[D4]</b> , <b>[1]</b> , <b>[R]</b> , but not in <b>[2]</b> .	9, 30, 49	C, L
Car moves in <b>[D3]</b> , <b>[D4]</b> , <b>[2]</b> , <b>[1]</b> , but not in <b>[R]</b> .	1, 11, 22, 34, 38, 39, 40	C, L, Q
Car moves in <b>[N]</b> .	1, 8, 9, 10, 11, 46, 47	C, D
Excessive idle vibration.	5, 17	B, K, L
Slips in all gears.	6, 7, 16	C, L, U
No engine braking in <b>[1]</b> position.	12	C, D, L
Slips in low gear.	8, 29, 44, 48	C, N, O, U
Slips in 2nd gear.	9, 20, 23, 30, 49	C, L, U
Slips in 3rd gear.	10, 21, 23, 31, 49	C, L, U
Slips in 4th gear.	11, 23, 32, 44	C, L, N, U
Slips in reverse gear.	11, 32, 34, 44	C, N
Flares on 1–2 upshift.	3, 15, 23	E, L, V
Flares on 2–3 upshift.	3, 15, 23, 24, 49	E, L, V
Flares on 3–4 upshift.	3, 15, 23, 25, 49	E, L, N, V
No upshift; transmission stays in low gear.	14, 19, 23	G, L
No downshift to low gear.	12, 19	G, L
Late upshift.	14	L, V
Erratic shifting.	2, 14, 26	V
Harsh shift (up and down shifting).	2, 4, 15, 23, 24, 25, 26, 27, 47	A, E, H, I, L, V
Harsh shift (1–2).	2, 9, 15, 23	C, D, E, V
Harsh shift (2–3).	2, 10, 15, 23, 24	C, D, E, H, L, V
Harsh shift (3–4).	2, 11, 15, 23, 25	C, D, E, I, L, V
Harsh kick-down shifts.	2, 15, 23, 26, 27, 28	E, L, V, Q
Harsh kick-down shift (2–1).	48	O
Harsh downshift at closed throttle.	2, 15, 23	E, T
Harsh shift when manually shifting to <b>[1]</b> .	33	L
Axle(s) slips out of transmission on turns.	43, 50	L, P, Q
Axle(s) stuck in transmission.	43	L, Q
Ratcheting noise when shifting into <b>[R]</b> .	6, 7, 38, 39, 40	K, L, Q
Loud popping noise when taking off in <b>[R]</b> .	38, 39, 40	L, Q
Ratcheting noise when shifting from <b>[R]</b> to <b>[P]</b> or from <b>[R]</b> to <b>[N]</b> .	38, 39, 40, 45	L, Q
Noise from transmission in all selector lever positions.	6, 17	K, L, Q
Noise from transmission only when wheels are rolling.	39, 42	L, Q
Gear whine, rpm related (pitch changes with shifts).	8, 13, 41	K, L, Q
Gear whine, speed related (pitch changes with speed).	38, 42	L, Q
Transmission will not shift into 4th gear in <b>[D4]</b> .	1, 21, 28, 32	L
Lockup clutch does not lockup smoothly.	17, 36, 37	L
Lockup clutch does not operate properly.	2, 3, 15, 18, 35, 36, 37	E, L, V
Transmission has multitude of problems shifting. At disassembly, large particles of metal are found on magnet.	43	L, Q



## Technical Service Information

PROBABLE CAUSE	
1.	Shift cable broken/out of adjustment.
2.	Throttle cable too short.
3.	Throttle cable too long.
4.	Wrong type ATF.
5.	Idle rpm too low/high.
6.	Oil pump worn or binding.
7.	Pressure regulator stuck.
8.	1st clutch defective.
9.	2nd clutch defective.
10.	3rd clutch defective.
11.	4th clutch defective.
12.	1st-hold clutch defective.
13.	Mainshaft, countershaft, and secondary shaft idler gears worn/damaged.
14.	Modulator valve stuck.
15.	Throttle valve B stuck.
16.	ATF strainer clogged.
17.	Torque converter defective.
18.	Torque converter check valve stuck.
19.	1-2 shift valve stuck.
20.	2-3 shift valve stuck.
21.	3-4 shift valve stuck.
22.	Servo control valve stuck.
23.	Clutch pressure control (CPC) valve stuck.
24.	2nd orifice control valve stuck.
25.	Orifice control valve stuck.
26.	3-2 kick-down valve stuck.
27.	3rd kick-down valve stuck.
28.	4th exhaust valve stuck.
29.	1st accumulator defective.
30.	2nd clutch accumulator defective.
31.	3rd clutch accumulator defective.
32.	4th/reverse accumulator defective.
33.	1st-hold clutch accumulator defective.
34.	Servo valve stuck.
35.	Lockup clutch timing valve stuck.
36.	Lockup clutch shift valve stuck.
37.	Lockup clutch control valve stuck.
38.	Shift fork bent.
39.	Reverse gears worn/damaged (3 gears).
40.	Reverse selector worn.
41.	3rd gears worn/damaged (2 gears).
42.	Final gears worn/damaged (2 gears).
43.	Differential pinion shaft worn.
44.	Feedpipe O-ring broken.
45.	4th gears worn/damaged (2 gears).
46.	Gear clearance incorrect.
47.	Clutch clearance incorrect.
48.	One-way (sprag) clutch defective.
49.	Sealing rings/guide worn.
50.	Axle-inboard joint clip missing.

(cont'd)



# Technical Service Information

## Hydraulic System (cont'd)

The following symptoms can be caused by improper repair or assembly.	Check these items on the PROBABLE CAUSE DUE TO IMPROPER REPAIR List	Items on the NOTES List
Car creeps in [N].	R1, R2	
Car does not move in [D <sub>3</sub> ] or [D <sub>4</sub> ].	R4	
Transmission locks up in [R].	R3, R12	
Excessive drag in transmission.	R6	R, K
Excessive vibration, rpm related.	R7	
Noise with wheels moving only.	R5	
Main seal pops out.	R8	S
Various shifting problems.	R9, R10	
Harsh upshifts.	R11	

PROBABLE CAUSE DUE TO IMPROPER REPAIR	
R1.	Improper clutch clearance.
R2.	Improper gear clearance.
R3.	Parking brake lever installed upside down.
R4.	One-way (sprag) clutch installed upside down.
R5.	Reverse hub installed upside down.
R6.	Oil pump binding.
R7.	Torque converter not fully seated in oil pump.
R8.	Main seal improperly installed.
R9.	Springs improperly installed.
R10.	Valves improperly installed.
R11.	Ball check valves not installed.
R12.	Shift fork bolt not installed.



## Technical Service Information

NOTES	
A.	Flush transmission cooler system
B.	Set idle rpm in gear to specified idle speed. If still no good, adjust motor mounts as outlined in engine section of service manual.
C.	If the large clutch piston O-ring is broken, inspect the piston groove for rough machining.
D.	If the clutch pack is seized or is excessively worn, inspect the other clutches for wear and check the orifice control valves and throttle valves for free movement.
E.	If throttle valve B is stuck, inspect the clutches for wear.
G.	If the 1-2 valve is stuck closed, the transmission will not upshift. If stuck open the transmission has no 1st gear.
H.	If the 2nd orifice control valve is stuck, inspect the 2nd and 3rd clutch packs for wear.
I.	If the orifice control valve is stuck, inspect the 3rd and 4th clutch packs for wear.
J.	If the clutch pressure control valve is stuck closed, the transmission will not shift out of 1st gear.
K.	Improper alignment of main valve body and torque converter housing may cause oil pump seizure. The symptoms are mostly an rpm-related ticking noise or a high pitched squeek.
L.	If the oil screen is clogged with particles of steel or aluminum, inspect the oil pump and differential pinion shaft. If both are OK and no cause for the contamination is found, replace the torque converter.
M.	If the 1st clutch feedpipe guide in the end cover is scored by the mainshaft, inspect the ball bearing for excessive movement in the transmission housing. If OK, replace the end cover as it is dented. The O-ring under the guide is probably worn.
N.	Replace the mainshaft if the bushings for the 1st and 4th feedpipe are loose or damaged. If the 1st feedpipe is damaged or out of round, replace it. If the 4th feedpipe is damaged or out of round, replace the end cover.
O.	A worn or damaged sprag clutch is mostly a result of shifting the trans in <b>[D3]</b> or <b>[D4]</b> while the wheels rotate in reverse, such as rocking the car in snow.
P.	Inspect the frame for collision damage.
Q.	Inspect for damage or wear: 1. Reverse selector gear teeth chamfers. 2. Engagement teeth chamfers of countershaft 4th and reverse gear. 3. Shift fork for scuff marks in center. 4. Differential pinion shaft for wear under pinion gears. 5. Bottom of 3rd clutch for swirl marks. Replace items 1, 2, 3 and 4 if worn or damaged. If trans makes clicking, grinding or whirring noise, also replace mainshaft 4th gear and reverse idler gear and countershaft 4th gear in addition to 1, 2, 3 or 4. If differential pinion shaft is worn, overhaul differential assembly and replace oil screen and thoroughly clean trans, flush torque converter, cooler and lines. If bottom of 3rd clutch is swirled and trans makes gear noise, replace the countershaft and ring gear.
R.	Be very careful not to damage the torque converter housing when replacing the main ball bearing. You may also damage the oil pump when you torque down the main valve body. This will result in oil pump seizure if not detected. Use proper tools.
S.	Install the main seal flush with the torque converter housing. If you push it into the torque converter case until it bottoms out, it will block the oil return passage and result in damage.
T.	Harsh downshifts when coasting to a stop with zero throttle may be caused by a bent-in throttle valve retainer/cam stopper. Throttle cable adjustment may clear this problem.
U.	Check if servo valve stopper cap is installed. If it was not installed, the check valve may have been pushed out by hydraulic pressure causing a leak (internal) affecting all forward gears.
V.	Throttle cable adjustment is essential for proper operation of the transmission. Not only does it affect the shift points if misadjusted, but also the shift quality and lock-up clutch operation. A too long adjusted cable will result in throttle pressure being too low for the amount of engine torque input into the transmission and may cause clutch slippage. A too short adjusted cable will result in too high throttle pressures which may cause harsh shifts, erratic shifts and torque converter hunting.



# Technical Service Information

## ACCORD ROAD TEST

### Gear Selection

The selector lever has seven positions: **P** PARK, **R** REVERSE, **N** NEUTRAL, **D<sub>4</sub>** 1st through 4th gear ranges, **D<sub>3</sub>** 1st through 3rd gear ranges, **2** 2nd gear and **1** 1st gear.

Position	Description
<b>P</b> PARK	Front wheels locked; parking pawl engaged with parking gear on countershaft. All clutches released.
<b>R</b> REVERSE	Reverse; reverse selector engaged with countershaft reverse gear and 4th gear clutch locked.
<b>N</b> NEUTRAL	All clutches released.
<b>D<sub>4</sub></b> DRIVE (1 through 4)	General driving; starts off in 1st, shifts automatically to 2nd, 3rd, then 4th, depending on vehicle speed and throttle position. Downshift through 3rd, 2nd and 1st on deceleration to stop. The lockup mechanism comes into operation in <b>D<sub>4</sub></b> .
<b>D<sub>3</sub></b> DRIVE (1 through 3)	For rapid acceleration at highway speeds and general driving; up-hill and down-hill driving; starts off in 1st, shifts automatically to 2nd, then 3rd, depending on vehicle speed and throttle position. Downshifts through 2nd to 1st on deceleration to stop. The lockup mechanism comes into operation in 3rd speed, for 1992 Prelude only
<b>2</b> SECOND	For engine braking or better traction when starting off on loose or slippery surfaces; stays in 2nd gear, does not shift up or down.
<b>1</b> FIRST	For engine braking; stays in 1st gear, does not shift up or down.

Starting is possible only in **P** and **N** through the use of a slide-type, neutral-safety switch.

### Position Indicator

A position indicator in the instrument panel shows what gear has been selected without having to look down at the console.

NOTE: After transmission is installed:

- Make sure the floor mat does not interfere with accelerator pedal travel. Fully depress accelerator pedal and check to make sure the throttle lever is fully opened.
- Release the accelerator pedal and check both inner control cables to be sure they have slight play.

Warm up the engine to operating temperature.

### **D<sub>4</sub>** and **D<sub>3</sub>** Range

1. Apply parking brake and block the wheels. Start the engine, then move the selector to **D<sub>4</sub>** while depressing the brake pedal. Depress the accelerator pedal, and release it suddenly. Engine should not stall.
2. Check that shift points occur at approximate speeds shown. Also check for abnormal noise and clutch slippage.
3. Apply parking brake and block the wheels. Start the engine, then move the selector to **D<sub>3</sub>** while depressing the brake pedal. Depress the accelerator pedal, and release it suddenly. Engine should not stall.

### • Upshift

<b>D<sub>4</sub></b> and <b>D<sub>3</sub></b>		1st-2nd	2nd-3rd	3rd-4th	Lock up Clutch ON
1/8 throttle Coasting down-hill from a stop	km/h	20.9-24.1	41.8-45.1	57.9-64.4	22.5-27.4
	mph	13-15	26-28	36-40	14-17
1/2 throttle Acceleration from a stop	km/h	27.4-33.8	56.3-62.8	86.9-96.6	96.6-104.6
	mph	17-21	35-39	54-60	60-65
Full-throttle Acceleration from a stop	km/h	48.3-56.3	101.4-109.4	151.3-160.9	135.2-143.2
	mph	30-35	63-68	94-100	84-89

### 1990-91 ONLY

<b>D<sub>4</sub></b> and <b>D<sub>3</sub></b> (with S switch in operation)		1st-2nd	2nd-3rd	3rd-4th	Lock up Clutch ON
1/8 throttle Coasting down-hill from a stop	km/h	17.7-20.9	38.6-41.8	61.2-67.6	37.0-41.8
	mph	11-13	24-26	38-42	23-26
1/2 throttle Acceleration from a stop	km/h	27.4-33.8	66.0-72.4	99.8-109.4	111.0-119.1
	mph	17-21	41-45	62-68	69-74
Full-throttle Acceleration from a stop	km/h	48.3-56.3	101.4-109.4	154.5-164.1	143.2-151.3
	mph	30-35	63-68	96-102	89-94

## PRELUDE ROAD TEST

NOTE: Warm up the engine to operating temperature.

1. Apply parking brake and block the wheels. Start the engine, then move the selector lever to **[D<sub>4</sub>]** position while depressing the brake pedal. Depress the accelerator pedal and release it suddenly. Engine should not stall.
2. Repeat same test in **[D<sub>3</sub>]** position.
3. Shift the selector lever to **[D<sub>4</sub>]** position and check that the shift points occur at approximate speeds shown. Also check for abnormal noise and clutch slippage.

NOTE: Throttle angle sensor voltage represents the throttle opening.

- 1. Connect the Test Harness between the ECU and connector (see page 11-21).
- 2. Set the digital multimeter to check voltage between D11 (+) terminal and D22 (-) terminal for the throttle angle sensor.

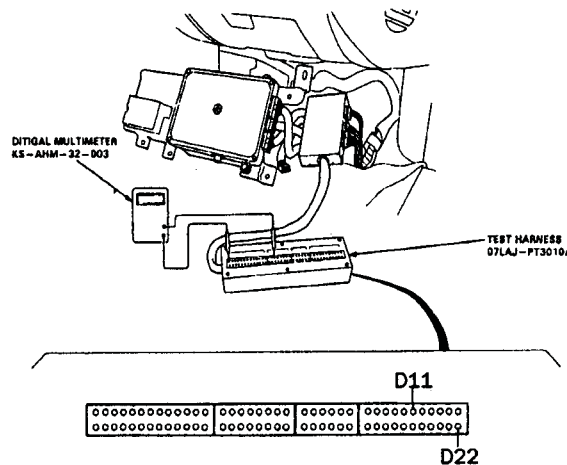

F22A Engine: **[D<sub>4</sub>]** Position

• Upshift

		1st→2nd	2nd→3rd	3rd→4th	Lockup Clutch ON
Throttle angle sensor voltage: 0.83 V Coasting down-hill from a stop	mph	13-15	26-28	36-40	14-17
	km/h	21-24	42-45	58-64	23-27
Throttle angle sensor voltage: 2.18 V Acceleration from a stop	mph	17-21	37-41	57-63	61-67
	km/h	27-34	60-66	92-101	98-108
Full-throttle Acceleration from a stop	mph	29-34	60-65	88-94	81-86
	km/h	47-55	97-105	142-151	130-138

• Downshift

		Lockup Clutch OFF	4th→3rd	3rd→2nd	2nd→1st
Throttle angle sensor voltage: 0.83 V Coasting or braking to a stop	mph	13-16	—	18-22 (4th→2nd)	6-10
	km/h	21-26	—	29-35 (4th→2nd)	10-16
Throttle angle sensor voltage: 2.18 V When car is slowed by increased grade, wind, etc.	mph	53-59	—	—	—
	km/h	85-95	—	—	—
Full-throttle When car is slowed by increased grade, wind, etc.	mph	77-82	76-82	52-57	21-26
	km/h	124-132	123-132	84-92	34-42



# Technical Service Information

## PRELUDE ROAD TEST

H23A Engine: **D4** Position

• Upshift

		1st→2nd	2nd→3rd	3rd→4th	Lockup Clutch ON
Throttle angle sensor voltage: 0.83 V Coasting down-hill from a stop	mph	13–15	26–28	36–40	14–17
	km/h	21–24	42–45	58–64	23–27
Throttle angle sensor voltage: 2.18 V Acceleration from a stop	mph	18–22	36–40	54–60	58–64
	km/h	29–35	58–64	87–97	93–103
Full-throttle Acceleration from a stop	mph	29–34	57–62	83–88	80–85
	km/h	47–55	92–100	134–142	129–137

• Downshift

		Lockup Clutch OFF	4th→3rd	3rd→2nd	2nd→1st
Throttle angle sensor voltage: 0.83 V Coasting or braking to a stop	mph	13–16	—	18–22 (4th→2nd)	6–10
	km/h	21–26	—	29–35 (4th→2nd)	10–16
Throttle angle sensor voltage: 2.18 V When car is slowed by increased grade, wind, etc.	mph	48–54	—	—	—
	km/h	77–87	—	—	—
Full-throttle When car is slowed by increased grade, wind, etc.	mph	73–80	73–79	51–56	24–29
	km/h	117–129	117–127	82–90	39–47

4. Accelerate to about 35 mph (57 km/h) so the transmission is in 4th, then shift **D4** to **2**. The car should immediately begin slowing down from engine braking.

**CAUTION:** Do not shift from **D4** or **D3** to **2** or **1** at speeds over 62.5 mph (100 km/h); you may damage the transmission.

5. Check for abnormal noise and clutch slippage in the following positions.

**1** (1st Gear) Position

- 1. Accelerate from a stop at full throttle. Check that there is no abnormal noise or clutch slippage.
- 2. Upshifts and downshifts should not occur with the selector in this position.

**2** (2nd Gear) Position

- 1. Accelerate from a stop at full throttle. Check that there is no abnormal noise or clutch slippage.
- 2. Upshifts and downshifts should not occur with the selector in this position.

**R** (Reverse) Position

Accelerate from a stop at full throttle, and check for abnormal noise and clutch slippage.

6. Test in **P** (Parking) Position

Park car on slope (approx. 16°), apply the parking brake, and shift into **P** position. Release the brake; the car should not move.



## Stall Speed

### CAUTION:

- To prevent transmission damage, do not test stall speed for more than 10 seconds at a time.
- Do not shift the lever while raising the engine speed.
- Be sure to remove the pressure gauge before testing stall speed.

1. Engage parking brake and block the front wheels.
2. Connect tachometer, and start the engine.
3. Push the A/C switch OFF.
4. After the engine has warmed up to normal operating temperature, shift into **[2]**.
5. Fully depress the brake pedal and accelerator for 6 to 8 seconds, and note engine speed.
6. Allow 2 minutes for cooling, then repeat same test in **[D<sub>4</sub>]**, **[1]**, and **[R]**.

Stall speed in **[D<sub>4</sub>]**, **[2]**, **[1]** and **[R]** must be the same, and must also be within limits:

### NOTE:

Stall speed test must be made only for checking the cause of trouble.

### Stall Speed RPM:

**F22A Engine**

Service Limit: 2,350–2,650 rpm

**H23A Engine**

Service Limit: 2,600–2,900 rpm

TROUBLE	PROBABLE CAUSE
Stall rpm high in <b>[D<sub>4</sub>]</b> , <b>[2]</b> , <b>[1]</b> & <b>[R]</b>	<ul style="list-style-type: none"><li>• Low fluid level or oil pump output</li><li>• Clogged oil strainer</li><li>• Pressure regulator valve stuck closed</li><li>• Slipping clutch</li></ul>
Stall rpm high in <b>[R]</b>	<ul style="list-style-type: none"><li>• Slippage of 4th clutch</li></ul>
Stall rpm high in <b>[2]</b> , <b>[D<sub>4</sub>]</b>	<ul style="list-style-type: none"><li>• Slippage of 2nd clutch</li></ul>
Stall rpm high in <b>[1]</b>	<ul style="list-style-type: none"><li>• Slippage of 1st clutch or 1st gear one-way clutch</li></ul>
Stall rpm low in <b>[D<sub>4</sub>]</b> , <b>[2]</b> , <b>[1]</b> & <b>[R]</b>	<ul style="list-style-type: none"><li>• Engine output low</li><li>• Torque converter one-way clutch slipping</li></ul>

## Checking

**NOTE:** Check the fluid level with the engine at normal operating temperature.

1. Park the car on level ground. Turn off the engine.
2. Remove the dipstick (yellow loop) from the transmission, and wipe it with a clean cloth.
3. Insert the dipstick into the transmission.

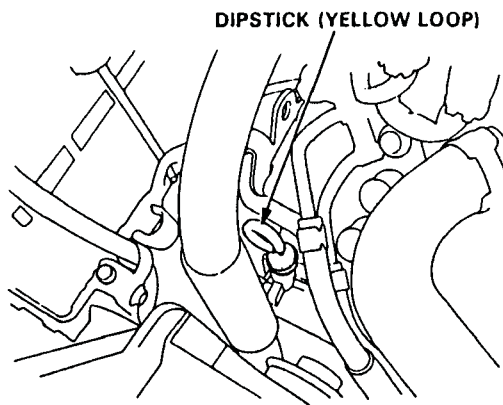

4. Remove the dipstick, and check the fluid level. It should be between the upper and lower marks.

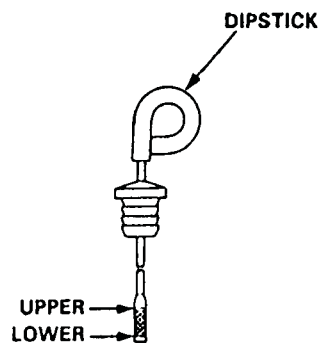

5. If the level is below the lower mark, add fluid into the tube to bring it to the upper mark. Use Honda Premium Formula Automatic Transmission Fluid or an equivalent DEXRON® II Automatic Transmission Fluid (ATF) only.

6. Insert the dipstick back into the transmission.

## Changing

1. Bring the transmission up to operating temperature by driving the car. Park the car on level ground, turn the engine off, and then remove the drain plug.
2. Reinstall the drain plug with a new washer, then refill the transmission to the upper mark on the dipstick.

### Automatic Transmission Capacity:

- 2.4ℓ (2.5 US qts., 2.1 Imp. qt) at change
- 6.0ℓ (6.3 US qts., 5.3 Imp. qt) after overhaul

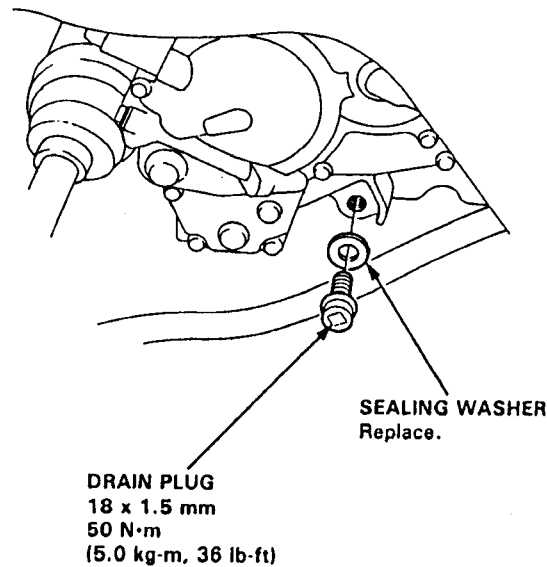

**CAUTION DO NOT REUSE NUT AND WASHERS  
NUMBERED 22, 23, 30, 31, 33, AND 34**

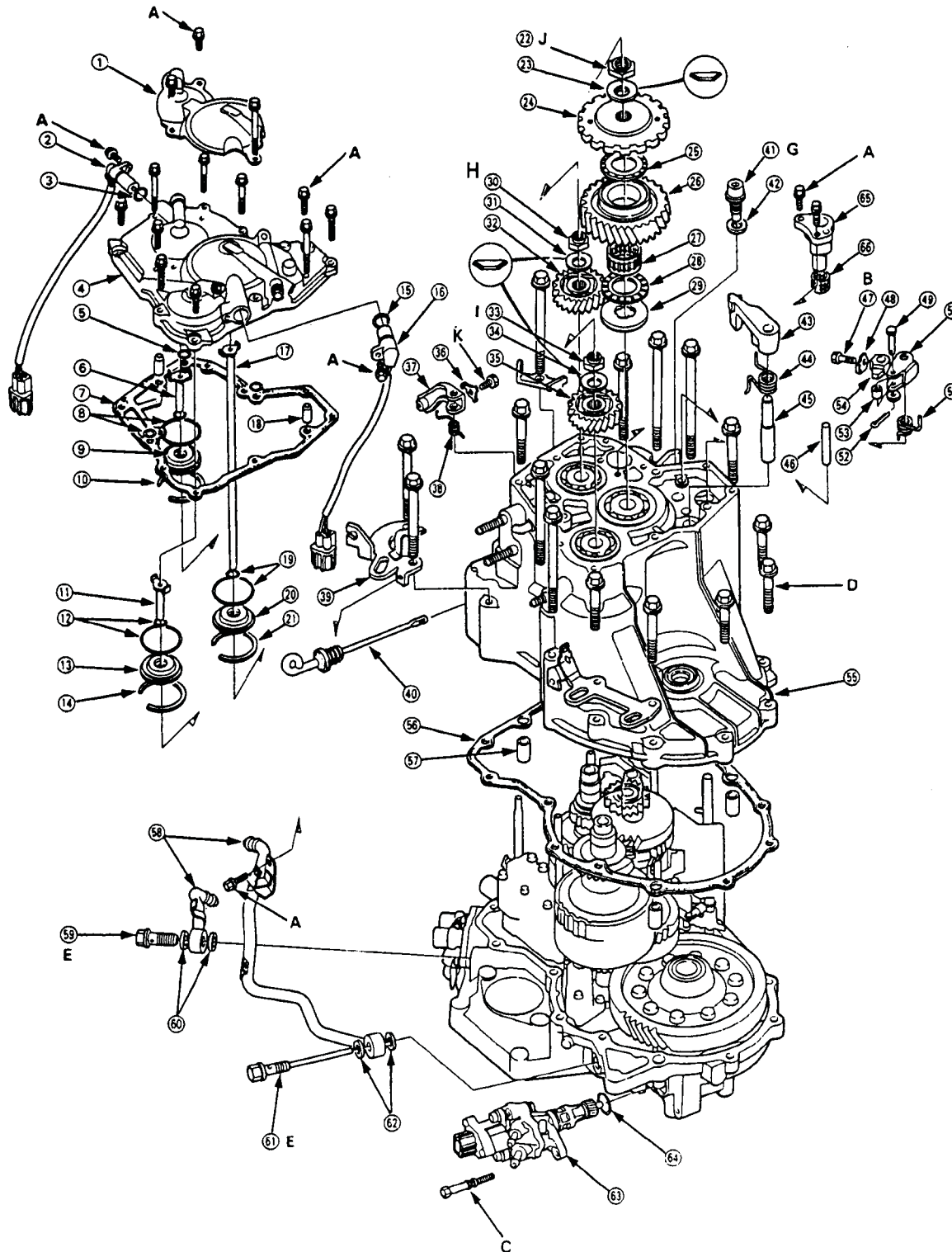



# Technical Service Information

- |                                                                                                                                                                                                                                                                                                                                                                                                                                                                                                                                                                                                                                                                                                                                                                                                                                                                                                                                                                                                                                                                                                                                      |                                                                                                                                                                                                                                                                                                                                                                                                                                                                                                                                                                                                                                                                                                                                                                                                                                                                                                                                                                                                                                                                                                                                                                                                       |
|--------------------------------------------------------------------------------------------------------------------------------------------------------------------------------------------------------------------------------------------------------------------------------------------------------------------------------------------------------------------------------------------------------------------------------------------------------------------------------------------------------------------------------------------------------------------------------------------------------------------------------------------------------------------------------------------------------------------------------------------------------------------------------------------------------------------------------------------------------------------------------------------------------------------------------------------------------------------------------------------------------------------------------------------------------------------------------------------------------------------------------------|-------------------------------------------------------------------------------------------------------------------------------------------------------------------------------------------------------------------------------------------------------------------------------------------------------------------------------------------------------------------------------------------------------------------------------------------------------------------------------------------------------------------------------------------------------------------------------------------------------------------------------------------------------------------------------------------------------------------------------------------------------------------------------------------------------------------------------------------------------------------------------------------------------------------------------------------------------------------------------------------------------------------------------------------------------------------------------------------------------------------------------------------------------------------------------------------------------|
| <ul style="list-style-type: none"> <li>① R. SIDE COVER PROTECTOR</li> <li>② NM SPEED SENSOR</li> <li>③ O-RING Replace.</li> <li>④ R. SIDE COVER</li> <li>⑤ O-RING Replace.</li> <li>⑥ 4TH CLUTCH FEED PIPE</li> <li>⑦ R. SIDE COVER GASKET Replace.</li> <li>⑧ O-RINGS Replace.</li> <li>⑨ FEED PIPE GUIDE</li> <li>⑩ SNAP RING</li> <li>⑪ 1ST CLUTCH FEED PIPE</li> <li>⑫ O-RINGS Replace.</li> <li>⑬ FEED PIPE GUIDE</li> <li>⑭ SNAP RING</li> <li>⑮ O-RING Replace.</li> <li>⑯ NC SPEED SENSOR</li> <li>⑰ 1ST-HOLD CLUTCH FEED PIPE</li> <li>⑱ DOWEL PIN</li> <li>⑲ O-RINGS Replace.</li> <li>⑳ FEED PIPE GUIDE</li> <li>㉑ SNAP RING</li> <li>㉒ COUNTERSHAFT LOCKNUT, 24 × 1.25 mm<br/>(Flange nut) Replace.</li> <li>㉓ CONICAL SPRING WASHER Replace.</li> <li>㉔ PARKING GEAR</li> <li>㉕ THRUST NEEDLE BEARING</li> <li>㉖ COUNTERSHAFT IDLER GEAR</li> <li>㉗ NEEDLE BEARING</li> <li>㉘ THRUST NEEDLE BEARING</li> <li>㉙ THRUST WASHER</li> <li>㉚ MAINSHAFT LOCKNUT, 24 × 1.25 mm<br/>(Flange nut) Replace.</li> <li>NOTE: Left-hand threads</li> <li>㉛ CONICAL SPRING WASHER Replace.</li> <li>㉜ MAINSHAFT IDLER GEAR</li> </ul> | <ul style="list-style-type: none"> <li>㉝ SECONDARY SHAFT LOCKNUT, 24 × 1.25 mm<br/>(Flange nut) Replace.</li> <li>㉞ CONICAL SPRING WASHER Replace.</li> <li>㉟ SECONDARY SHAFT IDLER GEAR</li> <li>㊱ LOCK WASHER Replace.</li> <li>㊲ THROTTLE CONTROL LEVER</li> <li>㊳ THROTTLE CONTROL LEVER SPRING</li> <li>㊴ TRANSMISSION HANGER</li> <li>㊵ ATF LEVEL GAUGE</li> <li>㊶ DRAIN PLUG</li> <li>㊷ SEALING WASHER Replace.</li> <li>㊸ PARKING BRAKE PAWL</li> <li>㊹ PARKING BRAKE PAWL SPRING</li> <li>㊺ PARKING BRAKE PAWL STOPPER</li> <li>㊻ PARKING BRAKE PAWL SHAFT</li> <li>㊼ LOCK BOLT</li> <li>㊽ LOCK WASHER Replace.</li> <li>㊾ ROLLER PIN</li> <li>㊿ PARKING BRAKE LEVER</li> <li>① PARKING BRAKE SPRING</li> <li>② COTTER PIN Replace.</li> <li>③ PARKING BRAKE ROLLER</li> <li>④ PARKING BRAKE STOPPER</li> <li>⑤ TRANSMISSION HOUSING</li> <li>⑥ TRANSMISSION HOUSING GASKET Replace.</li> <li>⑦ DOWEL PIN</li> <li>⑧ ATF COLLER PIPES</li> <li>⑨ JOINT BOLT</li> <li>⑩ SEALING WASHERS Replace.</li> <li>⑪ JOINT BOLT</li> <li>⑫ SEALING WASHERS Replace.</li> <li>⑬ SPEED SENSOR</li> <li>⑭ O-RING Replace.</li> <li>⑮ REVERSE IDLER GEAR SHAFT HOLDER</li> <li>⑯ NEEDLE BEARING</li> </ul> |
|--------------------------------------------------------------------------------------------------------------------------------------------------------------------------------------------------------------------------------------------------------------------------------------------------------------------------------------------------------------------------------------------------------------------------------------------------------------------------------------------------------------------------------------------------------------------------------------------------------------------------------------------------------------------------------------------------------------------------------------------------------------------------------------------------------------------------------------------------------------------------------------------------------------------------------------------------------------------------------------------------------------------------------------------------------------------------------------------------------------------------------------|-------------------------------------------------------------------------------------------------------------------------------------------------------------------------------------------------------------------------------------------------------------------------------------------------------------------------------------------------------------------------------------------------------------------------------------------------------------------------------------------------------------------------------------------------------------------------------------------------------------------------------------------------------------------------------------------------------------------------------------------------------------------------------------------------------------------------------------------------------------------------------------------------------------------------------------------------------------------------------------------------------------------------------------------------------------------------------------------------------------------------------------------------------------------------------------------------------|

## TORQUE SPECIFICATIONS

Ref No.	Torque Value	Bolt Size	Remarks
A	12 N·m (1.2 kg-m, 9 lb-ft)	6 × 1.0 mm	
B	14 N·m (1.4 kg-m, 10 lb-ft)	6 × 1.0 mm	
C	18 N·m (1.8 kg-m, 13 lb-ft)	8 × 1.25 mm	
D	55 N·m (5.5 kg-m, 40 lb-ft)	10 × 1.25 mm	
E	29 N·m (2.9 kg-m, 21 lb-ft)	12 × 1.25 mm	Joint Bolt
G	50 N·m (5.0 kg-m, 36 lb-ft)	18 × 1.5 mm	Drain Plug
H	230 → 0 → 170 N·m (23.0 → 0 → 17.0 kg-m, 166 → 0 → 123 lb-ft)	24 × 1.25 mm	Mainshaft Locknut
I	230 → 0 → 170 N·mm (23.0 → 0 → 17.0 kg-m, 166 → 0 → 123 lb-ft)	24 × 1.25 mm	Left-hand threads Secondary Shaft Locknut
J	230 → 0 → 170 N·mm (23.0 → 0 → 17.0 kg-m, 166 → 0 → 123 lb-ft)	24 × 1.25 mm	Countershaft Locknut
K	8 N·m (0.8 kg-m, 6 lb-ft)	5 × 0.8 mm	



1992

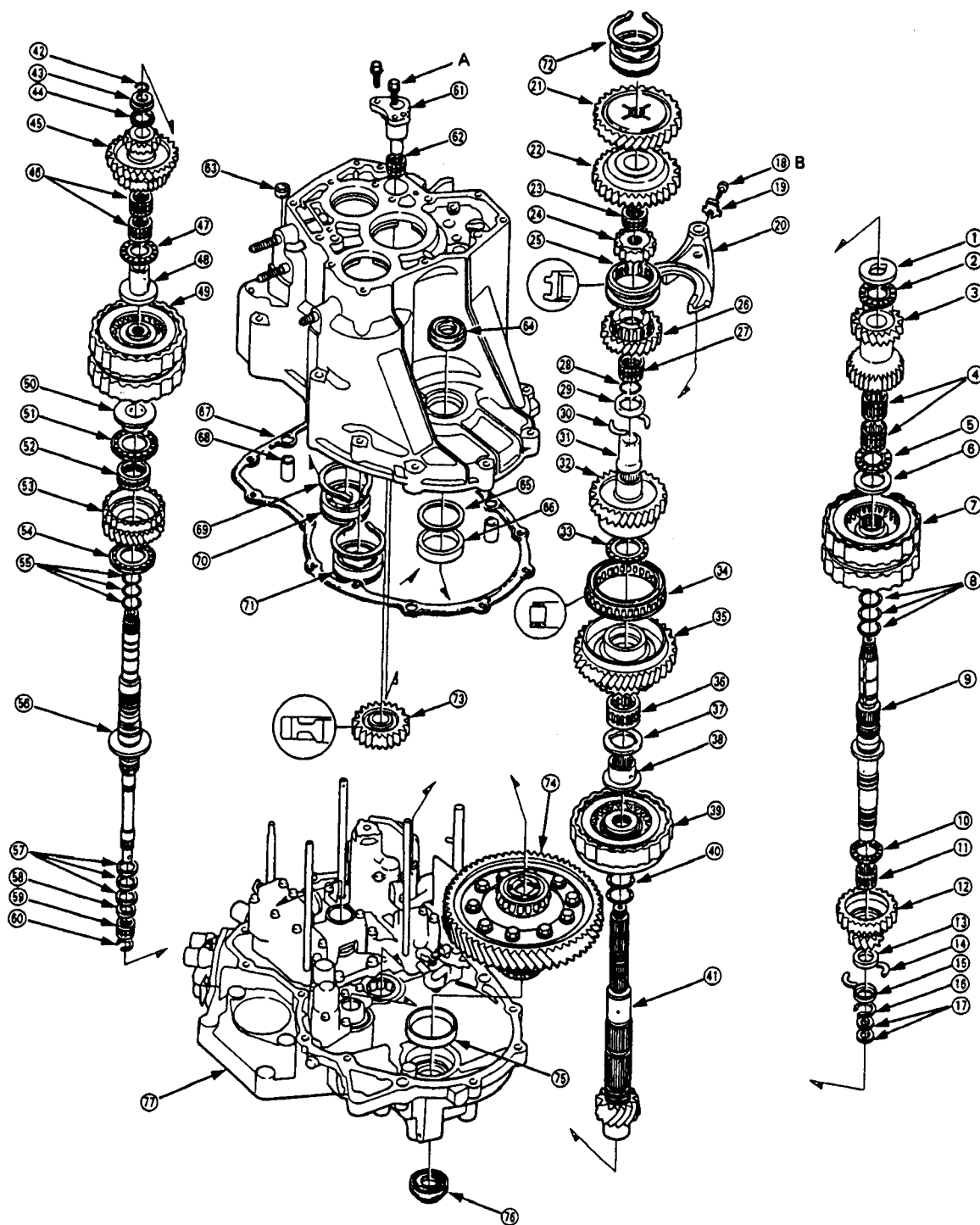



# Technical Service Information

- ① THRUST WASHER
- ② THRUST NEEDLE BEARING
- ③ SECONDARY SHAFT 2ND GEAR
- ④ NEEDLE BEARING
- ⑥ THRUST NEEDLE BEARING
- ⑧ SPLINED WASHER Select part
- ⑦ 1ST/2ND CLUTCH ASSEMBLY
- ⑧ O-RINGS Replace.
- ⑨ SECONDARY SHAFT
- ⑩ THRUST NEEDLE BEARING
- ⑪ NEEDLE BEARING
- ⑫ SECONDARY SHAFT 1ST GEAR
- ⑬ DISTANCE COLLAR, 5.0 mm
- ⑭ COLLAR , 29 mm
- ⑮ COLLAR RETAINER
- ⑯ SNAP RING
- ⑰ SEALING RINGS, 32 mm
- ⑱ LOCK BOLT
- ⑲ LOCK WASHER Replace.
- ⑳ SHIFT FORK
- ㉑ COUNTERSHAFT 2ND GEAR
- ㉒ COUNTERSHAFT REVERSE GEAR
- ㉓ NEEDLE BEARING
- ㉔ REVERSE SELECTOR HUB
- ㉕ REVERSE SELECTOR
- ㉖ COUNTERSHAFT 4TH GEAR
- ㉗ NEEDLE BEARING
- ㉘ SNAP RING
- ㉙ COLLAR, 32 mm
- ㉚ COLLAR , 29 mm
- ㉛ DISTANCE COLLAR
- ㉜ COUNTERSHAFT 3RD GEAR
- ㉝ THRUST NEEDLE BEARING
- ㉞ ONE-WAY CLUTCH
- ㉟ COUNTERSHAFT 1ST GEAR
- ㊱ NEEDLE BEARING
- ㊲ THRUST WASHER
- ㊳ COUNTERSHAFT 3RD GEAR COLLAR
- ㊴ 1ST-HOLD CLUTCH ASSEMBLY
- ㊵ O-RINGS Replace.
- ㊶ COUNTERSHAFT
- ㊷ SNAP RING
- ㊸ COLLAR
- ㊹ THRUST NEEDLE BEARING
- ㊺ MAINSHAFT 4TH/REVERSE GEAR
- ㊻ NEEDLE BEARINGS
- ㊼ THRUST NEEDLE BEARING
- ㊽ 4TH GEAR COLLAR
- ㊾ 3RD/4TH CLUTCH ASSEMBLY
- ㊿ 3RD GEAR COLLAR
- ① THRUST NEEDLE BEARING
- ② NEEDLE BEARING
- ③ MAINSHAFT 3RD GEAR
- ④ THRUST NEEDLE BEARING
- ⑤ O-RINGS Replace.
- ⑥ MAINSHAFT
- ⑦ SEALING RINGS, 35 mm
- ⑧ SEALING RING, 29 mm
- ⑨ NEEDLE BEARING
- ⑩ SET RING
- ⑪ REVERSE IDLER GEAR SHAFT HOLDER
- ⑫ NEEDLE BEARING
- ⑬ OIL SEAL Replace.
- ⑭ TRANSMISSION HOUSING OIL SEAL Replace.
- ⑮ THRUST SHIM Selective part
- ⑯ BEARING OUTER RACE
- ⑰ TRANSMISSION HOUSING GASKET Replace.
- ⑱ DOWEL PIN
- ⑲ SNAP RING
- ㉑ TRANSMISSION HOUSING MAINSHAFT BEARING
- ㉒ TRANSMISSION HOUSING SECONDARY SHAFT BEARING
- ㉓ TRANSMISSION HOUSING COUNTERSHAFT BEARING
- ㉔ REVERSE IDLER GEAR
- ㉕ DIFFERENTIAL ASSEMBLY
- ㉖ BEARING OUTER RACE
- ㉗ TORQUE CONVERTER HOUSING OIL SEAL Replace.
- ㉘ TORQUE CONVERTER HOUSING

## TORQUE SPECIFICATIONS

Ref No.	Torque Value	Bolt Size	Remarks
A	12 N·m (1.2 kg-m, 9 lb-ft)	6 × 1.0 mm	
B	14 N·m (1.4 kg-m, 10 lb-ft)	6 × 1.0 mm	

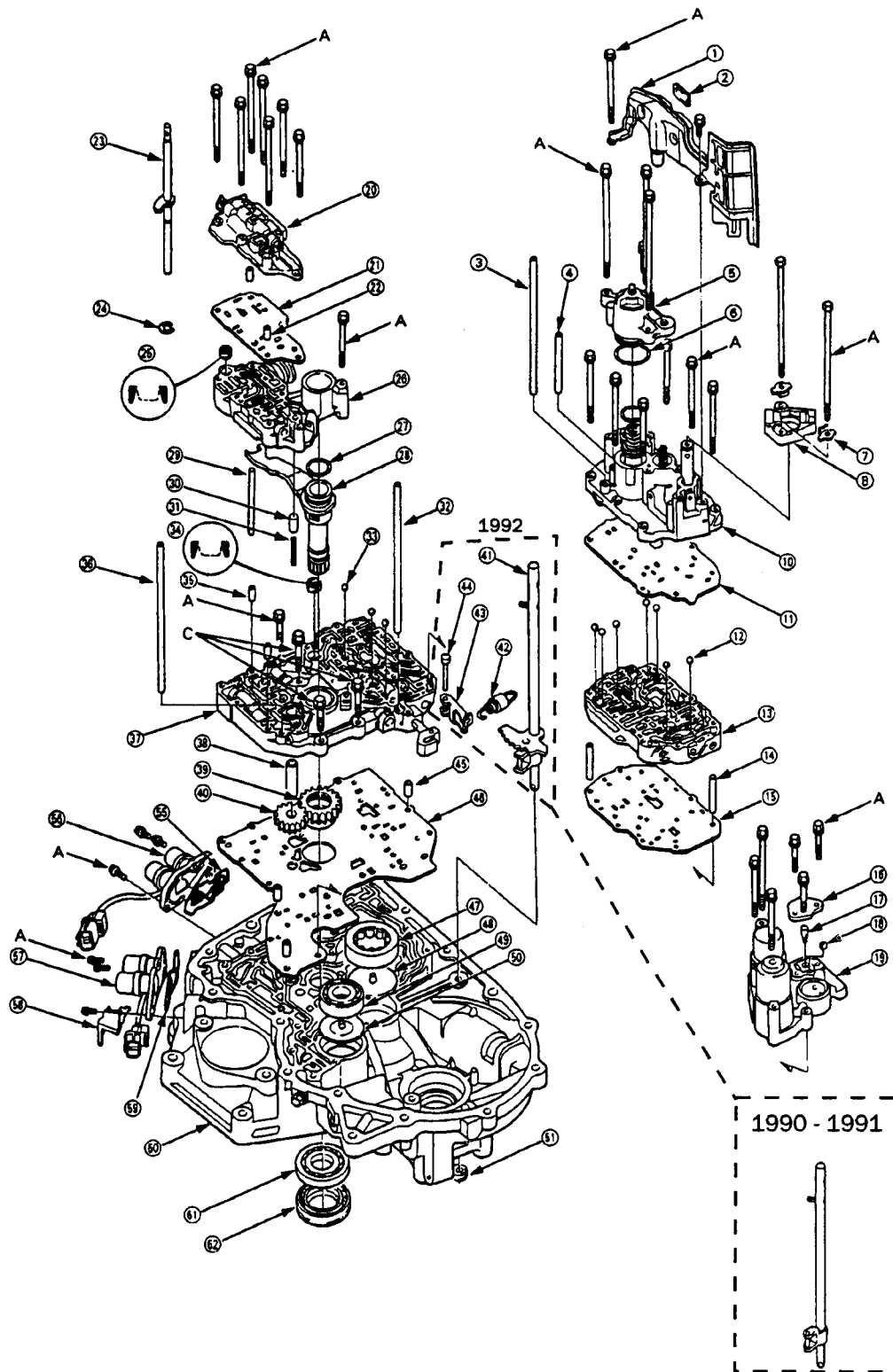



# Technical Service Information

- ① ATF STRAINER
- ② MAGNET
- ③ OIL FEED PIPE
- ④ OIL FEED PIPE
- ⑤ 4TH ACCUMULATOR COVER
- ⑥ O-RING Replace.
- ⑦ LOCK WASHER Replace.
- ⑧ SERVO DETENT BASE
- ⑨ DOWEL PIN
- ⑩ SERVO BODY
- ⑪ SERVO SEPARATOR PLATE
- ⑫ CHECK BALL
- ⑬ SECONDARY VALVE BODY
- ⑭ SECONDARY SEPARATOR PLATE
- ⑮ ACCUMULATOR BODY COVER
- ⑯ 1ST ACCUMULATOR CHOKE
- ⑰ STEEL BALL
- ⑱ 1ST/2ND ACCUMULATOR BODY
- ⑲ THROTTLE VALVE BODY
- ⑳ THROTTLE SEPARATOR PLATE
- ㉑ DOWEL PIN
- ㉒ THROTTLE CONTROL SHAFT
- ㉓ E RING Replace.
- ㉔ FILTER Replace.
- ㉕ REGULATOR VALVE BODY
- ㉖ O-RING Replace.
- ㉗ STATOR SHAFT
- ㉘ STOPPER SHAFT
- ㉙ TORQUE CONVERTER CHECK VALVE
- ㉚ TORQUE CONVERTER CHECK VALVE SPRING

- ㉛ OIL FEED PIPE
- ㉜ CHECK BALL
- ㉝ FILTER Replace.
- ㉞ DOWEL PIN
- ㉟ OIL FEED PIPE
- ㊱ MAIN VALVE BODY
- ㊲ OIL PUMP DRIVEN GEAR SHAFT
- ㊳ OIL PUMP DRIVE GEAR
- ㊴ OIL PUMP DRIVEN GEAR
- ㊵ CONTROL SHAFT
- ㊶ DETENT SPRING
- ㊷ DETENT ARM
- ㊸ DETENT ARM SHAFT
- ㊹ DOWEL PIN
- ㊺ MAIN SEPARATOR PLATE
- ㊻ COUNTERSHAFT NEEDLE BEARING
- ㊼ OIL GUIDE PLATE Replace.
- ㊽ SECONDARY SHAFT BALL BEARING
- ㊾ OIL GUIDE PLATE Replace.
- ㊿ OIL SEAL Replace.
- ①① SHIFT CONTROL SOLENOID FILTER/GASKET Replace.
- ①② SHIFT CONTROL SOLENOID VALVE ASSEMBLY
- ①③ LOCK-UP CONTROL SOLENOID VALVE ASSEMBLY
- ①④ CONECTOR HOLDER
- ①⑤ LOCK-UP CONTROL SOLENOID FILTER/GASKET Replace.
- ①⑥ TORQUE CONVERTER HOUSING
- ①⑦ MAINSHAFT BALL BEARING
- ①⑧ OIL SEAL Replace.

## TORQUE SPECIFICATIONS

Ref No.	Torque Value	Bolt Size	Remarks
A	12 N·m (1.2 kg·m, 9 lb-ft)	6 × 1.0 mm	
C	18 N·m (1.8 kg·m, 13 lb-ft)	8 × 1.25 mm	

## Removal

### Right Side Cover

**NOTE:**

- Clean all parts thoroughly in solvent or carburetor cleaner and dry with compressed air.
- Blow out all passages.
- When removing the transmission R. side cover, replace the following:
  - Right side cover gasket
  - Lock washers
  - Transmission housing gasket
  - O-rings
  - Each shaft locknut and conical spring washer
  - Sealing washers

1. Remove the 11 bolts securing the right side cover, then remove the cover.

**NOTE:** It is not necessary to remove the right side cover protector.

2. Slip the special tool onto the mainshaft.

**MAINSHAFT HOLDER**  
07GAB-PF50100 or  
07GAB-PF50101

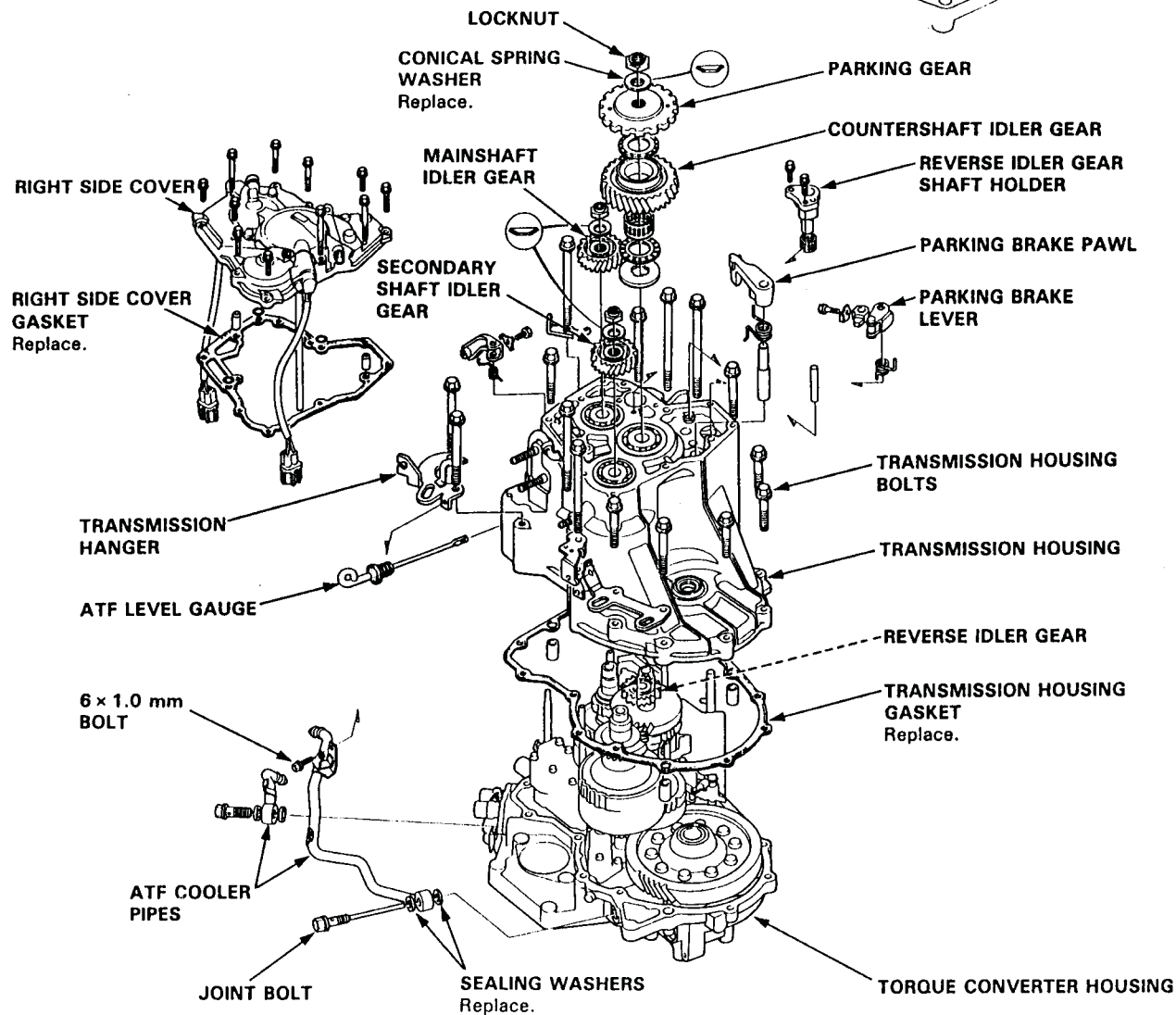
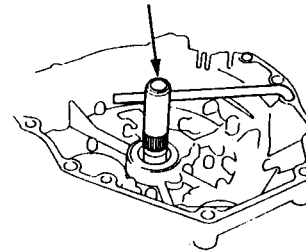

3. Engage the parking brake pawl with the parking gear.
4. Cut the lock tabs of the each shaft locknut using a chisel as shown. Then remove the locknuts and conical spring washers from each shaft.

**NOTE:**

- Mainshaft locknut has left-hand threads.
- Clean the old locknuts and conical spring washers, they are used when installing to press the idler gears on the mainshaft and secondary shaft and the parking gear on the countershaft.

**CAUTION:** Keep all of the chiseled particles out of the transmission.

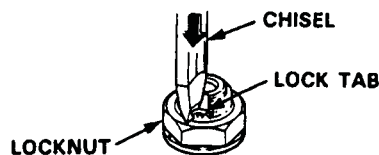

5. Remove the special tool from the mainshaft after removing the locknuts.
6. Remove the parking gear from the counter shaft using a gear puller. Remove the idler gears from the main shaft and secondary shaft using a gear puller.

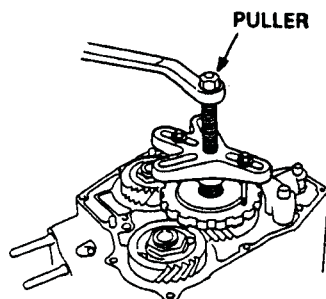

7. Remove the countershaft idler gear, needle bearing, thrust needle bearing, and thrust washer from the countershaft.
8. Remove the parking brake pawl, spring, shaft, and stopper from the housing.
9. Remove the throttle control lever and spring from the throttle control shaft.
10. Remove the ATF cooler pipe mounting bolt from the transmission hanger.
11. Remove the transmission housing mounting bolts.

12. Remove the reverse idler gear shaft assembly.

**NOTE:** The steel ball will not pop out because it is staked in the shaft.

13. Move the reverse idler gear to disengage from the countershaft reverse gear as shown.

**NOTE:** The transmission housing will not separate from the torque converter housing if the reverse idler gear is not removed.

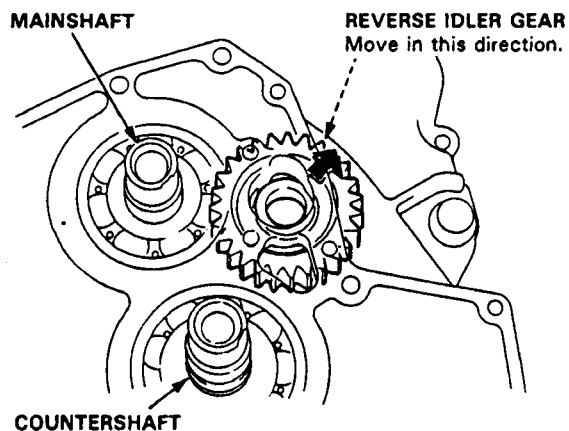

14. Align the spring pin with the transmission housing groove by turning the control shaft.
15. Install the special tool on the transmission housing, then remove the housing as shown.

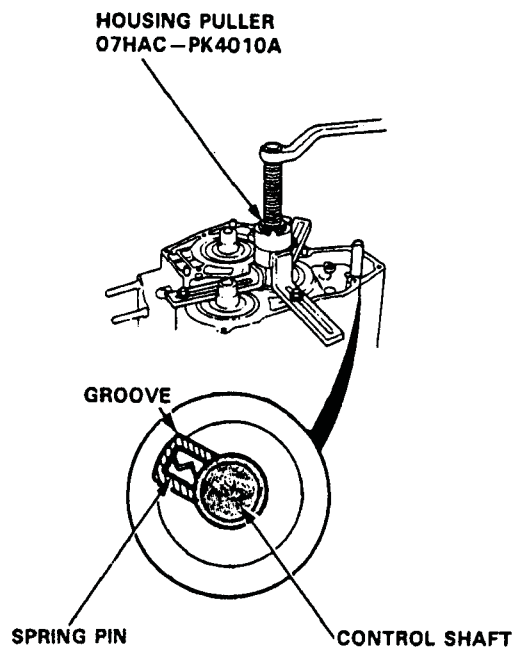

## REMOVAL - TRANSMISSION HOUSING

### 1990-91

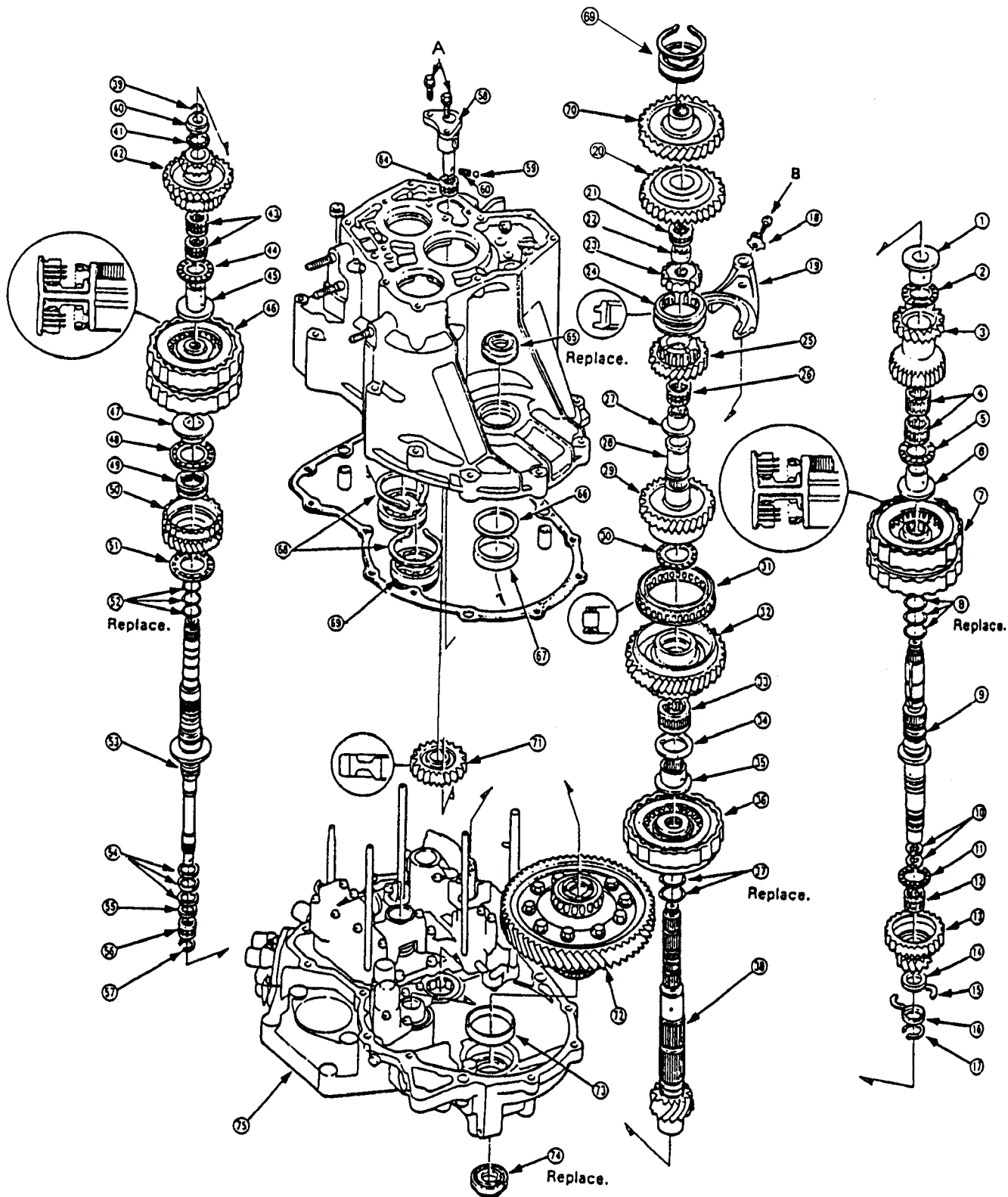

**NOTE:**

- Clean all parts thoroughly in solvent or carburetor cleaner and dry with compressed air.
- Blow out all passages.
- When removing the transmission housing, replace the following:
  - Transmission housing gasket
  - Lock washer

1. Remove the transmission housing.
2. Remove the reverse idler gear from the transmission housing.
3. Remove the countershaft 2nd gear (1990-91 use a press to remove countershaft 2nd gear from housing see figure A), reverse gear, secondary shaft 2nd gear, thrust washer, and thrust needle bearing together from the countershaft and secondary shaft.
4. Remove the lock bolt securing the shift fork, then remove the fork with the reverse selector from the countershaft.
5. Remove the needle bearings, thrust needle bearing, and splined washer from the secondary shaft.
6. Remove the secondary shaft sub-assembly.
7. Remove the mainshaft sub-assembly.
8. Remove the countershaft sub-assembly.
9. Remove the differential assembly.

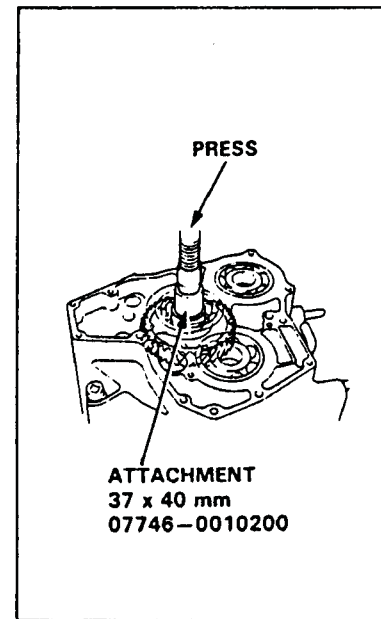
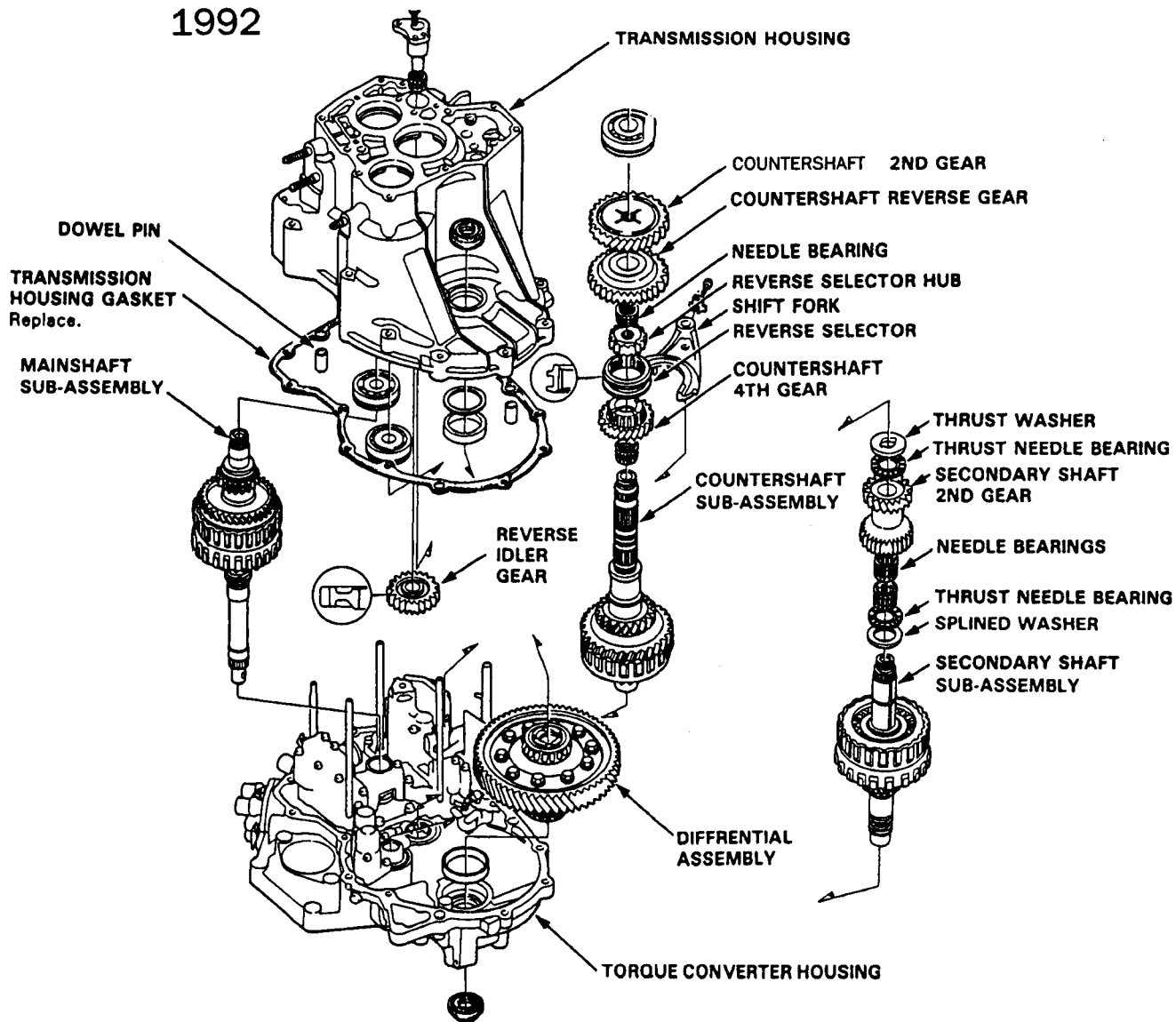
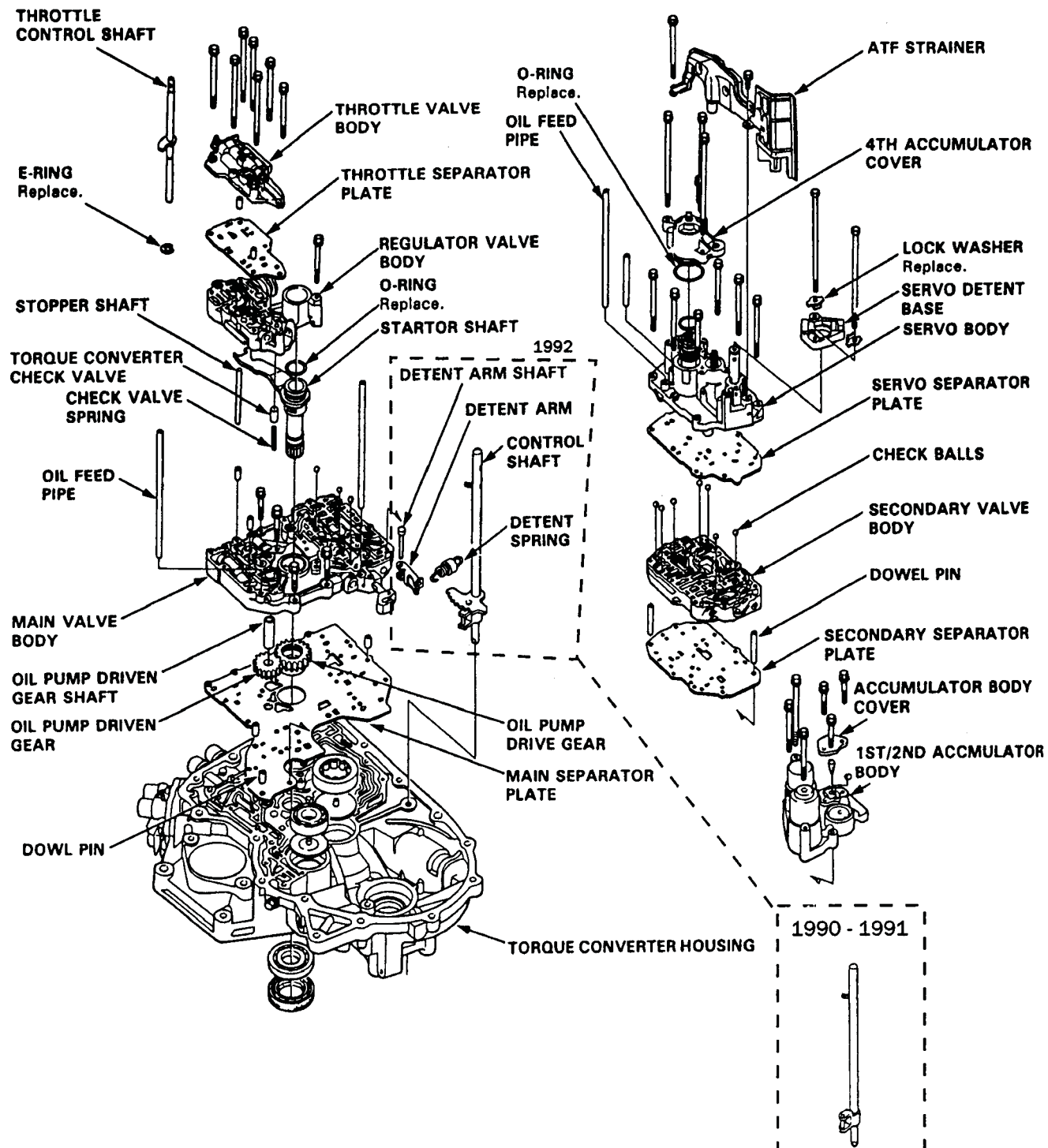

Figure A

## REMOVAL-TRANSMISSION HOUSING



## REMOVAL-TORQUE CONVERTER HOUSING / VALVE BODY





## Technical Service Information

### NOTE:

- Clean all parts thoroughly in solvent or carburetor cleaner and dry with compressed air.
- Blow out all passages.
- When removing the valve body, replace the following:
  - O-rings
  - Lock washers

1. Remove the 2 bolts securing the servo detent base, then remove the servo detent base.
2. Remove the 2 bolts securing the ATF strainer, then remove the ATF strainer.
3. Remove the oil feed pipes from the servo body and main valve body.
4. Remove the 3 bolts securing the 4th accumulator cover, then remove the 4th accumulator cover.

NOTE: The 4th accumulator cover is spring loaded, to prevent stripping the threads in the servo body, press down on the accumulator cover while unscrewing the bolts in a crisscross pattern.

5. Remove the 7 bolts securing the servo body, then remove the servo body and separator plate.
6. Remove the secondary valve body and separator plate.
7. Remove the 7 bolts securing the throttle valve body, then remove the throttle valve body and separator plate.
8. Remove the 1 bolt securing the regulator valve body, then remove the regulator valve body.

9. Remove the stator shaft and stopper shaft.
10. Remove the detent spring from the detent arm, then remove the control shaft from the torque converter housing.
11. Remove the detent arm and detent arm shaft from the main valve body.
12. Remove the 4 bolts securing the main valve body, then remove the main valve body.
13. Remove the 6 bolts securing the 1st/2nd accumulator body, then remove the 1st/2nd accumulator body.
14. Remove the oil pump driven gear shaft, then remove the oil pump gears.
15. Remove the main separator plate with 3 dowel pins.

1. Install the pump gears and shaft in the oil pump body.

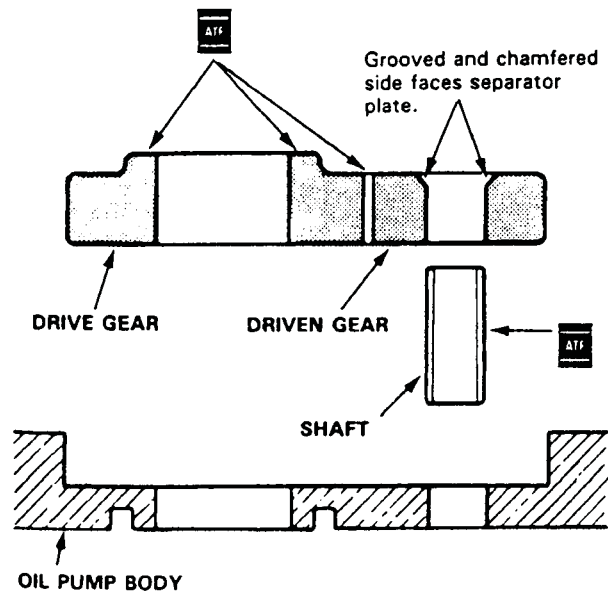
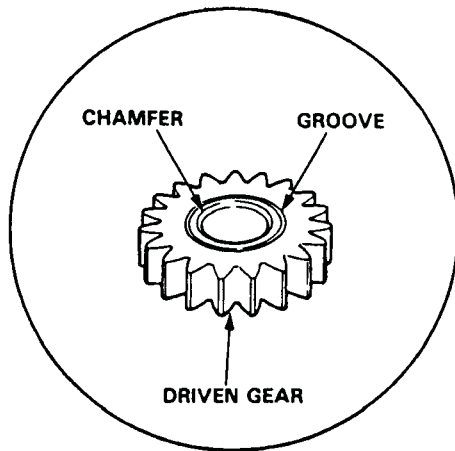

2. Measure the thrust clearance of the driven gear-to-valve body.

**Drive/Driven Gear Thrust (Axial) Clearance:**  
**Standard (New): 0.03–0.05 mm**  
**(0.001–0.002 in.)**

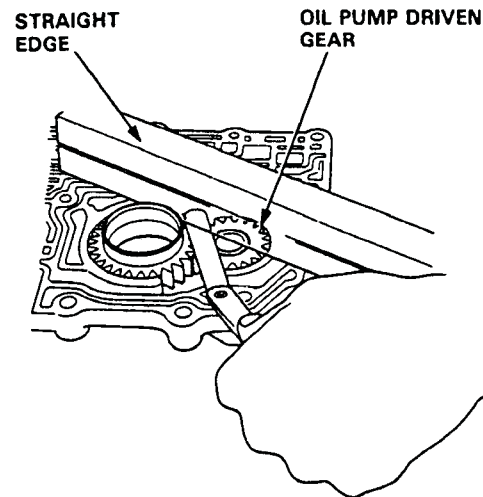

3. Install the oil pump shaft and measure the side clearance of the drive and driven gears.

**Pump Gears Side (Radial) Clearance:**  
**Standard (New): Drive gear 0.210–0.265 mm**  
**(0.0083–0.0104 in.)**  
**Driven gear 0.035–0.063 mm**  
**(0.0014–0.0025 in.)**

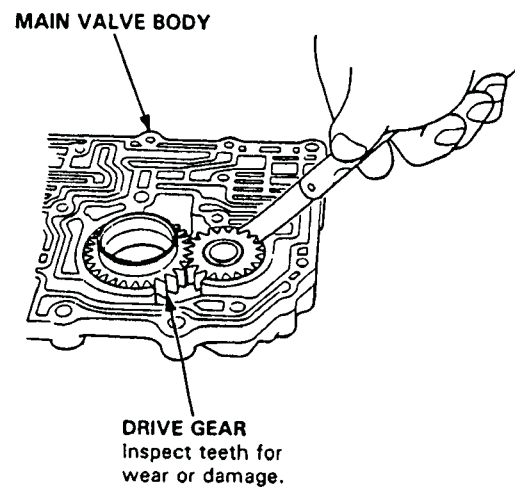

## MAIN VALVE BODY

### NOTE:

- Clean all parts thoroughly in solvent or carburetor cleaner, and dry with compressed air. Blow all passages.
- Replace valve body as an assembly if any parts are worn or damaged.
- Check all valves for free movement.

**CAUTION:** Do not use a magnet to remove the check balls; it may magnetize the balls.

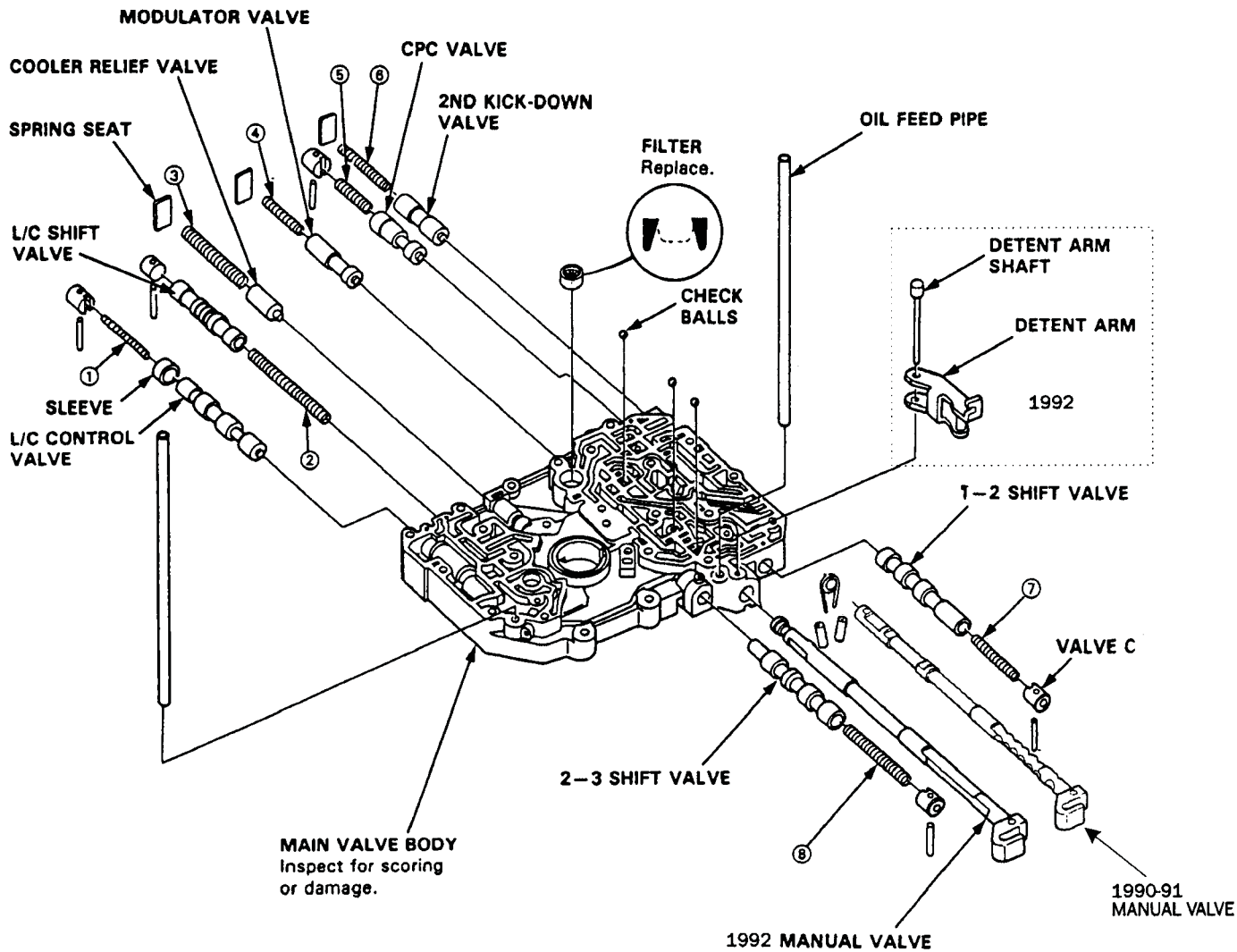

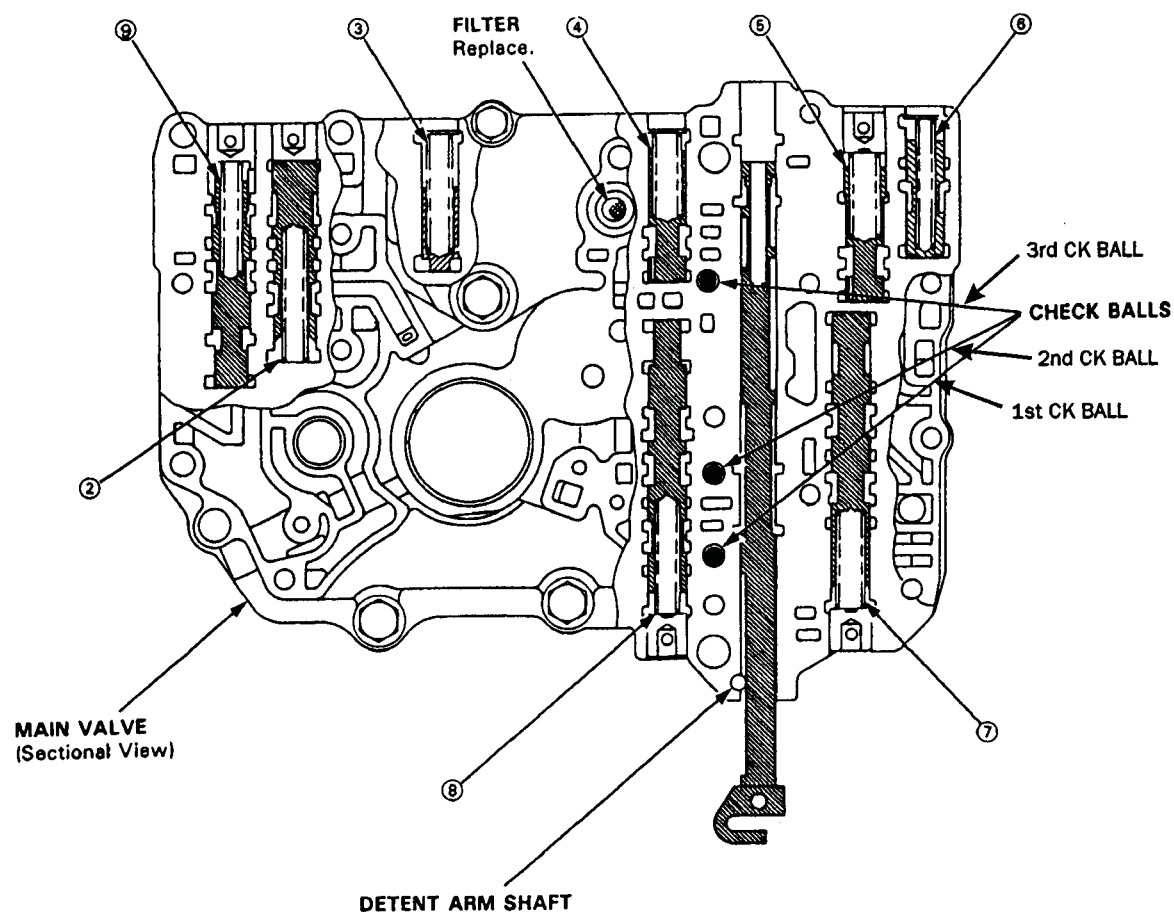

## SPRING SPECIFICATIONS

Unit of length: mm (in)

No.	SPRINGS	STANDARD (NEW)			
		WIRE DIA.	O.D.	FREE LENGTH	No. of COILS
②	Lock-up shift valve spring	0.9 (0.035)	7.6 (0.299)	73.7 (2.902)	32.0
③	Cooler relief valve spring	1.1 (0.043)	8.4 (0.331)	46.8 (1.843)	17.0
④	Modulator valve spring	1.4 (0.055)	9.4 (0.370)	33.0 (1.299)	10.5
⑤	CPC valve spring	1.4 (0.055)	9.4 (0.370)	33.0 (1.299)	10.5
⑥	2nd kick-down valve spring	1.2 (0.047)	7.1 (0.280)	46.9 (1.846)	20.6
⑦	1-2 shift valve spring	1.0 (0.039)	8.6 (0.339)	41.3 (1.626)	16.9
⑧	2-3 shift valve spring	0.9 (0.035)	7.6 (0.299)	57.0 (2.244)	26.8
⑨	Lock-up control valve spring 1990-91	0.8 (0.031)	6.6 (0.260)	41.0 (1.614)	25.0
	Lock-up control valve spring 1992	0.7 (0.028)	6.6 (0.260)	38.0 (1.496)	14.1

## SECONDARY VALVE BODY

### NOTE:

- Clean all parts thoroughly in solvent or carburetor cleaner, and dry with compressed air. Blow out all passages.
- Check all valves for free movement. If any fail to slide freely,
- Coat all parts with ATF before assembling.
- Replace the valve body as an assembly if any parts are worn or damaged.

**CAUTION:** Do not use a magnet to remove the check balls; it may magnetize the balls.

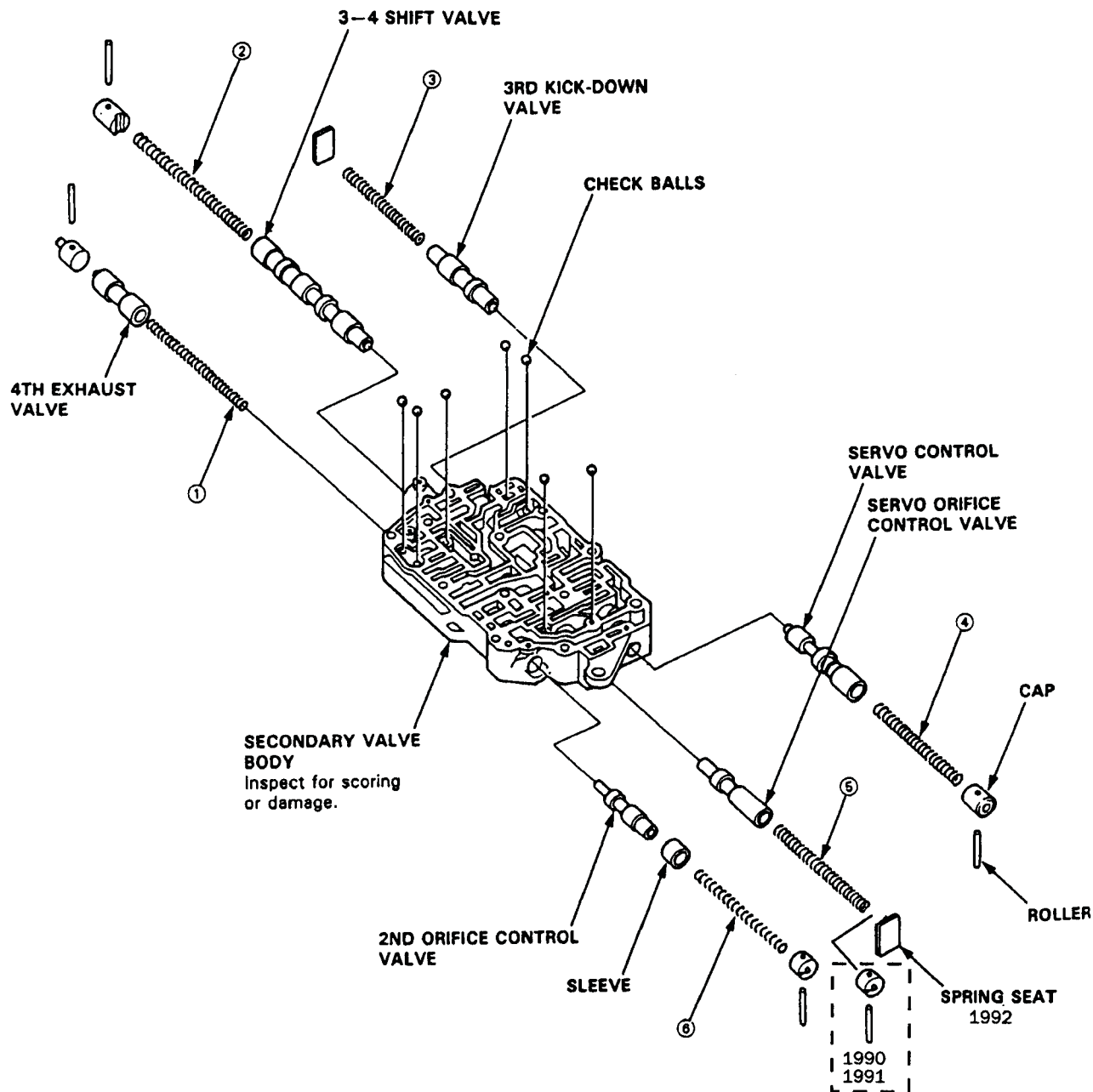

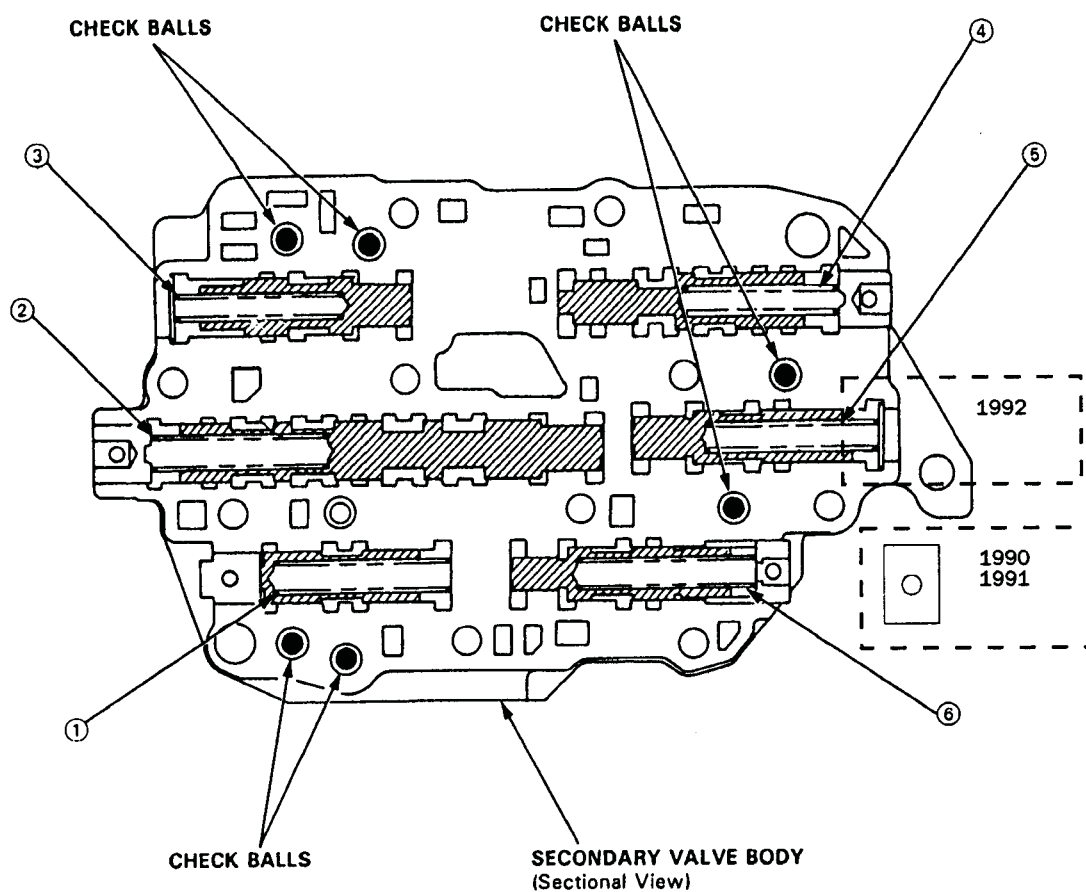

## SPRING SPECIFICATIONS

Unit of length: mm (in)

No.	SPRINGS	STANDARD (NEW)			
		WIRE DIA.	O.D.	FREE LENGTH	No. of COILS
①	4th exhaust valve spring	0.9 (0.035)	7.1 (0.280)	60.8 (2.394)	28.9
②	3-4 shift valve spring	0.9 (0.035)	7.6 (0.299)	57.0 (2.244)	26.8
③	3rd kick-down valve spring	1.1 (0.043)	7.6 (0.299)	48.3 (1.902)	23.3
④	Servo control valve spring	1.0 (0.039)	8.1 (0.319)	52.6 (2.071)	22.4
⑤	Servo orifice control valve spring	0.8 (0.031)	6.6 (0.260)	52.5 (2.067)	33.0
⑥	2nd orifice control valve spring 1992	0.6 (0.024)	6.6 (0.260)	55.8 (2.200)	15.8
	2nd orifice control valve spring 1992	0.6 (0.024)	6.6 (0.260)	52.2 (2.055)	21.0

## REGULATOR VALVE BODY

### NOTE:

- Clean all parts thoroughly in solvent or carburetor cleaner, and dry with compressed air. Blow out all passages.
- Check all valves for free movement
- Replace the valve body as an assembly if any parts are worn or damaged.

1. Hold the regulator spring cap in place while removing the stopper bolt. Once the bolt is removed, release the spring cap slowly.

**CAUTION:** The regulator spring cap can pop out when the stopper bolt is removed.

2. Reassembly is in the reverse order of disassembly.

### NOTE:

- Coat all parts with ATF.
- Align the hole in the regulator spring cap with the hole in the valve body, then press the spring cap into the valve body and tighten the stopper bolt.

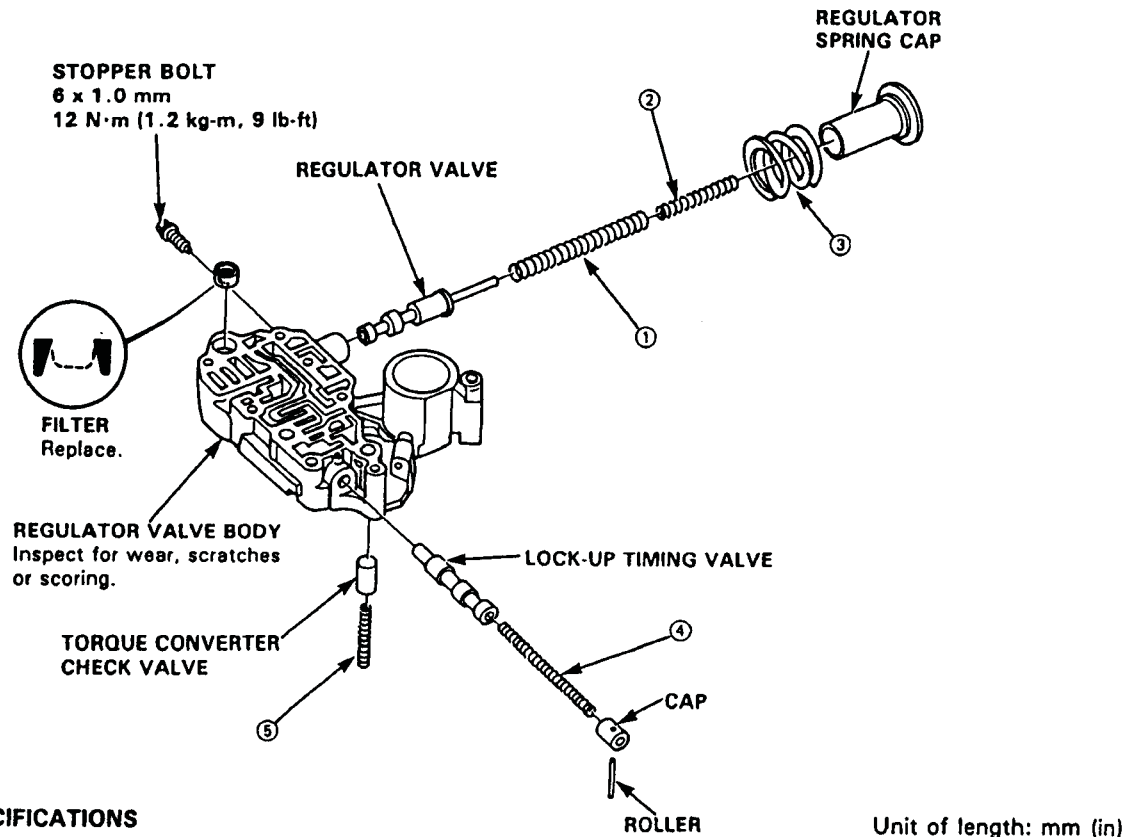

### SPRING SPECIFICATIONS

Unit of length: mm (in)

No.	SPRINGS	STANDARD (NEW)			
		WIRE DIA.	O.D.	FREE LENGTH	No. of COILS
1992	① Regulator valve spring A	1.8 (0.071)	14.7 (0.579)	86.5 (3.406)	16.5
	② Regulator valve spring B	1.8 (0.071)	9.6 (0.378)	44.0 (1.732)	12.7
	③ Stator reaction spring	4.5 (0.177)	35.4 (1.394)	30.3 (1.193)	1.92
	④ Lock-up timing valve spring	0.8 (0.031)	6.6 (0.260)	51.1 (2.012)	14.7
	⑤ Torque converter check valve spring	1.1 (0.043)	8.4 (0.331)	36.4 (1.433)	12.0
1990 1991	② Regulator valve spring B	1.8 (0.071)	6.0 (0.236)	44.0 (1.732)	12.7
	③ Stator reaction spring	5.5 (0.216)	37.4(1.472)	30.3 (1.193)	2.1
	④ Lock-up timing valve spring	0.8 (0.031)	6.6 (0.260)	64.0 (2.520)	40.1
	⑤ Torque converter check valve spring	1.1 (0.043)	8.4 (0.331)	33.8 (1.331)	12.5

## THROTTLE VALVE BODY

### NOTE:

- Clean all parts thoroughly in solvent or carburetor cleaner, and dry with compressed air. Blow out all passages.
- Check all valves for free movement
- Coat all parts with ATF before assembly.
- Replace the valve body as an assembly if any parts are worn or damaged.

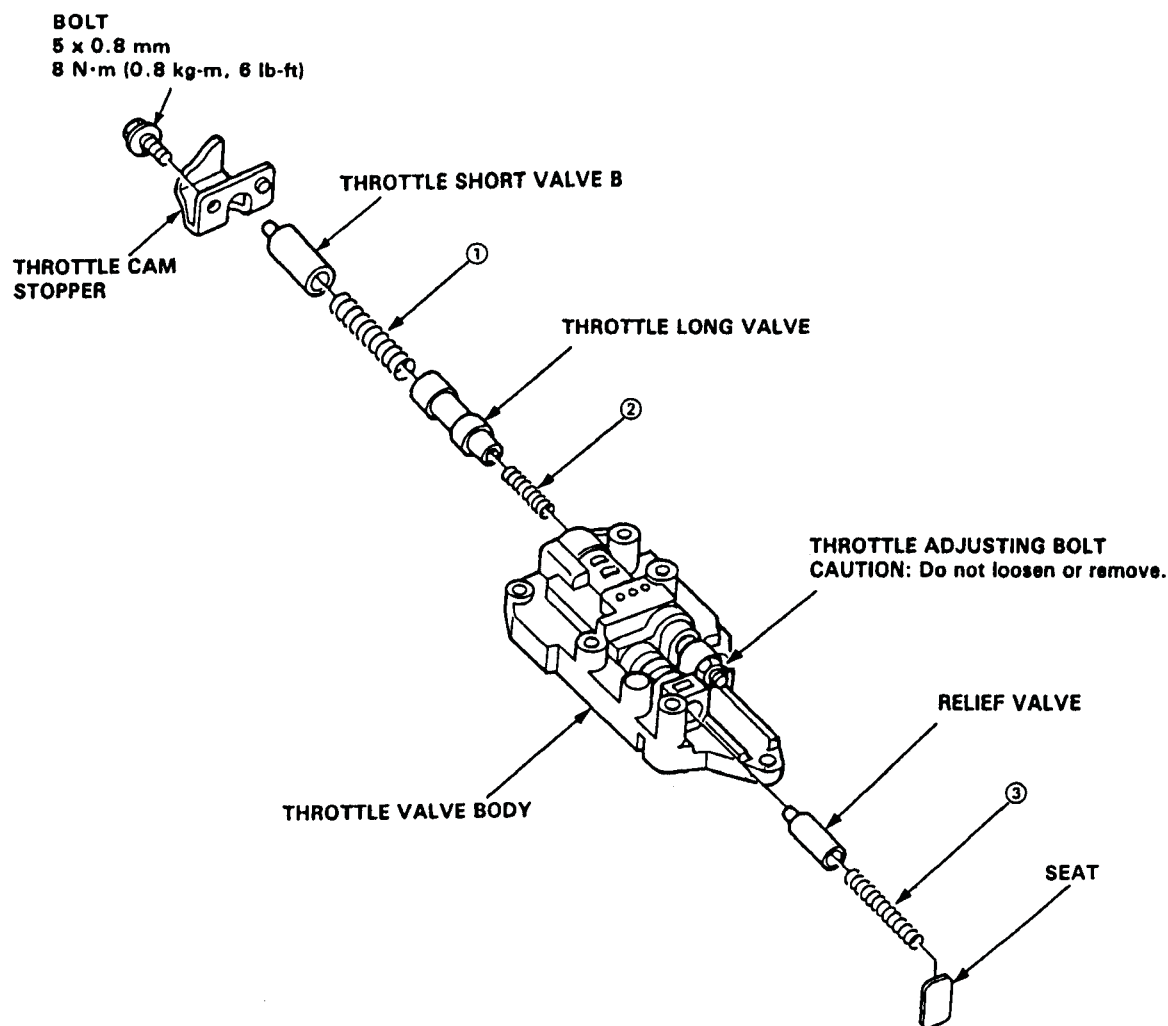

### SPRING SPECIFICATIONS

Unit of length: mm (in)

No.	SPRINGS	STANDARD (NEW)			
		WIRE DIA.	O.D.	FREE LENGTH	No. of COILS
①	Throttle valve B spring	1.4 (0.055)	8.5 (0.335)	41.5 (1.634)	10.5
		1.4 (0.055)	8.5 (0.335)	41.5 (1.634)	11.2
		1.4 (0.055)	8.5 (0.335)	41.6 (1.638)	12.4
②	Throttle valve B adjusting spring	0.8 (0.031)	6.2 (0.244)	30.0 (1.181)	8.0
③	Relief valve spring	1.0 (0.039)	8.4 (0.331)	39.1 (1.539)	15.1

## SERVO BODY

### NOTE:

- Clean all parts thoroughly in solvent or carburetor cleaner, and dry with compressed air. Blow out all passages.
- Replace the servo body as an assembly if any parts are worn or damaged.
- Replace ATF strainer if its inlet opening is clogged.
- Coat all parts with ATF before assembly.

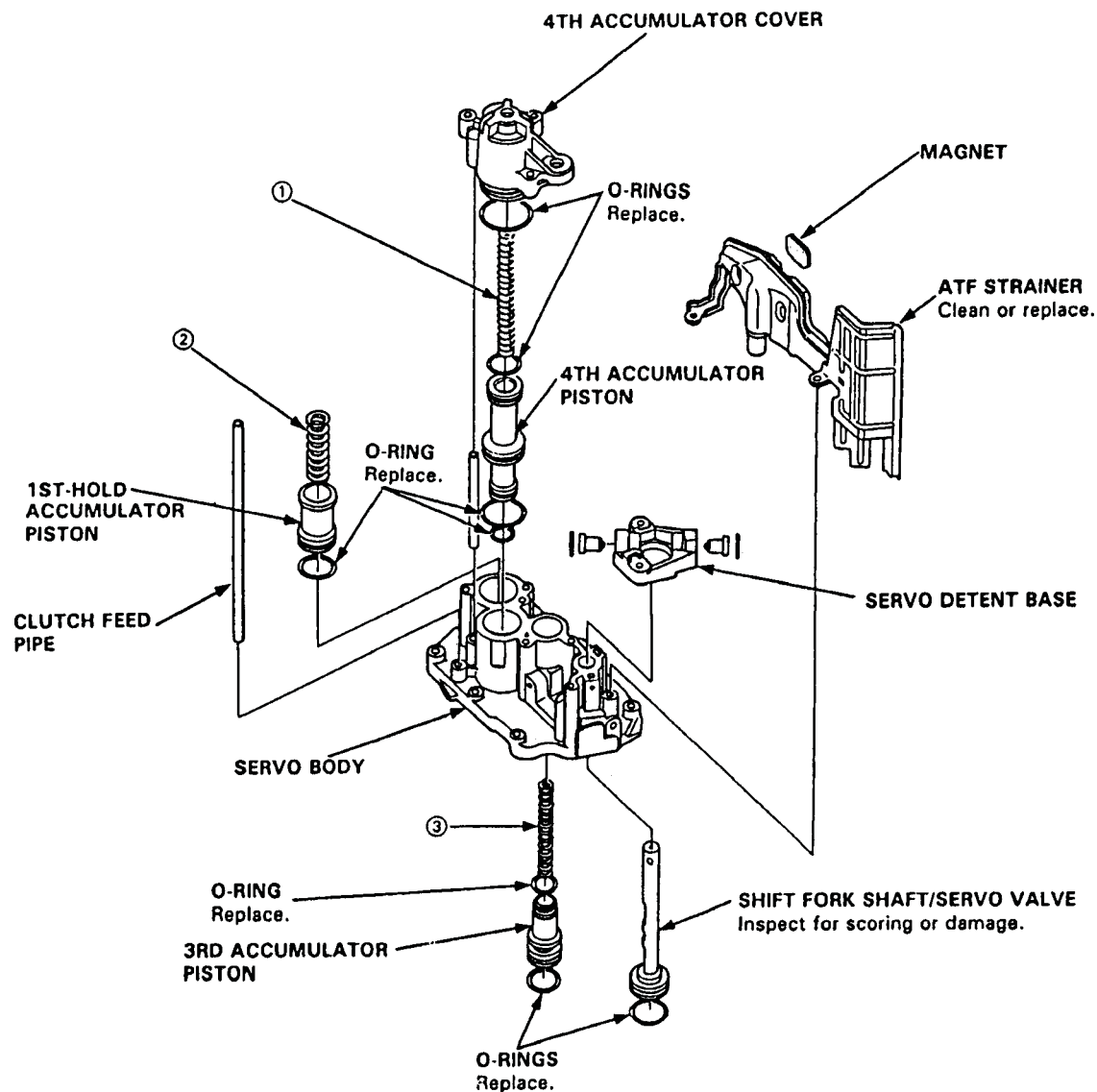

### SPRING SPECIFICATIONS

Unit of length: mm (in)

No.	SPRINGS	STANDARD (NEW)			
		WIRE DIA.	O.D.	FREE LENGTH	No. of COILS
①	4th accumulator spring	2.9 (0.114)	22.0 (0.866)	90.1 (3.547)	10.9
②	1st-hold accumulator spring	4.0 (0.157)	25.0 (0.984)	64.7 (2.547)	7.3
③	3rd accumulator spring	2.8 (0.110)	17.5 (0.689)	94.2 (3.709)	16.1



# Technical Service Information

## 1st/2nd ACCUMULATOR BODY

### NOTE:

- Clean all parts thoroughly in solvent or carburetor cleaner, and dry with compressed air. Blow out all passages.
- Coat all parts with ATF before assembly.

**CAUTION:** Do not use a magnet to remove the steel ball; it may magnetize the ball.

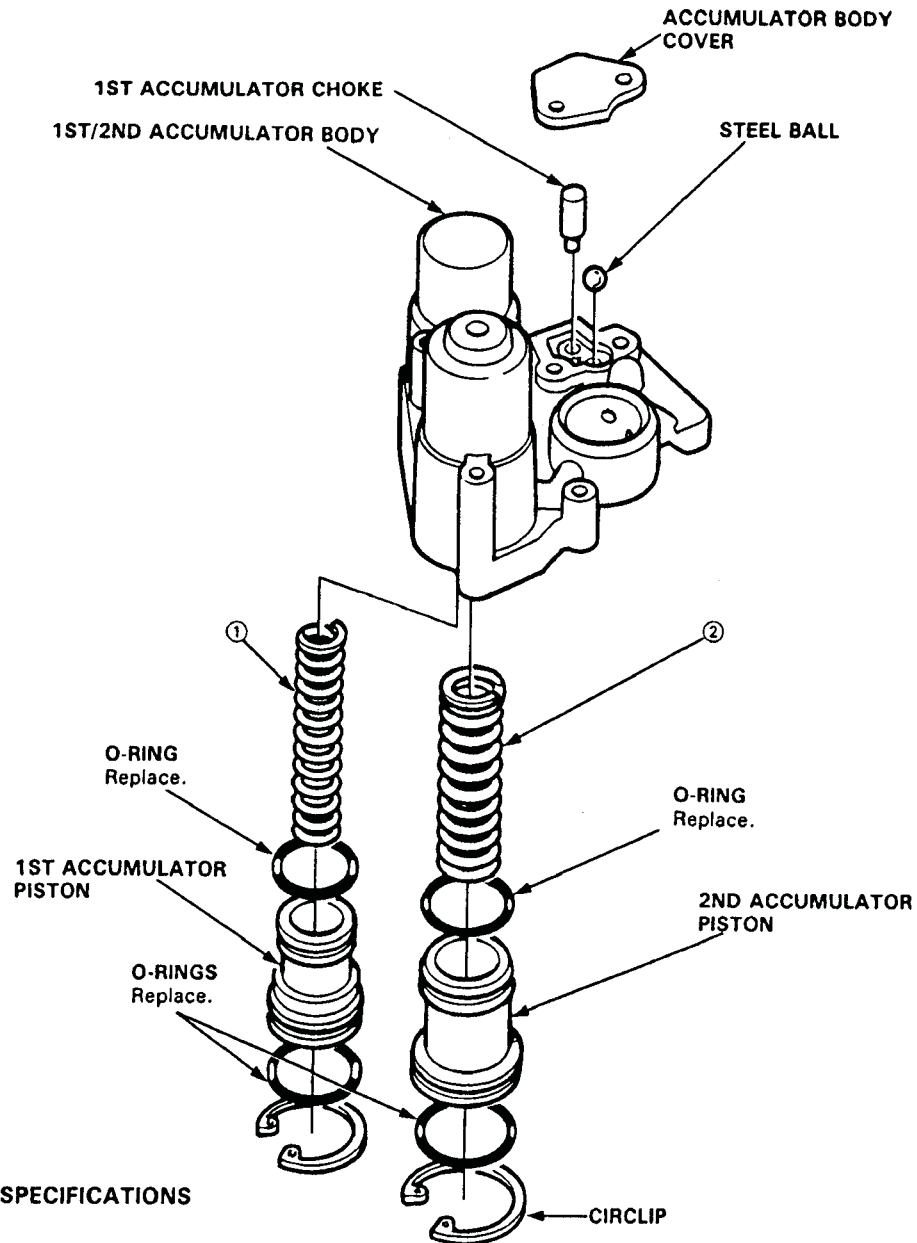

### SPRING SPECIFICATIONS

Unit of length: mm (in)

No.	SPRINGS	STANDARD (NEW)			
		WIRE DIA.	O.D.	FREE LENGTH	No. of COILS
1992	① 1st accumulator spring	1.8 (0.071)	16.3 (0.642)	115.4 (4.543)	18.6
	② 2nd accumulator spring	3.5 (0.138)	22.0 (0.866)	77.1 (3.035)	10.0
1990 1991	① 1st accumulator spring	2.1 (0.083)	16.3 (0.642)	96.0 (3.780)	17.1
	② 2nd accumulator spring	3.2 (0.126)	20.7 (0.815)	80.7 (3.177)	10.8



# Technical Service Information

## MAIN SHAFT

### NOTE:

- Lubricate all parts with ATF during reassembly.
- Install thrust needle bearings with unrolled edge of bearing retainer facing washer.
- Inspect thrust needle bearings for galling and rough movement.
- Before installing the O-rings, wrap the shaft splines with tape to prevent damage to the O-rings.

**CAUTION: LOCKNUT AND WASHER  
MUST BE REPLACED**

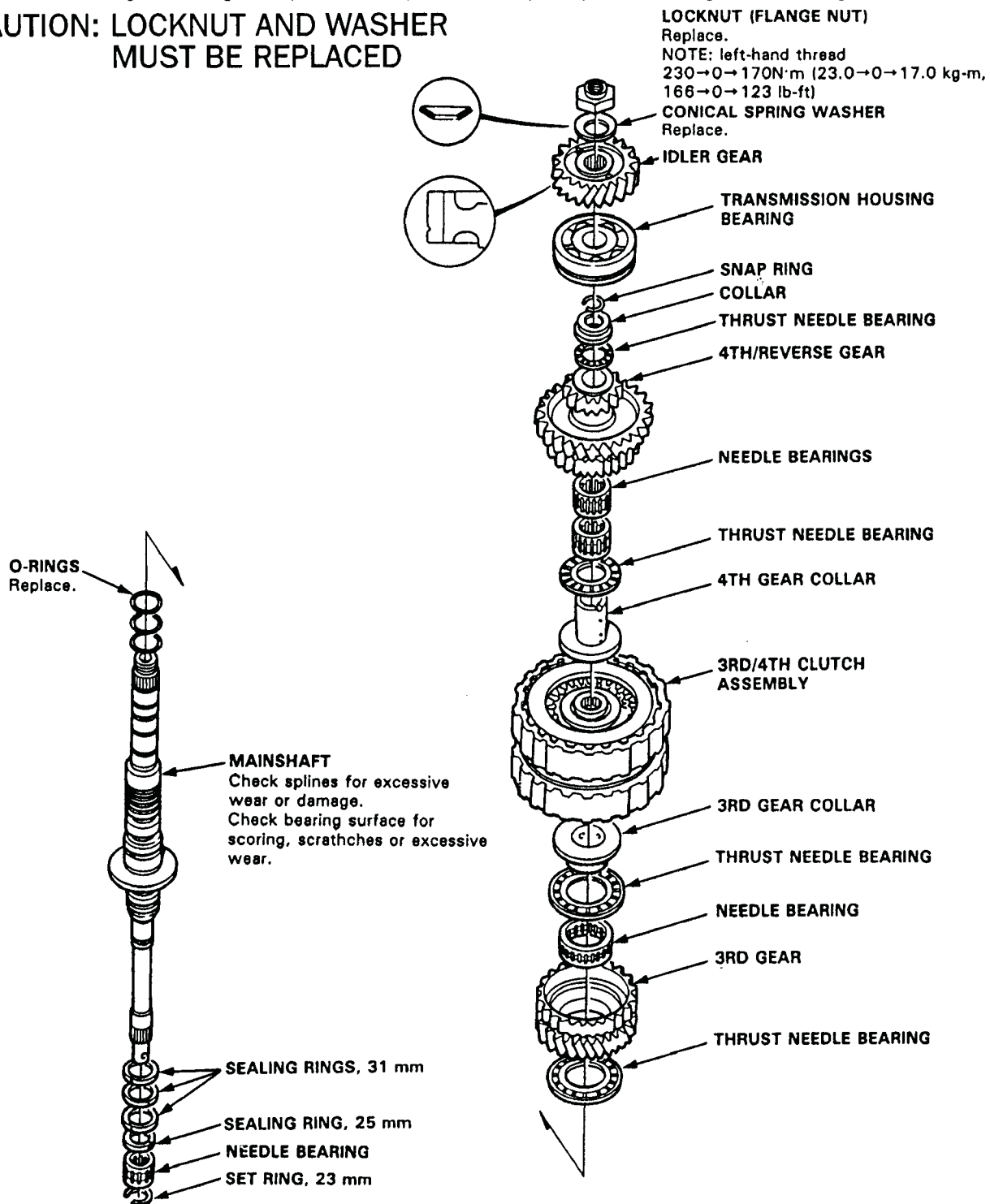

## COUNTERSHAFT

### 1990-91

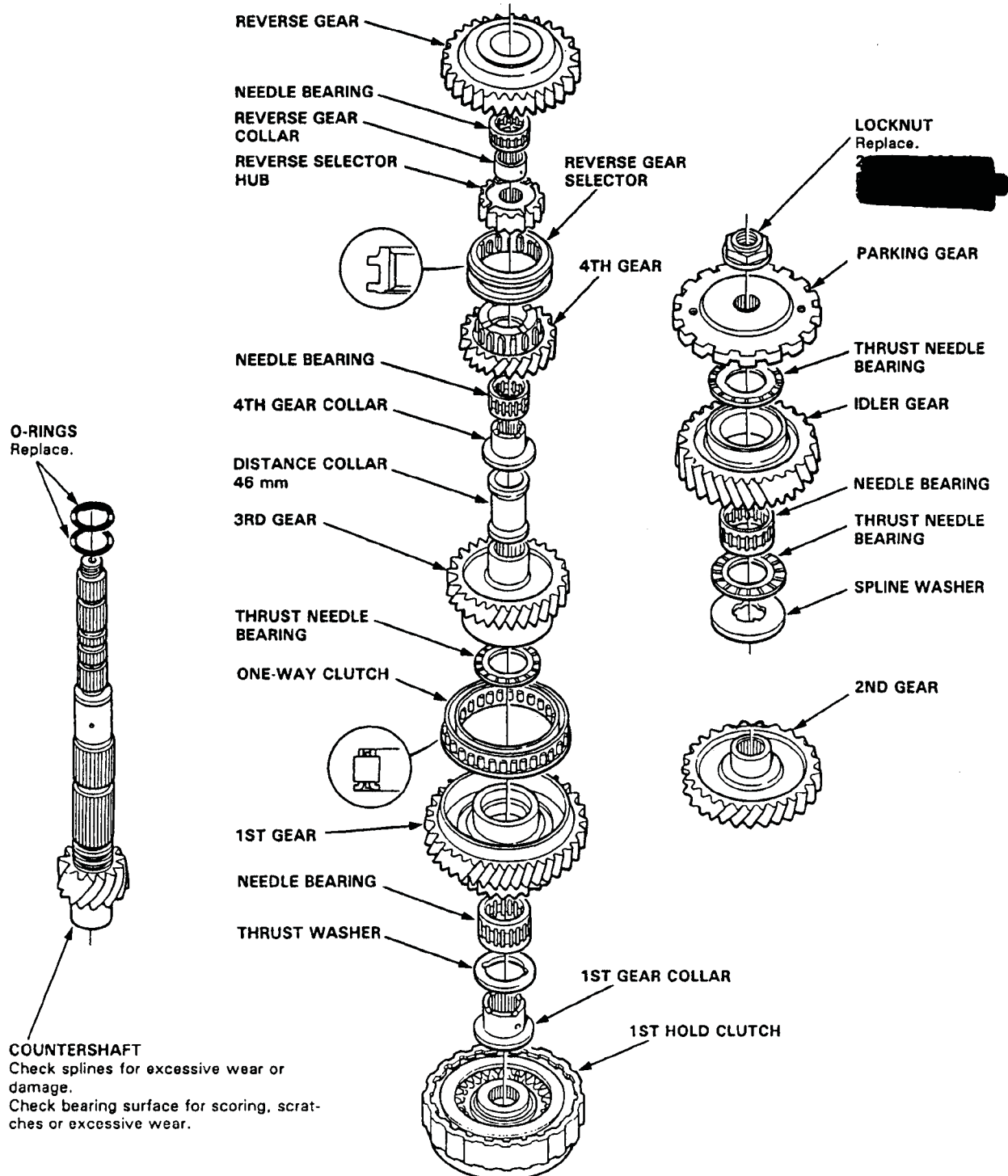

## COUNTERSHAFT - 1992

### NOTE:

- Lubricate all parts with ATF during reassembly.
- Install thrust needle bearings with unrolled edge of bearing retainer facing washer.
- Inspect thrust needle bearings for galling and rough movement.
- Before installing the O-rings, wrap the shaft splines with tape to prevent damage to the O-rings.

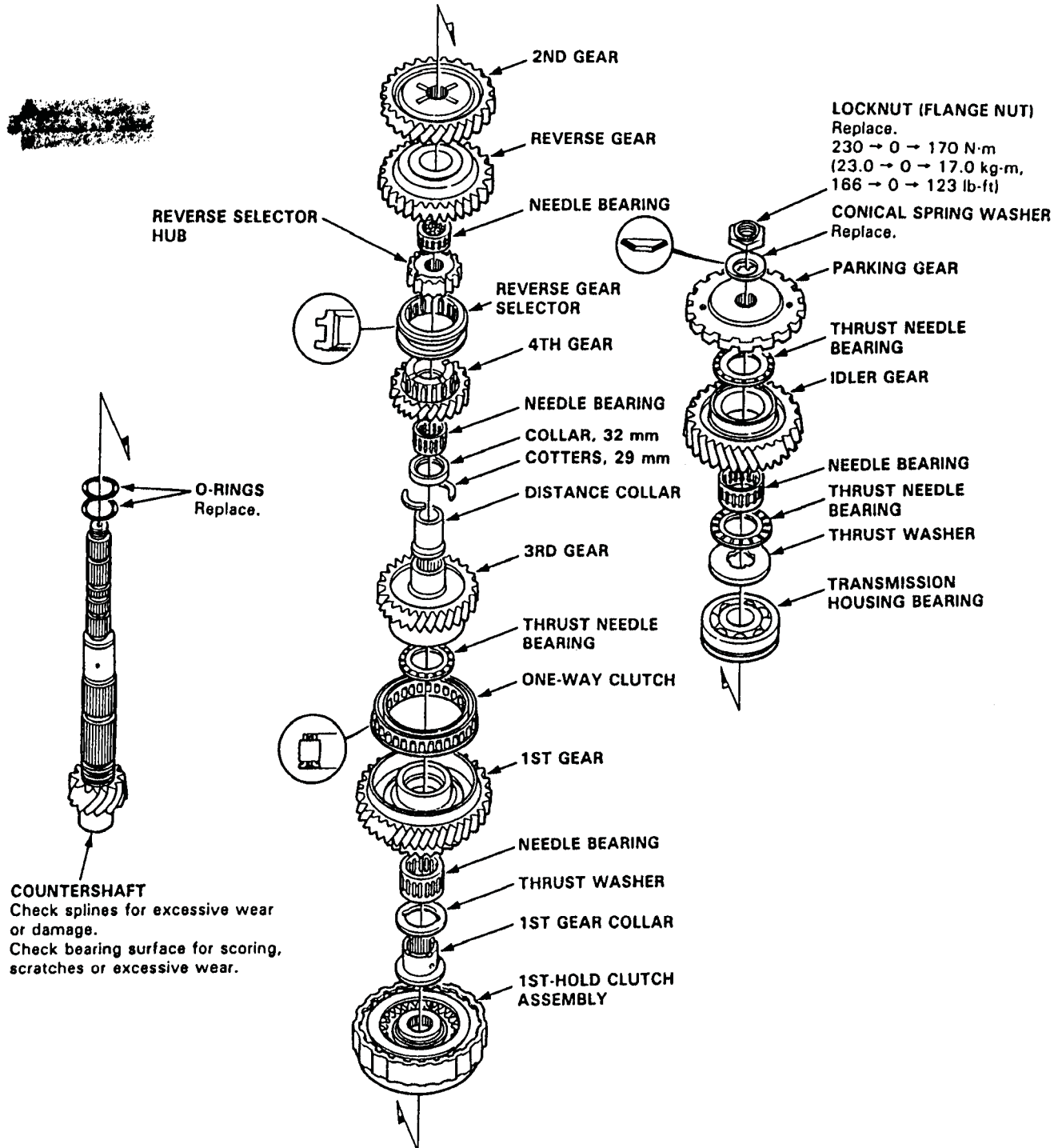

## COUNTERSHAFT

### REMOVAL

- Using a hydraulic press, press out the countershaft while supporting the 1st-hold clutch drum.

**NOTE:** Place an attachment between the hydraulic press and countershaft to prevent damage to the shaft.

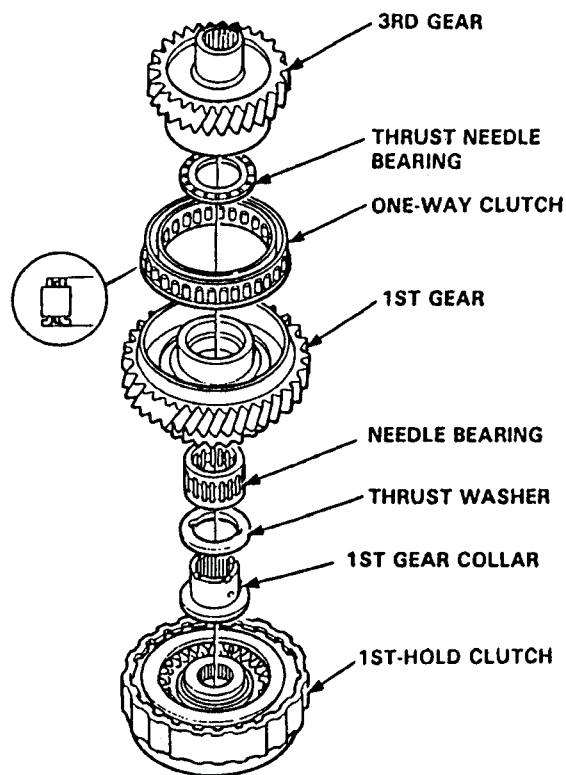
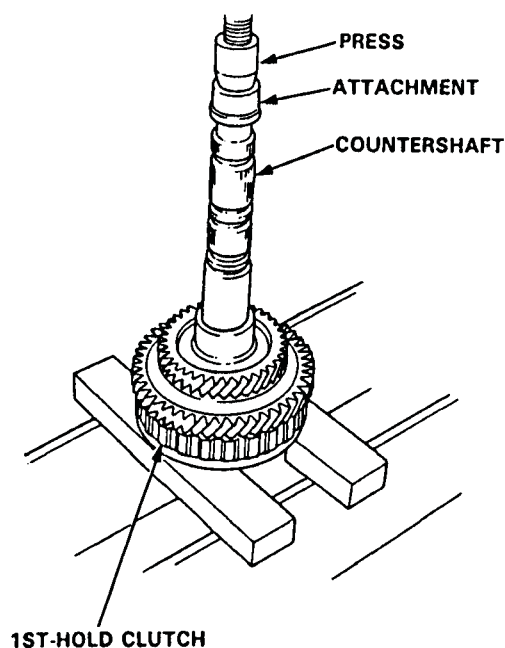

- Align the shaft splines with those of 3rd gear, then press the countershaft into 3rd gear with the hydraulic press.

### NOTE:

- Also align the shaft splines with those of the 1st-hold clutch when pressing the countershaft into the 3rd gear.
- Use an attachment between the shaft and hydraulic press to prevent damage to the countershaft.
- Stop pressing the countershaft when the 1st-hold clutch contacts the final drive gear.

### ASSEMBLY

**NOTE:** Lubricate all parts with ATF during assembly.

Install two new O-rings on the countershaft.

**NOTE:** Before installing the O-rings, wrap the shaft splines with tape to prevent damage to the O-rings.

- Assemble the 1st-hold clutch, 1st gear collar, thrust washer, needle bearing, 1st gear, one-way clutch, thrust needle bearing and 3rd gear.

Install the above assembly on the countershaft.

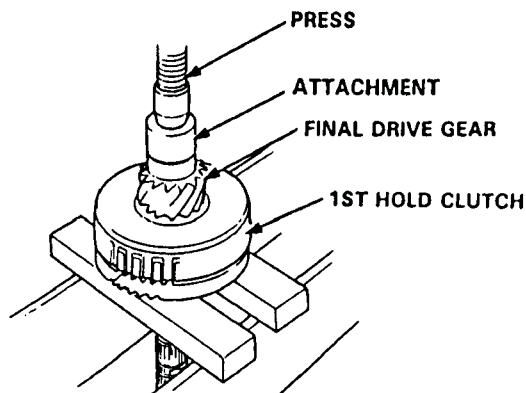

## ONE-WAY CLUTCH

1. Separate the countershaft 3rd gear from the 1st gear by turning the 3rd gear in the direction shown.

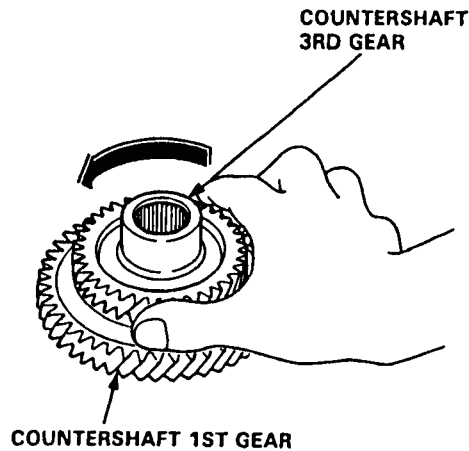

2. Remove the one-way clutch by prying it up with the end of a screwdriver.

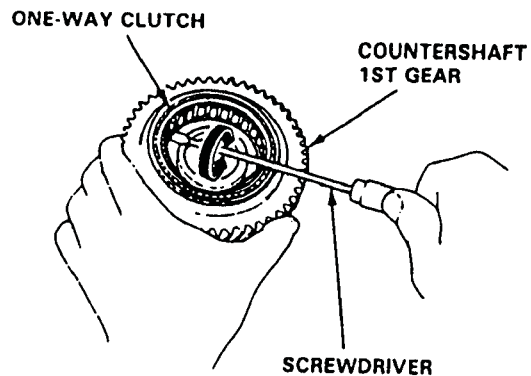

3. Inspect the parts as follows:

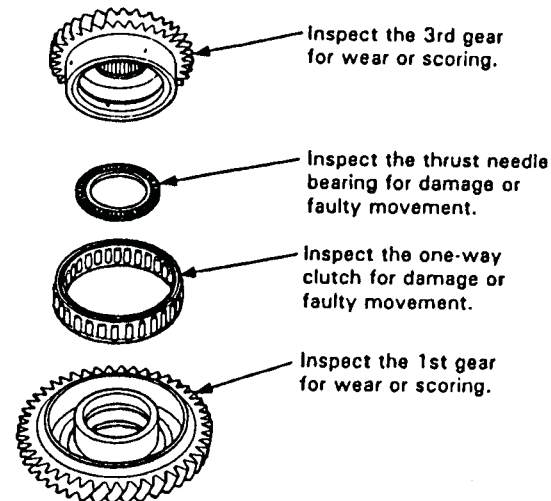

4. After the parts are assembled, hold the countershaft 1st gear and turn the 3rd gear in direction shown to be sure it turns freely.

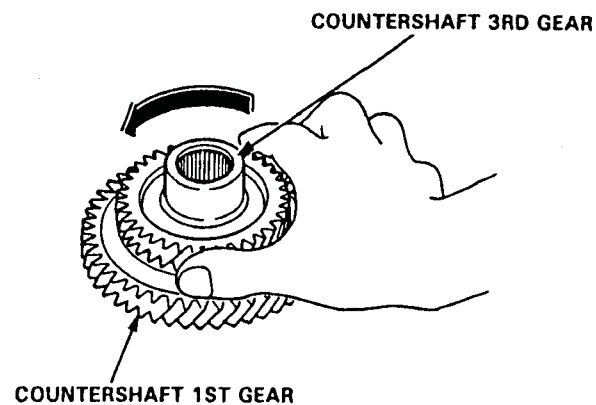

## SECONDARY SHAFT

### NOTE:

- Lubricate all parts with ATF during reassembly.
- Install thrust needle bearings with unrolled edge of bearing retainer facing washer.
- Inspect thrust needle and needle bearings for galling and rough movement.
- Before installing the O-ring, wrap the shaft splines with tape to prevent damage to the O-rings.

**CAUTION: NUT AND WASHER  
MUST BE REPLACED**

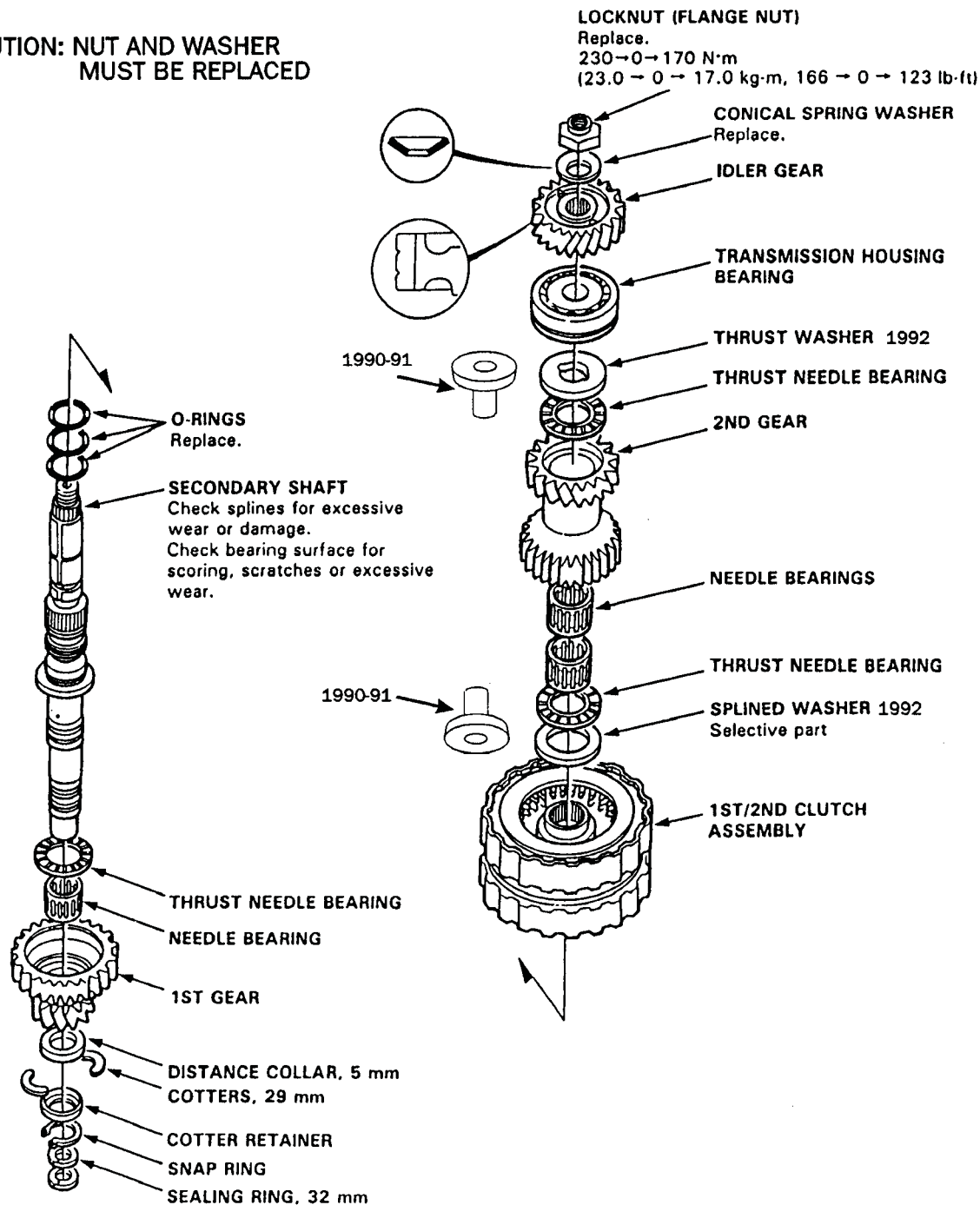

1992 ONLY

● Clearance Measurement

NOTE: Lubricate all parts with ATF during assembly.

1. Remove the secondary shaft bearing from the transmission housing
2. Assemble the secondary shaft assembly without O-rings, then torque the secondary shaft locknut to 30 N·m (3.0 kg·m, 22 lb-ft).

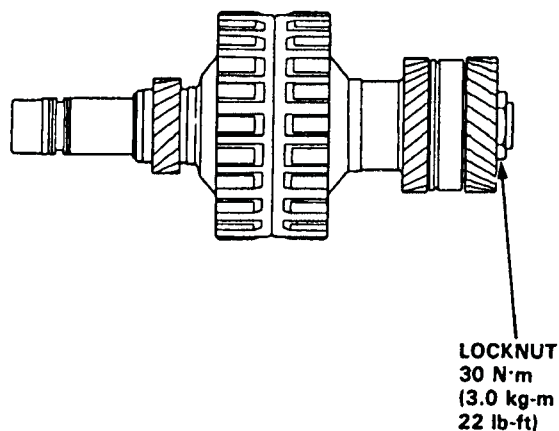

3. Attach the dial indicator to the secondary shaft 2nd gear as shown.

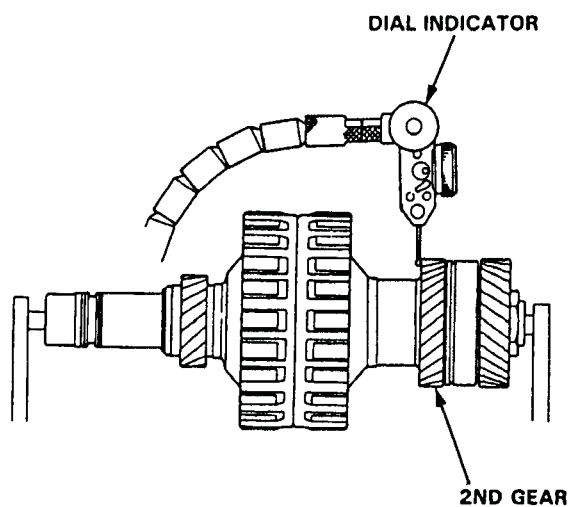

4. Measure the 2nd gear axial clearance moving the 2nd gear.

**STANDARD: 0.07–0.15 mm (0.003–0.006 in)**

NOTE: Take measurement in at least three places and take average as the actual clearance.

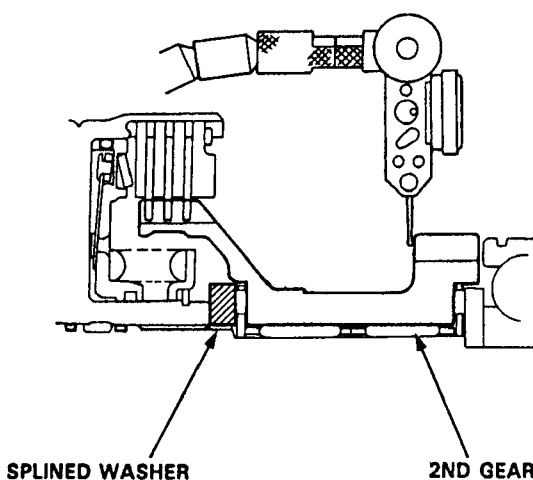

5. If the clearance is out of tolerance, remove the splined washer and measure the thickness.

**SPLINED WASHER**

No	Part Number	Thickness
1	90406-PX4-700	4.05 mm (0.159 in)
2	90407-PX4-700	4.10 mm (0.161 in)
3	90408-PX4-700	4.15 mm (0.163 in)
4	90409-PX4-700	4.20 mm (0.165 in)
5	90410-PX4-700	4.25 mm (0.167 in)
6	90411-PX4-700	4.30 mm (0.169 in)
7	90412-PX4-700	4.35 mm (0.171 in)
8	90413-PX4-700	4.40 mm (0.173 in)
9	90414-PX4-700	4.45 mm (0.175 in)

6. After replacing the splined washer, make sure that the clearance is within tolerance.

## 3rd/4th CLUTCH

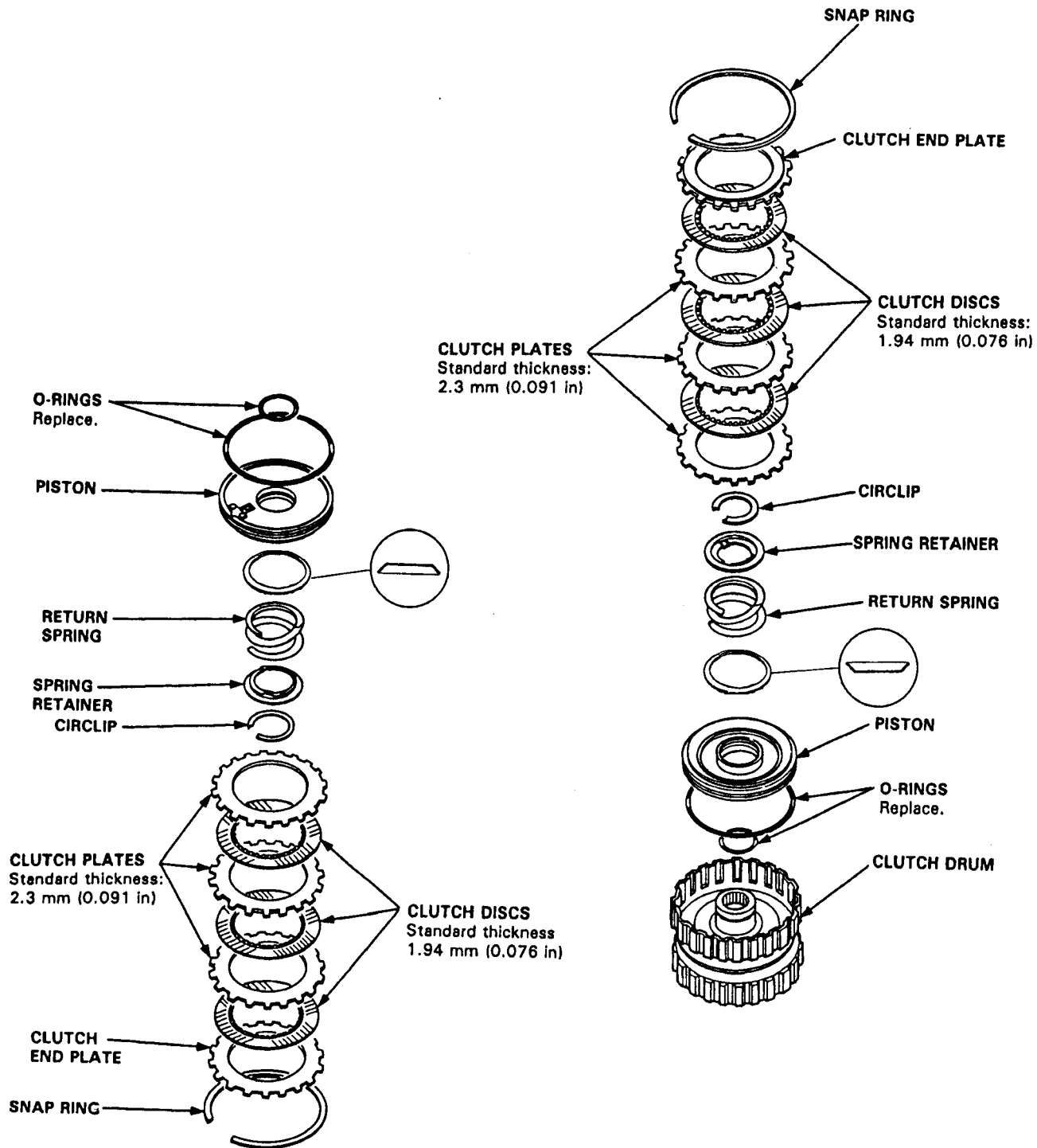

## 1st/2nd CLUTCH

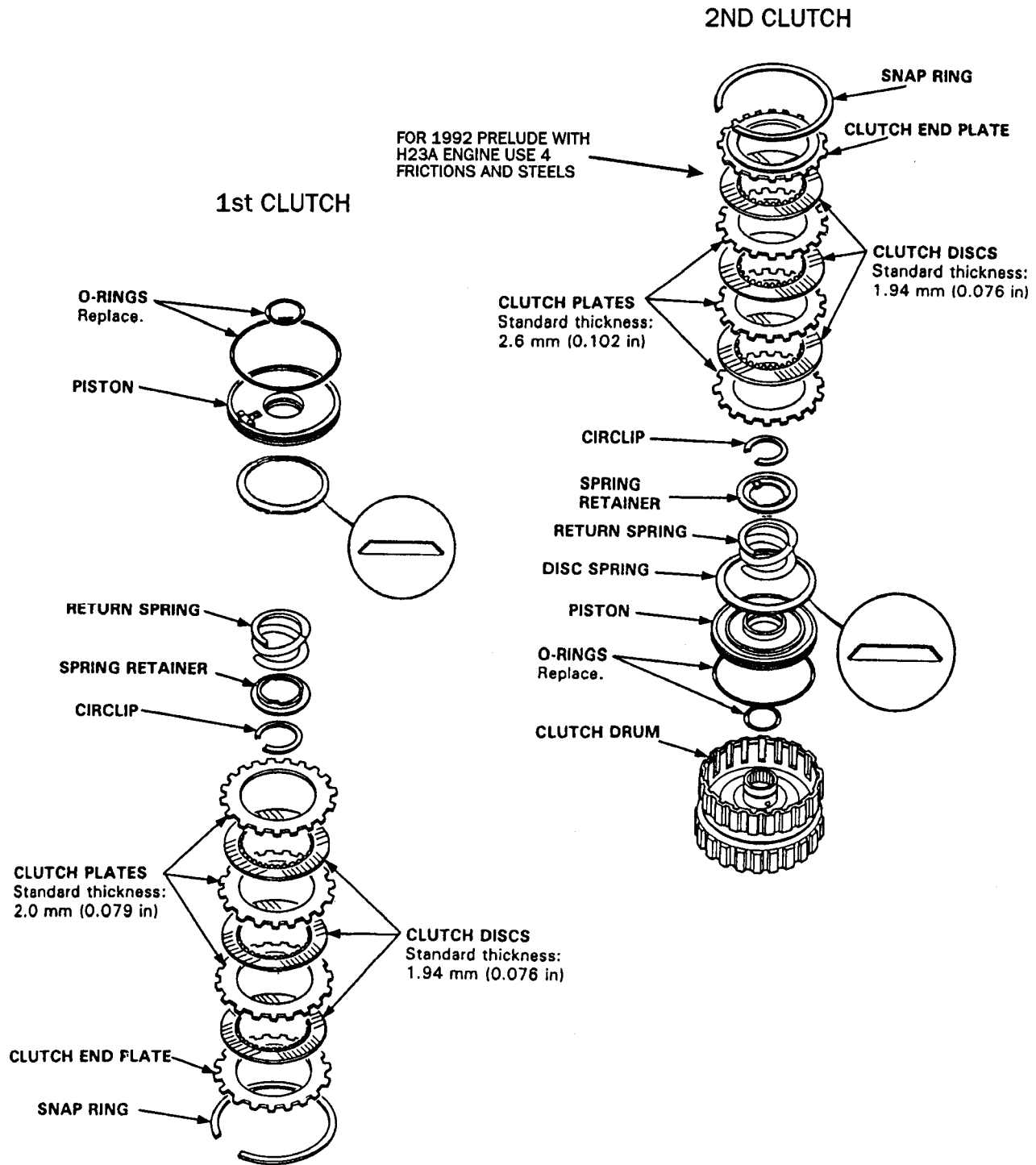



# Technical Service Information

1st HOLD CLUTCH

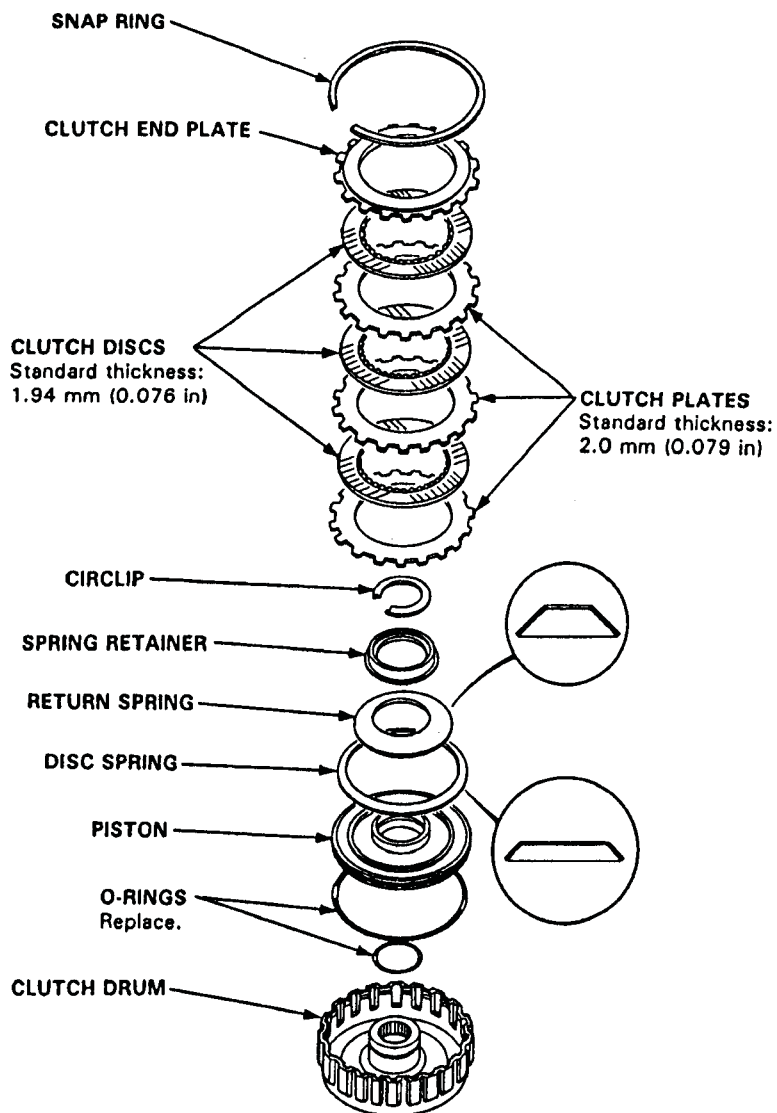



## Technical Service Information

Measure the clearance between the clutch end plate and top disc with a dial indicator. Zero the dial indicator with the clutch end plate lowered, and lift it up to the snap ring. The distance that the clutch end plate moves is the clearance between the clutch end plate and top disc.

NOTE: Measure at three locations.

### End Plate-to-Top Disc Clearance:

	Service Limit	
1st	0.65–0.85 mm	(0.026–0.033 in)
2nd	0.65–0.85 mm	(0.026–0.033 in)
3rd	0.40–0.60 mm	(0.016–0.024 in)
4th	0.40–0.60 mm	(0.016–0.024 in)
1st-Hold	0.80–1.00 mm	(0.031–0.039 in)

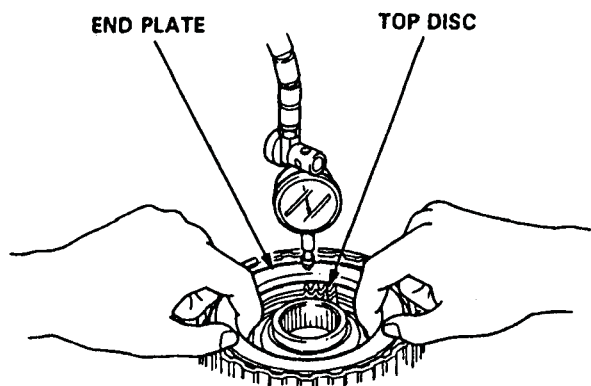

If the clearance is not within the service limits, select a new clutch end plate from the following table.

NOTE: If the thickest clutch end plate is installed but the clearance is still over the standard, replace the clutch discs and clutch plates.

### CLUTCH END PLATE

PLATE No.	P/N	THICKNESS mm (in)
1	22551-PX4-003	2.1 (0.082)
2	22552-PX4-003	2.2 (0.086)
3	22553-PX4-003	2.3 (0.090)
4	22554-PX4-003	2.4 (0.094)
5	22555-PX4-003	2.5 (0.098)
6	22556-PX4-003	2.6 (0.102)
7	22557-PX4-003	2.7 (0.106)
8	22558-PX4-003	2.8 (0.110)
9	22559-PX4-003	2.9 (0.114)

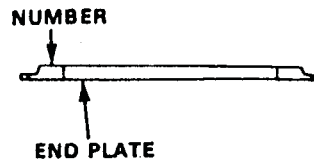

## MAINSHAFT BEARING / OIL SEAL REPLACEMENT

1. Drive out the mainshaft bearing and oil seal, using the special tools.

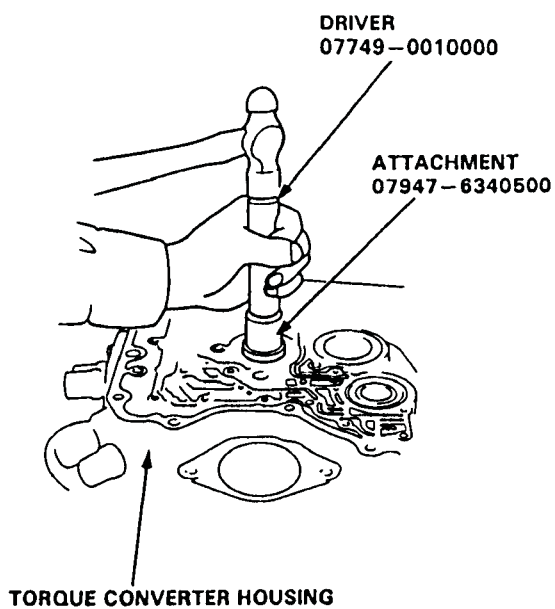

3. Install the new oil seal flush with the housing, using the special tools.

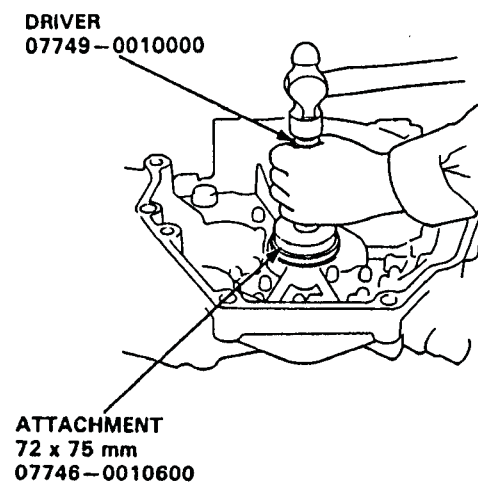

2. Drive in the new mainshaft bearing until it bottoms in the housing, using the special tools.

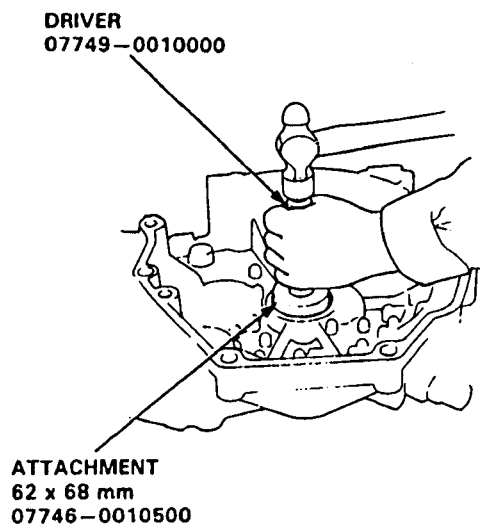

## Countershaft Bearing Replacement

1. Remove the countershaft bearing using the special tool.

Commercially Available  
3/8 in. x 16 threads/in.  
slide hammer.

ADJUSTABLE  
BEARING  
PULLER,  
25-40 mm  
07736-A01000A

COUNTERSHAFT  
NEEDLE BEARING  
Replace.

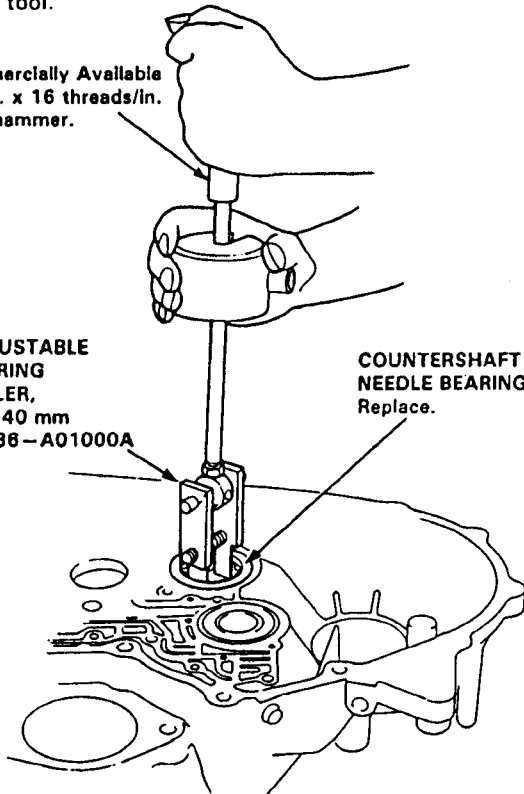

2. Replace the oil guide plate.
3. Drive the new bearing into the housing, using the special tools.

DRIVER  
07749-0010000

ATTACHMENT  
62 x 68 mm  
07746-0010500

BEARING  
0-0.03 mm  
(0-0.001 in)

HOUSING

OIL GUIDE PLATE  
Replace.

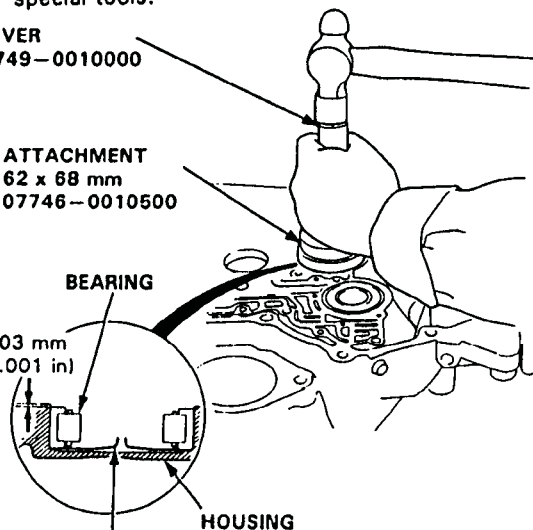

## Secondary Shaft Bearing Replacement

1. Remove the secondary shaft bearing by heating the torque converter housing to 100°C (212°F) with a heat gun, then tap the housing until the bearing falls out.  
**CAUTION:** Do not heat the housing in excess of 212°F (100°C).

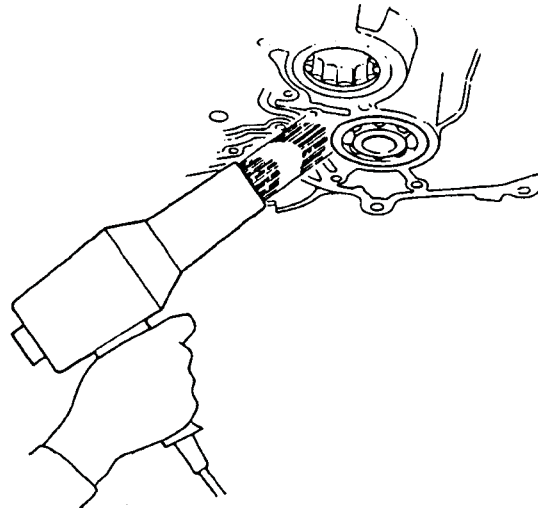

2. Replace the oil guide plate.
3. Drive the new bearing into the housing, using the special tools.

DRIVER  
07749-0010000

ATTACHMENT  
52 x 55 mm  
07746-0010400

BEARING  
0-0.03 mm  
(0-0.001 in)

HOUSING

OIL GUIDE PLATE  
Replace.

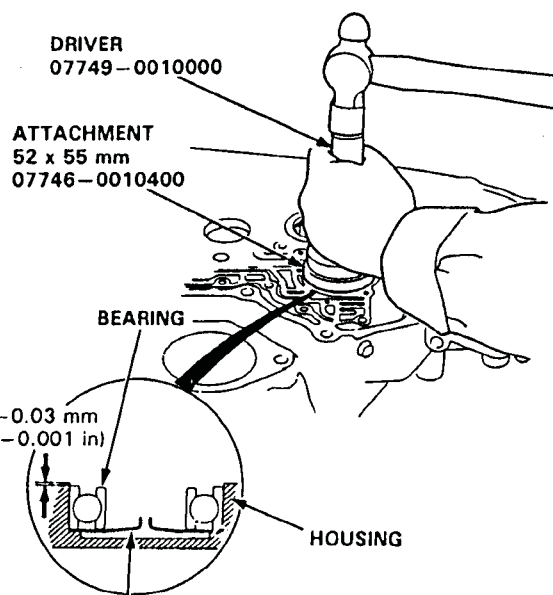

1. To remove the mainshaft, countershaft and secondary shaft bearings from the transmission housing, expand each snap ring with snap ring pliers, then push the bearing out.

**NOTE:** Do not remove the snap rings unless it's necessary to clean the grooves in the housing.

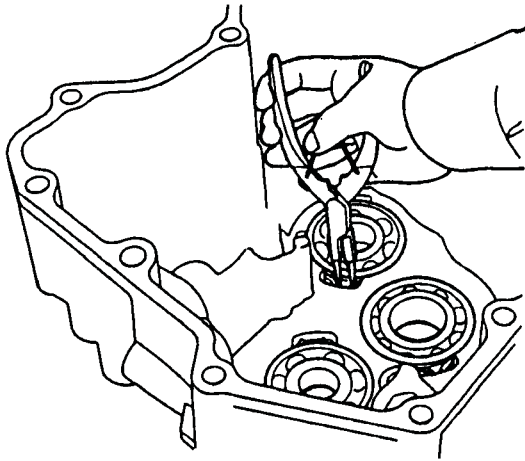
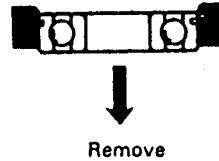

2. Expand each snap ring with snap ring pliers, insert the new bearing part-way into it, then release the pliers. Push the bearing down into the transmission until the ring snaps in place around it.

**NOTE:** Install with groove side of the housing facing inside the transmission housing.

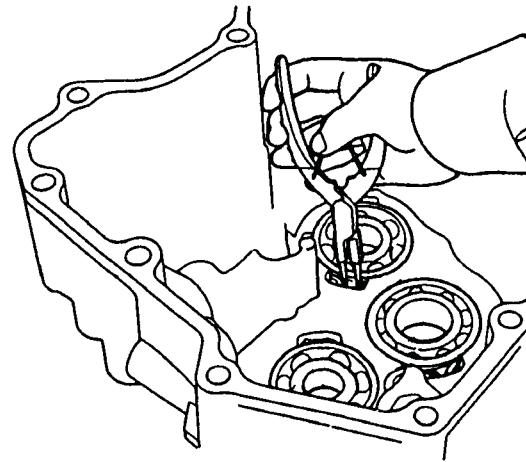
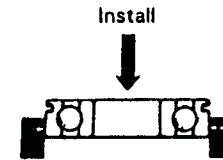

3. After installing the ball bearings, verify the following:

- The snap ring is seated in the bearing and housing grooves.
- The snap ring operates freely.
- The ring end gap is correct.

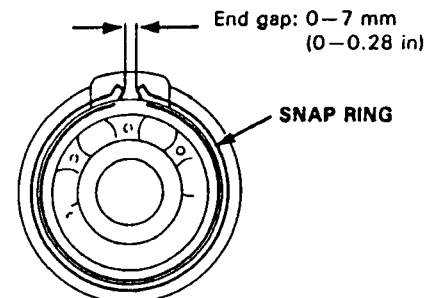

## REASSEMBLY TRANSMISSION - VALVE BODY

### NOTE:

- Coat all parts with ATF.
- Replace the below parts:
  - O-rings
  - Lock washers
  - Gaskets
  - Locknuts and conical spring washer
  - Sealing washer
- 6 x 1.0 mm Bolt Torque: 12 N·m (1.2 kg·m, 9 lb·ft)

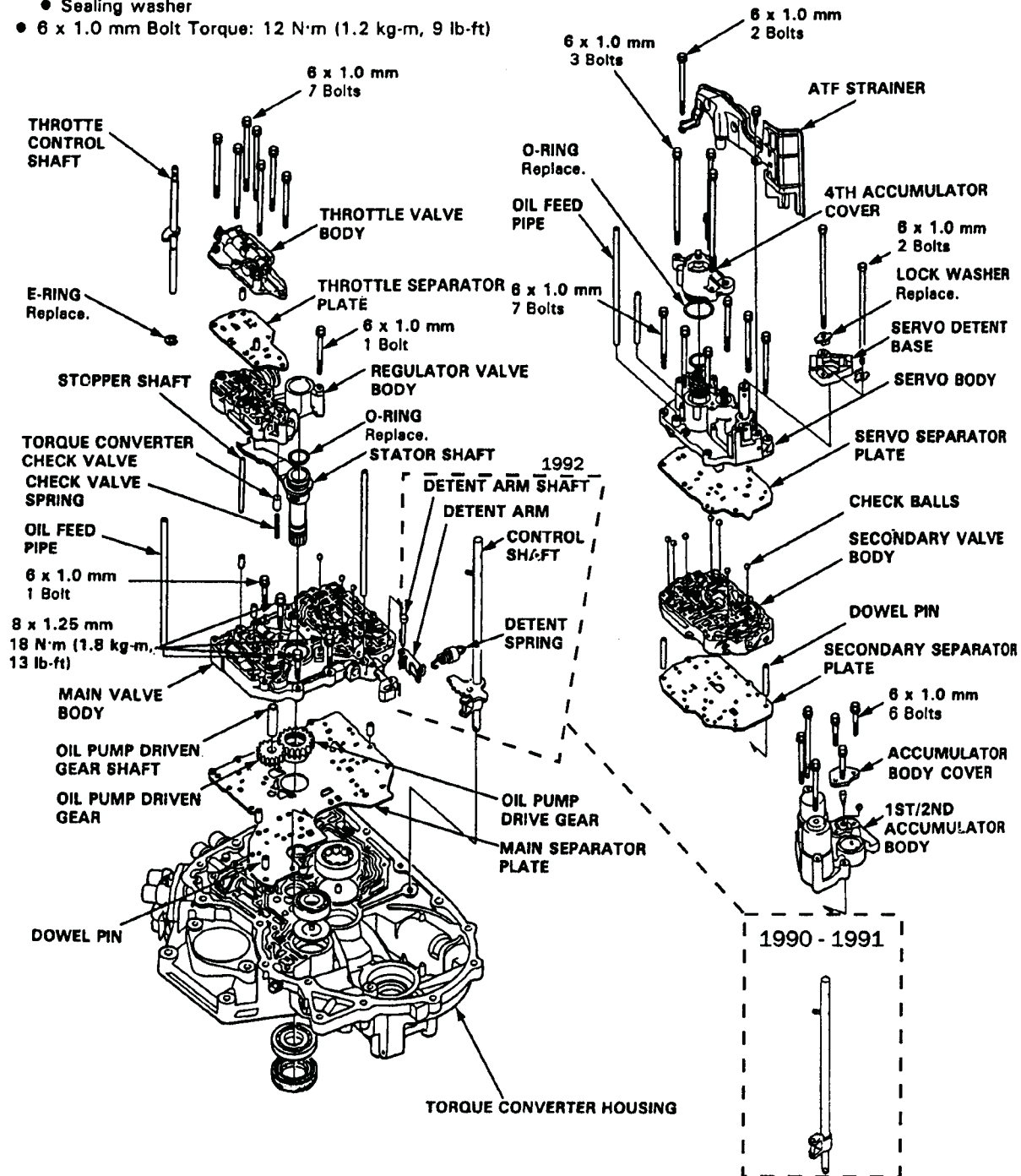

1. Install the main separator plate with 3 dowel pins on the torque converter housing. Then install the oil pump gears and oil pump driven gear shaft.

NOTE: Install the oil pump driven gear with its grooved and chamfered side facing down.

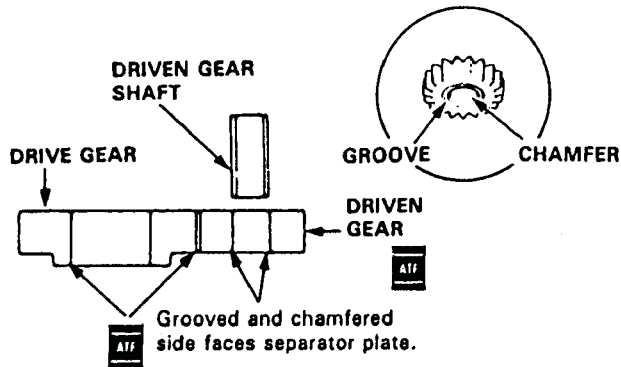

2. Install the main valve body with 4 bolts. Make sure the pump drive gear rotates smoothly in the normal operating direction and pump shaft moves smoothly in the axial and normal operating directions.
3. If the pump gear and pump shaft do not move freely, loosen the valve body bolts, realign the shaft, and then retighten to the specified torque.

**CAUTION:** Failure to align the pump shaft correctly will result in a seized pump gear or pump shaft.

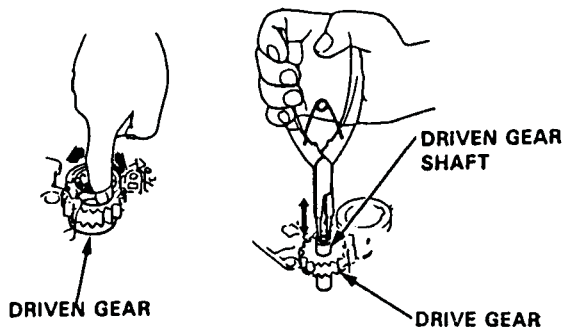

4. Install the stator shaft and stopper shaft.
5. Install the 2 dowel pins, torque converter check valve and spring in the main valve body.
6. Install the regulator valve body with 1 bolt on the main valve body.
7. Install the 2 dowel pins and separator plate on the regulator valve body, then install the throttle valve body with 7 bolts.

8. Install the secondary separator plate with 2 dowel pins on the main valve body.

9. Install the control shaft in the housing with the control shaft and manual valve together.

1992 ONLY

10. Install the detent arm and arm shaft in the main valve body, then hook the detent spring to the detent arm.

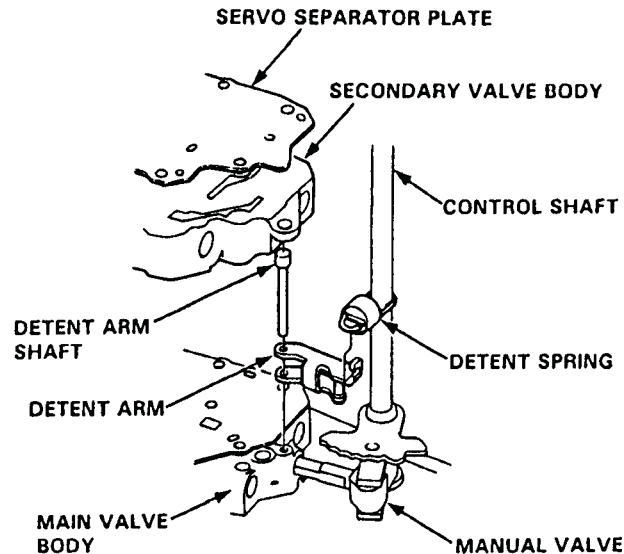

11. Install the secondary valve body, servo separator plate and servo body with 7 bolts.
12. Install the oil feed pipe in the servo body, then install the 4th accumulator cover with 3 bolts.
13. Install the ATF strainer with 2 bolts.
14. Install the servo detent base with 2 bolts and new lock washers.
15. Install the 1st/2nd accumulator body with 6 bolts.
16. Install 2 oil feed pipes in the main valve body and 1 pipe in the servo body.

17. Install the differential assembly, countershaft sub-assembly, mainshaft subassembly, and secondary shaft subassembly in the torque converter housing.

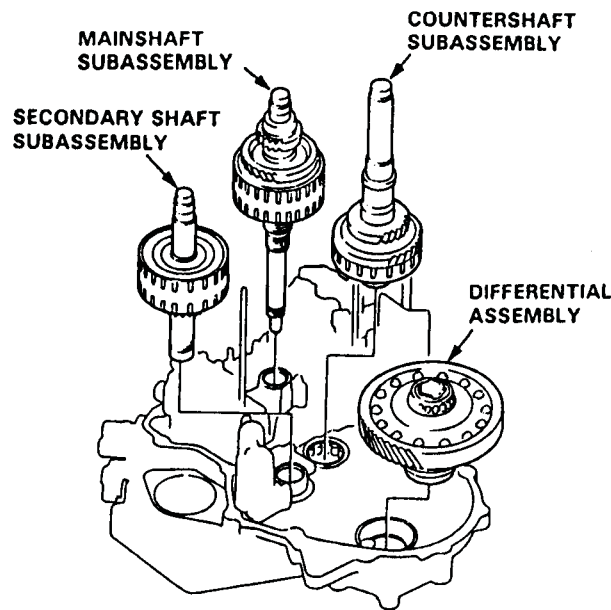

18. Install the splined washer, thrust needle bearing and needle bearings on the secondary shaft.
19. Install the needle bearings, reverse selector hub, countershaft 4th gear, and reverse selector with the shift fork on the countershaft.

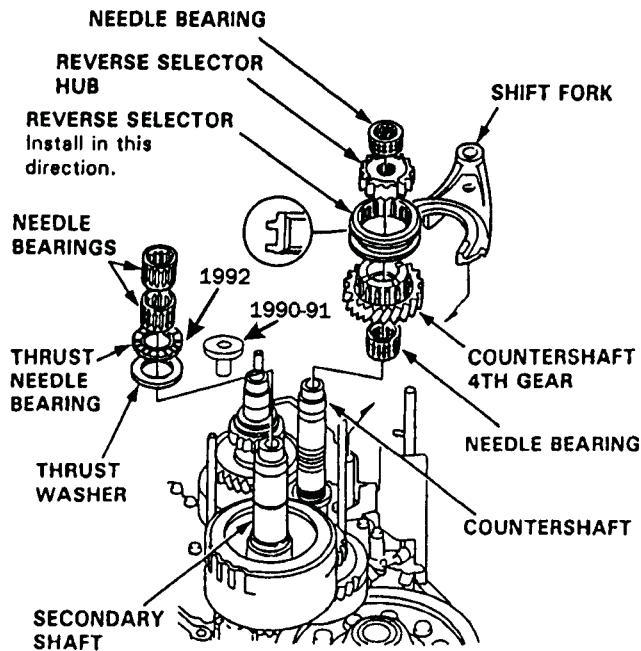

20. Turn the shift fork so the large chamfered hole is facing the fork bolt hole. Then install the shift fork and torque the lock bolt. Bend the lock tab against the bolt head.

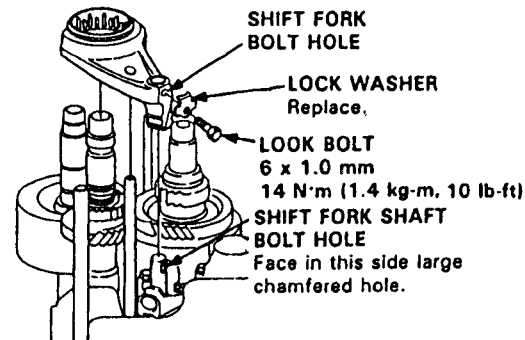

21. Install the secondary shaft 2nd gear, thrust needle bearing and thrust washer on the secondary shaft. Install the countershaft reverse gear and 2nd gear on countershaft as shown.

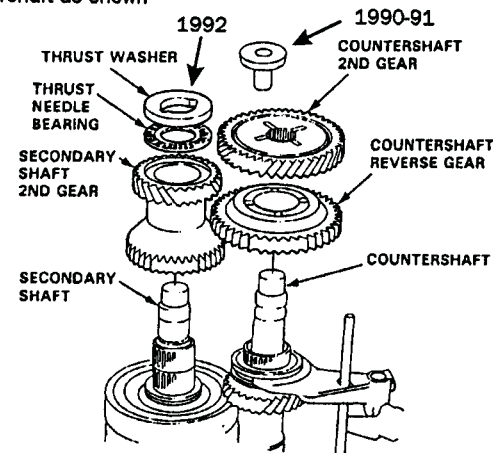

1. Press the countershaft 2nd gear into the transmission housing, using the special tool.

**1990-91 ONLY**

DRIVER 40 mm I.D.  
07746-0030100

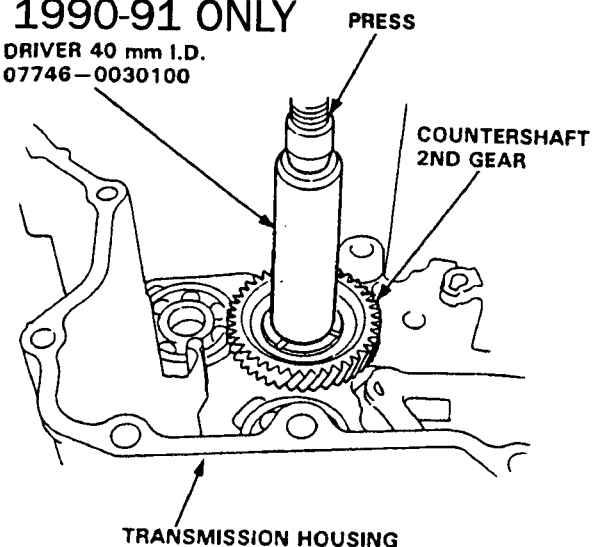

22. Slip the reverse idler gear into the transmission housing as shown.

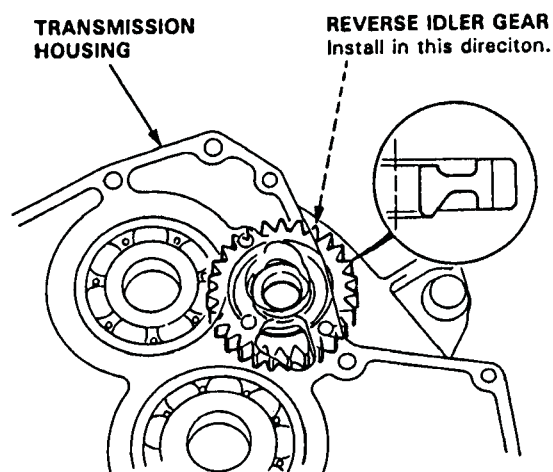

23. Align the spring pin with the transmission housing groove by turning the control shaft.

24. Place the transmission housing on the torque converter housing.

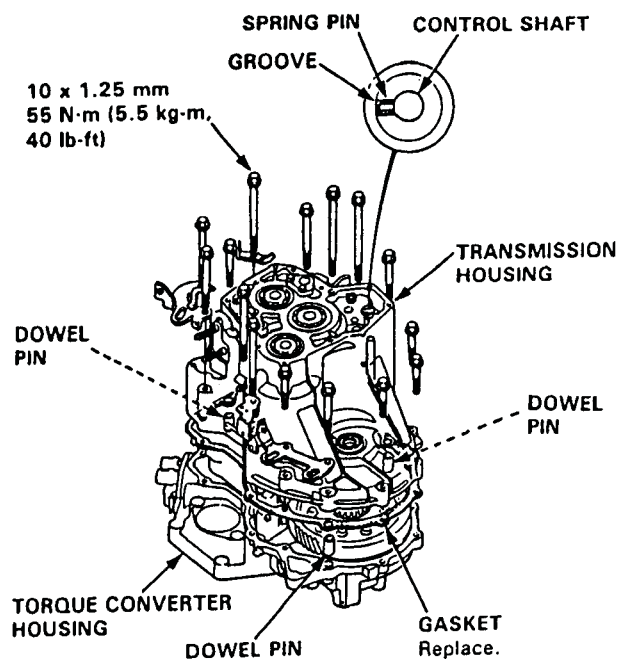

25. Install the transmission housing bolts and transmission hanger, then torque the bolts to 55 N·m (5.5 kg-m, 40 lb-ft) in two or more steps as shown.

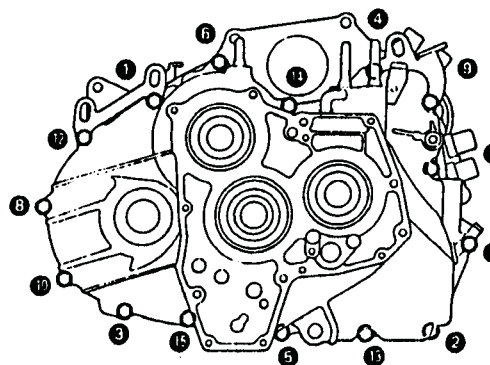

26. Engage the reverse idler gear to the countershaft reverse gear, then install the reverse idler gear shaft holder on the transmission housing.

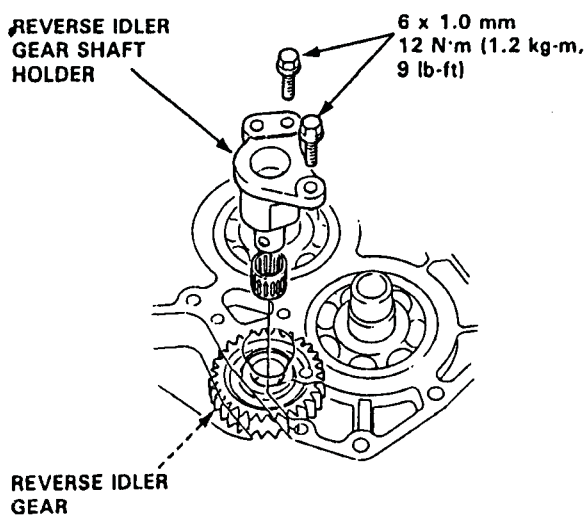

27. Install the parking brake lever on the control shaft, then torque the lock bolt. Bend the lock tab against the bolt head.

28. Slip the special tool onto the mainshaft.

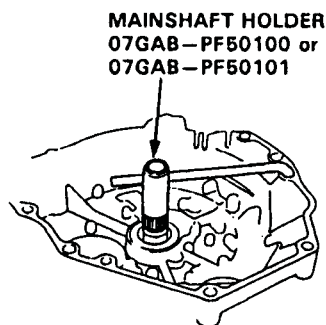

**NOTE:** Do not drive the gears on with a hammer.

29. Install the mainshaft idler gear.  
30. Install the old locknut on the mainshaft to seat the idler gear.

**NOTE:** The mainshaft locknut has left-hand threads.

**TORQUE:** 230 N·m (23.0 kg-m, 166 lb-ft)

31. Install the secondary shaft idler gear on the secondary shaft.  
32. Install the thrust washer, thrust needle bearing, needle bearing, countershaft idler gear and parking gear on the countershaft.  
33. Install the old locknut on the secondary shaft. Tighten the old locknut to seat the secondary shaft idler gear by holding the countershaft idler gear.

**TORQUE:** 230 N·m (23.0 kg-m, 166 lb-ft)

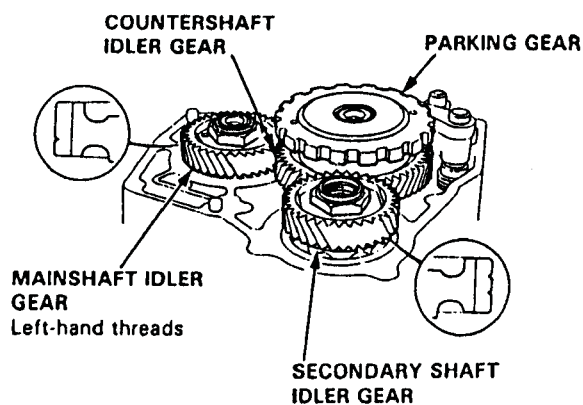

34. Place a 24 mm socket on the parking gear, and install a 10x 1.25 mm bolt in the countershaft. Then engage the parking brake pawl with the parking gear by moving up the parking brake pawl.

**CAUTION:** Keep all of the particles out of the transmission when installing a bolt.

35. Tightening the bolt and lightly seat the parking gear.  
36. Remove the bolt and socket.  
37. Install the old locknut on the countershaft to seat the parking gear.

**TORQUE:** 230 N·m (23.0 kg-m, 166 lb-ft)

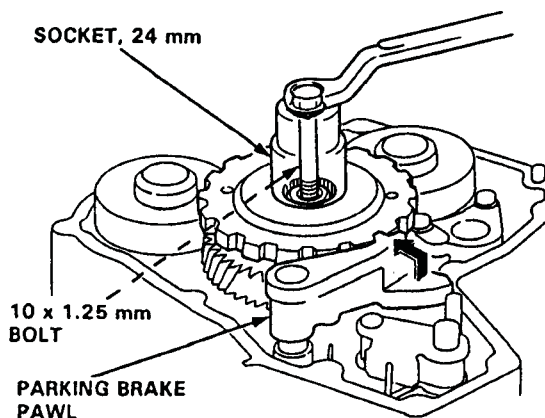

38. Remove the old locknuts, then install new conical spring washers and new locknuts on each shaft.

**CAUTION:** Install the conical spring washers in the direction shown.

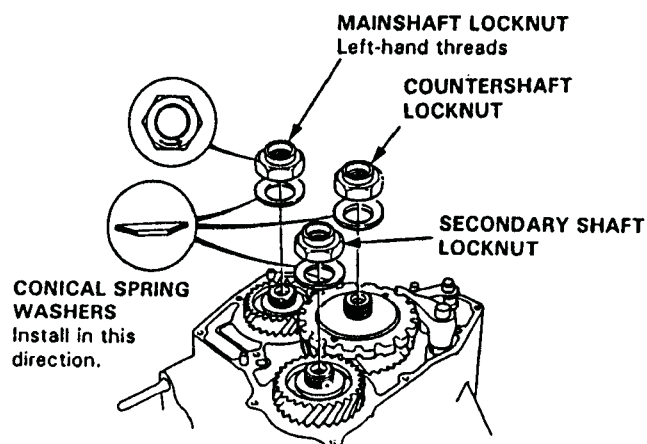

39. Tighten the locknuts to specified torque.

**TORQUE:**

**Mainshaft**

170 N·m (17.0 kg-m, 123 lb-ft)

**Countershaft**

170 N·m (17.0 kg-m, 123 lb-ft)

**Secondary shaft**

170 N·m (17.0 kg-m, 123 lb-ft)

NOTE: The mainshaft locknut has left-hand threads.

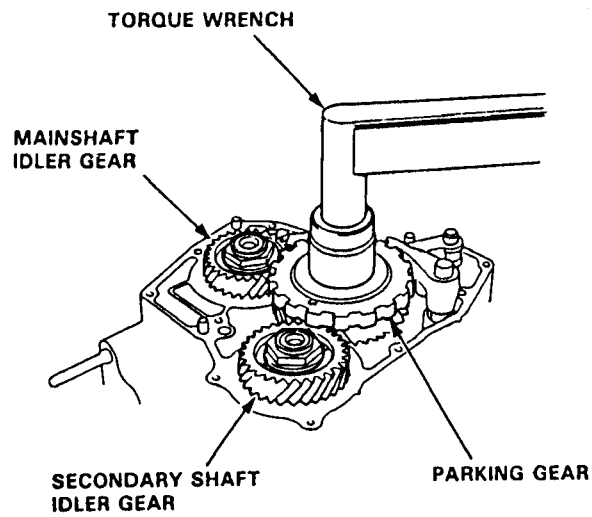

40. Stake each locknut into its shaft using a 3.5 mm punch.

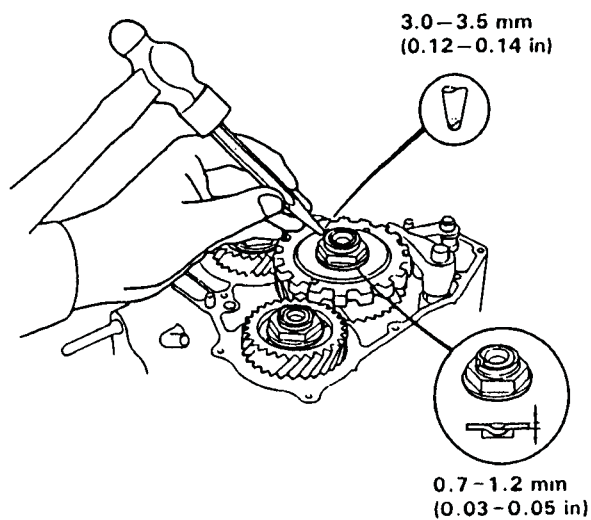

41. Set the parking brake lever in the PARK position, then verify that the parking brake pawl engages the parking gear.

42. If the pawl does not engage fully, check the parking brake pawl stopper clearance as described on

43. Tighten the lock bolt, and bend the lock tab against the bolt head.

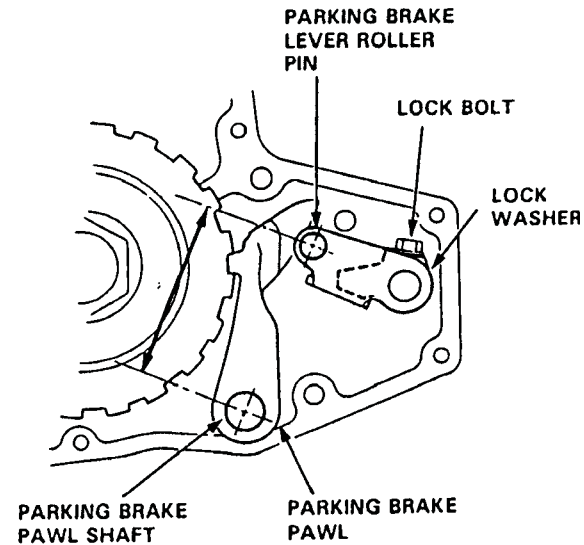

44. Install the right side cover.

**TORQUE: 12 N·m (1.2 kg-m, 9 lb-ft)**

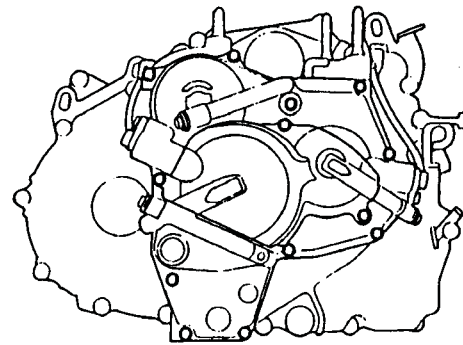

45. Install the ATF cooler pipes with new sealing washers.

**TORQUE: 29 N·m (2.9 kg-m, 21 lb-ft)**

46. Install the ATF level gauge.

## Feed Pipe Installation Right Side Cover

1. Install the feed pipes in the right side cover, aligning the lugs with the grooves in the right side over.
2. Install the snap rings.

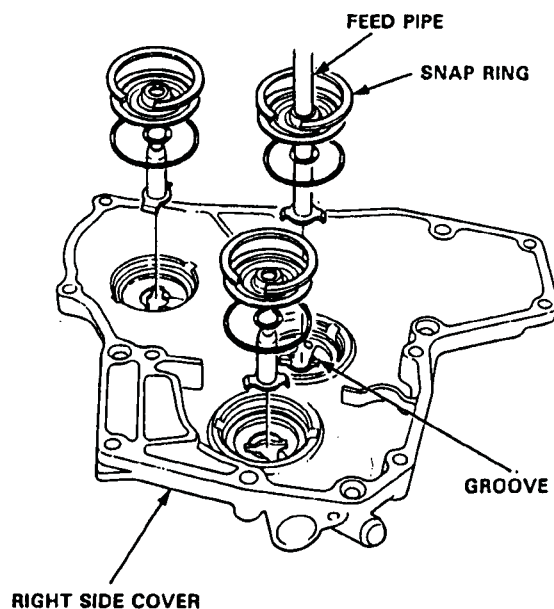

## Inspection/Adjustment Parking Brake Stopper

1. Set the parking shift arm in the PARK position.
2. Measure the distance between the parking brake pawl and the parking brake lever roller pin as shown.

STANDARD: 64.5–65.5 mm (2.54–2.58 in)

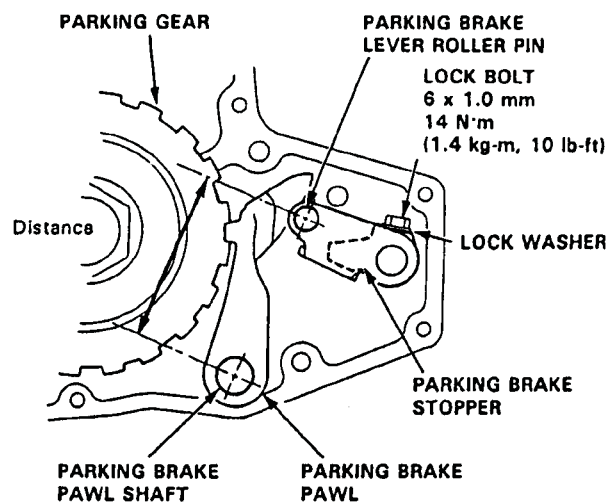

3. If the measurement is out of tolerance, select and install the appropriate parking brake stopper from the table below.

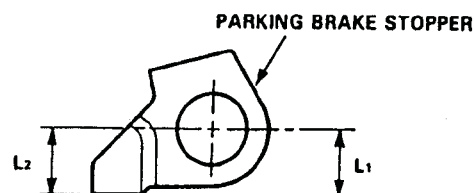

PARKING BRAKE STOPPER

Mark	Part Number	L <sub>1</sub>	L <sub>2</sub>
1	24537-PA9-003	11.00 mm (0.433 in)	11.00 mm (0.433 in)
2	24538-PA9-003	10.80 mm (0.425 in)	10.65 mm (0.419 in)
3	24539-PA9-003	10.60 mm (0.417 in)	10.30 mm (0.406 in)

4. After replacing the parking brake stopper, make sure the distance is within tolerance.

## DISASSEMBLY - TORQUE CONVERTER

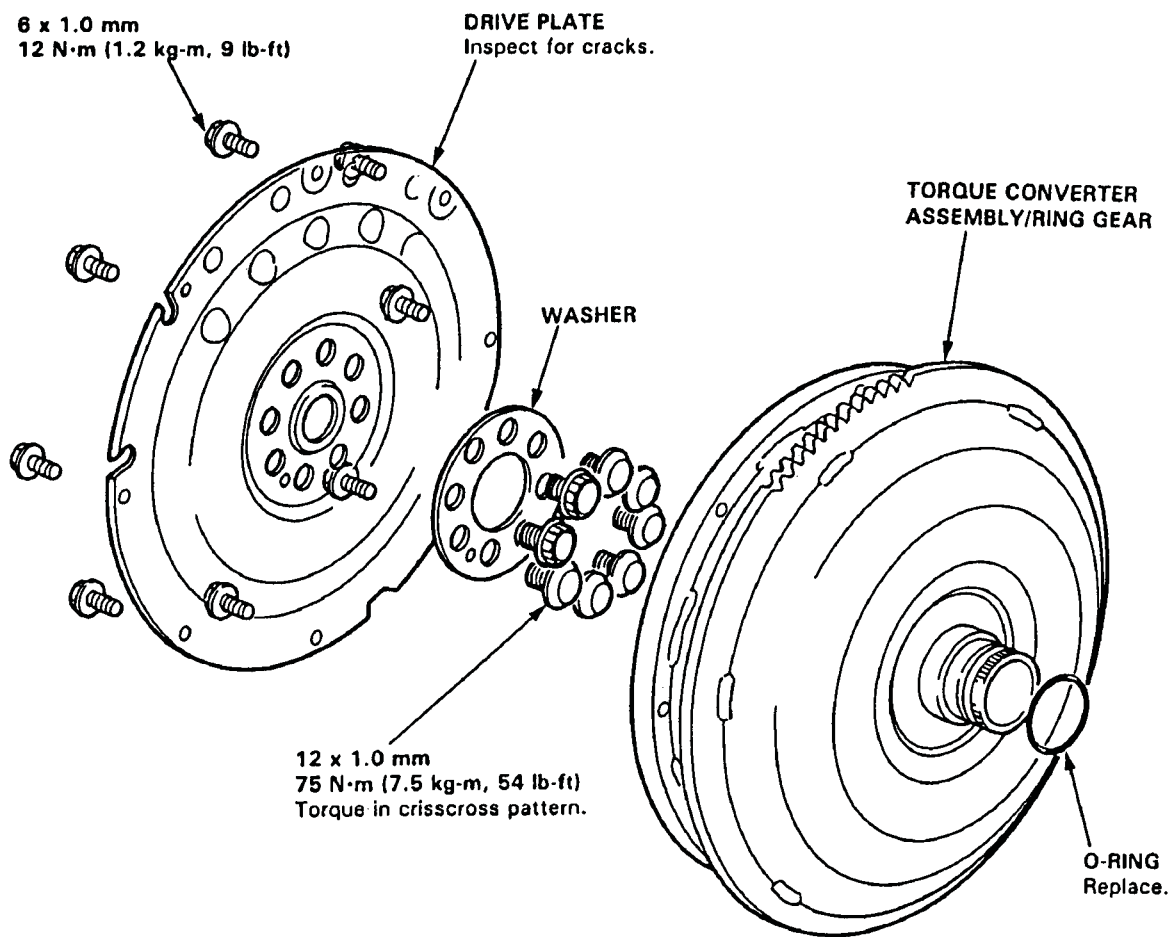

### Differential (Automatic Transmission)

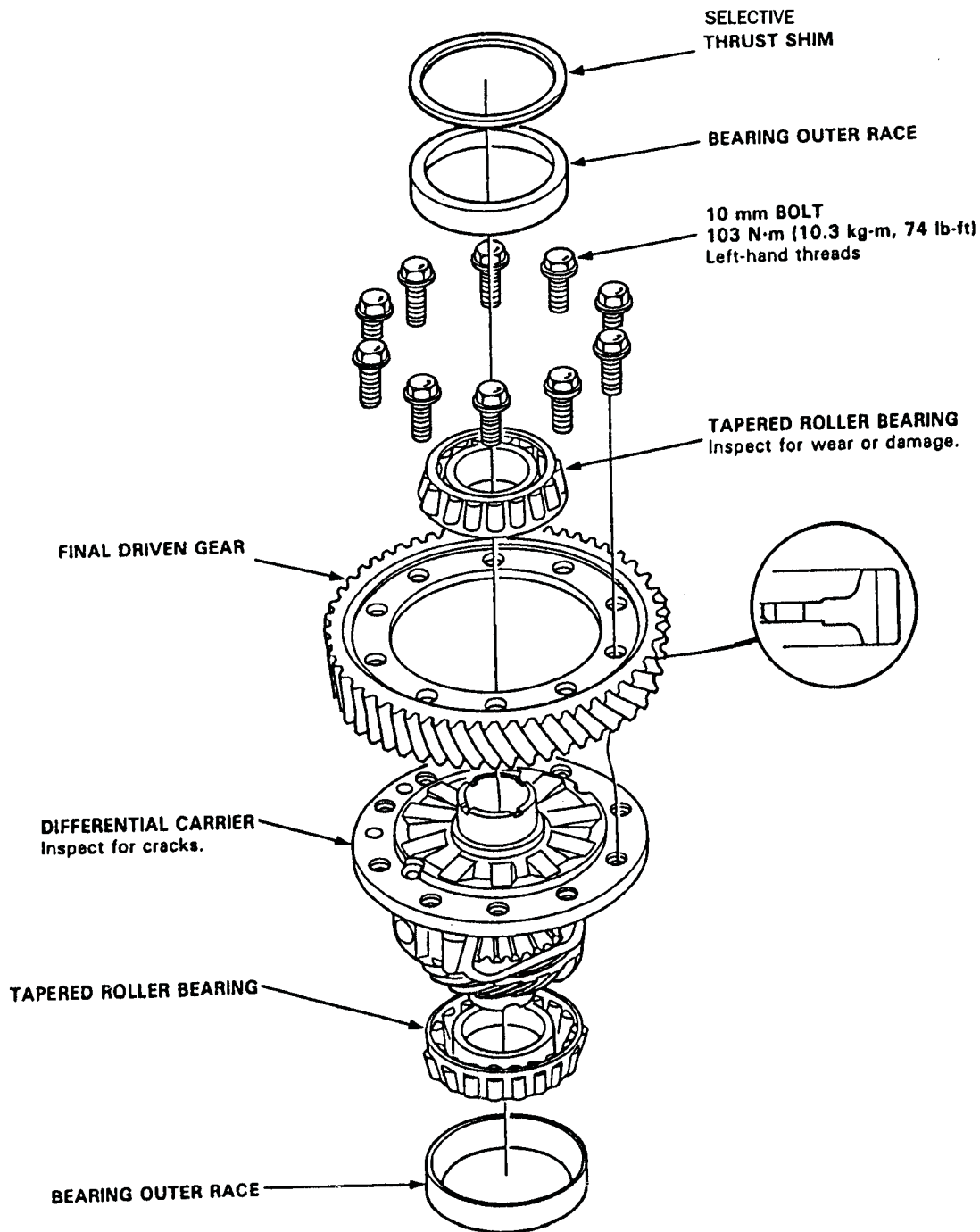

## Backlash Inspection

1. Place differential assembly on V-blocks and install both axles.
2. Check backlash of both side gears.

Standard (New): 0.08–0.15 mm  
(0.003–0.006 in.)

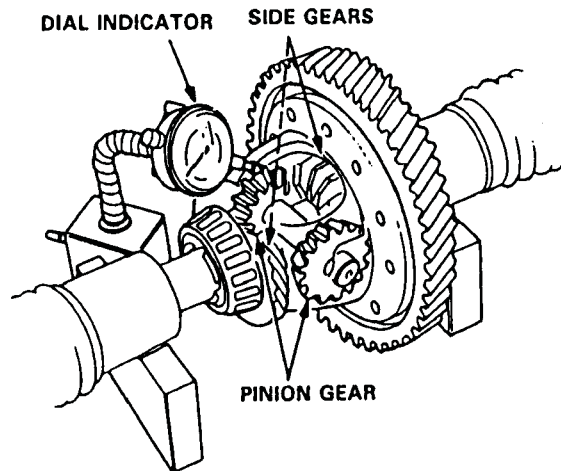

3. If the backlash is out of tolerance, replace the differential assembly.

## Bearing Replacement

NOTE: Check bearings for wear and rough rotation. If bearings are OK, removal is not necessary.

1. Remove bearings, using a standard bearing puller.

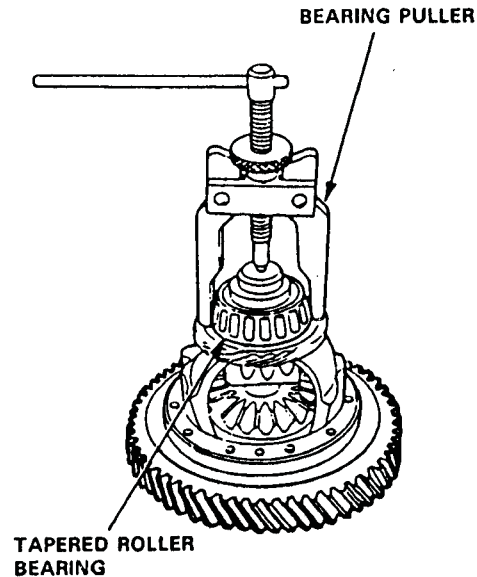

2. Install new bearings, using the special tool as shown.

NOTE:

- Drive the bearings on until they bottom.
- Use the special tool:
  - large end for torque converter housing side bearing.
  - small end for transmission housing side bearing.

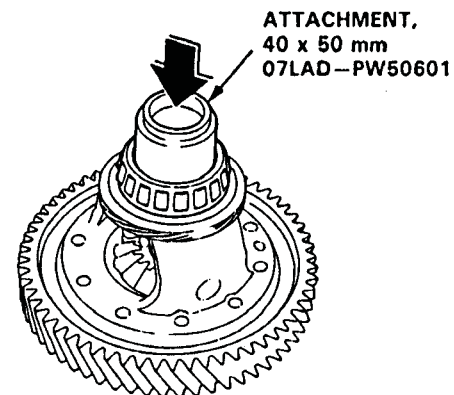

NOTE:

- The bearing and outer race should be replaced as a set.
- Inspect and adjust the bearing preload whenever a bearing is replaced.
- Drive in the bearings securely so that there is no clearance between the bearings and differential carrier.

## Differential Carrier/Ring Gear Replacement

1. Remove the ring gear from the differential carrier.

**CAUTION:** The ring gear bolts have left-hand threads.

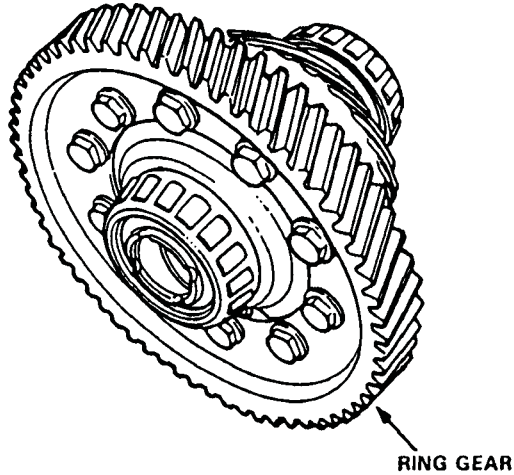

2. Install the ring gear on the differential carrier, then torque the bolts to 103 N·m (10.3 kg·m, 74 lb-ft).

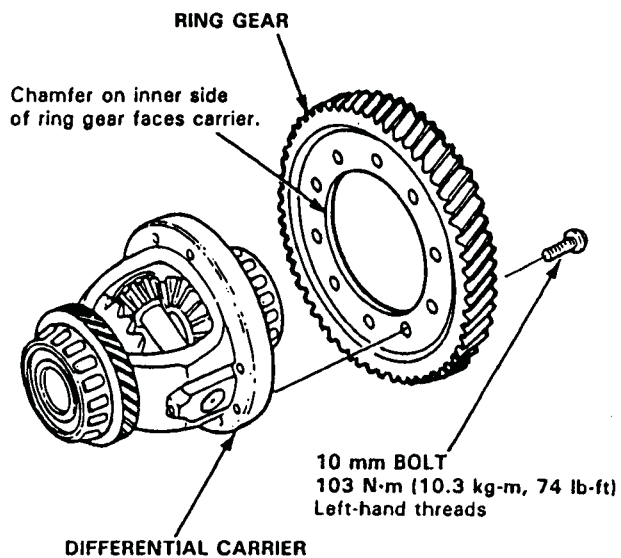

## Oil Seal Removal

1. Remove the differential assembly.
2. Remove the oil seal from the transmission housing.

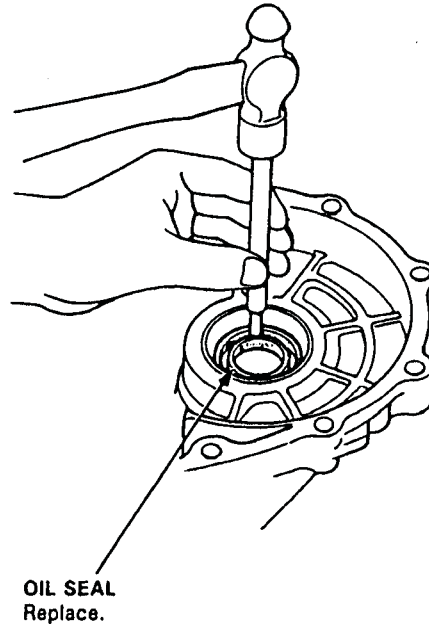

3. Remove the oil seal from the torque converter housing.

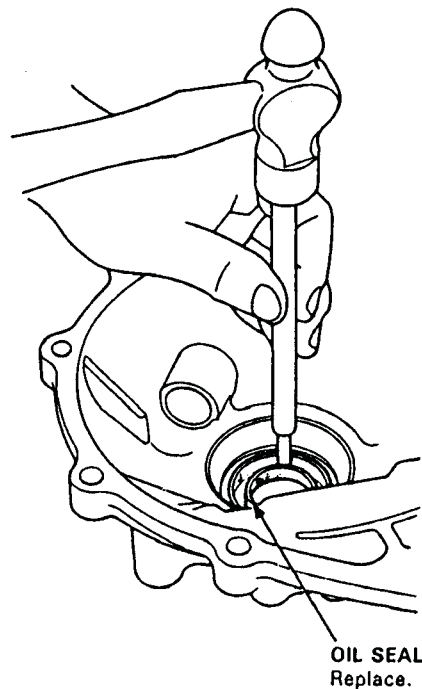

**NOTE:** If the transmission housing, torque converter housing, differential case, bearing, outer race or thrust shim were replaced, the bearing preload must be adjusted.

1. Remove the bearing outer race and thrust shim from the transmission housing by prying, or remove the outer race from the transmission housing by heating the housing to about 212°F (100°C) with a heat gun.

**CAUTION:**

- Do not heat the case in excess of 212°F (100°C).
- Replace the thrust shim with a new one if it is pried out.
- Replace the bearing when the outer race is to be replaced.
- Do not use shims on the torque converter housing side.

**NOTE:** Let the transmission housing cool to room temperature before adjusting the bearing preload.

2. Select the thrust shim(s) from the table below so that the total thickness is 2.60 mm (0.102 in).

**CAUTION:** Do not use more than two shims to adjust the bearing preload.

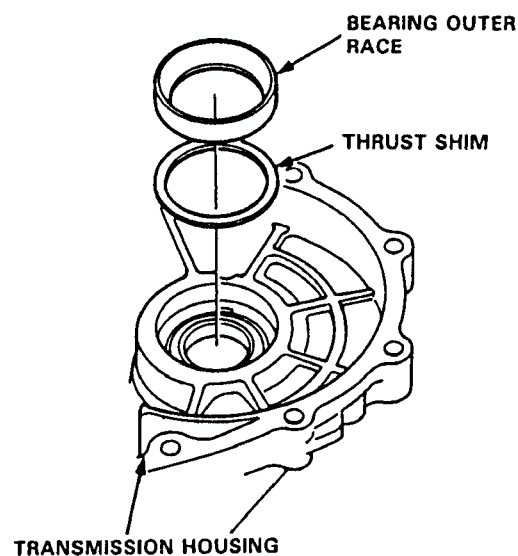

### 3. Thrust Shim Table

	Part Number	Thickness
A	41441-PK4-000	2.20 mm (0.087 in)
B	41442-PK4-000	2.25 mm (0.089 in)
C	41443-PK4-000	2.30 mm (0.091 in)
D	41444-PK4-000	2.35 mm (0.093 in)
E	41445-PK4-000	2.40 mm (0.094 in)
F	41446-PK4-000	2.45 mm (0.096 in)
G	41447-PK4-000	2.50 mm (0.098 in)
H	41448-PK4-000	2.55 mm (0.100 in)
*I	41449-PK4-000	2.60 mm (0.102 in)
J	41450-PK4-000	2.65 mm (0.104 in)
K	41451-PK4-000	2.70 mm (0.106 in)
L	41452-PK4-000	2.75 mm (0.108 in)
M	41453-PK4-000	2.80 mm (0.110 in)
N	41454-PK4-000	2.85 mm (0.112 in)
O	41456-PK4-000	2.90 mm (0.114 in)
P	41455-PK4-000	2.95 mm (0.116 in)
Q	41457-PK4-000	3.00 mm (0.118 in)
R	41458-PK4-000	3.05 mm (0.120 in)

\* Standard shim

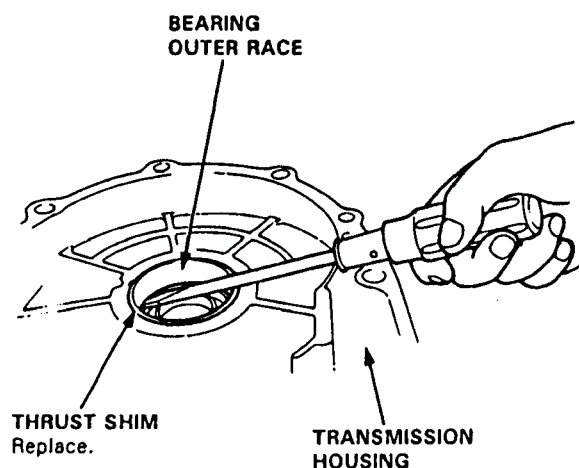

4. After installing the shim(s), install the outer race in the transmission housing, using the special tools as shown.

**CAUTION:**

- Install the outer race squarely in the transmission housing.
- Check that there is no clearance between the outer race, shim and transmission housing.
- Install the gasket when checking preload.

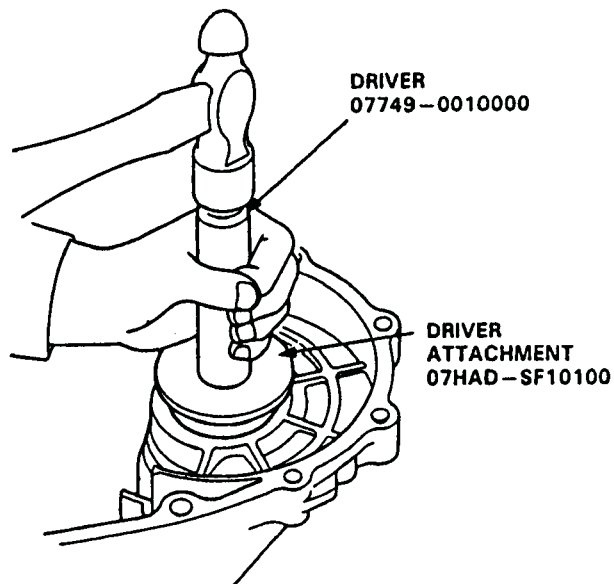

5. With the mainshaft, countershaft and secondary shaft removed, install the differential assembly and torque the transmission housing.

**TORQUE: 55 N·m (5.5 kg·m, 40 lb·ft)**

6. Rotate the differential assembly in both directions to seat the bearings.

7. Measure the starting torque of the differential assembly with the special tool and a torque wrench.

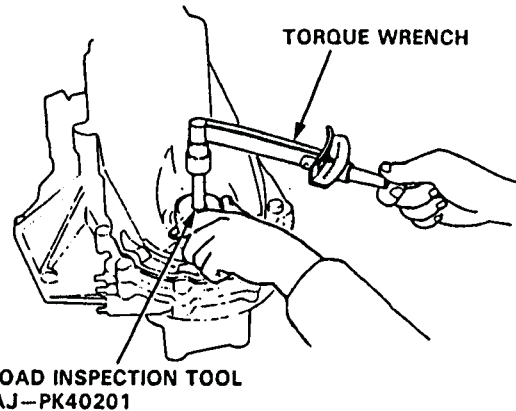

**STANDARD:**

- New bearings: 2.8–4.0 N·m  
(28–40 kg·cm, 24–35 lb·in)
- Reused bearings: 2.5–3.7 N·m  
(25–37 kg·cm, 22–32 lb·in)

**NOTE:**

- Measure the preload at normal room temperature in both directions.
- If out of spec, select two shims which will give the correct preload, and repeat steps 1–7.
- Changing one of the shims to the next size will increase or decrease preload about 3–4 kg·cm (2.60–3.47 lb·in).
- To increase the starting torque, increase the thickness of shims. To decrease the starting torque, decrease the thickness of shims.



## HONDA - ACURA 3 & 4 SPEED ALL T.V. CABLE CONTROLLED TRANSAXLES

**COMPLAINT:** Slipping, shudders, hard up or down shifts and trans failure

**CAUSE:** Improper T.V. cable timing.

**CORRECTION:** The #1 cause of transaxle problems can be corrected by properly adjusting the T.V. cable with a pressure gauge. Adjust the T.V. cable using the following procedure.

- Step 1 Connect a pressure gauge to the T.V.B. pressure tap (check service manual exact model location).
- Step 2 Warm up engine, it must be off of high idle.
- Step 3 Apply the brake and place the vehicle into D4 or S4.
- Step 4 From the drivers seat check the pressure gauge. At idle the gauge should read 0 psi, if the gauge reads more than 0 adjust the locking nut as necessary to read 0 psi.
- Step 5 With the breaks applied, gently press the accelerator untill you hear the slightest engine rpm change. At that moment the needle of the gauge must start to rise, if you don't get a pressure rise at that moment adjust as necessary.
- Step 6 Press the accelerator quickly to the floor, The pressure should rise to 100 psi then to 250 psi.