



**THM 700-R4
4L60
"1982-1986"**

INDEX

TORQUE SPECIFICATIONS	2
COMPONENT LOCATIONS	4
DESCRIPTION OF OPERATION.....	5
PRESSURE SPECIFICATIONS	6
COMPONENT APPLICATION CHART	8
GENERAL DIAGNOSIS.....	9
INTERNAL WIRING SCHEMATICS	20
PASSAGE IDENTIFICATION.....	27
TRANSMISSION DIS-ASSEMBLY.....	37
COMPONENT REPAIR AND RE-ASSEMBLY.....	48
END-PLAY CHECKS.....	76
CASE CHECK BALL LOCATIONS.....	77
VALVE BODY EXPLODED VIEWS.....	78
THRUST WASHER AND BEARING LOCATIONS	86
TECHNICAL SERVICE BULLETINS	87

AUTOMATIC TRANSMISSION SERVICE GROUP
18639 S.W. 107TH AVENUE
MIAMI, FLORIDA 33157
(305) 670-4161



INTRODUCTION

THM 700-R4 (4L60)

1982-1986

*Updated
October, 1994*

We wish to thank General Motors Corp for the information and illustrations that have made this booklet possible. The THM 700-R4 transmission is a fully automatic unit consisting of a 3 element torque converter with the addition of a converter clutch. Five multiple disc clutch packs, one roller clutch, one sprag and one band provide the friction elements required to obtain the desired function of the compound planetary gear set. The combination of these elements provides four forward speeds with 4th gear being overdrive, and reverse. Changing of the gear ratios is fully automatic in relation to vehicle speed and engine torque. Vehicle speed and engine torque signals are constantly fed to the transmission, to provide the proper gear ratio for maximum efficiency and performance at all throttle openings.

No part of any ATSG publication may be reproduced, stored in any retrieval system or transmitted in any form or by any means, including but not limited to electronic, mechanical, photocopying, recording or otherwise, without *written* permission of Automatic Transmission Service Group. This includes all text illustrations, tables and charts.

"Portions of materials contained herein have been reprinted under license from General Motors Corp, Service & Parts Operations."

The information and part numbers contained in this booklet have been carefully compiled from industry sources known for their reliability, but ATSG does not guarantee its accuracy.

Copyright © ATSG 1993

DALE ENGLAND
FIELD SERVICE CONSULTANT

WAYNE COLONNA
TECHNICAL SUPERVISOR

PETER LUBAN
TECHNICAL CONSULTANT

JON GLATSTEIN
TECHNICAL CONSULTANT

ROLAND ALVAREZ
TECHNICAL CONSULTANT

GERALD CAMPBELL
TECHNICAL CONSULTANT

JIM DIAL
TECHNICAL CONSULTANT

ED KRUSE
TECHNICAL CONSULTANT

GREGORY LIPNICK
TECHNICAL CONSULTANT

DAVID CHALKER
TECHNICAL CONSULTANT

JERRY GOTT
TECHNICAL CONSULTANT

MIKE SOUZA
TECHNICAL CONSULTANT



Technical Service Information

LOCATION	QUANTITY	SIZE	TORQUE
ACCUMULATOR COVER TO CASE	2	1.0 X 30.3	(8 FT. LB.)
ACCUMULATOR COVER TO CASE	1	1.0 X 60.0	(8 FT. LB.)
DETENT SPRING TO VALVE BODY	1	1.75 X 20.0	(18 FT. LB.)
VALVE BODY TO CASE	15	1.0 X 50.0	(8 FT. LB.)
OIL PASSAGE COVER TO CASE	3	1.0 X 16.0	(8 FT. LB.)
SOLENOID ASSEMBLY TO PUMP	2	1.0 X 12.0	(8 FT. LB.)
TRANSMISSION OIL PAN TO CASE	16	1.25 X 16	(12 FT. LB.)
PRESSURE SWITCHES	1 to 3	1/8" - 27	(8 FT. LB.)
PARK BRAKE BRACKET TO CASE	2	1.25 X 20.00	(18 FT. LB.)
PUMP COVER TO BODY	5	1.25 X 40.00	(18 FT. LB.)
PUMP ASSEMBLY TO CASE	7	1.25 X 60	(18 FT. LB.)
CASE EXTENSION TO CASE	4	1.50 X 30.0	(26. FT. LB.)
MANUAL SHAFT TO INSIDE DETENT LEVER	1	1.50 NUT	(23 FT. LB.)
PRESSURE PLUGS	4	1/8" - 27	(8 FT. LB.)
PRESSURE PLUGS	3	1/4" - 18	(18 FT. LB.)
CONNECTOR COOLER PIPE	2	1/4" - 18	(28 FT. LB.)

AUTOMATIC TRANSMISSION SERVICE GROUP

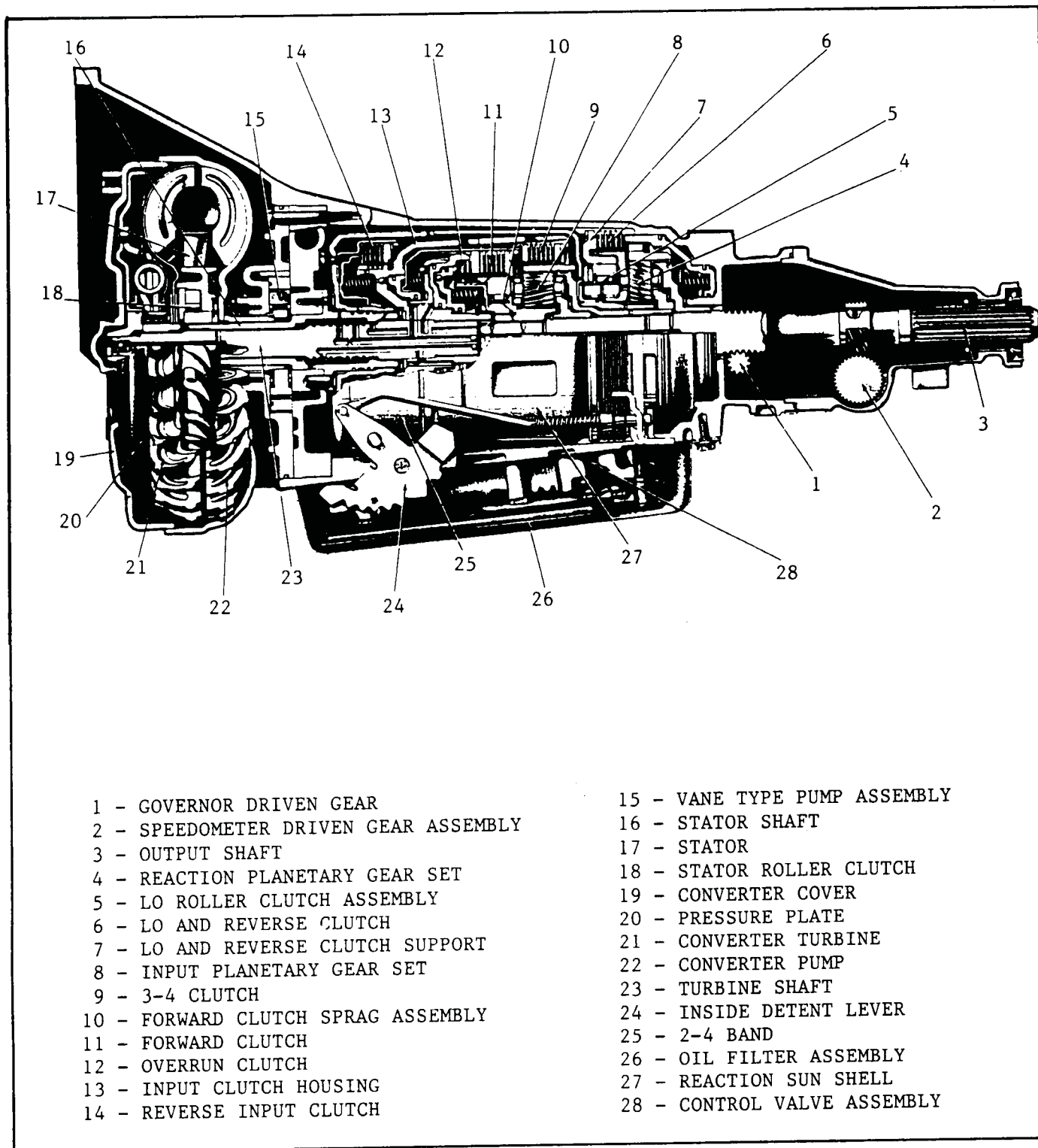

FIGURE 1

AUTOMATIC TRANSMISSION SERVICE GROUP

GENERAL DESCRIPTION

The THM 700-R4 is a fully automatic transmission for rear wheel drive vehicles which provides four forward ranges and a reverse range.

The major components of this transmission are:

1. Torque Converter Clutch Assembly
2. Vane Type Oil Pump
3. 2-4 Band Assembly
4. Five Multiple Disc Clutches
5. Two Planetary Gear Sets
6. One Sprag Clutch
7. One Roller Clutch
8. Valve Body Assembly

The oil pressure and shift points are controlled by throttle opening via a throttle valve cable.

The Transmission can be operated in any of seven different modes shown on the shift quadrant. (See Figure 2)

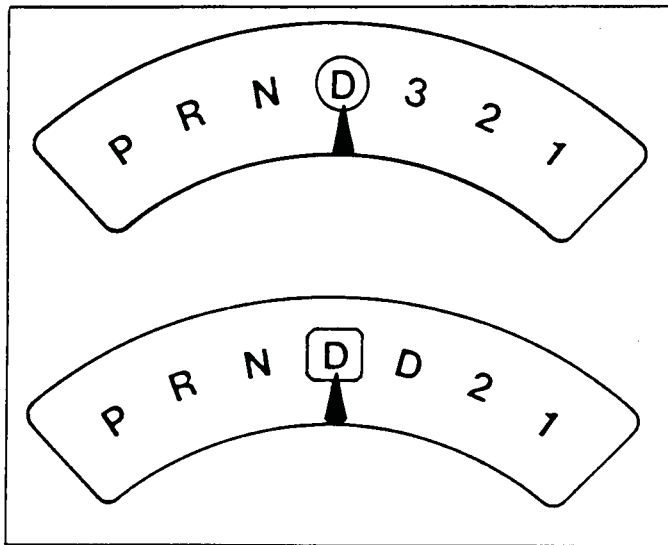

Figure 2

P - Park position prevents the vehicle from rolling either forward or backward. (For safety reasons the parking brake should be used in addition to the park position).

R - Reverse allows the vehicle to be operated in a rearward direction.

N- Neutral allows the engine to be started and operated without driving the vehicle. If necessary this position may be selected if the engine must be restarted with the vehicle moving.

D or **D** - Overdrive is used for all normal driving conditions. It provides four gear ratios plus converter clutch operation. Downshifts are available for safe passing by depressing the accelerator.

D or 3 - Drive position is used for city traffic, hilly terrain, and trailer towing. It provides three gear ranges plus converter clutch operation. Again, downshifts are available by depressing the accelerator.

2 - Manual second is used to provide acceleration and engine braking. This range may be selected at any vehicle speed.

1 - Manual Lo is used to provide maximum engine braking. This range may also be selected at any vehicle speed, but will only downshift below approximately 40 MPH.

DIAGNOSIS INFORMATION

ROAD TEST PROCEDURE

Overdrive Range:

While stopped, position the range selector lever in overdrive range and accelerate. Check for a 1-2, 2-3 and 3-4 upshift. (Shift points will vary with throttle position.) Also, the converter clutch may apply in 2nd or 3rd gear depending on calibration. Check for part throttle downshifts by depressing the throttle to a 3/4 open position. Check for detent downshifts by depressing the accelerator to wide open position at various speeds.

Drive Range:

At road speed in fourth gear (overdrive range), manually shift the transmission to drive range. The transmission should shift back to 4th gear range. Check for part throttle and detent downshifts.

Drive 2:

While in 3rd gear range, shift to manual second; the transmission should downshift immediately. Test for a 2-1 detent downshift.

Lo Range:

Position the selector lever in lo range and check operation. (In some vehicles it may be possible to obtain a 1-2 upshift while in this gear range.)

Overrun Braking:

Overrun braking can be checked by manually downshifting to a lower gear range. Engine R.P.M.'s should increase and a braking effect should be noticed.

Reverse:

Position the selector lever in reverse and check reverse operation.

THM 700-R4

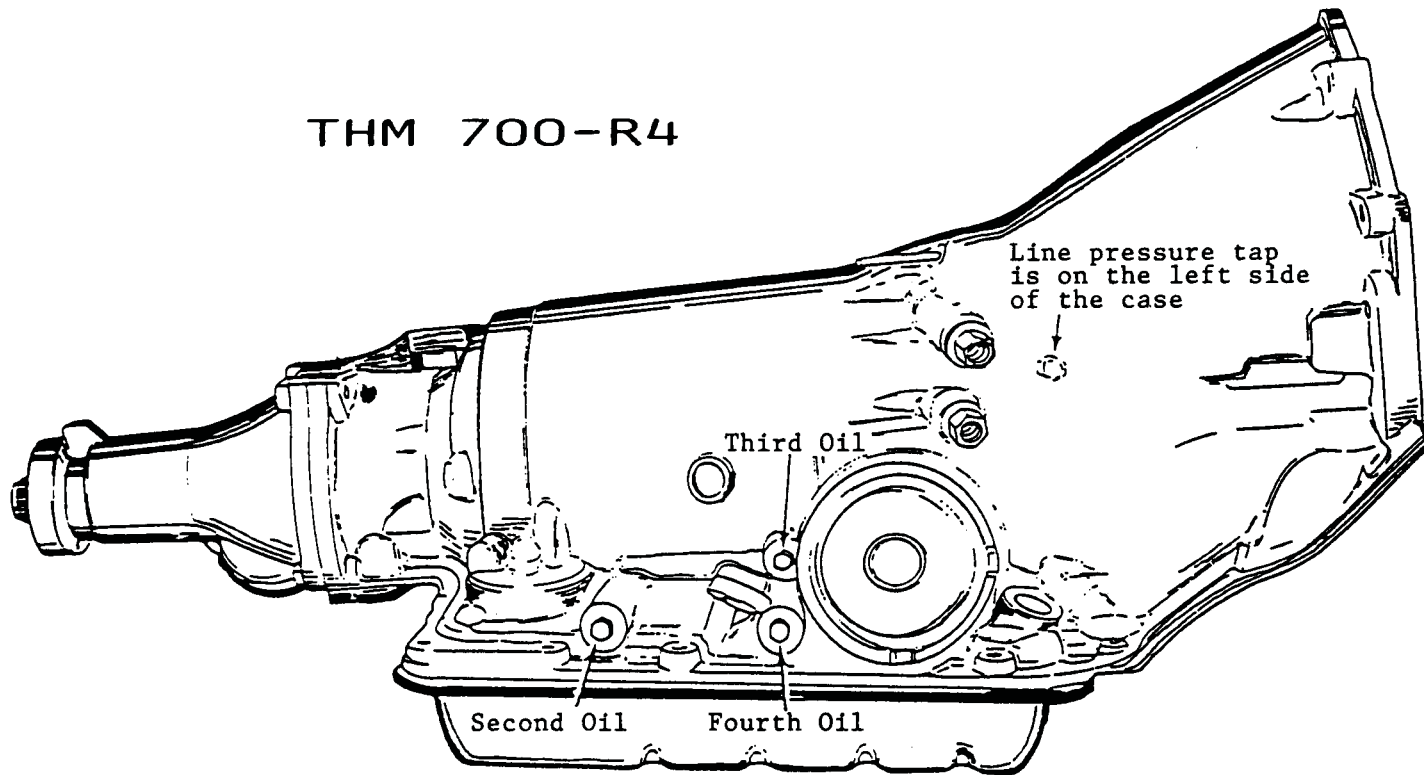

OIL PRESSURE TAP LOCATIONS

NOTE: AS A DIAGNOSIS AID, YOU CAN CHECK THE OIL PRESSURE DIFFERENTIAL BETWEEN LINE PRESSURE AND THE 2ND, 3RD AND 4TH CLUTCH PRESSURE WHILE DRIVING THE VEHICLE. IF THE PRESSURE DIFFERENTIAL BETWEEN LINE PRESSURE AND ANY OF THE CLUTCH CIRCUITS IS MORE THAN 10 P.S.I (PROVIDED YOUR GAGES ARE ACCURATE), THERE IS A POSSIBLE LEAK IN THAT CLUTCH OIL CIRCUIT.

FIGURE 3

OIL PRESSURE CHECK INFORMATION

PRELIMINARY CHECK PROCEDURE

- CHECK TRANSMISSION OIL LEVEL
- CHECK AND ADJUST T.V. CABLE
- CHECK OUTSIDE MANUAL LINKAGE AND CORRECT
- CHECK ENGINE TUNE
- INSTALL OIL PRESSURE GAGE
- CONNECT TACHOMETER TO ENGINE
- CHECK OIL PRESSURE AS FOLLOWS:

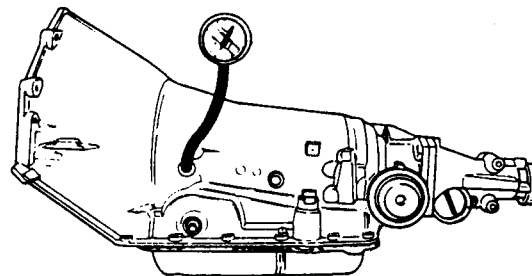

ATTACH PRESSURE GAGE

Minimum T.V. Line Pressure Check

Set the T.V. cable to specification; and with the brakes applied, take the line pressure readings in the ranges and at the engine r.p.m.'s indicated in the chart below.

Full T.V. Line Pressure Check

Full T.V. line pressure readings are obtained by tying or holding the T.V. cable to the full extent of its travel; and with the brakes applied, take the line pressure readings in the ranges and at the engine r.p.m.'s indicated in the chart below.

***NOTICE** Total running time for this combination not to exceed 2 minutes.

CAUTION Brakes must be applied at all times.

AUTOMATIC TRANSMISSION OIL PRESSURES

RANGE	MODEL	NORMAL OIL PRESSURE AT MINIMUM T.V.		NORMAL OIL PRESSURE AT FULL T.V.	
		kPa	PSI	kPa	PSI
PARK, NEUTRAL, OVERDRIVE & MANUAL 3RD @ 1000 RPM	YT	384-444	56-64	818-1040	119-151
	YL	384-444	56-64	838-1085	122-157
	YK,YN,YP	384-444	56-64	898-1164	130-169
	TS	384-444	56-64	962-1237	140-179
	YS	384-444	56-64	1020-1388	148-201
	YA, YC, YD, YW, YZ	384-444	56-64	1039-1369	151-199
	TA, TB	451-515	65-75	792-998	115-145
	FA, MH, TN, TR, TW	451-515	65-75	827-1086	120-158
	YX	451-515	65-75	838-1057	122-153
	TL, YF	451-515	65-75	886-1176	128-171
	MA, MC, MF, MJ, MK, MM, MP, MR, MT, MW, MX, PR, TJ, TK	451-515	65-75	905-1157	131-168
	TC, TD, TF	451-515	65-75	964-1235	140-179
REVERSE @ 1000 RPM * @ 2000 RPM	YT	632-730	92-106	*1345-1710	195-248
	YL	632-730	92-106	*1377-1785	200-259
	YK, YN, YP	632-730	92-106	*1476-1914	214-278
	TS	632-730	92-106	*1581-2034	229-295
	YS	632-730	92-106	*1677-2284	243-331
	YA, YC, YD, YW, YZ	632-730	92-106	*1708-2251	248-326
	TA, TB	742-846	108-123	*1302-1640	189-238
	FA, MH, TN, TR, TW	742-846	108-123	*1358-1786	197-259
	YX	742-846	108-123	*1376-1736	200-252
	TL, YF	742-846	108-123	*1456-1933	211-280
	MA, MC, MF, MJ, MK, MM, MP, MR, MT, MW, MX, PR, TJ, TK	742-846	108-123	*1487-1902	216-276
	TC, TD, TF	742-846	108-123	*1585-2030	230-294
MANUAL 2ND & MANUAL LO @ 1000 RPM	YT	605-698	88-101	605-698	88-101
	MH, TN, TR, TW	644-736	93-107	644-736	93-107
	TS, YA, YC, YD, YK, YL, YN, YP, YS, YW, YZ	705-814	102-118	705-814	102-118
	FA, MA, MC, MF, MJ, MK, MM, MP, MR, MT, MW, PR, TA, TB, TC, TD, TF, TJ, TK, TL, TZ, YF, YX	710-810	103-117	710-810	103-117

Line pressure is basically controlled by pump output and the pressure regulator valve. In addition, line pressure is boosted in Reverse, Second and Lo by the reverse boost valve.

Also, in the Neutral, Drive, Intermediate and Reverse positions of the selector lever, the line pressure should increase with throttle opening because of the T.V. system. The pressure is controlled by the T.V. cable, the throttle lever and bracket assembly and the T.V. link, as well as the control valve assembly.

The main line pressure tap plug is located on the left side of the transmission above the outside manual lever.

THM 700-R4

FIRST	3.06	} GEAR RATIOS
SECOND	1.62	
THIRD	1.00	
FOURTH	.70	
REVERSE	2.29	

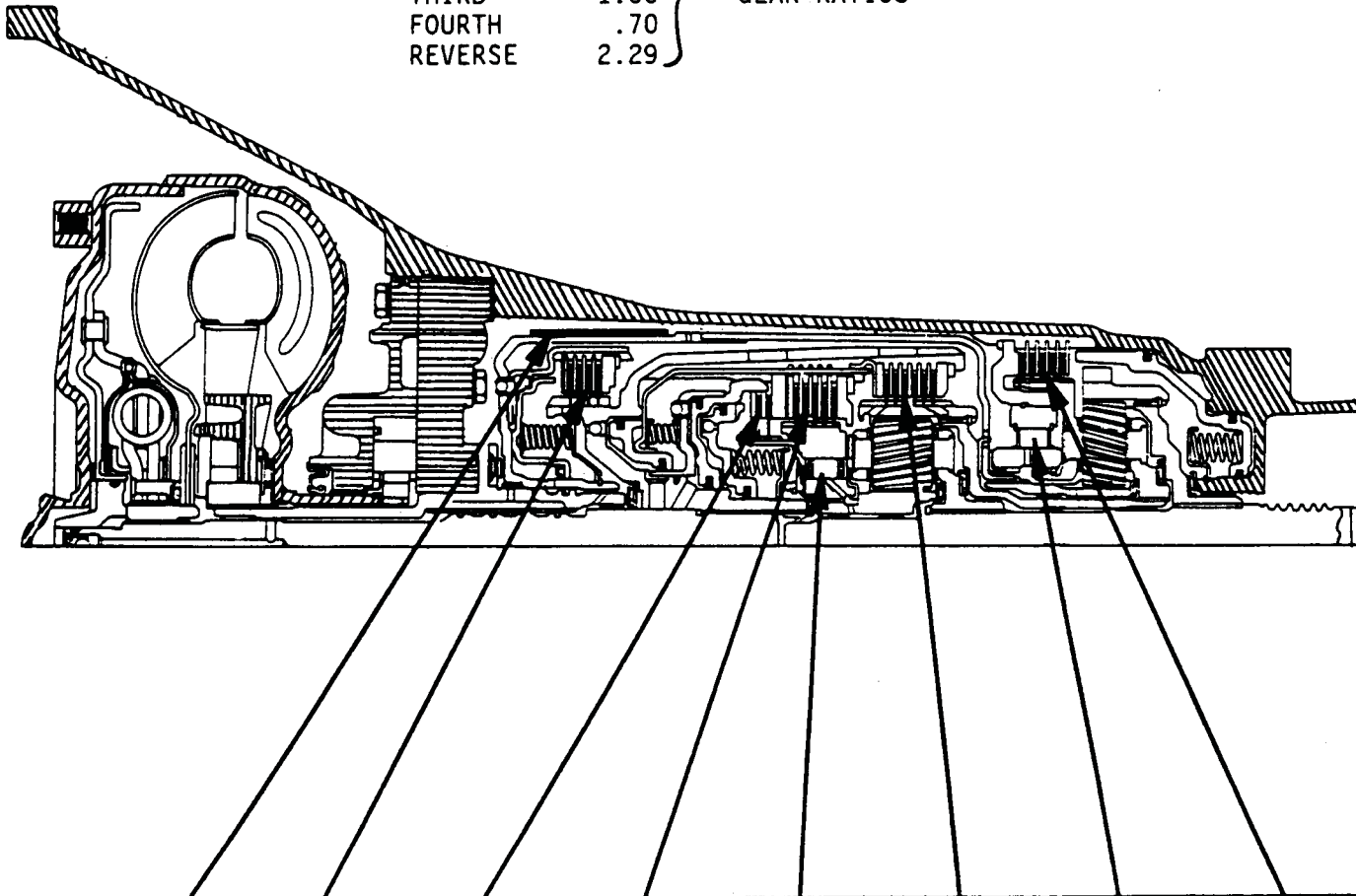

GEAR RANGE	2-4 BAND	REVERSE INPUT CLUTCH	OVERRUN CLUTCH	FORWARD CLUTCH	FORWARD SPRAG CL. ASSEMBLY	3-4 CLUTCH	LO ROLLER CLUTCH	LO-REV. CLUTCH
1ST DR4				ON	ON		ON	
2ND DR4	ON			ON	ON			
3RD DR4				ON	ON	ON		
4TH DR4	ON			ON		ON		
3RD DR3			ON	ON	ON	ON		
2ND DR2	ON		ON	ON	ON			
1ST LO			ON	ON	ON		ON	ON
REV.		ON						ON

Figure 4

AUTOMATIC TRANSMISSION SERVICE GROUP

GENERAL DIAGNOSIS GUIDE

COMPLAINT	INSPECT	CAUSE
<p>OIL LEAK</p> <p>To Correctly Identify Oil Leaks, Perform the Following Procedure:</p> <ol style="list-style-type: none"> 1. Clean all residual oil from the transmission with electric cleanser or equivalent. 2. Dust the transmission with leak tracing powder or spray foot powder. 3. Bring the engine to normal operating temperature. 4. Turn the engine off and let the vehicle set for thirty minutes. 5. Check for leaks. 	<ol style="list-style-type: none"> 1. Oil Pan 2. T.V. Cable Connector 3. Fill Tube 4. Electrical Connector 5. Manual Shaft 6. Governor Cover 7. Speedo Fitting 8. Servo Cover 9. Cooler Fittings 10. Converter Assembly 11. Vent 12. Oil Pump Assembly 13. Rear Extension 	<ul style="list-style-type: none"> - Low bolt torque. - Cut or damaged oil pan gasket. - Connector cocked and interfering with mount. - Connector cracked. - Seal missing, cut or damaged. - Fill tube cracked or damaged. - Seal missing, cut, or damaged. - Electrical connector cracked. - Seal missing, cut or damaged. - Manual shaft nicked or damaged. - Manual shaft seal assembly missing, cut or damaged. - Gaps in sealant. (Remove & Reseal.) - Low bolt torque. - Seal missing, cut or damaged. - Porosity. - Sharp edges on case cut "O" ring seal. - Low torque. - Cracked fitting. - Hub or seam weld leak. - Oil overfill. - Engine coolant in transmission oil. - Low bolt torque. - Cut or damaged oil pump to case seal. - Damaged seal. (Restricted drainback passage.) - Porosity. - Damaged extension to case seal. - Porosity. - Damaged oil seal assembly.

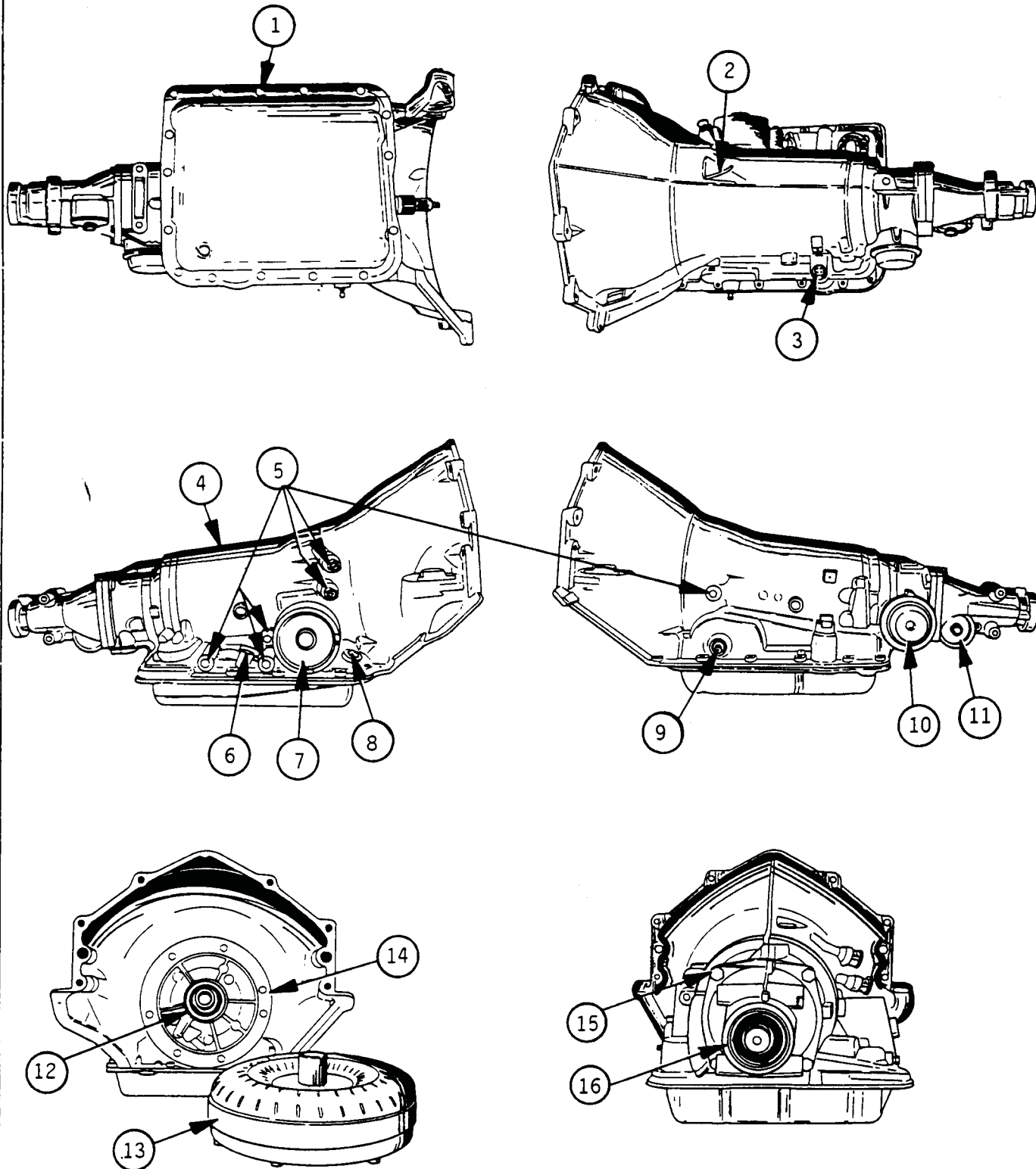

- | | | |
|-------------------------------|----------------------|-----------------------------|
| 1. OIL PAN | 6. T.V. CABLE SEAL | 12. FRONT PUMP SEAL |
| 2. VENT | 7. SERVO COVER SEAL | 13. CONVERTER ASSEMBLY |
| 3. CASE CONNECTOR
"O" RING | 8. FILLER TUBE SEAL | 14. FRONT PUMP "O" RING |
| 4. CASE | 9. MANUAL SHAFT SEAL | 15. EXTENSION HSG. "O" RING |
| 5. COOLER FITTINGS &
PLUGS | 10. GOVERNOR COVER | 16. REAR SEAL ASSEMBLY |
| | 11. SPEEDO SEALS | |

Figure 5

COMPLAINT	INSPECT	CAUSE
OIL PRESSURE HIGH OR LOW	1. Oil Pump Assembly 2. Oil Filter 3. T.V. Exhaust Ball 4. Throttle Lever & Bracket Assy. 5. Throttle Link 6. Valve Body 7. Case	<ul style="list-style-type: none"> - Pressure regulator valve stuck. - Pressure regulator valve spring damaged. - Rotor guide omitted or misassembled. - Rotor cracked or broken. - T.V. valve, reverse boost valve or bushing stuck, damaged or incorrectly assembled. - Orifice hole in pressure regulator valve plugged. - Sticking slide or excessive rotor clearance. - Pressure relief ball not seated or damaged. - Porosity in pump cover or body. - Wrong pump cover. - Pump faces not flat. <ul style="list-style-type: none"> - Intake pipe restricted by casting flash. - Cracks in filter body or intake pipe. - "O" ring seal missing, cut or damaged. <ul style="list-style-type: none"> - Stuck or damaged. <ul style="list-style-type: none"> - Misassembled, binding or damaged. <ul style="list-style-type: none"> - Misassembled, binding or damaged. <ul style="list-style-type: none"> - Manual valve scored or damaged. - Spacer plate or gaskets incorrect, misassembled or damaged. - Face not flat. - Throttle valve sticking. - Throttle valve sleeve rotated in bore or retaining pin not seated. - T.V. limit valve sticking. - Modulated downshift valve stuck. - Line bias valve stuck. - 2-3 shift valve stuck. - Check balls omitted or misassembled. <ul style="list-style-type: none"> - Case to valve body face not flat.
HIGH OR LOW SHIFT POINTS	1. T.V. Cable 2. T.V. Exhaust Ball 3. Throttle Lever & Bracket Assy. 4. Oil Pump Assembly 5. Valve Body Assembly	<ul style="list-style-type: none"> - Binding or not correctly adjusted. <ul style="list-style-type: none"> - Stuck or damaged. <ul style="list-style-type: none"> - Misassembled, binding or damaged. <ul style="list-style-type: none"> - Stuck pressure regulator valve or T.V. boost valve. - Sticking pump slide. <ul style="list-style-type: none"> - Sticking throttle valve or plunger. - Modulated T.V. up or down valves sticking. - T.V. limit valve sticking. - Spacer plate or gaskets misassembled, damaged or incorrect.

DIAGNOSIS GUIDE 1

COMPLAINT	INSPECT	CAUSE
1ST GEAR RANGE ONLY – NO UPSHIFT	<p>1. Governor Assembly</p> <p>2. Valve Body</p> <p>3. Case</p> <p>4. 2-4 Servo Assembly</p> <p>5. 2-4 Band Assembly</p>	<ul style="list-style-type: none"> – Governor valve sticking. – Governor driven gear loose or damaged. – Governor driven gear retaining pin missing. – Nicks or burrs on output shaft. – Nicks or burrs on governor sleeve or case bore. – Governor support pin in case too long or short. – Governor weights or springs missing, binding or damaged. – 1-2 shift valve sticking. – Spacer plate or gaskets mispositioned or damaged. – Case to valve body face not flat or damaged. – Governor screen restricted or damaged. – Restricted or blocked apply passages in case. – Nicks or burrs on servo pin or pin bore in case. – Missing or damaged piston or pin seals. – 4th servo piston in backwards. – 2-4 band worn or damaged. – Band anchor pin not engaged.
SLIPS IN 1ST GEAR	<p>1. Forward Clutch Assembly</p> <p>2. Input Housing & Shaft Assy.</p> <p>3. Valve Body</p> <p>4. T.V. Cable</p>	<ul style="list-style-type: none"> – Clutch plates worn. – Porosity or damage in forward clutch piston. – Forward clutch piston inner and outer seals missing, cut or damaged. – Input housing to forward clutch housing “O” ring seal missing, cut or damaged. – Damaged forward clutch housing. – Forward clutch housing retainer and ball assembly not sealing or damaged. – Turbine shaft seals missing, cut or damaged. – Accumulator valve stuck. – Face not flat, damaged lands or interconnected passages. – Spacer plate or gaskets incorrect, mispositioned or damaged. – Binding or broken.

DIAGNOSIS GUIDE 2

COMPLAINT	INSPECT	CAUSE
SLIPS IN 1ST GEAR (Continued)	<p>1. 1-2 Accumulator Piston Assy.</p> <p>2. Oil Pressure</p> <p>3. 2-4 Servo Assembly</p>	<ul style="list-style-type: none"> - Porosity in piston or 1-2 accumulator cover and pin assembly. - Damaged ring grooves on piston. - Piston seal missing, cut or damaged. - 1-2 accumulator cover gasket missing or damaged. - Leak between piston and pin. - Broken 1-2 accumulator spring. - (See Causes of High or Low Oil Pressure.) - 4th servo piston in backwards.
1-2 SHIFT SPEED - HIGH OR LOW	<p>1. T.V. Cable</p> <p>2. Governor Assembly</p> <p>3. Throttle Lever & Bracket Assy.</p> <p>4. Valve Body</p> <p>5. Oil Pump Assembly or Case</p>	<ul style="list-style-type: none"> - Binding or broken. - Not correctly adjusted. - (See 1st Gear Range Only - No Upshift.) - Misassembled, binding or damaged. - T.V. link missing, binding or damaged. - T.V. exhaust check ball stuck. - T.V. plunger sticking. - Face not flat. - Face not flat.
SLIPPING OR ROUGH 1-2 SHIFT	<p>1. Throttle Lever & Bracket Assy.</p> <p>2. Valve Body Assembly</p> <p>3. 2-4 Servo Assembly</p> <p>4. 2nd Accumulator</p>	<ul style="list-style-type: none"> - Incorrectly installed or damaged. - T.V. cable broken or binding. - Throttle valve sticking. - T.V. bushing turned in its bore. - 1-2 shift valve train stuck. - Gaskets or spacer plate incorrect, mispositioned or damaged. - Line bias valve stuck. - Accumulator valve stuck. - T.V. limit valve stuck. - Face not flat. - Apply pin too long or too short. - Servo seals or "O" ring seals missing, cut or damaged. - Restricted or missing oil passages. - Servo bore in case damaged. - Porosity in 1-2 accumulator housing or piston. - Piston seal or groove damaged. - Nicks or burrs in 1-2 accumulator housing. - Missing or restricted oil passage.

DIAGNOSIS GUIDE 3

COMPLAINT	INSPECT	CAUSE
SLIPPING OR ROUGH 1-2 SHIFT (Continued)	<ol style="list-style-type: none"> 1. 2-4 Band 2. Oil Pump Assembly or Case 	<ul style="list-style-type: none"> - Worn or mispositioned. - Faces not flat.
NO 2-3 SHIFT OR 2-3 SHIFT SLIPPING, ROUGH OR HUNTING	<ol style="list-style-type: none"> 1. Converter 2. Governor Assembly 3. Oil Pump 4. Valve Body 5. Input Housing Assembly 6. Case 7. 2-4 Servo Assembly 	<ul style="list-style-type: none"> - Internal damage. - Valve stuck. - Drive gear retaining pin missing or loose. - Governor weights binding. - Governor drive gear damaged. - Governor support pin in case too long or too short. - Stator shaft sleeve scored or off location. - 2-3 valve train stuck. - Accumulator valve stuck. - Spacer plate or gaskets incorrect, mispositioned or damaged. - Throttle valve stuck. - T.V. limit valve stuck. - Clutch plates worn (3-4 or forward). - Excessive clutch plate travel. - Cut or damaged piston seals (3-4 or forward). - Porosity in 3-4 clutch housing or piston. - 3-4 piston check ball stuck, damaged or not sealing. - Restricted apply passages. - Forward clutch piston retainer and ball assembly not seating. - Sealing balls loose or missing. - 3rd accumulator retainer and ball assembly not seating. - 2nd apply piston seals missing, cut or damaged. - Servo pin seals missing, cut or damaged.
NO 3-4 SHIFT/SLIPPING OR ROUGH 3-4 SHIFT	<ol style="list-style-type: none"> 1. Governor 2. Oil Pump Assembly 	<ul style="list-style-type: none"> - Governor weights binding. - Governor valve stuck. - Governor drive gear retaining pin missing or loose. - Governor drive gear damaged. - Governor support pin in case too long or too short. - Faces not flat. - Pump cover retainer and ball assembly omitted or damaged.

DIAGNOSIS GUIDE 4

COMPLAINT	INSPECT	CAUSE
NO 3-4 SHIFT/SLIPPING OR ROUGH 3-4 SHIFT (Continued)	<p>1. Valve Body Assembly</p> <p>2. 2-4 Servo Assembly</p> <p>3. Case</p> <p>4. Input Housing Assembly</p> <p>5. 2-4 Band Assembly</p>	<ul style="list-style-type: none"> - Valves stuck. <li style="padding-left: 20px;">2-3 shift valve train. <li style="padding-left: 20px;">Accumulator valve. <li style="padding-left: 20px;">Throttle valve. <li style="padding-left: 20px;">T.V. limit valve. <li style="padding-left: 20px;">1-2 shift valve train. <li style="padding-left: 20px;">3-2 control valve. - Manual valve link bent or damaged. - Spacer plates or gaskets incorrect, mis-positioned or damaged. - Incorrect band apply pin. - Missing or damaged servo seals. - Porosity in pistons, cover or case. - Damaged piston seal grooves. - Plugged or missing orifice cup plug. - 3rd accumulator retainer and ball assembly leaking. - Porosity in 3-4 accumulator piston or bore. - 3-4 accumulator piston seal or seal grooves damaged. - Plugged or missing orifice cup plug. - Restricted oil passage. - Refer to Slipping 2-3 Shift. - Worn or misassembled.
NO REVERSE OR SLIPS IN REVERSE	<p>1. Input Housing Assembly</p> <p>2. Manual Linkage</p> <p>3. Oil Pump Assembly</p> <p>4. Valve Body Assembly</p>	<ul style="list-style-type: none"> - 3-4 apply ring stuck in applied position. - Forward clutch not releasing. - Turbine shaft seals missing, cut or damaged. - Not adjusted. - Retainer and Ball assembly missing or damaged. - Stator shaft seal rings or ring grooves damaged. - Stator shaft sleeve scored or damaged. - Reverse boost valve stuck, damaged or misassembled. - Cup plug missing. - Restricted oil passage. - Faces hot flat. - Converter clutch apply valve stuck. - 2-3 shift valve stuck. - Manual linkage not adjusted. - Spacer plate and gaskets incorrect, mis-positioned or damaged.

DIAGNOSIS GUIDE 5

COMPLAINT	INSPECT	CAUSE
NO OVERRUN BRAKING – MANUAL 3-2-1	<ol style="list-style-type: none"> 1. External Linkage 2. Valve Body Assembly 3. Input Clutch Assembly 	<ul style="list-style-type: none"> – Not adjusted properly. – Valves stuck. <ul style="list-style-type: none"> 4-3 sequence valve Throttle valve – Check ball #3 mispositioned. – Spacer plate and gaskets incorrect, damaged or mispositioned. – Turbine shaft oil passages plugged or not drilled. – Turbine shaft seal rings damaged. – Turbine shaft sealing balls loose or missing. – Porosity in forward or overrun clutch piston. – Overrun piston seals cut or damaged. – Overrun piston check ball not sealing.
NO CONVERTER CLUTCH APPLY	<ol style="list-style-type: none"> 1. Electrical 2. Converter 3. Oil Pump Assembly 4. Valve Body Assembly 5. Input Housing And Shaft 	<ul style="list-style-type: none"> – 12 volts not supplied to transmission. – Outside electrical connector damaged. – Inside electrical connector, wiring harness or solenoid damaged. – Electrical short (pinched solenoid wire). – Solenoid not grounded. – Incorrect or damaged pressure switches. – Internal damage. – Converter clutch apply valve stuck or assembled backwards. – Converter clutch apply valve retaining ring mispositioned. – Pump to case gasket mispositioned. – Orifice cup plug plugged. – Solenoid "O" ring seal cut or damaged. – Orifice cup plug omitted from cooler in passage. – High or uneven bolt torque (pump body to cover). – Valves stuck. <ul style="list-style-type: none"> Converter clutch shift valve Throttle valve – Turbine shaft "O" ring seal cut or damaged. – Turbine shaft retainer and ball assembly plugged.

DIAGNOSIS GUIDE 7

COMPLAINT	INSPECT	CAUSE
CONVERTER SHUDDER	<ol style="list-style-type: none"> 1. Torque Converter Assembly 2. Valve Body 3. Oil Pump Assembly 4. Oil Filter 5. Miscellaneous 6. Input Housing And Shaft Assy. 	<ul style="list-style-type: none"> - Internal damage. - Converter clutch shift valve stuck. - Converter clutch apply valve stuck. - Restricted oil passage. - Crack in filter body. - Flash restricting filter neck. - "O" ring seal cut or damaged. - Low oil pressure. - Engine not tuned properly. - Turbine shaft "O" ring cut or damaged. - Turbine shaft retainer and ball assembly damaged.
NO CONVERTER CLUTCH RELEASE	<ol style="list-style-type: none"> 1. Solenoid 2. Converter 3. Oil Pump Assembly 	<ul style="list-style-type: none"> - External ground. - Internal damage. - Converter clutch apply valve stuck.
DRIVES IN NEUTRAL	<ol style="list-style-type: none"> 1. Forward Clutch 2. Manual Linkage 3. Case 	<ul style="list-style-type: none"> - Not releasing. - Incorrectly adjusted. - Disconnected. - Face not flat. - Internal leakage.
2ND GEAR START (DRIVE RANGE)	<ol style="list-style-type: none"> 1. Governor Assembly 2. Forward Sprag Clutch 	<ul style="list-style-type: none"> - Valve stuck. - Governor support pin too long or missing. - Sprag assembly installed backwards.

DIAGNOSIS GUIDE 8

COMPLAINT	INSPECT	CAUSE
NO PARK	1. Parking Linkage	<ul style="list-style-type: none"> - Actuator rod assembly bent or damaged. - Actuator rod spring binding or improperly crimped. - Actuator rod not attached to inside detent lever. - Parking bracket damaged or not torqued properly. - Inside detent lever not torqued properly. - Detent roller mispositioned or not torqued properly. - Parking pawl binding or damaged.
RACHETING NOISE	1. Parking Pawl	<ul style="list-style-type: none"> - Parking pawl return spring weak, damaged or misassembled.
OIL OUT THE VENT	1. Oil Pump 2. Valve Body	<ul style="list-style-type: none"> - Chamfer in pump body rotor pocket too large. - T.V. limit valve stuck.
VIBRATION IN REVERSE AND WHINING NOISE IN PARK	1. Oil Pump	<ul style="list-style-type: none"> - Broken vane rings.

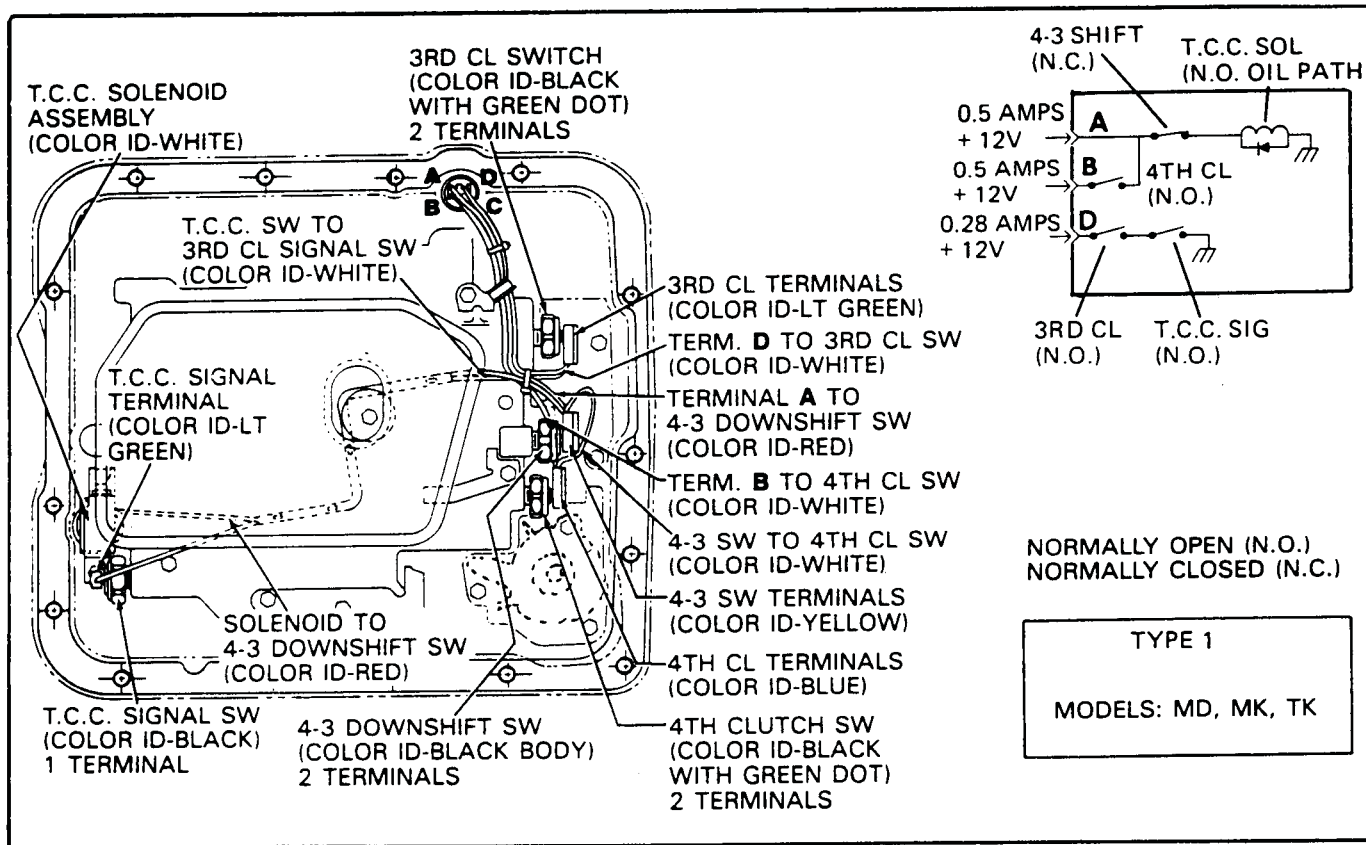

FIGURE 6 Type 1 Wiring Diagram

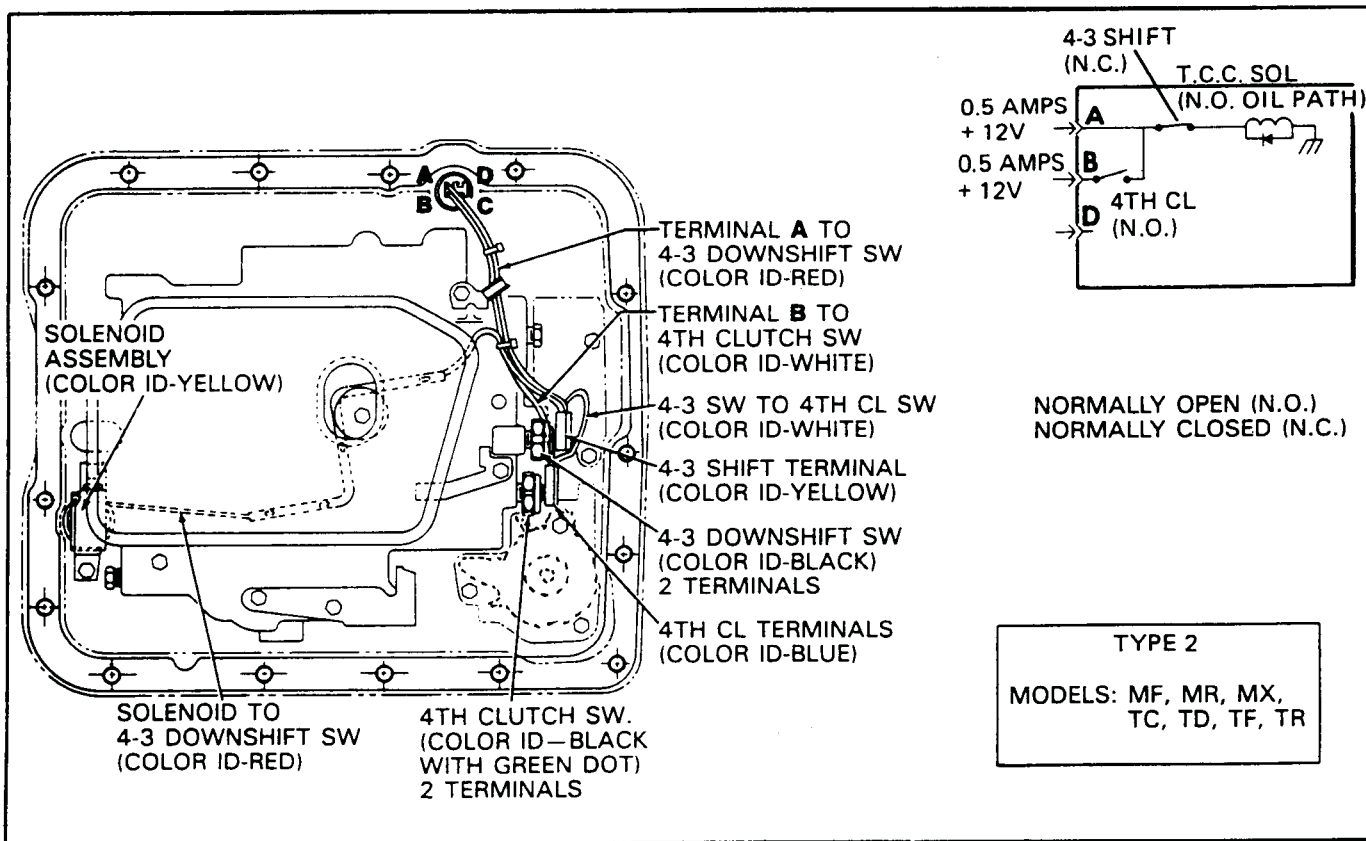

FIGURE 7 Type 2 Wiring Diagram

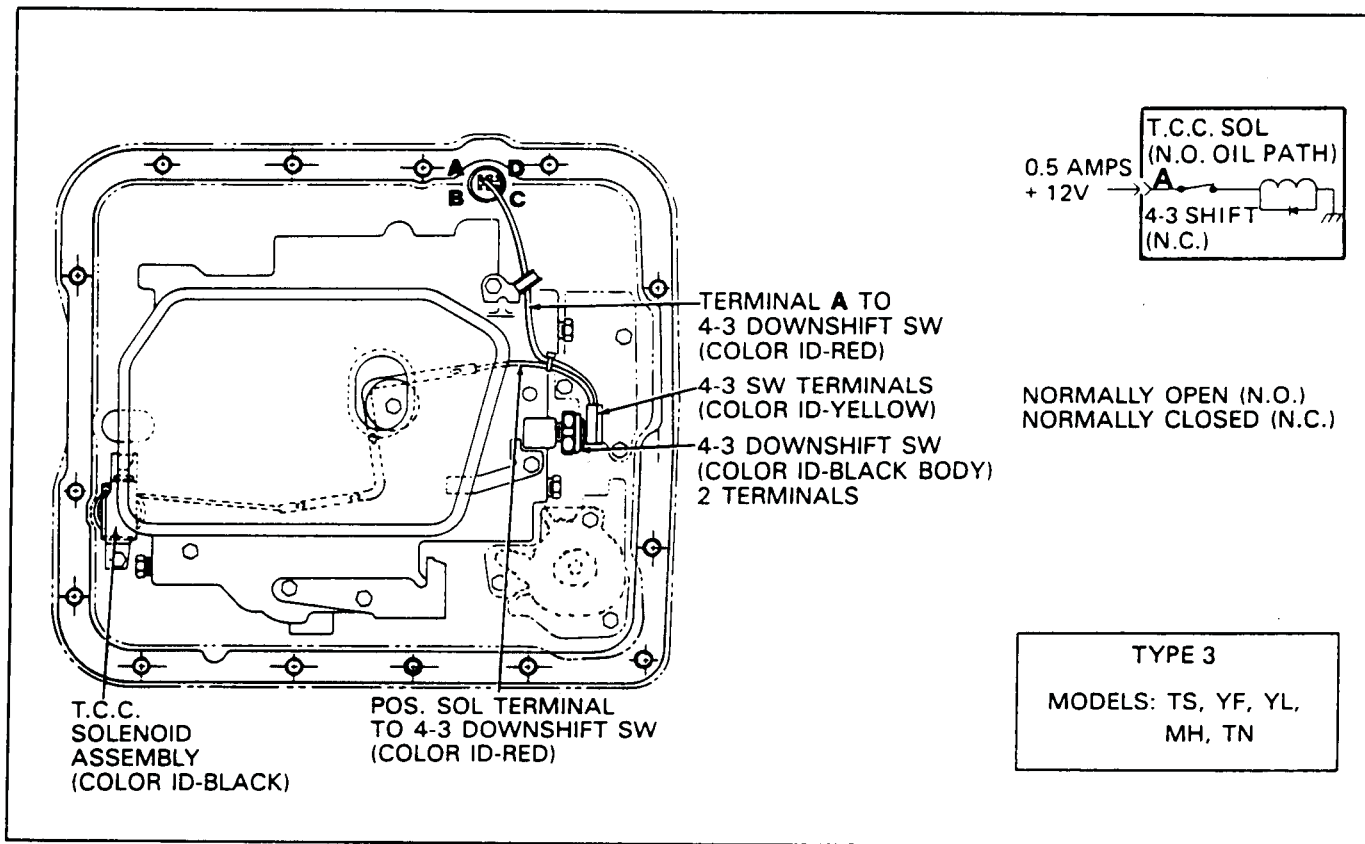

FIGURE 8 Type 3 Wiring Diagram

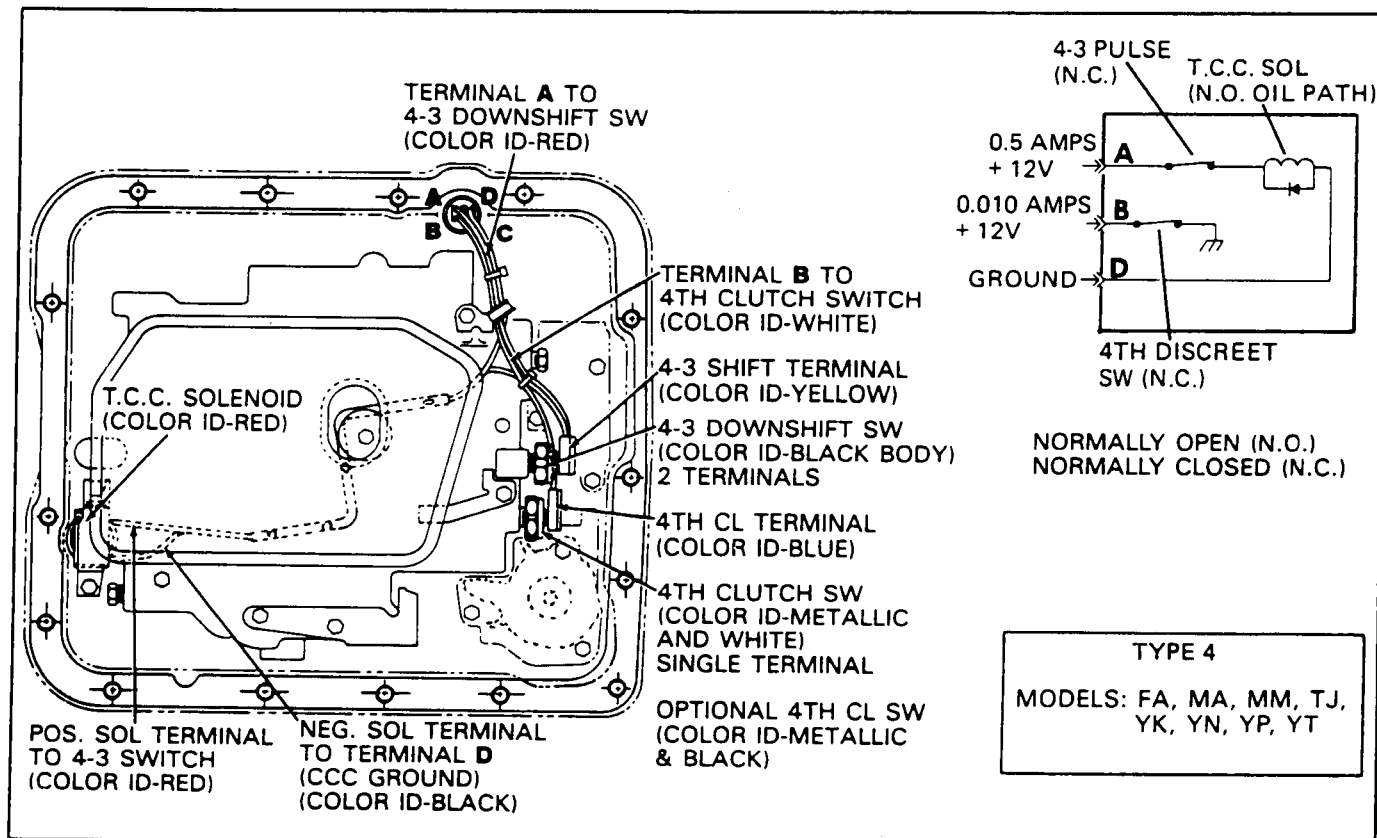

FIGURE 9 Type 4 Wiring Diagram

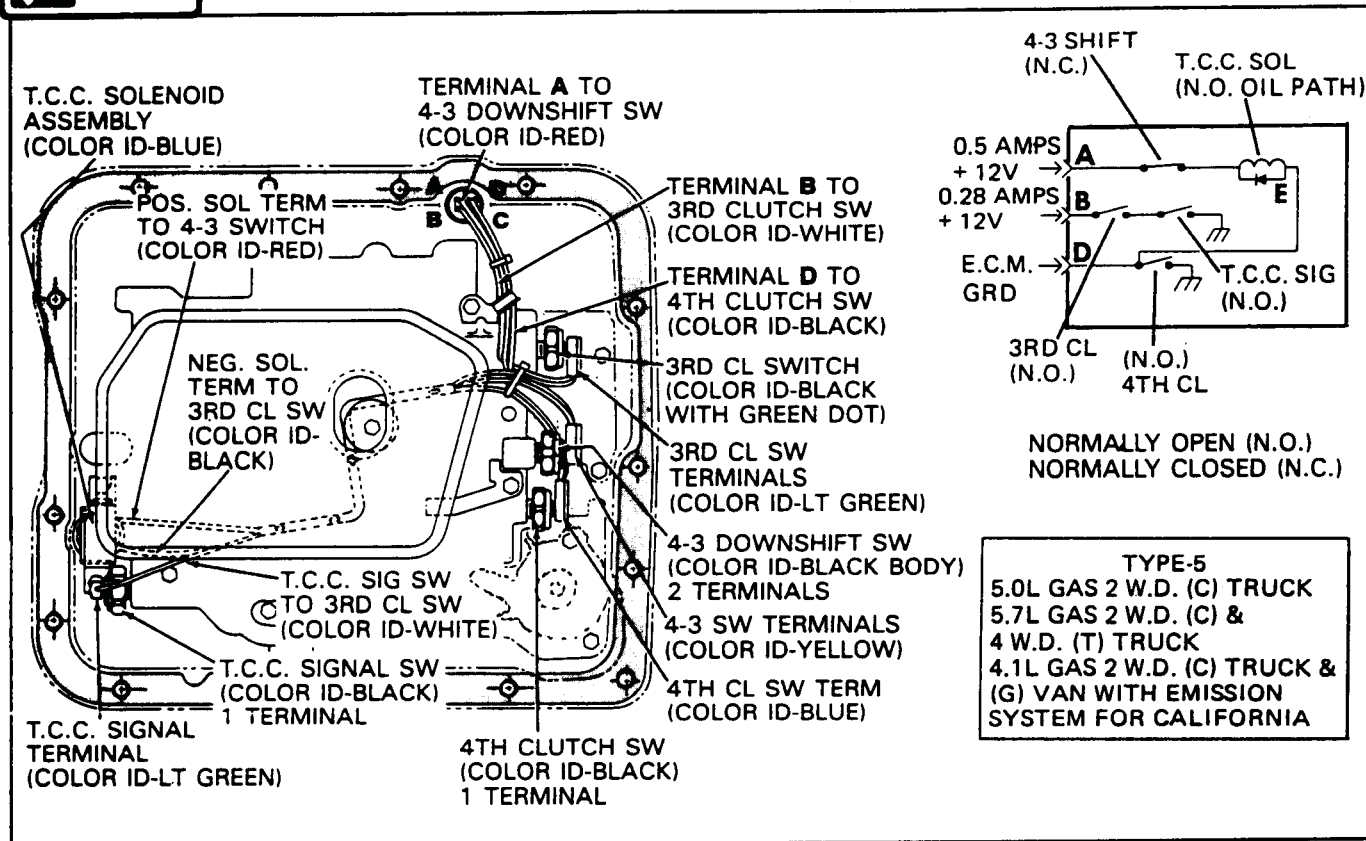

FIGURE 10 Type 5 Wiring Diagram

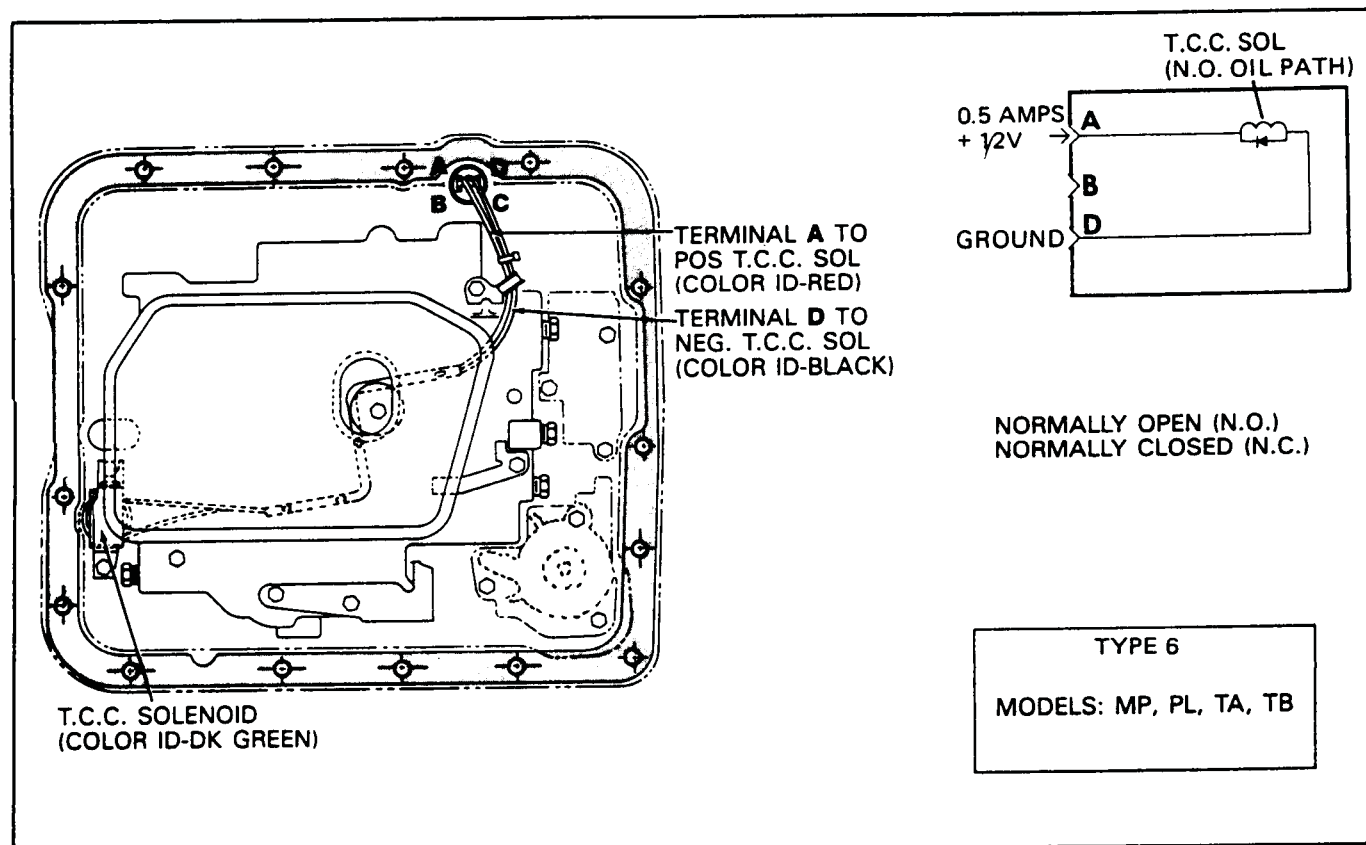

FIGURE 11 Type 6 Wiring Diagram

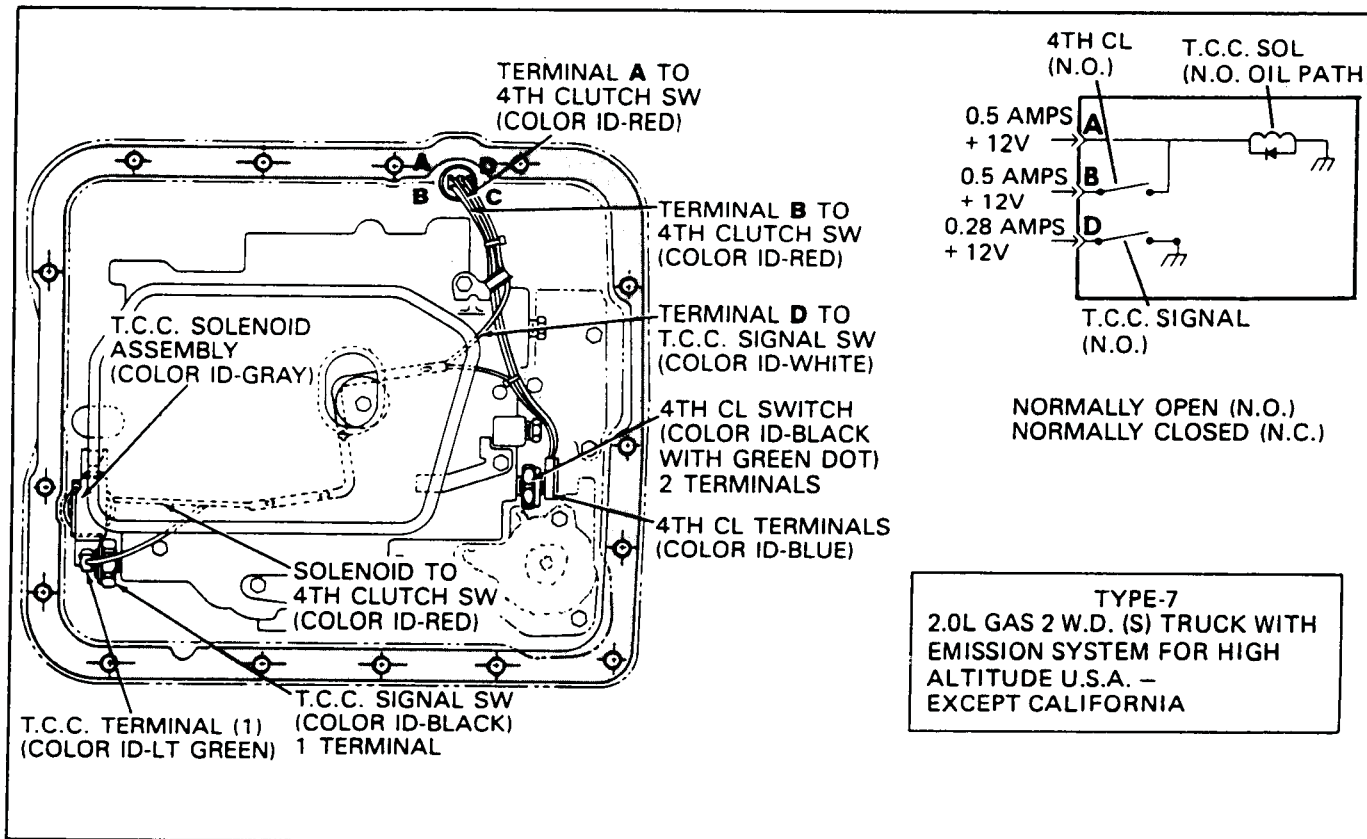

FIGURE 12 Type 7 Wiring Diagram

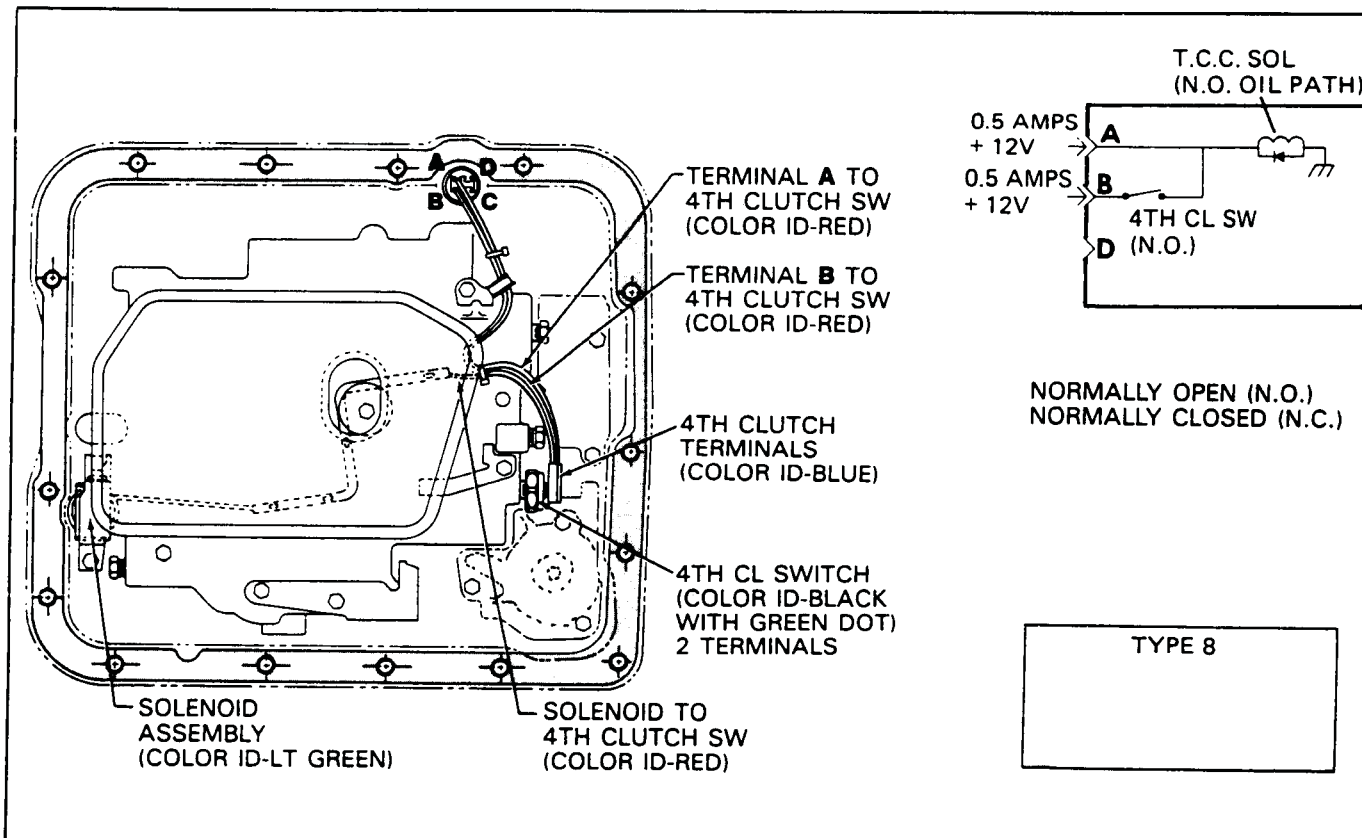

FIGURE 13 Type 8 Wiring Diagram

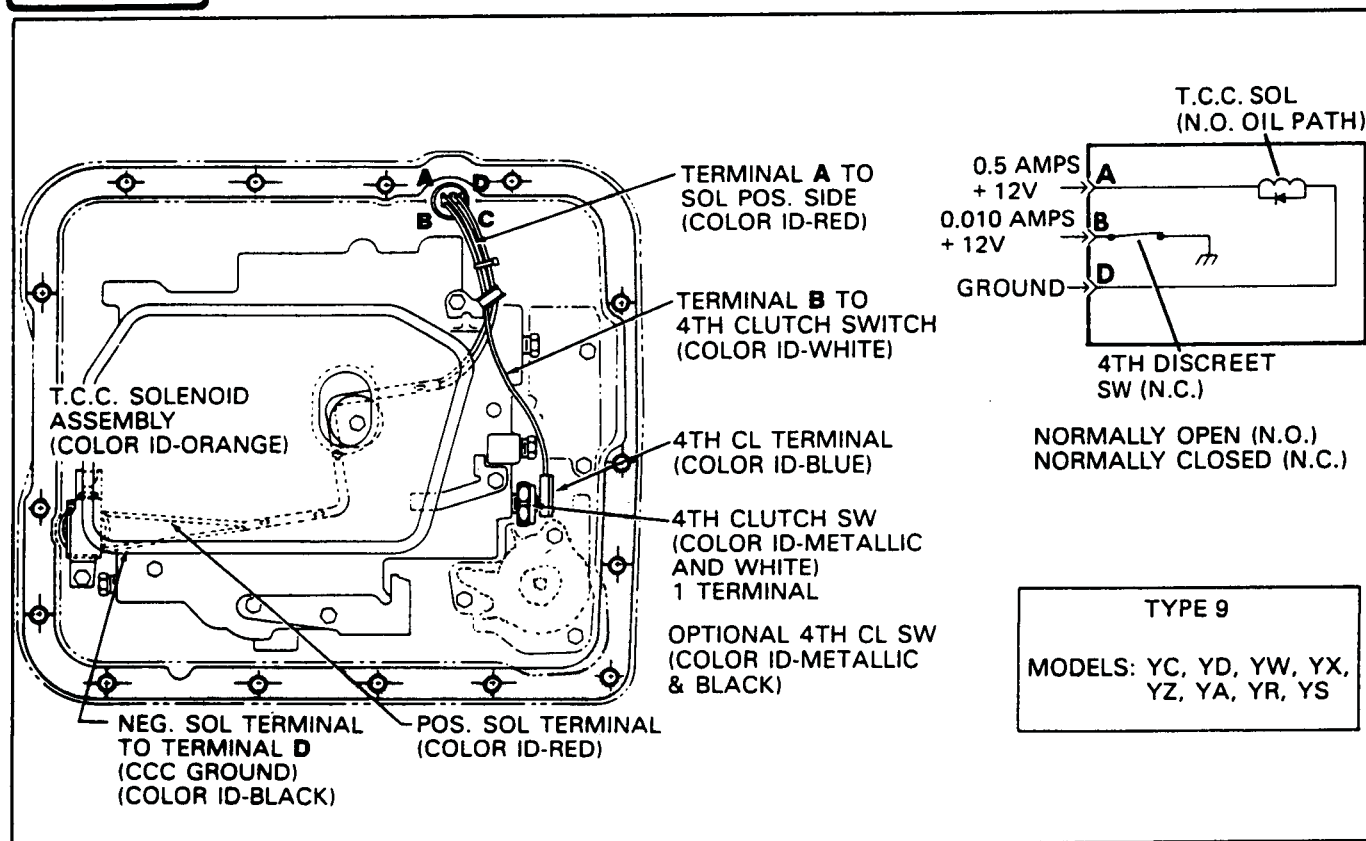

FIGURE 14 Type 9 Wiring Diagram

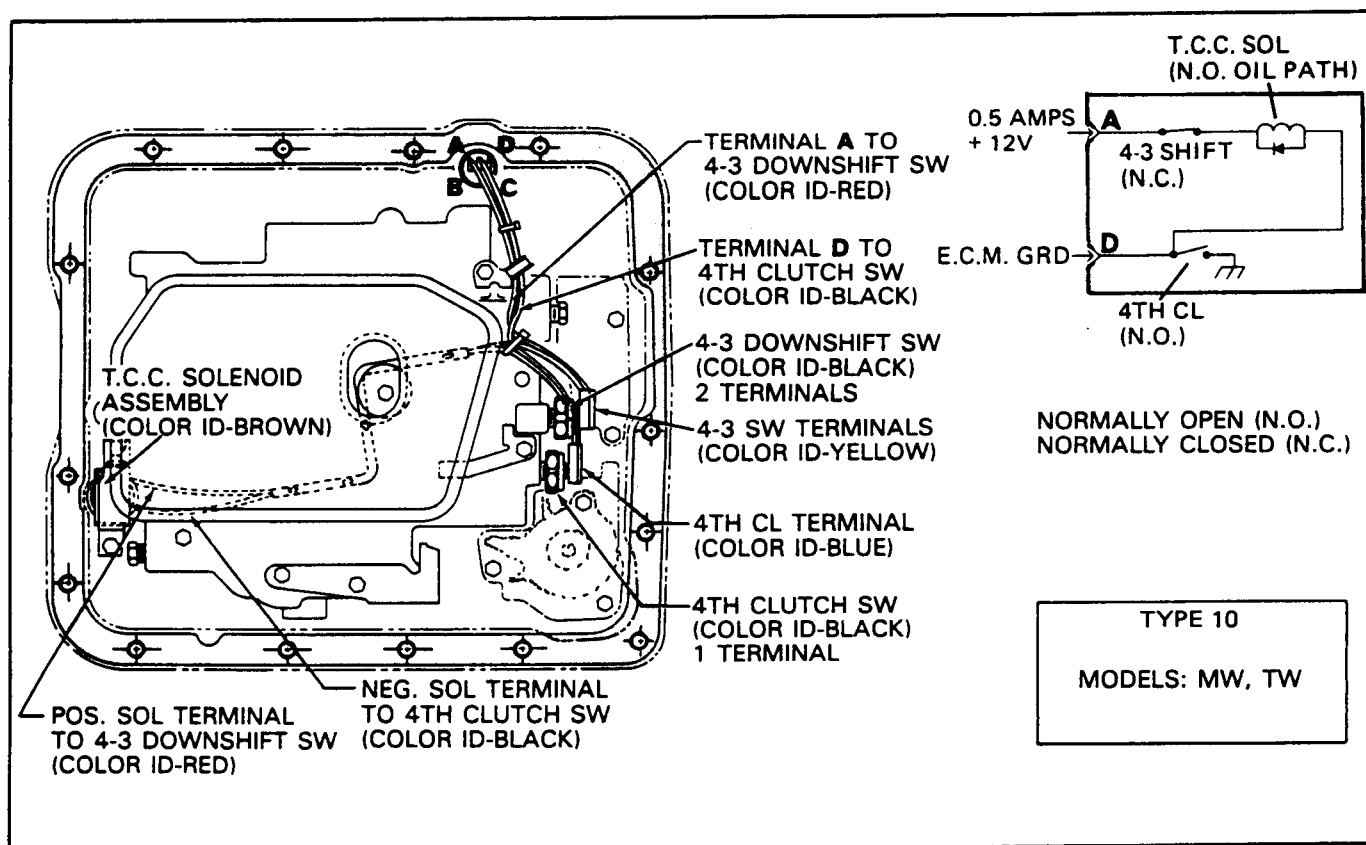

FIGURE 15 Type 10 Wiring Diagram



THM 700-R4 SOLENOID IDENTIFICATION

THM 700-R4 solenoids can be identified by wiring type, two different ways, when separated from the transmission and is done in the following manner:

1. Color of the insulator (See Figure 6)
2. Last four digits of the OEM part number will be cast into the top of the insulator (See Figure 6).

The part numbers we have given you are late part numbers. If the number on your solenoid differs from the one in the chart, use the color of the insulator to identify the solenoid.

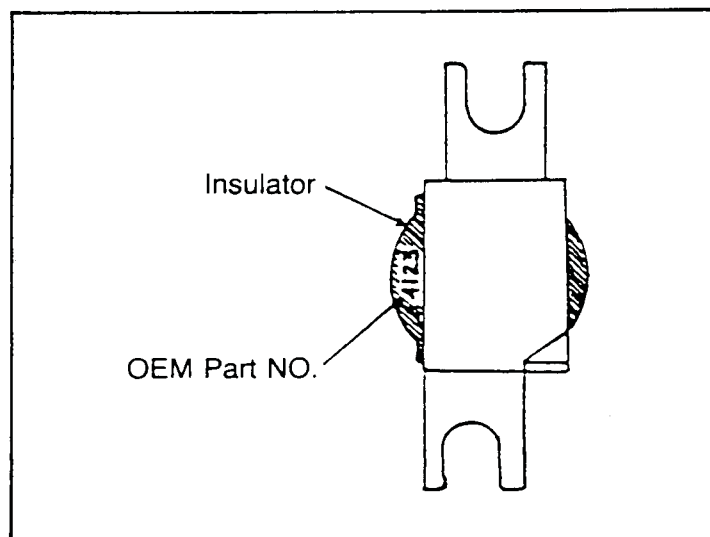

Type	Part Number	Color ID
1	8654121	White
2	8654122	Yellow
3	8654123	Black
4	8654124	Red
5	8654125	Blue
6	8654126	Dk. Green
7	8654127	Gray
8	8654128	Lt. Green
9	8654129	Orange
10	8654130	Brown
14	8654194	Pink
15	8654415	Dk. Blue

FIGURE 18

AUTOMATIC TRANSMISSION SERVICE GROUP

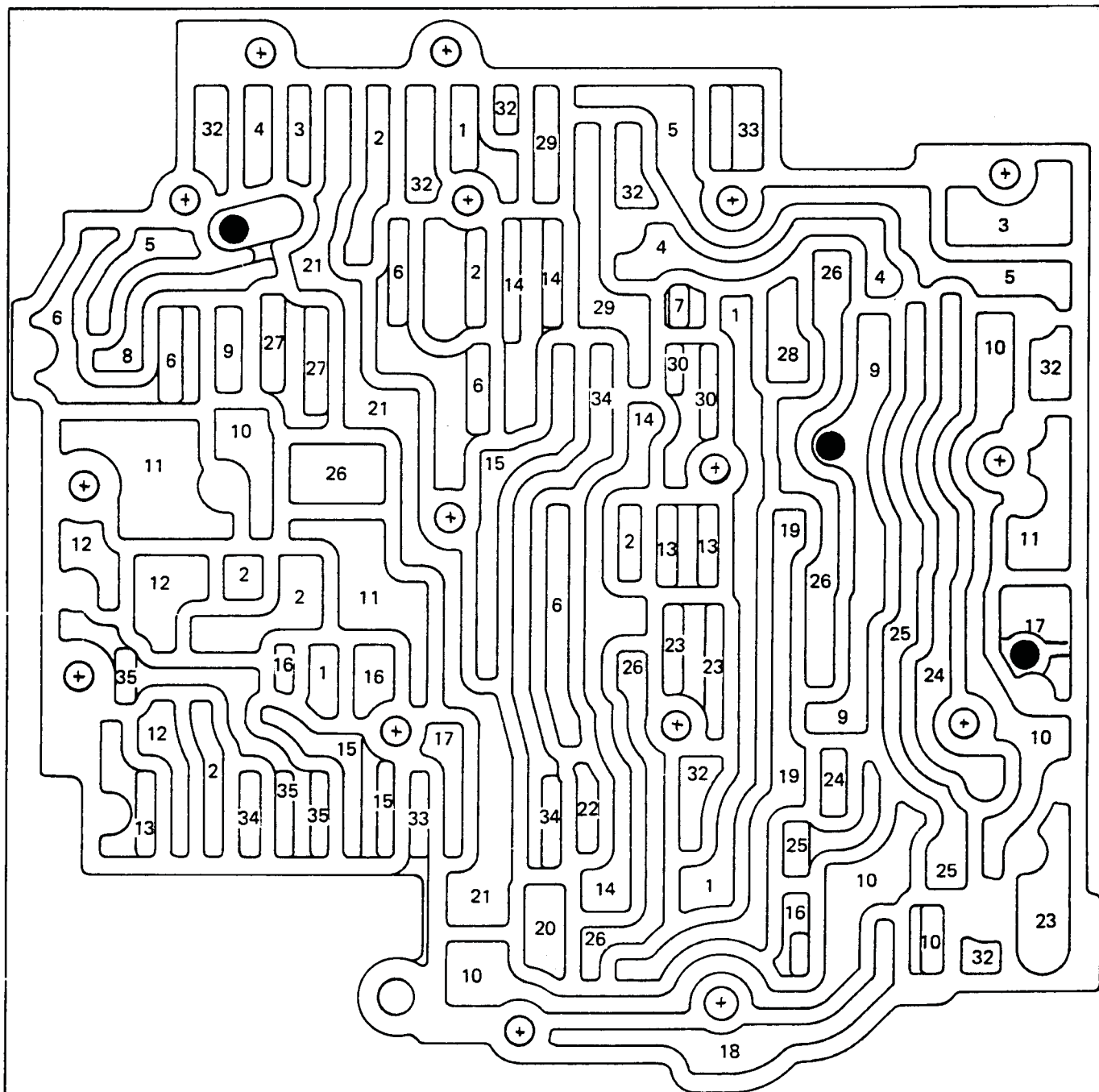

NO.	DESCRIPTION	NO.	DESCRIPTION	NO.	DESCRIPTION
1	LINE	13	4TH SIGNAL	25	MOD. DOWN
2	D4	14	2ND CLUTCH	26	DETENT
3	D2	15	3-4 ACCUMULATOR	27	3-4 CLUTCH
4	LO	16	T.V.F.	28	DETENT/LO
5	REVERSE	17	OVERRUN CLUTCH	29	RND4-3
6	GOVERNOR	18	T.V. EX.	30	3RD CLUTCH
7	LO - 1	19	D3/PART THROTTLE	31	IDENTIFICATION
8	LO/REVERSE	20	PART THROTTLE	32	VOID
9	3RD ACCUMULATOR	21	D3	33	EXHAUST
10	T.V.	22	4TH CLUTCH	34	SF
11	M.T.V.	23	C.C. SIG.	35	4-3
12	ACCUMULATOR	24	MOD. UP		

FIGURE 19

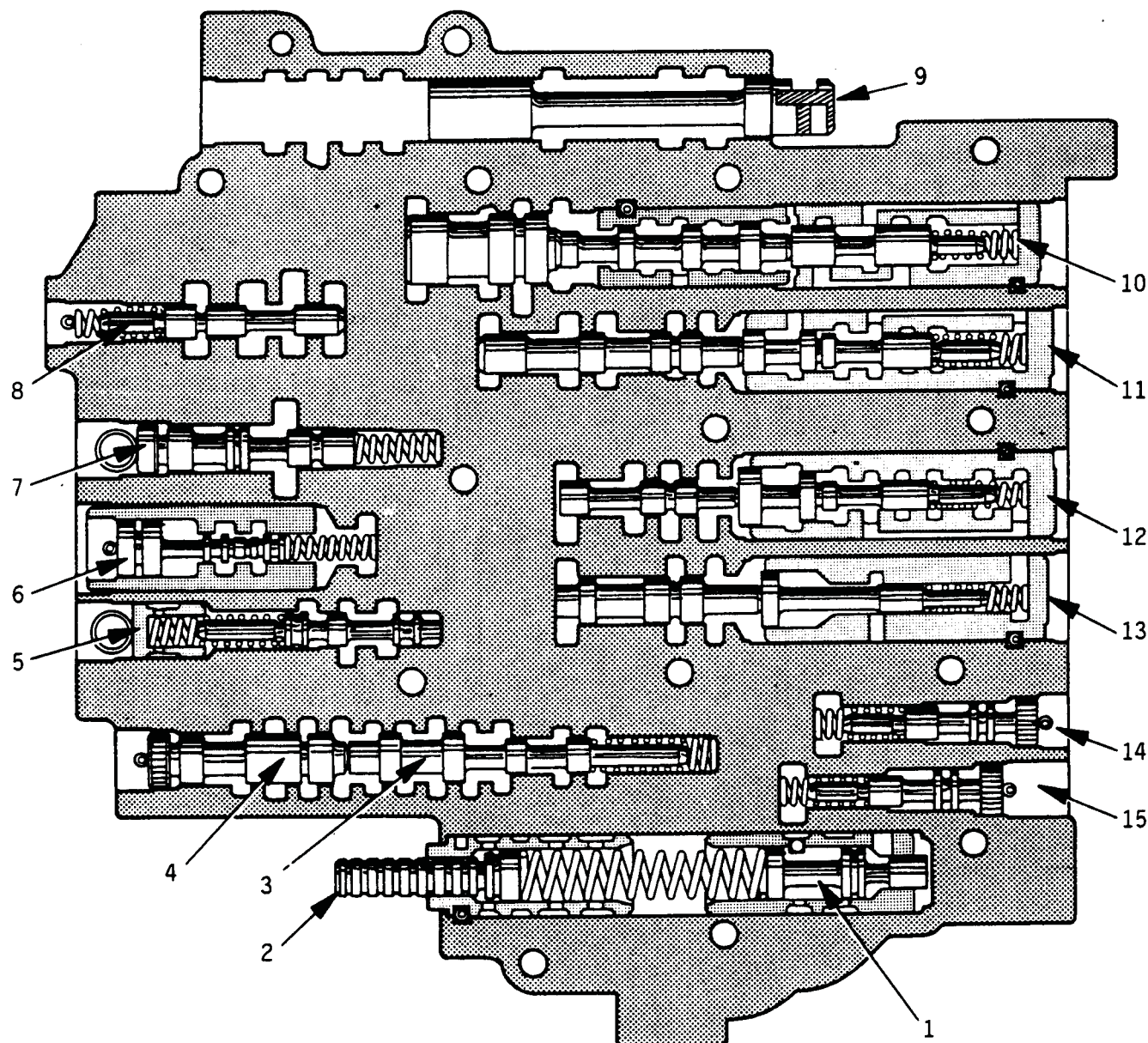

ALUMINUM BUSHING PLUGS MAY BE FOUND IN BORE NUMBER 13 ON SOME ECM MODELS.

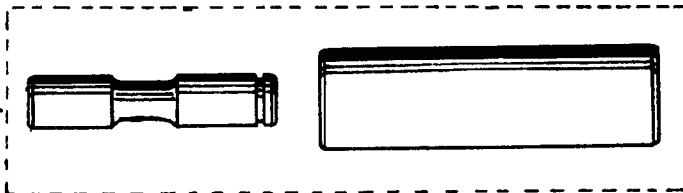

- 1 THROTTLE VALVE & BUSHING
- 2 T.V. PLUNGER & BUSHING
- 3 4-3 SEQUENCE VALVE
- 4 3-4 RELAY VALVE
- 5 T.V. LIMIT VALVE TRAIN
- 6 ACCUMULATOR VALVE TRAIN
- 7 LINE BIAS VALVE TRAIN
- 8 3-2 CONTROL VALVE TRAIN

- 9 MANUAL VALVE
- 10 1-2 SHIFT VALVE TRAIN
- 11 2-3 SHIFT VALVE TRAIN
- 12 3-4 SHIFT VALVE TRAIN
- 13 CONVERTER CLUTCH SHIFT VALVE TRAIN
- 14 M.T.V. UP VALVE TRAIN
- 15 M.T.V. DOWN VALVE TRAIN

FIGURE 20

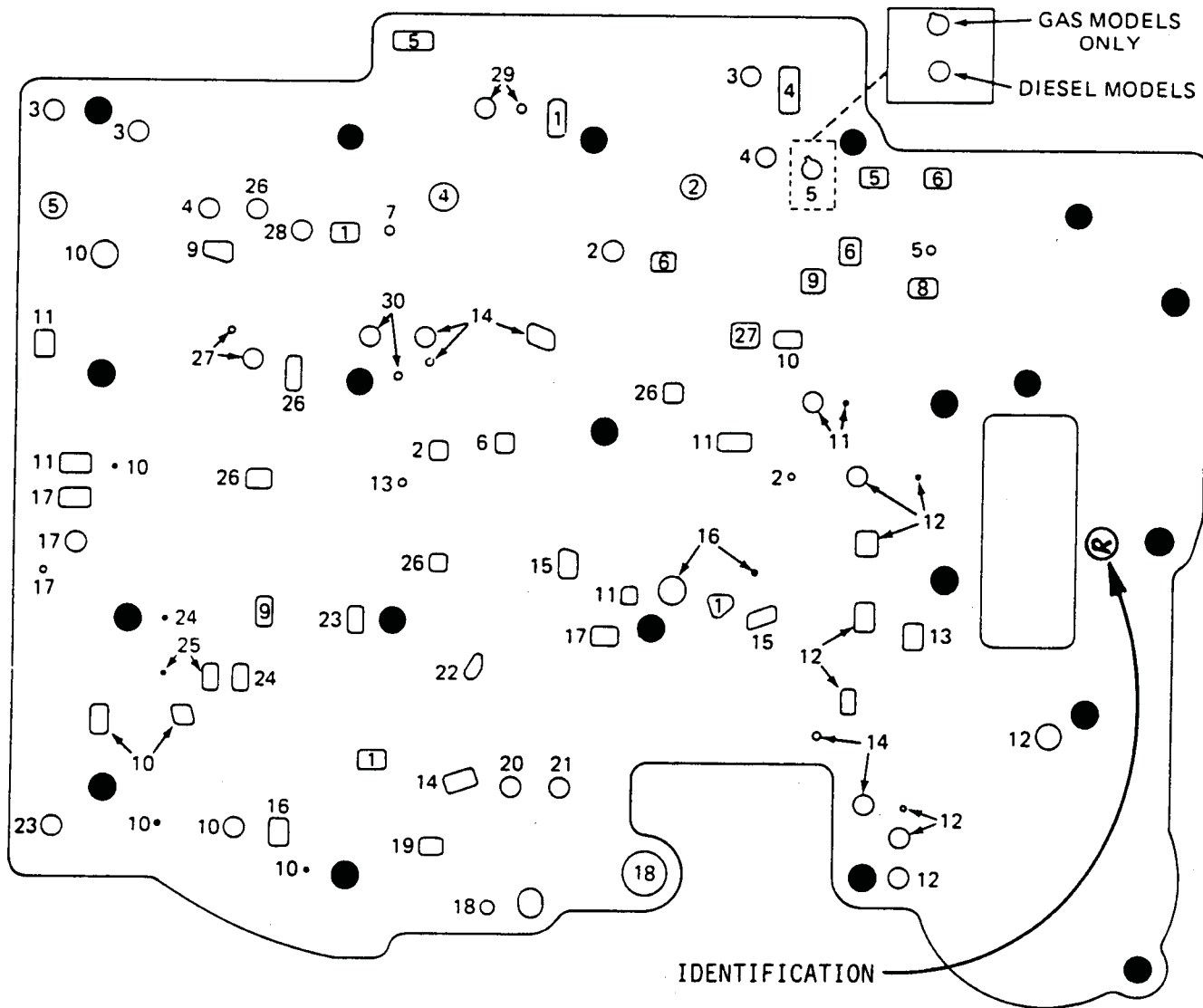

TYPICAL SPACER PLATE

- | | | |
|-------------------|---------------------|------------------|
| 1 LINE | 11 M.T.V. | 21 D3 |
| 2 D4 | 12 ACCUMULATOR | 22 4TH OIL |
| 3 D2 | 13 4TH SIGNAL | 23 T.C.C. SIGNAL |
| 4 LOW | 14 2ND CLUTCH | 24 TV MOD. UP |
| 5 REVERSE | 15 3-4 ACCUMULATOR | 25 TV MOD. DOWN |
| 6 GOVERNOR | 16 T.V. FEED | 26 DETENT |
| 7 LO-1ST | 17 OVERRUN CLUTCH | 27 3-4 CLUTCH |
| 8 LOW/REVERSE | 18 T.V. EXHAUST | 28 DETENT/LOW |
| 9 3RD ACCUMULATOR | 19 D3/PART THROTTLE | 29 RND43 |
| 10 T.V. OIL | 20 PART THROTTLE | 30 3RD CLUTCH |

FIGURE 21

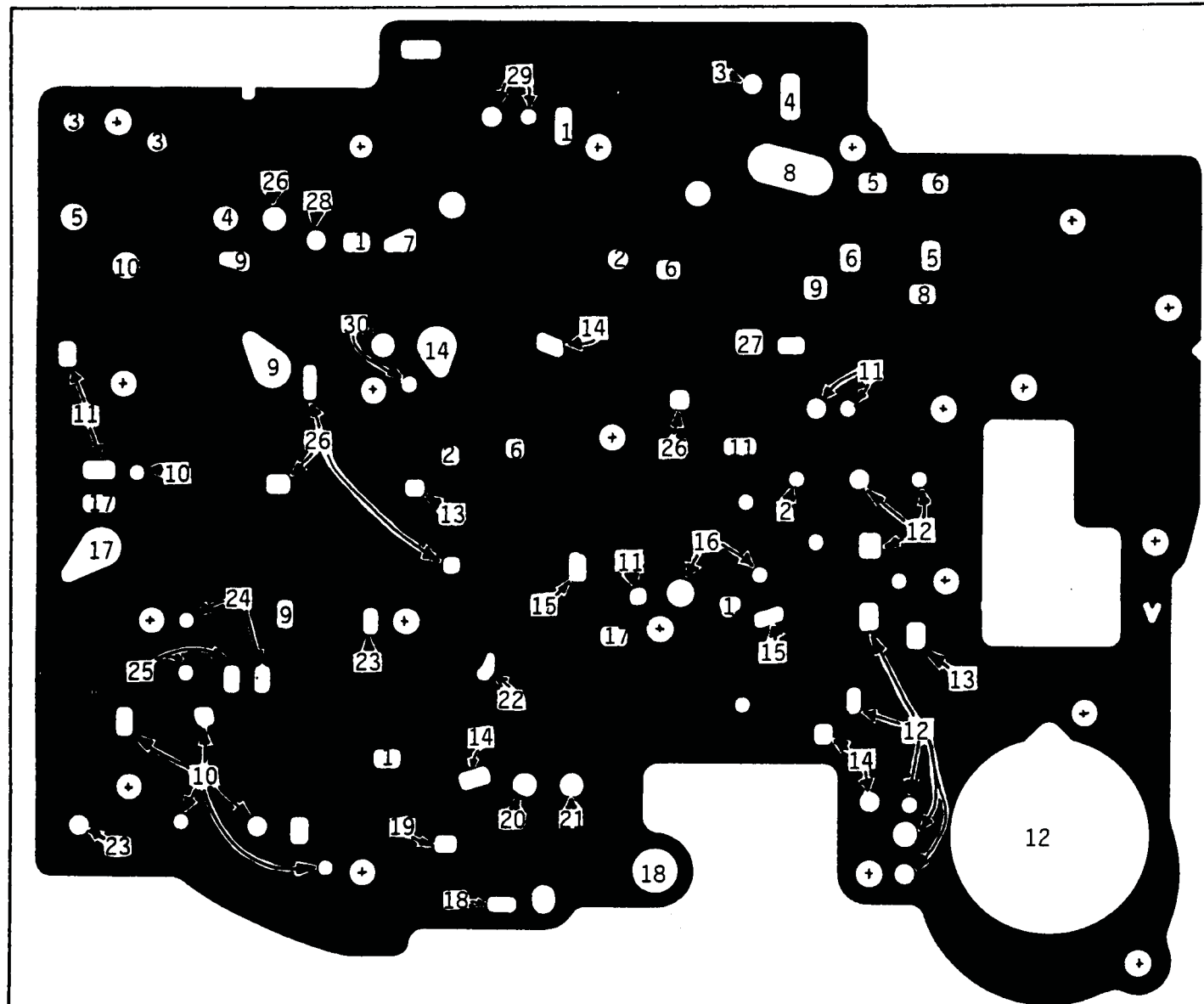

SPACER PLATE TO VALVE BODY GASKET

- | | | |
|-------------------|---------------------|------------------|
| 1 LINE | 11 M.T.V. | 21 D3 |
| 2 D4 | 12 ACCUMULATOR | 22 4TH OIL |
| 3 D2 | 13 4TH SIGNAL | 23 T.C.C. SIGNAL |
| 4 LOW | 14 2ND OIL | 24 TV MOD. UP |
| 5 REVERSE | 15 3-4 ACCUMULATOR | 25 TV MOD. DOWN |
| 6 GOVERNOR | 16 T.V. FEED | 26 DETENT |
| 7 LOW-1ST | 17 OVERRUN CLUTCH | 27 3-4 CLUTCH |
| 8 LOW/REVERSE | 18 T.V. EXHAUST | 28 DETENT/LOW |
| 9 3RD ACCUMULATOR | 19 D3/PART THROTTLE | 29 RND43 |
| 10 T.V. OIL | 20 PART THROTTLE | 30 3RD CLUTCH |

FIGURE 22

AUTOMATIC TRANSMISSION SERVICE GROUP

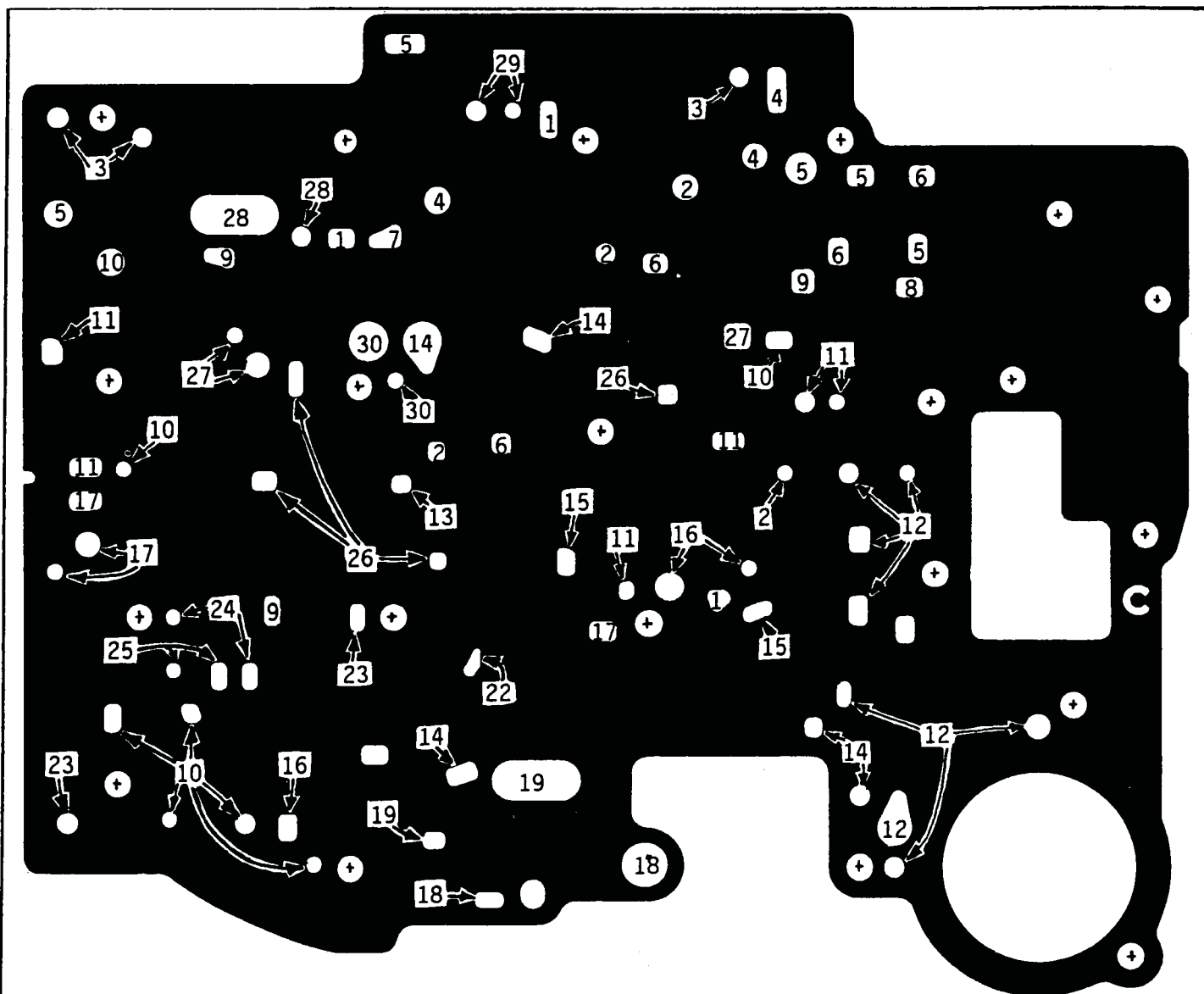

SPACER PLATE TO CASE GASKET

1 LINE	11 M.T.V.	21 D3
2 D4	12 ACCUMULATOR	22 4TH OIL
3 D2	13 4TH SIGNAL	23 T.C.C. SIGNAL
4 LOW	14 2ND OIL	24 TV MOD. UP
5 REVERSE	15 3-4 ACCUMULATOR	25 TV MOD. DOWN
6 GOVERNOR	16 T.V. FEED	26 DETENT
7 LOW-1ST	17 OVERRUN CLUTCH	27 3-4 CLUTCH
8 LOW/REVERSE	18 T.V. EXHAUST	28 DETENT/LOW
9 3RD ACCUMULATOR	19 D3/PART THROTTLE	29 RND43
10 T.V. OIL	20 PART THROTTLE	30 3RD CLUTCH

FIGURE 23

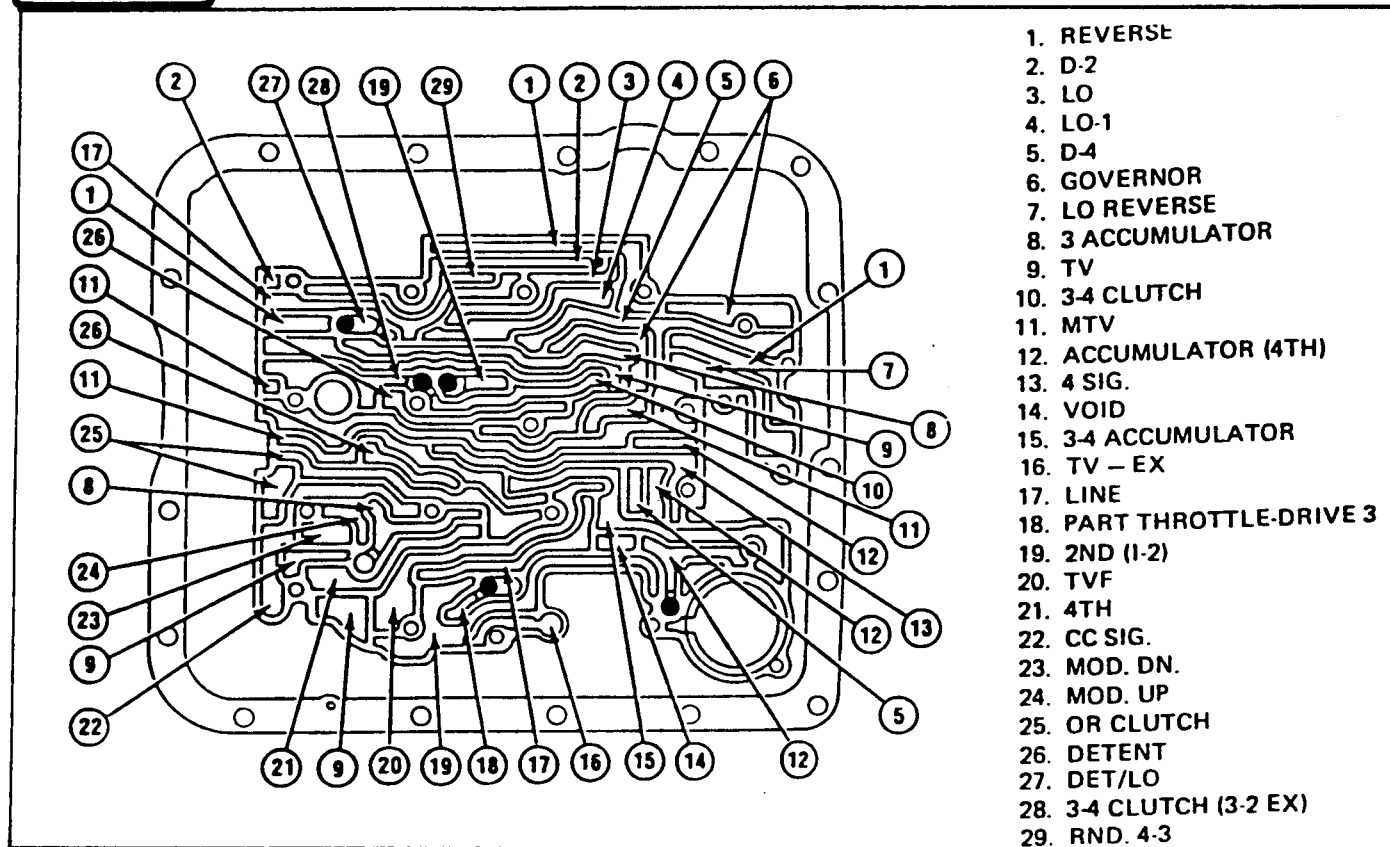

FIGURE 24

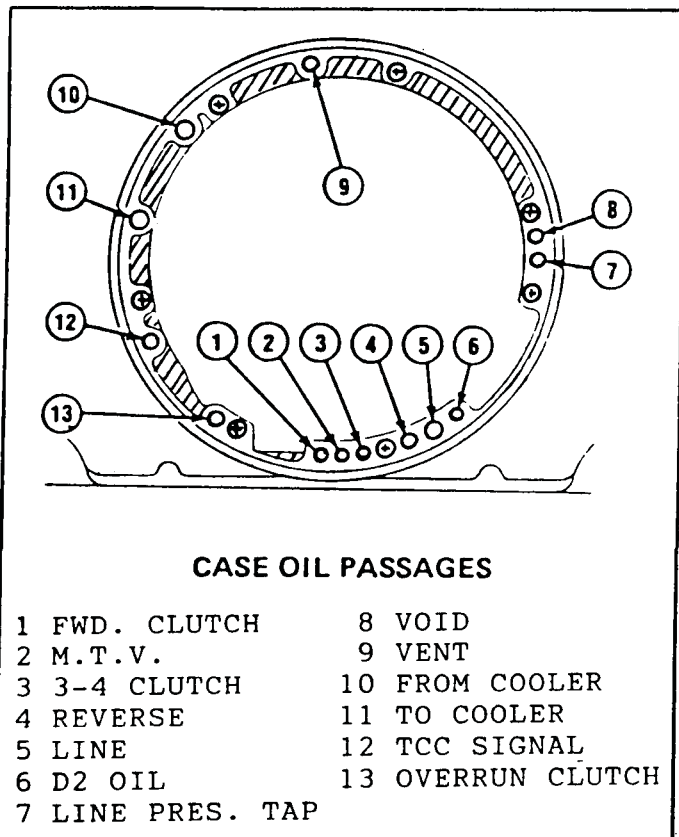

FIGURE 25

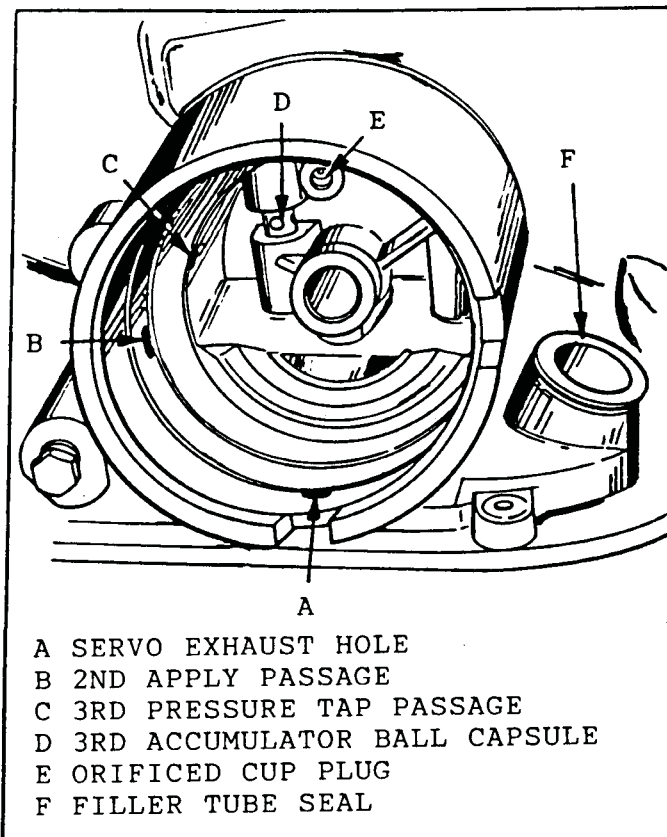

FIGURE 26

AUTOMATIC TRANSMISSION SERVICE GROUP

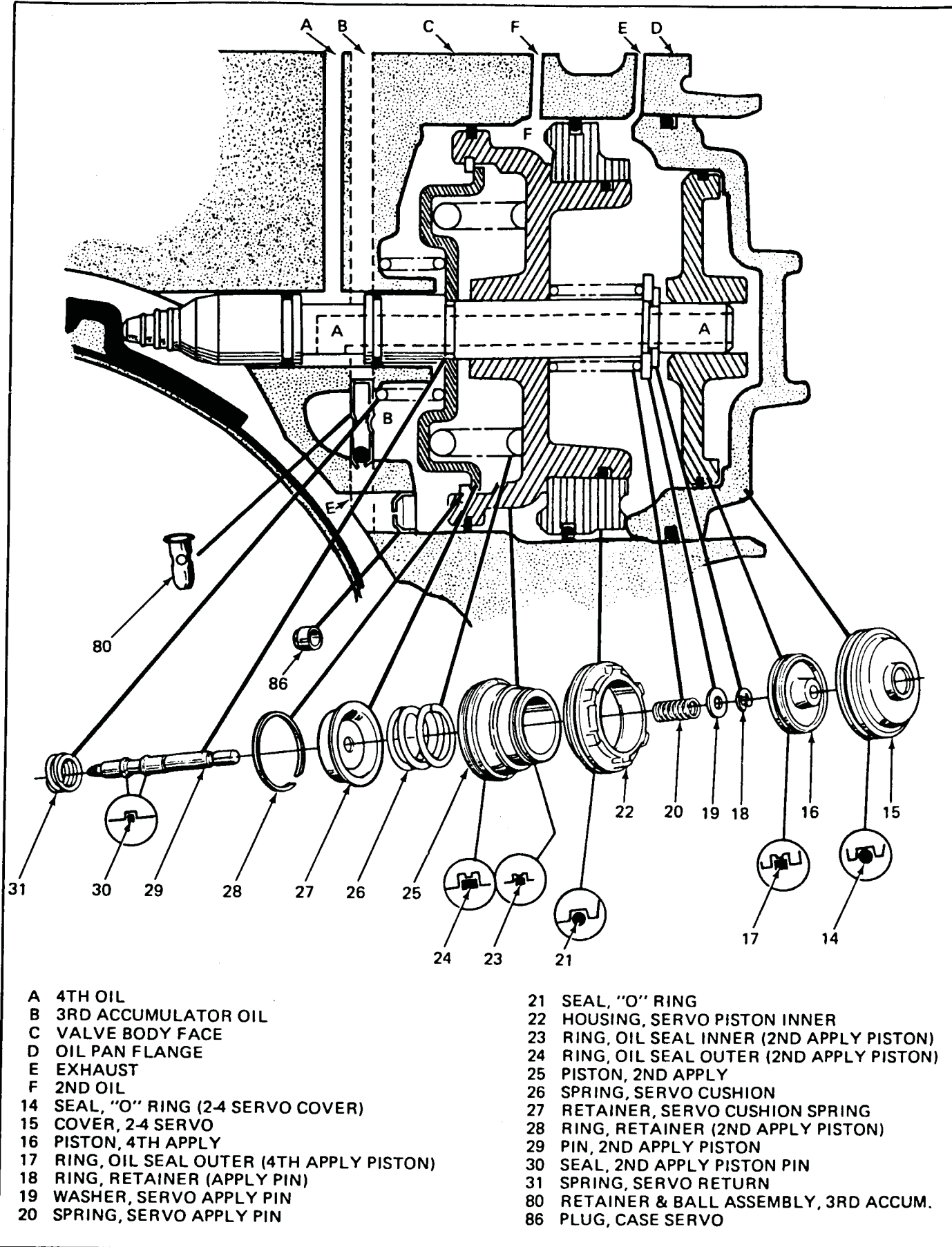

FIGURE 27

PUMP COVER OIL PASSAGES

- 1 VENT
- 2 LINE
- 3 DECREASE
- 4 EXHAUST
- 5 REV-INPUT CLUTCH
- 6 D2
- 7 M.T.V.
- 8 3-4 CLUTCH
- 9 OVERRUN CLUTCH
- 10 SEAL DRAIN
- 11 VOID
- 12 TCC SIGNAL
- 13 TO COOLER
- 14 TCC RELEASE OIL
- 15 LUBE
- 16 CONVERTER FEED

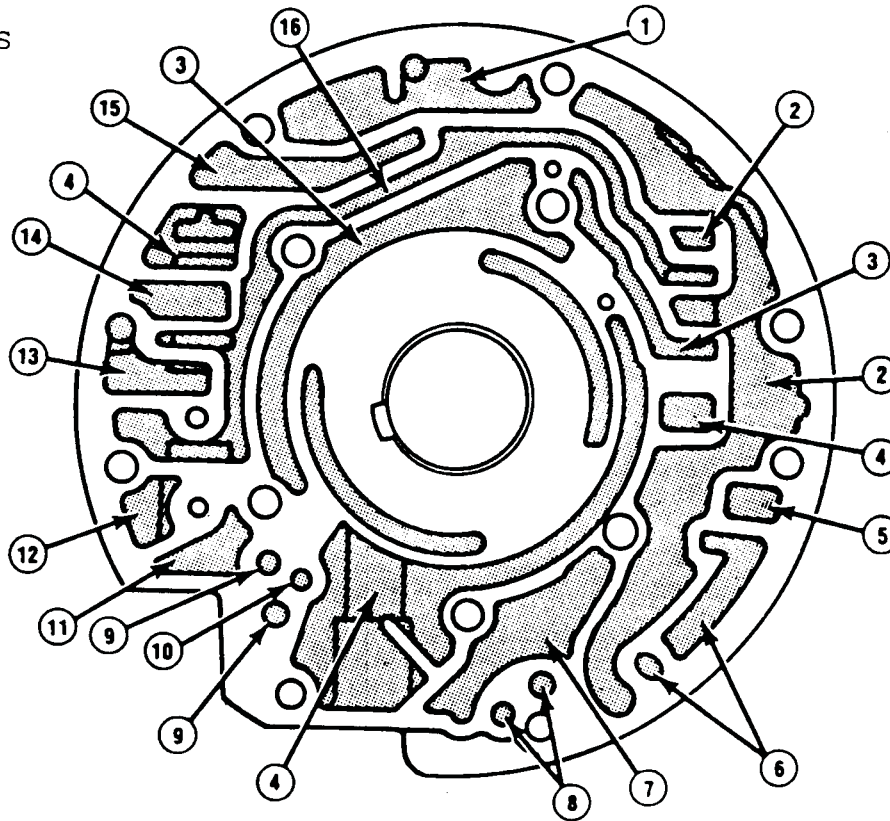

Figure 28

PUMP BODY OIL PASSAGES

- 1 CONVERTER FEED
- 2 VENT
- 3 LUBE
- 4 EXHAUST
- 5 TCC RELEASE OIL
- 6 TO COOLER
- 7 TCC SIGNAL
- 8 VOID
- 9 SEAL DRAIN
- 10 OVERRUN CLUTCH
- 11 3-4 CLUTCH
- 12 M.T.V.
- 13 D2
- 14 REV-INPUT CLUTCH
- 15 LINE
- 16 DECREASE

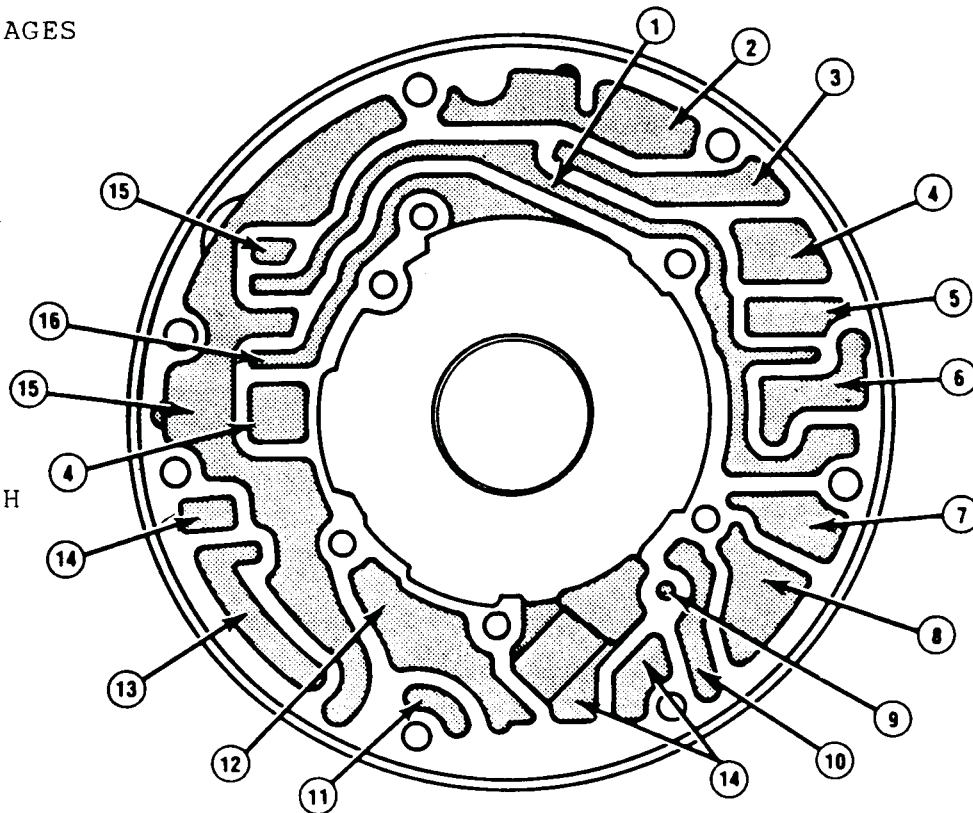

Figure 29

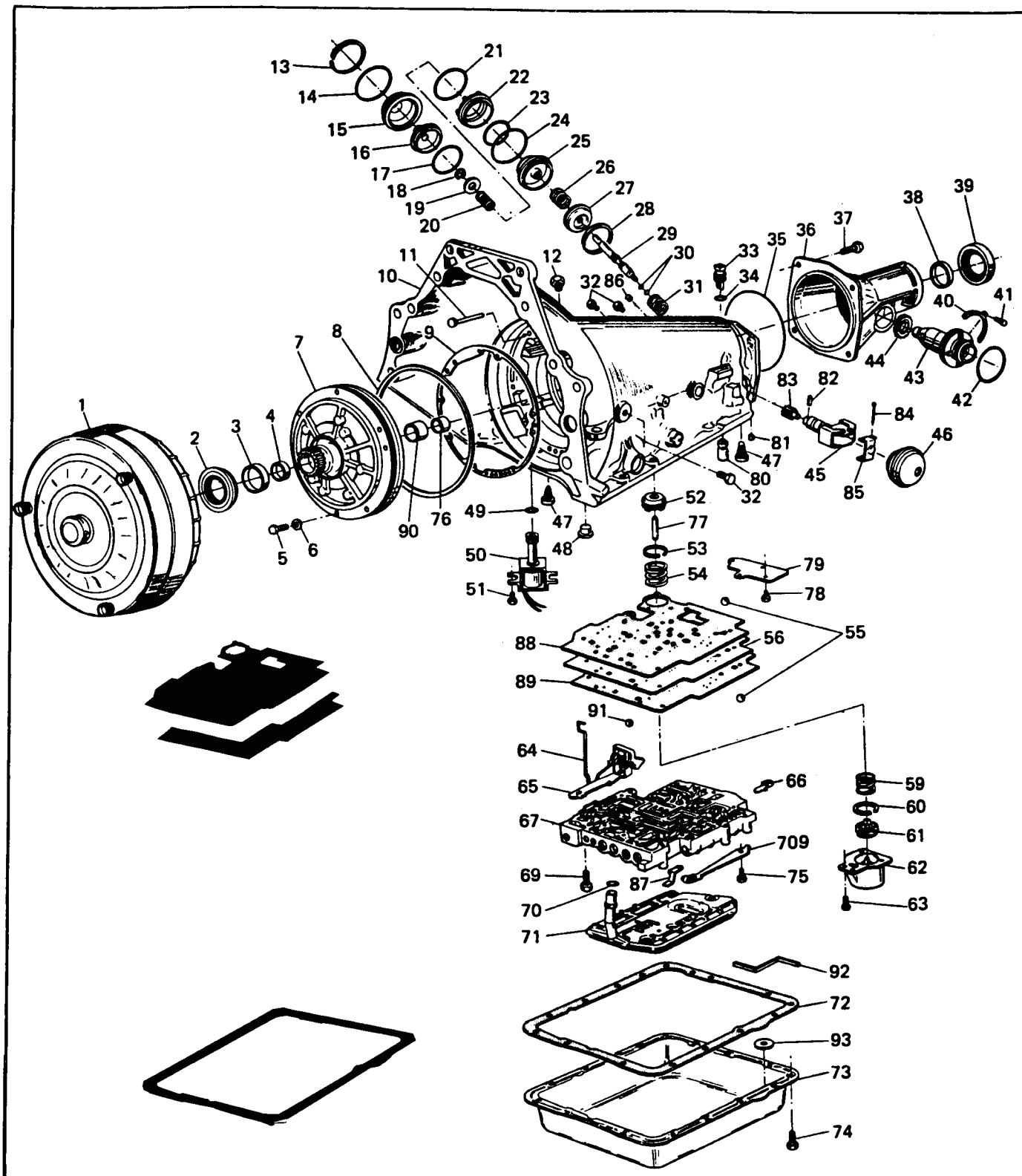

Figure 30

AUTOMATIC TRANSMISSION SERVICE GROUP



Technical Service Information

- | | |
|---------------------------------|------------------------------------|
| 1 TORQUE CONVERTER | 47 SCREEN, (SOLENOID & CONVERTER) |
| 2 FRONT PUMP SEAL | 48 BAND ANCHOR PIN |
| 3 FRONT PUMP BUSHING | 49 SOLENOID "O" RING |
| 4 STATOR BUSHING (FRONT) | 50 TCC SOLENOID ASSEMBLY |
| 5 FRONT PUMP BOLT (7) | 51 SOLENOID BOLT (2) |
| 6 FRONT PUMP WASHER (7) | 52 3-4 ACCUMULATOR PISTON |
| 7 FRONT PUMP ASSEMBLY | 53 3-4 ACCUMULATOR SEAL |
| 8 FRONT PUMP "O" RING | 54 3-4 ACCUMULATOR SPRING |
| 9 FRONT PUMP GASKET | 55 CHECK BALL, 1/4" Dia. (8) |
| 10 TRANSMISSION CASE | 56 SPACER PLATE |
| 11 VENT PIPE | 59 1-2 ACCUMULATOR SPRING |
| 12 COOLER LINE FITTING | 60 1-2 ACCUMULATOR SEAL |
| 13 SERVO COVER SNAP RING | 61 1-2 ACCUMULATOR PISTON |
| 14 SERVO COVER "O" RING | 62 1-2 ACCUMULATOR COVER |
| 15 2-4 SERVO COVER | 63 ACCUMULATOR COVER BOLT |
| 16 4TH APPLY PISTON | 64 LINK, (THROTTLE LEVER TO CABLE) |
| 17 4TH APPLY SEALING RING | 65 THROTTLE LEVER BRACKET ASSEMBLY |
| 18 "E" CLIP (APPLY PIN) | 66 WIRE HARNESS CLIP |
| 19 SERVO APPLY PIN WASHER | 67 VALVE BODY ASSEMBLY |
| 20 SERVO SPRING | 69 VALVE BODY BOLT (16) |
| 21 2ND HOUSING "O" RING | 70 FILTER "O" RING |
| 22 2ND HOUSING (INNER) | 71 FILTER ASSEMBLY |
| 23 2ND APPLY INNER SEAL | 72 OIL PAN GASKET |
| 24 2ND APPLY OUTER SEAL | 73 TRANSMISSION PAN |
| 25 2ND APPLY PISTON | 74 BOTTOM PAN BOLTS (16) |
| 26 SERVO CUSHION SPRING | 75 DETENT SPRING BOLT |
| 27 CUSHION SPRING RETAINER | 76 REAR CASE BUSHING |
| 28 SNAP RING (2ND APPLY PISTON) | 77 3-4 ACCUMULATOR PIN |
| 29 2-4 SERVO APPLY PIN (SEL) | 78 TENSION PLATE BOLT (VALVE BODY) |
| 30 2-4 SERVO APPLY PIN SEAL (2) | 79 SPACER PLATE TENSION PLATE |
| 31 SERVO RETURN SPRING | 80 3RD ACCUMULATOR BALL CAPSULE |
| 32 OIL PRESSURE PLUGS (4) | 81 ORIFICE CUP PLUG (3-4 ACCUM) |
| 33 ELECTRICAL CONNECTOR | 82 GOVERNOR ROLL PIN |
| 34 ELEC. CONN. "O" RING | 83 GOVERNOR GEAR |
| 35 EXTENSION HOUSING "O" RING | 84 GOVERNOR WEIGHT PIVOT PIN |
| 36 EXTENSION HOUSING | 85 GOVERNOR THRUST PLATE |
| 37 EXTENSION HOUSING BOLTS (4) | 86 ORIFICE CUP PLUG (2-4 SERVO) |
| 38 EXTENSION HOUSING BUSHING | 87 FILTER CLIP |
| 39 EXTENSION HOUSING SEAL | 88 SPACER PLATE TO CASE GASKET |
| 40 SPEEDO ADAPTER RETAINER | 89 SPACER PLATE TO V.B. GASKET |
| 41 SPEEDOMETER BOLT | 90 STATOR BUSHING (REAR) |
| 42 SPEEDO ADAPTER "O" RING | 91 CHECK BALL (TV EXHAUST) |
| 43 SPEEDOMETER ADAPTER | 92 SOLENOID HARNESS CONDUIT |
| 44 DRIVEN SPEEDOMETER GEAR | 93 BOTTOM PAN MAGNET |
| 45 GOVERNOR ASSEMBLY | 709 MANUAL DETENT SPRING |
| 46 GOVERNOR COVER | |

Figure 31

AUTOMATIC TRANSMISSION SERVICE GROUP

TRANSMISSION DISASSEMBLY

General Information

1. Thoroughly clean the exterior of the transmission.
2. Remove the torque converter.
3. Install holding fixture on to transmission case (Figure 32).
4. Install transmission into base on work bench (Figure 32).
5. Drain the transmission fluid.

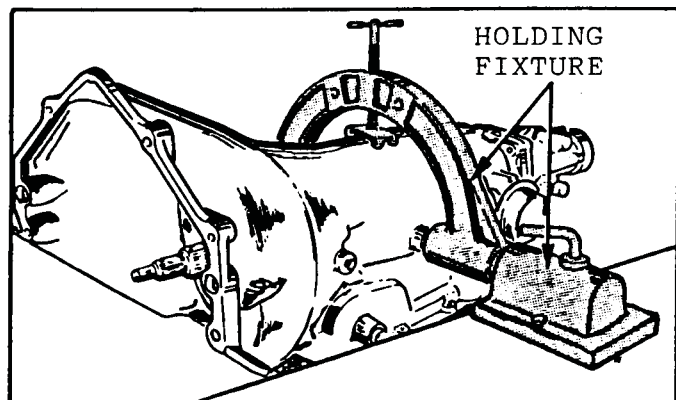

Figure 32

2-4 Servo Assembly

1. Install J-29714 servo cover compressor (Figure 33).
2. Remove servo cover snap ring.
3. Pull "O" ring up thru slot in case and cut, remove "O" ring.
4. Remove servo cover.
5. Remove 2-4 servo assembly.
6. Remove 4th apply piston.
7. Remove servo return spring.
8. Remove "E" clip, washer, and apply pin spring.
9. Remove 2nd apply piston from servo pin.
10. Install J-22269-01 on second apply piston as shown in Figure 34.
11. Remove second apply piston snap ring.
12. Remove cushion spring retainer and cushion spring.

SERVICE NOTE: As a diagnostic aid, the servo pin length should now be checked for proper selection. If the servo pin length is not proper, be certain to inspect the 2-4 band and reverse input housing for wear.

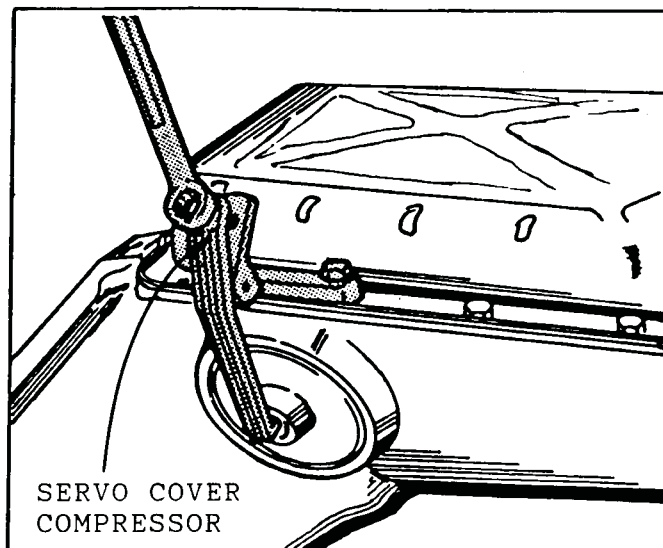

Figure 33

Band Pin Selection

1. Install J-33037 with apply pin as shown in Figure 37.
2. Apply 100 in. lbs. torque.
3. If white line appears in the window of tool, pin length is correct.
4. Use the pin selection chart in Figure 37 to determine correct pin length.

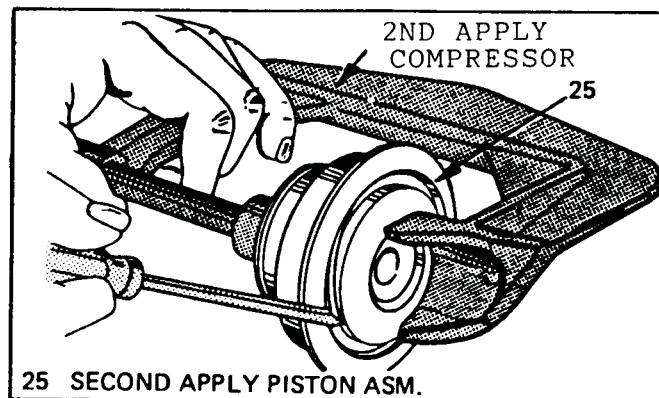
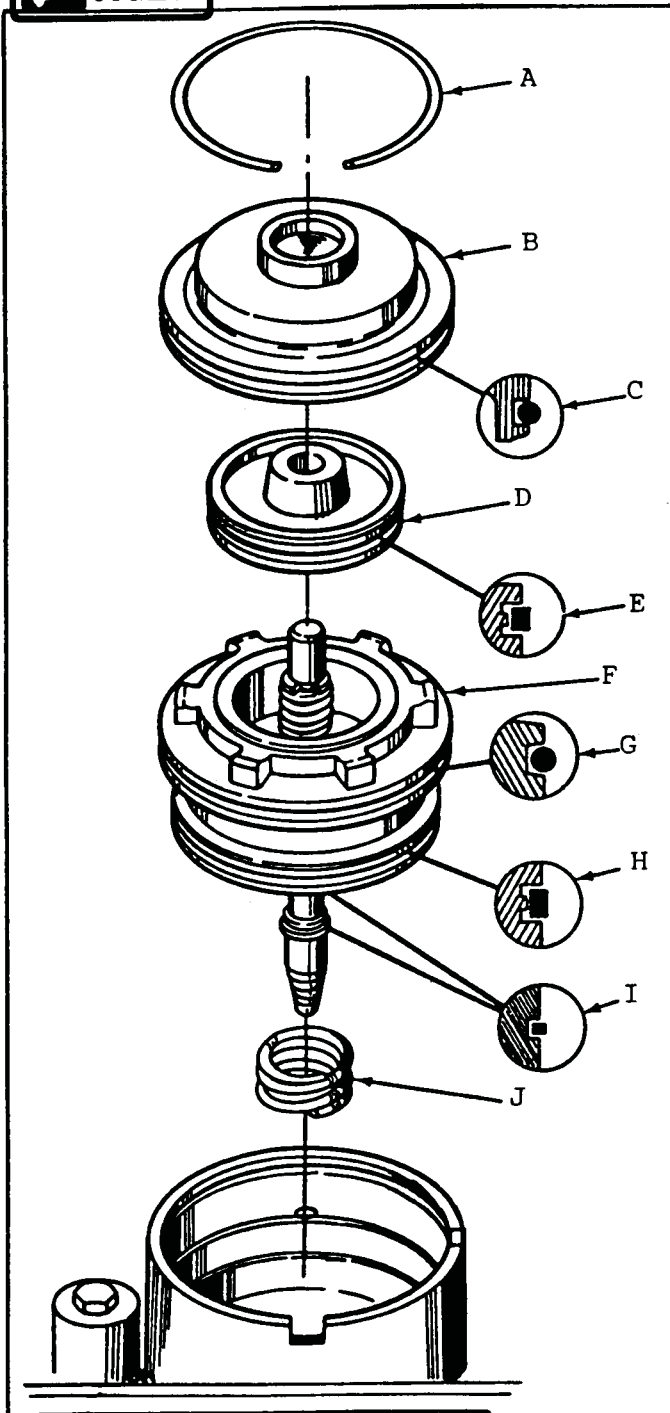
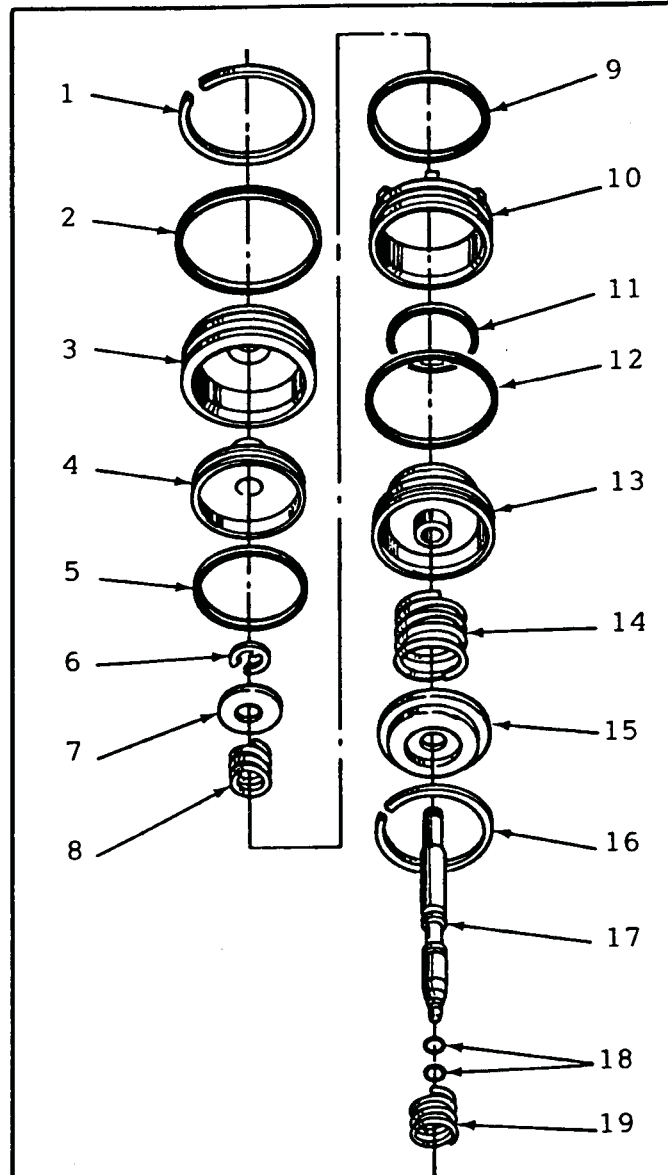

Figure 34



- A SERVO COVER SNAP RING
- B SERVO COVER
- C SERVO COVER "O" RING
- D 4TH APPLY PISTON
- E 4TH APPLY PISTON SEAL RING
- F SERVO PISTON INNER HOUSING
- G INNER HOUSING "O" RING
- H 2ND APPLY PISTON OUTER SEAL
- I APPLY PIN SEALING RINGS
- J SERVO RETURN SPRING

Figure 35



- 1 SERVO COVER SNAP RING
- 2 SERVO COVER "O" RING
- 3 2-4 SERVO COVER
- 4 4TH APPLY PISTON
- 5 4TH APPLY PISTON SEAL RING
- 6 APPLY PIN "E" CLIP
- 7 APPLY PIN WASHER
- 8 APPLY PIN SPRING
- 9 SERVO INNER HOUSING "O" RING
- 10 SERVO INNER HOUSING
- 11 2ND APPLY PISTON INNER SEAL
- 12 2ND APPLY PISTON OUTER SEAL
- 13 2ND APPLY PISTON
- 14 2ND APPLY CUSHION SPRING
- 15 CUSHION SPRING RETAINER
- 16 2ND APPLY PISTON SNAP RING
- 17 2-4 SERVO APPLY PIN(SELECTIVE)
- 18 SERVO PIN SEALING RINGS
- 19 SERVO RETURN SPRING

Figure 36

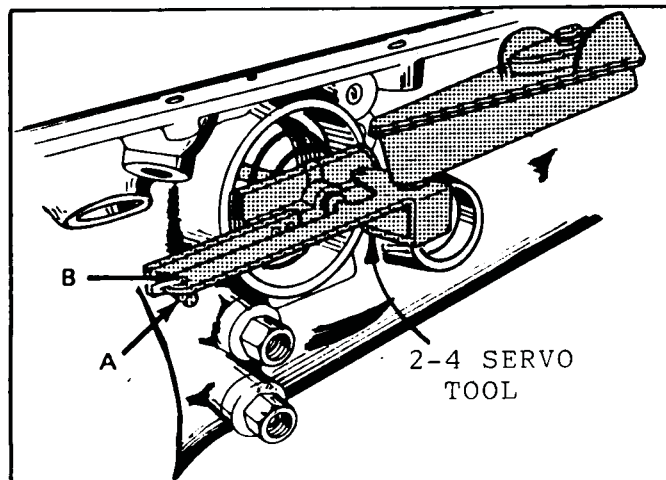

A WHITE LINE
B WINDOW

2-4 SERVO PIN SELECTION

PIN LENGTH		PIN I.D.
mm	INCH	
66.37-66.67	2.61-2.62	2 RINGS
67.74-68.04	2.67-2.68	3 RINGS
69.11-69.41	2.72-2.73	WIDE BAND

Figure 37

Extension Housing and Governor

1. Remove extension housing bolts and extension housing.
2. Remove and discard extension housing "O" ring.
3. Remove output shaft sleeve if so equipped.
4. Push down on tab of speedo clip, and tap speedometer gear off of the output shaft using care not to damage the speedo gear.
5. Tap around the governor cover flange with a punch to remove the governor cover. Care must be used so as not to damage the governor cover.
6. Remove the governor and inspect for damage or wear, and inspect case bore for wear or damage.

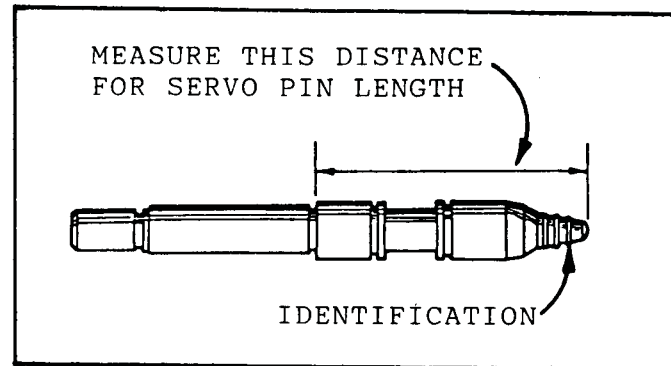
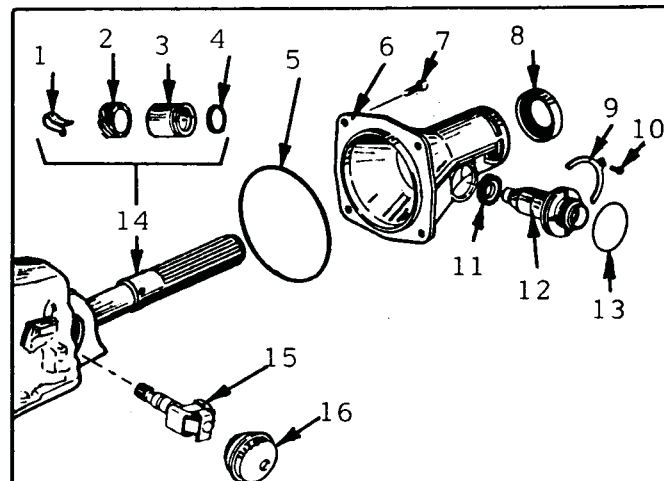

Figure 38



- 1 SPEEDOMETER DRIVE GEAR CLIP
- 2 SPEEDOMETER DRIVE GEAR
- *3 OUTPUT SHAFT SLEEVE
- *4 OUTPUT SLEEVE "O" RING
- 5 EXTENSION HOUSING "O" RING
- 6 EXTENSION HOUSING
- 7 EXTENSION HOUSING BOLT (4)
- 8 EXTENSION HOUSING SEAL
- 9 SPEEDO ADAPTER RETAINER
- 10 RETAINER BOLT
- 11 SPEEDOMETER DRIVEN GEAR
- 12 SPEEDOMETER ADAPTER
- 13 SPEEDO ADAPTER "O" RING
- 14 OUTPUT SHAFT
- 15 GOVERNOR
- 16 GOVERNOR COVER

*NOT USED ON ALL MODELS

Figure 39

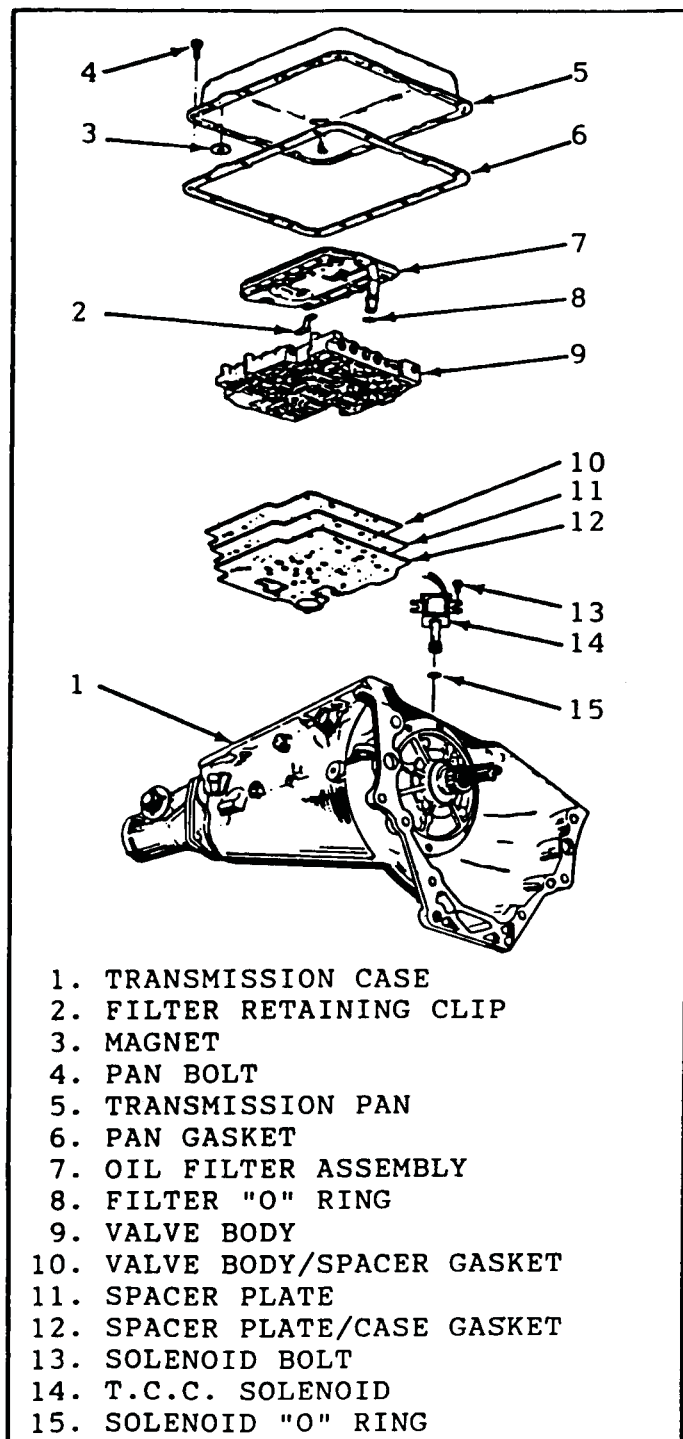
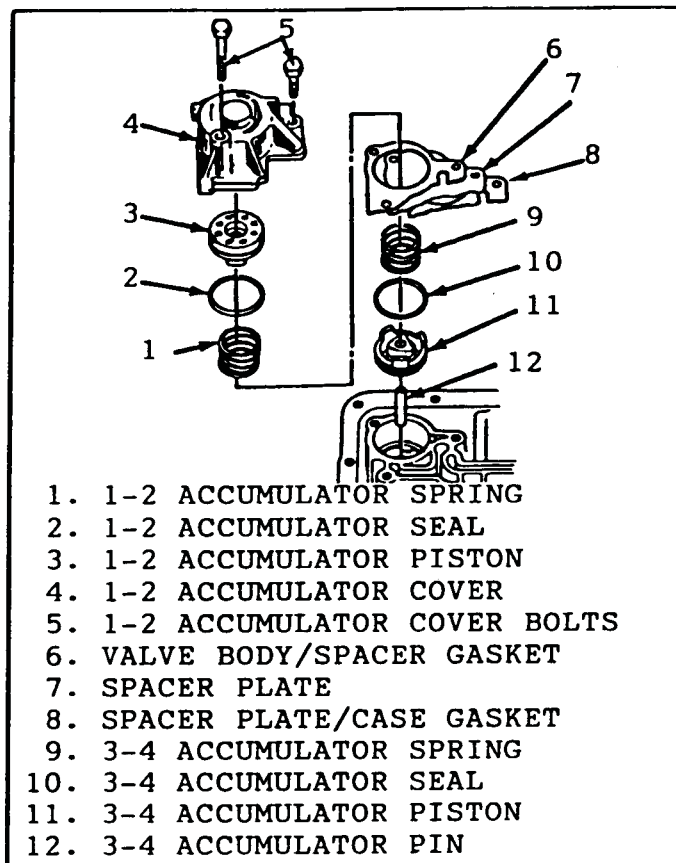

Figure 40

VALVE BODY AND WIRING HARNESS

1. Remove pan bolts, oil pan, and discard pan gasket.
2. Remove oil filter, and "O" ring. "O" ring seal may stick in the bore of the pump cover.



1. 1-2 ACCUMULATOR SPRING
2. 1-2 ACCUMULATOR SEAL
3. 1-2 ACCUMULATOR PISTON
4. 1-2 ACCUMULATOR COVER
5. 1-2 ACCUMULATOR COVER BOLTS
6. VALVE BODY/SPACER GASKET
7. SPACER PLATE
8. SPACER PLATE/CASE GASKET
9. 3-4 ACCUMULATOR SPRING
10. 3-4 ACCUMULATOR SEAL
11. 3-4 ACCUMULATOR PISTON
12. 3-4 ACCUMULATOR PIN

Figure 41

3. Remove solenoid bolts, solenoid and wiring harness assembly.
NOTE: See Figure 18 for identification of solenoids and wiring harness.
4. Remove case connector and "O" ring seal.
5. Remove 1-2 accumulator cover bolts and 1-2 accumulator cover.
6. Remove 1-2 accumulator piston, seal, and spring.
7. Remove tension plate bolts, and tension plate.
8. Remove manual detent spring.
9. Remove T.V. lever and bracket assembly (See Figure 42).
10. Remove remaining valve body bolts.
11. Lift valve body straight up and off of manual valve link, and set valve body aside.
12. Remove three checkballs from top of spacer plate.
13. Remove spacer plate and both spacer plate gaskets.
14. Remove checkballs from the case with pencil magnet.

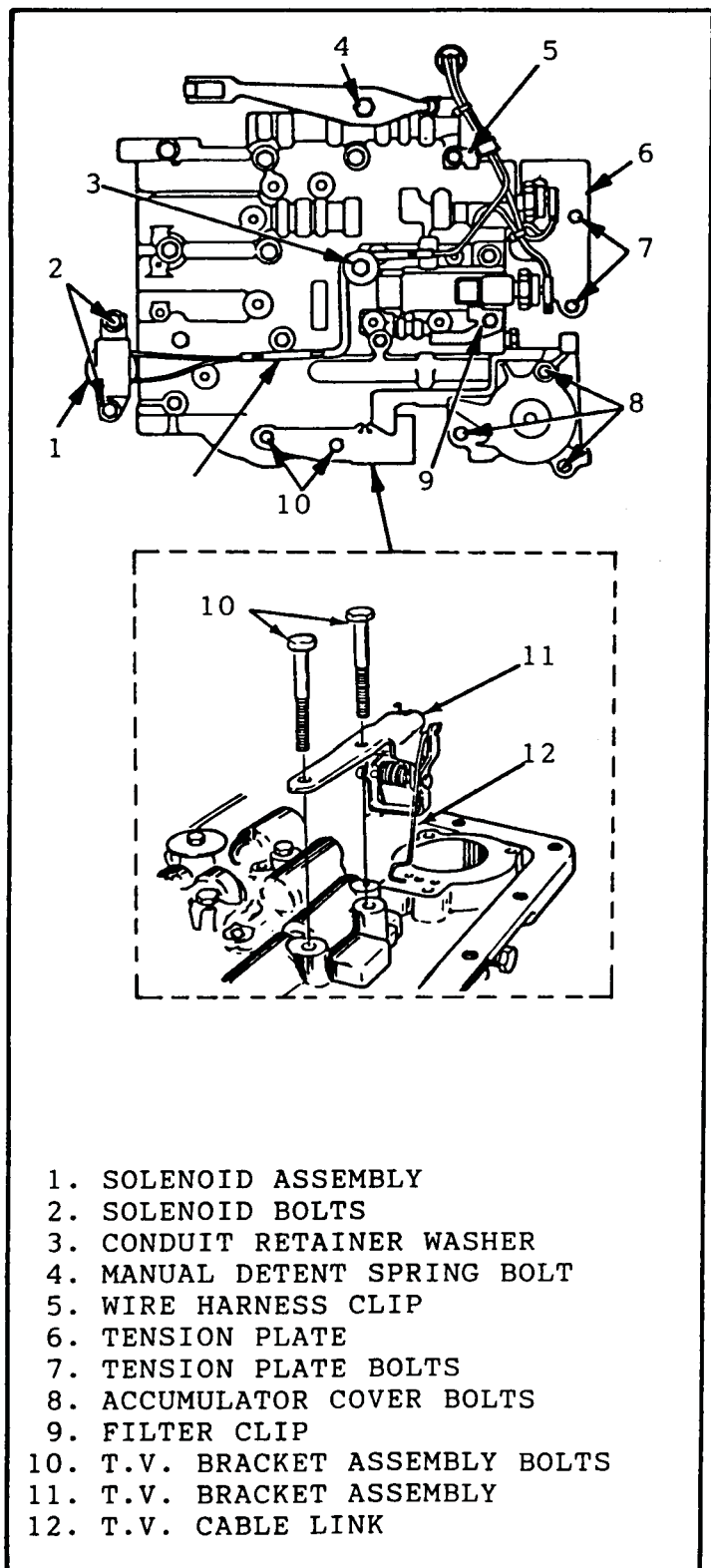

Figure 42

1. SOLENOID ASSEMBLY
2. SOLENOID BOLTS
3. CONDUIT RETAINER WASHER
4. MANUAL DETENT SPRING BOLT
5. WIRE HARNESS CLIP
6. TENSION PLATE
7. TENSION PLATE BOLTS
8. ACCUMULATOR COVER BOLTS
9. FILTER CLIP
10. T.V. BRACKET ASSEMBLY BOLTS
11. T.V. BRACKET ASSEMBLY
12. T.V. CABLE LINK

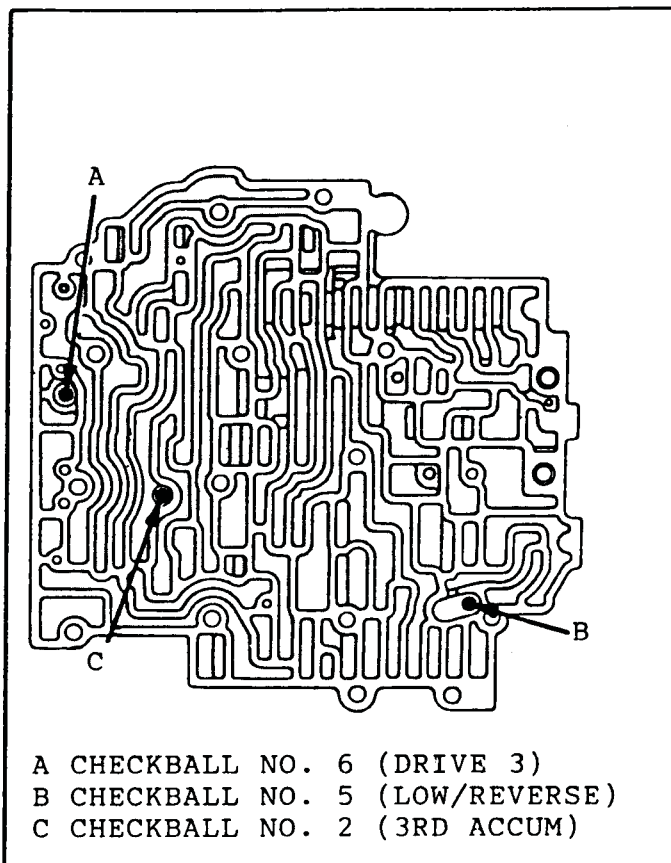

Figure 43

- A CHECKBALL NO. 6 (DRIVE 3)
 B CHECKBALL NO. 5 (LOW/REVERSE)
 C CHECKBALL NO. 2 (3RD ACCUM)

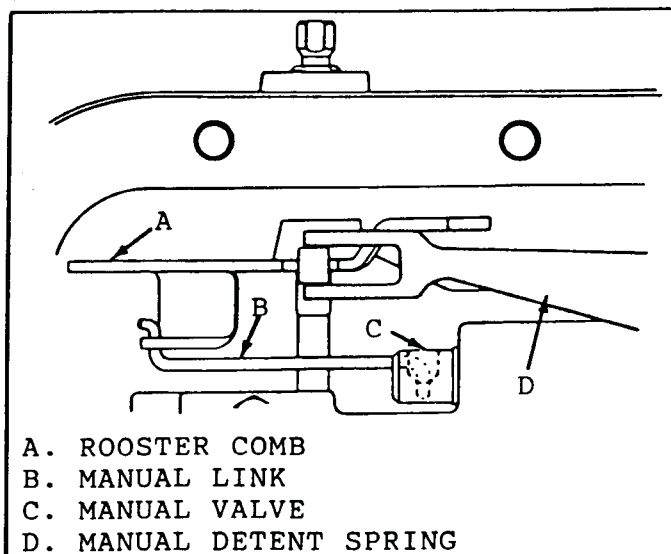

Figure 44

- A. ROOSTER COMB
 B. MANUAL LINK
 C. MANUAL VALVE
 D. MANUAL DETENT SPRING

15. The larger checkball in the case is the TV exhaust ball, and we recommend that you omit this ball. (Figure 45)
16. Remove and inspect the converter clutch and the governor screens (Figure 45).
17. Remove 3-4 accumulator spring, piston, and pin.

IMPORTANT!

Transmission End Play Check:

As a diagnostic aid, transmission end play should be checked before removing the pump assembly.

CHECKING TRANSMISSION END PLAY

1. Remove a front pump bolt and install an 11" bolt and lock nut (Figure 47).
2. Install J-25022-A adapter, or J-34725 adapter, as shown in Figure 46 on turbine shaft.
3. Install pump remover J-24773-A as shown in Figure 47.
4. Install dial indicator, and set to zero.
5. Pull up on pump remover, and record end play.
6. End play should be .005" min, to .036" max.

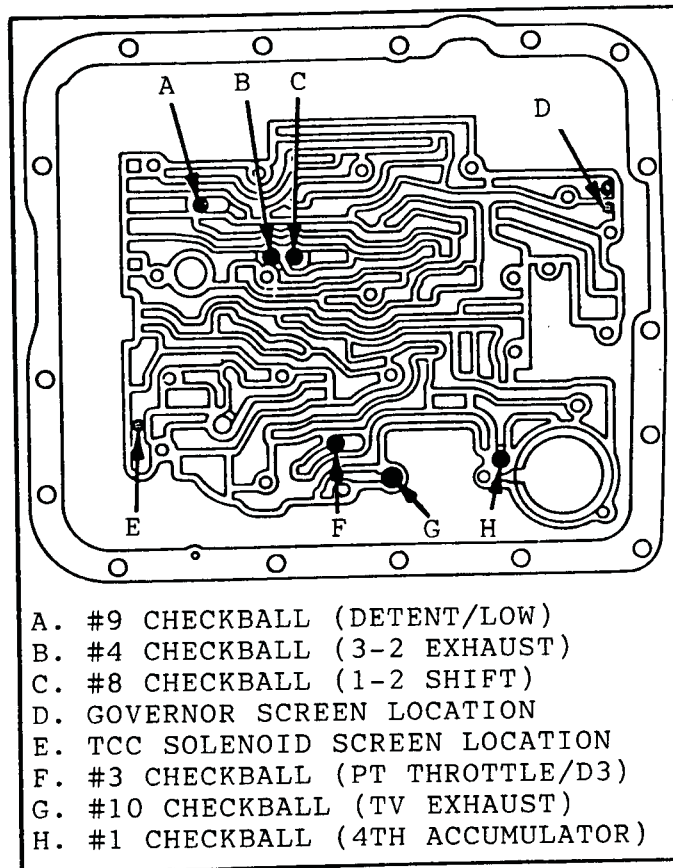

Figure 45

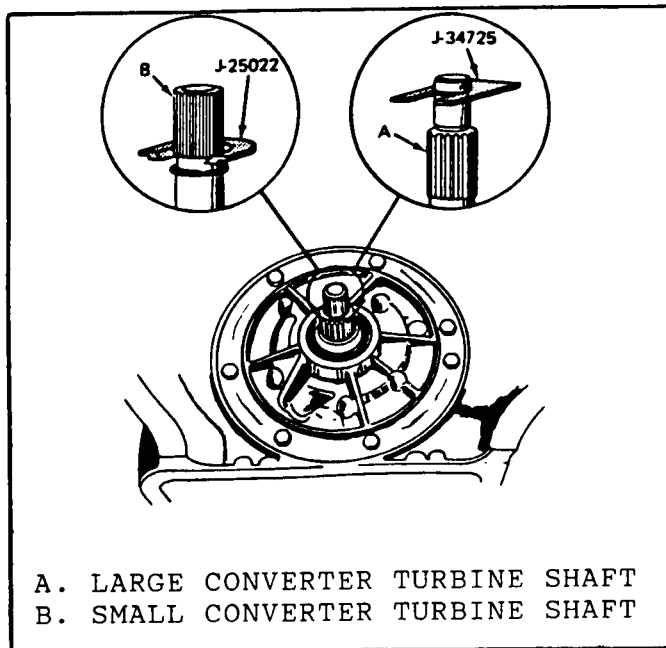

Figure 46

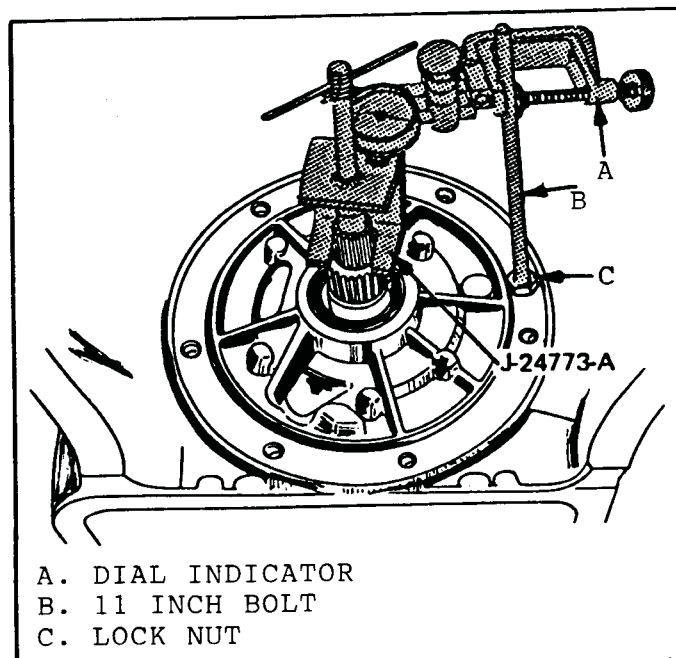

Figure 47

OIL PUMP ASSEMBLY

1. Remove all remaining front pump retaining bolts.
2. Install J-24773-A oil pump remover (Figure 48).
3. Remove "O" ring seal from turbine shaft.
4. Remove oil pump assembly.
NOTE: The solenoid assembly and oil filter must be removed before oil pump removal.
4. Remove and discard pump gasket and "O" ring to case seal.
5. Remove and discard Teflon seal rings from pump tower.
6. Remove reverse input drum to oil pump thrust washer.

REVERSE INPUT DRUM, INPUT HOUSING, 2-4 BAND, AND INPUT GEAR SET.

1. Remove band anchor pin (See Figure 49).
2. Remove the 2-4 band assembly.
3. Grasp the turbine shaft and lift straight up, removing the input housing and reverse input drum together.
4. Remove input sun gear.
5. Remove input carrier thrust washer (Black).
6. Install J-29837 output shaft support fixture, as shown in Figure 50.
NOTE: Output shaft may fall out when input carrier snap ring is removed, if fixture is not used.
7. Remove input carrier to output shaft snap ring using snap ring pliers. Use care not to overexpand the snap ring.
8. Remove the input carrier, and input ring gear and ring gear support as an assembly.
9. Remove ring gear support thrust washer, and sun gear shell.
10. Remove reaction sun gear, and thrust washer on top of low roller clutch inner race.
11. Remove the low roller clutch inner race.

IMPORTANT!

If the output shaft has not yet separated from the reaction ring gear, leave it in place, as we can use it to remove the reaction carrier, 1^o/reverse clutches, and low roller clutch support. The manufacturer assembles the output shaft and reaction ring gear with adhesive for ease of assembly.

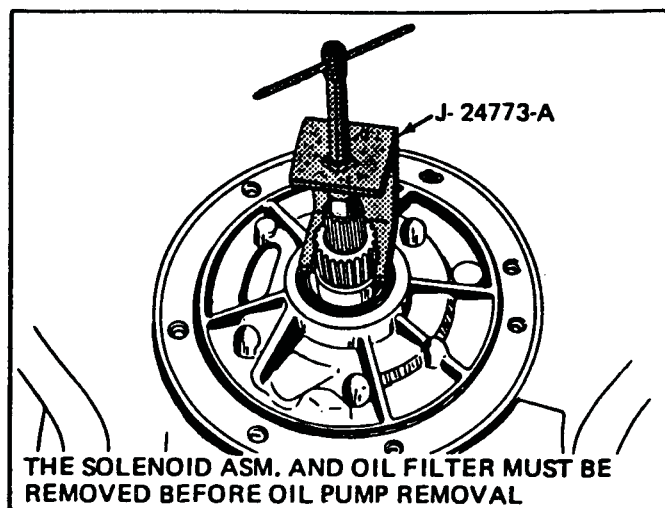

Figure 48

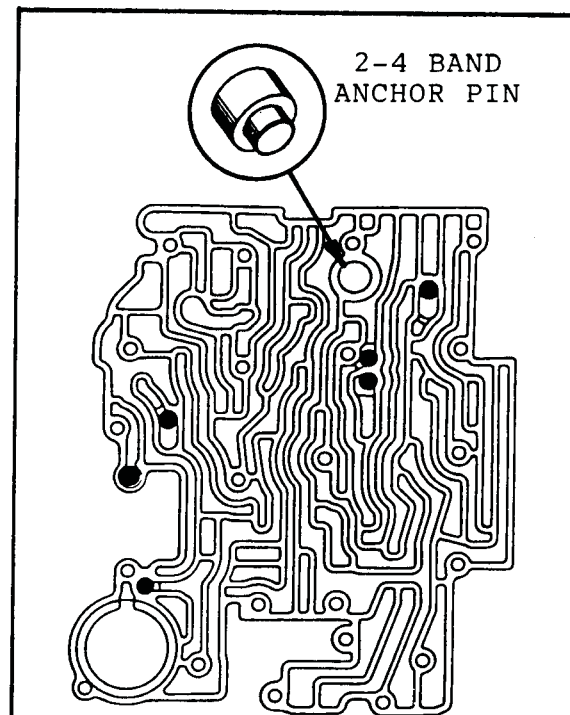

Figure 49

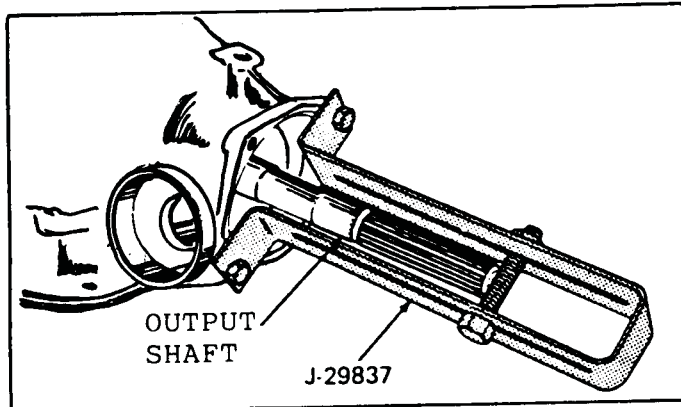

Figure 50

LOW-REVERSE CLUTCHS AND REACTION GEAR SET

1. Remove low and reverse support snap ring from case.
2. Remove "Anti-Clunk" spring from between support and case.
3. Remove low-reverse roller clutch support (Center Support).
4. Remove reaction carrier.
5. Remove low-reverse clutches.
6. Remove reaction ring gear, and bearings.

NOTE: If the output shaft has not yet been separated from the reaction ring gear, grasp the output and lift up to remove the low roller support, low-reverse clutch, reaction carrier, and reaction ring gear all at one time.

LOW-REVERSE CLUTCH PISTON

1. Remove parking lock bracket from case.
2. Install clutch spring compressor.
3. Remove low-reverse retainer snap ring, and remove compressor.
4. Remove low-reverse return spring assembly.
5. Remove low-reverse piston and seals by blowing air into low-reverse apply passage (Figure 54)

NOTE: The parking pawl may have to be removed before removing the low-reverse piston, due to interference.

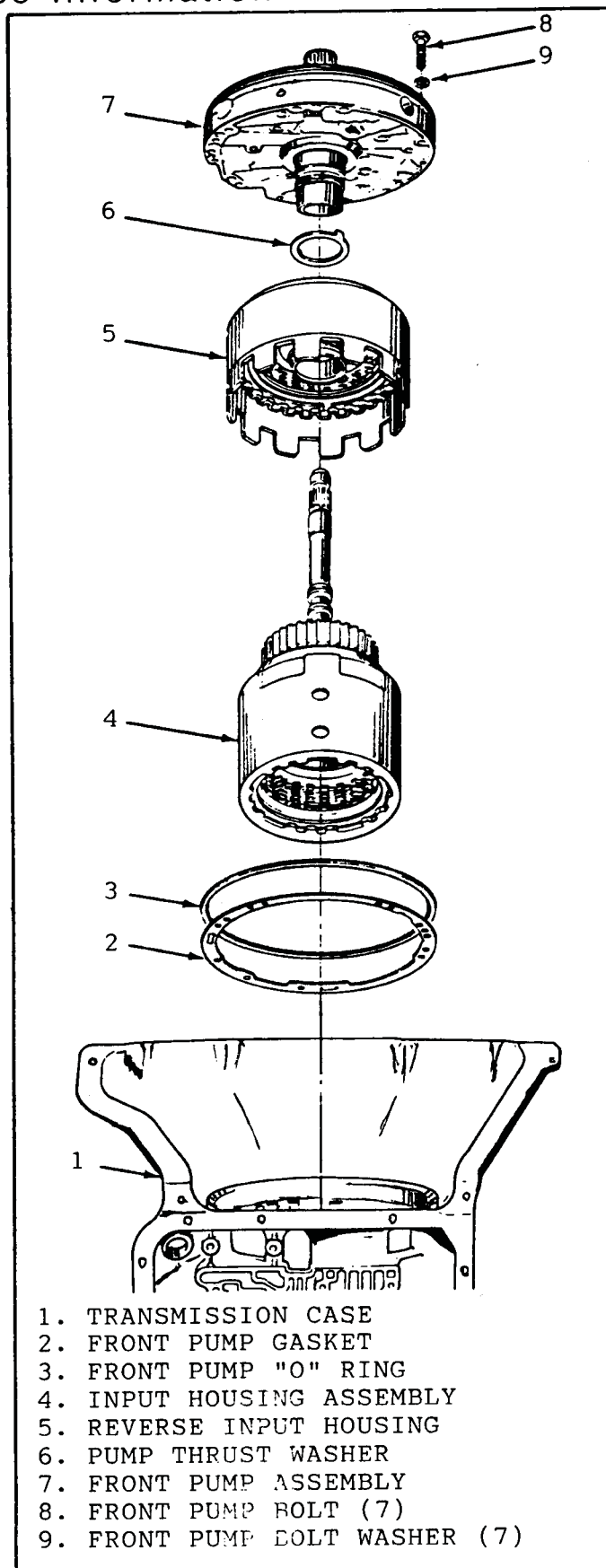
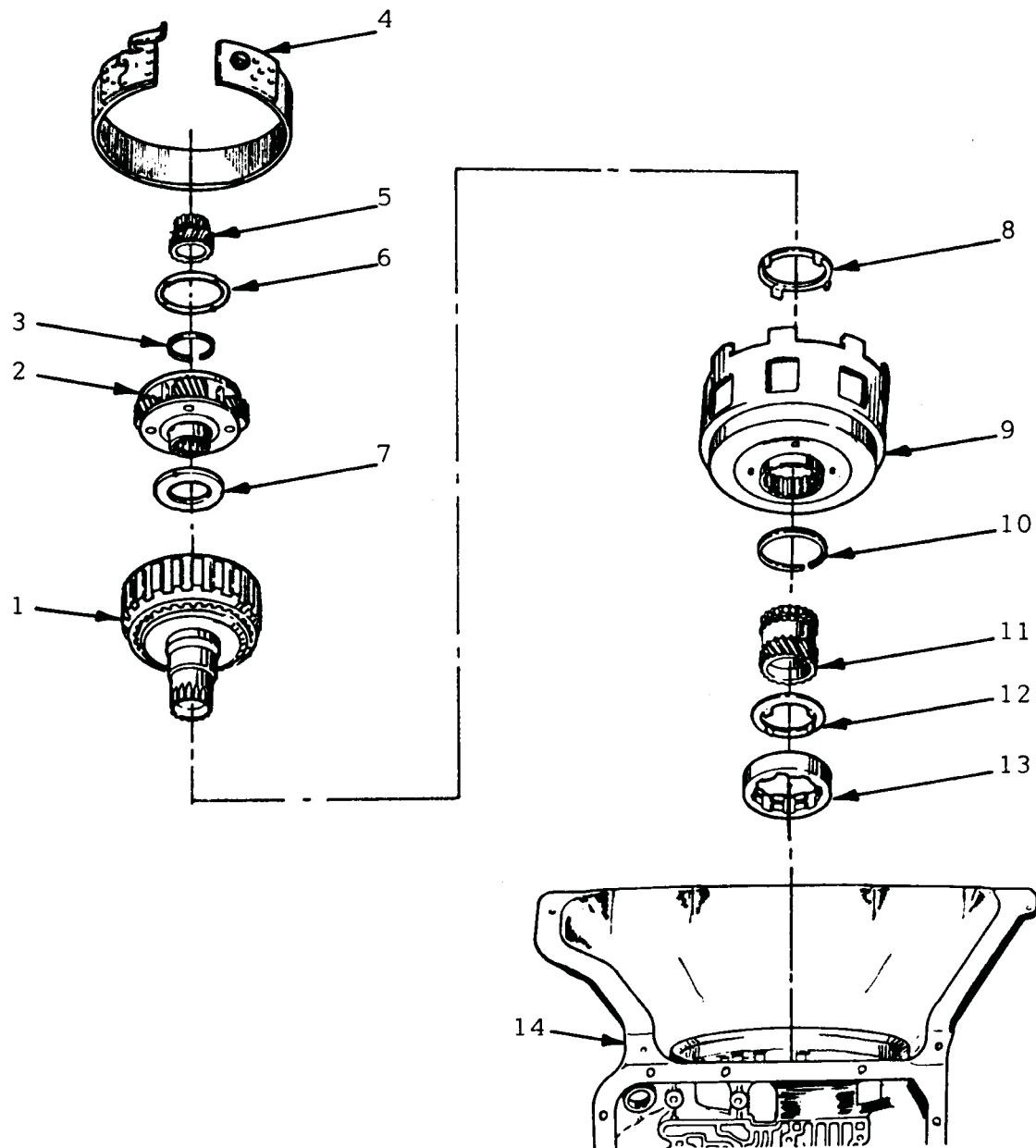

Figure 51



1. INPUT RING GEAR
2. INPUT CARRIER
3. INPUT CARRIER SNAP RING
4. 2-4 BAND ASSEMBLY
5. INPUT SUN GEAR
6. INPUT CARRIER THRUST WASHER
7. INPUT CARRIER BEARING

8. SUN GEAR SHELL/RING GEAR WASHER
9. SUN GEAR SHELL
10. REACTION SUN GEAR SNAP RING
11. REACTION SUN GEAR
12. SUN GEAR/INNER RACE WASHER
13. LOW ROLLER CLUTCH INNER RACE
14. TRANSMISSION CASE

Figure 52

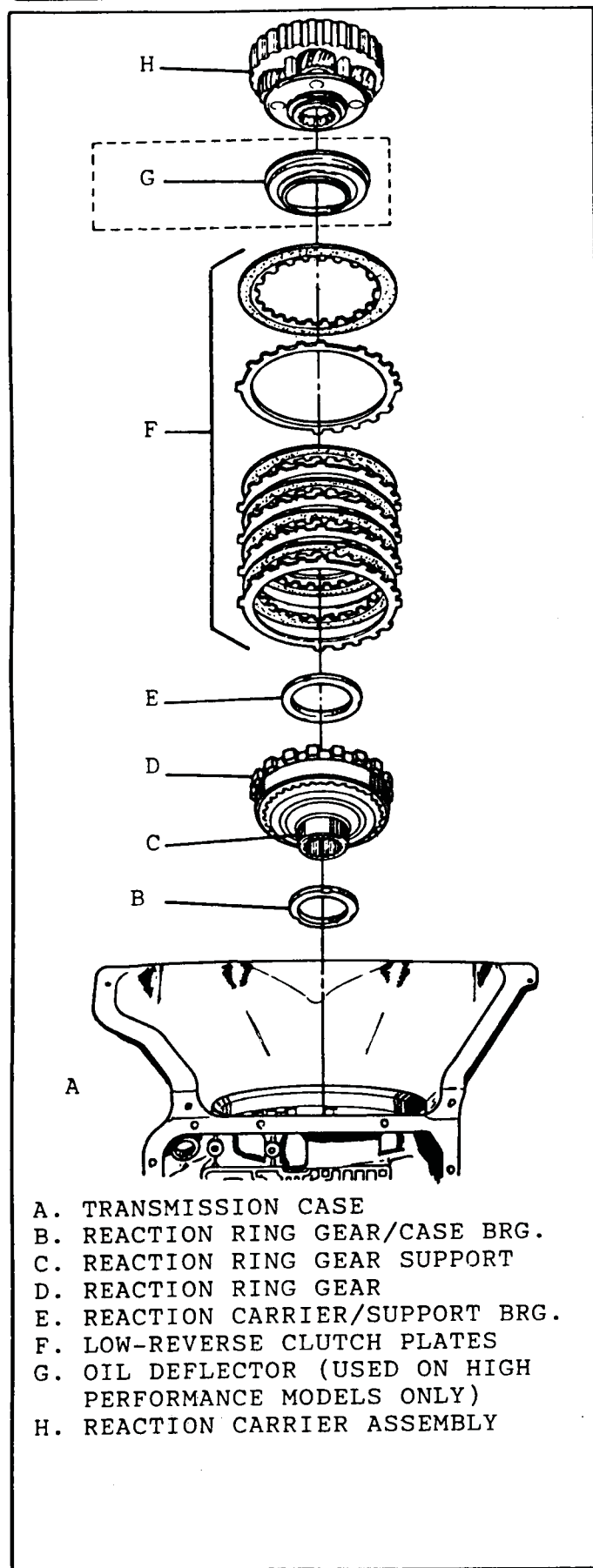

Figure 53

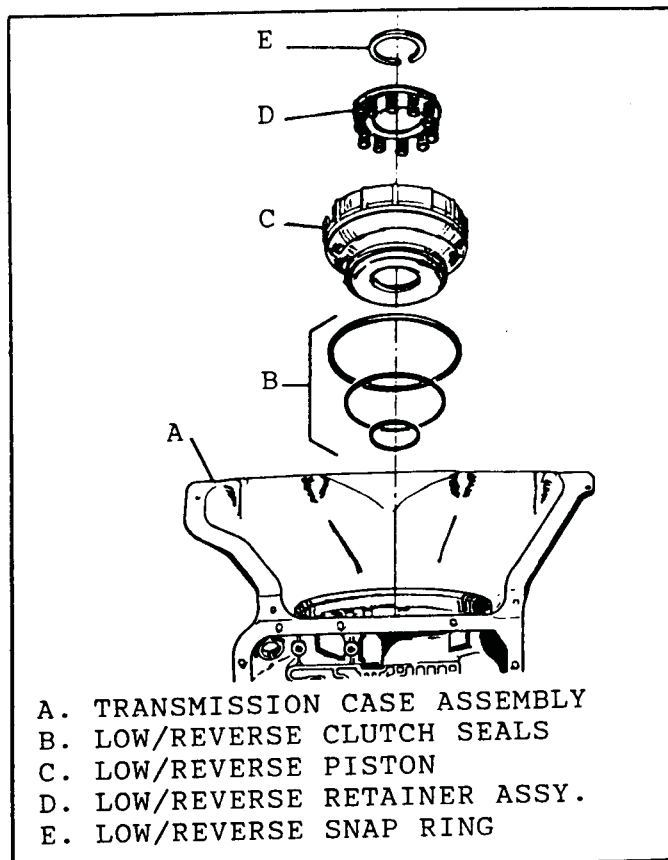

Figure 54

LO & REVERSE CLUTCH PISTON	
MODEL	PISTON DIMENSION *A
4 CLUTCH PACK	2.398"
5 CLUTCH PACK	2.225"

C. LOW/REVERSE CLUTCH PISTON

Figure 55

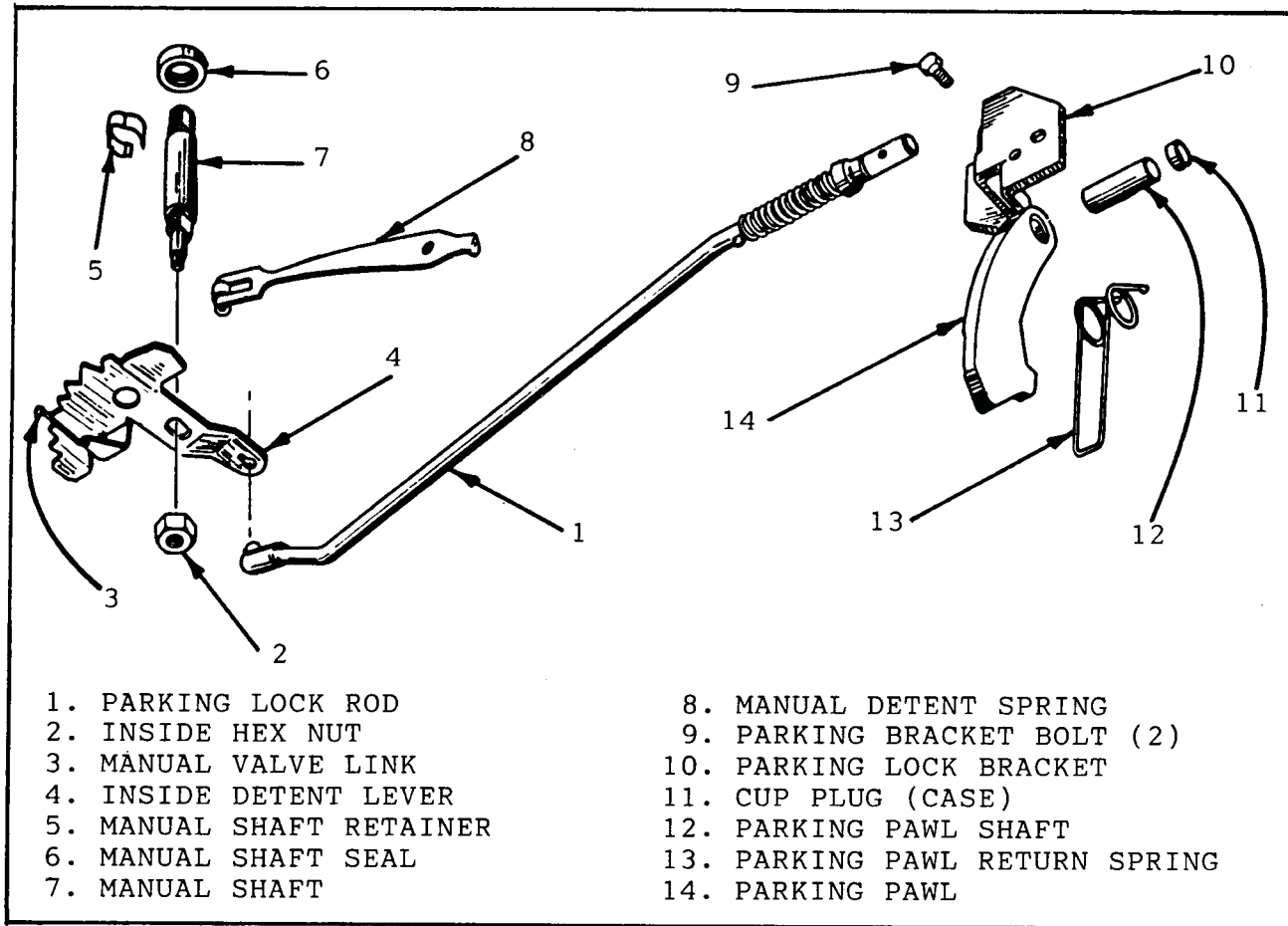

Figure 56

PARKING LINKAGE COMPONENTS

1. Remove bolts and parking lock bracket from case.
2. Remove parking pawl shaft cup plug from case with a #4 screw extractor.
3. Remove parking pawl pivot shaft with a pencil magnet.
4. Remove parking pawl and parking pawl return spring.
5. Remove inside manual shaft nut.
6. Remove inside detent lever and parking lock rod.
7. Remove manual shaft retainer.
8. Remove manual shaft.
9. Remove manual shaft seal by prying out with a screwdriver.
10. Refer to Figures 56 and 57.

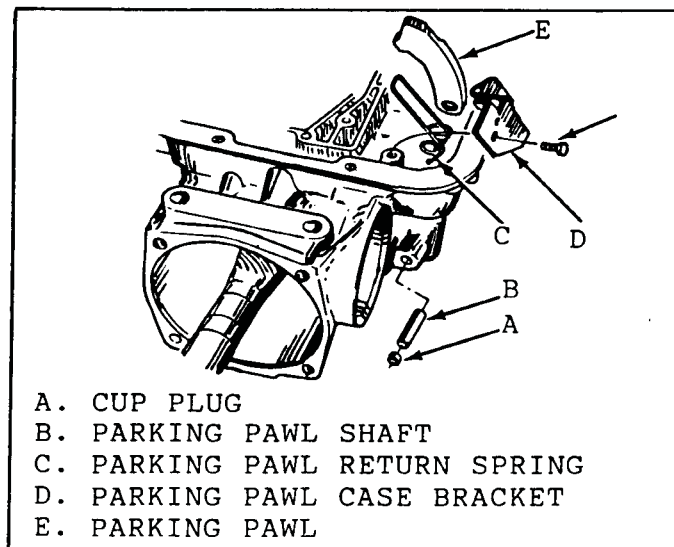

Figure 57



Technical Service Information

COMPONENT REPAIR AND REASSEMBLY

1. Thoroughly clean all parts.
2. Inspect transmission case for the following:
 - * Exterior for cracks, porosity, or damage.
 - * Valve body surface for damage, interconnected oil passages, and straightedge this surface.
 - * Vent assembly for damage.
 - * Air check all oil passages to insure they are open.
 - * 2-4 Servo bore for damage, wear, or porosity.
 - * Orifice cup plug in servo bore for debris or damage.
 - * 3rd accumulator ball capsule for missing, sticking, or leaking.
 - * Orifice cup plug in 3-4 accumulator bore for debris.
 - * Speedometer bore for damage.
 - * All bolt holes for thread damage (Heli-coil if necessary).
 - * Cooler line fittings for damage, and proper torque.
 - * Case interior for damaged snap ring grooves, clutch plate lugs worn, case bushing for wear, and governor support pin installation depth.
3. Install new manual shaft seal in case (Use 9/16" socket to install and fully seat seal).
4. Install manual shaft, inside detent lever, park rod, and inside manual shaft nut. Make certain that flats of inside detent lever are engaged on flats of manual shaft, before nut is tightened.
5. Torque nut to 23 ft. lbs.
6. Install manual shaft retainer onto manual shaft.

LOW AND REVERSE PISTON

1. Inspect low/reverse piston for cracks or damage.
2. Install new seals (3) on low-reverse piston and coat seals with a light coat of lubricant.
3. Install low/reverse piston into case.

4. Install return spring, and retainer assembly.
5. Install clutch spring compressor, and install L/R snap ring.
6. Remove spring compressor.

PARKING PAWL

1. Inspect parking pawl and all components for wear or damage.
2. Install parking pawl and pawl return spring into case.
3. Install parking pawl pivot shaft into case and thru the parking pawl.
4. Install cup plug into case with sealer to prevent leakage.
5. Check parking linkage for proper operation.

3RD ACCUMULATOR BALL CAPSULE LEAK CHECKING PROCEDURE

1. Install the 2-4 servo assembly into the servo bore.
2. Install the servo cover and snap ring.
3. Pour a suitable solvent into the 3rd Accum. passage (Refer to Figure 58).
4. Watch for leakage inside the transmission case (Figure 58).
5. If leakage is seen from the exhaust hole in the case bore, replace the 3rd accumulator ball capsule assembly with part number 8634400.

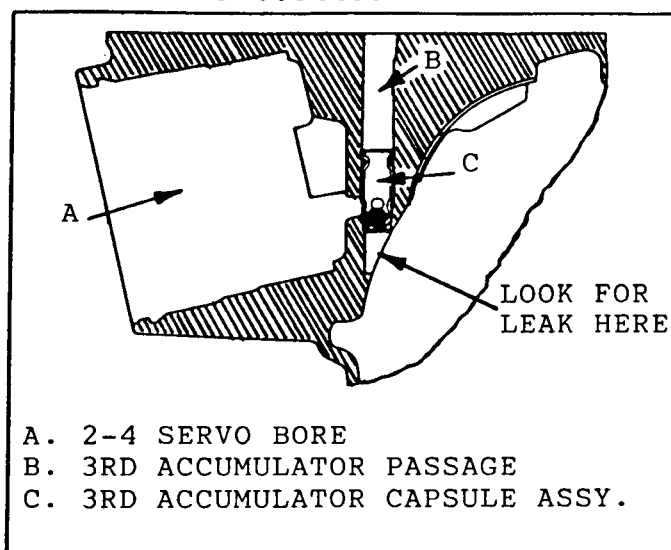

Figure 58



Technical Service Information

REPLACEMENT PROCEDURE - 3RD ACCUM. BALL CAPSULE ASSEMBLY

1. Remove defective ball capsule assembly with a #4 screw extractor.
2. Install new ball capsule Assy. into case, seat end first. Part No. for new capsule is 8634400.
3. Using a 3/8" diameter steel rod, drive ball capsule assembly down into case until it is 1 5/8" below worm track surface.
4. Oil feed slots in the capsule assembly must line up with oil passage in the servo bore, as shown in Figure 59 "D".

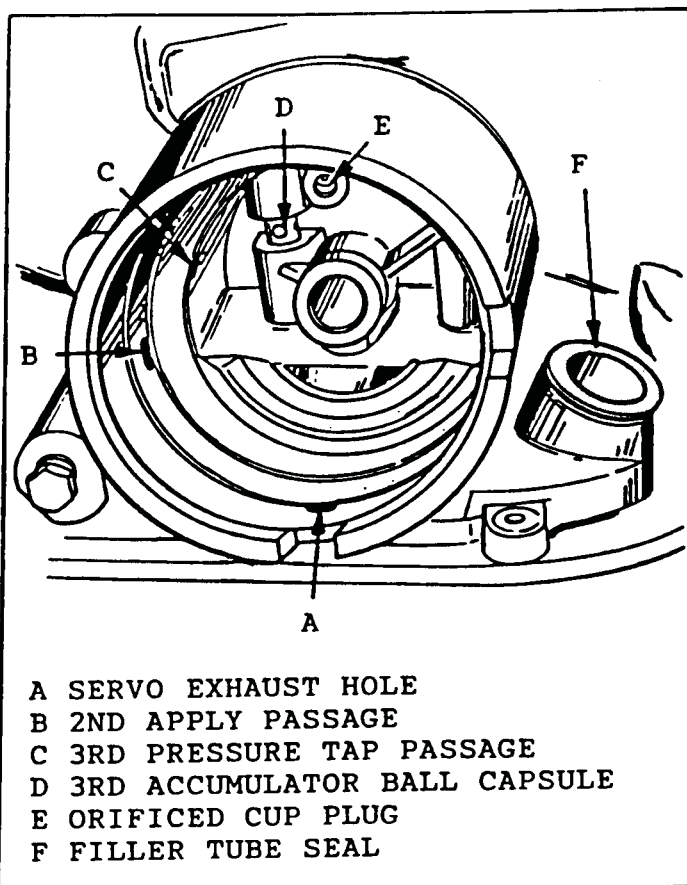

Figure 59

REACTION GEAR SET AND LOW REVERSE CLUTCHS

1. Inspect the following:
 - *Reaction ring gear and ring gear support for cracks, stripped splines, teeth or park lug damage.
 - *Thrust bearing assembly for damage or wear.
 - *Reaction carrier assembly for pinion gear damage, proper pinion staking, stripped splines, peening on clutch lugs, and for excessive pinion washer wear. Pinion end play is .008"/.024" (See Figure 60).
 - *To check the trapped thrust bearing in the carrier for wear place a bushing or output shaft sleeve on the bearing race (Do not contact the pinion gears), and turn it with the palm of your hand. Any imperfections will be felt through the sleeve. (See Figure 61).
2. Install bearing on back of reaction ring gear support as shown in Figure 62, (Retain with a light coat of petrolatum), and install in case.
3. Install thrust bearing into front side of ring gear support as shown in Figure 62.
4. Install reaction carrier onto the thrust bearing.
5. Install low/reverse clutch plates beginning with a steel plate (Figure 63) and alternating with a lined plate. The number of plates will be determined by the L/R piston height, as shown in Figure 55.
6. Install anti-clunk spring into case as shown in Figure 64. Retain with petrolatum.

LOW AND REVERSE SUPPORT ASSEMBLY

1. Inspect the following:
 - *Low roller inner race for damage surface finish.
 - *Roller clutch assembly for damaged rollers or broken springs.
 - *Cam and support assembly for loose cam, surface finish, and cracked or damaged lugs.

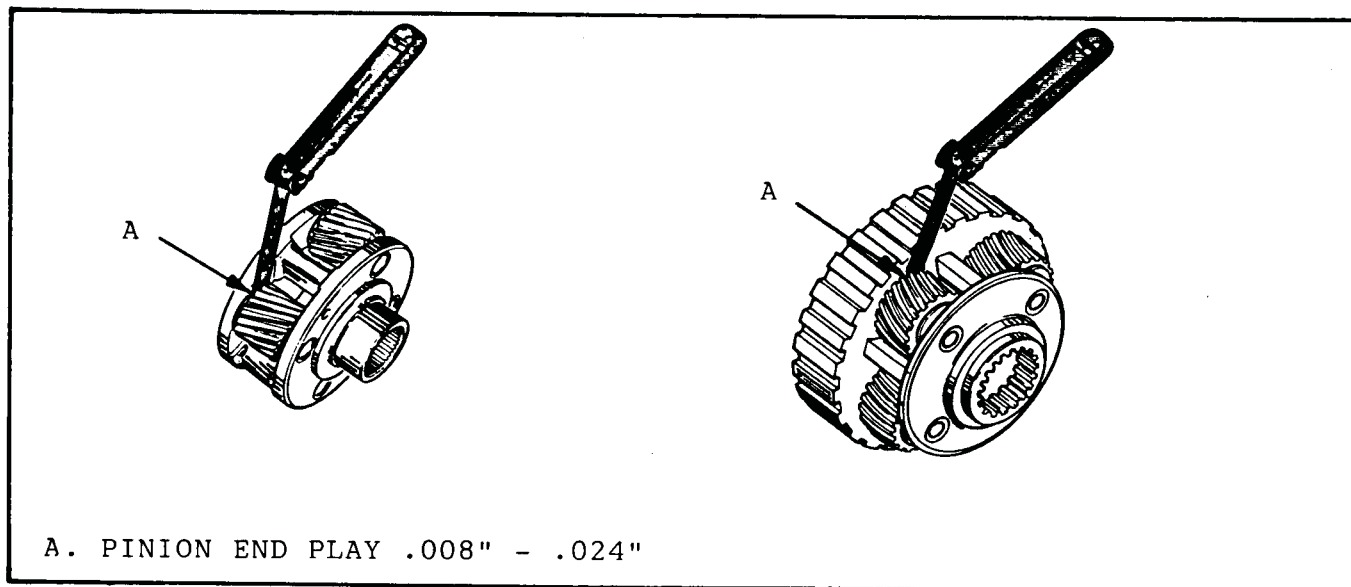

Figure 60

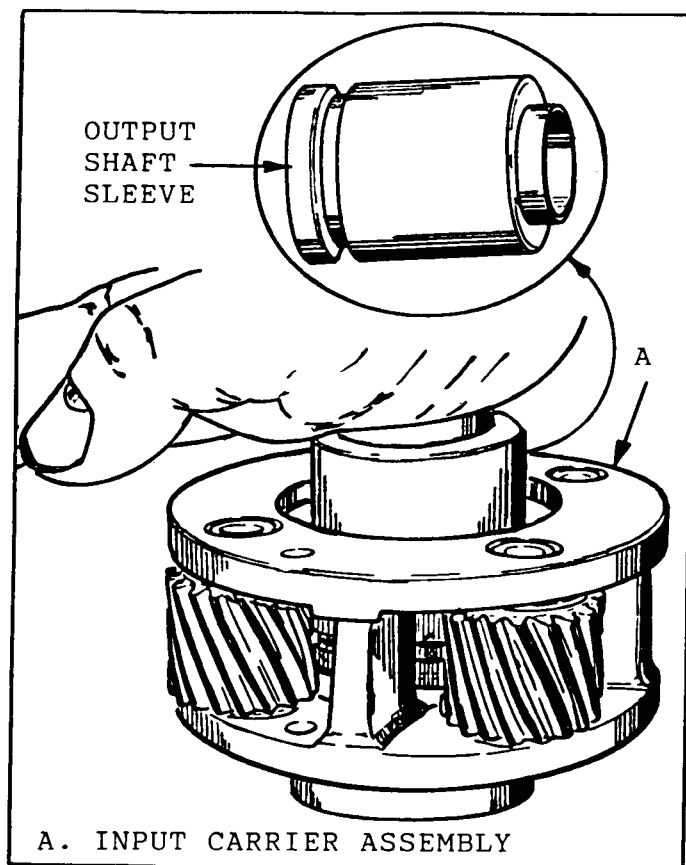

Figure 61

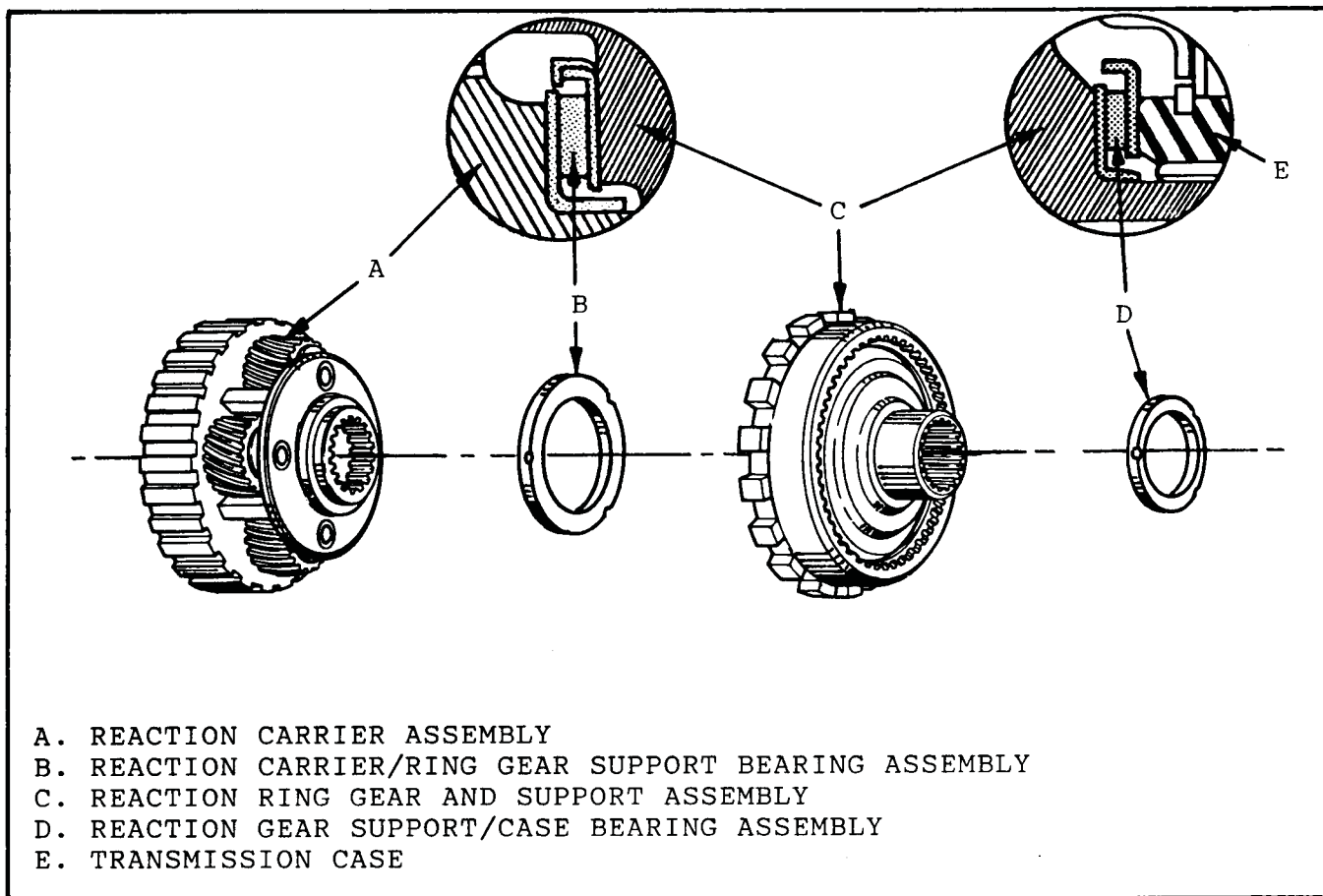

Figure 62

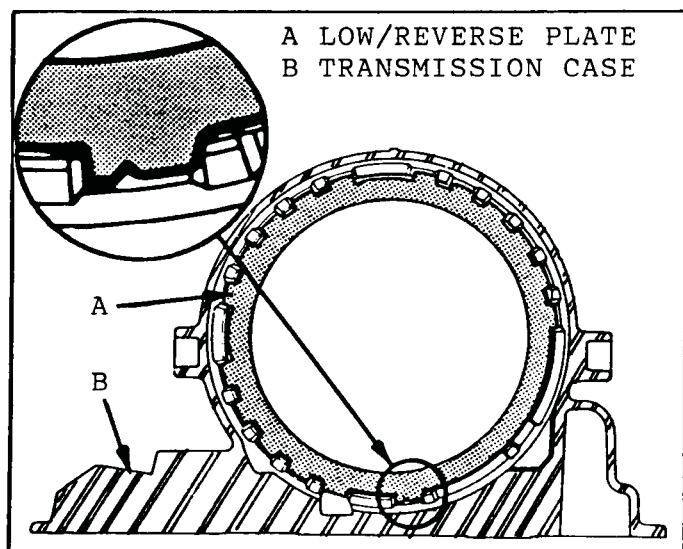

Figure 63

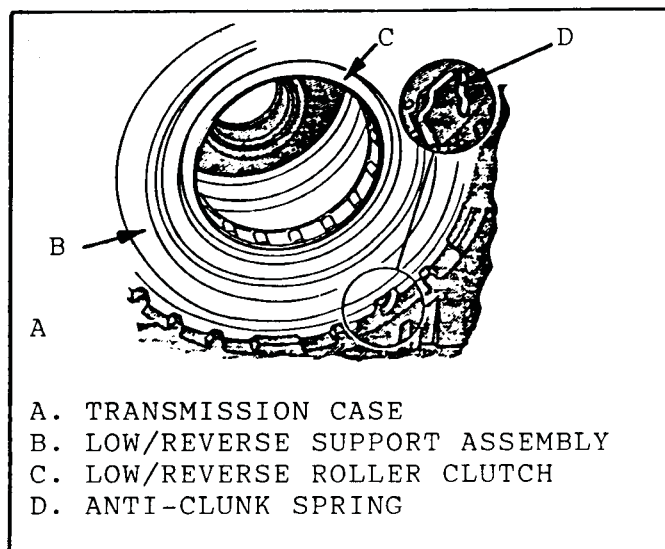

Figure 64

LOW AND REVERSE SUPPORT (Continued)

2. Install roller clutch assembly into the cam and support Assy.
3. Install low and reverse support assembly into the case lugs.
4. Install the L/R support snap ring into the case.
5. Install the low roller inner race into the roller assembly. Rotate inner race as shown in Figure 67, and push down until inner race is engaged on tangs of reaction carrier.
6. Install low roller inner race thrust washer into inner race. Inside tangs of thrust washer should engage in four slots of inner race when properly installed.

REACTION SUN GEAR AND SHELL

1. Inspect the following:
 - *Reaction sun gear for nicked, scored, or worn bushing.
 - *Damaged splines or teeth.
 - *Loose or weak snap ring (This snap ring should never be removed unless replacement is necessary).
 - *Sun gear shell for stripped or worn splines.

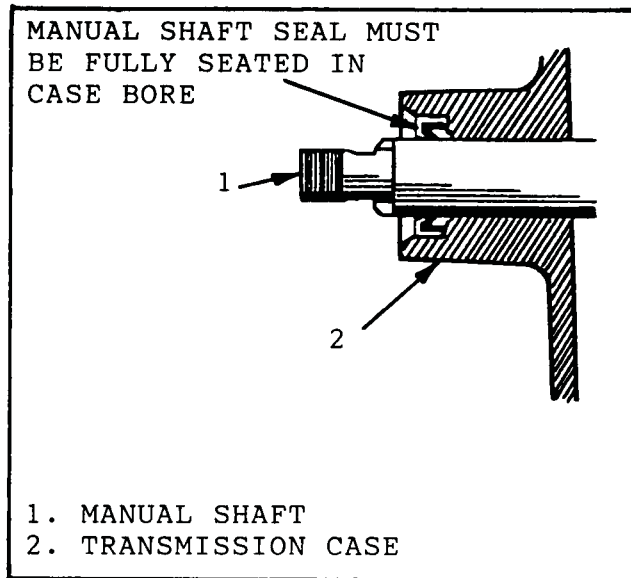
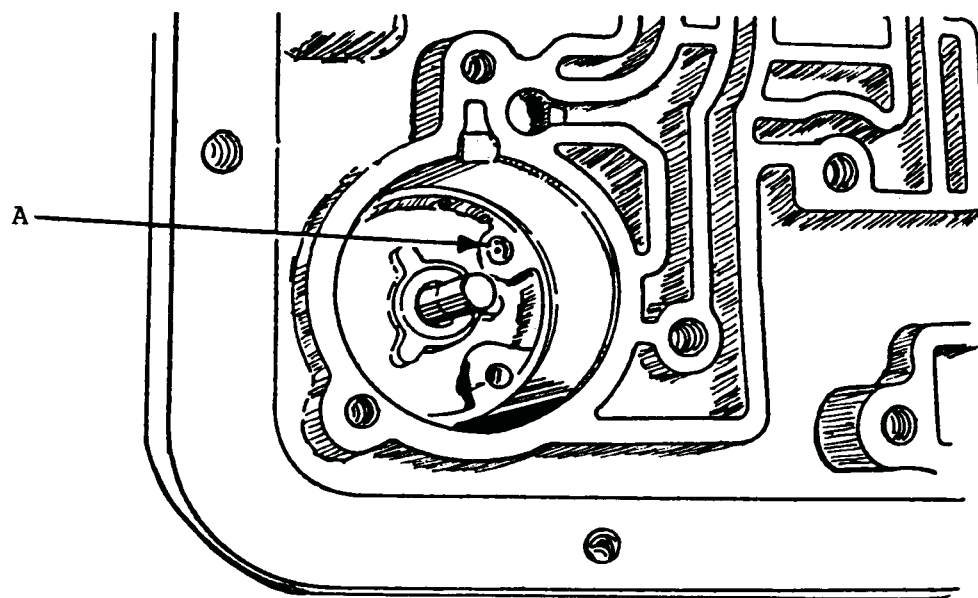

Figure 65



A. 4TH ACCUMULATOR BLEED ORIFICE CUP PLUG

Figure 66

REACTION SUN GEAR AND SHELL (Cont'd)

- *Inspect sun gear shell for broken hub or bent tangs.
- 2. Install reaction sun gear with snap ring on gear.
- 3. Install reaction sun gear shell on splines of reaction sun gear.
- 4. Install sun shell thrust washer with tangs of washer engaged into slots of sun shell, and retain with petrolatum.

- 8. Install black plastic thrust washer on top of input carrier (Retain with petrolatum).
- 9. Install input sun gear into input carrier by turning into place.
- 10. Remove output shaft tool if previously used.
- 11. Refer to Figure 68 for proper assembly of input gear set.

INPUT GEAR SET AND OUTPUT SHAFT

1. Inspect the following:
 - Input ring gear and support for;
 - *Scored, damaged, or worn bushing.
 - *Damaged splines or gear teeth.
 - *Cracked shaft
 - Input carrier to ring gear thrust bearing for wear or damage.
 - Input carrier for;
 - *Pinion gear damage or worn thrust washers. Pinion end play should be .008" - .024". (Figure 60).
 - *Proper pinion pin stake.
 - *Trapped bearing for wear or damage (See Figure 61).
 - Output shaft for;
 - *Plugged or restricted lube oil passages (Air Check).
 - *Damaged splines, or governor drive gear teeth.
 - *Damage or burrs to the front of shaft at lube seal area (Polish with crocus cloth if necessary).
2. Install input ring gear and support, by turning to insure ring gear support splines are engaged into reaction carrier.
3. Install thrust bearing into input ring gear support. Outer race goes toward the reaction carrier as shown in Figure 69.
4. Install input carrier into input ring gear by turning into place.
5. Turn transmission horizontal.
6. Install output shaft into the transmission by turning to index the splines with the mating parts.
7. Install input carrier snap ring onto the output shaft. Use output shaft tool J-29837 if necessary (See Figure 50).

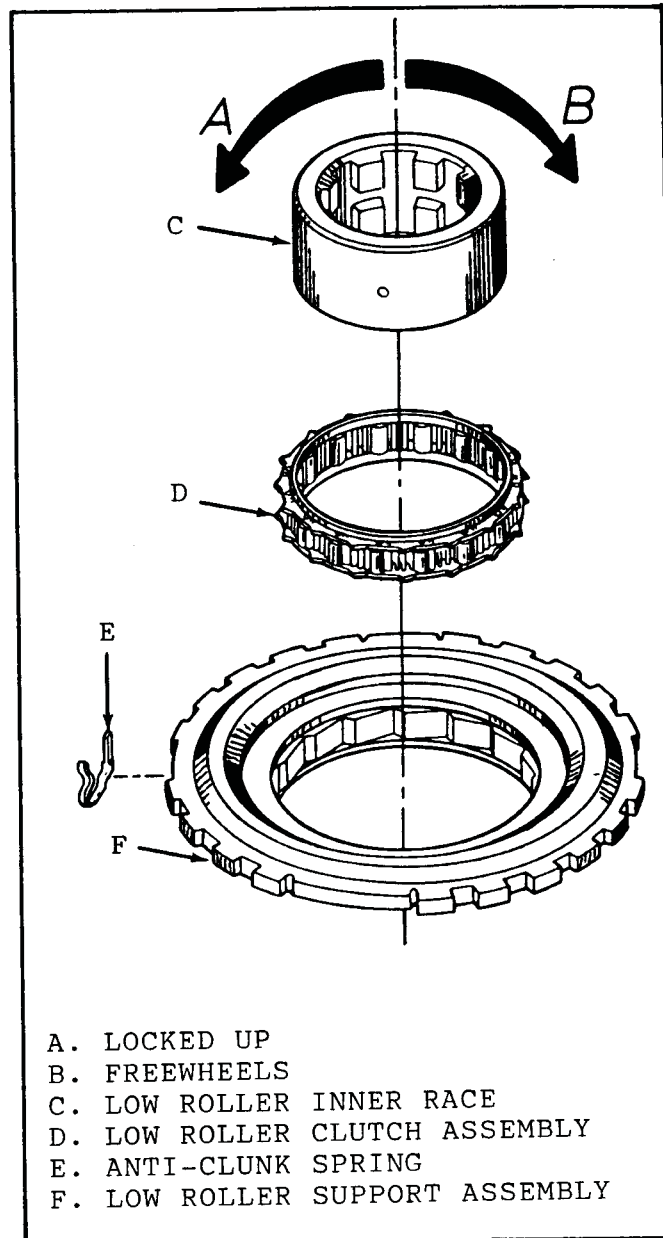
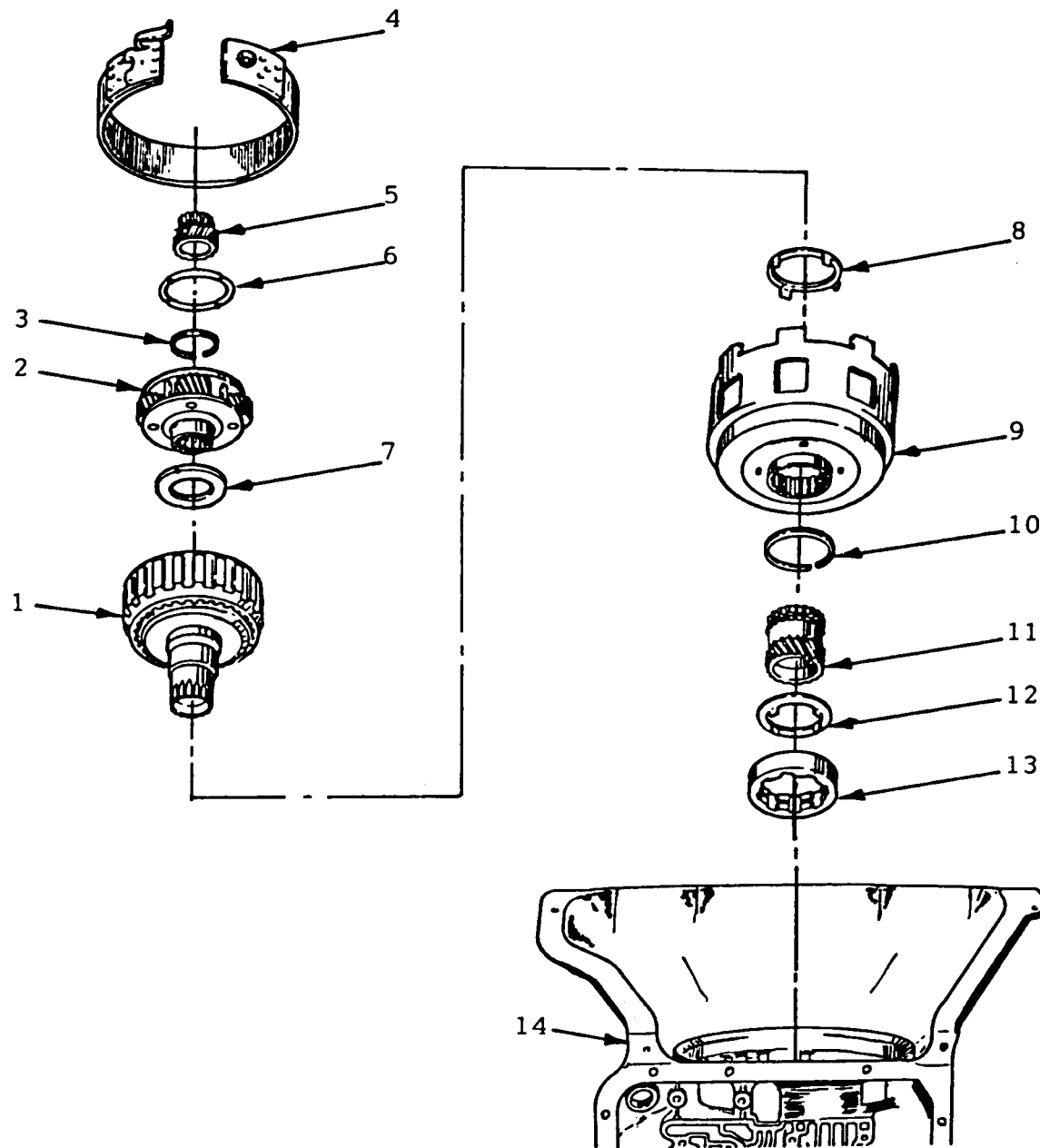

Figure 67



1. INPUT RING GEAR
2. INPUT CARRIER
3. INPUT CARRIER SNAP RING
4. 2-4 BAND ASSEMBLY
5. INPUT SUN GEAR
6. INPUT CARRIER THRUST WASHER
7. INPUT CARRIER BEARING

8. SUN GEAR SHELL/RING GEAR WASHER
9. SUN GEAR SHELL
10. REACTION SUN GEAR SNAP RING
11. REACTION SUN GEAR
12. SUN GEAR/INNER RACE WASHER
13. LOW ROLLER CLUTCH INNER RACE
14. TRANSMISSION CASE

Figure 68

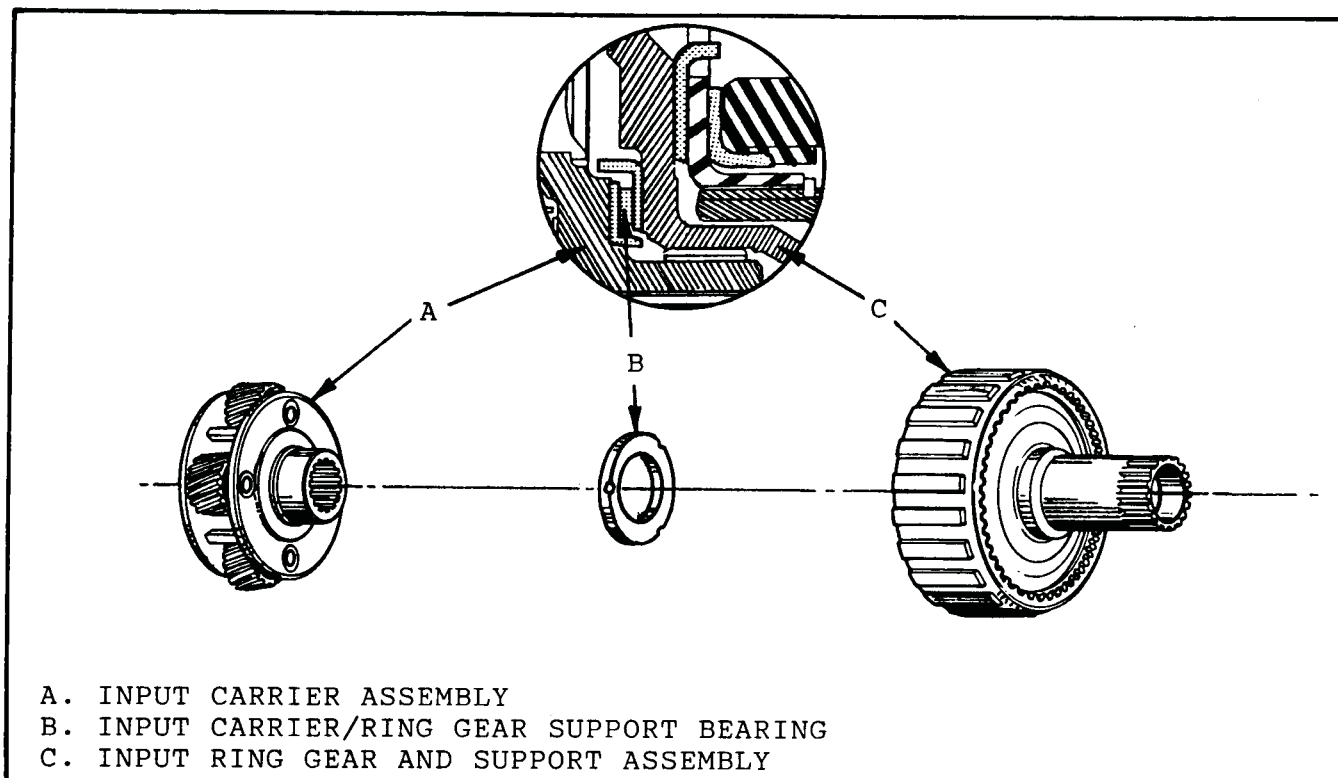
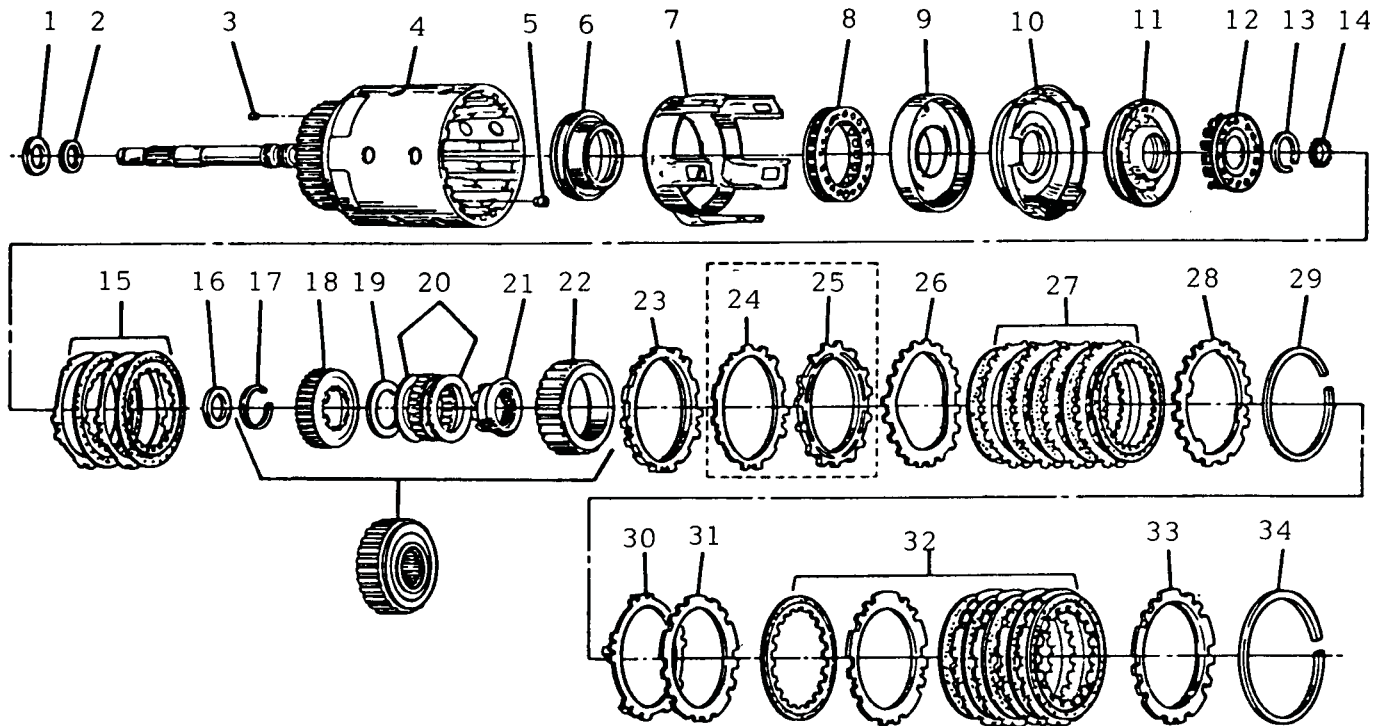

Figure 69

INPUT CLUTCH HOUSING ASSEMBLY

1. Remove the bearing assembly and selective thrust washer from the turbine shaft.
2. Place the input housing assembly on the bench, with the turbine shaft through a hole in the bench.
3. Remove the 3-4 clutch snap ring, and 3-4 backing plate.
4. Remove the 3-4 clutch pack.
5. Remove the 3-4 apply plate.
6. Remove the 3-4 retainer plate.
7. Remove the forward clutch snap ring and forward clutch backing plate.
8. Remove the forward clutch sprag and overrun clutch hub assembly.
9. Remove forward clutch pack.
10. Remove forward clutch wave plate.
11. Remove forward clutch apply plate and spacer plate (If Used).
12. Remove overrun clutch pack.
13. Refer to Figure 70 for disassembly.
14. Install proper spring compressor and compress overrun clutch spring assembly.
15. Remove overrun clutch snap ring.
16. Remove overrun clutch spring assembly.
17. Remove overrun clutch piston and both inner and outer lip seals.
18. Remove forward clutch piston and both inner and outer lip seals.
19. Remove forward clutch housing.
20. Remove 3-4 clutch return spring assembly.
21. Remove 3-4 clutch apply ring.
22. Remove 3-4 clutch piston and both inner and outer lip seals.
23. Remove forward clutch housing to input housing "O" ring seal.
24. Refer to Figure 70 for disassembly.
25. Remove the four (4) turbine shaft oil seal rings from the turbine shaft on the input housing. Always replace them with the solid teflon rings.



- | | |
|--|--|
| 1. INPUT HOUSING BEARING ASSEMBLY | *24. FORWARD CLUTCH APPLY PLATE (THIN) |
| 2. THRUST WASHER (SELECTIVE) | *25. FORWARD CLUTCH SPACER PLATE |
| 3. 3-4 ORIFICED CUP PLUG | 26. FORWARD CLUTCH WAVED PLATE |
| 4. INPUT HOUSING AND SHAFT ASSEMBLY | 27. FORWARD CLUTCH PACK ASSEMBLY |
| 5. 3-4 BALL CAPSULE ASSEMBLY | 28. FORWARD CLUTCH BACKING PLATE |
| 6. 3-4 CLUTCH PISTON | 29. FORWARD CLUTCH SNAP RING |
| 7. 3-4 CLUTCH APPLY RING | 30. 3-4 CLUTCH RETAINER PLATE |
| 8. 3-4 CLUTCH RETURN SPRING ASSY. | 31. 3-4 CLUTCH APPLY PLATE |
| 9. FORWARD CLUTCH HOUSING | 32. 3-4 CLUTCH PACK ASSEMBLY |
| 10. FORWARD CLUTCH PISTON | 33. 3-4 CLUTCH BACKING PLATE |
| 11. OVERRUN CLUTCH PISTON | 34. 3-4 CLUTCH SNAP RING |
| 12. OVERRUN CLUTCH RETURN SPRING | |
| 13. OVERRUN CLUTCH SNAP RING | |
| 14. INPUT HOUSING/OUTPUT SHAFT SEAL | |
| 15. OVERRUN CLUTCH PACK ASSEMBLY | |
| 16. INPUT SUN GEAR BEARING ASSEMBLY | |
| 17. OVERRUN CLUTCH HUB SNAP RING | * USED WITH L-4 AND V-6 ENGINES ONLY |
| 18. OVERRUN CLUTCH HUB | |
| 19. OVERRUN HUB THRUST WASHER | |
| 20. FORWARD SPRAG ASSEMBLY | |
| 21. FORWARD SPRAG INNER RACE | |
| 22. FORWARD SPRAG OUTER RACE | |
| 23. FORWARD CLUTCH APPLY PLATE (THICK)
USED IN V-8 ENGINES ONLY | |

Figure 70

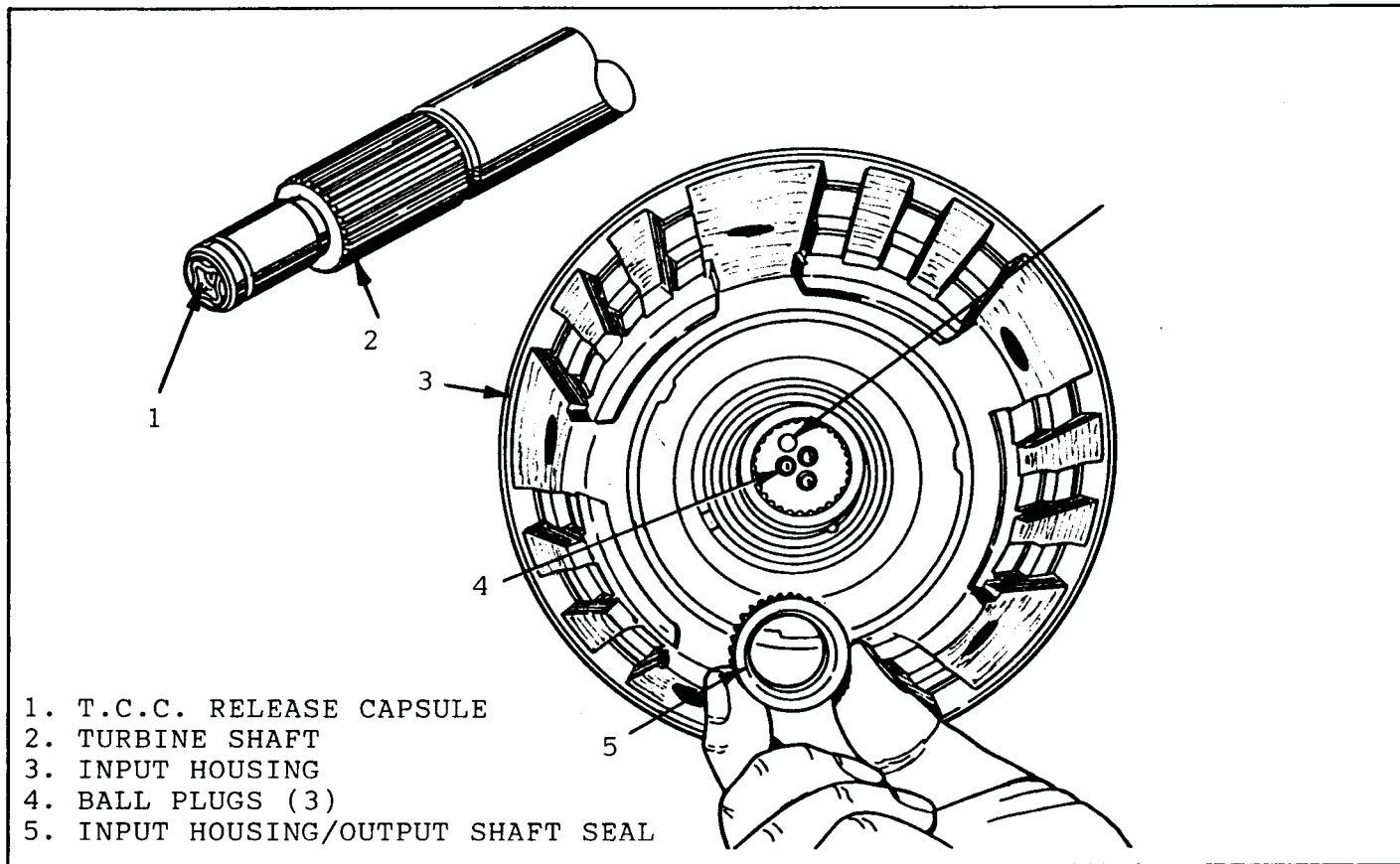

Figure 71

INPUT HOUSING ASSEMBLY

1. Inspect input housing for damage or porosity.
2. Inspect all splines for wear or damage.
3. Air check all feed passages.
4. Inspect the three turbine shaft sealing balls (Figure 71). The balls must not be loose or leaking. The open hole is the lube oil passage which feeds the output shaft (Figure 71).
5. Inspect for presence of orificed cup plug (Figure 72).
6. Check for proper operation of ball capsule assembly (Figure 72).
7. Inspect the turbine shaft ring grooves for damage or cracks.
8. Inspect TCC release capsule for damage (Figure 71). The ball must move freely in the retainer and the retainer must be tight in the turbine shaft.

TCC RELEASE CAPSULE REPLACEMENT PROCEDURES

1. Straighten the tangs of the retainer and remove the ball.
2. Remove the retainer using a #4 screw extractor (Fig. 73).
3. New TCC release capsule Assy.
 * Part number for L-4 and V-6 cylinder is 8647037
 * Part number for V-8 engines is 8639284 (See Figure 74).
4. Install new capsule assembly using a 3/8" drift punch and seat the retainer 1/8" below top surface of the turbine shaft.
5. Be certain that the ball is loose in the retainer.
6. This capsule assembly can be left out on heavy duty applications only, for a firmer T.C.C. apply.

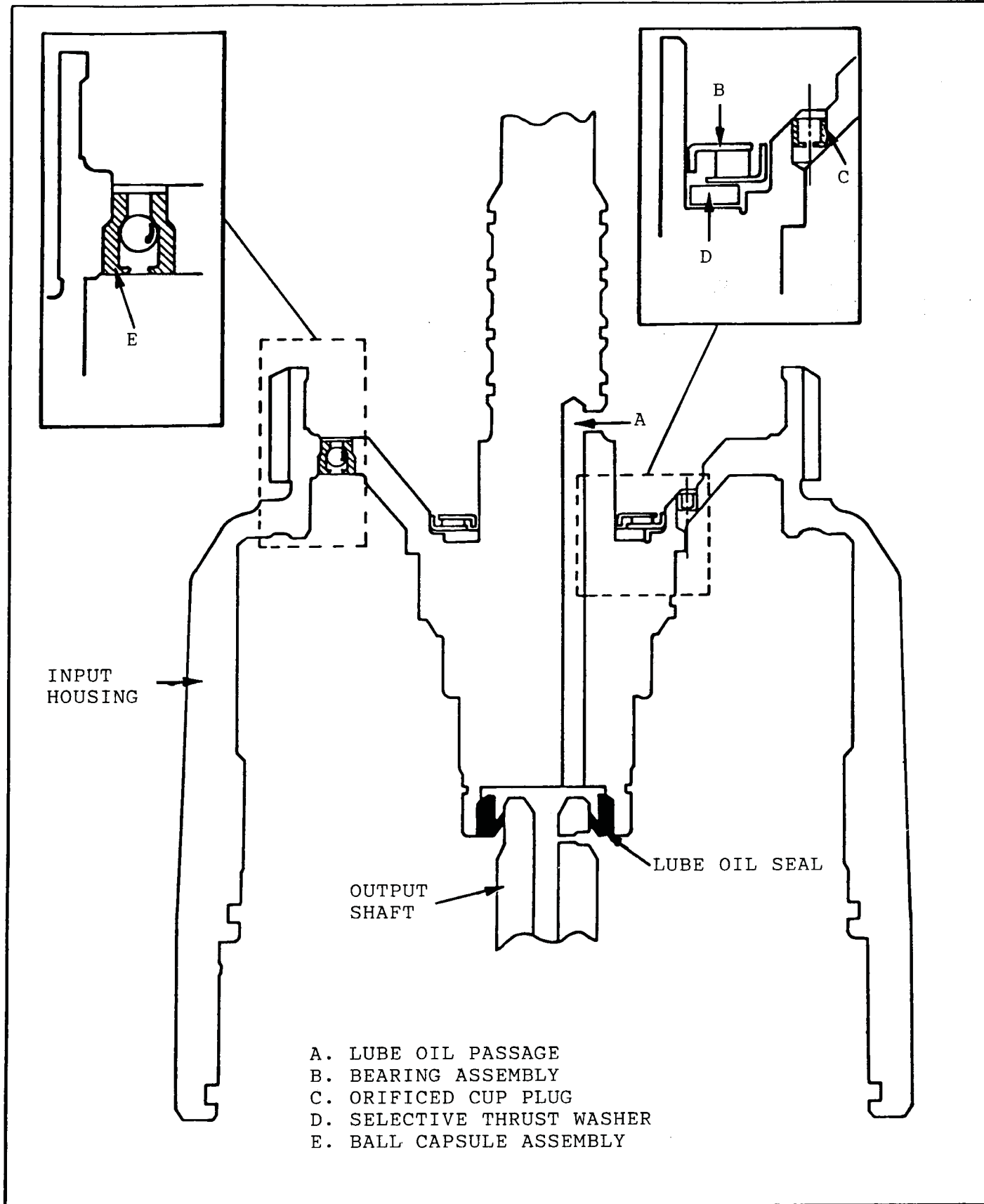

Figure 72



Technical Service Information

INPUT HOUSING ASSEMBLY

1. Inspect the input housing ball capsule assembly, the ball must move freely.
2. Leak check ball capsule with solvent.
3. If replacement is necessary use 1/4" drift punch and hammer to remove and replace capsule.
4. Position the input housing on the bench with the turbine shaft through a hole in the bench.
5. Inspect the 3-4 clutch piston for damage or cracks.
6. Inspect the 3-4 clutch apply ring for bent legs, and for proper length of legs (See Figure 76).
7. Inspect the 3-4 clutch return spring assembly for damage or distortion.
8. Install the inner and outer 3-4 clutch lip seals on the 3-4 clutch piston. Seal lips must face the direction shown in Figure 77.
9. Lubricate the seals with petrolatum, and install the 3-4 clutch piston into the input housing as shown in Figure 77.

INPUT HOUSING ASSEMBLY (FORWARD PISTON)

1. Inspect forward clutch housing for proper check ball operation, damage or distortion, burrs in seal areas, and for cracks.

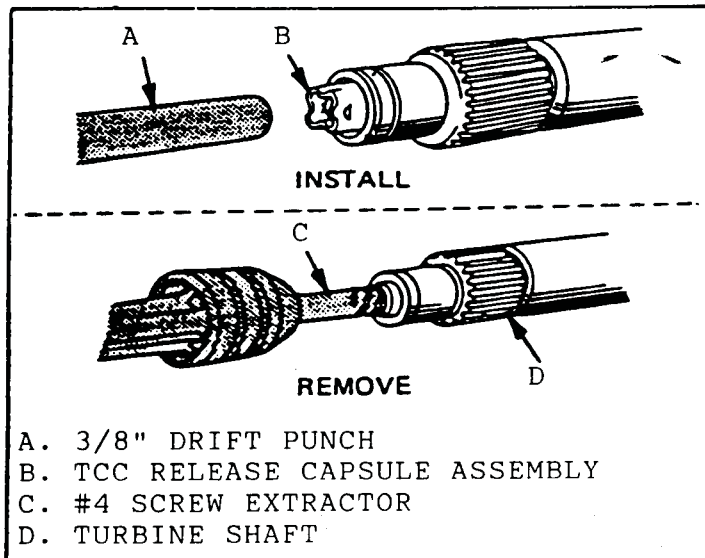

Figure 73

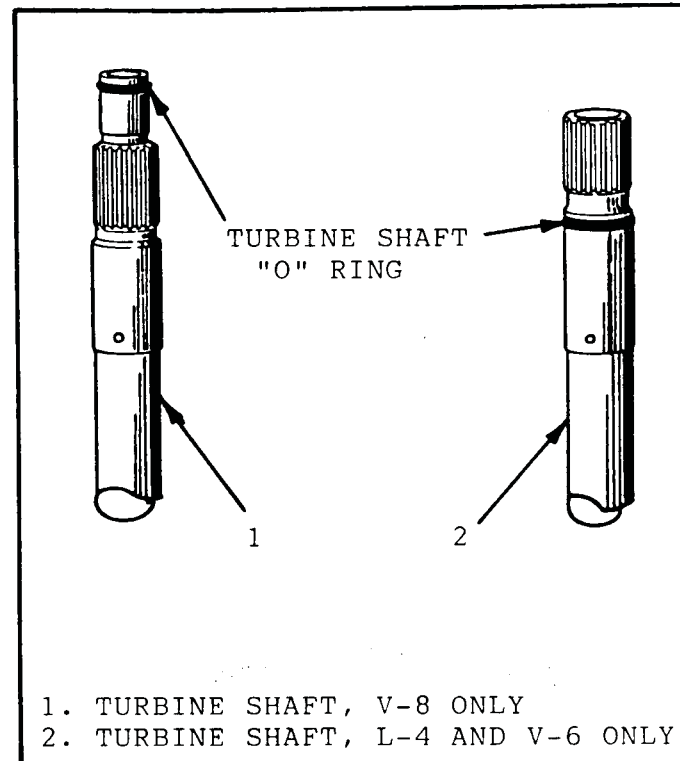
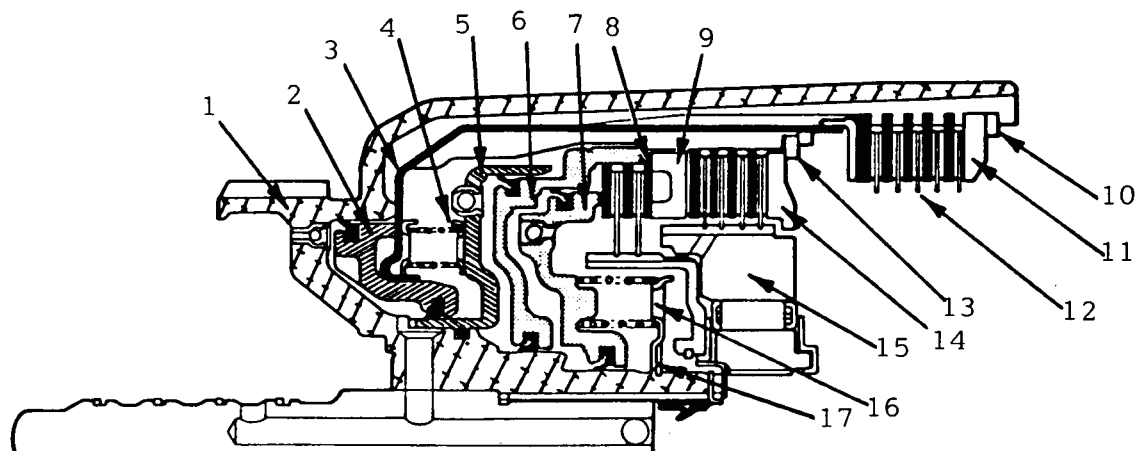

Figure 74

2. Install new "O" ring into input housing groove as shown in Figure 77.
3. Use Figures 70, 75, 77, 78 for the assembly process.
4. Install the 3-4 clutch apply ring on top of the 3-4 clutch piston.
5. Install the 3-4 clutch spring assembly on top of the 3-4 clutch apply ring (See Figure 77).
6. Install the forward clutch housing into the input housing as shown in Figure 77.
7. Inspect the forward clutch piston for damage or cracks.
8. Install the inner and outer lip seals on the forward clutch piston as shown in Figure 77.
9. Install forward clutch piston into forward clutch housing using tool J-29883 as shown in Figure 77.
NOTE: The forward clutch apply legs must be indexed with the 3-4 clutch apply ring legs.
10. Firmly seat the assembly.
11. Install tool J-29882 as shown in Figure 78.
12. Inspect overrun clutch piston for damage or cracks.



- | | |
|---|----------------------------------|
| 1. INPUT HOUSING | 11. 3-4 CLUTCH BACKING PLATE |
| 2. 3-4 CLUTCH PISTON | 12. 3-4 CLUTCH PACK |
| 3. 3-4 CLUTCH APPLY RING | 13. FORWARD CLUTCH SNAP RING |
| 4. 3-4 RETURN SPRING ASSEMBLY | 14. FORWARD CLUTCH BACKING PLATE |
| 5. FORWARD CLUTCH HOUSING | 15. FORWARD SPRAG ASSEMBLY |
| 6. FORWARD CLUTCH PISTON | 16. OVERRUN RETURN SPRING ASM. |
| 7. OVERRUN CLUTCH PISTON | 17. OVERRUN CLUTCH SNAP RING |
| 8. FORWARD CLUTCH APPLY PLATE, (V8 MODELS THICK - L4 & V6 THIN) | |
| 9. FORWARD CLUTCH SPACER (L4 & V6 ONLY) | |
| 10. 3-4 CLUTCH SNAP RING | |

Figure 75

INPUT HOUSING ASSEMBLY (Cont'd)

13. Install the inner and outer lip seals on the overrun clutch piston, as shown in Figure 78.
14. Install the overrun clutch piston over J-29882, with hub facing upward as shown in Figure 78.

NOTE: If all parts are properly seated to this point, the overrun piston hub will be approximately 3/16" below the snap ring groove in the input housing hub.

15. Install overrun clutch spring assembly onto the overrun piston, locating the springs on the piston tabs.
16. Install spring compressor and compress spring assembly, and install overrun clutch snap ring.

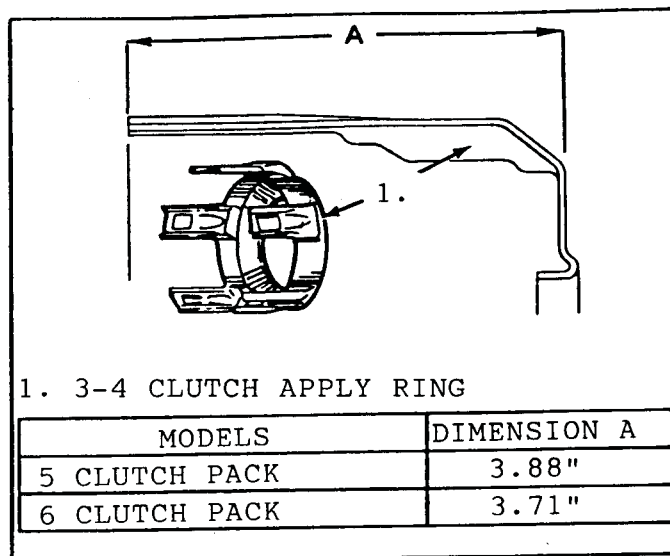
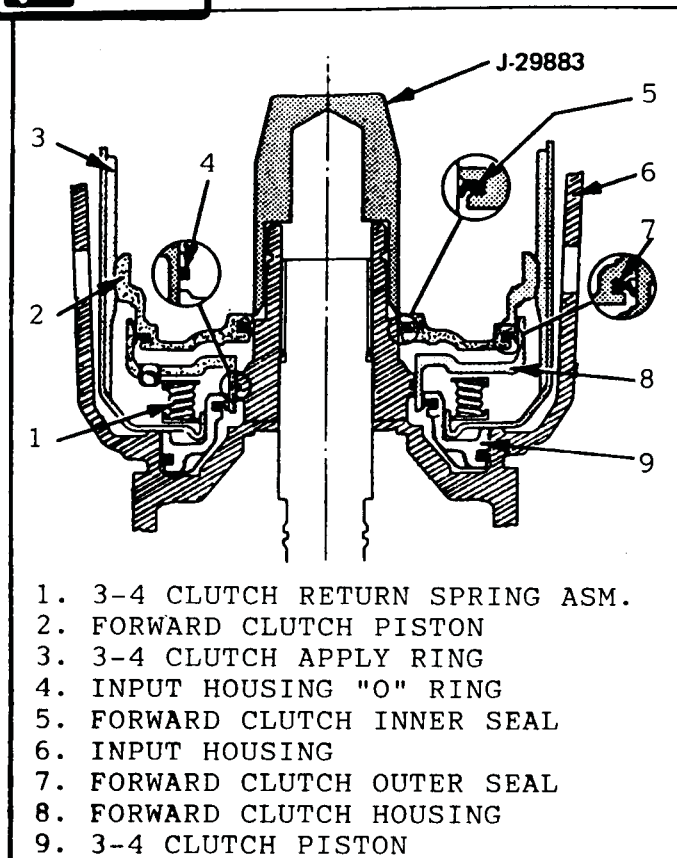

Figure 76



1. 3-4 CLUTCH RETURN SPRING ASM.
2. FORWARD CLUTCH PISTON
3. 3-4 CLUTCH APPLY RING
4. INPUT HOUSING "O" RING
5. FORWARD CLUTCH INNER SEAL
6. INPUT HOUSING
7. FORWARD CLUTCH OUTER SEAL
8. FORWARD CLUTCH HOUSING
9. 3-4 CLUTCH PISTON

Figure 77

FORWARD CLUTCH SPRAG ASSEMBLY

1. Disassemble forward clutch sprag assembly and inspect following;
 - * Forward sprag for wear or damage, or broken ribbon tabs.
 - * Overrun clutch hub for spline damage, or plugged lube holes.
 - * Inner and outer sprag race for wear or damage, surface finish for wear or damage, and for spline damage.
2. Install forward sprag assembly into outer race from the side opposite the recess (See Figure 83).
3. The notches in the sprag assembly cage must face upward as shown in Figure 83.
4. Install the inner race into the sprag assembly. Insert the race by pushing in and turning to the left as shown in Figure 84.
5. Install remaining wear plate.
6. Install thrust washer.
7. Install overrun clutch hub, and overrun hub snap ring (Figure 82).

ASSEMBLE OVERRUN CLUTCH PLATES

1. Install the overrun clutch plates into the input housing.
2. The overrun clutch plates are the smallest of the three sets of plates in the input housing.
3. The overrun clutch requires 2 steel plates, and 2 lined plates. Start the pack with a steel plate and alternate with lined plate, as shown in Figure 79.
4. The overrun clutch steel plates must be indexed into the input housing, and requires ONLY two lined and two steel.
5. Install input housing lube oil seal into input housing as shown in Figure 71.
6. Install thrust bearing assembly into input housing as shown in Figure 81.
7. Retain bearing assembly with petrolatum.

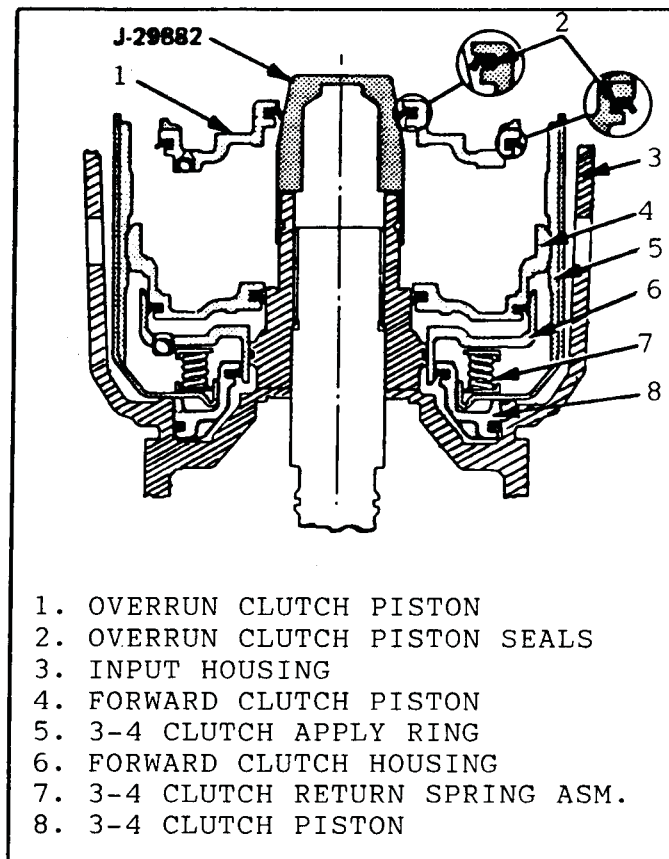

1. OVERRUN CLUTCH PISTON
2. OVERRUN CLUTCH PISTON SEALS
3. INPUT HOUSING
4. FORWARD CLUTCH PISTON
5. 3-4 CLUTCH APPLY RING
6. FORWARD CLUTCH HOUSING
7. 3-4 CLUTCH RETURN SPRING ASM.
8. 3-4 CLUTCH PISTON

Figure 78

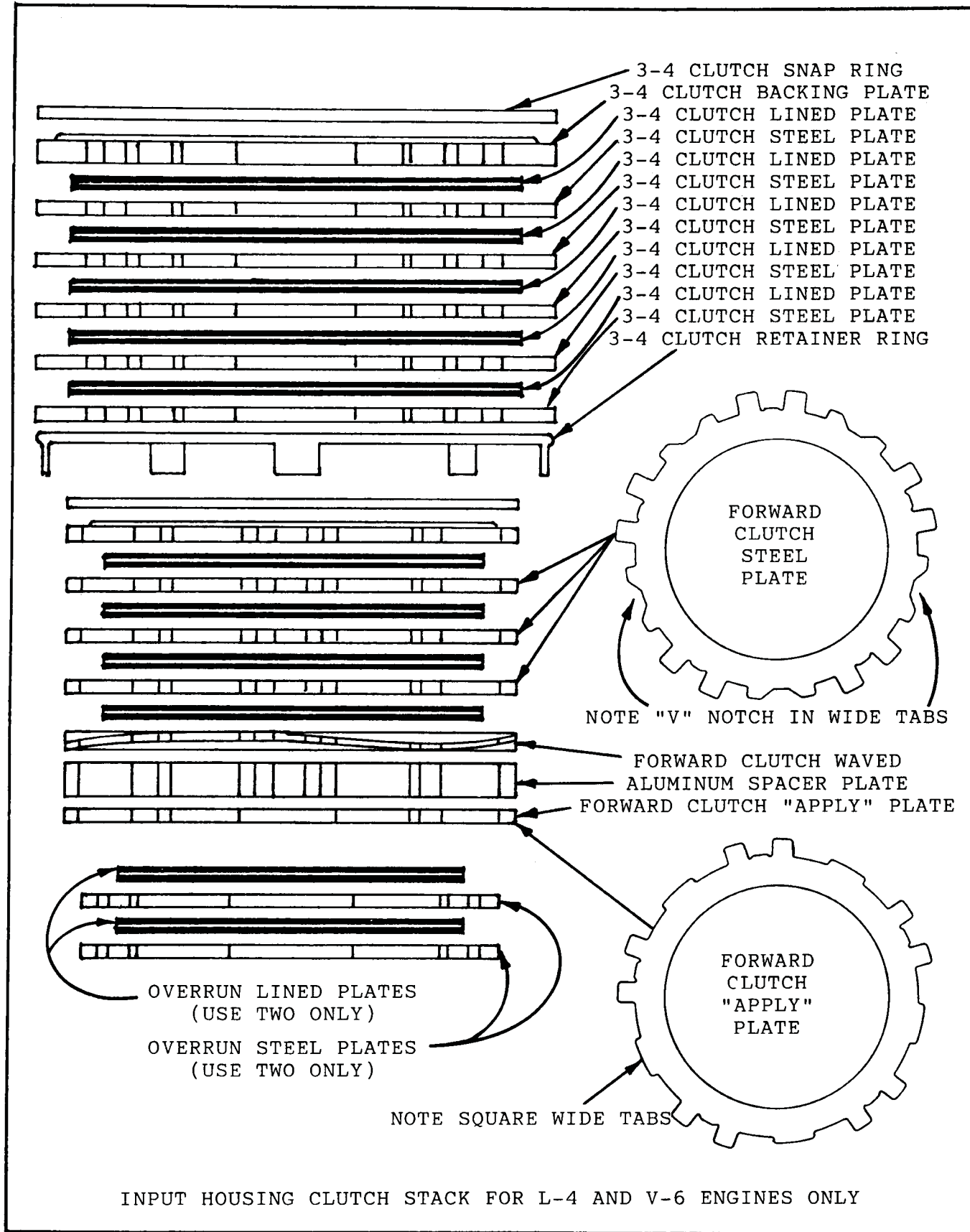

Figure 79

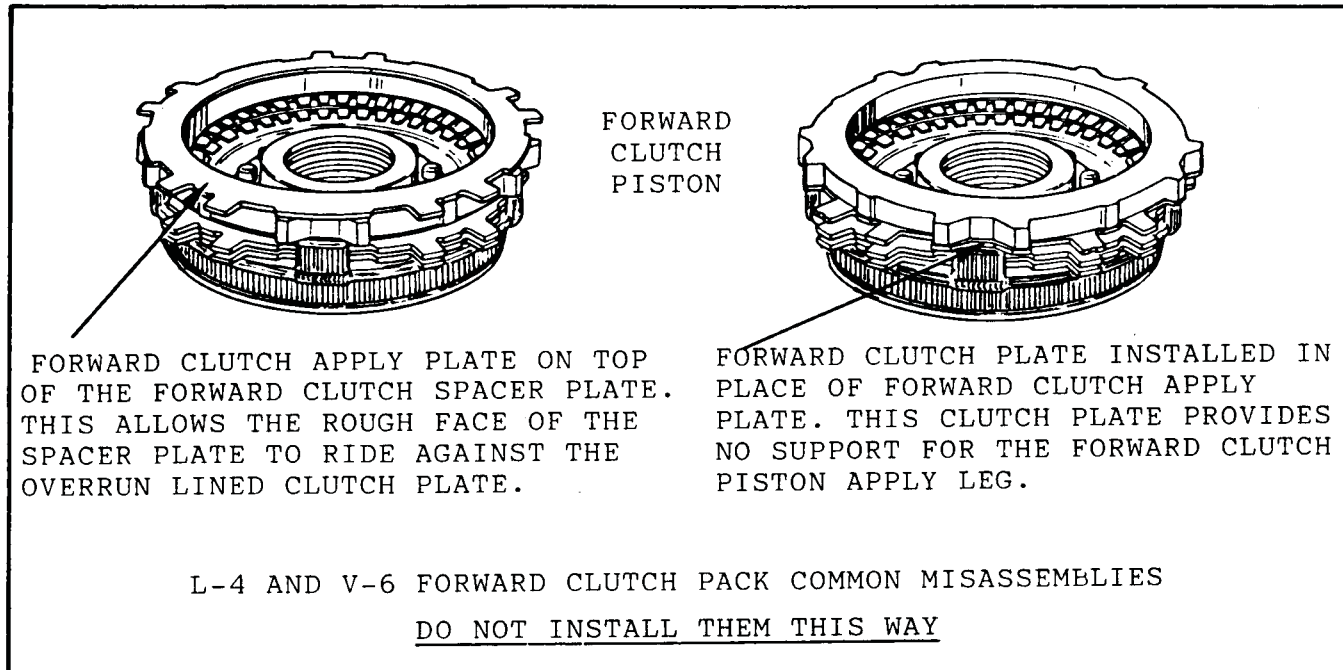

Figure 80

ASSEMBLE FORWARD CLUTCH PLATES

1. Test the forward sprag assembly for proper operation as shown in Figure 85.
2. Install forward sprag assembly into the input housing by turning, and indexing the overrun clutch hub into the overrun clutch plates.
3. Install appropriate forward clutch apply plate by indexing into input housing.
NOTE: A forward clutch which requires 5 lined plates will use a single thick apply plate. A forward clutch which requires 4 lined plates will use a thin apply plate and an aluminum spacer plate (See Figure 79).
4. Install spacer plate into input housing (if required). Proper assembly here is very important (See Figures 79 and 80).
5. Install forward clutch waved steel plate.
6. Install the remaining forward clutch plates into the input housing, alternating with lined and steel.
7. Install forward clutch backing plate and snap ring.

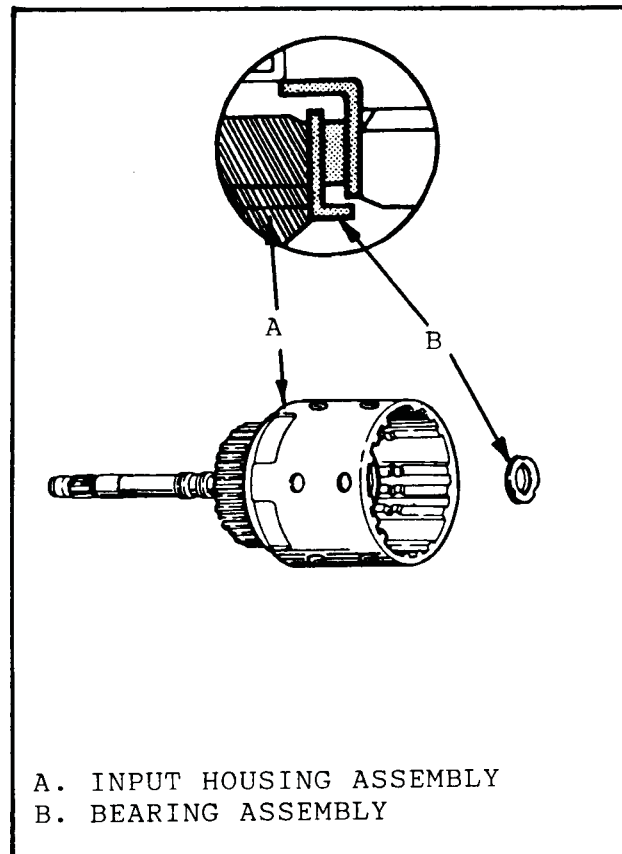

Figure 81

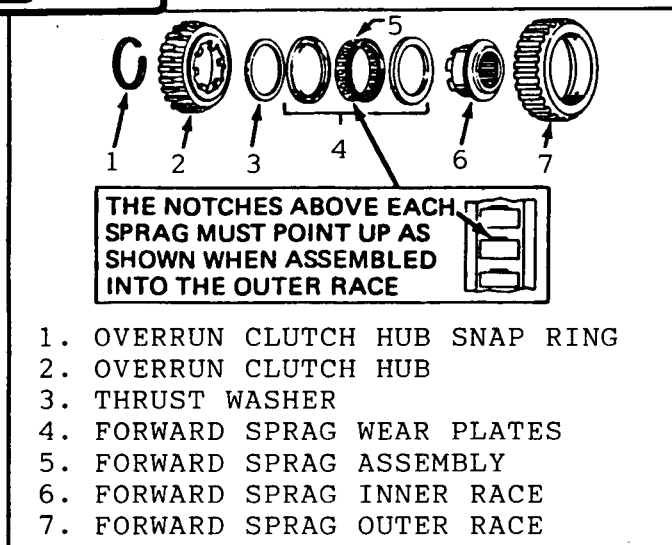

Figure 82

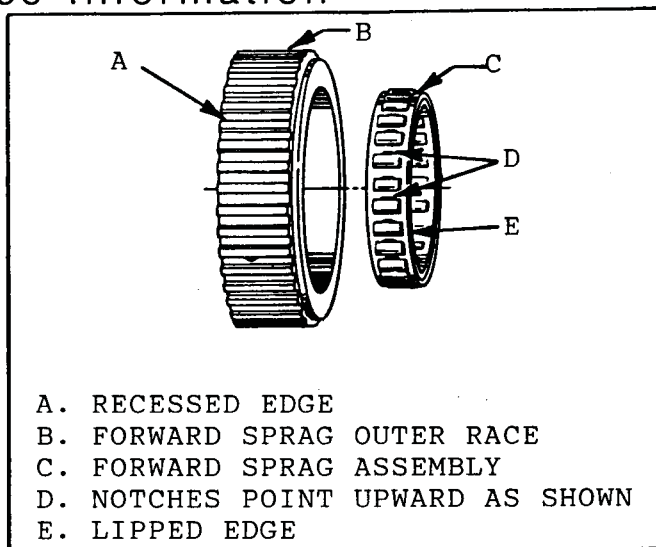

Figure 83

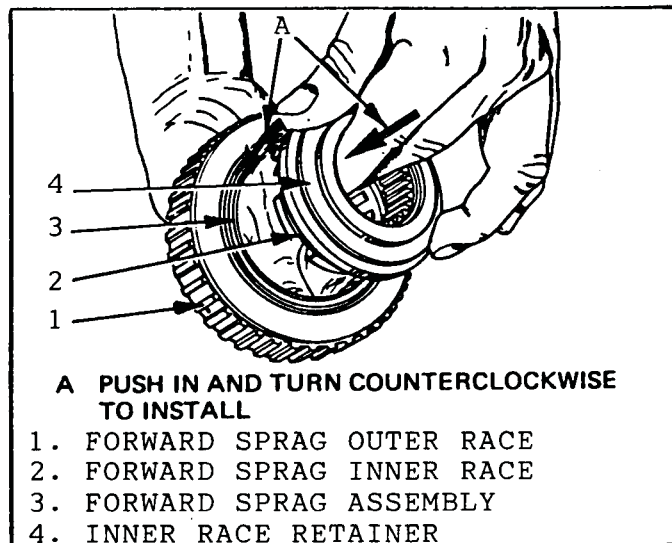

Figure 84

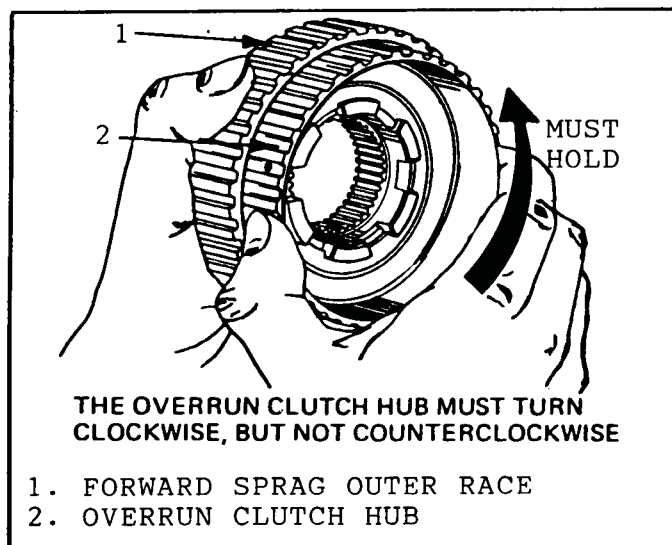

Figure 85

ASSEMBLE FORWARD CLUTCH PLATES (Cont'd)

- Use information chart in Figure 86 to determine thickness and amount of clutch plates to use.

ASSEMBLE 3-4 CLUTCH PLATES

- Install the 3-4 clutch retainer ring (Figure 87). Be sure that each tab on the retainer is on the outside of the legs of the 3-4 clutch piston. This retainer is used to keep the legs of the 3-4 clutch piston from spreading under load.
- Install 3-4 clutch apply plate.
- Install the 3-4 clutch plates, alternating lined and steel until you finish with a lined.
- Use information chart in Figure 88 to determine thickness and amount of clutch plates to use.
- Install the 3-4 clutch backing plate.
- Install the 3-4 clutch snap ring.
- Check the clutch clearance with a feeler gage, between the backing plate and the first lined plate.
- Select the proper backing plate from the chart in Figure 89, to obtain the correct clearance.
- Air check the 3-4, forward, and overrun clutches by applying air pressure at the feed holes in the turbine shaft. When the overrun clutch is checked, air will exit the forward clutch feed hole in the turbine shaft.

FORWARD CLUTCH INFORMATION CHART			
PLATE TYPE	THICKNESS	QUANTITY REQUIRED	
		*A-MODELS	*B-MODELS
FLAT STEEL CLUTCH PLATE	(.090")	3	4
COMPOSITION FACED CLUTCH PLATES	(.070")	4	5
APPLY PLATE (THICK)	(.251")	0	1
APPLY PLATE (THIN)	(.077")	1	0
SPACER PLATE	(.330")	1	0
WAVED STEEL CLUTCH PLATE	(.079")	1	1

*A-MODELS	L-4 AND V-6 ENGINES		
*B-MODELS	V-8 ENGINES		

Figure 86

SEALING RING INSTALLATION

1. Set input housing on bench with turbine shaft up.
2. Install the four (4) turbine shaft sealing rings onto the turbine shaft beginning with the bottom ring.
3. Solid Teflon sealing rings are recommended in this position.
4. Solid rings will require an installation tool, and resizing tool (See Figure 90).
5. Install selective thrust washer onto input housing.
6. Install input housing thrust bearing assembly onto the input housing as shown in Figure 70.
7. Set completed input housing aside until final assembly.

NOTE: It would be best to leave resizing tool installed on the input housing sealing rings until ready for final assembly. This will ensure no damage during pump installation.

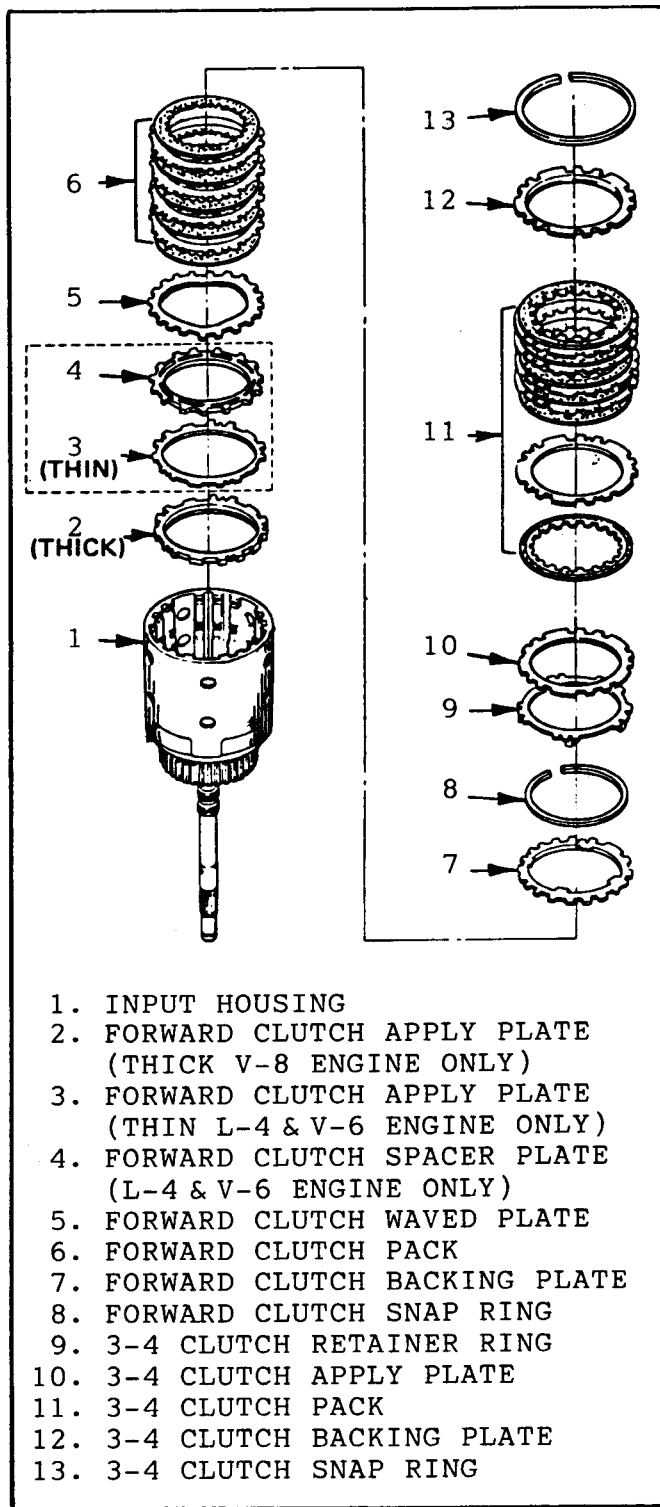

Figure 87

3-4 CLUTCH INFORMATION CHART			
PLATE TYPE	THICKNESS	QUANTITY REQUIRED	
		*A-MODELS	*B-MODELS
FLAT STEEL CLUTCH PLATE	(.077")	4	5
COMPOSITION FACED CLUTCH PLATES	(.079")	5	6
APPLY PLATE	(.130")	1	1
BACKING PLATE	SELEC-TIVE	1	1
*A-MODELS	FIVE CLUTCH PACK		
*B-MODELS	SIX CLUTCH PACK		

Figure 88

DISASSEMBLE REVERSE INPUT CLUTCH

1. Use Figure 91 for disassembly.
2. Remove the snap ring from the reverse input housing.
3. Remove reverse input backing plate.
4. Remove reverse input clutches.
5. Remove reverse input clutch waved plate.
6. Install appropriate spring compressor, and compress reverse input return spring assembly.
7. Remove return spring snap ring.
8. Remove spring compressor and reverse input return spring assembly.
9. Remove reverse input piston assembly, and remove inner and outer lip seals from piston.

INSPECT THE FOLLOWING:

1. Backing plate for distortion or damage, and surface finish for any damage.
2. Steel clutch plates for tang damage, wear, or heat damage.
3. Return spring assembly for distortion or damage.
4. Piston for dishing or distortion, and seal retaining rings for looseness.

3-4 BACKING PLATE SELECTION			
MODEL	BACKING PLATE TRAVEL	*BACKING PLATE	
		Use Backing Plate Which Gives Correct Travel	
		DIM.	I.D.
FIVE CLUTCH MODELS	(.055" - .109")	(.278")	1
		(.239")	2
SIX CLUTCH MODELS	(.049" - .113")	(.200")	3
		(.161")	4

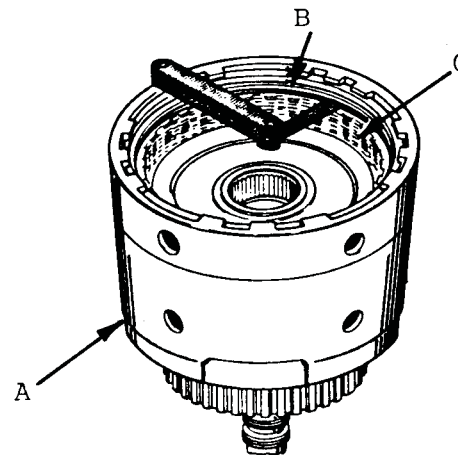

- A. INPUT HOUSING ASSEMBLY
 B. 3-4 CLUTCH BACKING PLATE
 C. 3-4 CLUTCH PACK

Figure 89

5. Housing assembly for damaged or worn bushings, surface finish where the band rides and for dishing (See Figure 94), check ball assembly for free movement (leak check with solvent), and for leak at the weld.

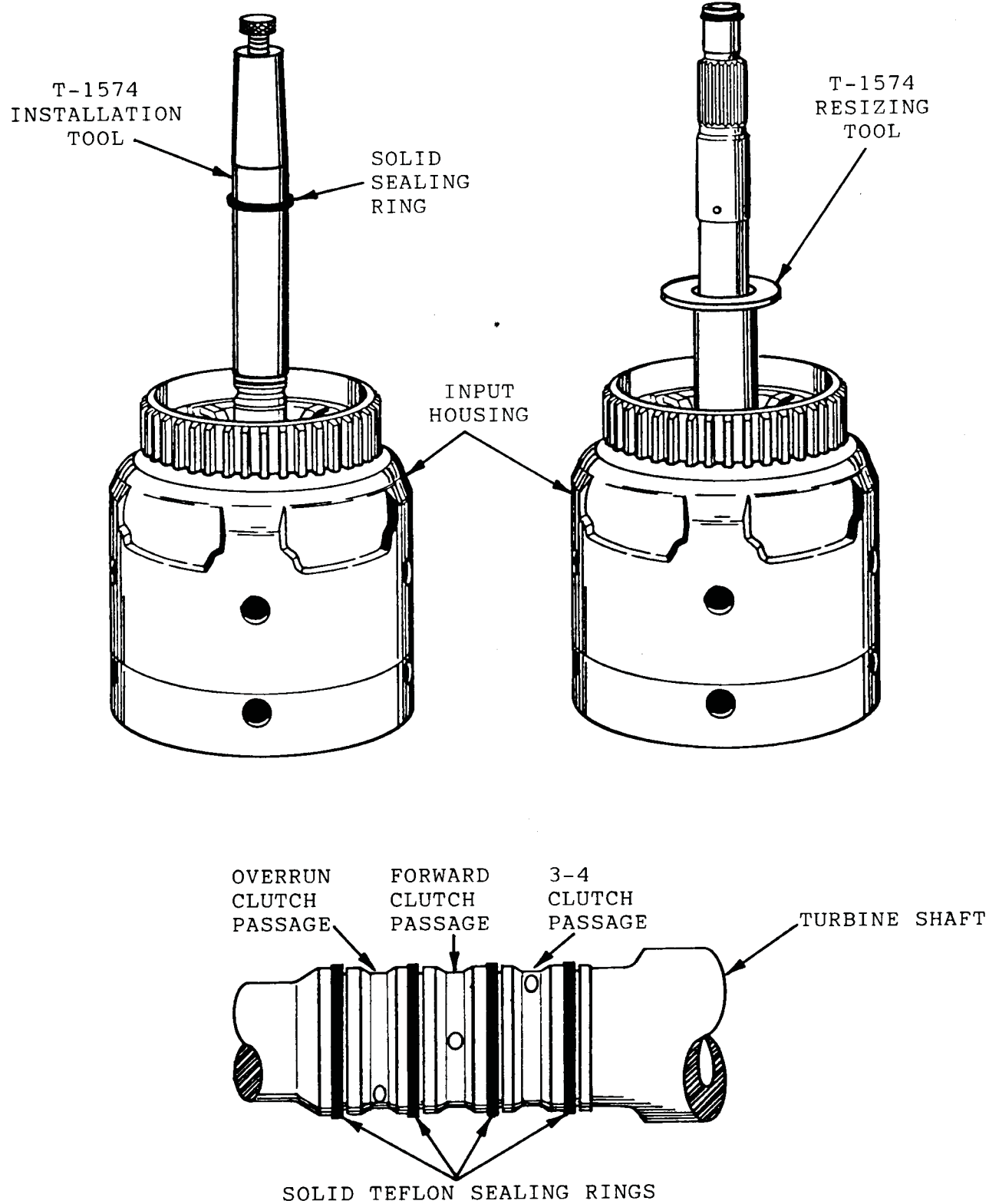
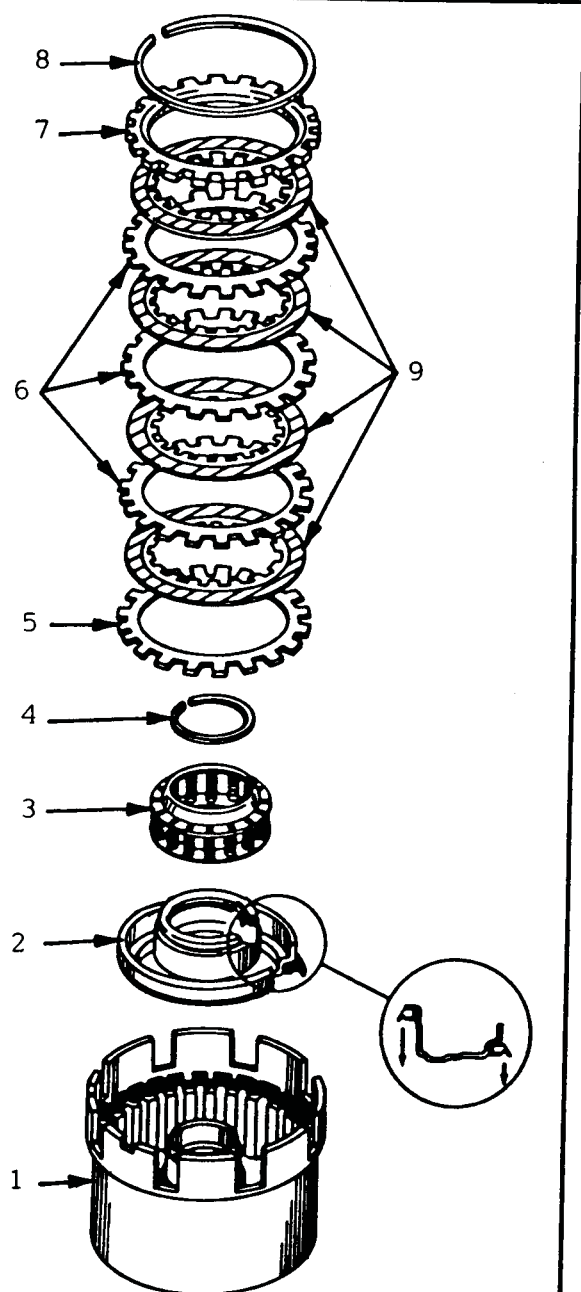

Figure 90



1. REVERSE INPUT HOUSING
2. REVERSE INPUT PISTON
3. REVERSE INPUT RETURN SPRING
4. RETURN SPRING SNAP RING
5. REVERSE INPUT WAVED PLATE
6. REVERSE INPUT STEEL PLATES
7. REVERSE INPUT BACKING PLATE
8. REVERSE INPUT SNAP RING
9. REVERSE INPUT LINED PLATES

Figure 91

REVERSE INPUT CLUTCH						
MODEL	FLAT STEEL		COMP. FACED		WAVED STEEL	
	No.	Thick-ness	No.	Thick-ness	No.	Thick-ness
L-4 & V-6 ENGINES	2	(.077")	3	(.079")	1	(.079")
V-8 ENGINES	3	(.077")	4	(.079")	1	(.079")

Figure 92

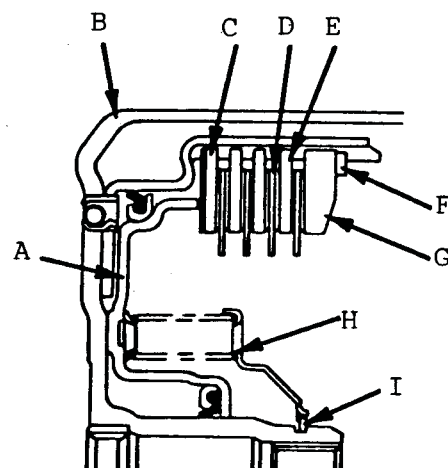

- A. REVERSE INPUT PISTON
- B. REVERSE INPUT HOUSING
- C. REVERSE INPUT WAVED PLATE
- D. REVERSE INPUT LINED PLATE
- E. REVERSE INPUT STEEL PLATE
- F. REVERSE INPUT SNAP RING
- G. REVERSE INPUT BACKING PLATE
- H. REVERSE INPUT RETURN SPRING
- I. RETURN SPRING SNAP RING

Figure 93

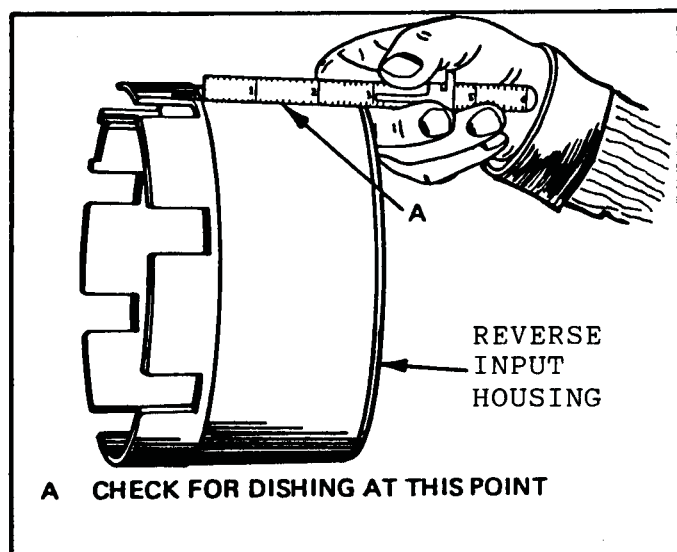

Figure 94

ASSEMBLE REVERSE INPUT HOUSING

1. Install inner and outer lip seals onto reverse input piston.
2. Lip seals must face away from the spring side of the piston as shown in Figure 91.
3. Lubricate seals with petrolatum.
4. Install piston assembly into the reverse input housing, using care not to damage the seals.
5. Install return spring assembly on top of the piston.
6. Install appropriate spring compressor, compress return spring, and install return spring snap ring.
7. Remove spring compressor.
8. Install reverse input clutch waved steel plate.
9. Install reverse input clutches, starting with a lined plate on top of the waved, and alternating with steel plates.
10. See chart in Figure 92 for proper number of clutch plates.
11. Install reverse input backing plate, chamfered side up.
12. Install reverse input clutch snap ring into drum.
13. Air check reverse input housing assembly, to verify no damage was done to seals during the assembly process.

ASSEMBLE REVERSE INPUT CLUTCH AND INPUT CLUTCH HOUSINGS

1. Make sure that your selective washer and bearing assembly have been installed properly onto the input housing. Refer to Figure 72 for proper assembly.
2. Bearing assembly should be installed with the black race towards the oil pump.
3. Install reverse input housing onto the input clutch housing.
4. Rotate and index the reverse input clutch plates onto the hub of the input housing.
5. Make certain that all clutches are fully engaged.
6. Install reverse input and input clutch assembly into the transmission case.
7. There will be three items to index properly during installation.
 - * 3-4 clutch plates must be indexed on the input ring gear.
 - * Input sun gear must be indexed into the forward sprag inner race.
 - * Reverse input housing must be indexed into the sun gear shell
8. Great care must be exercised to ensure that all clutch plates are fully seated.
9. When properly assembled, the reverse input clutch housing will be located just below the case oil pump face.

2-4 BAND ASSEMBLY

1. Inspect the 2-4 band assembly for wear or damage.
2. Install the 2-4 band assembly into the transmission case.
3. Install the band anchor pin into the case (See Figure 95).
4. Index the 2-4 band onto the band anchor pin.
5. Anchor pin will be just below valve body surface when properly installed.

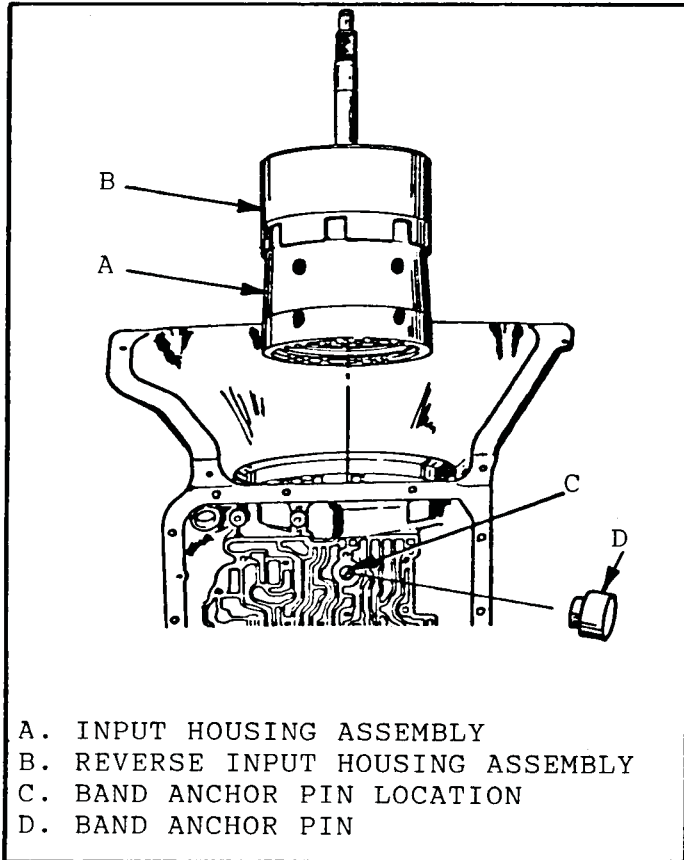

Figure 95

OIL PUMP DISASSEMBLE

1. Remove oil pump thrust washer.
2. Remove pump cover to case gasket.
3. Remove pump body to case "O" ring seal.
4. Remove five pump cover bolts.
5. Remove pump cover from pump body.
6. Remove pump slide springs by prying out with screwdriver.
CAUTION: Springs are under very high tension. Place covering over spring to prevent possible injury.
7. Remove pump rotor, rotor guide, vane rings, and all vanes.
8. Remove slide pivot pin, pivot pin spring.
9. Remove pump slide from oil pump pocket.
10. Discard slide seal, seal support, slide seal back-up "O" ring.
11. Remove oil pump converter seal.

12. Remove oil pump bushing with a proper size bushing driver.
13. Remove the converter clutch apply valve train by pushing valve stop down with a screw driver, and removing snap ring with snap ring pliers.
14. Slowly release the spring tension.
15. Remove valve stop, TCC apply valve, and 2 converter clutch valve springs.
16. Remove the pressure regulator assembly by pushing bushing down with a screwdriver, and removing snap ring with snap ring pliers.
17. Slowly release the spring tension.
18. Remove TV boost valve and bushing, reverse boost valve and bushing, pressure regulator spring, and pressure regulator valve.
19. Refer to Figure 96 for disassembly process.

ROTOR AND/OR SLIDE REPLACEMENT

1. A one inch micrometer capable of measuring in tenths will be required to accurately measure the pump slide and rotor.
2. Refer to the chart in Figure 97 for proper rotor and slide selection.

IMPORTANT!

Measurement of rotor and slide must be made on undamaged surfaces. Select exact size replacements. Lightly hone both sides of replacement rotor or slide to remove any nicks.

Proper selection of rotor and slide sizes are very important on this transmission.

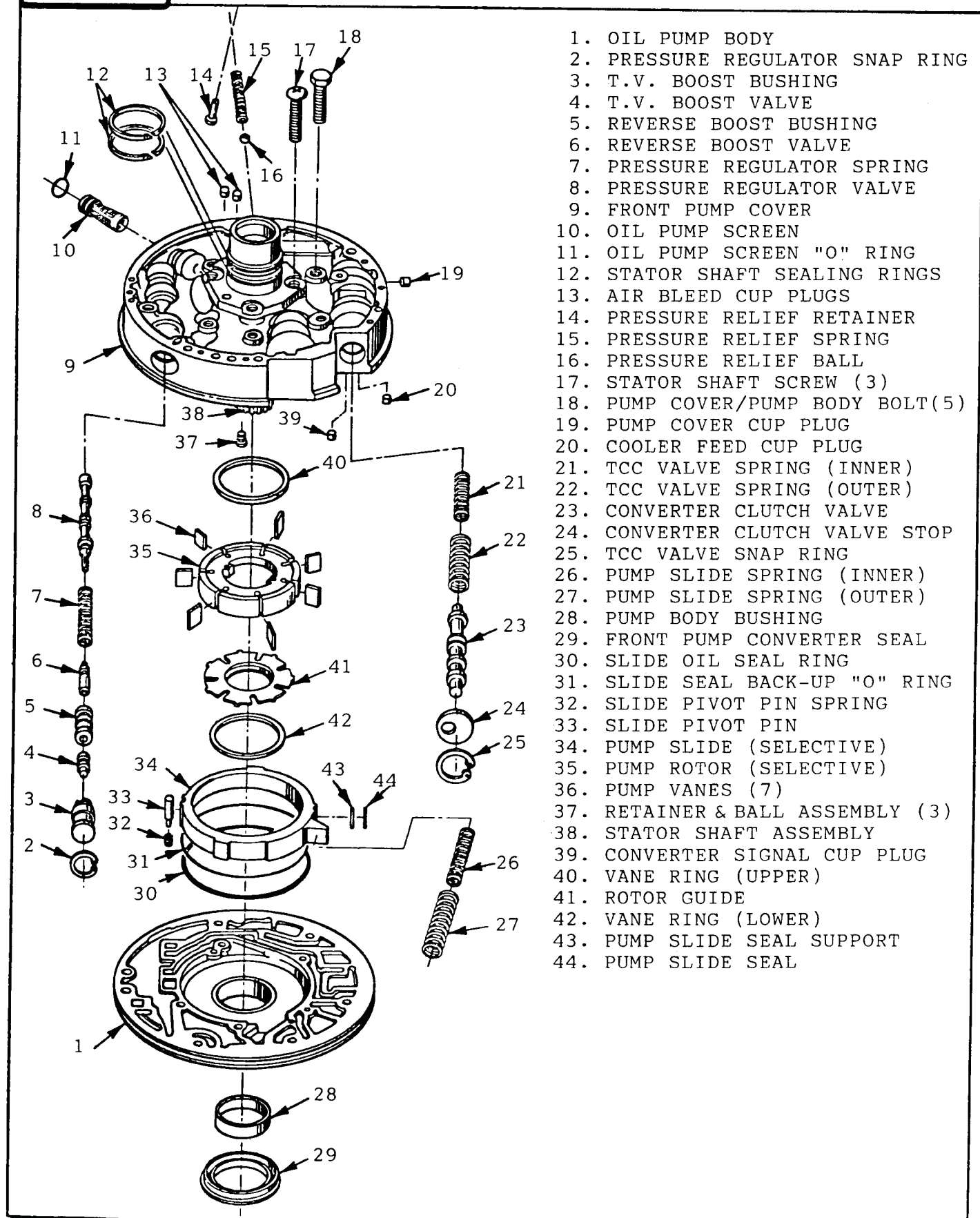

1. OIL PUMP BODY
2. PRESSURE REGULATOR SNAP RING
3. T.V. BOOST BUSHING
4. T.V. BOOST VALVE
5. REVERSE BOOST BUSHING
6. REVERSE BOOST VALVE
7. PRESSURE REGULATOR SPRING
8. PRESSURE REGULATOR VALVE
9. FRONT PUMP COVER
10. OIL PUMP SCREEN
11. OIL PUMP SCREEN "O" RING
12. STATOR SHAFT SEALING RINGS
13. AIR BLEED CUP PLUGS
14. PRESSURE RELIEF RETAINER
15. PRESSURE RELIEF SPRING
16. PRESSURE RELIEF BALL
17. STATOR SHAFT SCREW (3)
18. PUMP COVER/PUMP BODY BOLT(5)
19. PUMP COVER CUP PLUG
20. COOLER FEED CUP PLUG
21. TCC VALVE SPRING (INNER)
22. TCC VALVE SPRING (OUTER)
23. CONVERTER CLUTCH VALVE
24. CONVERTER CLUTCH VALVE STOP
25. TCC VALVE SNAP RING
26. PUMP SLIDE SPRING (INNER)
27. PUMP SLIDE SPRING (OUTER)
28. PUMP BODY BUSHING
29. FRONT PUMP CONVERTER SEAL
30. SLIDE OIL SEAL RING
31. SLIDE SEAL BACK-UP "O" RING
32. SLIDE PIVOT PIN SPRING
33. SLIDE PIVOT PIN
34. PUMP SLIDE (SELECTIVE)
35. PUMP ROTOR (SELECTIVE)
36. PUMP VANES (7)
37. RETAINER & BALL ASSEMBLY (3)
38. STATOR SHAFT ASSEMBLY
39. CONVERTER SIGNAL CUP PLUG
40. VANE RING (UPPER)
41. ROTOR GUIDE
42. VANE RING (LOWER)
43. PUMP SLIDE SEAL SUPPORT
44. PUMP SLIDE SEAL

Figure 96

AUTOMATIC TRANSMISSION SERVICE GROUP

OIL PUMP ROTOR SELECTION CHART	
THICKNESS (mm)	THICKNESS (in.)
17.948 - 17.961	0.7066 - 0.7071
17.961 - 17.974	0.7071 - 0.7076
17.974 - 17.987	0.7076 - 0.7081
17.987 - 18.000	0.7081 - 0.7086
18.000 - 18.013	0.7086 - 0.7091

OIL PUMP SLIDE SELECTION CHART	
THICKNESS (mm)	THICKNESS (in.)
17.948 - 17.961	0.7066 - 0.7071
17.961 - 17.974	0.7071 - 0.7076
17.974 - 17.987	0.7076 - 0.7081
17.987 - 18.000	0.7081 - 0.7086
18.000 - 18.013	0.7086 - 0.7091

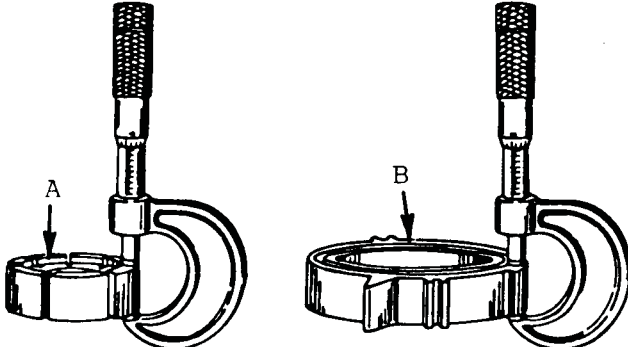

A. OIL PUMP ROTOR
B. OIL PUMP SLIDE

Figure 97

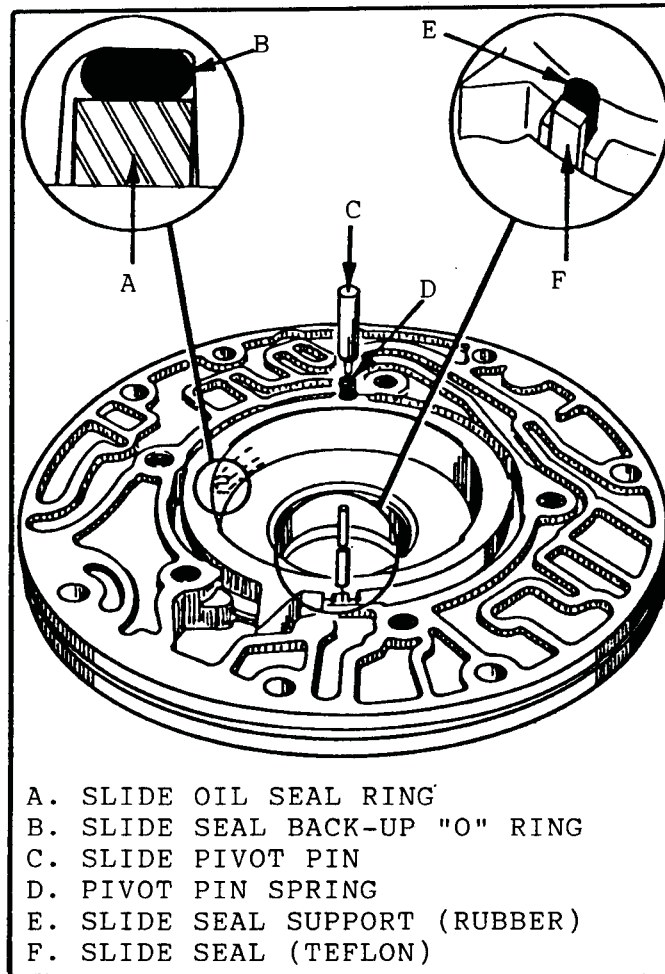

Figure 98

ASSEMBLE PUMP BODY AND PUMP COVER

1. Install new pump body bushing into pump body (if necessary).
2. Staking bushing to keep it from moving toward seal is recommended.
3. Install front pump seal, and seal retainer part #8654491.
4. Install "O" ring back-up and oil seal ring into the groove on the back side of the pump slide. Retain with petrolatum. (See Figure 98)
5. Install slide seal support and Teflon slide seal onto pump slide, and retain with petrolatum (See Figure 98).
6. Install pump slide assembly into pump body pocket being careful not to disturb slide seals.
7. Pull pump slide straight towards the slide seal with one hand, and with the other hand install pivot pin and spring.
8. Insure that pump slide moves back and forth freely in the pump pocket.
9. Install both pump slide springs.
10. Install rotor guide onto pump rotor, and retain with petrolatum.
11. Install vane ring into pump pocket.
12. Install pump rotor and guide assembly into pump pocket with guide towards the pump pocket.
13. Install vanes into pump rotor.
14. Install remaining vane ring into pump rotor.
15. Align and install oil pump cover onto oil pump body.
16. Install five pump cover to body bolts, but do not tighten.
17. Install alignment tool J-21368 onto oil pump assembly as shown in Figure 102.
18. Torque attaching bolts to 18 ft. lbs.

19. Install inner and outer converter clutch valve springs into the pump cover, into the converter clutch valve bore. (See Figure 96).
20. Install converter clutch valve into the same bore, with the valve installed as shown in Figure 99.
21. Install converter clutch valve stop, push down with screw driver, and install snap ring.
22. Grind two "Flats" on the second land of the pressure regulator valve as shown in Figure 101.
23. Make sure you use a pressure regulator valve that is cross-drilled as shown in Figure 101. The crossdrilled valve is available under OEM #8637546.
24. Install modified pressure regulator valve into pressure regulator valve bore in the pump cover (See Figure 96).
25. Insure that valve moves freely in the bore.
26. Install pressure regulator valve spring into the same bore.
27. Install reverse boost valve into the reverse boost valve bushing "Exactly" as shown in Figure 99, and retain with petrolatum.
28. Install reverse boost assembly into PRV bore on top of spring as shown in Figure 99.
29. Install T.V. boost valve into T.V. boost valve bushing "Exactly" as shown in Figure 99, and retain with petrolatum.
30. Install T.V. boost assembly into PRV bore on top of reverse boost assembly as shown in Figure 99.
31. Push assembly down with small screwdriver, and install snap ring.

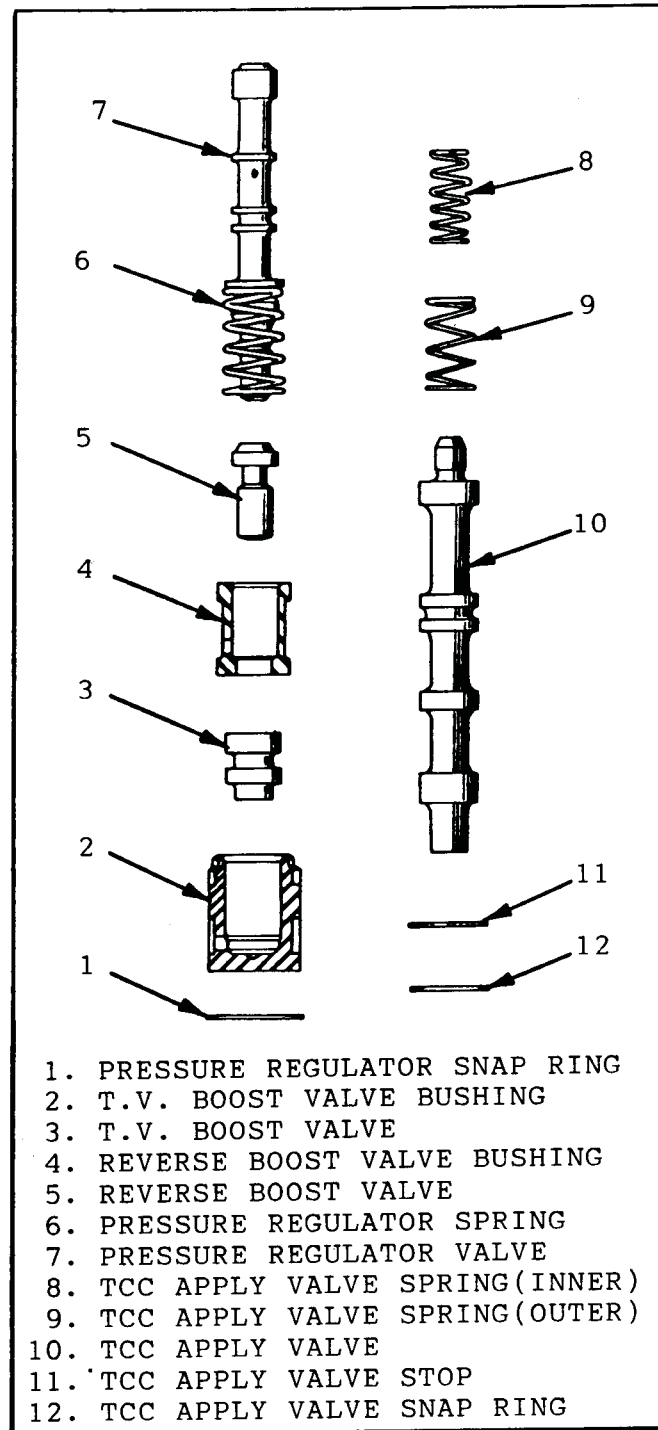

Figure 99

NOTE: Pressure regulator valve train, and converter clutch valve train, MUST be installed "EXACTLY" as shown in Figure 99, or damage to the transmission could result.

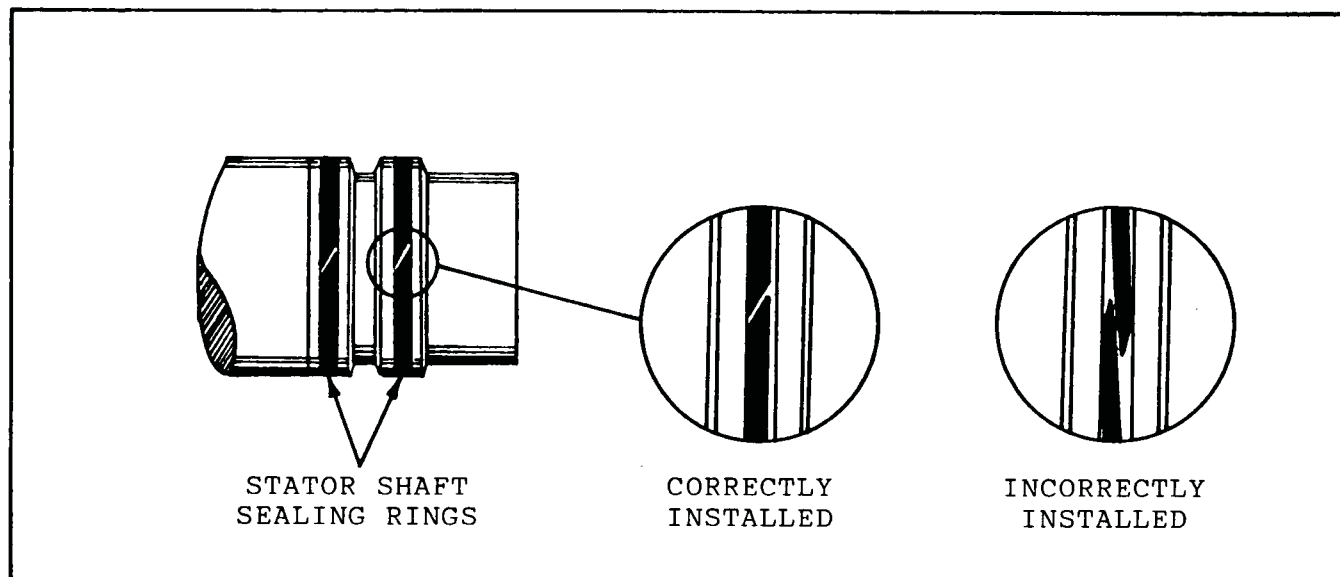

Figure 100

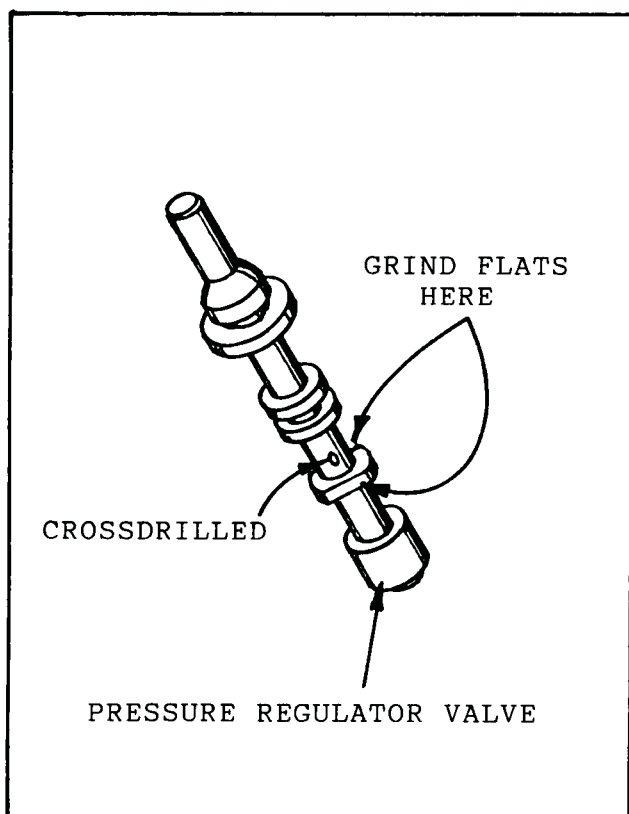

Figure 101

ASSEMBLE PUMP BODY AND COVER (Cont'd)

32. Install thrust washer on back of pump cover, insuring that washer tabs are in slots. Retain with petrolatum.
33. Install stator shaft sealing rings as shown in Figure 100. Retain with petrolatum.
34. Install the pump to case "O" ring into the groove in pump body.
35. The chamfered edge of the "O" ring should be out, and make sure it is not twisted in the groove.
36. Lubricate the "O" ring seal, and stator shaft sealing rings with petrolatum for ease of assembly.
37. Oil pump assembly is now ready for assembly into transmission.

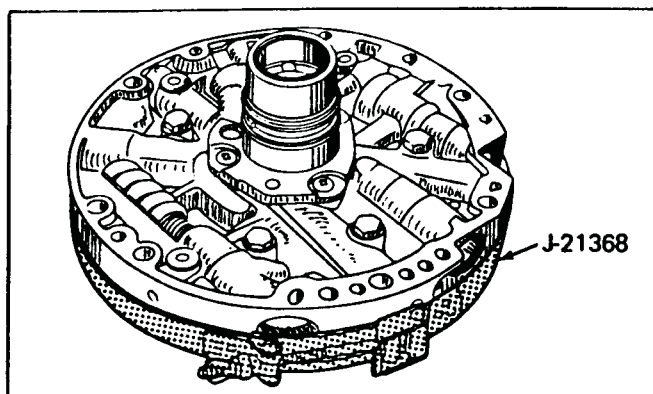

Figure 102

INSTALL OIL PUMP ASSEMBLY

1. Install oil pump to case gasket into case. Retain with petrolatum.
2. Lubricate case pump bore where "O" ring rides for ease of installation.
3. Install new washers or "O" rings onto front pump retaining bolts.
4. Install oil pump assembly into transmission case, and insure that all holes are aligned properly.
5. Install oil pump assembly retaining bolts.
6. Torque retaining bolts to 18 ft. lbs.
7. Install the proper "O" ring onto the turbine shaft AFTER end clearance is checked and properly set (See Figure 103)

CAUTION:

There should be clearance between the reverse input housing and the sun gear shell. When installed these two parts have a normal end clearance of approximately .150". DO NOT try to shim the internal parts because of this clearance.

CHECKING TRANSMISSION END PLAY

1. Remove a front pump bolt and install an 11" bolt and lock nut (See Figure 105).
2. Install J-25022 adapter, or J-34725 adapter, as shown in Figure 104 on turbine shaft.
3. Install pump remover tool as shown in Figure 105.
4. Install dial indicator, and set to zero (See Figure 105).
5. Pull up on pump remover, and record end play.
6. Proper end play should be .005" - .036".

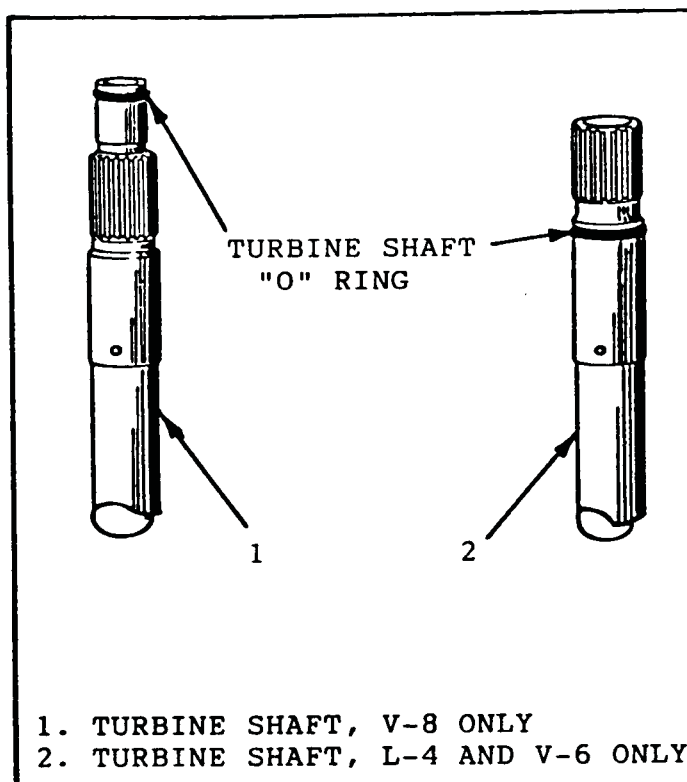

Figure 103

NOTE:

The selective washer which controls the end play is located between the input housing and the thrust bearing that rides on the oil pump cover hub. If more or less end play is required, select the proper washer from the chart in Figure 106 and install. If dial indicator shows no end play, the selective washer and thrust bearing have probably been misassembled. See Figure 72 for proper assembly.

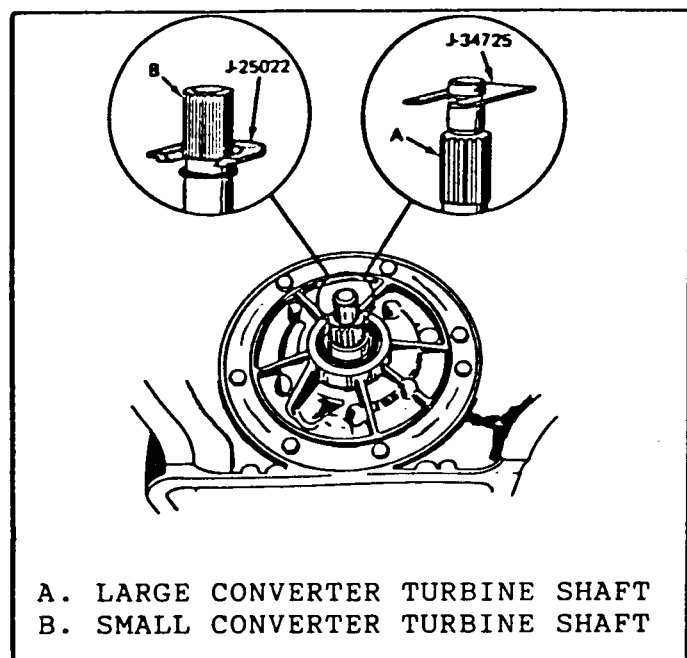

Figure 104

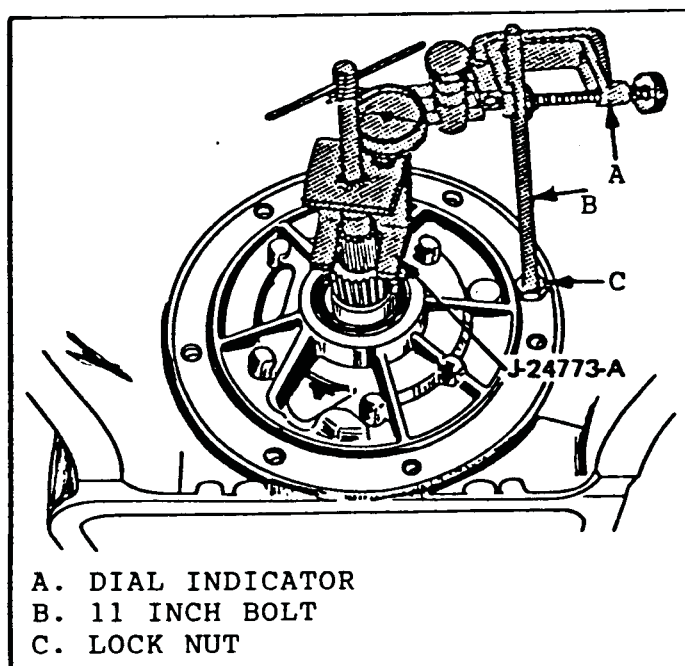

Figure 105

TRANSMISSION END PLAY WASHER SELECTION CHART	
WASHER THICKNESS	I.D.
.074" - .078"	67
.080" - .084"	68
.087" - .091"	69
.094" - .098"	70
.100" - .104"	71
.107" - .111"	72
.113" - .118"	73
.120" - .124"	74

Figure 106

ACCUMULATORS AND ASSOCIATED PARTS

1. Inspect the 1-2 accumulator cover and pin assembly for, porosity or damage, scored piston wall, and plugged oil passage.
2. Inspect the 1-2 and 3-4 accumulator pistons for porosity, ring groove damage, and pin bore wear.
3. We recommend installing 87 model accumulator pistons that have lathe cut rubber seals instead of the Teflon seals. They are available under OEM #8648998.

4. Inspect the 1-2 and 3-4 accumulator springs for distortion or damage.
5. Inspect spacer plate for damage.
6. Inspect checkballs for damage.

ASSEMBLE ACCUMULATORS

1. Install the 3-4 accumulator pin into the case. Make sure that the orificed cup plug is present in the bottom of accumulator bore.
2. Install the accumulator piston seal onto the 3-4 accumulator piston. We recommend 87 model accumulator pistons and seals. They are available under OEM part number 8648998.
3. Lubricate piston seal and accumulator bore with petrolatum.
4. Install the 3-4 accumulator piston onto the pin with the three legs facing up.
5. Carefully push and turn the 3-4 accumulator piston down into the case.
6. Install the 3-4 accumulator spring on top of the piston in the case.
7. Install governor screen into the case. See Figure 107 for location.

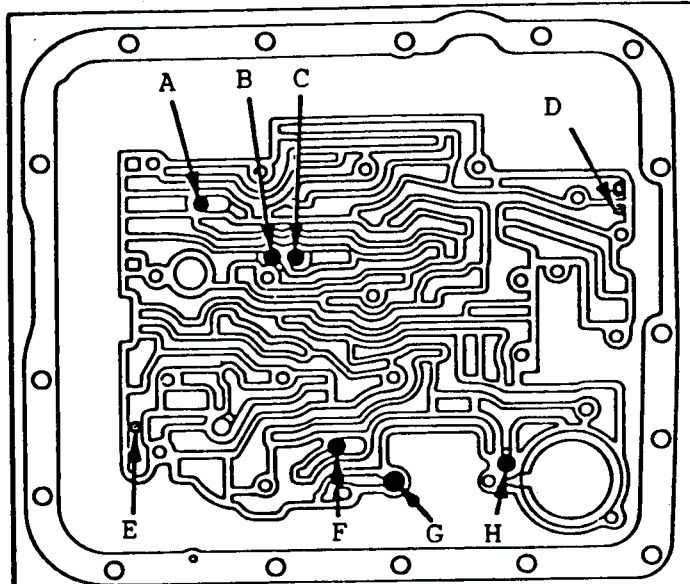

- A. #9 CHECKBALL (DETENT/LOW)
- B. #4 CHECKBALL (3-2 EXHAUST)
- C. #8 CHECKBALL (1-2 SHIFT)
- D. GOVERNOR SCREEN LOCATION
- E. TCC SOLENOID SCREEN LOCATION
- F. #3 CHECKBALL (PT THROTTLE/D3)
- G. #10 CHECKBALL (TV EXHAUST)
- H. #1 CHECKBALL (4TH ACCUMULATOR)

Figure 107

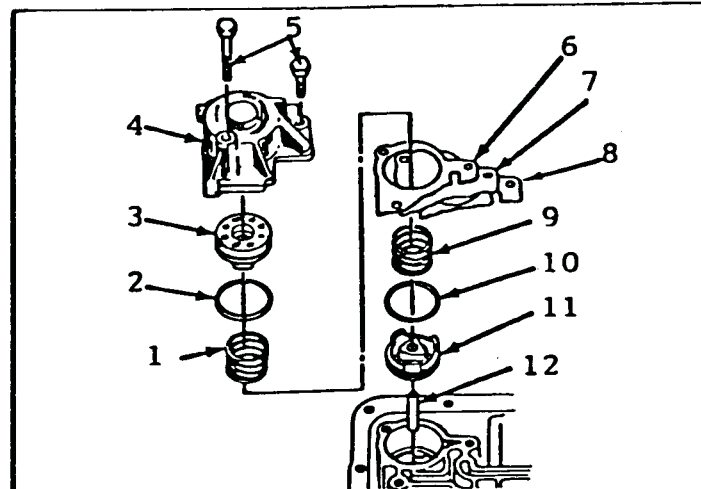

- 1. 1-2 ACCUMULATOR SPRING
- 2. 1-2 ACCUMULATOR SEAL
- 3. 1-2 ACCUMULATOR PISTON
- 4. 1-2 ACCUMULATOR COVER
- 5. 1-2 ACCUMULATOR COVER BOLTS
- 6. VALVE BODY/SPACER GASKET
- 7. SPACER PLATE
- 8. SPACER PLATE/CASE GASKET
- 9. 3-4 ACCUMULATOR SPRING
- 10. 3-4 ACCUMULATOR SEAL
- 11. 3-4 ACCUMULATOR PISTON
- 12. 3-4 ACCUMULATOR PIN

Figure 108

- 8. Install converter clutch screen into the case. See Figure 107 for location.
- 9. Install five (5) checkballs into the case in the locations shown in Figure 107.
NOTE: We recommend that you omit the number 10 (TV Exhaust) check ball. This will be the largest of the checkballs. Refer to Figure 107.
- 10. Install guide pins into the case for gasket, spacer plate, and valve body alignment.
- 11. Install spacer plate to case gasket over the guide pins and onto the case. This gasket is identified by a "C" punched into the gasket.
- 12. Install spacer plate over guide pins and down on top of the case gasket.
- 13. Install valve body to spacer plate gasket over the guide pins and down on top of the spacer plate.
- 14. This gasket can be identified by a "V" punched into the gasket.
- 15. Install the accumulator piston seal onto the 1-2 accumulator piston. We recommend 1987 model accumulator pistons and seals. They are available under OEM part number 8648998.
- 16. Lubricate piston seal and 1-2 accumulator housing bore with petrolatum.
- 17. Install the 1-2 accumulator piston into the bore of the 1-2 accumulator housing, with the 3 legs of the piston facing you as you install it (See Figure 108).
- 18. Install the 1-2 accumulator spring into the 1-2 accumulator housing on top of the piston.
- 19. Install 1-2 accumulator housing assembly onto case.
- 20. Install retaining bolts and torque to 8 ft. lbs.
- 21. Install oil passage cover plate and torque bolts to 8 ft. lbs.

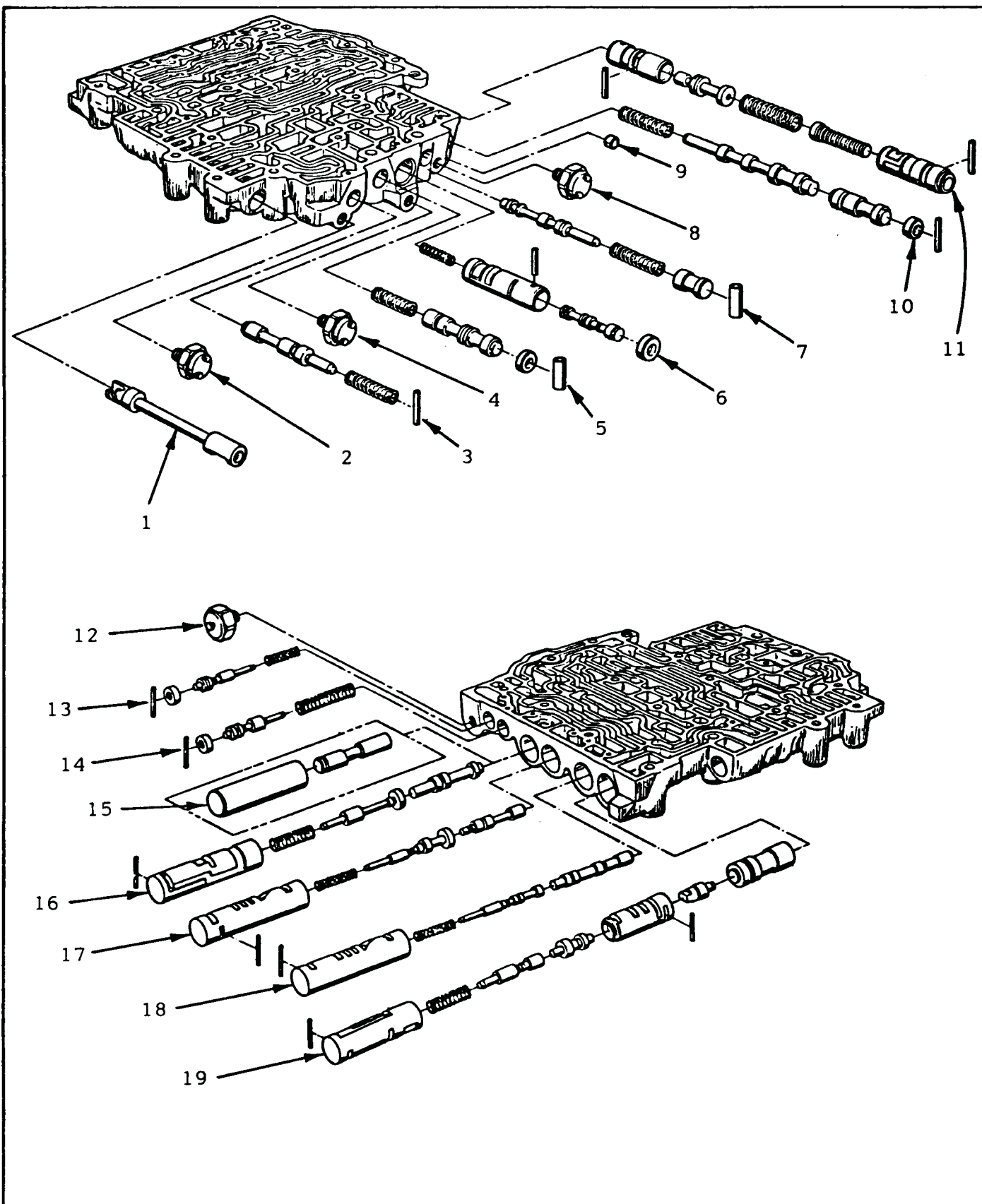

Figure 109

AUTOMATIC TRANSMISSION SERVICE GROUP



1. MANUAL VALVE
2. 3RD CLUTCH PRESSURE SWITCH
3. 3-2 CONTROL VALVE TRAIN
4. 4-3 PULSE SWITCH
5. LINE BIAS VALVE TRAIN
6. 1-2 ACCUM VALVE TRAIN
7. TV LIMIT VALVE TRAIN
8. 4TH CLUTCH PRESSURE SWITCH
9. CUP PLUG (4TH CLUTCH BORE)
10. 3-4 RELAY & 4-3 SEQUENCE VALVE
11. TV VALVE TRAIN
12. TCC SIGNAL SWITCH
13. MTV DOWNSHIFT VALVE TRAIN
14. MTV UPSHIFT VALVE TRAIN
15. ALUMINUM PLUGS FOUND IN THIS BORE ON SOME ECM MODELS
16. TCC THROTTLE VALVE TRAIN
17. 3-4 SHIFT VALVE TRAIN
18. 2-3 SHIFT VALVE TRAIN
19. 1-2 SHIFT VALVE TRAIN

Figure 110

VALVE BODY ASSEMBLY

1. Clean valve body assembly thoroughly in clean solvent. Move the valves with a pick or small screwdriver to dislodge any debris or dirt that may have accumulated.
2. Air dry completely.
3. Position valve body as shown in Figure 109, and on a clean dry surface.
4. Remove all valve trains. Some of the valve trains are under spring pressure, so cover the bores while removing roll pins.
5. Remove the blind hole roll pins with a modified drill bit. (Sharpened like a pencil).
6. All bore plugs, valves, springs, and bushings should be laid out on a clean, dry surface, in the exact sequence they are removed.
7. Remove and check all pressure switches for operation.
8. Clean all bore plugs, valves, springs, bushings, and valve body in clean solvent.
9. Air dry all parts using compressed air.

10. Inspect all valves for scoring, nicks, or scratches.
11. Inspect all bushings for nicks, scoring, scratches, and for porosity or cracks.
12. Inspect all springs for damaged or distorted coils.
13. Inspect valve body casting for porosity, cracks, interconnected oil passages, or any damage to the machined surfaces.

ASSEMBLE THE VALVE BODY

1. Assemble the valve body exactly as shown in Figures 109 and 110.
2. Notice the position of the valve lands, and the bushing passages.
3. Make sure that all roll pins are reinstalled.
4. The roll pins that go into blind holes must be pushed all the way down.
5. Install three (3) checkballs as shown in Figure 111, and retain with petrolatum.
6. Install valve body assembly on transmission as you hook manual valve. See Figure 113.
7. Install all valve body retaining bolts, brackets, wire clips, and T.V. lever and bracket assembly.
8. Torque all bolts to 8 ft. lbs.
9. Install "O" ring onto electrical connector, and install into case.
10. Install "O" ring onto solenoid and wiring harness assembly and install into case.
11. Torque bolts to 8 ft. lbs.
12. Insure that all switches are properly connected, and that you have installed the right wiring harness (See Figure 18).
13. Install parking bracket, bolts and torque to 18 ft. lbs.
14. Install two (2) "O" rings onto filter neck and install filter into transmission.
15. Install oil pan gasket on case.
16. Install magnet in pan, and install oil pan.
17. Torque oil pan bolts to 12 ft. lbs.

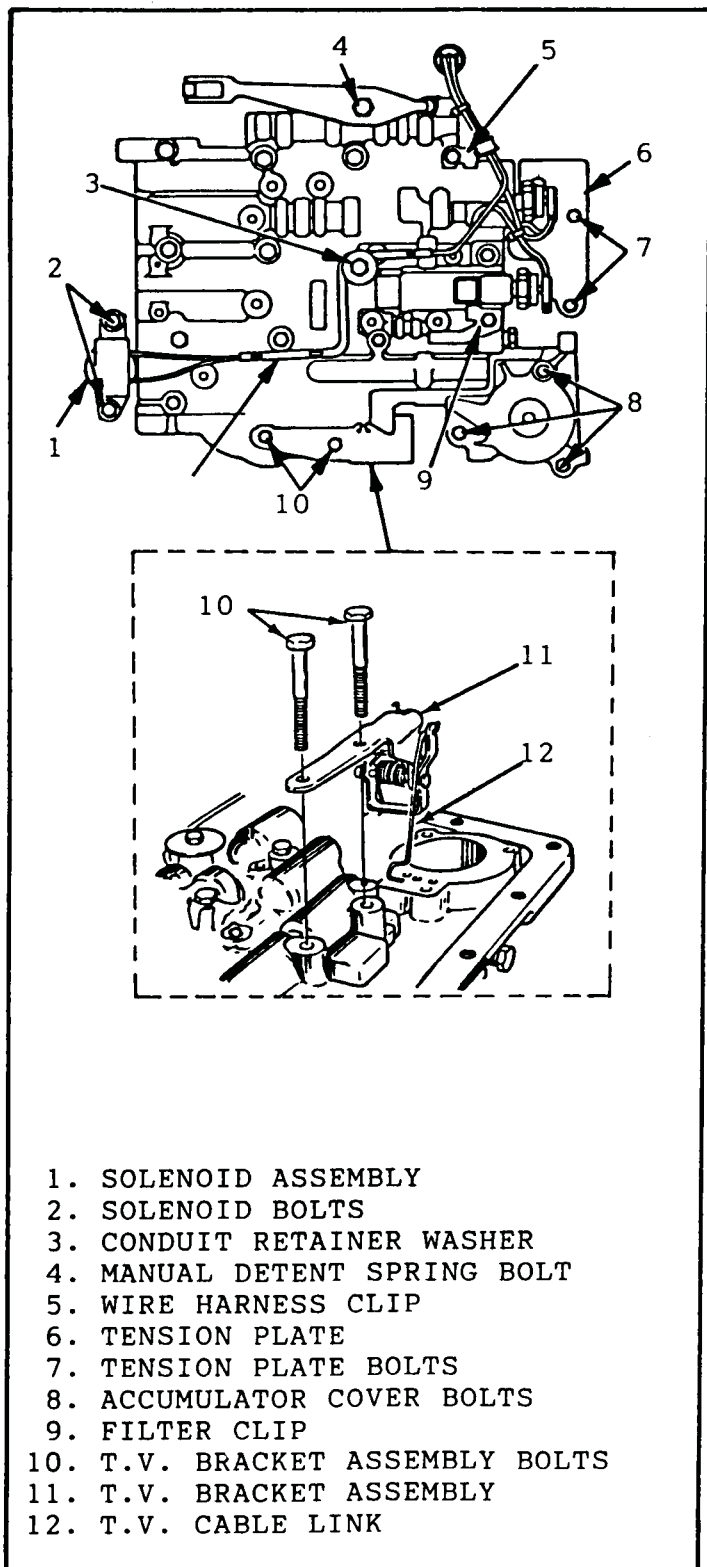

Figure 112

1. SOLENOID ASSEMBLY
2. SOLENOID BOLTS
3. CONDUIT RETAINER WASHER
4. MANUAL DETENT SPRING BOLT
5. WIRE HARNESS CLIP
6. TENSION PLATE
7. TENSION PLATE BOLTS
8. ACCUMULATOR COVER BOLTS
9. FILTER CLIP
10. T.V. BRACKET ASSEMBLY BOLTS
11. T.V. BRACKET ASSEMBLY
12. T.V. CABLE LINK

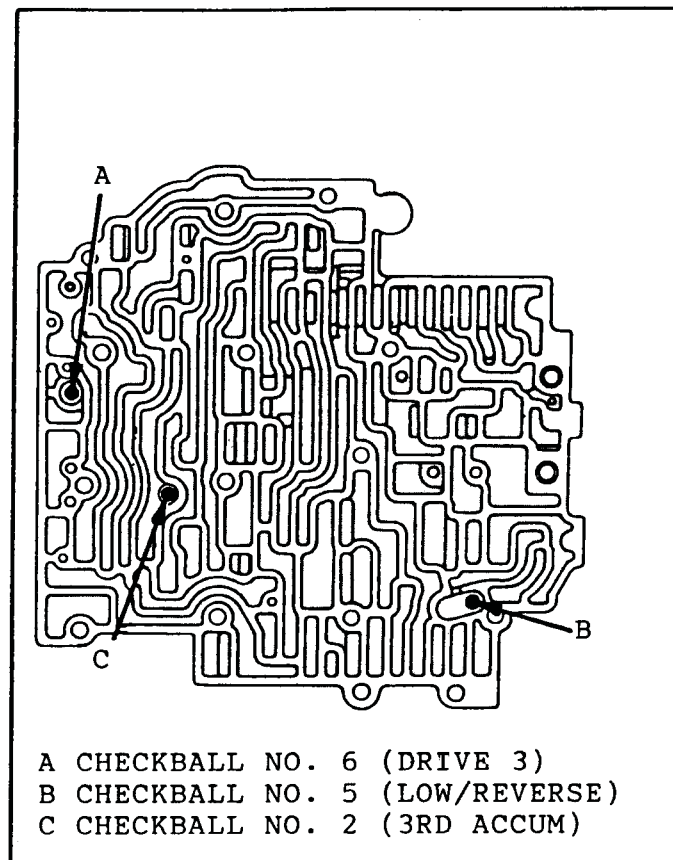

Figure 111

- A CHECKBALL NO. 6 (DRIVE 3)
- B CHECKBALL NO. 5 (LOW/REVERSE)
- C CHECKBALL NO. 2 (3RD ACCUM)

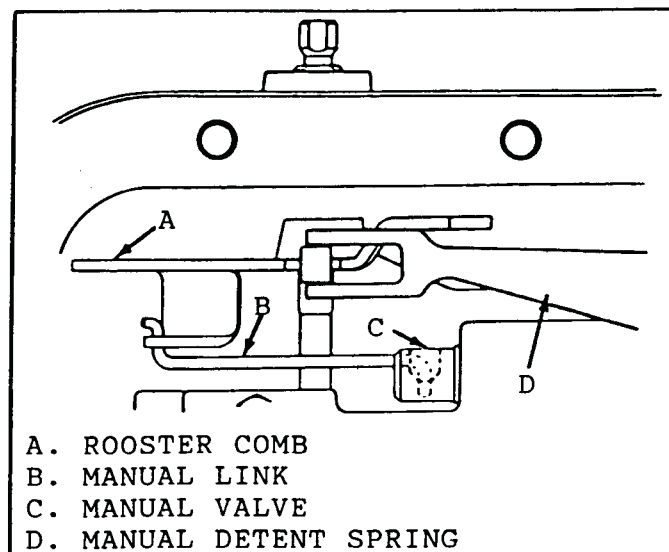

Figure 113

- A. ROOSTER COMB
- B. MANUAL LINK
- C. MANUAL VALVE
- D. MANUAL DETENT SPRING

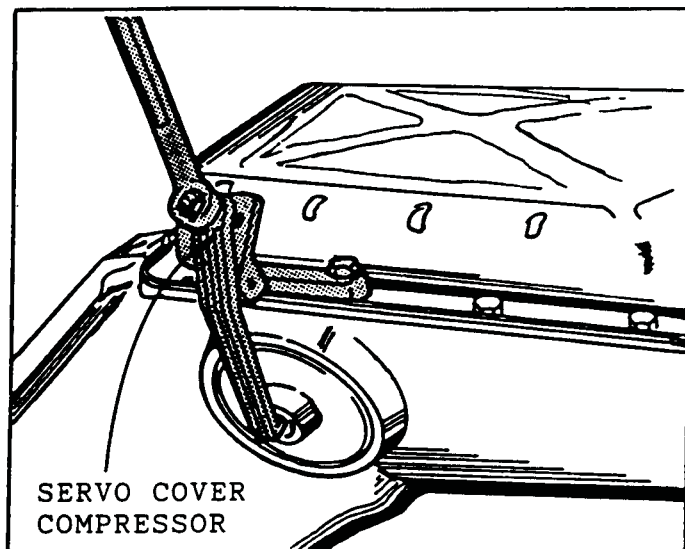
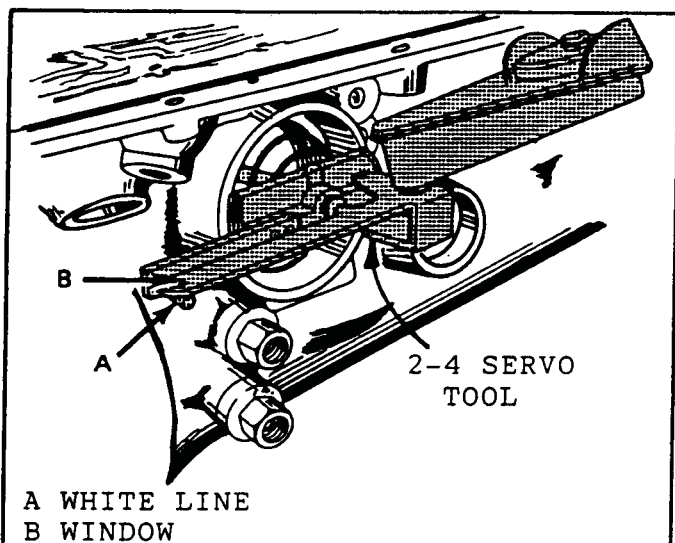

Figure 114



A WHITE LINE
B WINDOW

2-4 SERVO PIN SELECTION

PIN LENGTH		PIN I.D.
mm	INCH	
66.37-66.67	2.61-2.62	2 RINGS
67.74-68.04	2.67-2.68	3 RINGS
69.11-69.41	2.72-2.73	WIDE BAND

Figure 115

ASSEMBLE 2-4 SERVO ASSEMBLY

1. Inspect the pistons and servo cover for porosity or damage, ring groove damage, and springs for damage or distortion.
2. Inspect servo pin for wear or burrs.
3. Install cushion spring into the 2nd apply piston.
4. Use Figures 118 and 119 for the assembly process.
5. Install cushion spring retainer on the cushion spring.
6. Install J-22269-01 compressor and compress the retainer past the snap ring groove in the 2nd apply piston (See Figure 116).
7. Install the snap ring into the 2nd apply piston.
8. Install the 2nd apply piston assembly onto the apply pin with the retainer towards the shoulder of the pin.
9. Install apply pin spring on the pin.
10. Install apply pin washer and "E" clip onto the pin.
11. Install inner and outer seals on the 2nd apply piston, and retain them with petrolatum.
12. Install the servo inner housing on the 2nd apply piston and "O" ring onto the servo inner housing.
13. Install apply pin seals onto the servo apply pin.
14. Install sealing ring onto the 4th apply piston.

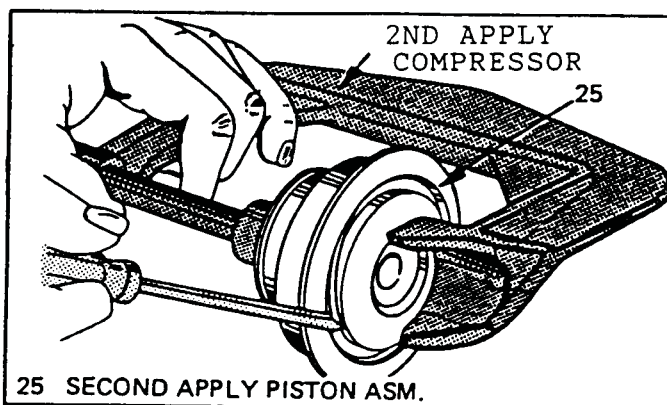
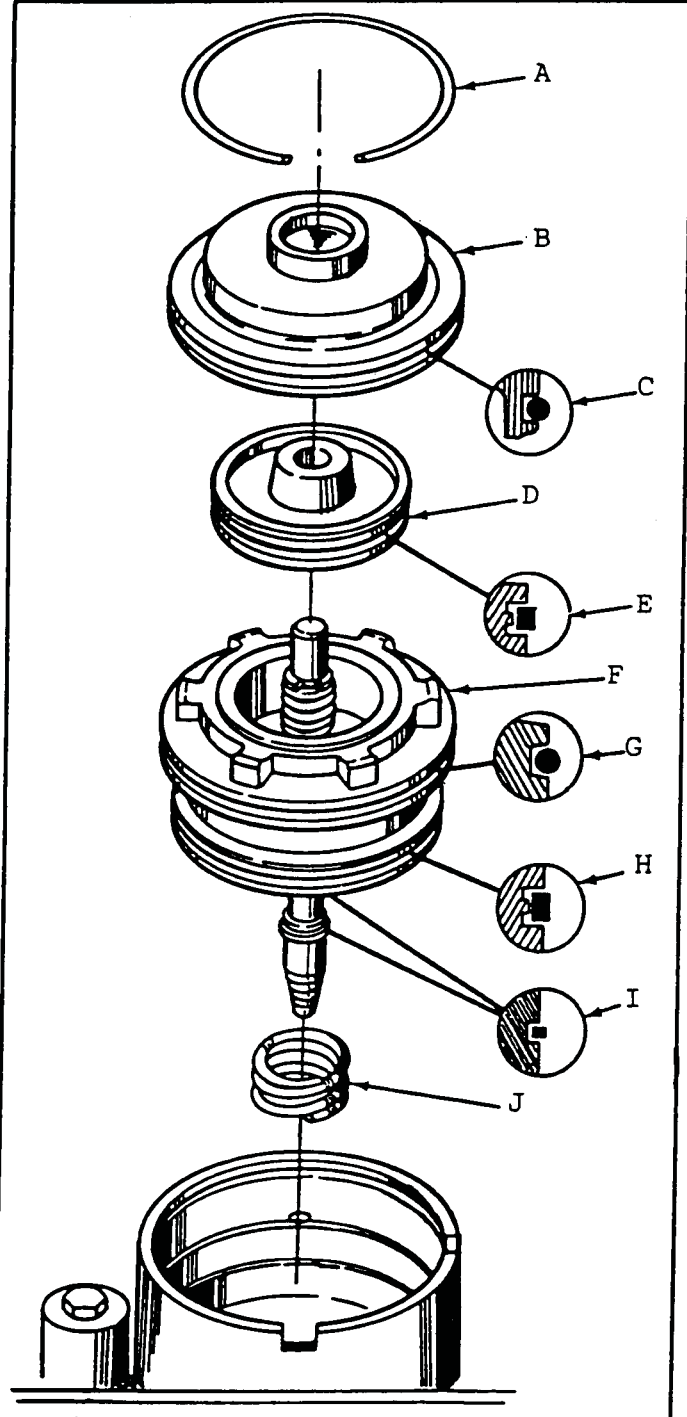
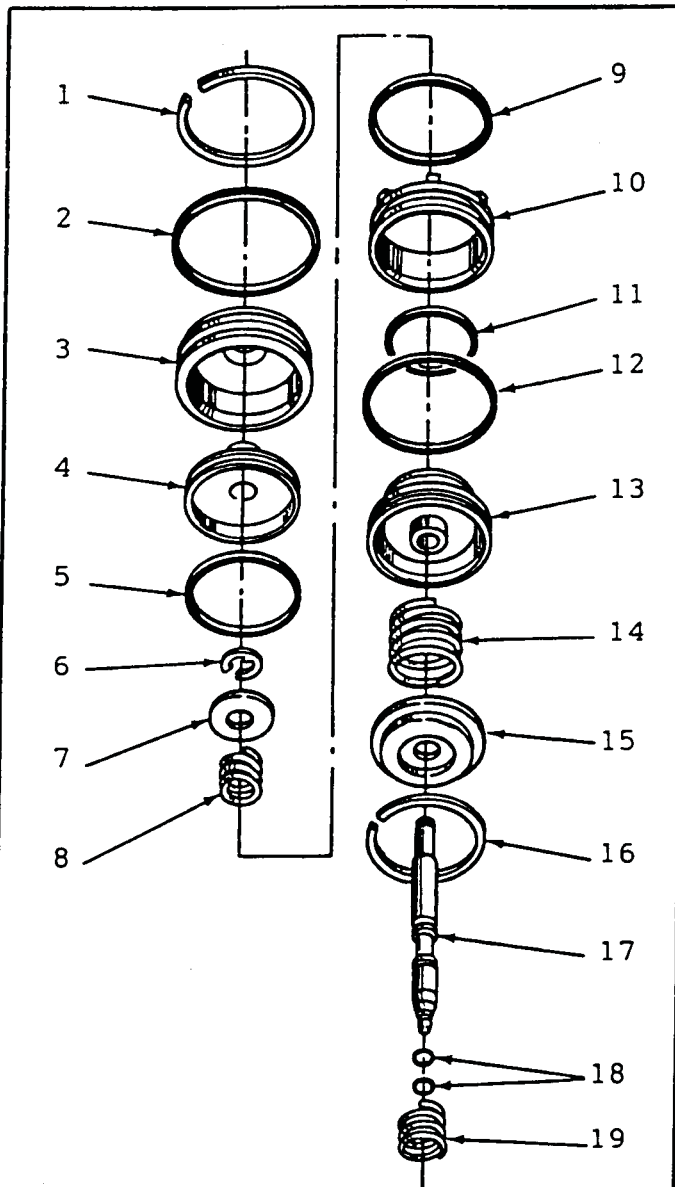

Figure 116



- A SERVO COVER SNAP RING
- B SERVO COVER
- C SERVO COVER "O" RING
- D 4TH APPLY PISTON
- E 4TH APPLY PISTON SEAL RING
- F SERVO PISTON INNER HOUSING
- G INNER HOUSING "O" RING
- H 2ND APPLY PISTON OUTER SEAL
- I APPLY PIN SEALING RINGS
- J SERVO RETURN SPRING

Figure 117



- 1 SERVO COVER SNAP RING
- 2 SERVO COVER "O" RING
- 3 2-4 SERVO COVER
- 4 4TH APPLY PISTON
- 5 4TH APPLY PISTON SEAL RING
- 6 APPLY PIN "E" CLIP
- 7 APPLY PIN WASHER
- 8 APPLY PIN SPRING
- 9 SERVO INNER HOUSING "O" RING
- 10 SERVO INNER HOUSING
- 11 2ND APPLY PISTON INNER SEAL
- 12 2ND APPLY PISTON OUTER SEAL
- 13 2ND APPLY PISTON
- 14 2ND APPLY CUSHION SPRING
- 15 CUSHION SPRING RETAINER
- 16 2ND APPLY PISTON SNAP RING
- 17 2-4 SERVO APPLY PIN(SELECTIVE)
- 18 SERVO PIN SEALING RINGS
- 19 SERVO PIN SPRING

Figure 118

15. Install the 4th apply piston onto the servo apply pin (Refer to Figure 119 for proper assembly).
16. Install servo return spring onto the servo apply pin.
17. Install servo piston assembly into the case servo bore.
18. Install "O" ring on the servo cover and lubricate with petrolatum.
19. Install servo cover into the case servo bore.
20. Install servo compressor tool, and compress servo cover.
21. Install servo cover snap ring and remove servo compressor.

BAND PIN SELECTION (IF NECESSARY)

1. Install J-33037 with with apply pin as shown in Figure 115.
2. Apply 100 in. lbs. torque.
3. If white line appears in the window of the tool, band pin length is correct.
4. Use the band pin selection chart in Figure 115 to determine correct pin length.

ASSEMBLE GOVERNOR AND COVER

1. Inspect the governor support pin for proper depth (See Figure 120 for proper dimension).
2. Inspect the governor valve inside the governor shaft, and the governor weights for free operation.
3. Inspect the governor shaft for nicks or burrs.
4. Inspect the governor driven gear for damage. Replace if necessary.
5. Install the governor assembly into the case governor bore.
6. Apply sealant, such as loctite cup plug sealant #11 or equivalent to governor cover flange before installation (See Figure 121).
7. Install governor cover using a C-6 servo cover as an installation tool so as not to distort governor cover.

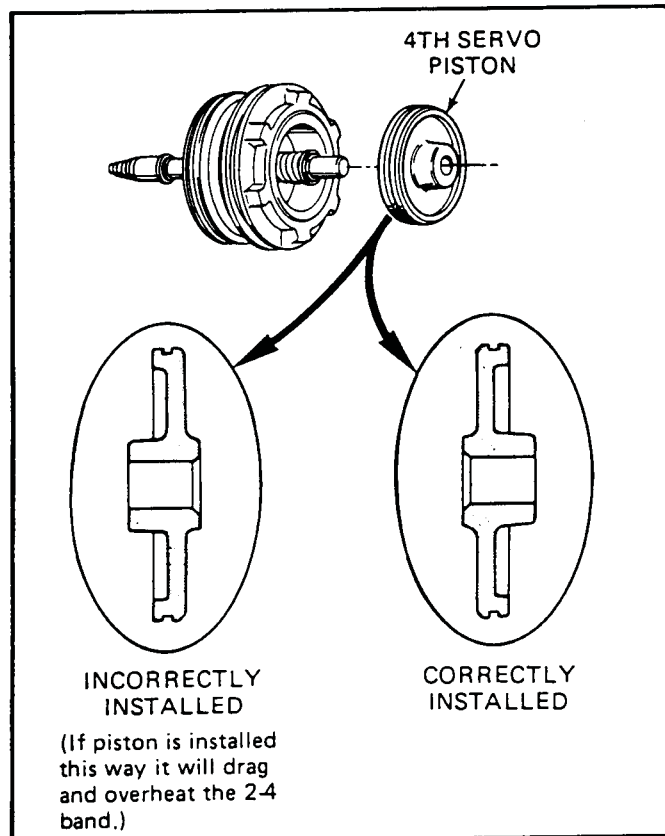

Figure 119

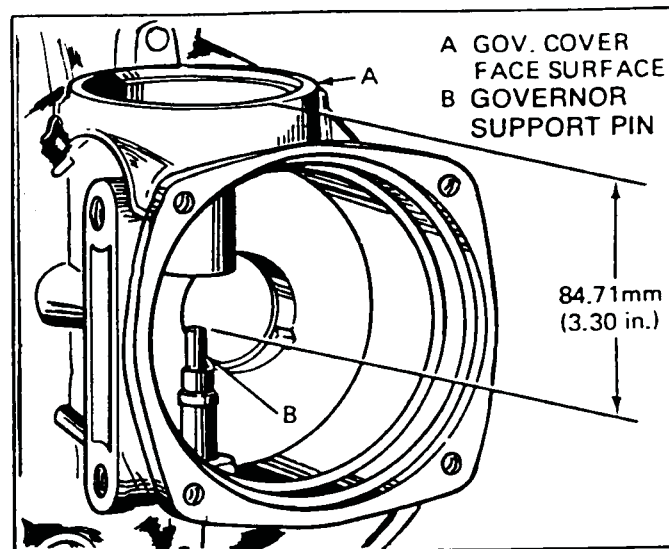

Figure 120

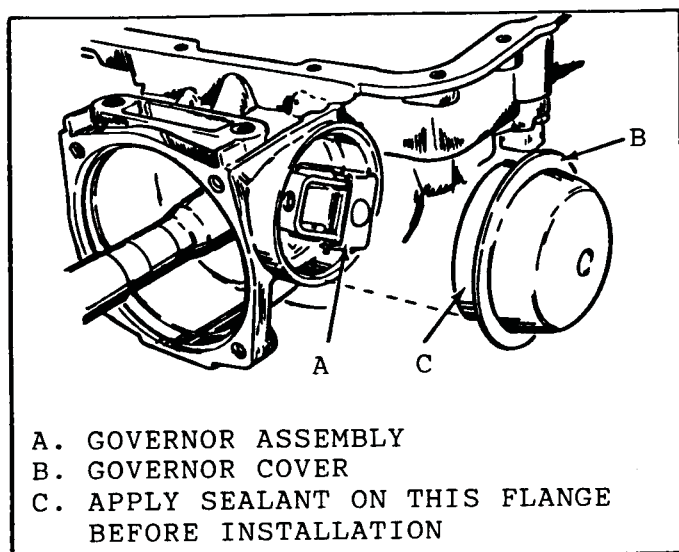

Figure 121

CHECK GOVERNOR END PLAY

1. With governor cover installed check governor end play between plastic gear and support pin.
2. Turn output shaft in direction that will move governor toward support pin, and move governor toward cover by hand.
3. Governor end play should be no more than 1/16", and no less than about 0.40".
4. Change governor end play by tapping lightly on the center of governor cover.

ASSEMBLE EXTENSION HOUSING

1. Install speedometer drive gear and retaining clip onto the output shaft.
2. If the output shaft has two speedometer locating holes, use the hole nearest the splines for Corvette only, all others use the front hole (Figure 123).
3. Install "O" ring in the output shaft sleeve (See Figure 124).
4. Install output shaft sleeve on the output shaft. Do not push the sleeve past the machined surface on the output shaft (See Figure 125).
5. Install square cut seal ring on the extension housing, and install the extension housing rear seal.

6. Install extension housing so the speedometer bore is on the same side of the case as the governor.
7. Install four extension housing bolts and torque to 26 ft. lbs.
8. Install "O" ring on speedometer adapter, and lip seal inside of the adapter.
9. Install driven speedometer gear and install complete assembly into the case.
10. Install manual shift lever and nut onto manual shaft.
11. Remove the transmission from the holding fixture.
12. Lubricate torque converter hub with petrolatum and install the torque converter.

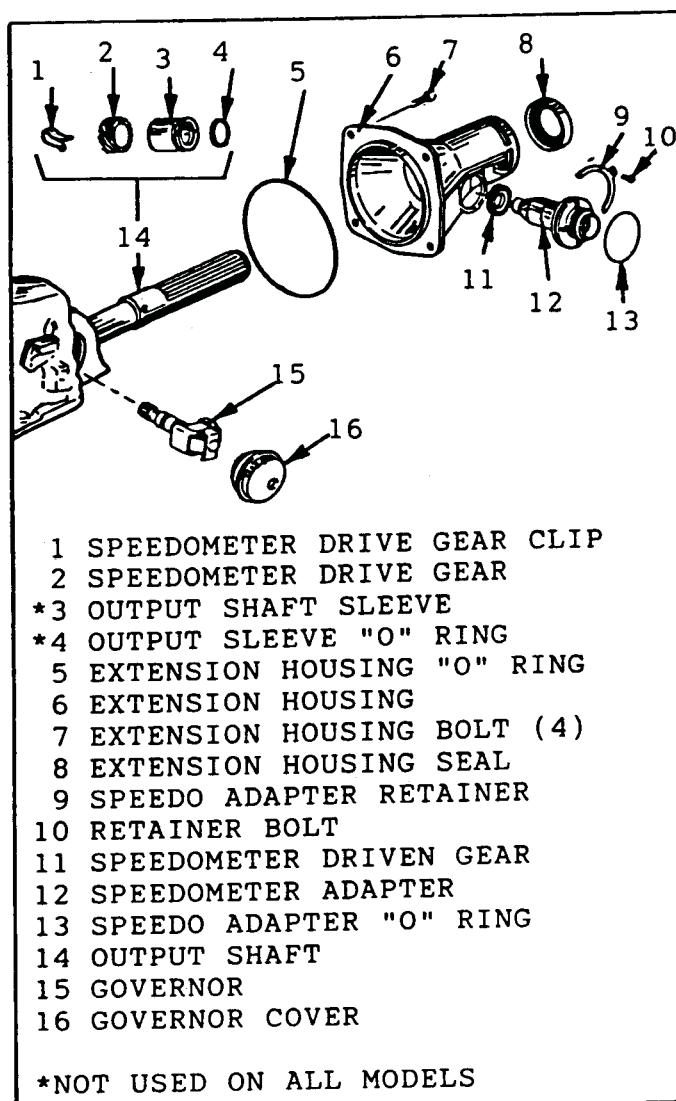

Figure 122

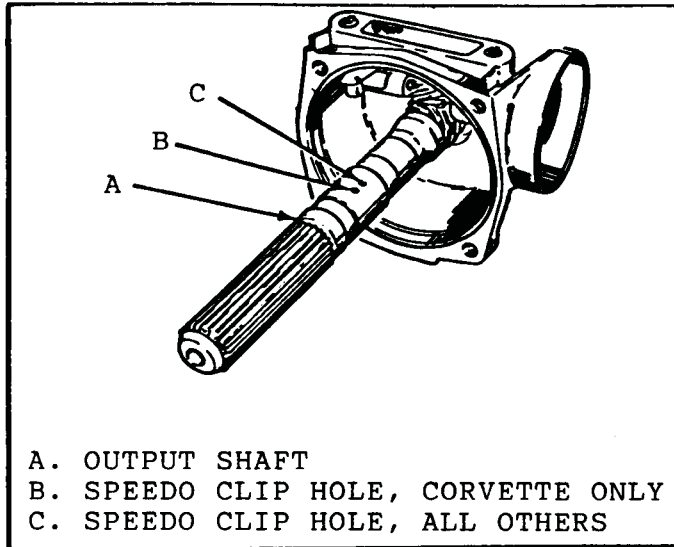

Figure 123

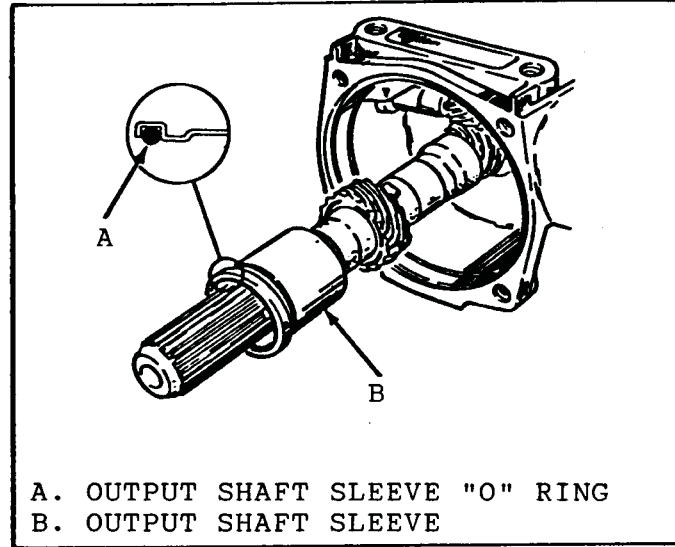

Figure 124

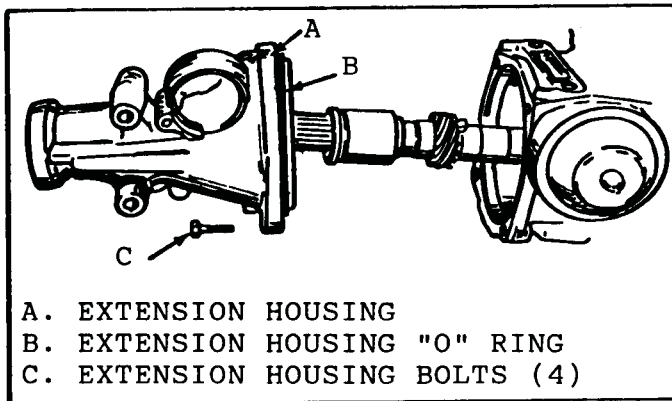
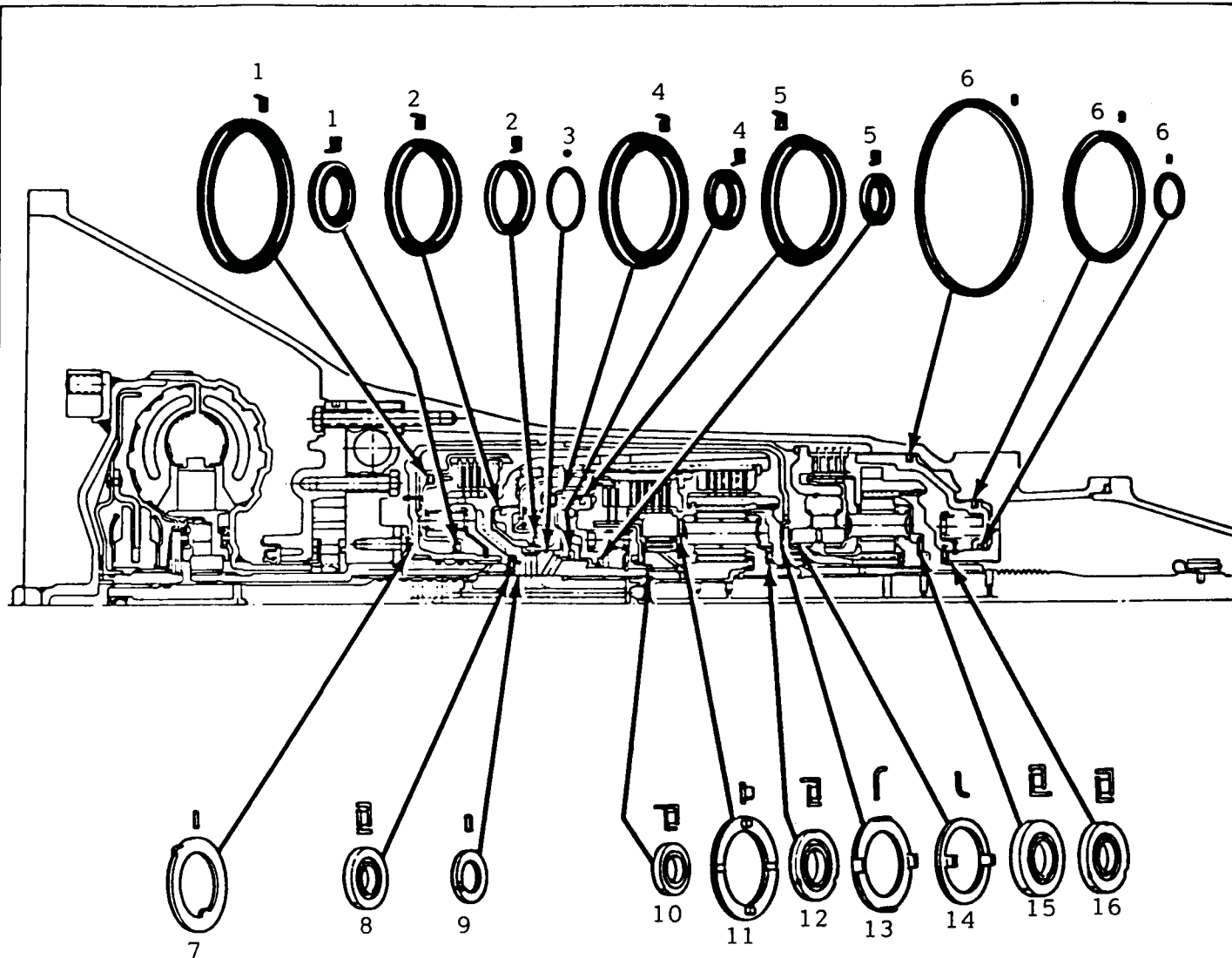

Figure 125



- | | |
|---|--|
| 1. INNER & OUTER REVERSE INPUT SEALS | 12. BEARING ASSEMBLY (INPUT CARRIER/
REACTION SHAFT) |
| 2. INNER & OUTER 3-4 CLUTCH SEALS | 13. THRUST WASHER (REACTION SHAFT/
SUN GEAR SHELL) |
| 3. INPUT HOUSING "O" RING SEAL | 14. THRUST WASHER (LOW OVERRUN CLUT.
INNER RACE/SUN GEAR SHELL) |
| 4. INNER & OUTER FORWARD CLUT. SEALS | 15. BEARING ASSEMBLY (REACTION
CARRIER/RING GEAR SUPPORT) |
| 5. INNER & OUTER OVERRUN CLUT. SEALS | 16. BEARING ASSEMBLY (RING GEAR
SUPPORT/TRANSMISSION CASE) |
| 6. OUTER, CENTER, AND INNER LOW &
REVERSE CLUTCH SEALS | |
| 7. THRUST WASHER (PUMP COVER/REVERSE
INPUT HOUSING) | |
| 8. BEARING ASSEMBLY (STATOR SHAFT/
SELECTIVE WASHER) | |
| 9. THRUST WASHER (SELECTIVE) | |
| 10. BEARING ASSEMBLY (INPUT SUN GEAR/
INPUT HOUSING) | |
| 11. THRUST WASHER (INPUT CARRIER/FWD
SPRAG OUTER RACE) | |

Figure 126

AUTOMATIC TRANSMISSION SERVICE GROUP



In April, 1988, General Motors introduced a new Solenoid and Wiring Harness Assembly (Type 18), (See Figure 127) that eliminates the wire for the 4-3 pulse switch, and eliminates the 4-3 pulse switch in the valve body (See Figure 127). The function of the 4-3 pulse switch, to momentarily release the converter clutch during a 4-3 downshift, was programmed into the ECM for the 1988 model year, and is now a function of the computer. These models had previously used a Type 15 Solenoid and Wiring Harness Assembly.

Any 1988 THM 700-R4 transmission built with a Type 15 Solenoid Assembly can be serviced with the new Type 18 Solenoid Assembly. However, there will be no wire connection for the 4-3 pulse switch. The 4-3 pulse switch should be removed from the valve body, and a 1/8" pipe plug installed, to eliminate a leak point.

Type 15 Solenoid and Wiring Harness Assy..... 8654415
 Type 18 Solenoid and Wiring Harness Assy.....10478100

ProCarManuals.com

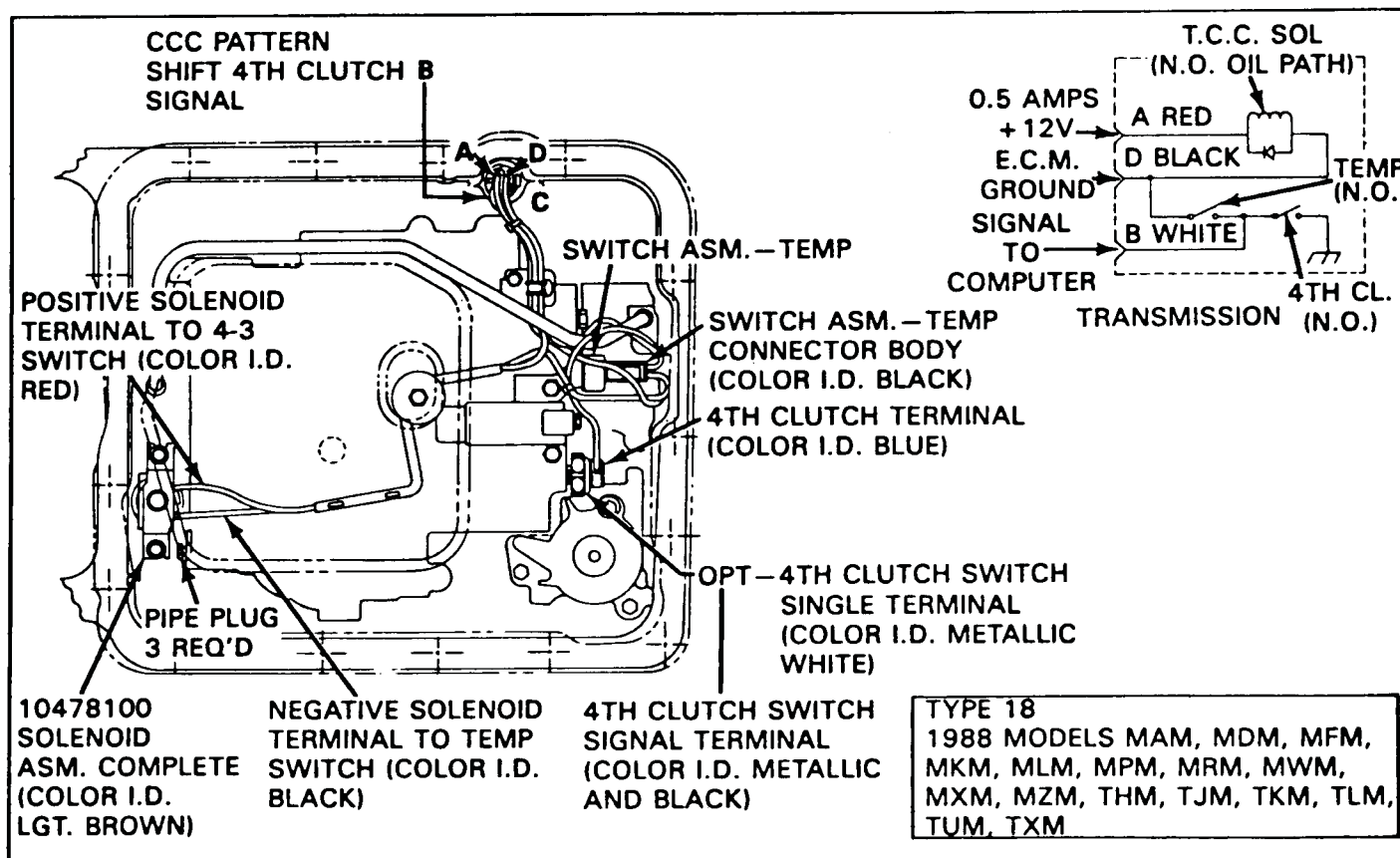

Figure 127

CHANGE: New design accumulator piston, seal, and spring (See Figure 128).

REASON: Improved shift consistency and smoothness.

PARTS AFFECTED:

1. Accumulator piston (See Figure 128).
2. Accumulator piston rubber seal.
3. Accumulator piston conical spring for some models (See Figure 128).

INTERCHANGEABILITY:

1. The new accumulator piston and rubber seal will retro fit, and is highly recommended, on all previous model THM 700-R4.
2. This new piston and seal is used in the 1-2, 3-4, and forward clutch accumulator (Located in Aux. valve body) on all 1987 model THM 700-R4 transmissions.
3. The new conical accumulator piston spring (Some Models), must be assembled with the large end into the piston

SERVICE INFORMATION:

1. This change went into production on June 18, 1986 (Julien 169).
2. Piston and seal package part number 8648998
3. Seal package part number 8635568

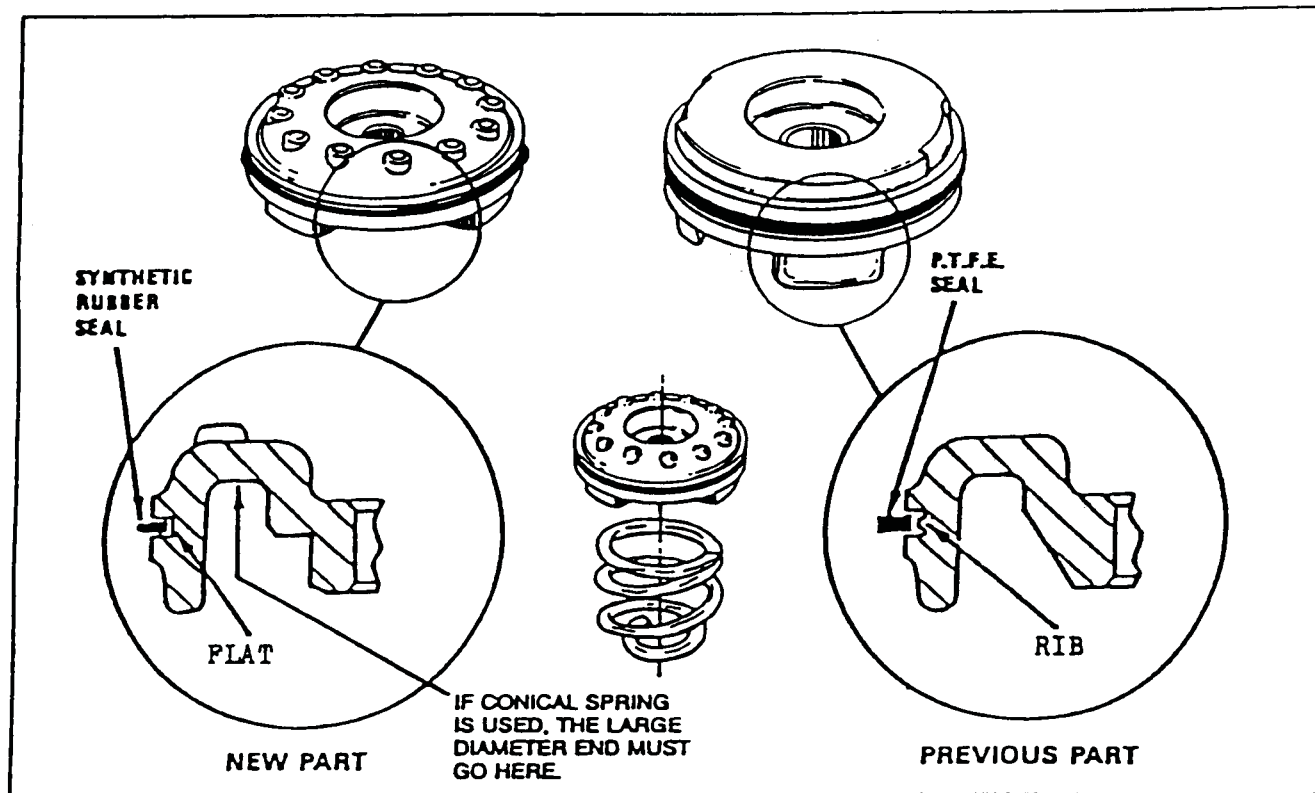

Figure 128



Technical Service Information

CHANGE: Oil Filter and Filter Seal - Beginning July 6, 1987 (Julian Date 187).

REASON: Eliminates the potential for transmission noise caused by air suction through the filter seal or filter neck.

PARTS AFFECTED:

- (1) Oil Filter - The new design filter is wider, has a felt element in place of the screen, and is bottom suction instead of top suction (See Figure 129).
- (2) Oil Filter Seal - Best description of the new seal is "It looks like "O" rings moulded together" (See Figure 129).

INTERCHANGEABILITY:

The new design filter and filter seal can be used on any 1982-1988 THM 700-R4 transmission. The filter retaining clip is not needed with the new design filter, and should be discarded.

SERVICE INFORMATION:

Seal, Oil Filter	8657767
Service Package, Filter, Filter Seal, Gasket	8657926

70 Seal, Oil Filter
71 Filter Assembly, Oil

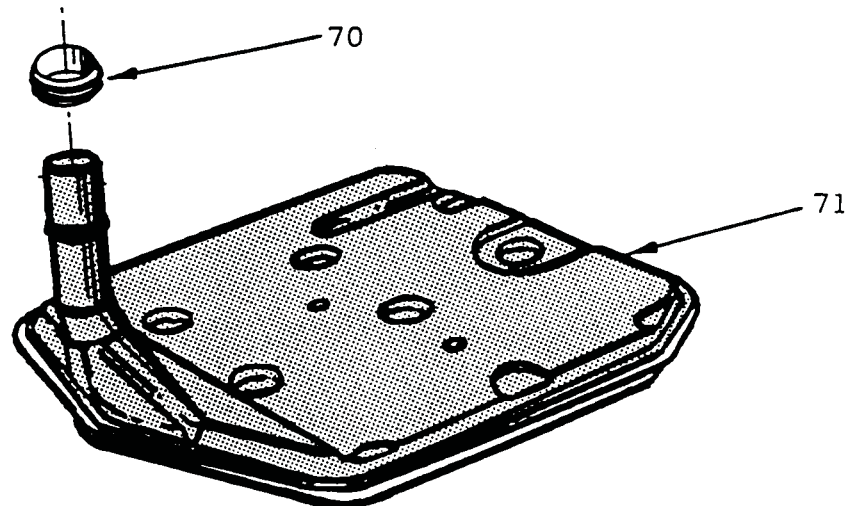

SPECIAL NOTE: Late filter will retro fit in MOST CASES. To be sure make the following check. Install pan without gasket. If the pan rocks, or is not flush with the pan rail on the case, then install the early filter or the late model deep pan.

Figure 129

AUTOMATIC TRANSMISSION SERVICE GROUP



THM 700-R4 NO 3-4 SHIFT

COMPLAINT: No 3-4 shift on any THM 700-R4 transmission.

CAUSE: The cause may be that you have installed the 3-4 relay valve in backwards. The 3-4 relay valve is located in front of the 4-3 sequence valve in the valve body (See Figure 130).

CORRECTION: Install the 3-4 relay valve correctly (See Figure 130).

ProCarManuals.com

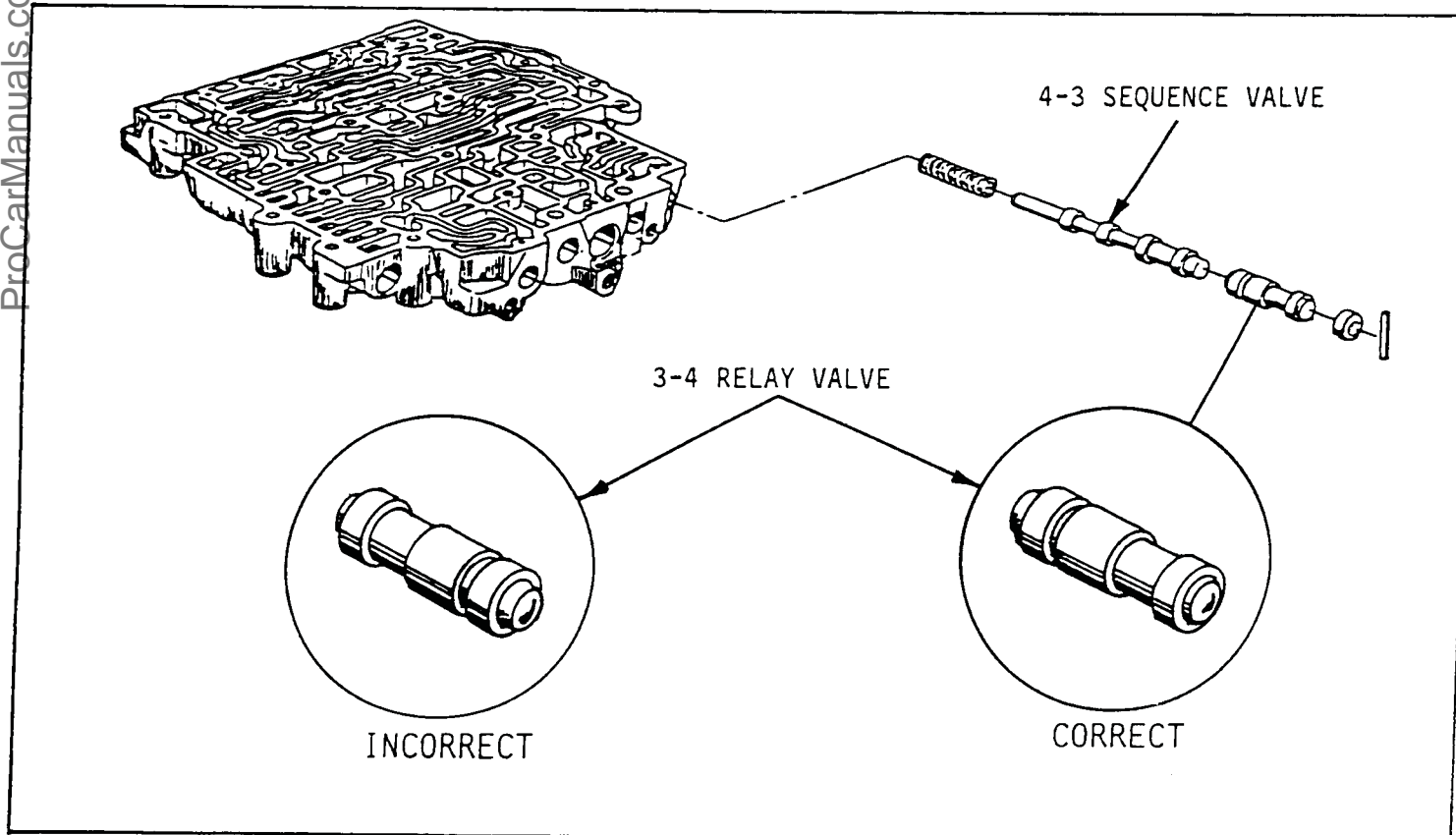

Figure 130



Technical Service Information

THM 700-R4 PREMATURE REVERSE INPUT CLUTCH FAILURE

- COMPLAINT:** Premature reverse input clutch failure on 1987 or 1988 models only.
- CAUSE:** The cause may be the orifice hole in the new aluminum piston, drilled too large (Original was .116").
- CORRECTION:** Plug the original hole from the back side of piston with an allen head set screw, flush or below. Retain the set screw with Loc-tite (See Figure 131, Inset "A").
- 180 degrees from original orifice hole you will find a hole started but not drilled through. Drill through here with a 1/16" drill bit, from the front side of piston. Turn the piston over and from the back side of piston, drill about half way through with a 1/8" drill bit. (See Figure 131, Inset "B").

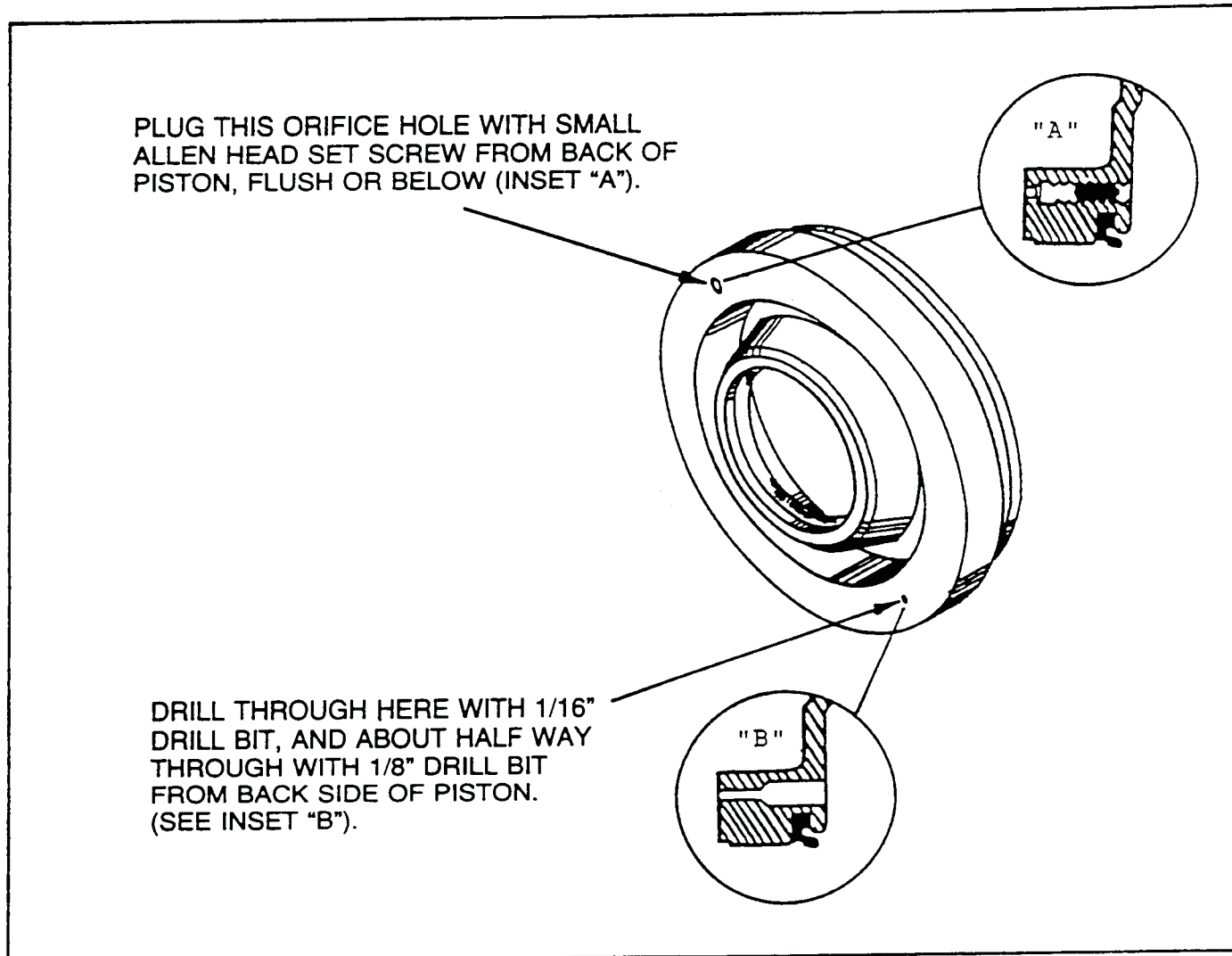

Figure 131



Technical Service Information

CHANGE: Forward Sprag Assembly

REASON: Improved Torque Carrying Capacity

PARTS AFFECTED:

1. Sprag Outer Race (644) - Larger inside diameter (See Figure 132).
2. Sprag Inner Race (641) - Larger outside diameter and longer lip on the retainer on the sprag inner race (See Figure 132).
3. Forward Sprag Assembly (642) - Increased diameter and addition of 2 more sprag elements (This increased elements from 26 to 28).
4. Solid Steel End Bearings (643) - See Figure 132.
5. Sprag Assembly Wear Plate (640) - Eliminated (See Figure 132).
6. Input Carrier Thrust Washer (660) - Eliminated (See Figure 132).

INTERCHANGEABILITY:

1. The new design Forward Sprag Assembly is highly recommended, and will retro fit back on all previous models, by replacing the "Entire Assembly".
2. Individual components are "NOT" interchangeable.
3. The input carrier thrust washer and wear plate are not required with the new design sprag. Use of the input thrust washer (660) with the new design sprag will create a misbuild as correct end play cannot be obtained.

SERVICE INFORMATION:

The new design Forward Sprag Assembly includes the new design Overrun Clutch Hub (Figure 133), and is available under OEM Part Number 8657928.

**CUT-AWAY VIEW
FORWARD SPRAG CLUTCH**

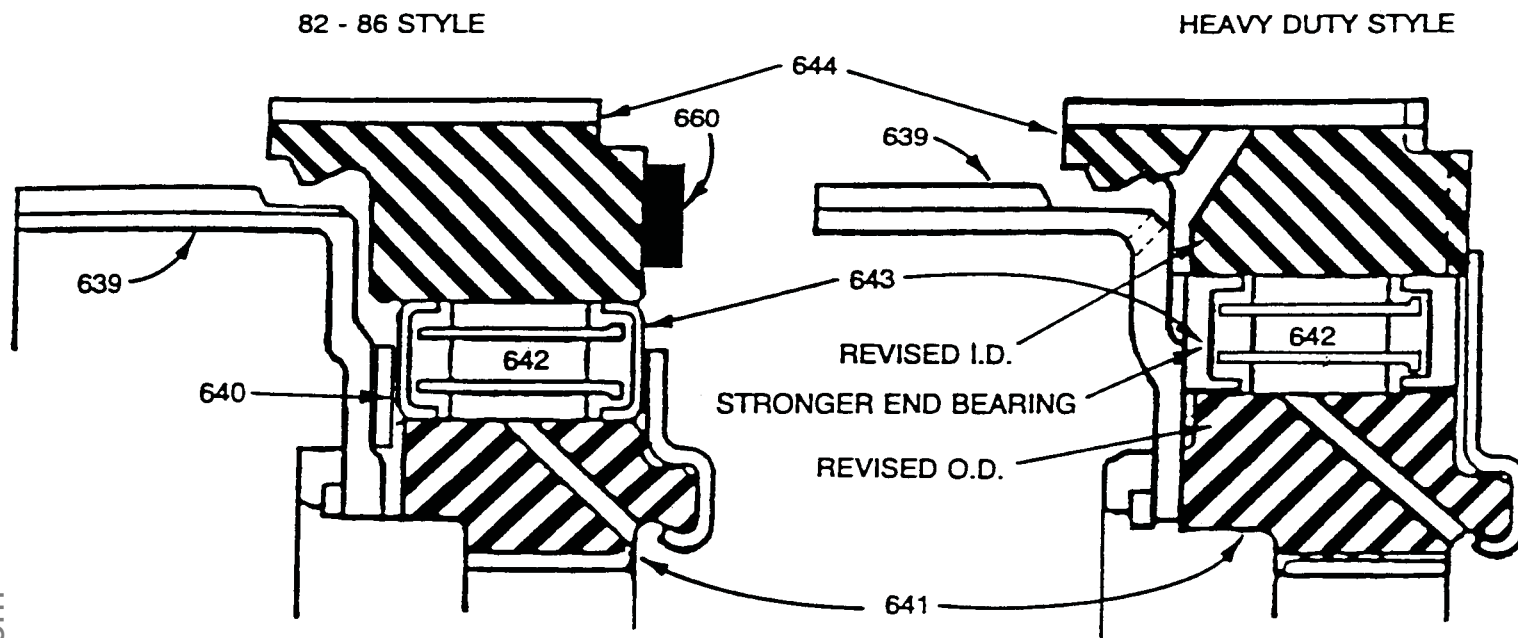

IMPORTANT: THESE PARTS ARE NOT REQUIRED WITH THE NEW LARGER DIAMETER DESIGN SPRAG.

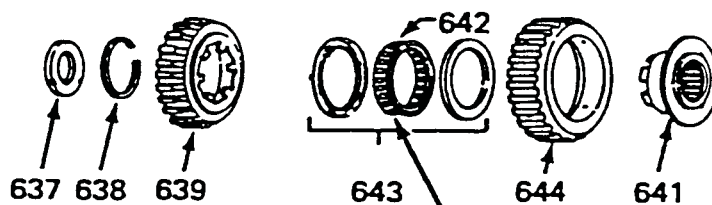
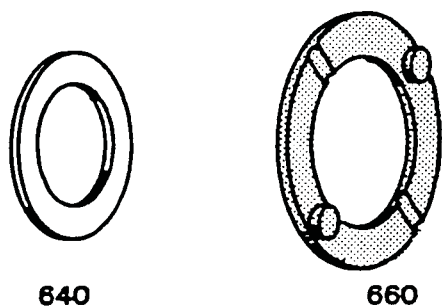

THE NOTCHES ABOVE EACH SPRAG MUST POINT UP AS SHOWN WHEN ASSEMBLED INTO THE OUTER RACE

ILL. NO.	DESCRIPTION
637	BEARING ASSEMBLY, INPUT SUN GEAR
638	SNAP RING, OVERRUN CLUTCH HUB RET.
639	HUB, OVERRUN CLUTCH
641	RETAINER & RACE ASSEMBLY, SPRAG
642	FORWARD SPRAG ASSEMBLY
643	RETAINER RINGS, SPRAG ASSEMBLY
644	RACE, FORWARD CLUTCH - OUTER

Figure 132

CHANGE: Overrun Clutch Lubrication

REASON: Improved durability of the overrun clutch plates by providing extra lubrication.

PARTS AFFECTED:

1. Overrun Clutch Hub – Now has 12 lube holes instead of the previous three, plus 3 angular holes, for a total of 15 lube holes (See Figure 133).

INTERCHANGEABILITY:

The new design Overrun Clutch Hub can be used in place of the old hub.

SERVICE INFORMATION:

The new design Overrun Clutch Hub will come as a part of the new design Forward Sprag Assembly, and the new sprag assembly is available under OEM Part No. 8657928.

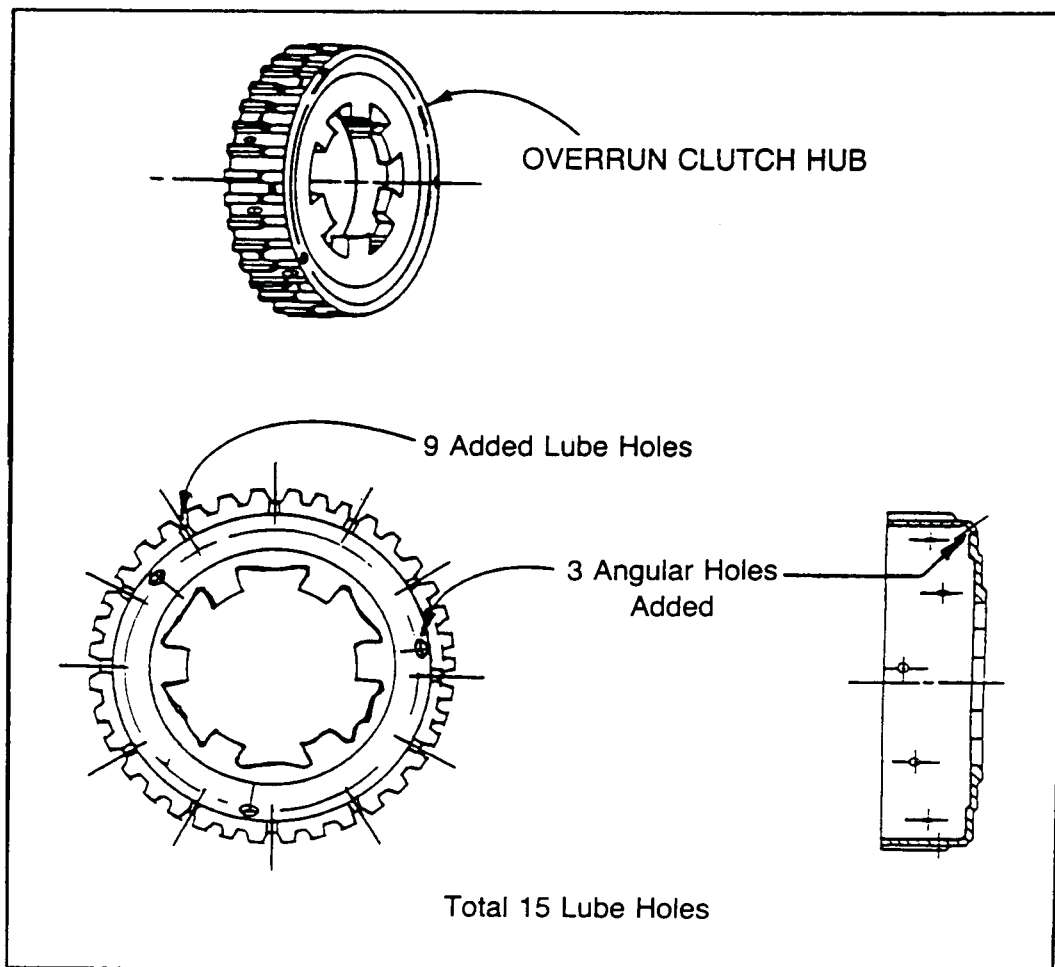

Figure 133

AUTOMATIC TRANSMISSION SERVICE GROUP



THM 700-R4

8642970 KIT IN THE ECM CONTROLLED MODELS

We all know that the factory installed an aluminum plug in the valve body, where the converter clutch T.V. sleeve normally goes. This was to block off the oil channels since TCC was no longer controlled by oil pressure, but controlled instead by the ECM. What some of us do not know, is that they installed "TWO" aluminum plugs. One to replace the converter clutch T.V. sleeve, and one to replace the converter clutch shift valve (See Fig. 134). You will have to remove "TWO" aluminum plugs from the valve body and in addition you will have to come up with a converter clutch shift valve from an old valve body, as it is not available from OEM sources.

With both aluminum plugs removed, install the "Aquired" converter clutch shift valve first and then your 8642970 kit. Be sure to clip one coil off of the spring that comes in the kit.

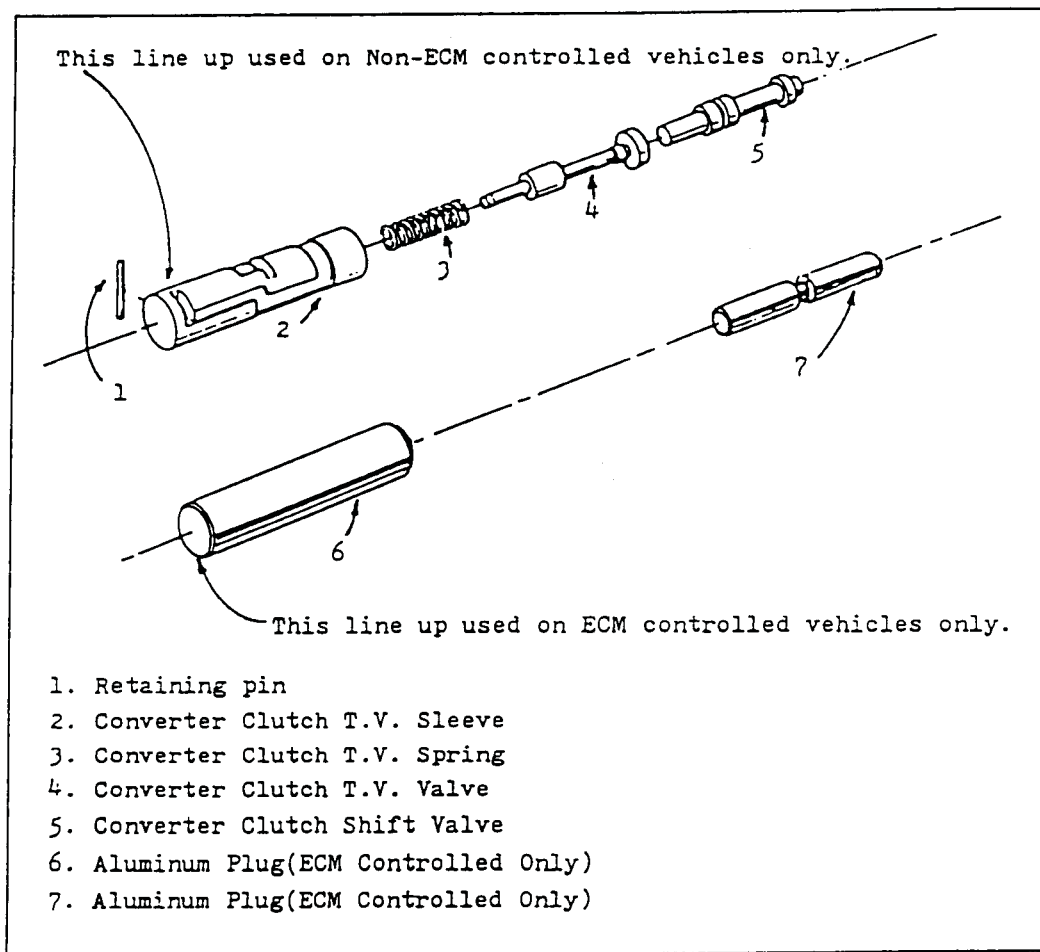

Figure 134

AUTOMATIC TRANSMISSION SERVICE GROUP



THM 700-R4

COMPLAINT: Harsh downshift clunk with selector in D3 only.
CAUSE: The cause could be the 2nd apply piston.
CORRECTION: Modify the 2nd apply piston by machining the inner hub and remove .125"

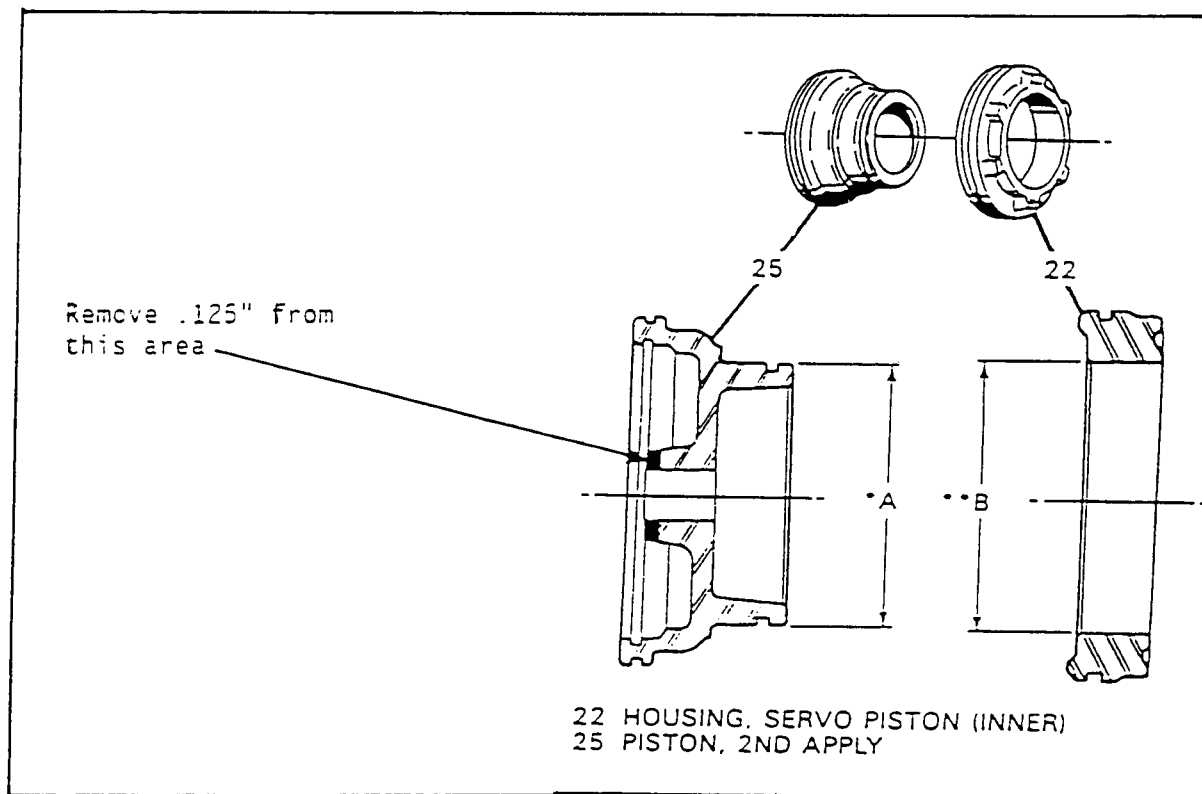

Figure 135

AUTOMATIC TRANSMISSION SERVICE GROUP