



THM 440-T4

INDEX

ROAD TEST PROCEDURE	3
RANGE REFERENCE CHART	5
OIL PRESSURE TEST	6
DIAGNOSTIC INFORMATION	7
UPDATED WIRING SCHEMATICS	14
COMPONENT OIL PASSAGE IDENTIFICATION (1985 HYDRAULICS)	21
COMPONENT OIL PASSAGE IDENTIFICATION (1985 1/2 HYDRAULICS)	95
TRANSAXLE DISASSEMBLY	33
TCC SCREEN LOCATION	40
CHANNEL PLATE CHECKBALL LOCATIONS	39
VALVE BODY CHECKBALL LOCATIONS	41
INSPECTION AND TRANSAXLE REASSEMBLY	51
END PLAY MEASUREMENT	66
SPEED SENSOR ROTOR TOOTH COUNT BY MODEL	87
TORQUE SPECIFICATIONS	90
SPECIAL TOOLS	92
1985 VERSUS 1985 1/2 MODEL IDENTIFICATION	93

"Portions of materials contained herein have been reprinted under license from General Motors Corp, Service & Parts Operations."

The information and part numbers contained in this booklet have been carefully compiled from industry sources known for their reliability, but ATSG does not guarantee its accuracy.

Copyright © ATSG 2002

**AUTOMATIC TRANSMISSION SERVICE GROUP
18639 SW 107TH AVENUE
MIAMI, FLORIDA 33157
(305) 670-4161**



*Updated
December, 2002*

INTRODUCTION THM 440-T4 (4T60)

We would like to thank General Motors Corporation for the information and illustrations that have made this booklet possible. This booklet contains the general description, diagnosis and overhaul procedures necessary to repair, overhaul, or service the THM 440-T4 overdrive automatic transaxle.

The THM 440-T4 is a fully automatic front wheel drive transaxle. It provides Park, Reverse, Neutral and four forward speeds, with fourth gear being overdrive. Changing of the four forward gears is fully automatic, in relation to vehicle speed and throttle position. Vehicle Speed Signals (Governor), Throttle Position Signals (T.V. Cable), and Engine Torque Signals (Modulator) are constantly sent to the transaxle valve body to provide the proper gear ratio for maximum efficiency and performance at all throttle openings.

No part of any ATSG publication may be reproduced, stored in any retrieval system or transmitted in any form or by any means, including but not limited to electronic, mechanical, photocopying, recording or otherwise, without *written* permission of Automatic Transmission Service Group. This includes all text illustrations, tables and charts.

"Portions of materials contained herein have been reprinted under license from General Motors Corp, Service & Parts Operations."

The information and part numbers contained in this booklet have been carefully compiled from industry sources known for their reliability, but ATSG does not guarantee its accuracy.

Copyright © ATSG 2002

DALE ENGLAND
FIELD SERVICE CONSULTANT

WAYNE COLONNA
TECHNICAL SUPERVISOR

PETER LUBAN
TECHNICAL CONSULTANT

JON GLATSTEIN
TECHNICAL CONSULTANT

ROLAND ALVAREZ
TECHNICAL CONSULTANT

GERALD CAMPBELL
TECHNICAL CONSULTANT

JIM DIAL
TECHNICAL CONSULTANT

ED KRUSE
TECHNICAL CONSULTANT

GREGORY LIPNICK
TECHNICAL CONSULTANT

DAVID CHALKER
TECHNICAL CONSULTANT

JERRY GOTT
TECHNICAL CONSULTANT

MIKE SOUZA
TECHNICAL CONSULTANT

AUTOMATIC TRANSMISSION SERVICE GROUP
18639 SW 107TH AVENUE
MIAMI, FLORIDA 33157
(305) 670-4161



ROAD TESTING PROCEDURE

PRELIMINARY CHECKS:

- * Check for proper transmission fluid level, and proper fluid color. Normal fluid is red in color.
- * Check T.V. cable and adjust as necessary.
- * Check manual linkage and adjust as necessary.
- * Check for cracked or broken vacuum lines on modulator and replace as necessary.
- * Engine must be properly tuned for accurate vacuum signals to the Vac. modulator.

PARK RANGE:

Position the selector lever in reverse on a slight incline. Park position allows the output shaft to be held, thus preventing the vehicle from rolling either forward or backward. For safety reasons the parking brake should be used in addition to "Park" range.

REVERSE RANGE:

Position the selector lever in reverse which will allow you to check operation in a rearward direction.

DRIVE RANGE:

Position the selector lever in Drive Range and accelerate slowly from a standing start. Check for a 1-2, 2-3, 3-4 upshift, and converter clutch engagement. Upshifts should vary depending on the amount of throttle opening. Converter clutch application speeds will also vary depending on model. Quality of the shifts should be observed at the time they occur. Check for part throttle and detent downshifts by depressing the accelerator at various speeds.

MANUAL 3 RANGE:

With vehicle speed at approximately 55 MPH, in fourth gear, manually shift the transaxle to D3. The transaxle should shift immediately into third gear. Let up on the accelerator and check for

grade retard or engine braking. Check for part throttle and detent downshifts by depressing the accelerator at various speeds.

MANUAL 2 RANGE:

With vehicle speed at approximately 50 MPH, in third gear, manually shift the transaxle into D2. The transaxle should immediately shift to 2nd gear, and the engine braking effect should be noticed. Check for a 2-1 detent downshift at speeds below 30 MPH by depressing the accelerator to the wide open throttle position.

MANUAL 1 RANGE:

Manual Low may be selected at any vehicle speed, however the transaxle will downshift only to 2nd gear, until the vehicle slows down below approximately 40 MPH, at which time it will downshift to Low Range. Engine RPM should increase and engine braking should be noticed. A 1-2 upshift should not occur in Low Range.

SERVICE NOTE:

If any malfunctions are discovered during the road test, a pressure gage and a vacuum gage should be installed on the transaxle and a thorough pressure test should be performed. See the appropriate section of this service manual for proper pressure testing procedures.

AUTOMATIC TRANSMISSION SERVICE GROUP

PARK-ENGINE RUNNING

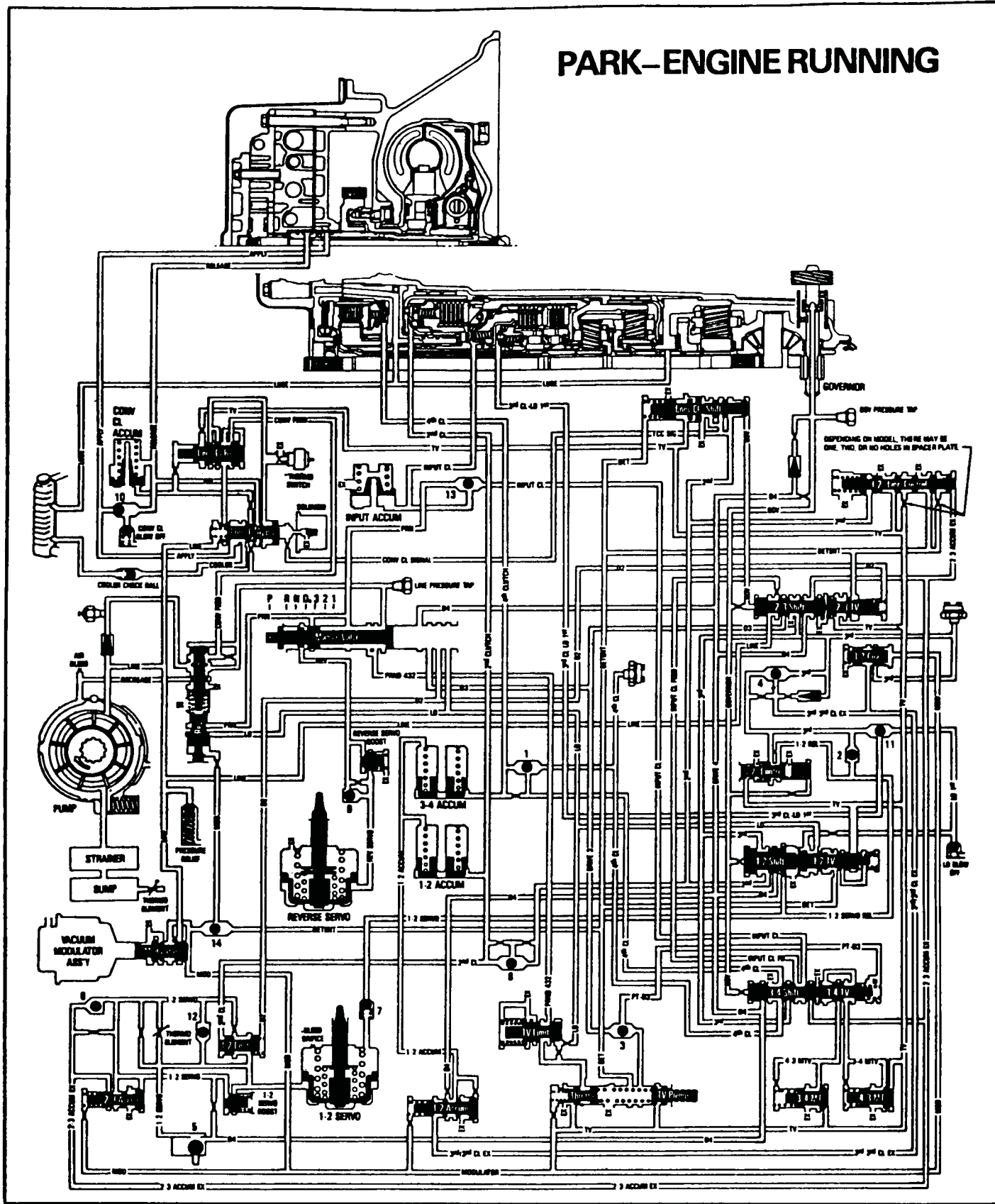

Figure 1

AUTOMATIC TRANSMISSION SERVICE GROUP

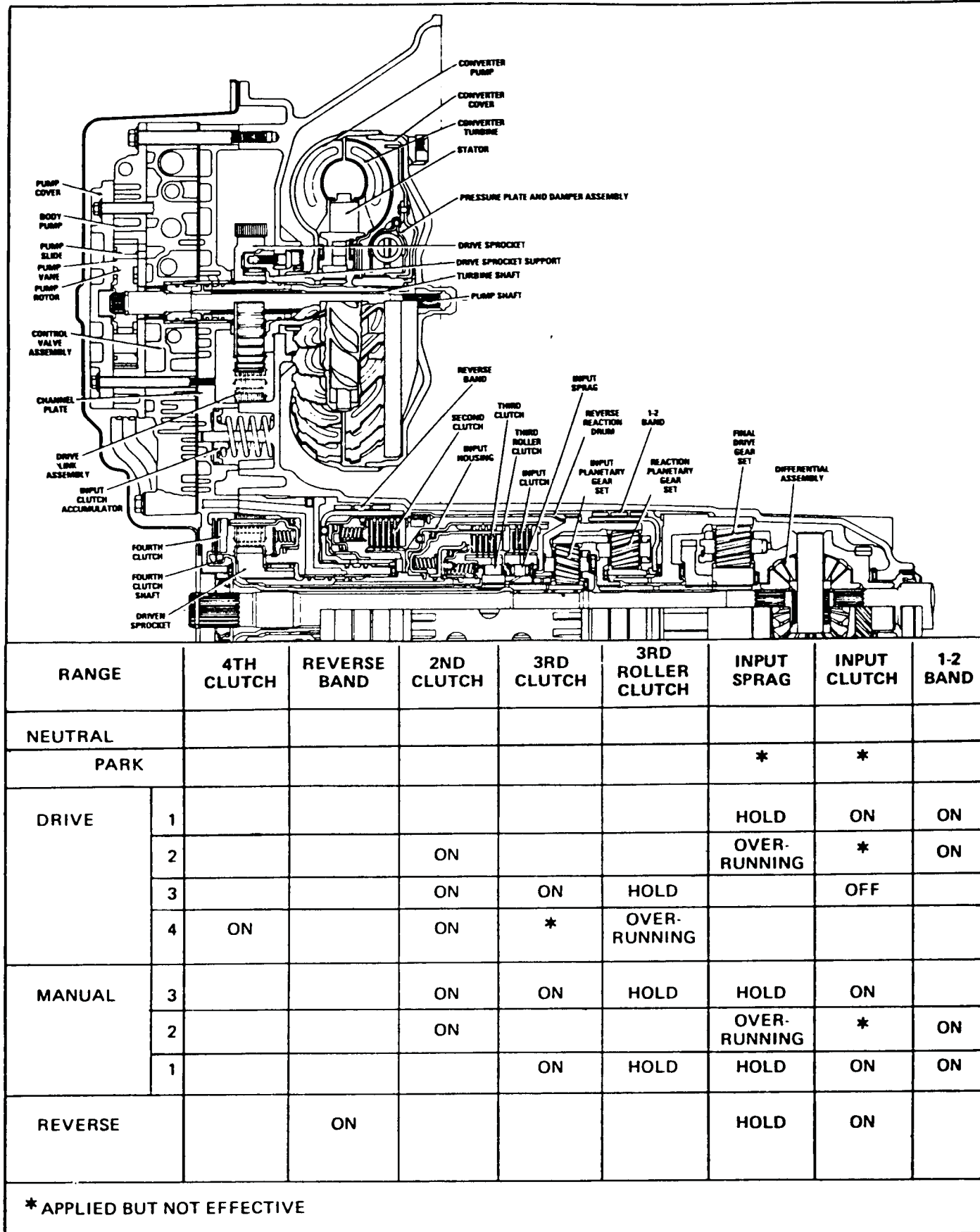
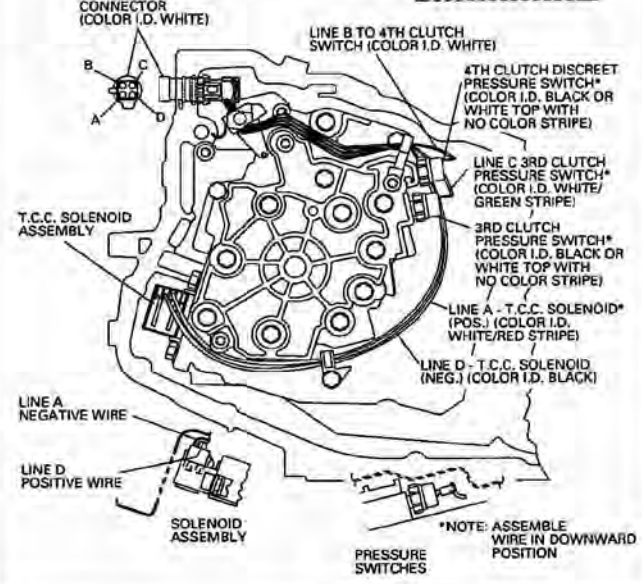
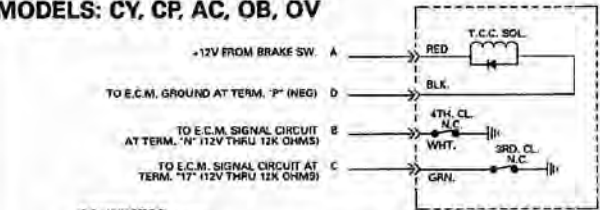

Figure 2
AUTOMATIC TRANSMISSION SERVICE GROUP

1985 MODEL WIRING DIAGRAMS

1985 THM 440-T4 8646249 MODELS: CY, CP, AC, OB, OV



1985 THM 440-T4 8649663 MODEL: AY

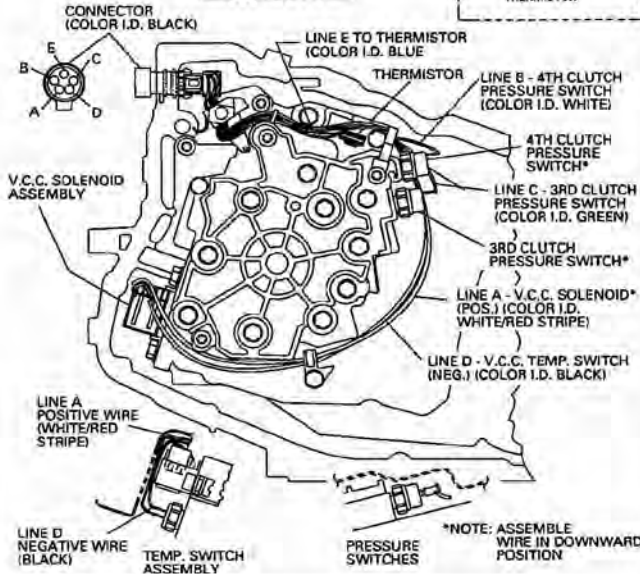
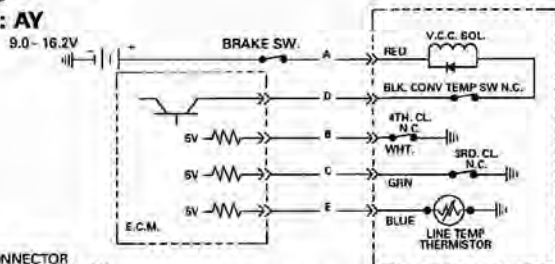

1985 THM 440-T4 8646248 MODELS: BC, BU, BN, BA, BS, CW

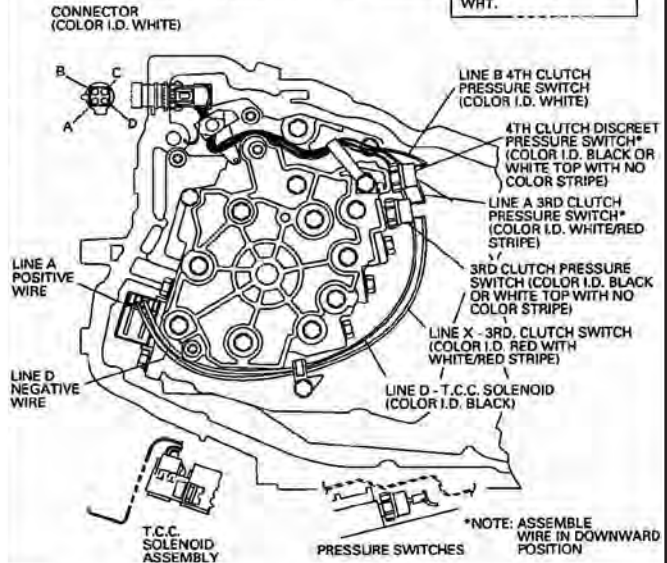
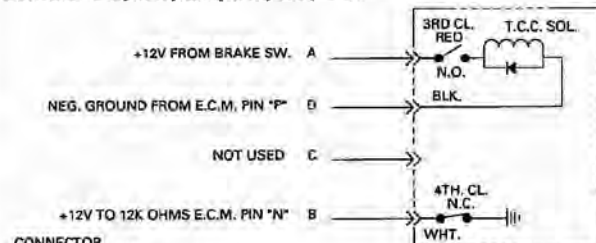
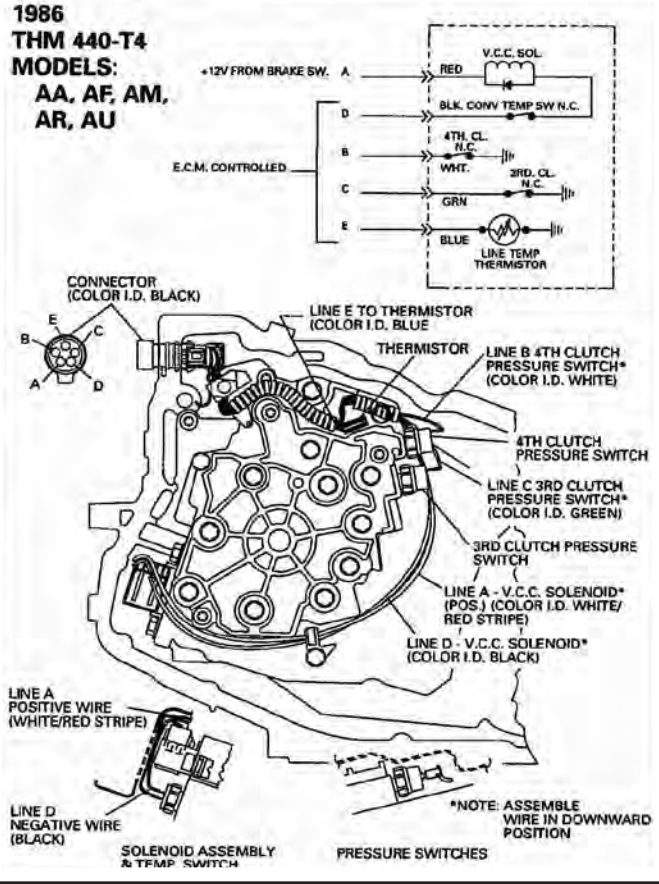

Figure 11

AUTOMATIC TRANSMISSION SERVICE GROUP

1986 MODEL WIRING DIAGRAMS

1986 THM 440-T4 MODELS: AA, AF, AM, AR, AU



1986 THM 440-T4 MODELS: BA BB, BC, BD, BH, BL, BM, BT, BZ, CM, CN

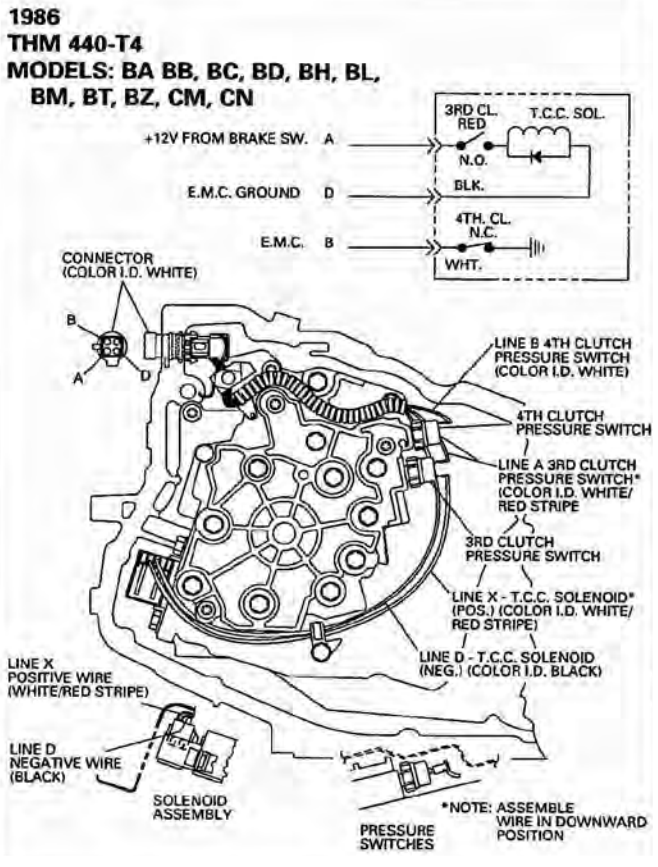

1986 THM 440-T4 MODEL: HJ

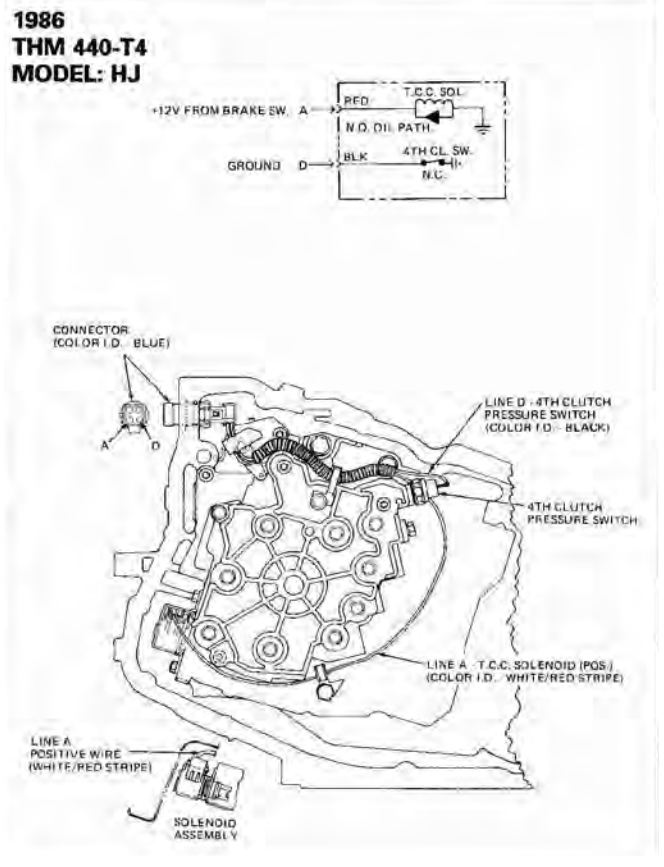
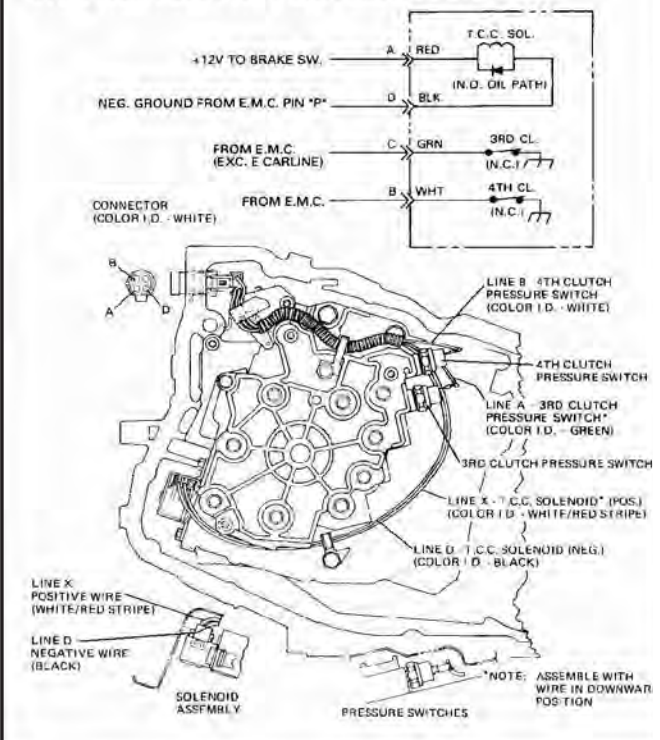

Figure 12

AUTOMATIC TRANSMISSION SERVICE GROUP

1987 MODEL WIRING DIAGRAMS

**1987
THM 440-T4
MODELS: CAH, CBH, FBH, FCH, FJH, FKH, FLH,
FNH, FRH, FSH, FTH, FUH, FZH, HAH, HCH**



**1987
THM 440-T4
MODELS: ACH, AHH,
ALH, ARH**

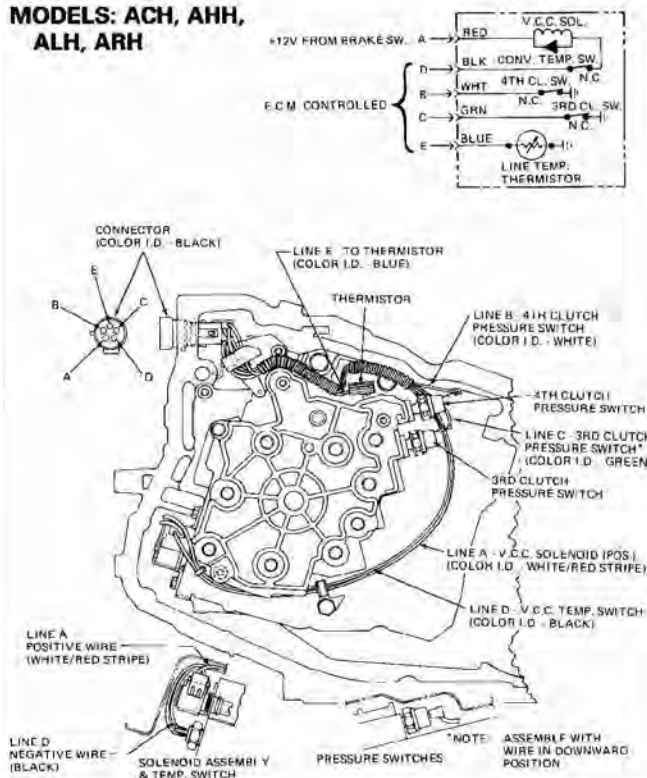

Figure 13

AUTOMATIC TRANSMISSION SERVICE GROUP

1988 MODEL WIRING DIAGRAMS

ProCarManuals.com

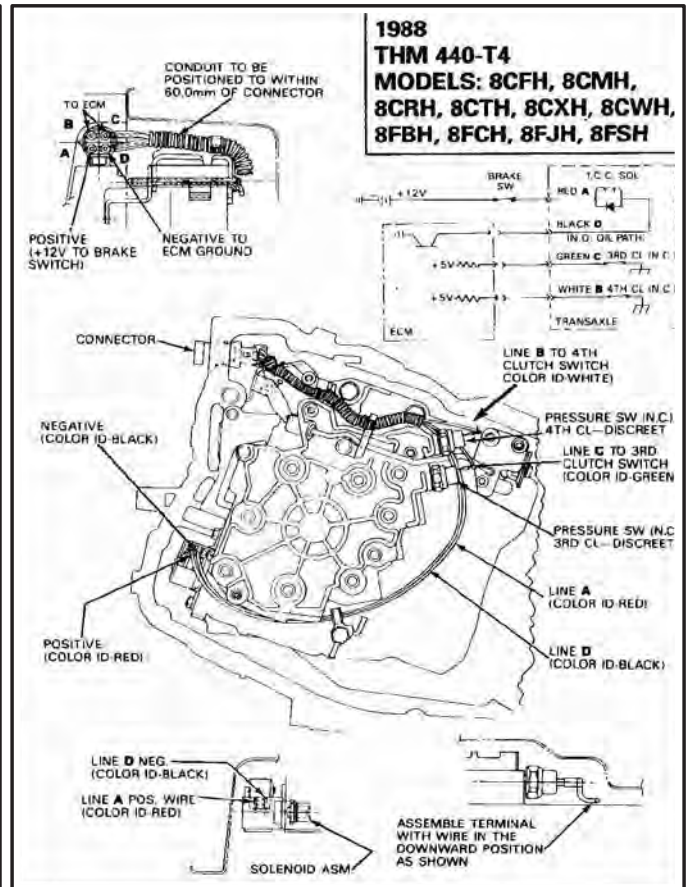
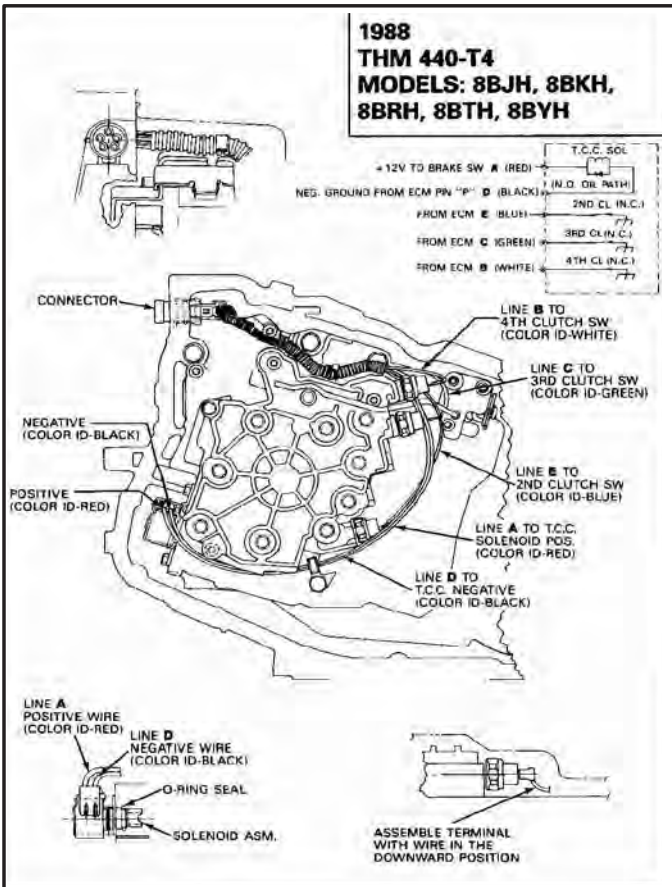
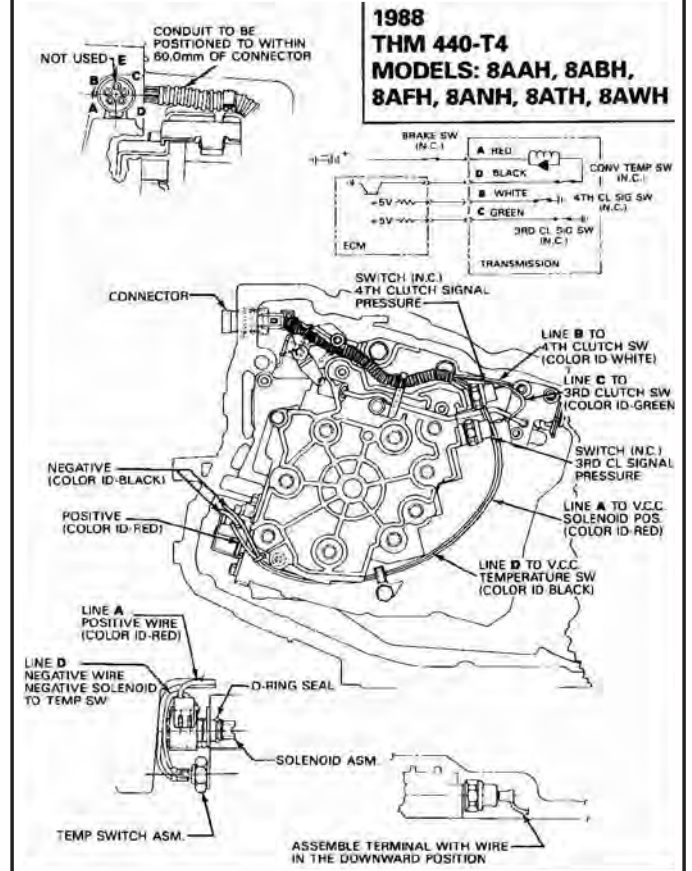

Figure 14

AUTOMATIC TRANSMISSION SERVICE GROUP

1989 MODEL WIRING DIAGRAMS

ProCarManuals.com

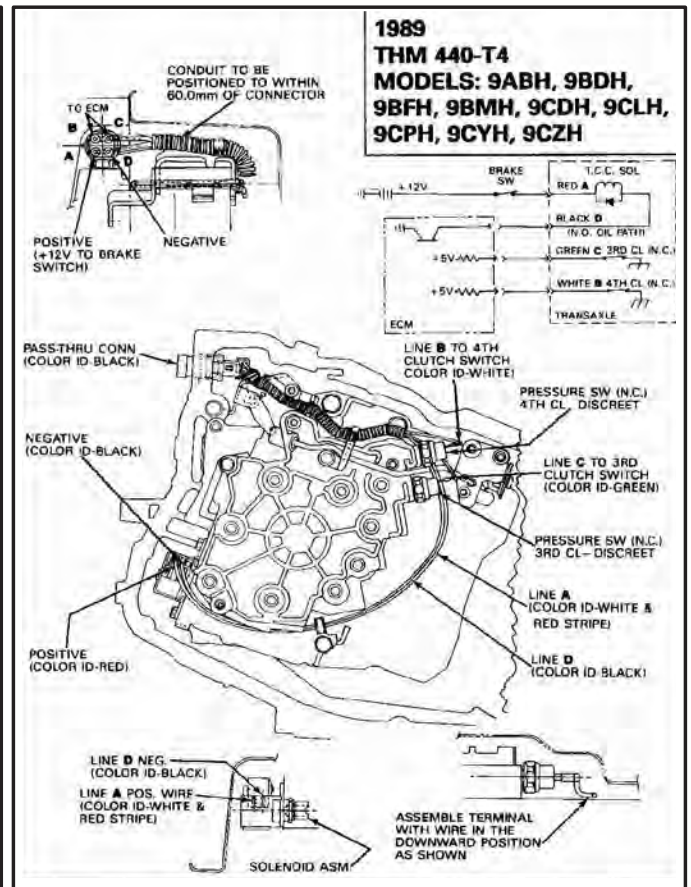
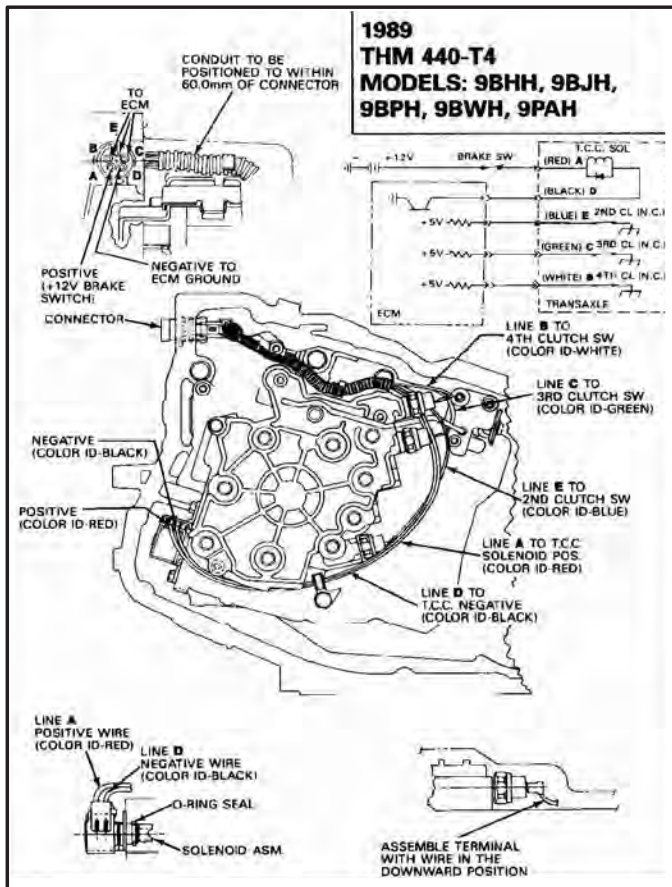
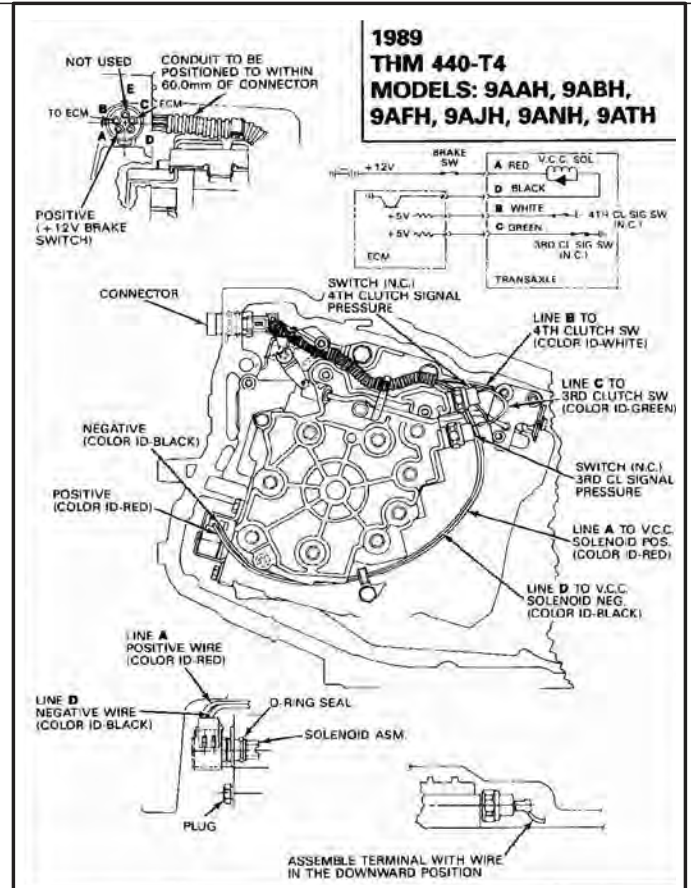

Figure 15

AUTOMATIC TRANSMISSION SERVICE GROUP

1990 MODEL WIRING DIAGRAMS

ProCarManuals.com

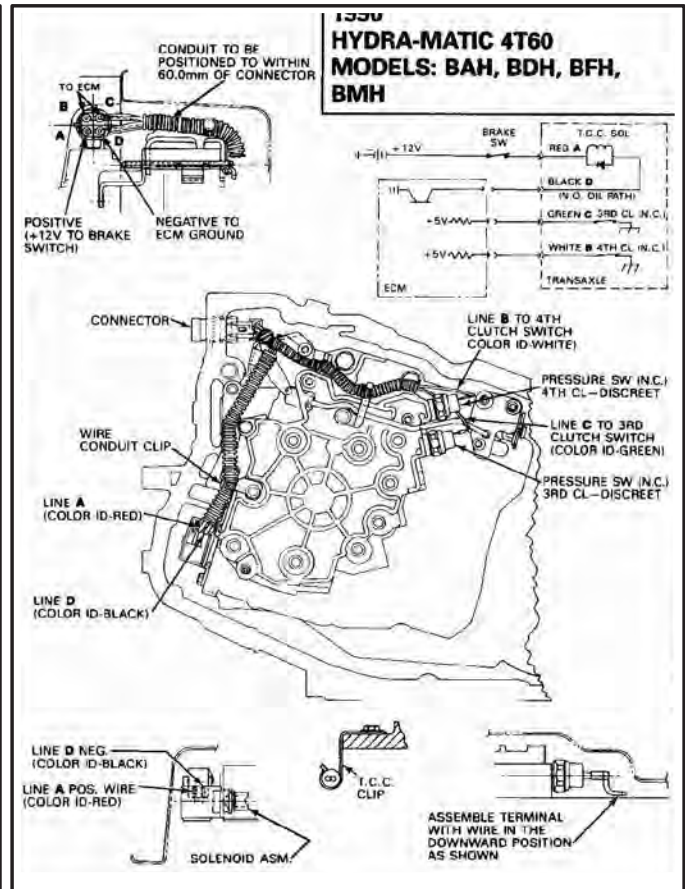
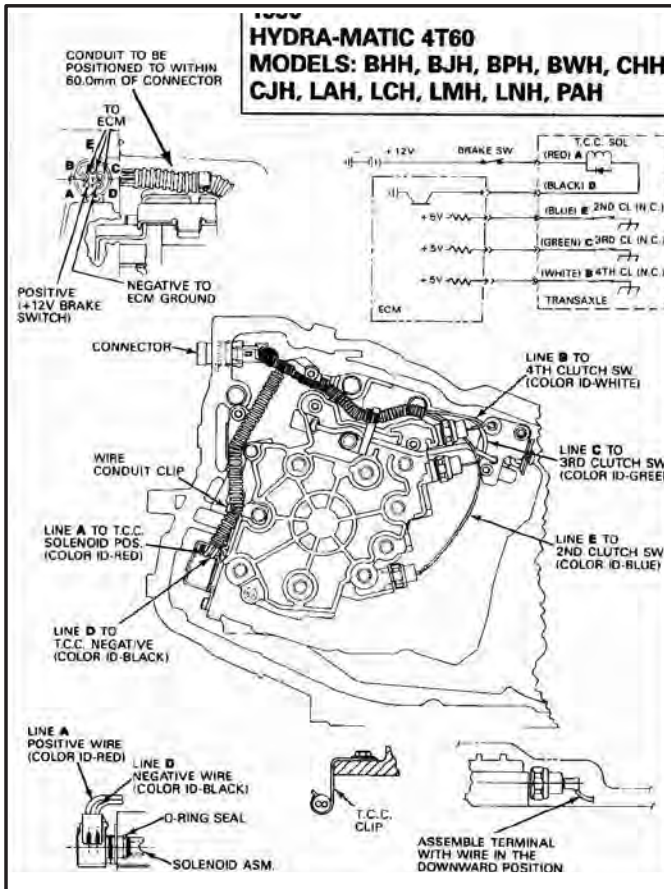
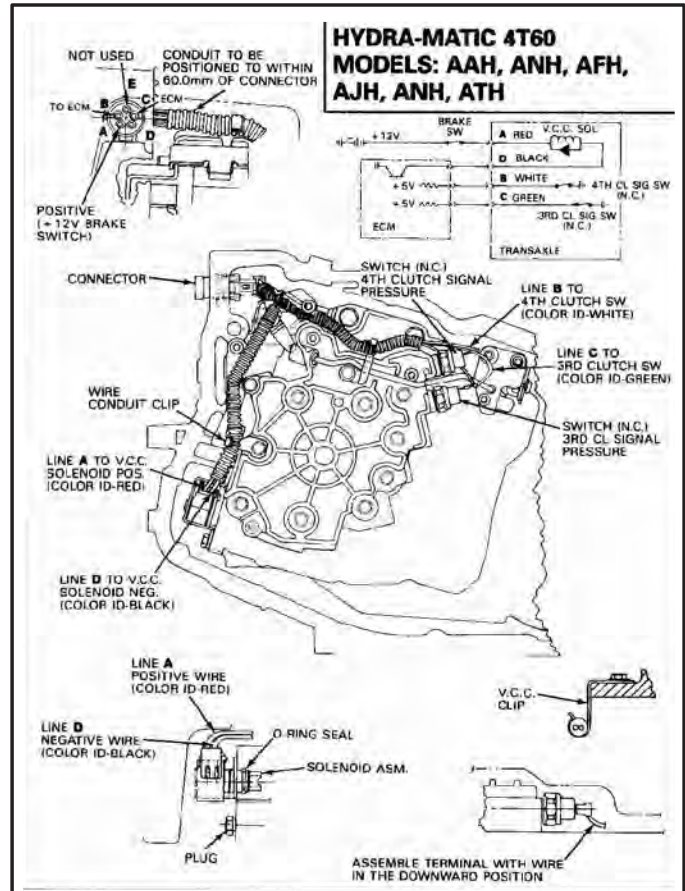

Figure 16

AUTOMATIC TRANSMISSION SERVICE GROUP

1991 MODEL WIRING DIAGRAMS

ProCarManuals.com

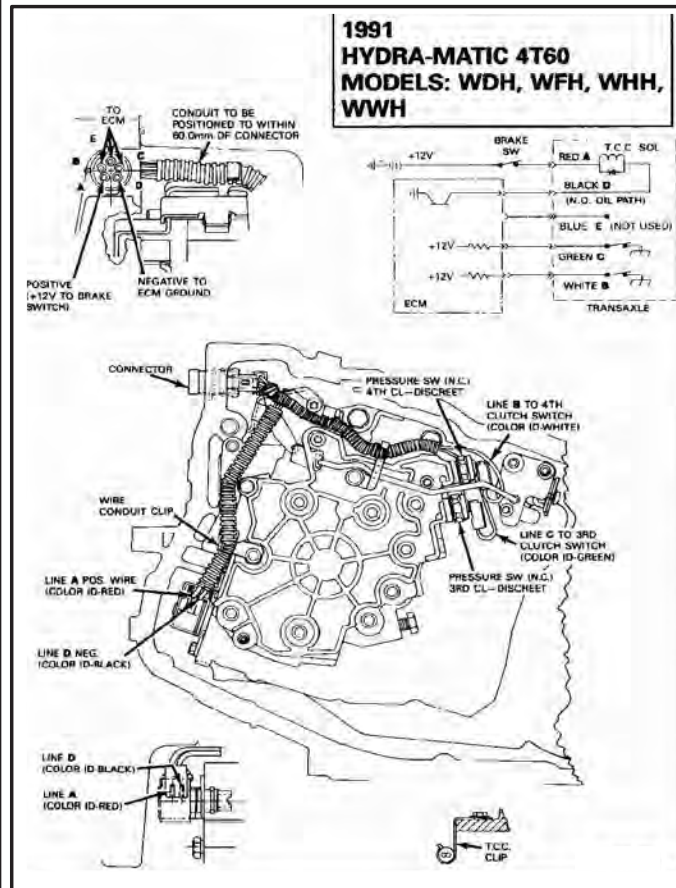
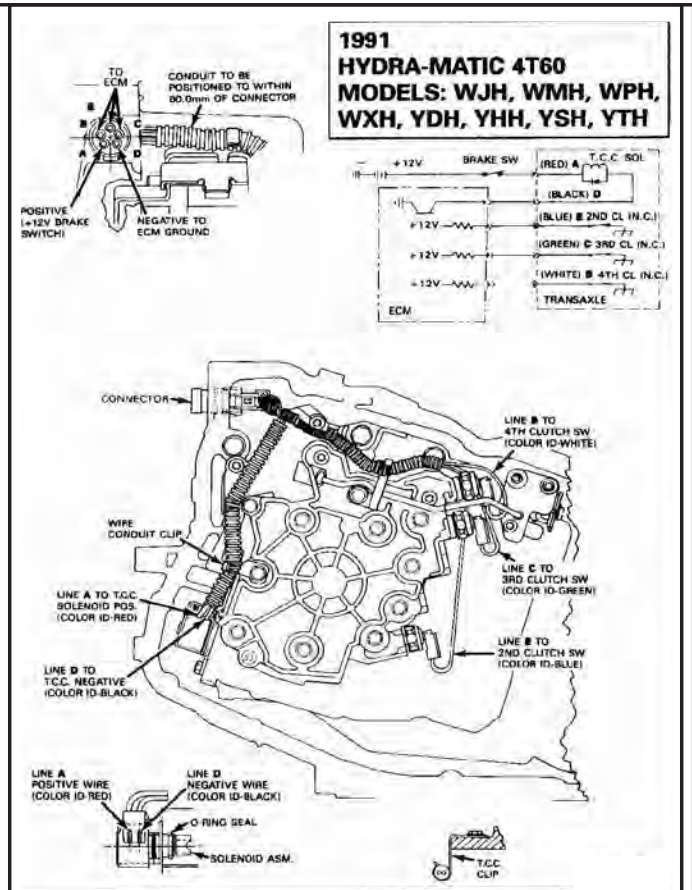
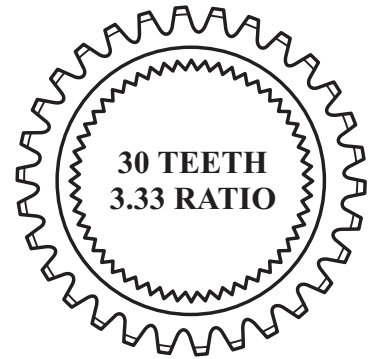

Figure 17

AUTOMATIC TRANSMISSION SERVICE GROUP

"THM 440-T4" FINAL DRIVE RATIO IDENTIFICATION



DIRECTION OF PITCH

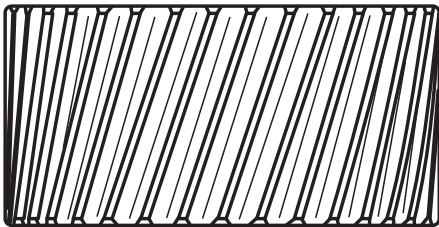

2.84 = 16 Teeth
3.06 = 18 Teeth
3.33 = 20 Teeth

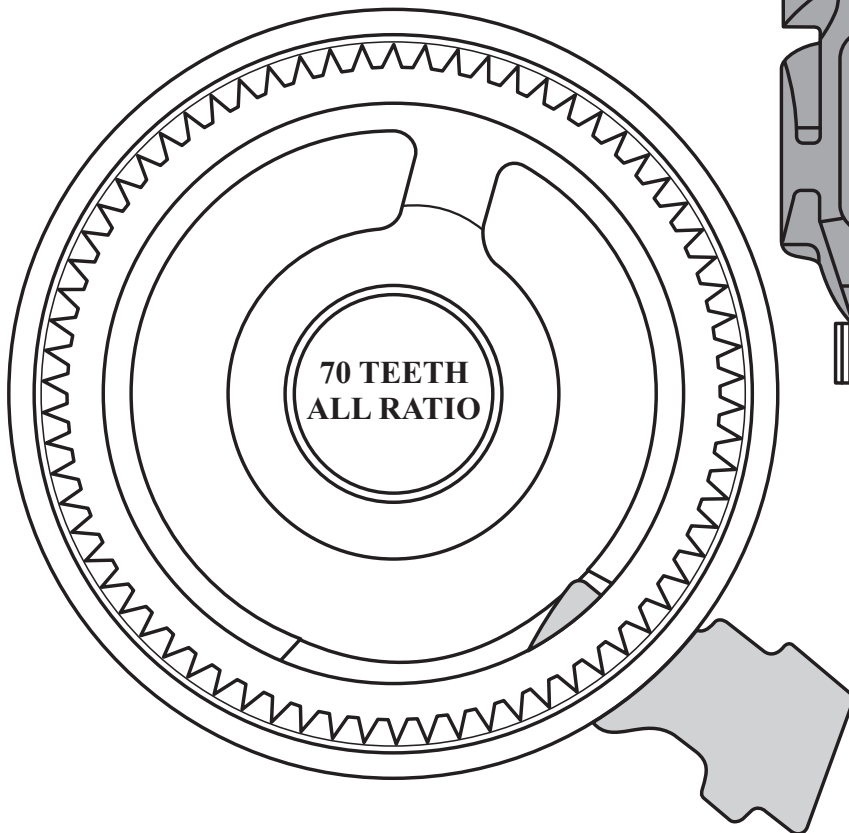
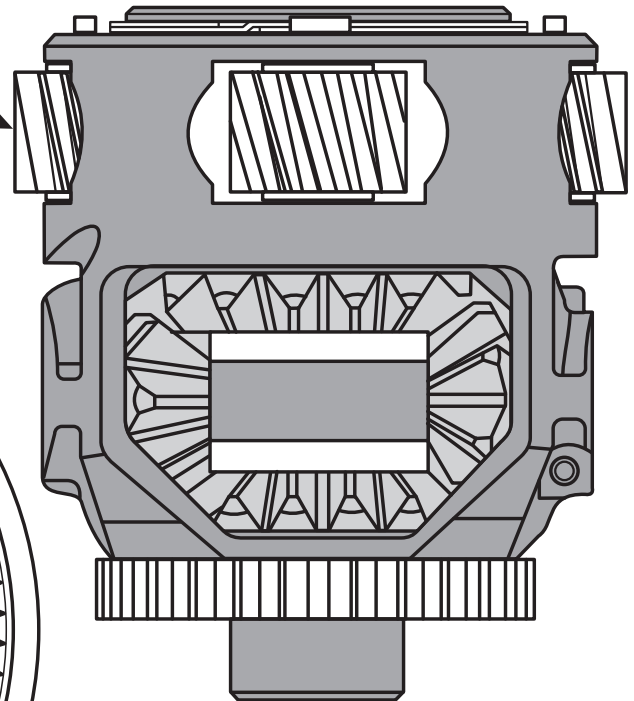
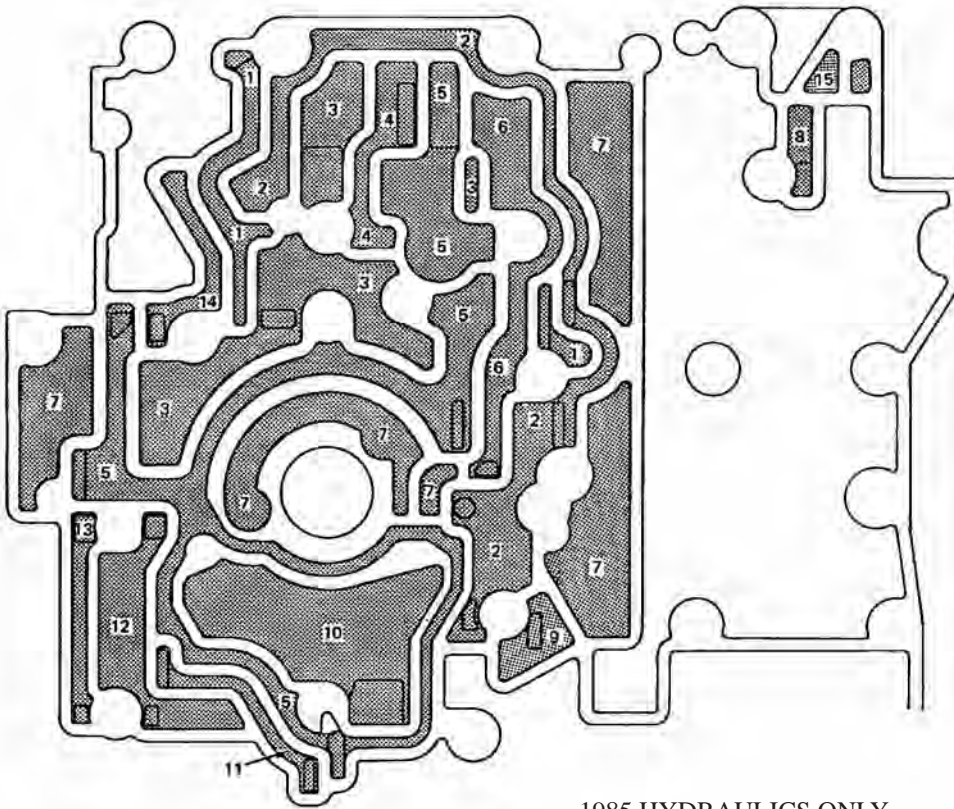
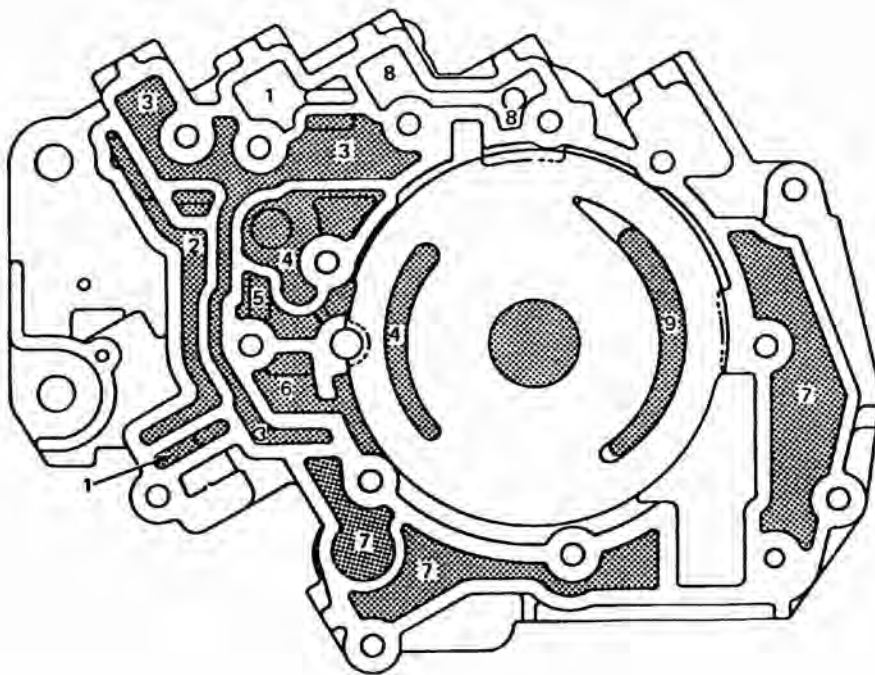

Figure 18



- 1 4TH CLUTCH
- 2 3RD CLUTCH
- 3 EXHAUST
- 4 DECREASE
- 5 LINE PRESSURE
- 6 3RD/3RD EXHAUST
- 7 VOID
- 8 SERVO RELEASE
- 9 2ND CLUTCH
- 10 SUCTION
- 11 REGULATOR APPLY
- 12 CONVERTER FEED
- 13 CONVERTER CLUTCH SIGNAL
- 14 MODULATOR (T.V. ON DIESEL)
- 15 SERVO APPLY

1985 HYDRAULICS ONLY



- 1 3RD CLUTCH
- 2 3RD OR 3RD EXHAUST
- 3 4TH CLUTCH
- 4 LINE PRESSURE
- 5 DECREASE OIL
- 6 EXHAUST
- 7 VOID
- 8 VOID OR GOVERNOR
- 9 SUCTION

1985 HYDRAULICS ONLY

Figure 20
AUTOMATIC TRANSMISSION SERVICE GROUP

OIL PRESSURE TESTING PROCEDURES

PRELIMINARY CHECKS:

- (1) Check for proper transaxle fluid level, and proper fluid color. Normal fluid is red in color.
- (2) Check T.V. Cable and adjust as necessary.
- (3) Check manual linkage and adjust as necessary.
- (4) Check for cracked or broken vacuum lines to the Vacuum Modulator, and replace as necessary.

NOTE: The Vacuum Regulator Valve must be checked for proper operation on Diesel Engine applications before oil pressure test is performed.

- (5) Gasoline engines must be properly tuned for accurate vacuum signals to the vacuum modulator.
- (6) Install Oil Pressure Gage ******(See Figure Below).
- (7) Connect Tachometer to Engine.

CHECK OIL PRESSURES IN THE FOLLOWING MANNER:

MINIMUM LINE PRESSURE CHECK:

With the parking brake and vehicle brakes applied, take the line pressure readings in the ranges and at the engine RPM indicated in the chart below.

MAXIMUM LINE PRESSURE CHECK:

Full line pressure readings are obtained by removing, and capping, the vacuum line from the modulator. Take the line pressure readings in the ranges and at the RPM indicated in the chart below.

CAUTION: Service brakes must be applied at all times, and total test time should not exceed 5 minutes, or transaxle overheating may occur.

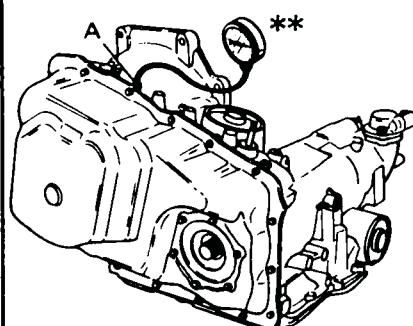

	MODEL	AA, AU		AF, AM, AR, BA, BB, BC, BD, BH, BL, BM, BP, BT, CM, CN, HJ		BZ	
		RANGE	kPa	PSI	kPa	PSI	kPa
TRANSMISSION LINE PRESSURE MINIMUM LINE (1250 R.P.M.)	P, N, D4, D3, D2	422-475	61-69	422-475	61-69	455-511	66-74
	D1	946-1324	137-192	998-1276	145-185	1112-1399	161-203
	REV.	422-475	61-69	422-475	61-69	455-511	66-74
TRANSMISSION LINE PRESSURE FULL LINE (1250 R.P.M.)	N, D4, D3, D2	1030-1266	150-184	1152-1393	167-202	1186-1429	172-207
	D1	946-1324	137-192	998-1276	145-185	1112-1399	161-203
	REV.	1436-1764	209-257	1573-1901	228-276	1619-1951	235-283

A ATTACH OIL PRESSURE GAGE

Line pressure is basically controlled by pump output, and pump output is controlled by the pressure regulator valve and the vacuum modulator. Notice that there is no manual valve boost in reverse (Except Diesel), on this transaxle. Manual valve boost occurs only in Manual Lo. Also, in all selector lever positions (Except Manual Lo), the line pressure should increase with throttle opening, because of the modulator.

Figure 3

AUTOMATIC TRANSMISSION SERVICE GROUP

CONDITION	INSPECT COMPONENT	FOR CAUSE
OIL LEAK	<ul style="list-style-type: none"> • Side Cover (51), Bottom Pan (59) and Gaskets (63, 64 & 65) • T.V. Cable, Fill Tube, and Electrical Connector (23) • Servo Covers (544 & 554) • Governor Cover (9) • Cooler Fittings (526) or Pressure Taps (538 & 529) • Manual Shaft (702) • Axle Seals (540 & 405) • Modulator (19) • Speedo (13) • Parking Plunger Guide (711) • Converter (1) or Converter Seal (541) 	<ul style="list-style-type: none"> — Low attaching screw torque. — Damaged gasket. — Cover distorted. — Seal damage. — Damaged seal (555 or 545). — Porosity in groove. — Damaged "O" ring seal (8). — Low torque, stripped threads. — Damaged seal assembly. — Damaged or garter spring missing. — Damaged "O" ring seal (18). — Damaged "O" ring seal. — Damaged "O" ring seal (712). — Damaged seal assembly, garter spring missing. — Welded seam leaking. — Damaged converter hub.
OIL OUT THE VENT OR FOAMING	<ul style="list-style-type: none"> • Oil Level • Transmission Oil (Foaming) • Oil Filter (Foaming) (58) • Thermo Element (Case) (105) • Modulator Port Gasket (415) • Drive Sprocket Support (517) 	<ul style="list-style-type: none"> — Transaxle overfilled. — Contaminated with antifreeze or engine overheating. — Lube pipes (110 & 142) leaking. — Damaged seal assembly. — Does not close when hot. — Not installed correctly. — Incorrect pin heights. — Not installed correctly or damaged. — Plugged drain back holes.
HIGH OR LOW OIL PRESSURE (VERIFY WITH GAGE ENGINE MUST BE PROPERLY TUNED) ENGINE MUST DEVELOP 13-17 HG. IN. OF VACUUM	<ul style="list-style-type: none"> • Oil Level • Vacuum Line • Aspirator Tee • Modulator (19) • Modulator Valve (17) • Oil Pump Assembly (44) • Pressure Regulator Valve (307) or Spring (364) • Pressure Relief Valve (307) 	<ul style="list-style-type: none"> — High or low; correct as required. — Leaking, pinched, disconnected or cut. — Installed backwards/blocked. — Leaks or damaged diaphragm. — Nicked, scored or stuck. — Slide stuck, seals damaged, vanes damaged. — Pump drive shaft damaged. — Nicked or scored, spring damaged. — Damaged spring, ball missing.

Figure 4

CONDITION	INSPECT COMPONENT	FOR CAUSE
DELAYED ENGAGEMENT	<ul style="list-style-type: none"> • Fluid Level • Cooler Check Ball • Reverse Servo Assembly • 1-2 Servo Assembly 	<ul style="list-style-type: none"> — Low. — Not seating. — Seal cut or damaged. — Seal (557) cut or damaged.
NO DRIVE IN DRIVE RANGE (INSTALL PRESSURE GAGE)	<ul style="list-style-type: none"> • Oil Level • Oil Pressure • Manual Linkage • 1-2 Servo Assembly (558) • Drive Axles • 1-2 Servo Oil Pipes (135 & 136) • Oil Pump Assembly (44) • #13 Check Ball • Torque Converter (1) • Input Clutch Accumulator Piston • Drive Link Assembly (510) • Input Clutch Assembly (626) • Input Sprag (653) and Input Sun Gear Assembly (658) • 3rd Roller Clutch • Input Carrier (662) and Reaction Carrier Assy. (664) • Output Shaft (565) • 1-2 Band Assembly (668) • Parking Pawl • Final Drive Assembly (679) or Final Drive Sun Gear Shaft (669) 	<ul style="list-style-type: none"> — Low (correct). — Low (See Causes of Low Pressure). — Misadjusted or disconnected. — Piston or seal damaged. — Wrong apply pin. — Disengaged. — Leaking oil - seals damaged. — Damaged (See Causes of Low Oil Pressure). — Pump drive shaft damaged. — Off location. — Stator roller clutch (vehicle moves, but is very sluggish). — Converter not bolted to flex plate. — Seal damaged. — Damaged or broken drive link chain. — Sprocket or bearings damaged. — Burned, clutch plates or missing. — Damaged piston seals or piston. — Housing check ball assembly leaking. — Input shaft seals damaged (624). — Input shaft feed passages blocked. — Improper assembly. — Sprag damaged - roll over. — Burned due to lack of lube. (Lube pipe leaking or damaged.) — Pinions damaged. — Internal gear damaged. — Sun gear damaged. — Damaged, misassembled with axles. — Burned. — Band mislocated. — Spring broken. — Damaged side gear, gears, pinion, internal gear.

Figure 5

CONDITION	INSPECT COMPONENT	FOR CAUSE
SLIPS IN DRIVE	<ul style="list-style-type: none"> • Fluid Level • Vacuum Line • Modulator • Oil Pressure • Modulator Valve • 1-2 Servo Assembly • 1-2 Servo Piston • Screen • Servo Pipe or Seals • Torque Converter • Input Clutch Accumulator Piston • Input Clutch Assy. (626) 	<ul style="list-style-type: none"> – Low - correct. – Pinched or cut. – Damaged. – See Causes of Low Pressure. – Stuck or binding. – Damaged. – Seal damaged. – Plugged. – Leaking, or damaged seals. – Stator roller clutch not holding. – Input shaft seals damaged (624). – Leaks at ball capsule (625) or seals. – Seal damaged (419).
FIRST SPEED ONLY NO 1-2 SHIFT	<ul style="list-style-type: none"> • T.V. System • Governor Assembly (5) • Governor Pipes (125 & 124) • Accumulator Cover (121), Retainer (129) and Pipes • Control Valve Assy. (35) • Driven Sprocket Support (604) • 2nd Clutch Assy. (611) • Reverse Reaction Drum 	<ul style="list-style-type: none"> – Thrust bearing damaged. – Weights binding. – Springs damaged. – Gear damaged. – Seal leaking. – Exhaust check balls missing or damaged, not seated. – Leaks. – Accumulator cover leaking. – Governor screen blocked. – Orifice cup plug blocked. – Governor retainer leaking. – 1-2 Shift valve stuck or binding. – Spacer plate or gaskets mispositioned or damaged. – Oil seal rings damaged. – Clutch plates damaged. – Piston or seals damaged. – Parts misassembled. – Housing check ball assembly damaged. – Splines damaged (missing reverse reaction drum plate).
1-2 SHIFT FEEL – HARSH OR SOFT	<ul style="list-style-type: none"> • Oil Pressure • Accumulator Piston (114 & 118) and Cover (121) 	<ul style="list-style-type: none"> – (See Causes of High or Low Oil Pressure.) – Cover bolts improperly torqued. – Pistons or seals damaged. – Springs damaged. – Gaskets mispositioned, damaged.

Figure 6

CONDITION	INSPECT COMPONENT	FOR CAUSE
1-2 SHIFT FEEL — HARSH OR SOFT (Continued)	<ul style="list-style-type: none"> • Control Valve Assy. (35) • #8 Check Ball 	<ul style="list-style-type: none"> — Accumulator valve stuck. — Mislocated.
1-2 SHIFT SPEED — HIGH OR LOW	<ul style="list-style-type: none"> • T.V. Cable • Governor Pressure • T.V. Link (49) or T.V. Lever and Bracket Assy. (50) • T.V. Valve (311) and Plunger 	<ul style="list-style-type: none"> — Disconnected or misadjusted. — (See No 1-2 Shift.) — Bent or damaged. — Stuck or binding.
NO 2-3 SHIFT (1st & 2nd SPEEDS ONLY)	<ul style="list-style-type: none"> • Governor Assembly (5) • 1-2 Servo Assembly (558) • Accumulator Cover • Lube Pipe (110) • Control Valve Assy. (35) • 1-2 Servo Release Pipe (135) • Channel Plate Gasket • Driven Sprocket Support (604) • Input Housing and Shaft Assembly • 3rd Clutch Assembly (633) • 3rd Roller Clutch Assembly 	<ul style="list-style-type: none"> — (See No 1-2 Shift.) — Servo bore orifice cup plug missing (534). — Servo release ball capsule leaking/stuck. — Lube hole blocked. — Leaking or damaged. — 2-3 Shift valve stuck. — #11 Check ball not seating. — Bolts not properly torqued. — #6 Check ball. — #5 Check ball. — 2-3 Accumulator valve stuck. — Leaks - seals damaged. — Mispositioned. — Blocked lube passage. — Seals damaged. — Blocked oil passages. — Clutch plates burned. — Damaged piston or seals. — Damaged check ball assembly (piston). — Damaged cage. — Rollers out of cage. — Damaged springs. — Misassembled on input sun gear shaft.
2-3 SHIFT FEEL — HARSH OR SOFT	<ul style="list-style-type: none"> • See Causes of High or Low Oil Pressure • 1-2 Servo Assembly (558) • 1-2 Servo Release Pipe (135) • #12 Check Ball 	<ul style="list-style-type: none"> — #7 Check ball and capsule assembly leaks. — Leaks - seals damaged. — Mislocated.
2-3 SHIFT SPEED — HIGH OR LOW	<ul style="list-style-type: none"> • See 1-2 Shift Speed 	

Figure 7

CONDITION	INSPECT COMPONENT	FOR CAUSE
NO 3-4 SHIFT	<ul style="list-style-type: none"> • T.V. Adjustment • Governor Assembly (5) • Governor Feed or Return Pipes (124 & 125) • Control Valve Assembly (35) • 4th Clutch Shaft (505) • 4th Clutch Assy. (501) 	<ul style="list-style-type: none"> — (See No 1-2 Shift.) — Leaking. — 3-4 Shift valve stuck. — Spline damage. — Clutch plates burned. — Piston or seals damaged. — Clutch plates or piston mislocated.
3-4 SHIFT FEEL — HARSH OR SOFT	<ul style="list-style-type: none"> • See Causes of High or Low Oil Pressure • Accumulator Cover and Pistons • #1 Check Ball 	<ul style="list-style-type: none"> — Damaged seal. — Improper bolt torque. — Mislocated.
3-4 SHIFT SPEED — HIGH OR LOW	<ul style="list-style-type: none"> • See 1-2 Shift Speed 	
NO CONVERTER CLUTCH APPLY (VEHICLES EQUIPPED WITH E.C.M.)	<ul style="list-style-type: none"> • Verify Proper E.C.M. Operation and Vehicle Wiring • Transaxle Electrical System (48) • Control Valve Assy. (35) • Solenoid Screen (33) • Torque Converter • Turbine Shaft (513) • Oil Pump Drive Shaft (29) • Channel Plate (24) 	<ul style="list-style-type: none"> — Connector damaged. — Pinched wires. — 3rd Clutch switch inoperative. — Solenoid inoperative. — Converter clutch shift valve stuck. — Converter clutch apply valve stuck. — #10 Check ball missing. — Solenoid "O" ring leaking. — Blocked. — Inspect — Seals damaged. — Damaged seal. — Converter clutch blow off check ball not seated or damaged.
NO CONVERTER CLUTCH APPLY (VEHICLES NOT EQUIPPED WITH E.C.M.)	<ul style="list-style-type: none"> • Transaxle Electrical System (48) • Control Valve Assy. (35) • Solenoid Screen (33) 	<ul style="list-style-type: none"> — Connector damaged. — Pinched wires. — 3rd Clutch switch inoperative. — 4th Clutch switch inoperative. — Solenoid inoperative. — Converter clutch shift valve stuck. — Converter clutch apply valve stuck. — #10 Check ball missing. — Blocked.

Figure 8

CONDITION	INSPECT COMPONENT	FOR CAUSE
NO CONVERTER CLUTCH APPLY (VEHICLES NOT EQUIPPED WITH E.C.M.) (Continued)	<ul style="list-style-type: none"> • Torque Converter • Turbine Shaft (513) • Oil Pump Drive Shaft (29) • Channel Plate (24) 	<ul style="list-style-type: none"> – Inspect – Seals damaged. – Damaged seal. – Converter clutch blow off check ball not seating or damaged. – T.C.C. accumulator piston or seal damaged.
CONVERTER CLUTCH DOES NOT RELEASE	<ul style="list-style-type: none"> • E.C.M. • Control Valve Assy. (35) 	<ul style="list-style-type: none"> – Solenoid (328) does not exhaust. – Converter clutch apply valve stuck in apply position.
T.C.C. APPLY, ROUGH, SLIPS, OR SHUDDERS	<ul style="list-style-type: none"> • Control Valve Assy. (35) • Turbine Shaft (513) • Channel Plate (24) 	<ul style="list-style-type: none"> – Converter clutch regulator valve stuck. – Seals damaged or missing. – Converter clutch blow off check ball not seated or damaged. – Converter clutch accumulator piston or seal damaged. – Spring damaged. – Wrong T.C.C. blow off spring. – Seals damaged or missing.
4-3 DOWNSHIFT – HARSH	<ul style="list-style-type: none"> • Control Valve Assy. (35) 	<ul style="list-style-type: none"> – #1 Check ball missing.
3-2 DOWNSHIFT – HARSH	<ul style="list-style-type: none"> • Modulator or Lines • Control Valve Assy. (35) 	<ul style="list-style-type: none"> – Loss of vacuum. – 1-2 Servo control valve stuck. – #12 Check ball missing. – 3-2 Control valve stuck. – #4 Check ball missing. – 3-2 Coast valve stuck. – #2 Check ball missing or mislocated.
2-1 DOWNSHIFT – HARSH	<ul style="list-style-type: none"> • Control Valve Assy. (35) 	<ul style="list-style-type: none"> – #8 Check ball missing. – #2 Check ball missing or mislocated.
NO REVERSE	<ul style="list-style-type: none"> • Oil Pressure (See Causes of High or Low Pressure) • Reverse Servo (548) • Oil Pump Assembly (44) (See No Drive) • Input Clutch Accum. Piston • Drive Link Assy. (510) (See No Drive) • Reverse Band (609) 	<ul style="list-style-type: none"> – Misassembled. – Piston or seal damaged. – Wrong apply pin. – Seal damaged. – Burned, damaged, or mislocated.

Figure 9

CONDITION	INSPECT COMPONENT	FOR CAUSE
NO REVERSE (Continued)	<ul style="list-style-type: none"> • Input Clutch (626) (See No Drive) • Reverse Reaction Drum (659) • Input Sprag (653) (See No Drive) • Input and Reaction Carriers (662 & 664) (See No Drive) 	<ul style="list-style-type: none"> – Splines damaged. – (See No Drive.)
SLIPS IN REVERSE (ALSO SEE SLIPS IN DRIVE)	<ul style="list-style-type: none"> • Oil Pressure • Reverse Servo • Reverse Reaction Drum (659) 	<ul style="list-style-type: none"> – See Causes of Low Pressure. – Damaged seal. – Damaged splines.
NO PARK RANGE	<ul style="list-style-type: none"> • Manual Linkage (401) • Final Drive Internal Gear (673) • Actuator Assembly 	<ul style="list-style-type: none"> – Damaged or disconnected. – Park pawl spring. – Park pawl. – Parking gear. – Spring damaged.
HARSH NEUTRAL TO REVERSE OR HARSH NEUTRAL TO DRIVE	<ul style="list-style-type: none"> • Modulator, Aspirator Tee, and/or Lines • Control Valve Assy. (35) • Spacer Plate (31) 	<ul style="list-style-type: none"> – Loss of vacuum due to damaged lines or modulator. – Aspirator tee backwards/plugged. – #9 Check ball missing - results in harsh reverse. – #12 Check ball missing - results in harsh drive. – Thermal element does not close when warm.
NO VISCOUS CLUTCH APPLY (VEHICLES EQUIPPED WITH E.C.M.)	<ul style="list-style-type: none"> • Verify Proper E.C.M. Operation 	<ul style="list-style-type: none"> – Temperature switch (426) damaged. – See Causes of No T.C.C. Apply.
2nd GEAR STARTS	<ul style="list-style-type: none"> • Modulator System • Control Valve Assembly 	<ul style="list-style-type: none"> – Oil pressure high (See Causes of High Line Pressure. – Stuck 1-2 shift valve.

Figure 10

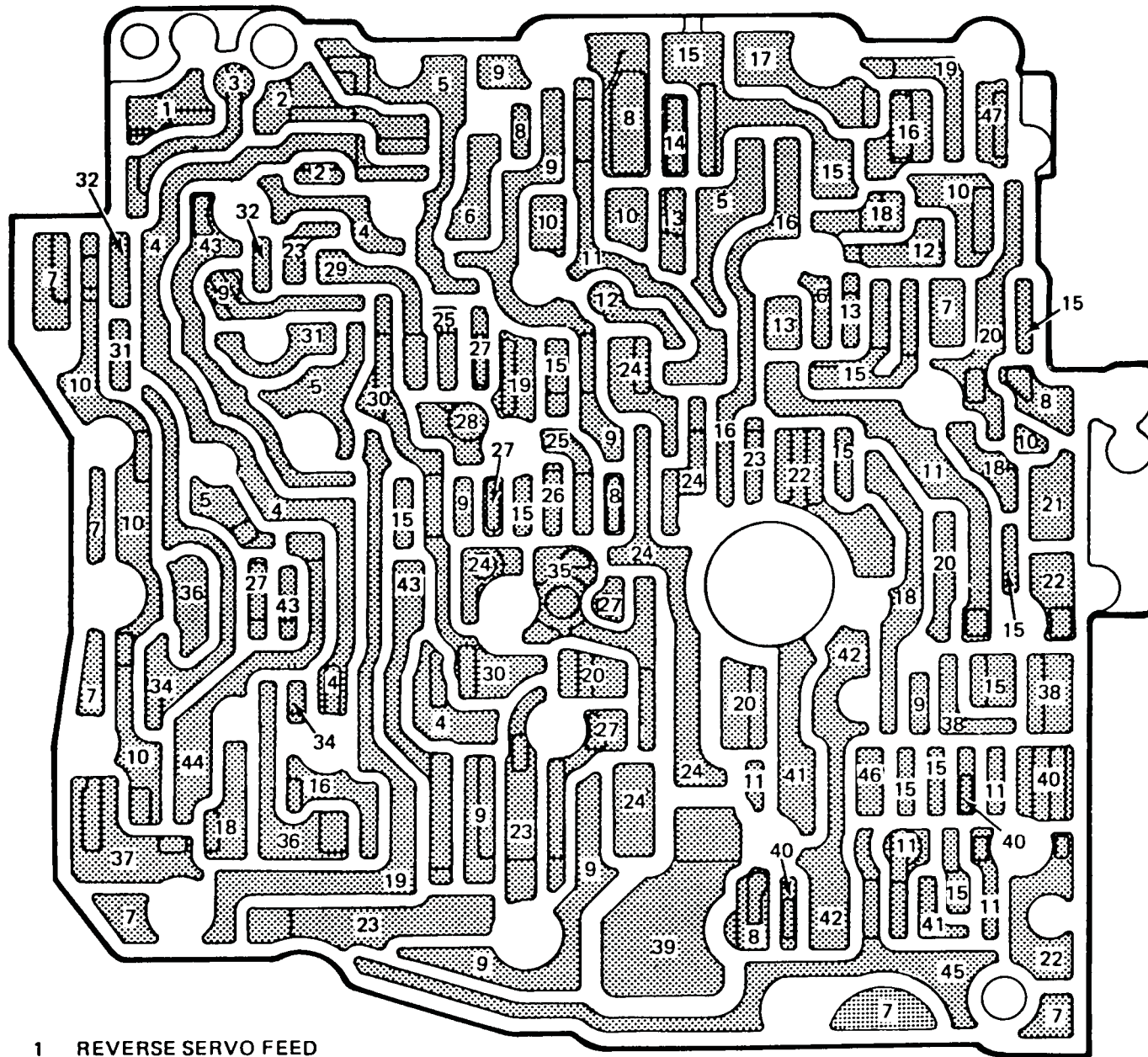

- | | | | | | |
|----|--------------------|----|---------------------------|----|-----------------------|
| 1 | REVERSE SERVO FEED | 19 | 4TH CLUTCH | 35 | 3RD/3RD EXHAUST |
| 2 | 1-2 SERVO FEED | 20 | MODULATOR | 36 | LO-1ST |
| 3 | REVERSE | 21 | T.V. (OPTIONAL MODULATOR) | 37 | T.V./DETENT |
| 4 | 1-2 SERVO | 22 | CONVERTER CLUTCH SIGNAL | 38 | 1-2 ACCUMULATOR |
| 5 | DRIVE 2 | 23 | 2ND CLUTCH | 39 | SUCTION |
| 6 | PRND432 | 24 | GOVERNOR | 40 | REGULATOR APPLY |
| 7 | VOID | 25 | INPUT CLUTCH FEED | 41 | RELEASE |
| 8 | LINE | 26 | DRIVE 3 | 42 | APPLY |
| 9 | DRIVE 4 | 27 | 3RD CLUTCH | 43 | 1-2 SERVO RELEASE |
| 10 | T.V. | 28 | 4TH/4TH EXHAUST | 44 | DETENT/3-2 DOWN |
| 11 | CONVERTER FEED | 29 | INPUT CLUTCH | 45 | COOLER |
| 12 | PART THROTTLE | 30 | 2-3 ACCUMULATOR EXHAUST | 46 | EXHAUST/T.V. DIESEL |
| 13 | T.V. FEED | 31 | PT./D3 | 47 | DET./MOD.-MOD. DIESEL |
| 14 | DECREASE | 32 | 4-3 MODULATOR | | |
| 15 | EXHAUST | 33 | SERVO RELEASE | | |
| 16 | LO | 34 | 3-4 MODULATOR | | |
| 17 | PRN | | | | |
| 18 | DETENT | | | | |

1985 HYDRAULICS ONLY

Figure 21

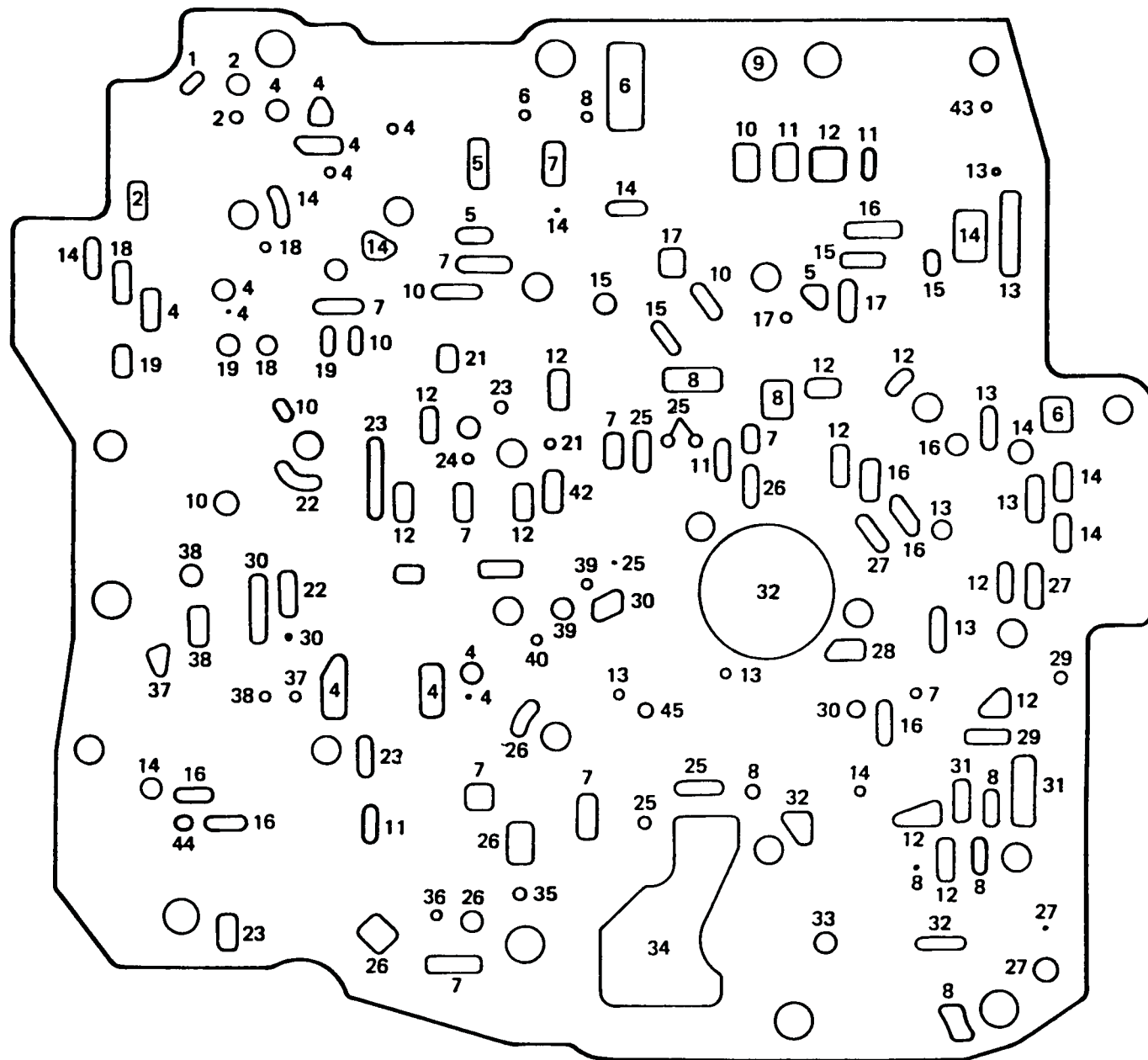

1985 HYDRAULICS ONLY		
1	REVERSE SERVO FEED	
2	REVERSE	
3	1-2 SERVO FEED	
4	1-2 SERVO	
5	PRND432	
6	LINE	
7	DRIVE 4	
8	CONVERTER FEED	
9	PRN	
10	DRIVE 2	
11	LO	
12	EXHAUST	
13	MODULATOR	
14	T.V.	
15	PART THROTTLE	
16	DETENT	
17	T.V. FEED	
18	4-3 MODULATOR	
19	PT./D3	
20	INPUT CLUTCH	
21	INPUT CLUTCH FEED	
22	1-2 SERVO RELEASE	
23	4TH CLUTCH	
24	4TH CLUTCH FEED	
25	GOVERNOR	
26	2ND CLUTCH	
27	CONVERTER CLUTCH SIGNAL	
28	APPLY	
29	1-2 ACCUMULATOR	
30	3RD CLUTCH	
31	REGULATOR APPLY	
32	RELEASE	
33	RELEASE OR APPLY	
34	SUCTION	
35	2ND EXHAUST	
36	2ND CLUTCH FEED	
37	3-4 MODULATOR	
38	LO-1ST	
39	3RD CLUTCH EXHAUST	
40	3RD CLUTCH FEED	
41	2-3 ACCUMULATOR EXHAUST	
42	DRIVE 3	
43	DETENT/MODULATOR	
44	3-2 DOWNSHIFT	
45	3RD/3RD CLUTCH EXHAUST	

Figure 22

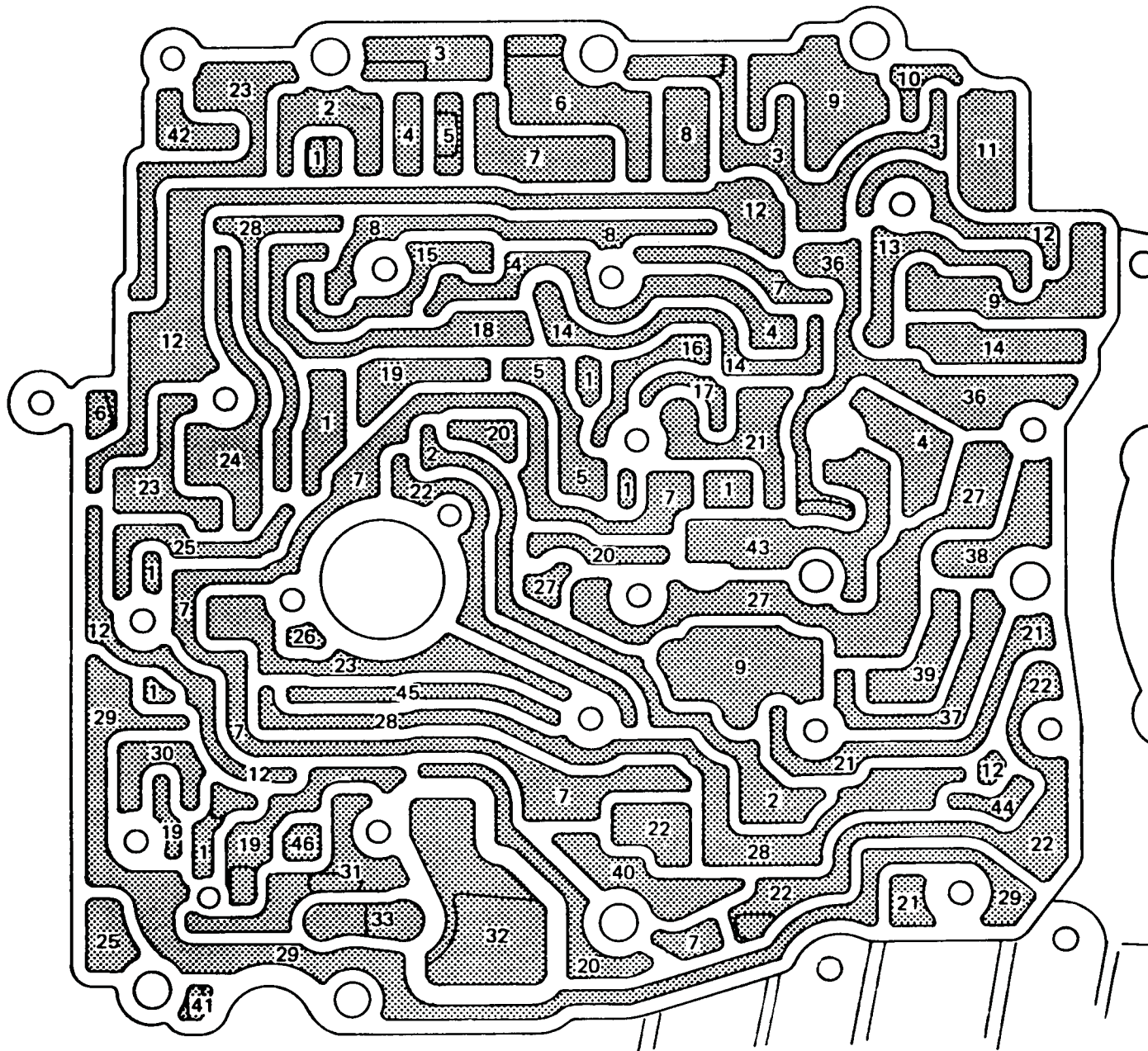

- | | | |
|-----------------------------|--|----------------------------|
| 1 EXHAUST | 17 4TH OR 4TH EXHAUST | 32 SUCTION |
| 2 LO | 18 PART THROTTLE | 33 RELEASE OR APPLY |
| 3 PRN | 19 CONVERTER FEED | 34 2-3 ACCUMULATOR EXHAUST |
| 4 DRIVE 2 | 20 GOVERNOR | 35 SERVO RELEASE |
| 5 DRIVE 3 | 21 4TH CLUTCH | 36 INPUT CLUTCH OR REVERSE |
| 6 LINE | 22 2ND CLUTCH | 37 3-4 MODULATOR |
| 7 DRIVE 4 | 23 MODULATOR | 38 3RD CLUTCH/LO-1ST |
| 8 PRND432 | 24 DETENT (OPT. EXHAUST
OR PART THROTTLE) | 39 LO-1ST |
| 9 1-2 SERVO | 25 CONVERTER CLUTCH SIGNAL | 40 2ND OR 2ND EXHAUST |
| 10 REVERSE SERVO FEED | 26 APPLY | 41 COOLER |
| 11 REVERSE | 27 3RD CLUTCH | 42 DETENT/MODULATOR |
| 12 T.V. | 28 DETENT | 43 1-2 SERVO RELEASE |
| 13 4-3 MODULATOR | 29 1-2 ACCUMULATOR | 44 3-2 DOWNSHIFT |
| 14 PART THROTTLE OR DRIVE 3 | 30 REGULATOR APPLY | 45 3RD CL./3RD CL. EXHAUST |
| 15 T.V. FEED | 31 RELEASE | 46 VOID |
| 16 INPUT CLUTCH FEED | | |

1985 HYDRAULICS ONLY

Figure 23

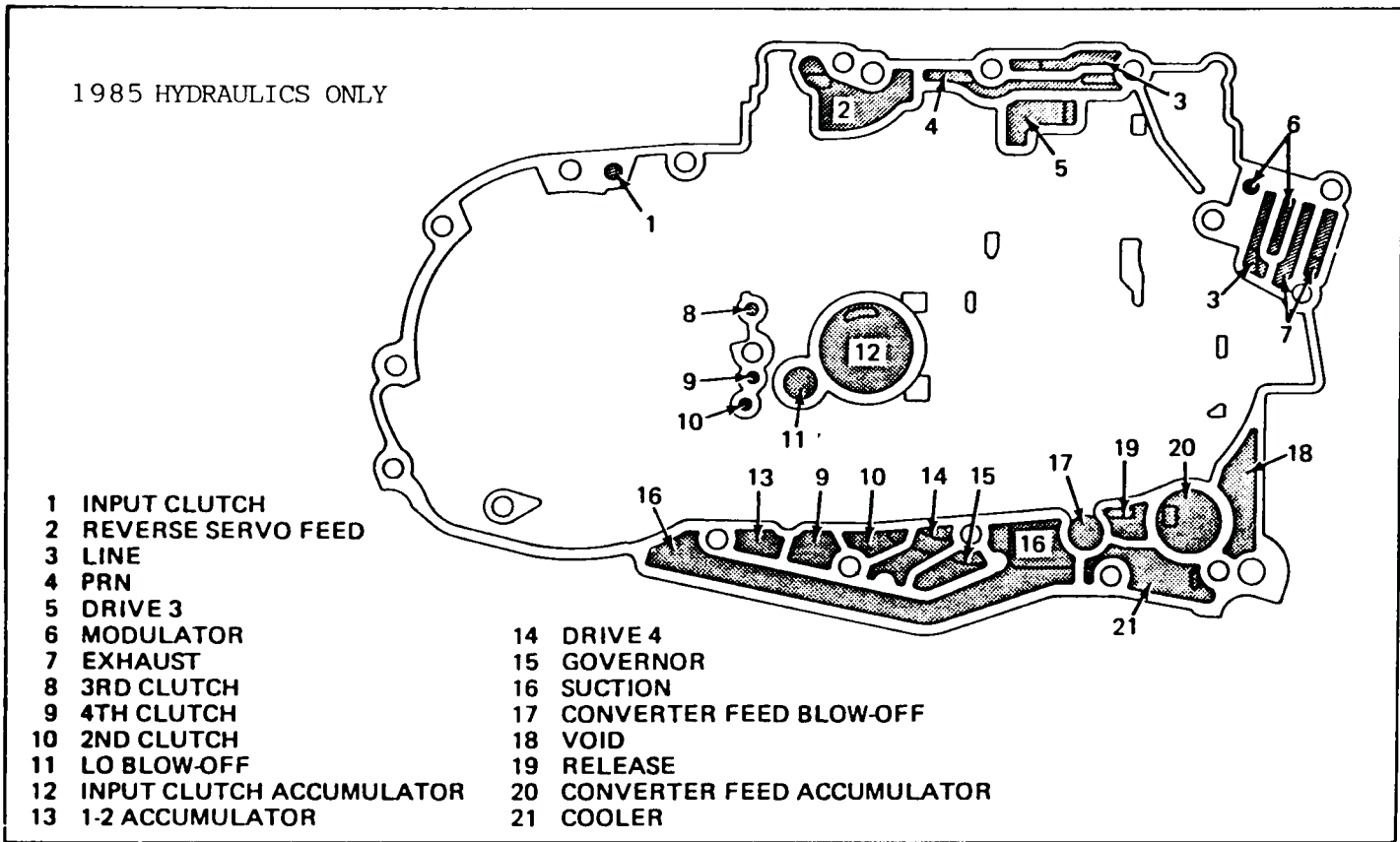

Figure 24

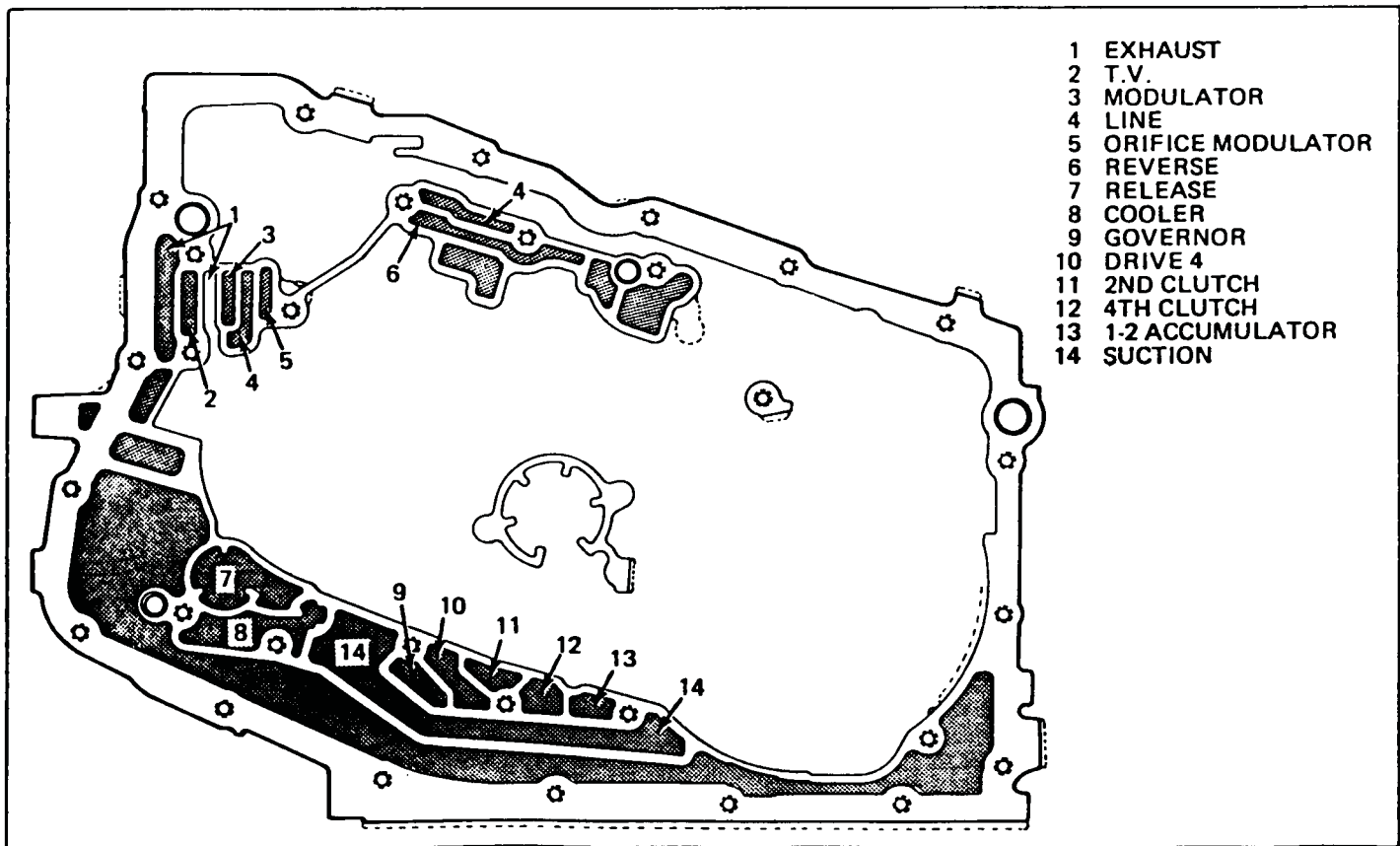

Figure 25

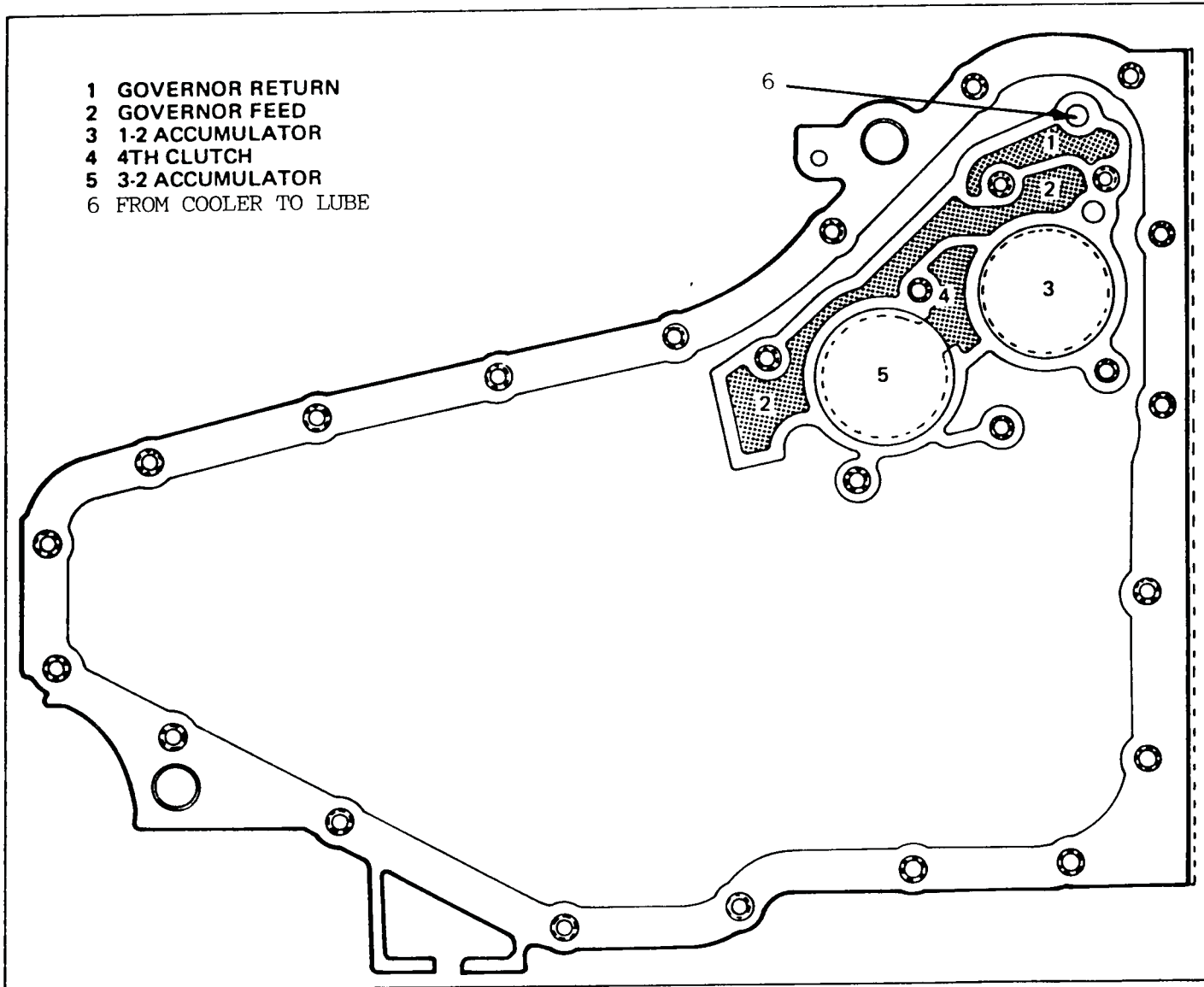
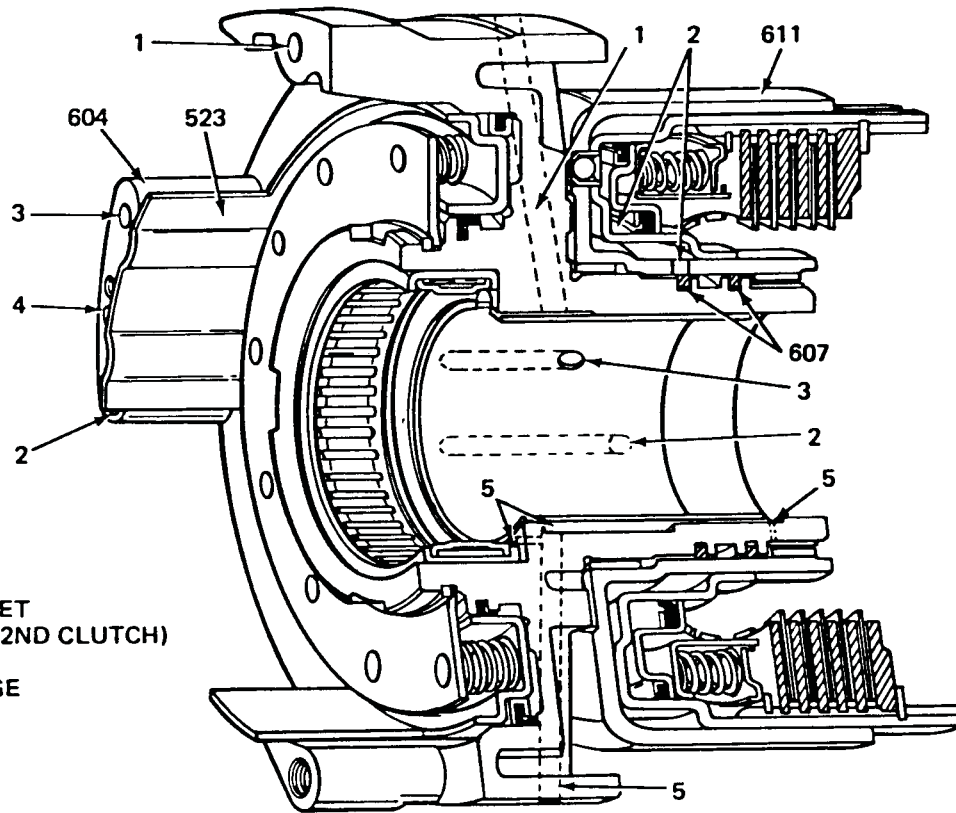
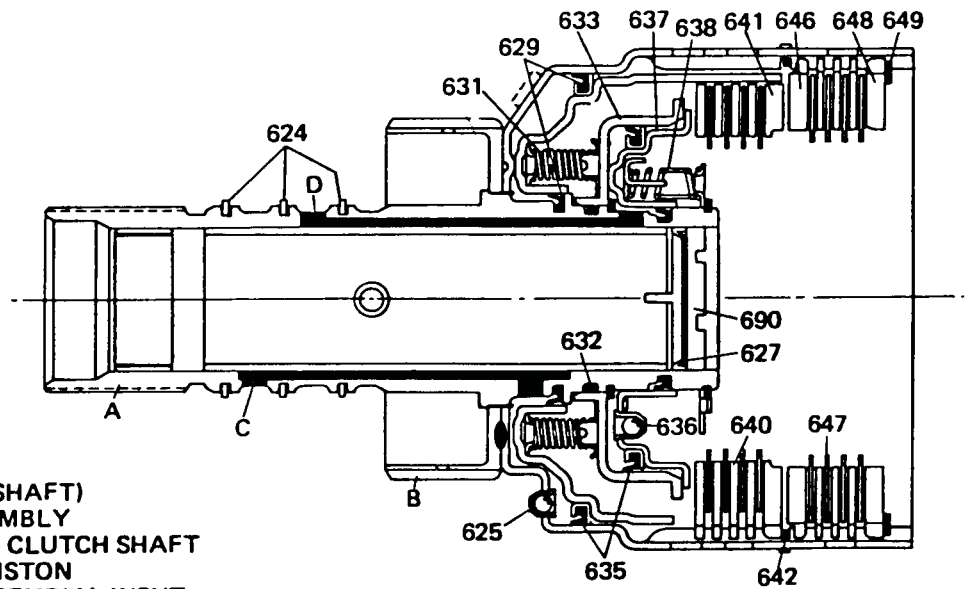

Figure 26



- 523 PISTON, 4TH CLUTCH
- 604 SUPPORT, DRIVEN SPROCKET
- 607 SEAL, "O" RING (SUPPORT/2ND CLUTCH)
- 611 HOUSING, 2ND CLUTCH
- 1 INPUT CLUTCH OIL PASSAGE
- 2 2ND CLUTCH OIL PASSAGE
- 3 3RD CLUTCH OIL PASSAGE
- 4 4TH CLUTCH OIL PASSAGE
- 5 LUBE

Figure 27



- A INPUT SHAFT
- B 2ND CLUTCH HUB
- C INPUT CLUTCH FEED
- D 3RD CLUTCH FEED

- 624 RING, OIL SEAL (INPUT SHAFT)
- 625 RETAINER & BALL ASSEMBLY
- 627 SEAL, INPUT SHAFT/4TH CLUTCH SHAFT
- 629 SEALS, INPUT CLUTCH PISTON
- 631 SPRING & RETAINER ASSEMBLY, INPUT
- 632 SEAL, "O" RING (SHAFT/3RD CL. HOUSING)
- 633 HOUSING, 3RD CLUTCH PISTON
- 635 SEALS, 3RD CLUTCH PISTON
- 636 RETAINER & BALL ASSEMBLY
- 637 PISTON, 3RD CLUTCH
- 638 SPRING RETAINER & GUIDE ASM., 3RD CL.
- 640 PLATE ASSEMBLY, 3RD CLUTCH
- 641 PLATE, 3RD CLUTCH BACKING

- 642 RING, SNAP (3RD CLUTCH BACKING PLATE)
- 643 CAM, 3RD ROLLER CLUTCH
- 646 PLATE, INPUT CLUTCH APPLY
- 647 PLATE ASSEMBLY, INPUT CLUTCH
- 648 PLATE, INPUT CLUTCH BACKING
- 649 RING, SNAP (INPUT CLUTCH BACKING PLATE)
- 690 SLEEVE, LOCK UP

Figure 28

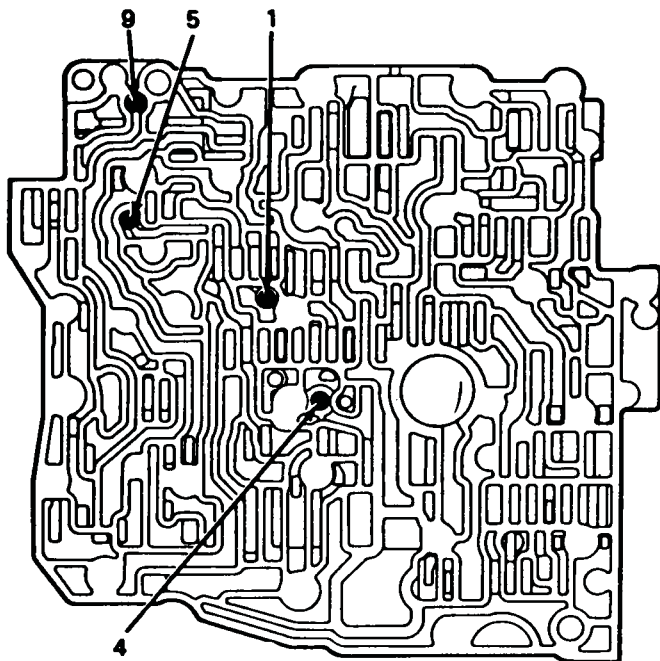

- 1 FOURTH CLUTCH CHECK BALL
- 4 THIRD CLUTCH CHECK BALL
- 5 2-3 ACCUMULATOR FEED CHECK BALL
- 9 REVERSE SERVO FEED CHECK BALL

NO. 7 CHECK BALL LOCATED IN A CAPSULE (137)
IN CASE

SEE INDEX FOR 1985 1/2 AND LATER
VALVE BODY CHECK BALL LOCATION

VALVE BODY CHECK BALL LOCATIONS FOR 1985 HYDRAULICS ONLY

Figure 29

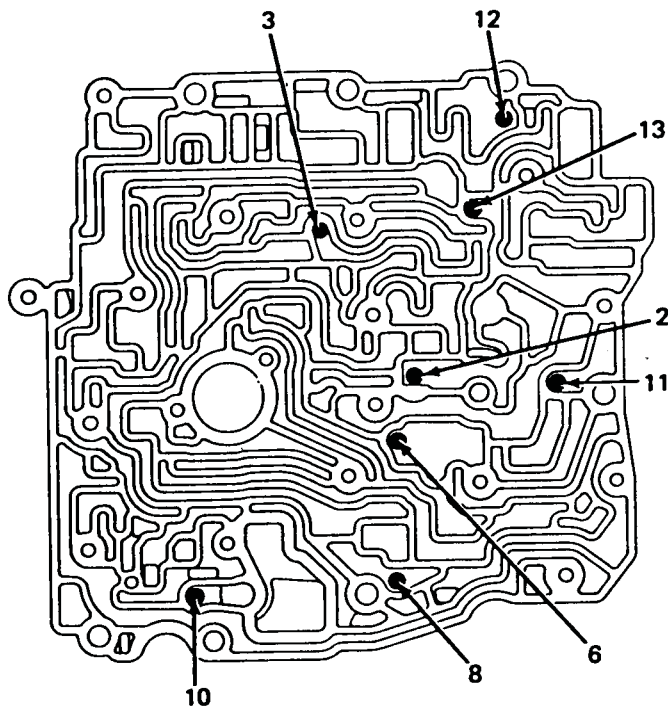

- 2 3-2 CONTROL CHECK BALL
- 3 PART THROTTLE AND DRIVE 3 CHECK BALL
- 6 2-3 ACCUMULATOR EXHAUST CHECK BALL
- 8 SECOND CLUTCH CHECK BALL
- 10 CONV. CLUTCH RELEASE/APPLY CHECK BALL
- 11 THIRD/LO-1ST CHECK BALL
- 12 1-2 SERVO FEED CHECK BALL
- 13 INPUT CLUTCH/REVERSE CHECK BALL

NO. 7 CHECK BALL LOCATED IN A CAPSULE (137)
IN CASE

CHANNEL PLATE CHECK BALL LOCATIONS
DID NOT CHANGE

Figure 30

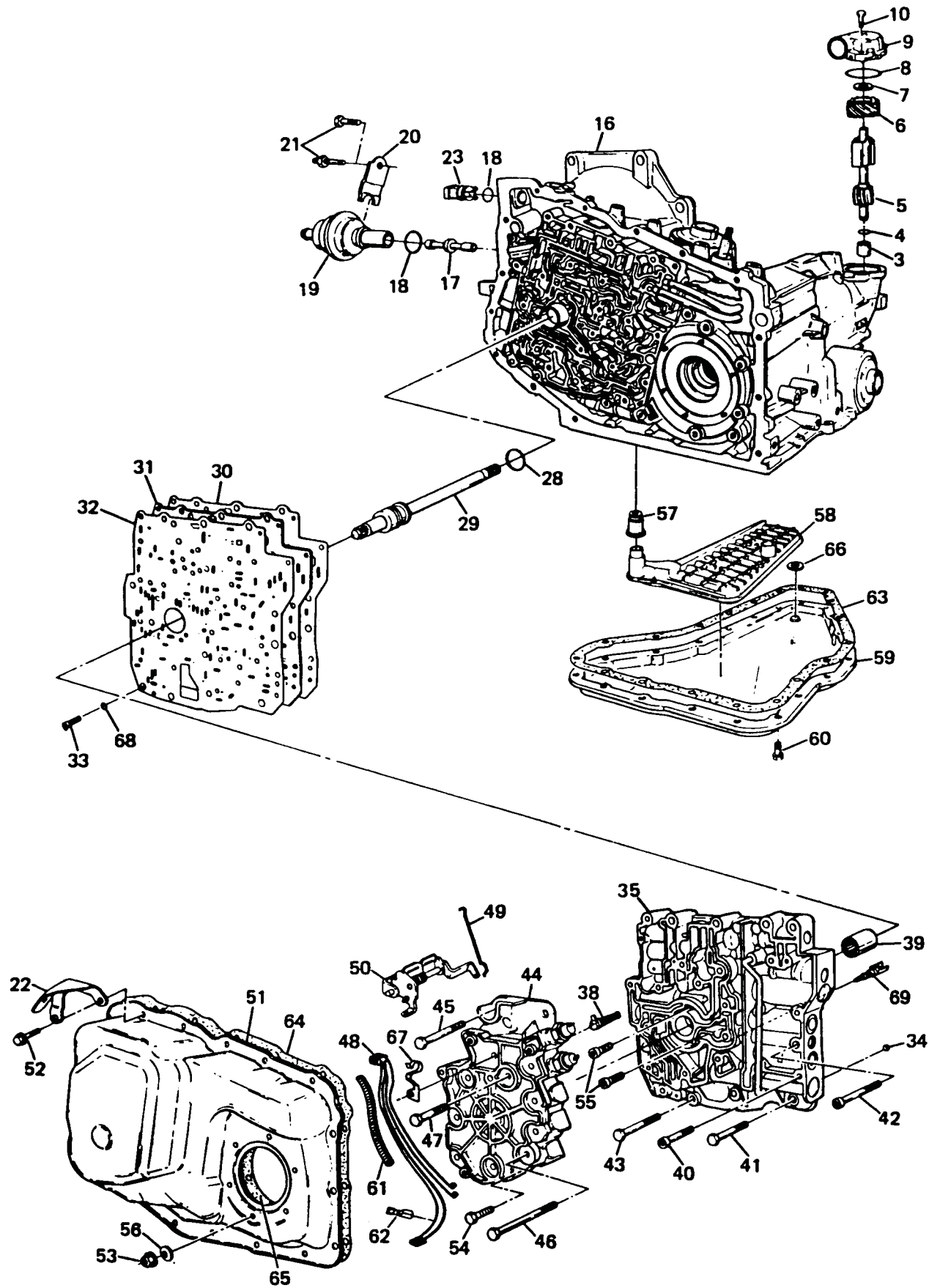

Figure 31

ILL. NO.	DESCRIPTION
3	SLEEVE, GOVERNOR SHAFT
4	RING, OIL SEAL (GOVERNOR SHAFT)
5	GOVERNOR ASSEMBLY
6	GEAR, SPEEDOMETER DRIVE
7	BEARING ASM., THRUST (SPEEDO GEAR)
8	SEAL, "O" RING (GOVERNOR COVER)
9	COVER, GOVERNOR
10	SCREW, GOVERNOR COVER/CASE
16	CASE ASSEMBLY
17	VALVE, MODULATOR
18	SEAL, "O" RING
19	MODULATOR ASSEMBLY
20	RETAINER, MODULATOR
21	BOLT, (MODULATOR)
22	BRACKET, FUEL PIPE (SOME MODELS)
23	ELECTRICAL CONNECTOR
28	RING, OIL SEAL (OIL PUMP)
29	SHAFT, OIL PUMP DRIVE
30	GASKET, SPACER PLATE/CHANNEL PLATE
31	PLATE, VALVE BODY SPACER
32	GASKET, SPACER PLATE/VALVE BODY
33	SCREEN ASM., CONV. CLUTCH SOLENOID
34	BALL, CHECK VALVE
35	VALVE ASSEMBLY, CONTROL
38	SCREEN ASSEMBLY, OIL PUMP PRESSURE
39	BEARING & SLEEVE ASM., OIL PUMP SHAFT
40	BOLT, V. B. TO C. P. (TORQUE HEAD) (6)
41	BOLT, VALVE BODY TO C. P. (HEX) (1)
42	BOLT, V.B. TO DRIVEN SUPPORT (TORQUE) (2)
43	BOLT, VALVE BODY TO CASE (HEX) (3)
44	PUMP ASSEMBLY
45	BOLT, PUMP BODY TO CASE (HEX) (2)
46	BOLT, PUMP COVER TO C. P. (HEX) (10)
47	BOLT, PUMP COVER TO VALVE BODY (HEX) (1)
48	HARNESS, WIRING
49	LINK, THROTTLE LEVER TO CABLE
50	LEVER & BRACKET ASSEMBLY, THROTTLE
51	PAN, CASE SIDE COVER
52	SCREW, SPECIAL M8X1.25X16.0
53	NUT, FLANGED HEX (M6X1.0)
54	BOLT, M6X1.0X35 LG. P.B./C.P. HEX (1)
55	BOLT, M6X1.0X45 LG. V.B./C.P. (2)
56	WASHER, CONICAL
57	SEAL ASSEMBLY, OIL FILTER
58	FILTER ASSEMBLY, OIL
59	PAN, TRANSMISSION OIL
60	SCREW, SPECIAL M8X1.25X16.0)
61	WIRE CONDUIT
62	CLIP, TWO WIRE
63	GASKET, TRANSMISSION OIL PAN
64	GASKET, SIDE COVER TO CASE
65	GASKET, SIDE COVER TO CHANNEL PLATE
66	MAGNET, CHIP COLLECTOR
67	CLIP, WIRE CONDUIT
68	RING, "O" C-C SOLENOID SCREEN
69	SCREEN, 3RD CLUTCH EXHAUST

Figure 31 LEGEND

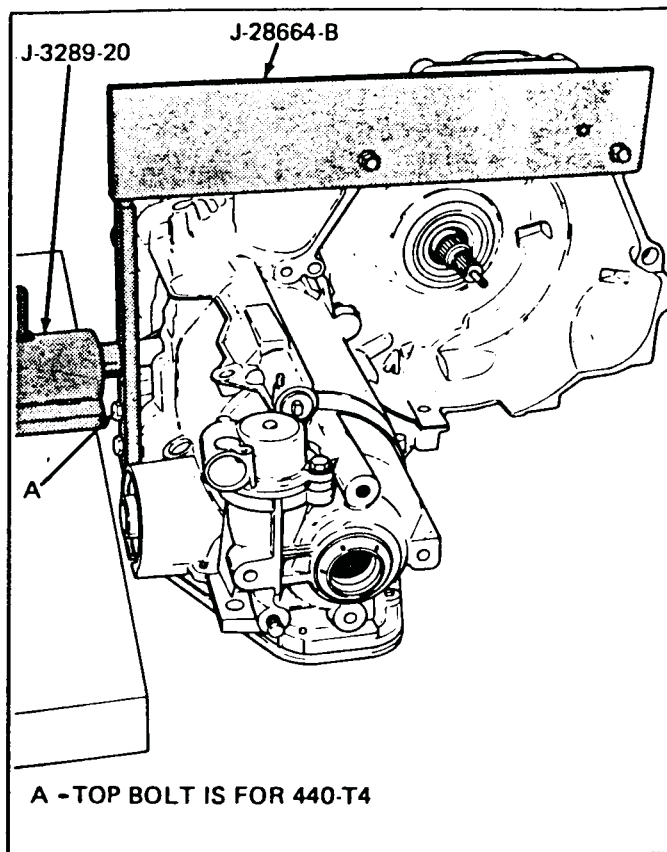
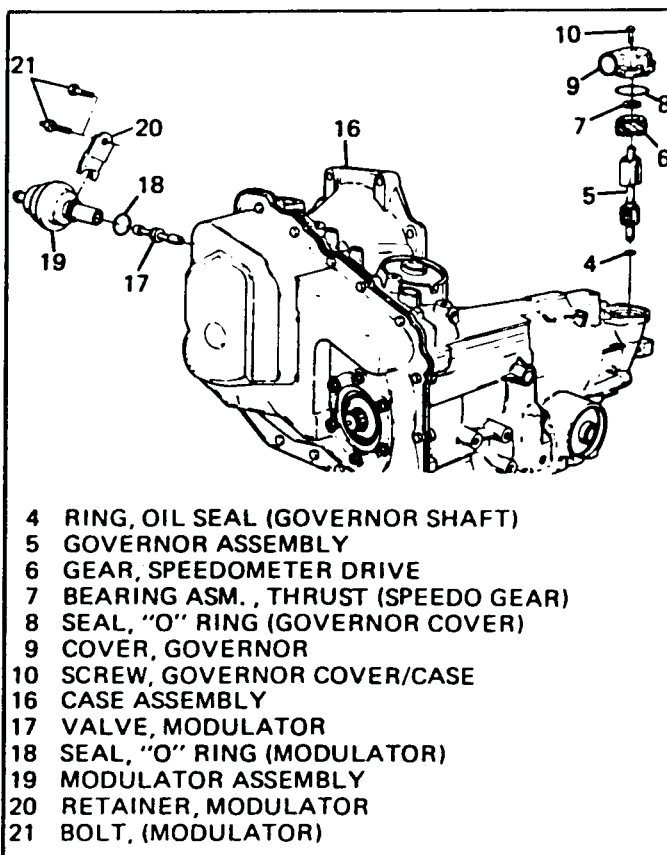

Figure 32



- 4 RING, OIL SEAL (GOVERNOR SHAFT)
- 5 GOVERNOR ASSEMBLY
- 6 GEAR, SPEEDOMETER DRIVE
- 7 BEARING ASM., THRUST (SPEEDO GEAR)
- 8 SEAL, "O" RING (GOVERNOR COVER)
- 9 COVER, GOVERNOR
- 10 SCREW, GOVERNOR COVER/CASE
- 16 CASE ASSEMBLY
- 17 VALVE, MODULATOR
- 18 SEAL, "O" RING (MODULATOR)
- 19 MODULATOR ASSEMBLY
- 20 RETAINER, MODULATOR
- 21 BOLT, (MODULATOR)

Figure 33

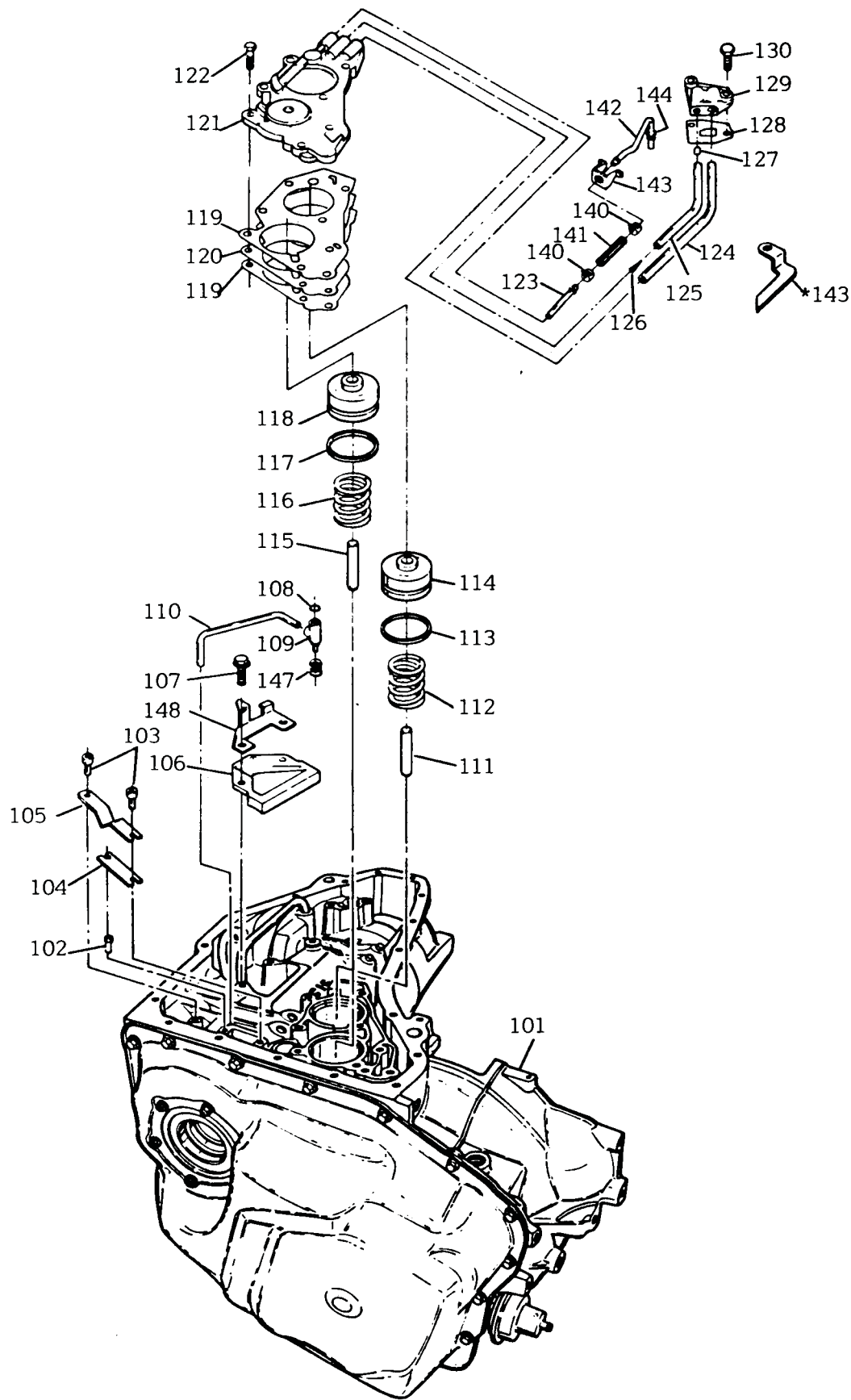

Figure 34

ILL. NO.	DESCRIPTION	ILL. NO.	DESCRIPTION
101	CASE ASSEMBLY, TRANSMISSION	125	PIPE, GOVERNOR FEED
102	PIN, THERMAL ELEMENT	126	SCREEN ASSEMBLY, GOVERNOR
103	PIN & WASHER ASM., THERMO ELEMENT (2)	127	PLUG, ORIFICED CUP (GOVERNOR OIL PIPES RETAINER)
104	PLATE ELEMENT	128	GASKET, GOV. OIL PIPE RETAINER
105	THERMO ELEMENT	129	RETAINER, GOVERNOR OIL PIPE
106	OIL SCOOP, SCAVANGER BOTTOM PAN	130	BOLT, GOVERNOR PIPE RET. (HEX) (2)
107	BOLT, (OIL SCOOP/CASE) (HEX) (2)	132	BOLT, SERVO PIPE RETAINER (TORX.)
108	SEAL, SQ. CUT (LUBE OIL PIPE RET./CASE)	133	BRACKET, SERVO PIPE RETAINER
109	RETAINER, LUBE OIL PIPE	135	PIPE, 1-2 SERVO (REL. OIL)
110	PIPE, LUBE OIL (RETAINER TO DRIVE SPROCKET SUPPORT)	136	PIPE, 1-2 SERVO APPLY
111	PIN, ACCUMULATOR	137	CAPSULE ASSEMBLY, BALL CHECK
112	SPRING, 3-4 ACCUMULATOR	138	SEAL ASSEMBLY, 1-2 SERVO PIPE
113	RING, OIL SEAL ACCUM. PISTON (3-4)	139	STOP, 1-2 BAND ASSEMBLY
114	PISTON, ACCUMULATOR (3-4)	140	CLAMP, HOSE
115	PIN, ACCUMULATOR	141	HOSE, LUBE OIL
116	SPRING, 1-2 ACCUMULATOR	142	PIPE, LUBE OIL
117	RING, OIL SEAL ACCUM. PISTON (1-2)	143	RETAINER, F.D. PIPE LUBE OIL
118	PISTON, ACCUMULATOR (1-2)	*143	RETAINER, F.D. PIPE LUBE OIL (USED ON EARLY MODELS)
119	GASKET, ACCUMULATOR COVER (2)	144	WASHER, F.D. PIPE LUBE OIL RETAINER
120	PLATE, ACCUMULATOR SPACER	147	SPRING, LUBE OIL PIPE RETAINER
121	COVER, ACCUMULATOR	148	BRACKET, 1-2 SERVO PIPES RETAINER
122	BOLT, ACCUMULATOR COVER/CASE (7)		
123	PIPE, LUBE OIL (ACCUMULATOR COVER/ F.D. INTERNAL GEAR)		
124	PIPE, GOVERNOR RETURN		

Figure 34 LEGEND

TRANSAXLE DISASSEMBLY

1. Remove Torque Converter Assembly.
2. Install Transaxle Support Fixture onto transaxle as shown in Figure 32, and make certain that all bolts for fixture are installed as shown and torqued.
3. Install fixture and transaxle assembly into fixture base bolted to bench.
4. Drain fluid from transaxle assembly.

GOVERNOR ASSEMBLY AND MODULATOR

1. Remove governor cover bolts.
2. Remove governor cover, remove and discard governor cover "O" ring.
3. Remove bearing, speedometer gear, and governor assembly.
4. Remove modulator retaining bolt and modulator retainer.
5. Remove modulator assembly, remove and discard modulator "O" ring.
6. Using a magnet, remove modulator valve from transaxle case (See Figure 33).

BOTTOM PAN, FILTER, ACCUMULATOR COVER

1. Rotate transaxle so that bottom pan is facing up.
2. Remove bottom pan bolts, bottom pan, and discard bottom pan gasket.
3. Remove and discard oil filter. If filter is tight, pry up with a screwdriver.
4. Using a 13mm socket, remove accumulator cover bolts and governor adapter bolts. Early model transaxles will have a lube pipe retaining bracket (See Figure 34). Later model units you will have to release the retainer before removing the Accum. cover.
5. Remove accumulator cover, oil pipes, and governor adapter as an assembly.
6. Remove cover spacer plate and gaskets.
7. Remove front lube pipe, plastic retainer, spring, and "O" ring.
8. Remove both accumulator pistons and accumulator pins. Remove and discard accumulator piston seals.
9. Remove both accumulator springs.
10. Remove two pipe bracket and scoop bolts, remove scavenger scoop and oil pipe retaining bracket

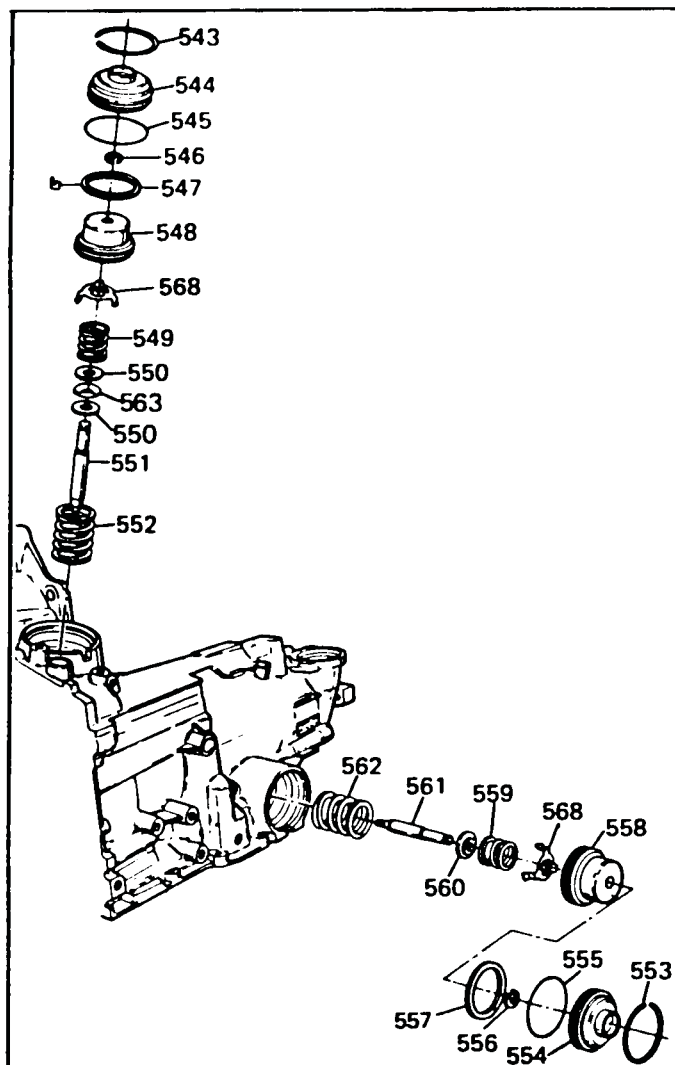

- 543 RING, SERVO COVER RETAINING
 544 COVER, SERVO (REVERSE)
 545 SEAL, "O" RING (COVER TO CASE)
 546 RING, SNAP (BAND APPLY PIN)
 547 SEAL, PISTON
 548 PISTON, REVERSE SERVO
 549 SPRING, REVERSE SERVO CUSHION
 550 RETAINER, SERVO CUSHION SPRING
 551 PIN, REVERSE APPLY
 552 SPRING, SERVO RETURN
 553 RING, SERVO COVER RETAINING
 554 COVER, SERVO (1-2)
 555 SEAL, "O" RING (COVER TO CASE)
 556 RING, SNAP (BAND APPLY PIN)
 557 RING, OIL SEAL PISTON
 558 PISTON, 1-2 SERVO
 559 SPRING, 1-2 SERVO CUSHION
 560 RETAINER, SERVO CUSHION SPRING
 561 PIN, 1-2 BAND APPLY
 562 SPRING, SERVO RETURN
 563 SPRING, REVERSE SERVO CURVED
 568 RETAINER, SERVO SPRING

Figure 35

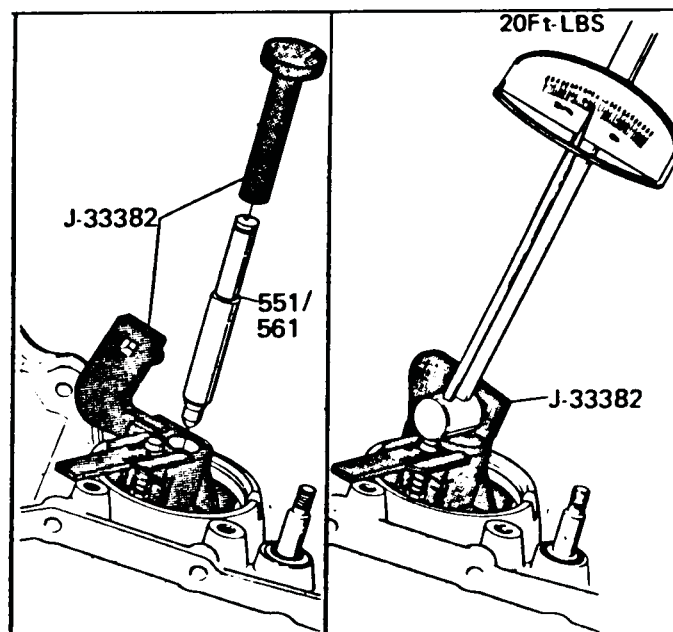

- 551 PIN, REVERSE APPLY OR
 561 PIN, 1-2 APPLY

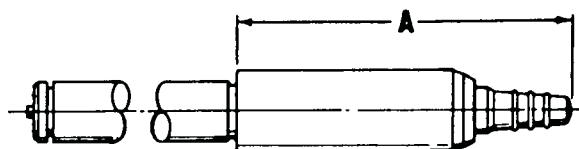

REVERSE BAND APPLY PIN

IDENTIFICATION	DIMENSION A
2 WIDE BANDS	2.789" - 2.795"
3 GROOVES & WIDE BAND	2.831" - 2.837"
2 GROOVES & WIDE BAND	2.872" - 2.878"
1 GROOVE & WIDE BAND	2.913" - 2.919"
NO GROOVE	2.953" - 2.959"
1 GROOVE	2.995" - 3.001"
2 GROOVE	3.036" - 3.042"
3 GROOVE	3.077" - 3.083"
4 GROOVE	3.118" - 3.124"

1-2 BAND APPLY PIN

IDENTIFICATION	DIMENSION A
1 RING & WIDE BAND	2.214" - 2.220"
1 RING	2.253" - 2.259"
2 RINGS	2.294" - 2.300"
3 RINGS	2.335" - 2.341"
WIDE BAND	2.375" - 2.381"
2 RINGS & WIDE BAND	2.415" - 2.421"

Figure 36



Technical Service Information

REVERSE SERVO AND 1-2 SERVO

1. Apply pressure to the servo cover and remove the snap ring.
2. Using a screwdriver, pull the servo cover "O" ring seal up through one of the slots in the case. Now, cut the seal and grasp one end. Pull the end of the seal and turn the servo cover in the same direction. After the seal is removed, the servo cover will come out very easily.
3. Remove the servo assembly. The servo assemblies will not interchange. The reverse servo pin is longer than the 1-2 servo pin.
4. Remove the servo return springs.
5. Remove the "E" clip from the servo pin, and remove the servo pin from piston.
6. Using the proper apply pin with J-33382 tool (Figure 36), measure for correct servo pin length.
7. The same procedure and tool are used for both the reverse servo and the 1-2 servo.

CHECKING SERVO PIN LENGTH

1. Install J-33382 tool as shown in Figure 36. Use the reverse servo pin for checking the reverse servo, and the 1-2 pin for checking the 1-2 servo. They are different lengths.
2. Apply 20 ft. lbs. torque to the tool as shown in Figure 36.
3. Check the pin length with the tool.
 - *If the "GO" side will not slide under the head, the pin is too short.
 - *If the "NO-GO" side will slide under the head, the pin is too long.
 - *If the "GO" side will slide under the head, and the "NO-GO" side will not, pin length is correct.
4. Correct the pin length as necessary using the chart in Figure 37.

REVERSE BAND APPLY PIN		
IDENTIFICATION	DIMENSION "A"	PART NUMBER
2 WIDE BANDS	2.789" - 2.795"	8658239
3 GROOVES & WIDE BAND	2.831" - 2.837"	8658240
2 GROOVES & WIDE BAND	2.872" - 2.878"	8658241
1 GROOVE & WIDE BAND	2.913" - 2.919"	8656543
NO GROOVE	2.953" - 2.959"	8656545
1 GROOVE	2.995" - 3.001"	8656546
2 GROOVE	3.036" - 3.042"	NOT AVAILABLE
3 GROOVE	3.077" - 3.083"	NOT AVAILABLE
4 GROOVE	3.118" - 3.124"	NOT AVAILABLE
1-2 BAND APPLY PIN		
IDENTIFICATION	DIMENSION "A"	PART NUMBER
1 RING & WIDE BAND	2.214" - 2.220"	8656537
1 RING	2.253" - 2.259"	8656539
2 RINGS	2.294" - 2.300"	8656540
3 RINGS	2.335" - 2.341"	8656541
WIDE BAND	2.375" - 2.381"	8656542
2 RINGS & WIDE BAND	2.415" - 2.421"	8656538

Figure 37

AUTOMATIC TRANSMISSION SERVICE GROUP

- | | |
|--|--|
| 22 BRACKET, FUEL PIPE (SOME MODELS)
30 GASKET, SPACER PLATE/CHANNEL PLATE
31 PLATE, VALVE BODY SPACER
32 GASKET, SPACER PLATE/VALVE BODY
33 SCREEN ASM., CONV. CLUTCH SOLENOID
35 VALVE ASSEMBLY, CONTROL
40 BOLT, V.B. TO C.P. (TORQUE HD.) (6)
41 BOLT, V.B. TO C.P. (HEX) (1)
42 BOLT, V.B. TO DRIVEN SUPPORT (TORQ.) (2)
43 BOLT, VALVE BODY TO CASE (HEX) (3)
44 PUMP ASSEMBLY
45 BOLT, PUMP BODY TO CASE (HEX) (2)
46 BOLT, PUMP COVER TO C.P. (HEX) (10)
47 BOLT, PUMP COVER TO V.B. (HEX) (1)
48 HARNESS, WIRING
49 LINK, THROTTLE LEVER TO CABLE
50 LEVER & BRACKET ASM., THROTTLE
51 PAN, CASE SIDE COVER
52 SCREW, SPECIAL M8X1.25X16.0
53 NUT, FLANGED HEX (M6X1.0)
54 BOLT, M6X1.0X35 LG. P.B./
C.P. (HEX) (1)
55 BOLT, M6X1.0X45 LG. V.B./
C.P. (2) | 56 WASHER, CONICAL
61 WIRE CONDUIT
62 CLIP, TWO WIRE
64 GASKET, SIDE COVER TO CASE
65 GASKET, SIDE COVER TO CHANNEL PLATE
67 CLIP, WIRE CONDUIT
68 "O" RING, C-C SOLENOID SCREEN
(NOT USED ON EARLY MODELS)
72 PLATE, CLAMPING
132 BOLT, SERVO PIPE RETAINER (TORX.)
133 BRACKET, SERVO PIPE RETAINER
689 WIER, OIL |
|--|--|

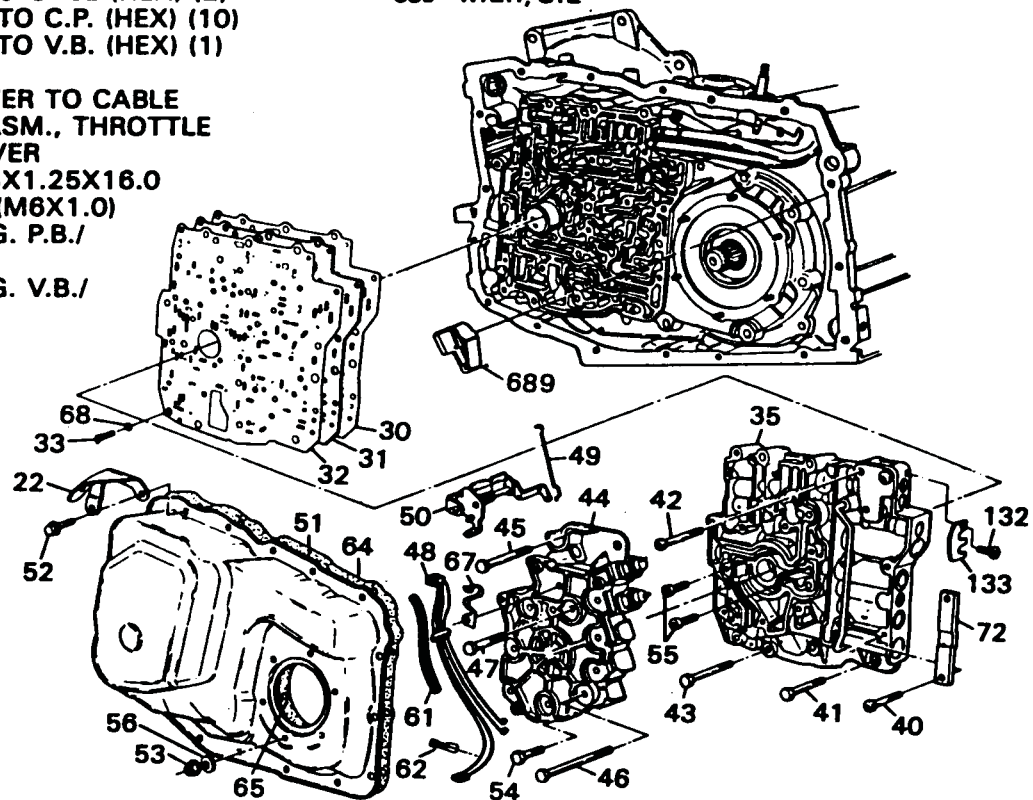
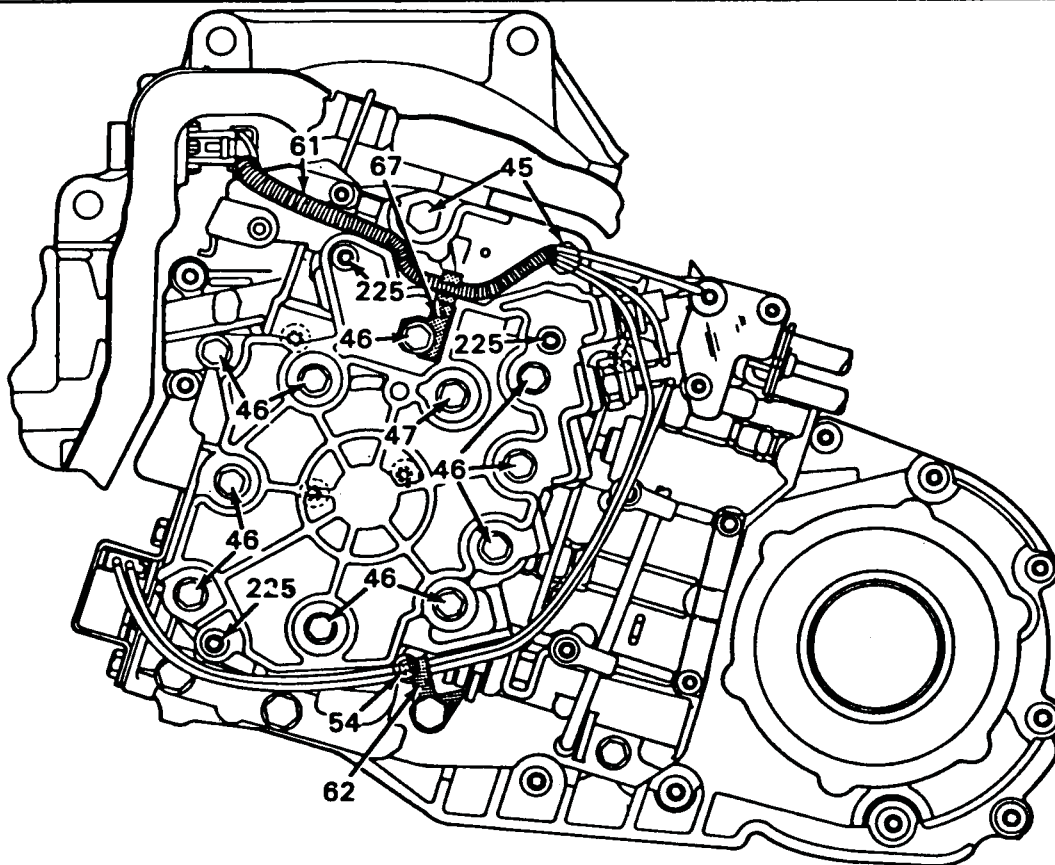

Figure 38

OIL PUMP ASSEMBLY

1. Remove side cover bolts, and the nuts and cone shaped washers around the axle shaft.
2. Remove the side cover, remove and discard side cover gasket and "Doughnut" gasket.
3. Depress locking tab on solenoid and disconnect wiring harness from solenoid.
4. Remove wiring harness from remaining wire clips and switches.
5. Depress locking tab on case connector and remove wiring harness assembly.
6. Remove all eleven 10mm bolts marked 46 & 47 in Figure 39.
7. Remove two 13mm bolts at top of oil pump marked 45 in Figure 39.
8. Remove 30 torx head bolt marked 54 in Figure 39.
9. Do not remove the three 40 torx head bolts marked 225 in Figure 39. This will retain the pump cover on the pump assembly.
10. Remove the oil pump assembly by lifting straight up, and set the oil pump Asy. aside for now.
11. Use care so as not to damage the pump screen protruding from the back side of oil pump assembly.



- 45 M8 X 1.25 X 95 LG. (2) HEX HD. BOLT — 20.0 - 27.0 N·m (15 - 20 FT.-LBS.)
 46 M6 X 1.0 X 85 LG. (10) HEX HEAD BOLT — 8.0 - 14.0 N·m (6 - 10 FT.-LBS.)
 47 M6 X 1.0 X 45 LG. (1) HEX HEAD BOLT — 8.0 - 14.0 N·m (6 - 10 FT.-LBS.)
 54 M6 X 1.0 X 35 LG. (1) SOCKET HEAD BOLT — 8.0 - 14.0 N·m (6 - 10 FT.-LBS.)
 61 CONDUIT, WIRE
 62 CLIP, TWO WIRE
 67 CLIP, WIRE CONDUIT
 225 M8 X 1.25 X 20 LG. (3) SIX LOBED SOCKET HEAD SCREW — 20.0 - 27.0 N·m (15 - 20 FT.-LBS.)

Figure 39

AUTOMATIC TRANSMISSION SERVICE GROUP

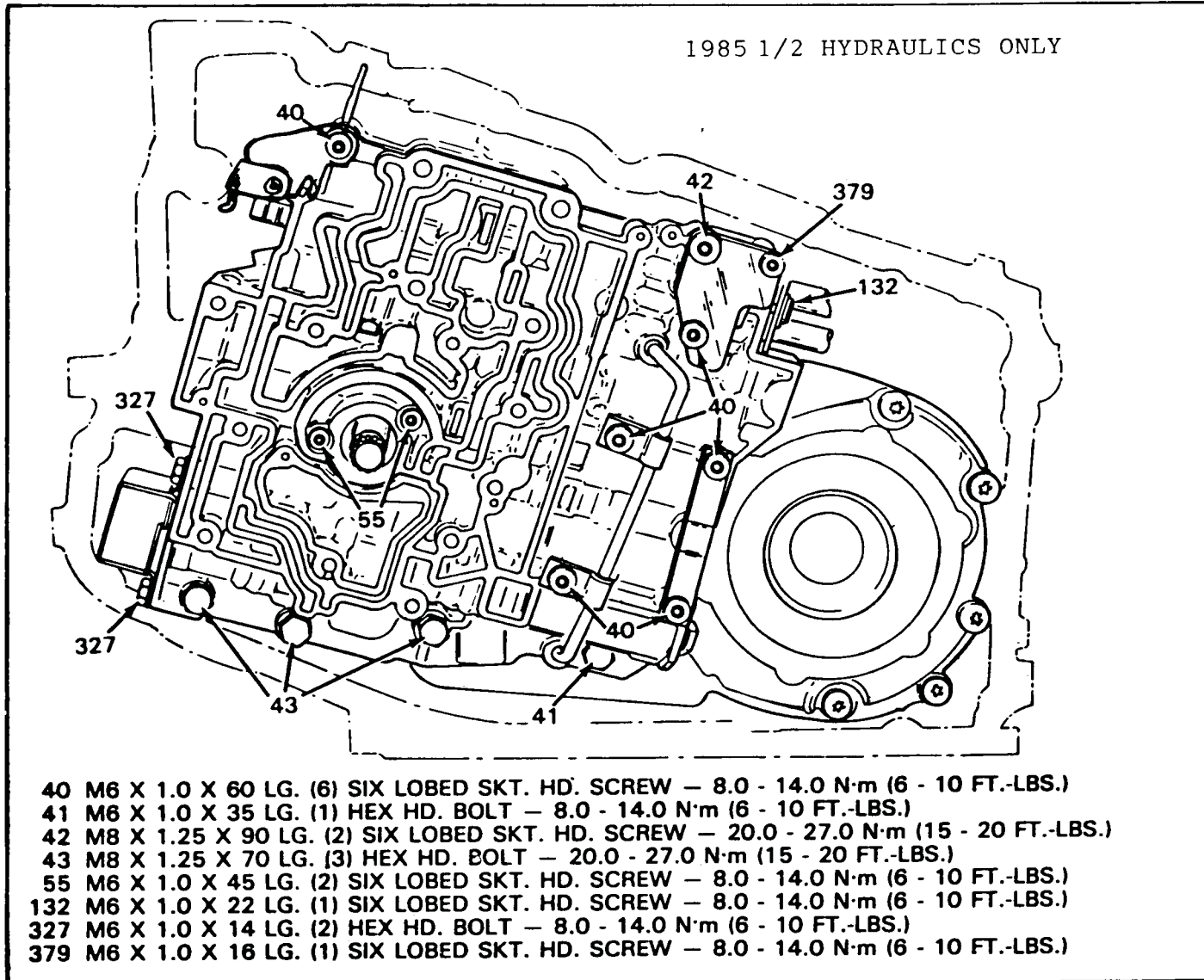

Figure 40

VALVE BODY, SPACER PLATE, GASKETS, AND CHECK BALLS

1. Remove servo pipe retaining bracket bolt, marked 132 in Figure 40, and remove pipe retaining bracket.
2. Pull both servo pipes out of valve body and install large rubber band around servo pipes. Pull rubber band around the case and hook on the manual shaft to keep servo pipes out of the way when removing valve body.
3. Remove six 30 torx head bolts, marked 40, in Figure 40. Also remove tension plate, pipe brackets, and throttle valve linkage assembly.
4. Remove one 40 torx head bolt marked 42, in Figure 40.
5. Remove three 13mm bolts marked 43, in Figure 40.
6. Remove two 30 torx head bolts marked 55, in Figure 40.
7. Remove one 10mm bolt (Sometimes 30 Torx) marked 41 in Figure 40.
8. Do not remove servo release plate at this time.
9. Lift straight up and remove valve body.
10. Four checkballs should be remaining on the spacer plate. Remove them at this time.
NOTE: Checkball locations will vary depending on which hydraulics you are working on.
For 1985 hydraulics, see Figure 43.
For 1985 1/2 hydraulics, see Figure 44.
11. Remove TCC screen from spacer plate. These also will differ depending on early or late model (See Page 40).
12. Remove spacer plate and gaskets, and discard gaskets.
13. Remove oil pump drive shaft, remove scarf cut sealing ring and discard.
14. Remove eight checkballs from channel plate. Checkball locations in the channel plate did not change.
15. See Figure 41 for channel plate check ball locations.

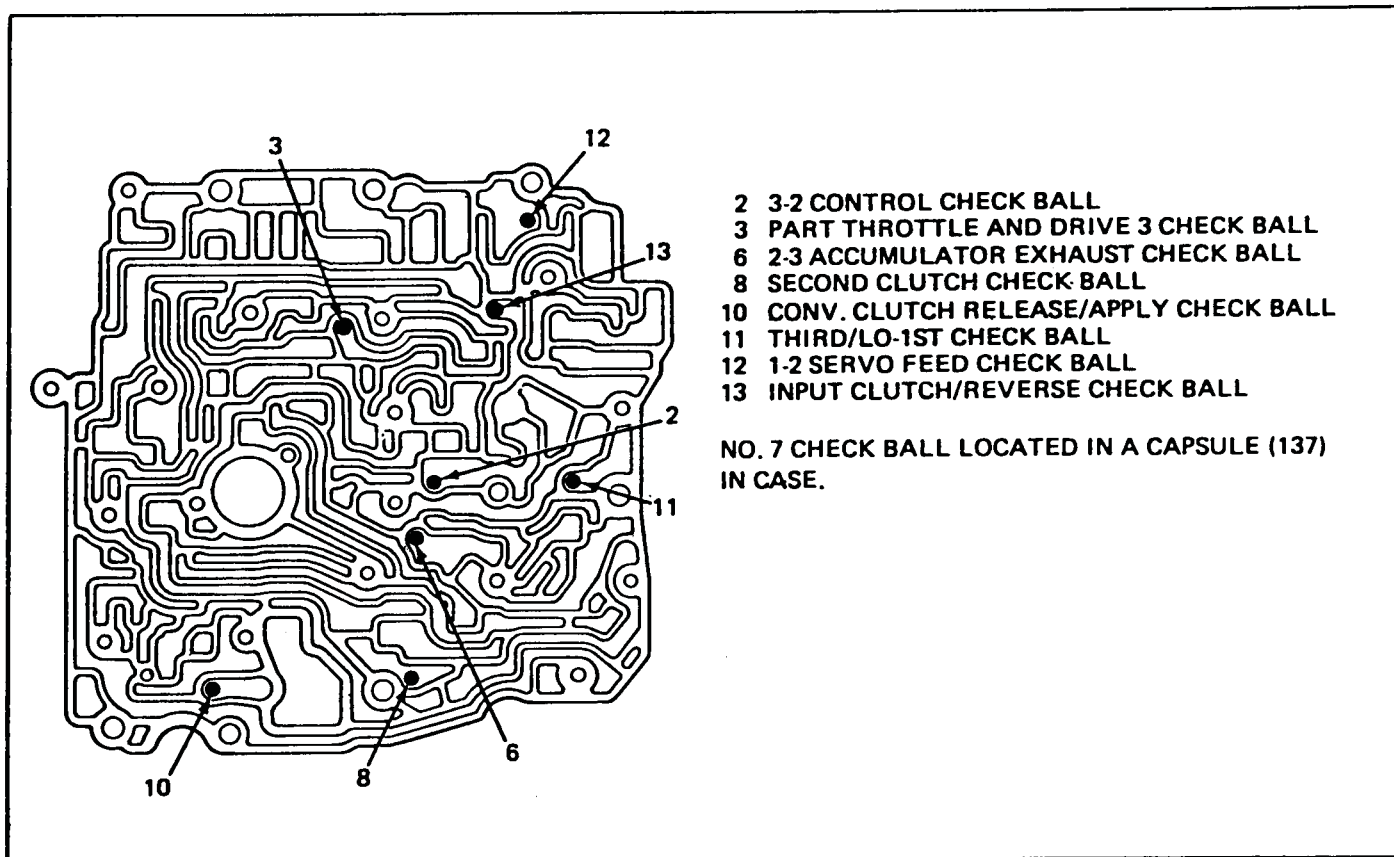
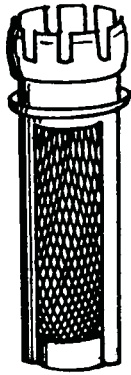
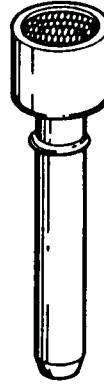

Figure 41

AUTOMATIC TRANSMISSION SERVICE GROUP



"EARLY" MODEL TCC SCREEN
(ORIFICE IN SPACER PLATE)
8646474



"LATE" MODEL TCC SCREEN
AND ORIFICE ASSEMBLY
8658060

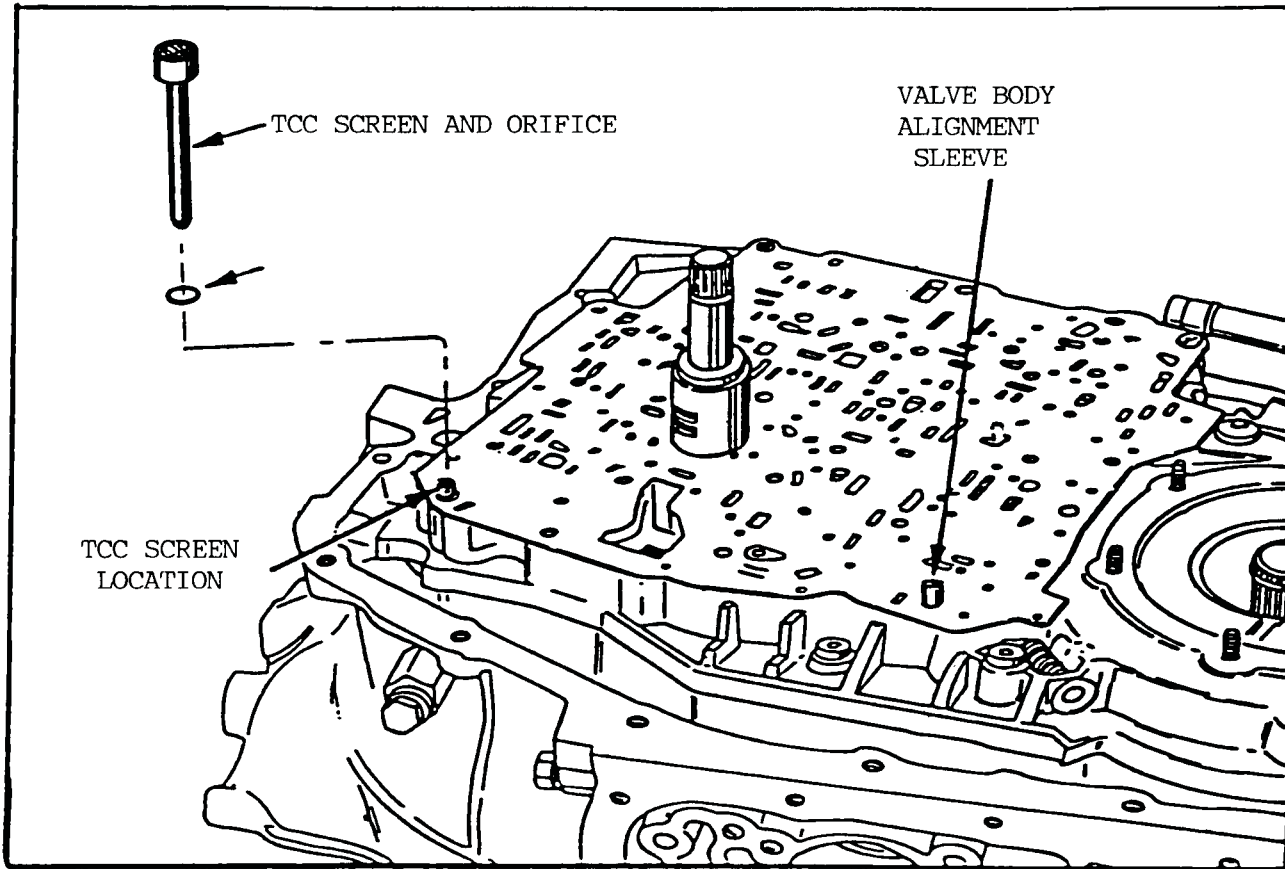

Figure 42

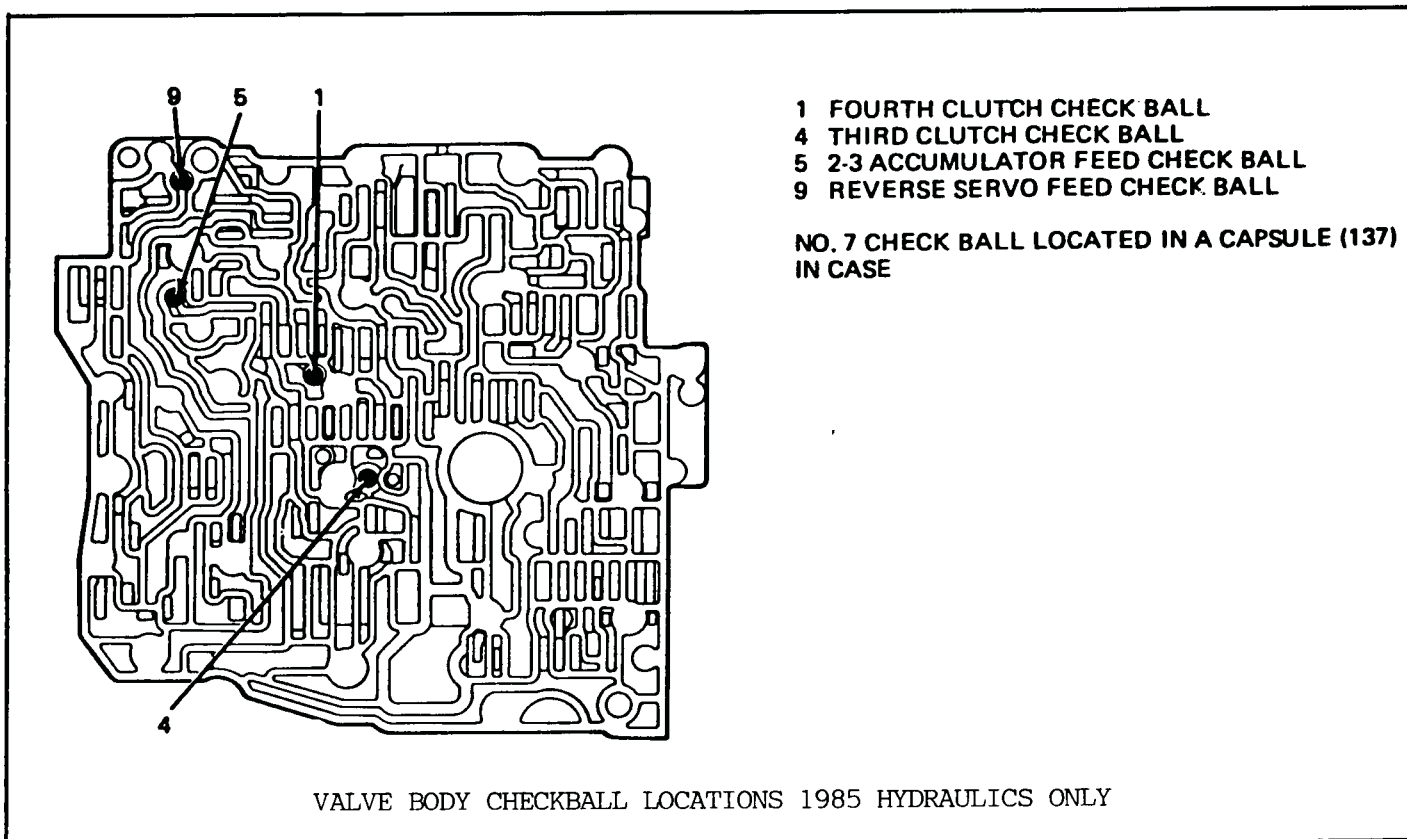

Figure 43

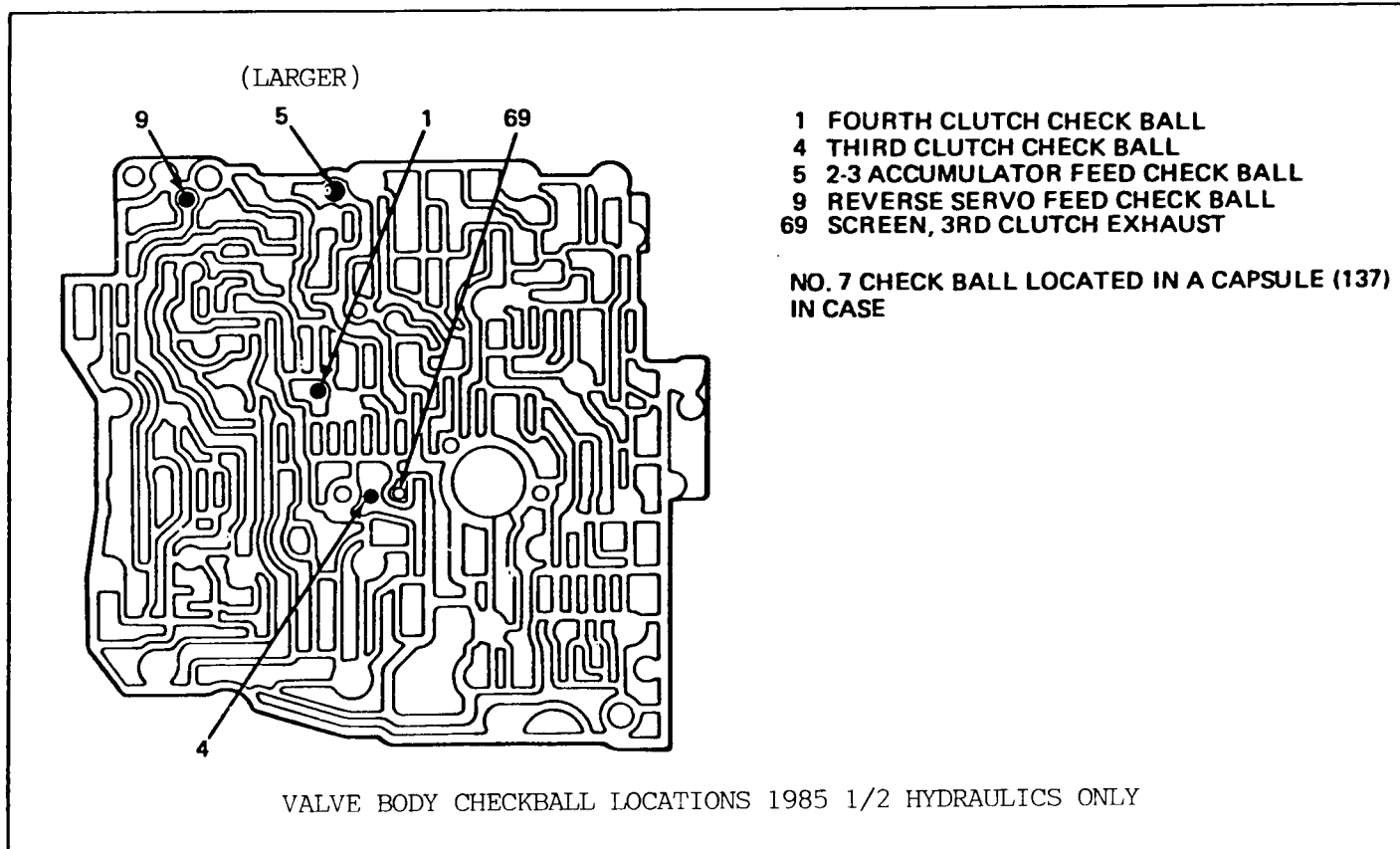

Figure 44

AUTOMATIC TRANSMISSION SERVICE GROUP

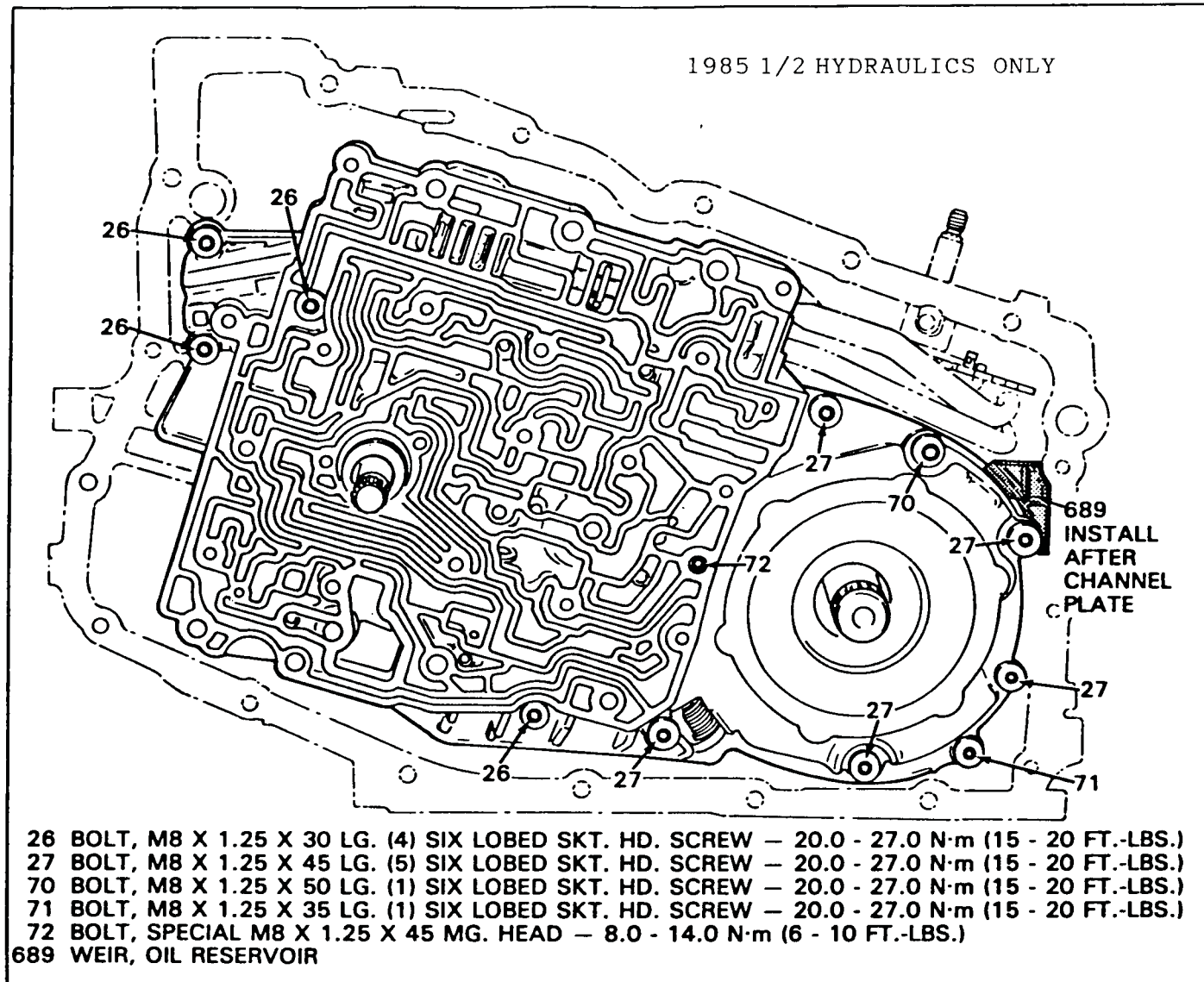

Figure 45

CHANNEL PLATE AND ASSOCIATED PARTS

1. Remove oil weir from case, marked 689 in Figure 45.
2. Pull spring towards detent lever and disconnect manual valve link from manual valve. Early model units have a clip in this location. Place detent lever in the park position for clip removal.
3. Remove five 40 torx head bolts marked 26 & 71 in Figure 45. Notice that 71 is longer than all the rest.
4. Remove six 40 torx head bolts marked 27 & 70 in Figure 45. Notice that 70 is longer than all the rest.
5. Remove valve body alignment sleeve from channel plate (May be in Valve Body).
6. Remove one 30 torx head bolt marked 72 in Figure 45. This bolt will be found on 85 1/2 hydraulics only.
7. Remove channel plate from case.
8. Remove and discard three channel plate gaskets.
9. Remove TCC and Input accumulator pins and pistons. Pins may be in case.
10. Remove and discard accumulator "O" ring seals. (See Figure 47).
11. Remove 3-2 line control valve from channel plate and inspect for broken 3-2 line control valve clip. (See Figure 48). Notice that there are different line-ups depending on engine size.

24 CHANNEL PLATE ASSEMBLY

25 BALL, CHECK VALVE (7)

26 BOLT, CHANNEL PLATE TO CASE (5)

27 BOLT, C.P. TO DRIVEN SUPPORT (6)

28 RING, OIL SEAL (OIL PUMP)

29 SHAFT, OIL PUMP DRIVE

30 GASKET, SPACER PLATE/CHANNEL PLATE

31 PLATE, VALVE BODY SPACER

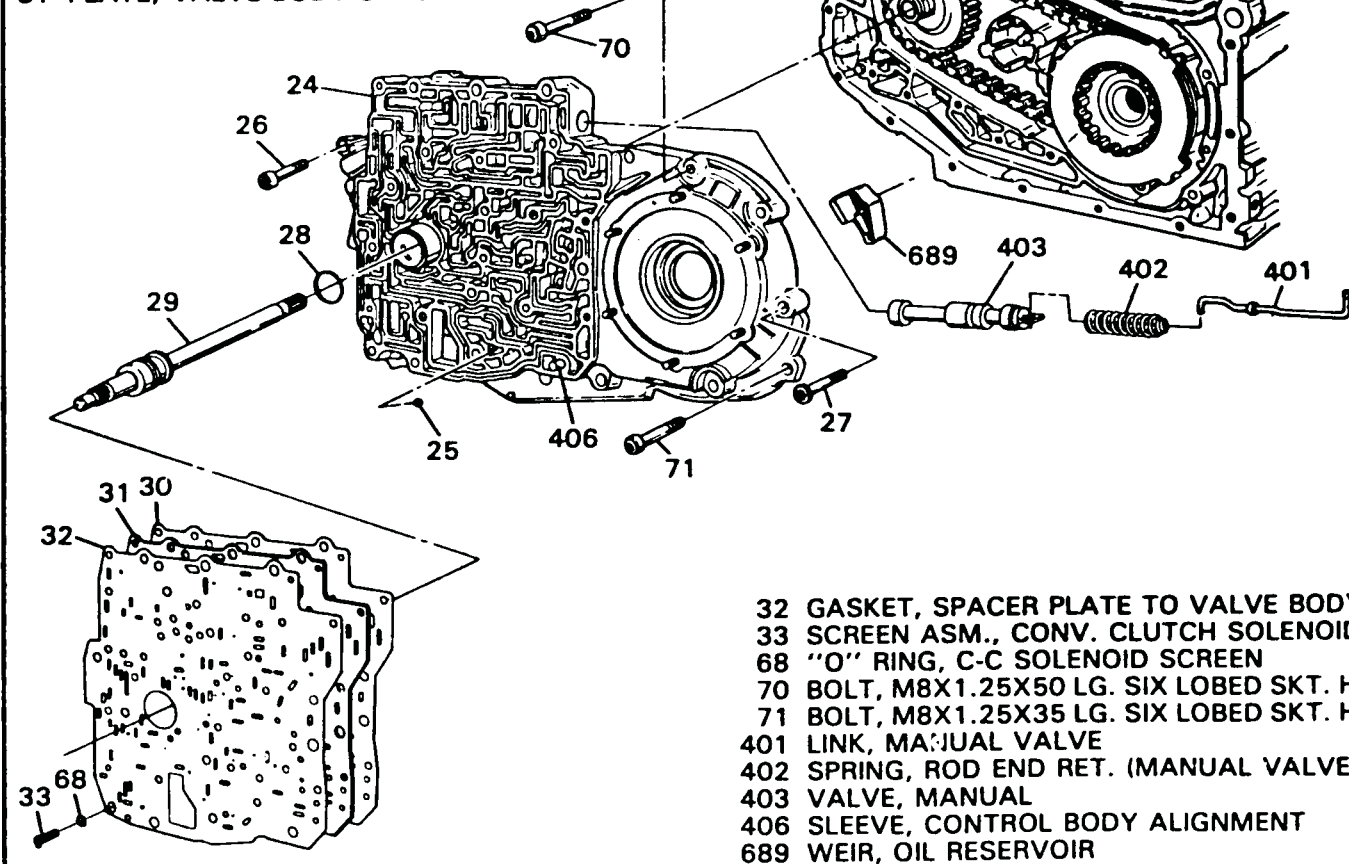

- 32 GASKET, SPACER PLATE TO VALVE BODY
 33 SCREEN ASM., CONV. CLUTCH SOLENOID
 68 "O" RING, C-C SOLENOID SCREEN
 70 BOLT, M8X1.25X50 LG. SIX LOBED SKT. HD.
 71 BOLT, M8X1.25X35 LG. SIX LOBED SKT. HD.
 401 LINK, MANUAL VALVE
 402 SPRING, ROD END RET. (MANUAL VALVE)
 403 VALVE, MANUAL
 406 SLEEVE, CONTROL BODY ALIGNMENT
 689 WEIR, OIL RESERVOIR

Figure 46

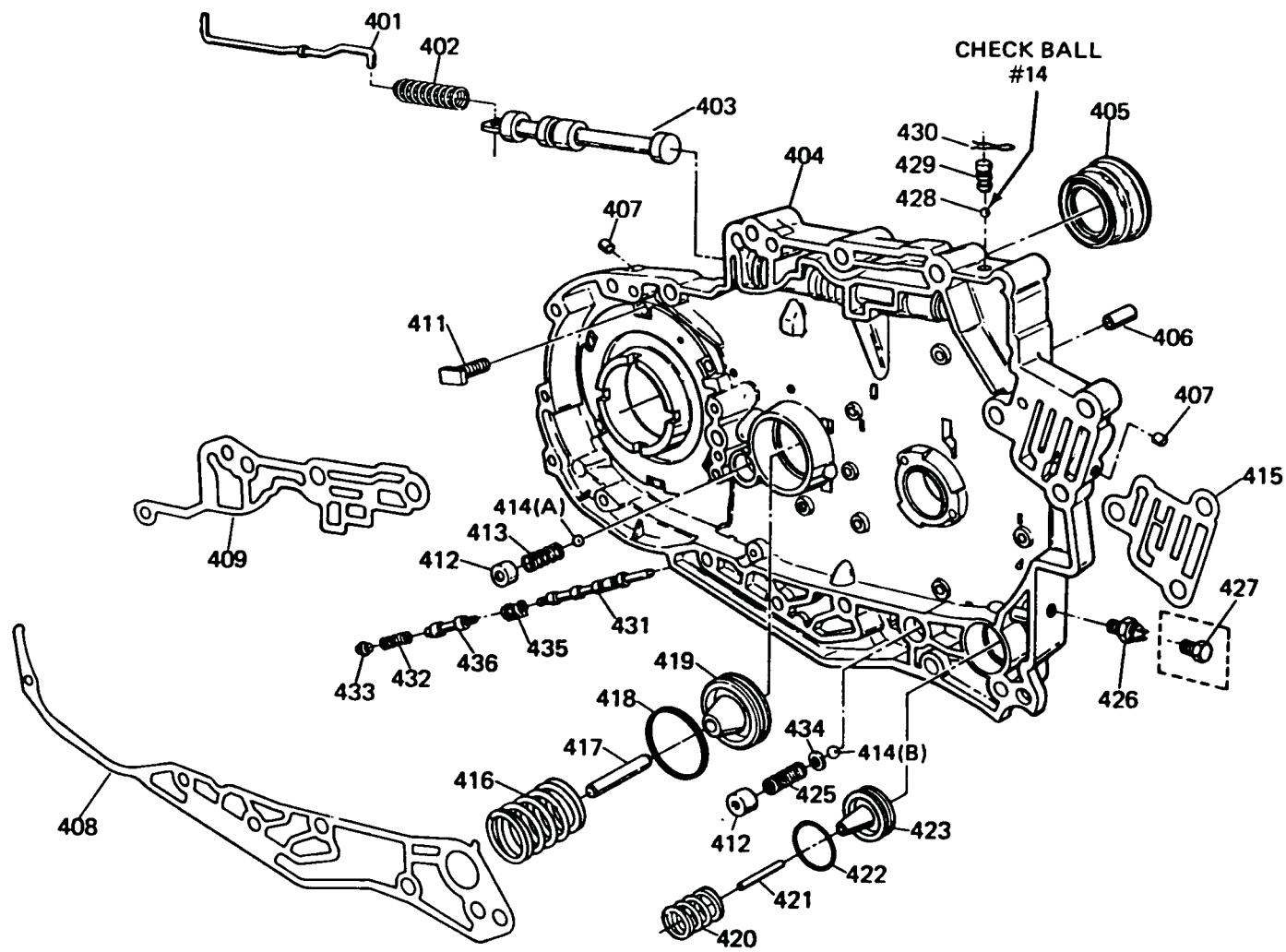

1985 1/2 HYDRAULICS ONLY

- | | |
|--|---|
| 401 LINK, MANUAL VALVE | 419 PISTON, INPUT CLUTCH ACCUMULATOR |
| 402 SPRING, ROD END RETAINING (MANUAL VALVE) | 420 SPRING, CONV. CLUTCH ACCUMULATOR |
| 403 VALVE, MANUAL | 421 PIN, CONVERTER CLUTCH ACCUMULATOR |
| 404 CHANNEL PLATE | 422 SEAL, CONVERTER CLUTCH ACCUMULATOR |
| 405 SEAL ASSEMBLY, AXLE OIL | 423 PISTON, CONV. CLUTCH ACCUMULATOR |
| 406 SLEEVE, CONTROL BODY ALIGNMENT | 425 SPRING, CONVERTER CLUTCH BLOW-OFF |
| 407 PLUG, CUP | 414B BALL, CONVERTER CLUTCH BLOW-OFF |
| 408 GASKET, CHANNEL PLATE (LOWER) | 426 SWITCH ASSEMBLY, TEMPERATURE (VISCOUS ONLY) |
| 409 GASKET, CHANNEL PLATE (UPPER) | 427 PLUG, PIPE (ALL BUT VISCOUS) |
| 411 STUD, M6X1X18.1 CHANNEL PLATE SIDE COVER (6) | 428 BALL, CHECK (#14 DETENT MODULATOR) |
| 412 PLUG, CUP (2) | 429 PLUG, BALL CHECK SEAT |
| 413 SPRING, LOW BLOW-OFF | 430 RETAINER, SPRING CLIP |
| 414A BALL, LOW BLOW-OFF | 431 VALVE, 3-2 LINE CONTROL PRIMARY |
| 415 GASKET, MODULATOR PORT | 432 SPRING, 3-2 LINE CONTROL |
| 416 SPRING, INPUT CLUTCH ACCUMULATOR | 433 PLUG, 3-2 LINE CONTROL |
| 417 PIN, INPUT CLUTCH ACCUMULATOR | 434 SEAT, SPRING |
| 418 SEAL, RING (INPUT CLUTCH ACCUMULATOR) | 435 RETAINER, 3-2 LINE CONTROL |
| | 436 VALVE, 3-2 LINE CONTROL SECONDARY |

Figure 47

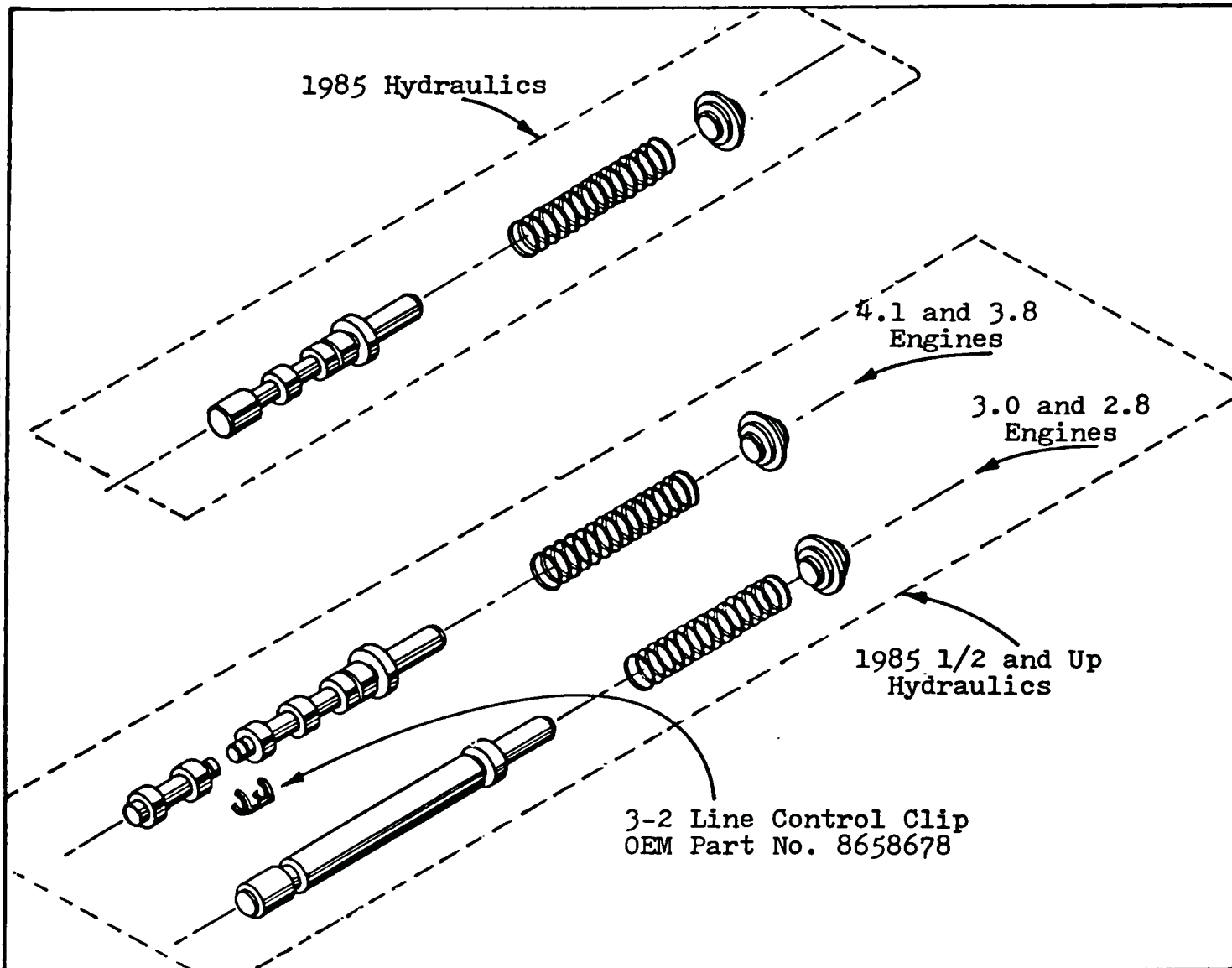

Figure 48

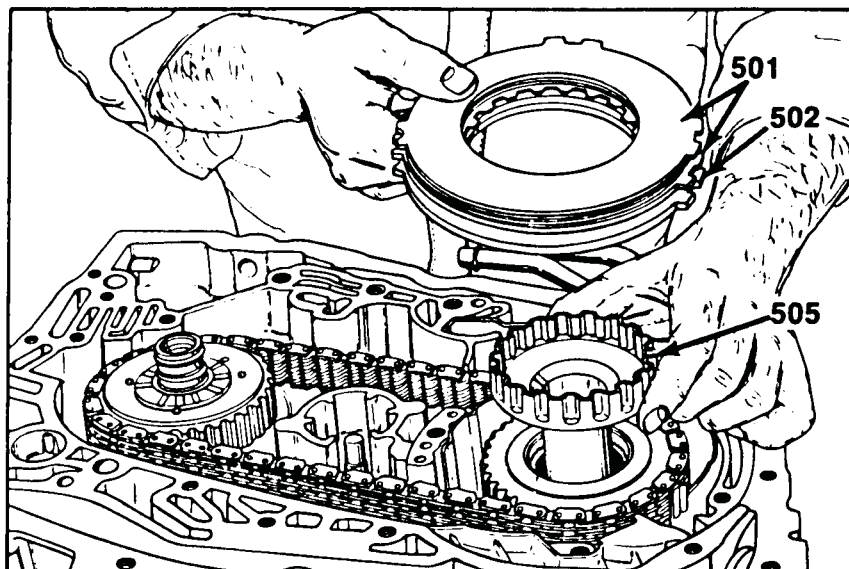

Figure 49

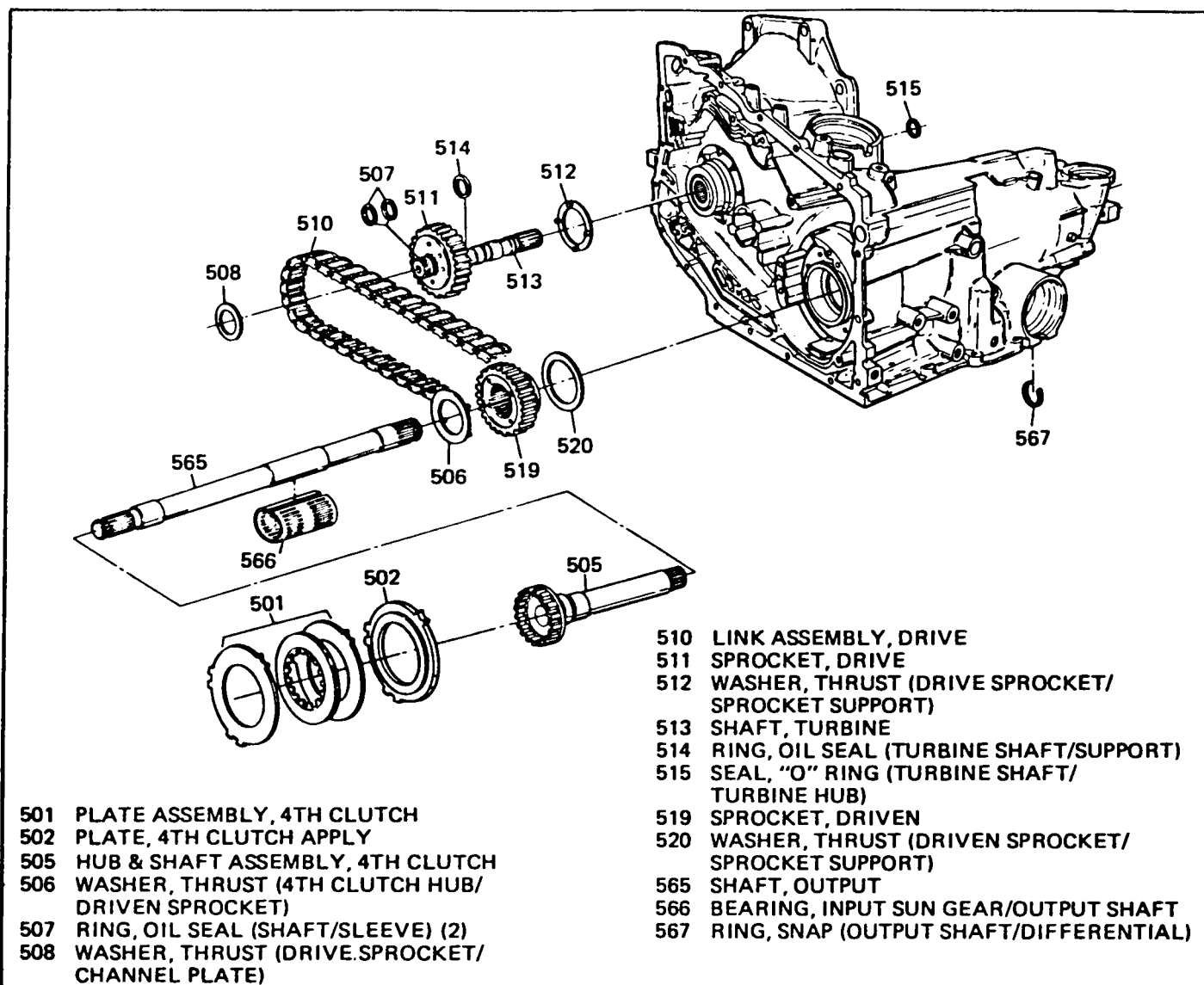

Figure 50

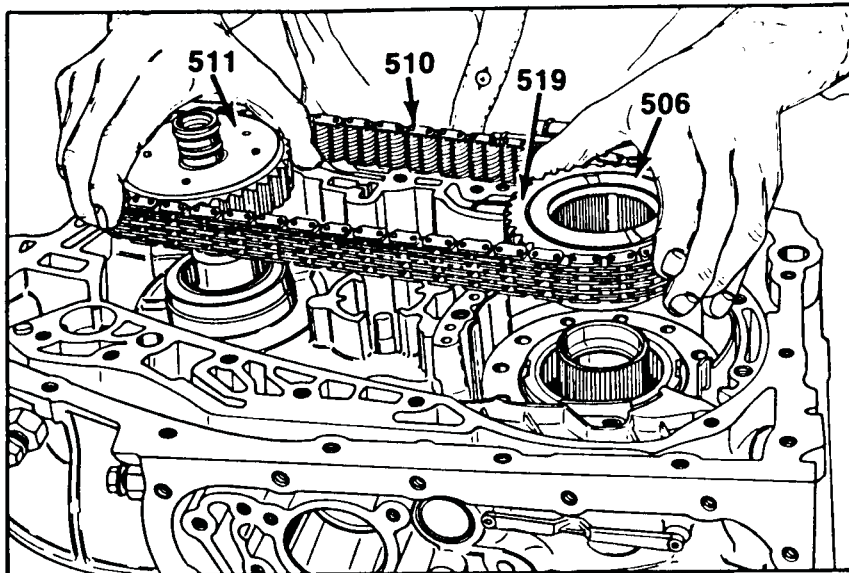

Figure 51

**4TH CLUTCH PLATES, OUTPUT SHAFT, SPROCKETS
AND DRIVE CHAIN**

1. Remove TCC and Input accumulator springs from the case.
2. Note the position of the tangs of the 4th clutch plates and remove them from the transaxle (See Figure 49).
3. Remove the 4th clutch hub and shaft (See Figure 49).
4. Rotate the output shaft until "C" clip opening is visible thru final drive, and remove "C" clip with removal tool J-28583. (See Figure 53).
5. Remove output shaft and bearing assembly.
6. Remove and discard "O" ring from front of turbine shaft.
7. Remove the chain scoop from case. There are two colors of chain scoops, black is for 37-33 sprocket ratio, and white is for 35-35 sprocket ratio. They cannot be interchanged.
8. Remove thrust washer from the drive sprocket if present. It may be on the channel plate.
9. Grasp both sprockets and the drive chain and lift straight up to remove. If they are tight, pry gently under each sprocket with a screwdriver and try again.
10. Note the position of the black link on the chain, it should be facing up.
11. Remove thrust washers from the drive sprocket and the driven sprocket support

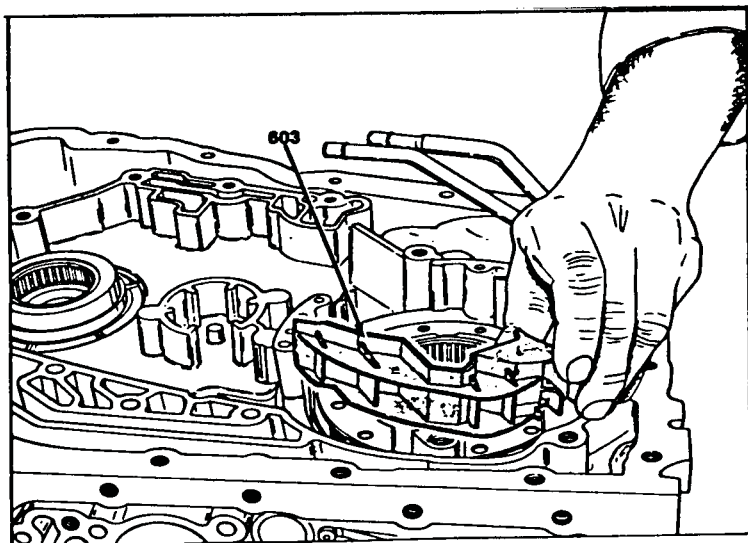

Figure 52

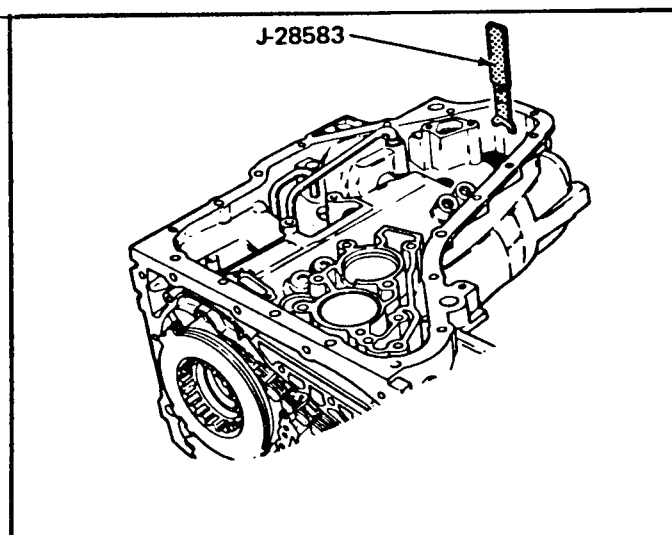

Figure 53

AUTOMATIC TRANSMISSION SERVICE GROUP

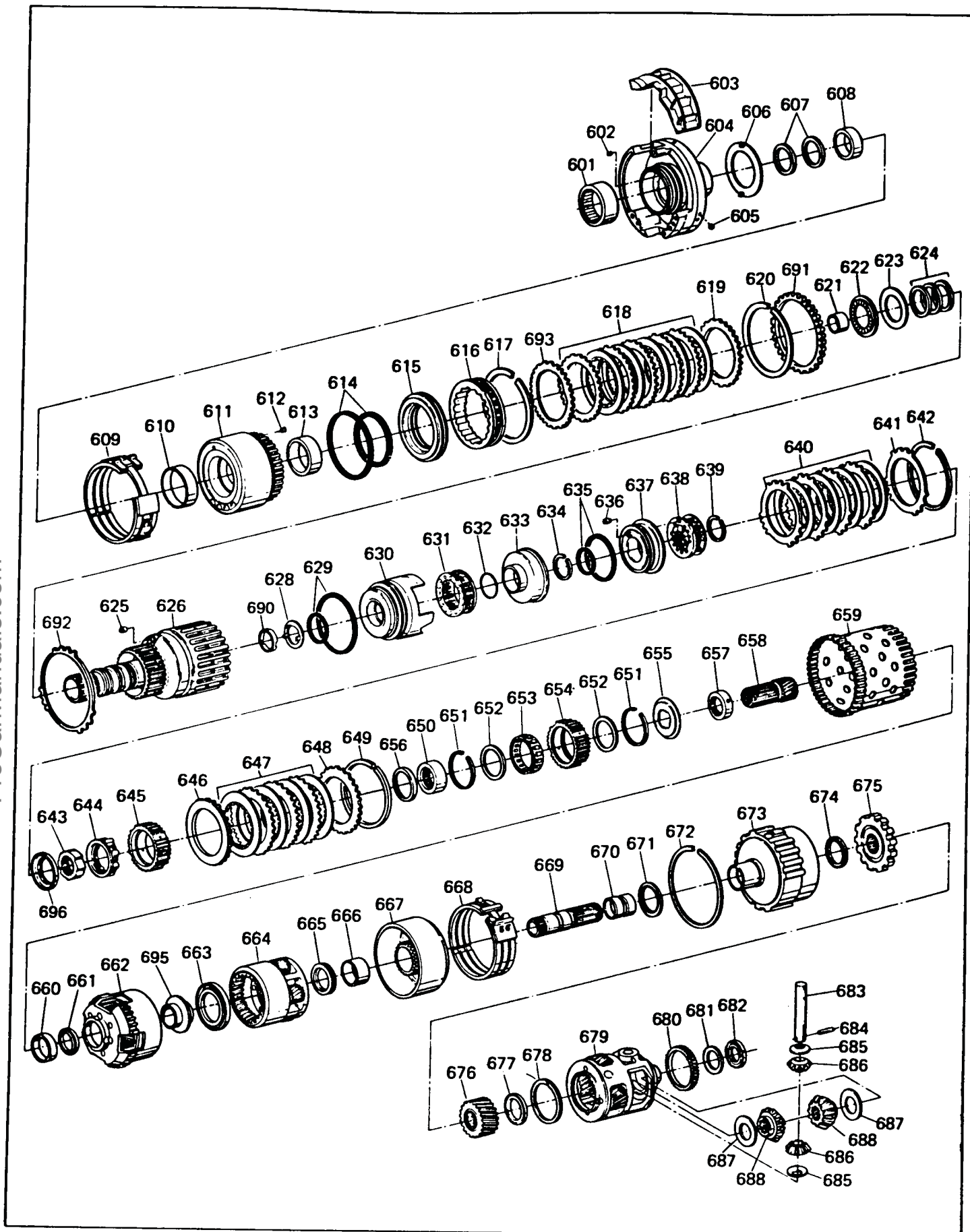

Figure 54

ILL. NO.	DESCRIPTION	ILL. NO.	DESCRIPTION
601	BEARING ASSEMBLY, DRAWN CUP	650	RACE, INPUT SPRAG INNER
602	PLUG, CUP (ORIFICED)	651	RING, SNAP (SPRAG)
603	SCOOP, CHAIN SCAVENGING	652	WEAR PLATE, INPUT SPRAG
604	SUPPORT, DRIVEN SPROCKET	653	SPRAG ASSEMBLY, INPUT CLUTCH
605	PLUG, CUP (4)	654	RACE, INPUT SPRAG OUTER
606	WASHER, THRUST (SUPPORT/2ND CLUTCH)	655	RETAINER, INPUT SPRAG
607	SEAL, "O" RING (SUPPORT/2ND CLUTCH)	657	SPACER, INPUT SUN GEAR
608	BUSHING, DRIVEN SPROCKET SUPPORT	658	GEAR, INPUT SUN
609	BAND, REVERSE	659	DRUM, REVERSE REACTION
610	BUSHING, 2ND CLUTCH FRONT	660	BUSHING, REACTION INTERNAL GEAR
611	HOUSING, 2ND CLUTCH	661	BEARING ASSEMBLY, (INPUT SUN/CARRIER)
612	RETAINER & BALL ASSEMBLY	662	CARRIER ASSEMBLY, INPUT
613	BUSHING, 2ND CLUTCH REAR	663	BEARING ASM., (INPUT/REACTION CARRIER)
614	SEALS, 2ND CLUTCH PISTON	664	CARRIER ASSEMBLY, REACTION
615	PISTON, 2ND CLUTCH	665	BEARING ASSEMBLY, (REACTION CARRIER/SUN GEAR)
616	APPLY RING & SPRING RETURN	666	BUSHING, REACTION SUN
617	RING, SNAP (2ND CLUTCH HUB)	667	GEAR & DRUM ASM., REACTION SUN
618	PLATE ASSEMBLY, 2ND CLUTCH	668	BAND, 1-2
619	PLATE, 2ND CLUTCH BACKING	669	SHAFT, FINAL DRIVE SUN GEAR
620	RING, SNAP (2ND CLUTCH BACKING)	670	BUSHING, FINAL DRIVE INTERNAL
621	BUSHING, INPUT SHAFT	671	BEARING ASSEMBLY, REACTION SUN GEAR/INTERNAL GEAR
622	BEARING, THRUST (SUPPORT/SELECTIVE THRUST WASHER)	672	RING, SNAP (INTERNAL GEAR/CASE)
623	WASHER, THRUST (SELECTIVE)	673	GEAR, FINAL DRIVE INTERNAL
624	RING, OIL SEAL (INPUT SHAFT)	674	BEARING ASM., (INT. GEAR/PARK GEAR)
625	RETAINER & BALL ASSEMBLY	675	GEAR, PARKING
626	HOUSING & SHAFT ASSEMBLY, INPUT	676	GEAR, FINAL DRIVE SUN
628	WASHER, THRUST (INPUT SHAFT/SUN)	677	BEARING, THRUST (SUN GEAR/CARRIER)
629	SEALS, INPUT CLUTCH PISTON	678	RING, SNAP (FINAL DRIVE CARRIER)
630	PISTON, INPUT CLUTCH	679	CARRIER, FINAL DRIVE
631	SPRING & RETAINER ASSEMBLY, INPUT	680	GEAR, GOVERNOR DRIVE
632	SEAL, "O" RING (SHAFT/3RD CL. HOUSING)	681	WASHER, CARRIER/CASE SELECTIVE
633	HOUSING, 3RD CLUTCH PISTON	682	BEARING ASM., (SELECTIVE WASHER/CASE)
634	RING, SNAP (SHAFT/3RD CLUTCH HOUSING)	683	SHAFT, DIFFERENTIAL PINION
635	SEALS, 3RD CLUTCH PISTON	684	PINION, DIFFERENTIAL PINION SHAFT RET.
636	RETAINER & BALL ASSEMBLY	685	WASHER, PINION THRUST
637	PISTON, 3RD CLUTCH	686	PINION, DIFFERENTIAL
638	SPRING RETAINER & GUIDE ASM., 3RD CL.	687	WASHER, DIFFERENTIAL SIDE GEAR THRUST
639	RING, SNAP (SHAFT/3RD CL. SPRING RET.)	688	GEAR, DIFFERENTIAL SIDE
640	PLATE ASSEMBLY, 3RD CLUTCH	690	SLEEVE, LOCK UP
641	PLATE, 3RD CLUTCH BACKING	691	SUPPORT, 2ND CLUTCH HOUSING
642	RING, SNAP (3RD CLUTCH BACKING PLATE)	692	PLATE, REVERSE REACTION DRUM
643	CAM, 3RD ROLLER CLUTCH	693	PLATE, 2ND CLUTCH WAVED
644	ROLLER ASSEMBLY, 3RD CLUTCH	656	DAM, INPUT SPRAG RACE LUBE
645	RACE, 3RD ROLLER CLUTCH	695	DAM, INPUT CARRIER/REACTION CARRIER
646	PLATE, INPUT CLUTCH APPLY	696	DAM, 3RD ROLLER CLUTCH
647	PLATE ASSEMBLY, INPUT CLUTCH		
648	PLATE, INPUT CLUTCH BACKING		
649	RING, SNAP (INPUT CLUTCH BACKING PLATE)		

Figure 54 LEGEND

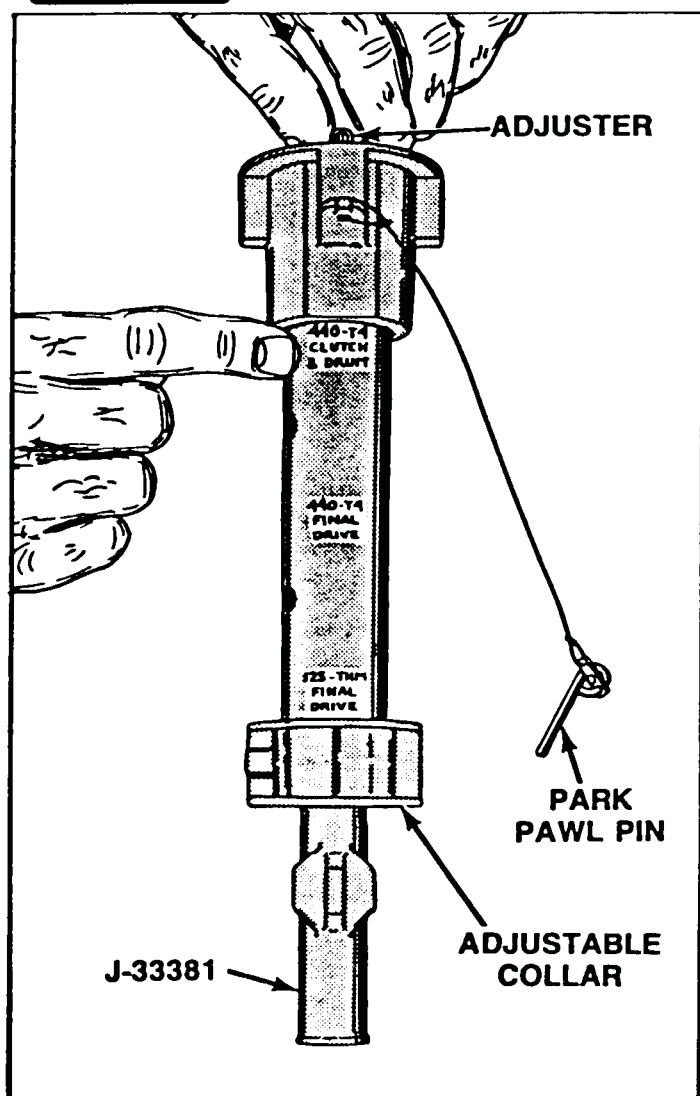

Figure 55

DRIVEN SPROCKET SUPPORT

1. Screw the two 13mm pump bolts into the driven sprocket support. One into the threaded hole by the oil feed holes and one across from it.
2. Using the pump bolts as "Handles" remove the driven sprocket support.
3. Remove thrust washer from top of sprocket support, and bottom of sprocket support.
4. Remove and discard large, steel, sealing rings.

2ND CLUTCH, INPUT HOUSING, ROLLER CLUTCH, AND SPRAG ASSEMBLY

1. Set adjustable collar on J-33381 removal tool to "440-T4 Clutch & Drum" position. Tool has three positions.
2. Install J-33381 into input housing shaft and tighten adjusting screw at top. (See Figure 55)

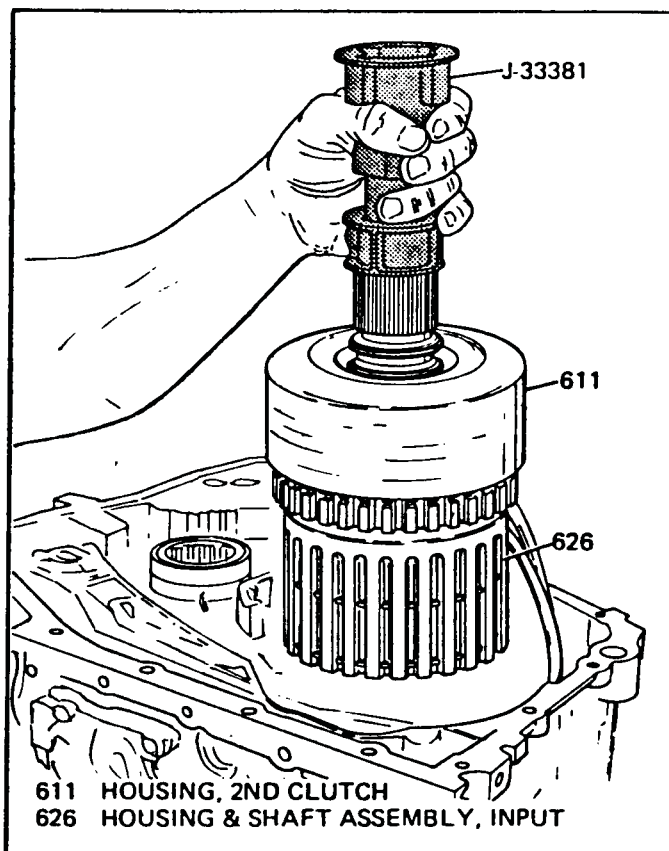

Figure 56

3. Remove the 2nd clutch housing, input/third clutch housing, sprag and roller clutch assembly, and input sun gear, as shown in Figure 56.
4. Remove reverse band.
5. Remove reverse reaction drum.
6. Remove Input carrier assembly and the thrust bearing.
7. Remove reaction carrier assembly, and the thrust bearing, which may be stuck to the carrier.
8. Remove the 1-2 drum/sun gear assembly.
9. Remove the 1-2 band assembly.
10. Remove bearing assembly from the top of final drive ring gear.
11. Remove final drive sun gear shaft.

FINAL DRIVE ASSEMBLY

1. Remove snap ring from case that is on top of the final drive ring gear.
2. Set adjustable collar on J-33381 removal tool to "440-T4 Final Drive" position.
3. Install J-33381 tool into final drive assembly and tighten adjusting screw.
4. Lift straight up to remove final drive assembly complete (See Figure 57).
5. Remove bearing and final drive selective thrust washer (May be on final drive).

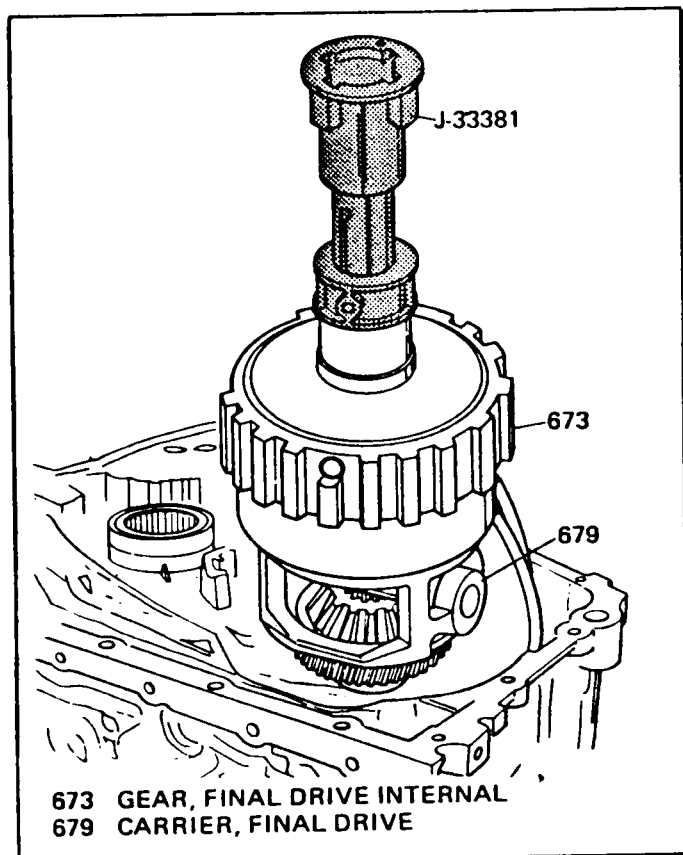

Figure 57

MANUAL SHAFT, DETENT LEVER, ACTUATOR ROD
 NOTE: DO NOT REMOVE THESE PARTS UNLESS
 REPLACEMENT IS NECESSARY.

1. Remove "Nail" (703) from case. Refer to Figure 58.
2. Remove 13mm lock nut from manual shaft.
3. Remove detent lever and actuator rod from manual shaft.
4. Remove manual shaft.
5. Remove "Roll Pin" (713) from case. Refer to Figure 58.
6. Remove actuator guide from case.
7. Remove and discard "O" ring from the actuator guide.
8. Remove manual shaft seal from case.

MANUAL SHAFT SEAL REPLACEMENT

1. Use the following procedure if manual shaft was not removed from the case.
2. Pry out old manual shaft seal with a screwdriver. Use care not to damage the case or manual shaft.
3. Lubricate manual shaft, and tap a new manual shaft seal into place with a 9/16" deep socket

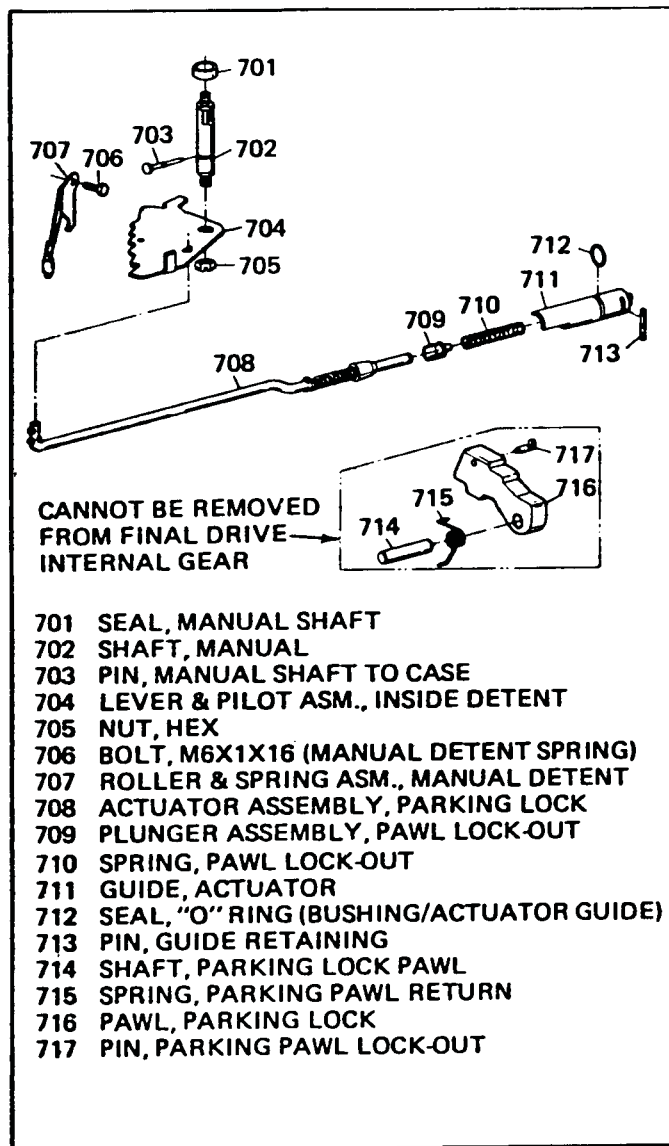

Figure 58

INSPECTION AND REASSEMBLY

CASE ASSEMBLY

1. Clean case thoroughly with solvent and dry case with compressed air.
2. Inspect the case for the following;
 - * Lug damage.
 - * Snap ring groove for damage.
 - * Damaged or interconnected oil passages.
 - * Servo bore for damage or wear.
 - * Porosity in case casting.
 - * Stripped threads in bolt holes.
 - * Case (Final Drive) bushing for wear.
 - * Vent assembly for damage.
 - * 1-2 band stop for damage. It must also protrude 9/16" thru the case. (See Figure 59).

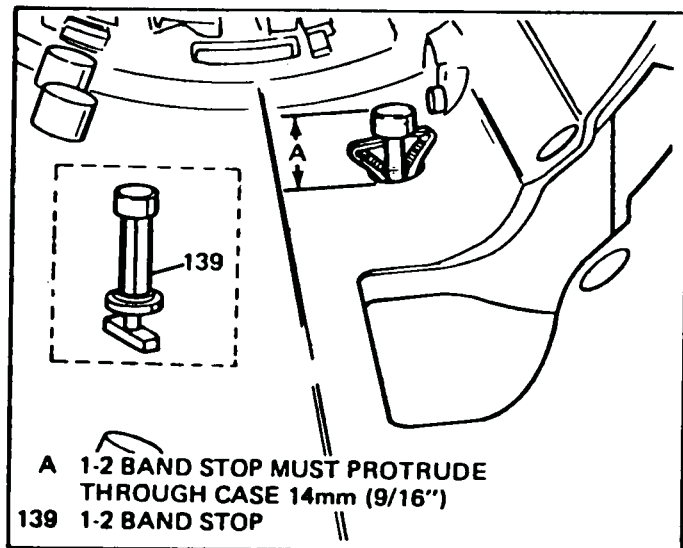

Figure 59

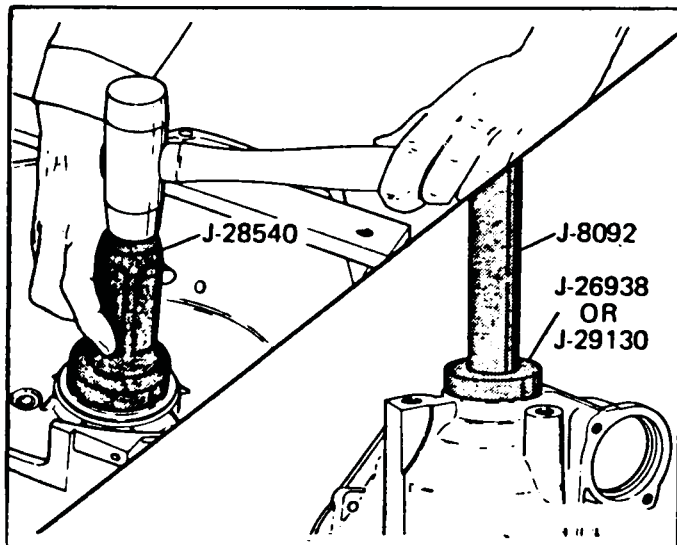

Figure 60

DRIVE SPROCKET SUPPORT

1. Inspect the following;
 - * Splines for damage or wear.
 - * Journal area for damage or wear.
 - * Bushing for damage or wear.
 - * Make sure feed holes are open.
 - * Bearing assembly for damage or wear.
2. If removal is necessary, remove the four 40 torx head bolts and remove the drive sprocket support from case. (Fig. 62)
3. After installing the drive sprocket support, torque bolts to 20 ft. lbs.
4. Install new converter seal with seal driver as shown in Figure 60.
5. Lubricate seal with petrolatum.

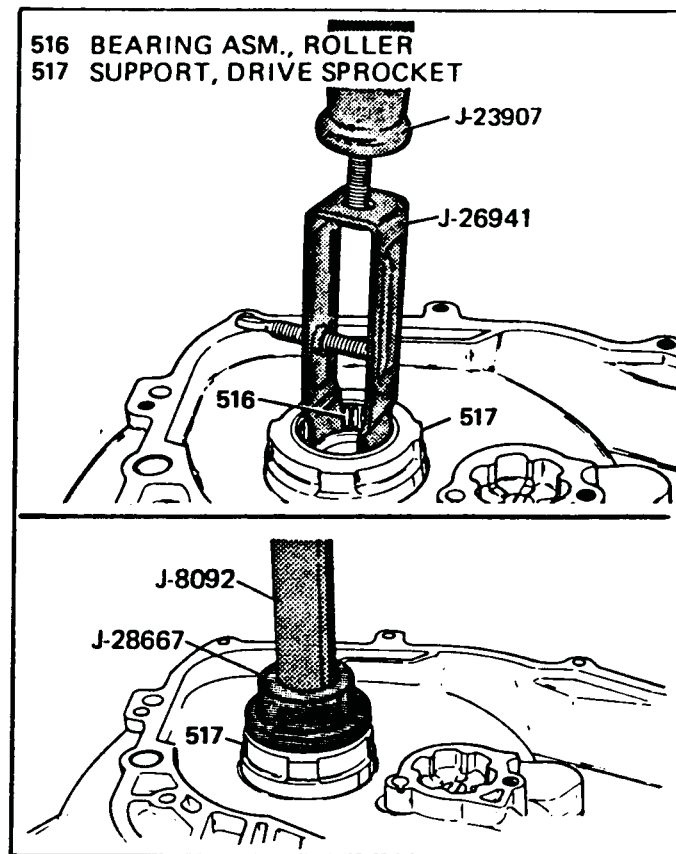

Figure 61

BEARING REPLACEMENT PROCEDURE

1. Use the bearing puller and installation tools, as shown in Figure 61, to remove and replace the drive sprocket support bearing.

BALL CAPSULE REPLACEMENT PROCEDURE

1. Flatten the dimples that retain check ball and spring in the capsule.
2. Remove check ball and spring with a pencil magnet.
3. Remove the capsule from the case with a screw extractor, with a slide hammer attached.
4. Install new capsule, OEM No. 8662839, by driving in with a 1/2" steel rod.
5. Insure that you position slot in the capsule so that it opens into the servo bore. (See Figure 63).
6. Install both servo apply and servo release pipe seals into the case, and lubricate with petrolatum.
7. Install both servo pipes into the case at this time, and re-attach the large rubber band to retain pipes.

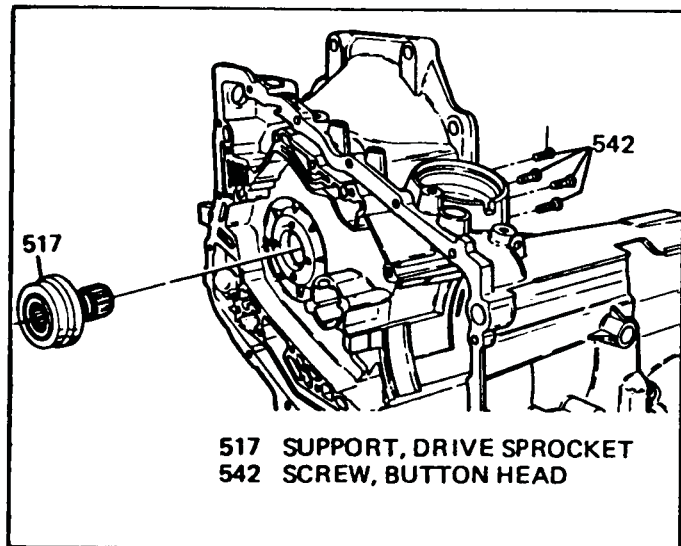

Figure 62

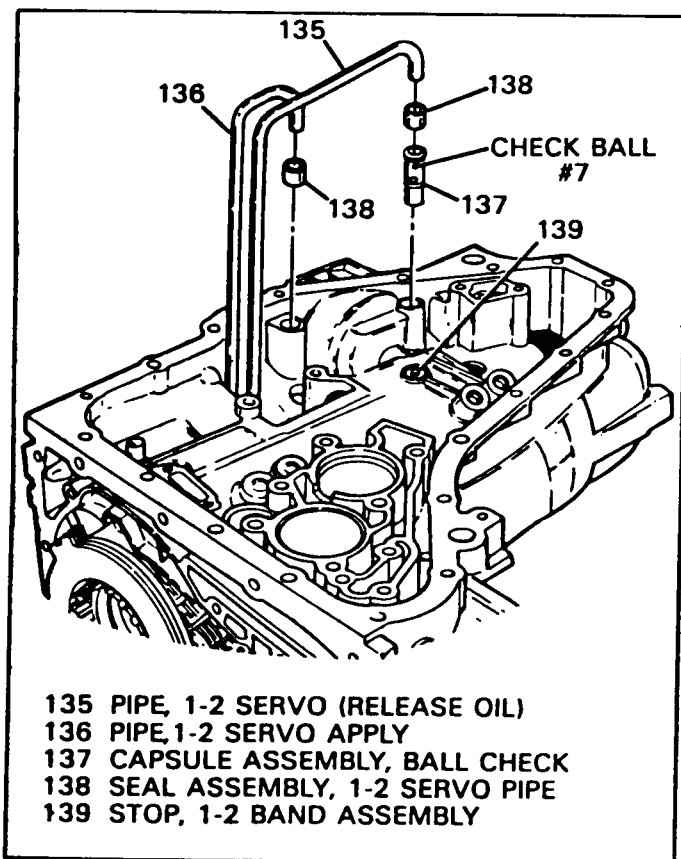

Figure 63

FINAL DRIVE ASSEMBLY

1. Remove the internal gear, thrust bearing, parking gear, and final drive sun gear (See Figure 64).
2. Inspect the following;
 - * Final drive pinions for damage or wear. Check for excessive end play using a feeler gage. End play on the pinions should be .009" - .025"(Figure 65).
 - * Internal gear for damaged teeth, and parking pawl and spring for damage.
 - * Sun gear for damaged teeth.
 - * Parking gear for damaged lugs and/or damaged splines.
 - * Thrust bearing assemblies for damage. The thrust bearing inside the final drive cannot be removed on the 3.33 ratio only.
 - * Governor drive gear for damage or excessive wear.

GOVERNOR DRIVE GEAR REPLACEMENT

1. Remove the governor drive gear with the J-8433 puller as shown in Figure 66. Place a thick flat washer on the hub to prevent damage to the final drive. See Figure 66.
2. Install new drive gear with a soft mallet to prevent damage to the gear.

DIFFERENTIAL PINION REPLACEMENT

1. Remove retaining pin with a 3/16" pin punch as shown in Figure 67.
2. Remove cross shaft.
3. Remove differential pinions, side gears, and thrust washers.
4. Inspect all parts for damage or wear.

NOTE: The dimensions on these parts on 1988 and later models changed, and will not interchange with earlier model parts.
5. Install side gears and washers into the carrier.
6. Retain washers on pinions with petrolatum and install pinions into carrier.
7. Slide cross shaft thru both pinions to align them, and then remove shaft.
8. Rotate both pinions into position, and install cross shaft thru carrier and both pinions.
9. Install the retaining pin (Figure 67).

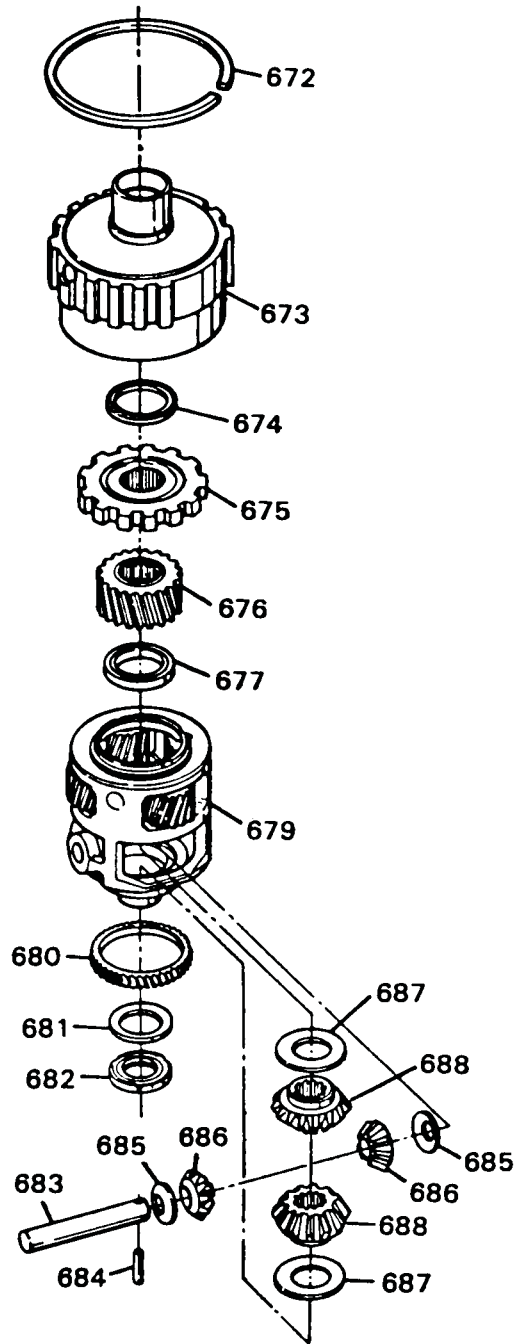

- 672 RING, SNAP (INTERNAL GEAR/CASE)
- 673 GEAR, FINAL DRIVE INTERNAL
- 674 BEARING ASSEMBLY, (INTERNAL GEAR/
PARK GEAR)
- 675 GEAR, PARKING
- 676 GEAR, FINAL DRIVE SUN
- 677 BEARING, THRUST (SUN GEAR/CARRIER)
- 679 CARRIER, FINAL DRIVE
- 680 GEAR, GOVERNOR DRIVE
- 681 WASHER, CARRIER/CASE SELECTIVE
- 682 BEARING ASM., (SELECTIVE WASHER/CASE)
- 683 SHAFT, DIFFERENTIAL PINION
- 684 PINION, DIFFERENTIAL PINION SHAFT RET.
- 685 WASHER, PINION THRUST
- 686 PINION, DIFFERENTIAL
- 687 WASHER, DIFFERENTIAL SIDE GEAR THRUST
- 688 GEAR, DIFFERENTIAL SIDE

Figure 64

- A FEELER GAGE
- B PINION, FINAL DRIVE
- 679 CARRIER, FINAL DRIVE

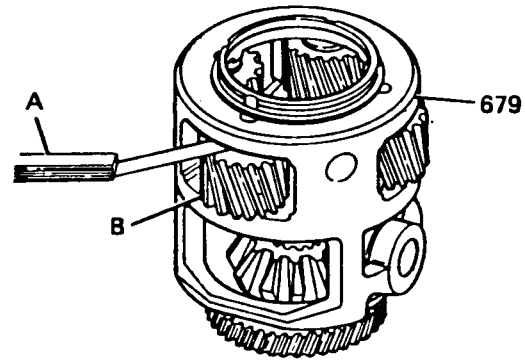
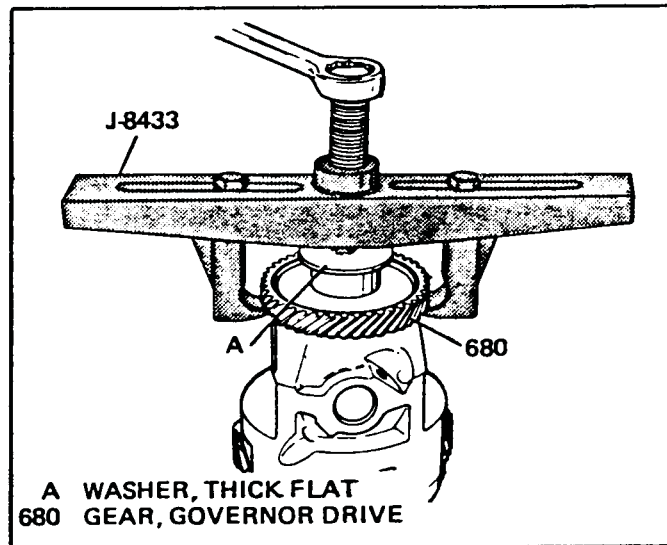

Figure 65



- A WASHER, THICK FLAT
- 680 GEAR, GOVERNOR DRIVE

Figure 66

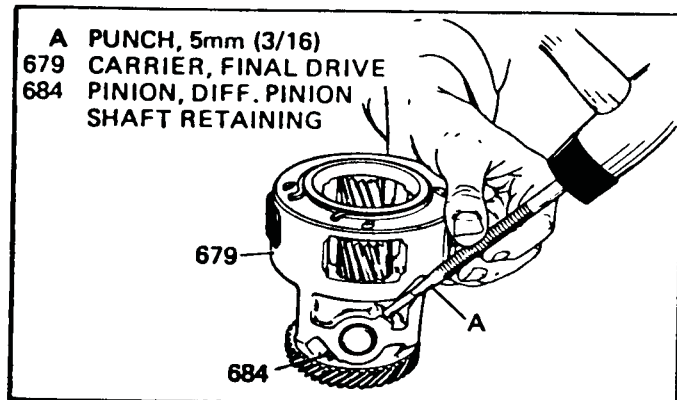

Figure 67

ASSEMBLE FINAL DRIVE

1. Install thrust bearing (677) into the carrier with the shiny side up.
2. Install final drive sun gear into the carrier with stepped side up.
3. Install park gear on top of final drive sun gear.
4. Install thrust bearing (674) onto the inside of internal ring gear with the inside tabs out. Retain thrust bearing with petrolatum.
5. Install internal gear onto carrier.
6. Install selective washer onto carrier, and retain with petrolatum.
7. Install thrust bearing onto carrier, with black side towards selective washer and retain with petrolatum.
8. Install complete final drive assembly into the case with installation tool J-33381 (See Figure 57).
9. Install snap ring into the case with open end of snap ring to the opening in the case.

FINAL DRIVE END PLAY CHECK

1. Install J-26958-10 (Same as 125) thru into final drive (See Figure 68).
2. Install dial indicator on transaxle as shown in Figure 68. Stem of indicator must contact J-26958-10.
3. Lift final drive with large screwdriver thru governor hole as shown in Figure 68, and read dial indicator.
4. Correct end play is .005" - .025". Correct as necessary using the chart in Figure 68 for selective sizes.

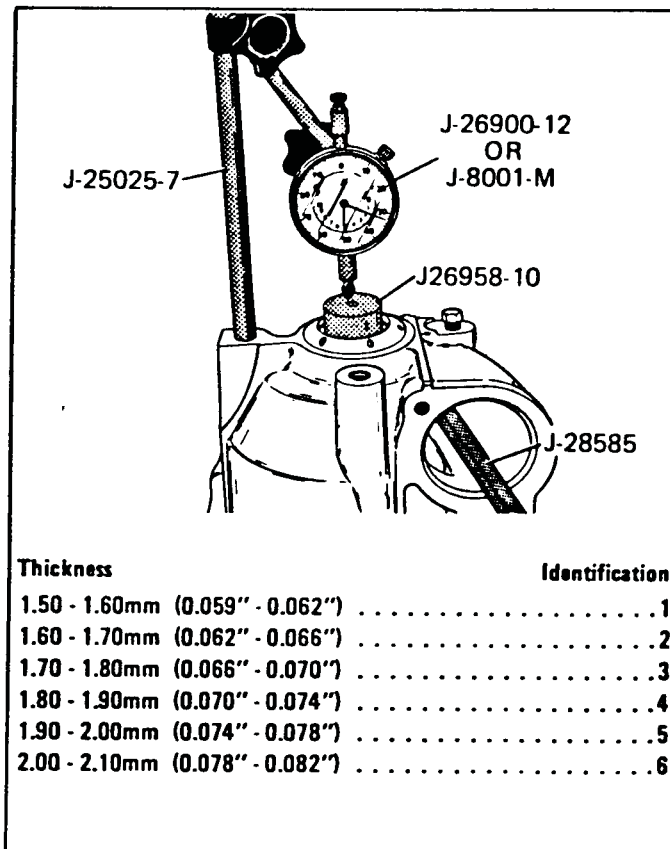

Figure 68

FINAL DRIVE SUN GEAR SHAFT

1. Install final drive sun gear shaft into final drive, long spline end first. The splines must engage both the parking gear and final drive sun gear.
2. NOTE: If plastic oil dam between the planetary carriers was broken, you will have to machine .040" from the short spline end of the final drive sun gear shaft or it will break the plastic dam again.

1-2 BAND AND DRUM ASSEMBLY

1. Install thrust bearing on top of final drive internal gear with the black side up.
2. Install the 1-2 band into the case. The band must be engaged on the case lugs.
3. Install reaction sun gear/drum assembly by rotating into the 1-2 band.

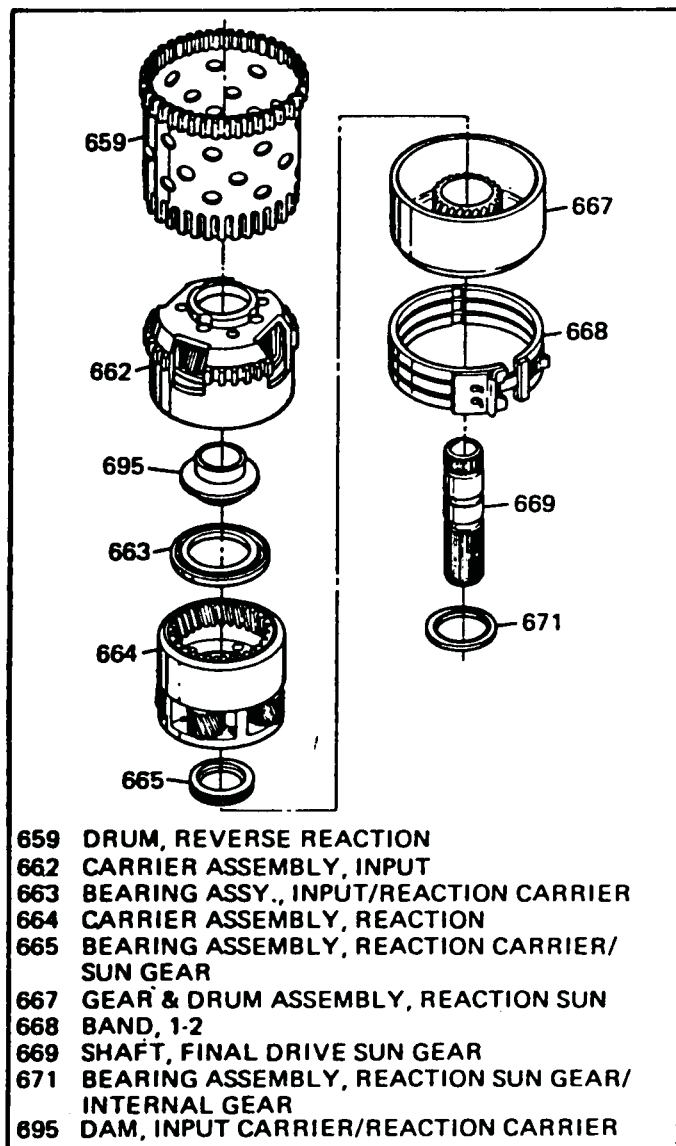

Figure 69

REACTION CARRIER AND INPUT CARRIER

1. Inspect reaction carrier for following:
 - * Internal gear damaged.
 - * Planetary pinion damage.
 - * Check pinion end play with feeler gage. End play should be .009" - .024".
2. Install bearing assembly (665) in reaction carrier, with inside race against carrier, and retain with petrolatum.
3. Install reaction carrier into transaxle, and rotate until the pinions engage with the sun gear, and splines engage with the final drive sun gear shaft.

4. Inspect input carrier for following:
 - * Internal gear for damage.
 - * Planetary pinions for damage.
 - * Thrust bearing for damage. Bearing cannot be removed from carrier.
 - * Check pinion end play with feeler gage. End play should be .009" - .024".
5. Install bearing assembly (663) in input carrier, with inside race against the carrier, and retain with petrolatum.
6. Install input carrier into transaxle, and rotate into position.
7. Refer to Figure 69.

REVERSE REACTION DRUM

1. Inspect reverse reaction drum for distortion and damaged teeth.
2. Install reverse reaction drum into the case, and ensure that the teeth engage on the input carrier.

3RD ROLLER CLUTCH, INPUT SPRAG

1. Remove 3rd roller clutch and input sprag from the input sun gear. (Figure 70).
2. Remove input sun gear retainer and spacer from sun gear (See Figure 70).
3. Disassemble 3rd roller clutch outer race and cam from roller assembly.
4. Inspect 3rd roller clutch for following:
 - * Outer race for wear or damage.
 - * Inner cam for damage or cracks.
 - * Roller assembly for damaged rollers or broken/damaged springs. Install any loose rollers by depressing spring and inserting roller.
5. Install inner cam into the 3rd roller assembly and rotate the cage so that rollers are at the lowest ramp position.
6. Install outer race over the 3rd roller assembly and rotate into position.
7. Remove inner race from input sprag.
8. Remove one snap ring from outer race using a pick or small screwdriver.
9. Remove both wear plates and input sprag assembly from outer race.
10. Inspect input sprag for following:
 - * Outer race for wear or damage.
 - * Sprag assembly for damaged sprags. If individual sprags fall out of assembly, sprag MUST be replaced.
 - * Wear plates for wear or damage.
 - * Inner race for wear or damage.

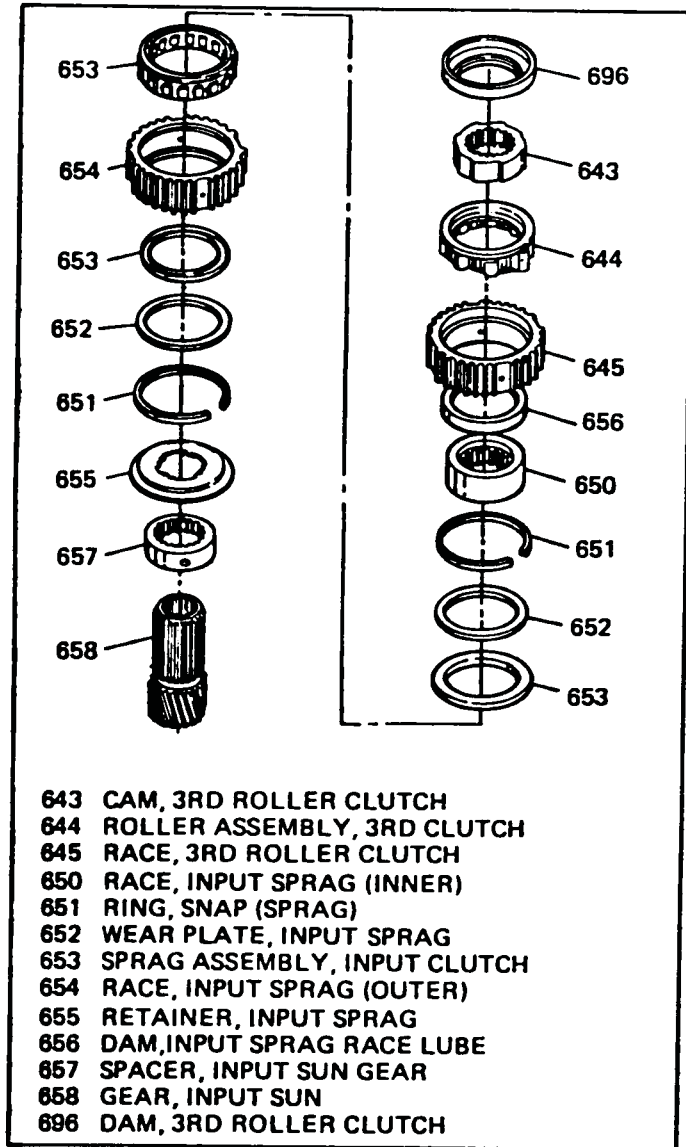

- 643 CAM, 3RD ROLLER CLUTCH
 644 ROLLER ASSEMBLY, 3RD CLUTCH
 645 RACE, 3RD ROLLER CLUTCH
 650 RACE, INPUT SPRAG (INNER)
 651 RING, SNAP (SPRAG)
 652 WEAR PLATE, INPUT SPRAG
 653 SPRAG ASSEMBLY, INPUT CLUTCH
 654 RACE, INPUT SPRAG (OUTER)
 655 RETAINER, INPUT SPRAG
 656 DAM, INPUT SPRAG RACE LUBE
 657 SPACER, INPUT SUN GEAR
 658 GEAR, INPUT SUN
 696 DAM, 3RD ROLLER CLUTCH

Figure 70

11. Install one wear plate against snap ring in the outer race.
12. Install input sprag assembly into the outer race with the notches positioned as shown in Figure 71. Make certain that the oil groove is facing up as shown in Figure 71.
13. Install wear plate and snap ring.
14. Install inner sprag race by rotating into position inside of sprag assembly.
15. Inspect input sun gear splines and sun gear for damage. Check inside diameter (Bearing Surface) for damage.

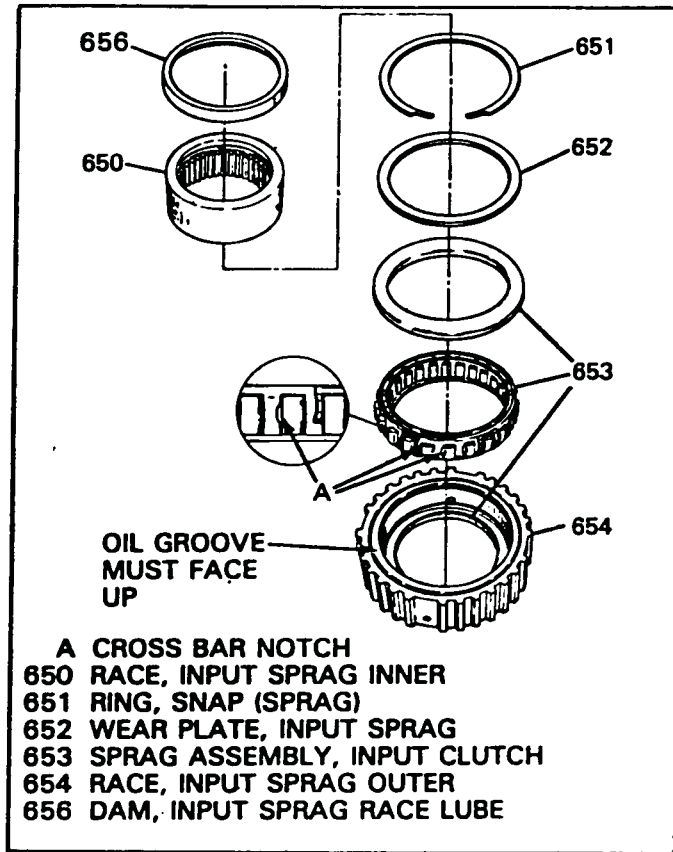

- A CROSS BAR NOTCH**
650 RACE, INPUT SPRAG INNER
651 RING, SNAP (SPRAG)
652 WEAR PLATE, INPUT SPRAG
653 SPRAG ASSEMBLY, INPUT CLUTCH
654 RACE, INPUT SPRAG OUTER
656 DAM, INPUT SPRAG RACE LUBE

Figure 71

16. Install spacer (657) onto input sun gear with the inside step towards the sun gear.
17. Install sprag retainer onto the input sun gear (See Figure 70).
18. Install input sprag assembly onto the sun gear with the oil grooves facing up.
19. Install 3rd roller clutch onto input sun gear.

FUNCTIONAL CHECK

Input sprag and 3rd roller clutch must hold as shown in Figure 73.

INPUT/THIRD CLUTCH HOUSING ASSEMBLY

1. Remove thrust washer.
2. Remove input clutch snap ring and input clutch backing plate.
3. Remove input clutches, both lined and steel plates.
4. Remove input clutch apply plate, and notice that groove on outside diameter was toward 3rd clutches.

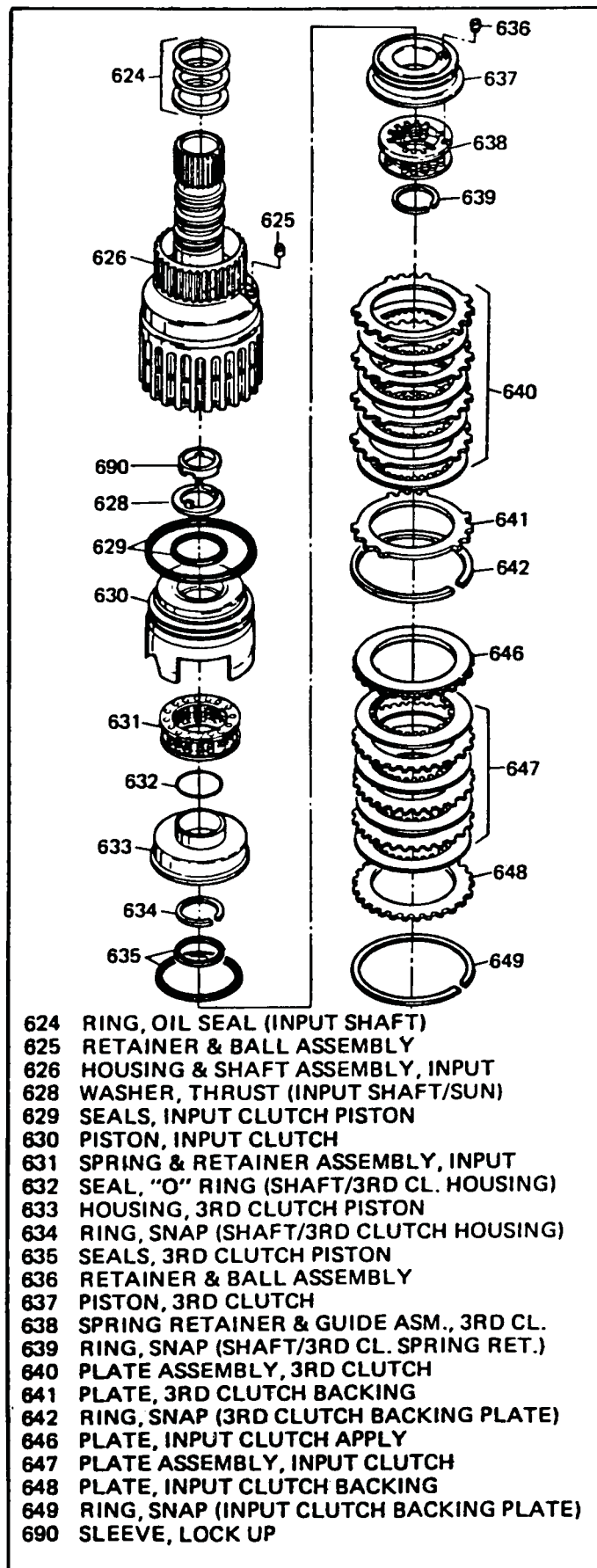

Figure 72

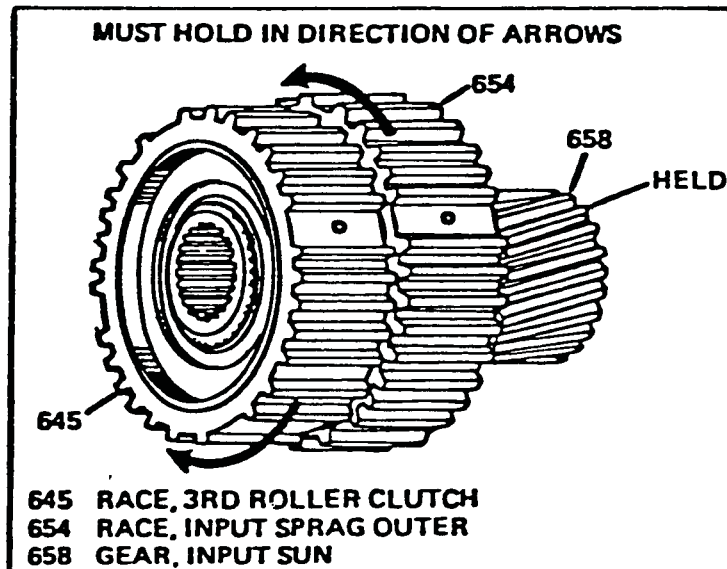

Figure 73

5. Remove 3rd clutch snap ring.
6. Remove complete 3rd clutch stack.
 NOTE: Some models have double sided 3rd clutch plates, and some models have single sided clutch plates. Make note of which you have.
7. Using a spring compressor, compress the spring retainer inside of the housing and remove the snap ring.
8. Remove the return spring assembly.
9. Remove the 3rd clutch piston from housing.
10. Remove 3rd clutch inner lip seal from the input housing shaft.
11. Compress the 3rd piston housing and remove the snap ring. Use caution not to over expand the snap ring.
12. Remove the 3rd clutch piston housing.
13. Remove "O" ring seal from input housing shaft.
14. Remove input clutch return spring Assy.
15. Remove input clutch piston.
16. Remove input clutch inner seal from input housing shaft.

INSPECTION

Inspect all parts that are shown in Figure 72 for wear or damage. Discard all rubber seals and "O" rings, and all lined clutch plates.

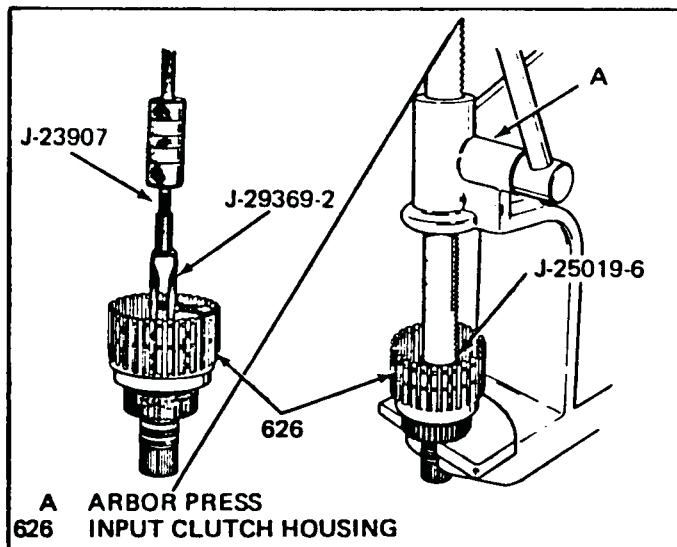

Figure 74

LOCKING SLEEVE REPLACEMENT (If Necessary)

1. Do not remove locking sleeve from the input housing unless replacement is necessary.
2. If there is a seal behind the locking sleeve, remove and discard, and DO NOT replace it.
3. Press replacement locking sleeve into the input housing with a bench press as shown in Figure 74.

INPUT HOUSING SHAFT SEAL REPLACEMENT

1. Cut the old solid seal rings with a sharp knife, to remove them from the input shaft.
2. Inspect the seal ring grooves for nicks or burrs. Use a point file if necessary to remove small burrs.
3. Adjust the J-34741-1 tool so that the bottom of the seal installer matches the bottom seal ring groove.
4. Lubricate the new solid seal ring and position it on J-34741-1 installer.
5. Using J-34741-2 over the seal protector, quickly push the seal into position on the input housing.
6. Repeat this procedure for the center seal and the top seal.
7. After all three solid seals are in place, re-size the seals with J-34741-3, gently working the tool over the seals with a twisting motion.
8. Use Figure 75 for reference.
9. You can leave the re-sizing tool in place on the input housing until you are ready to install the input housing into the transaxle, to ensure not cutting the seals.

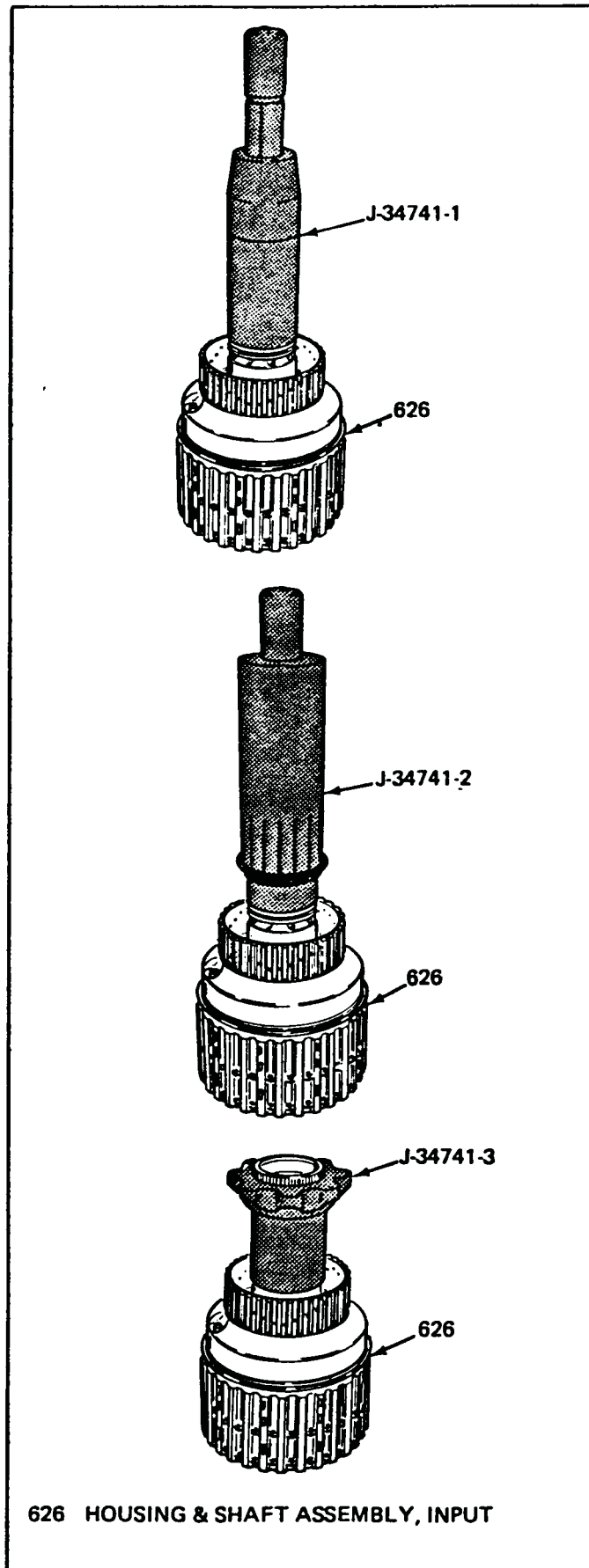

Figure 75

ASSEMBLE INPUT/3RD CLUTCH HOUSING

1. Install input clutch piston inner seal inside of housing with J-34091 lip seal installation tool. Lubricate seal with petrolatum.
2. Install outer seal on the input clutch piston and lubricate with petrolatum.
3. Install input clutch piston into the housing by rotating into position.
4. Install "O" ring seal into the groove inside of input housing and lubricate with petrolatum.
5. Install input clutch return spring on top of the input clutch piston.
6. Install third clutch piston housing into input housing by rotating into position.
7. Compress third clutch housing and install snap ring. Do not overexpand snap ring.
8. Install third clutch inner lip seal on shaft using J-34092 installer. Lubricate with petrolatum.
9. Install third clutch outer seal on the piston and lubricate with petrolatum.
10. Install third clutch piston into input housing by rotating into position.
11. Install 3rd clutch return spring Assy, compress spring and install snap ring. Do not over expand snap ring.
12. Install the third clutch plates using Figure 77 as a reference. This pack MUST start with a normal steel plate followed by a single sided, outside spline plate, with the lining up. This pack requires four outside spline plates and four inside spline plates.

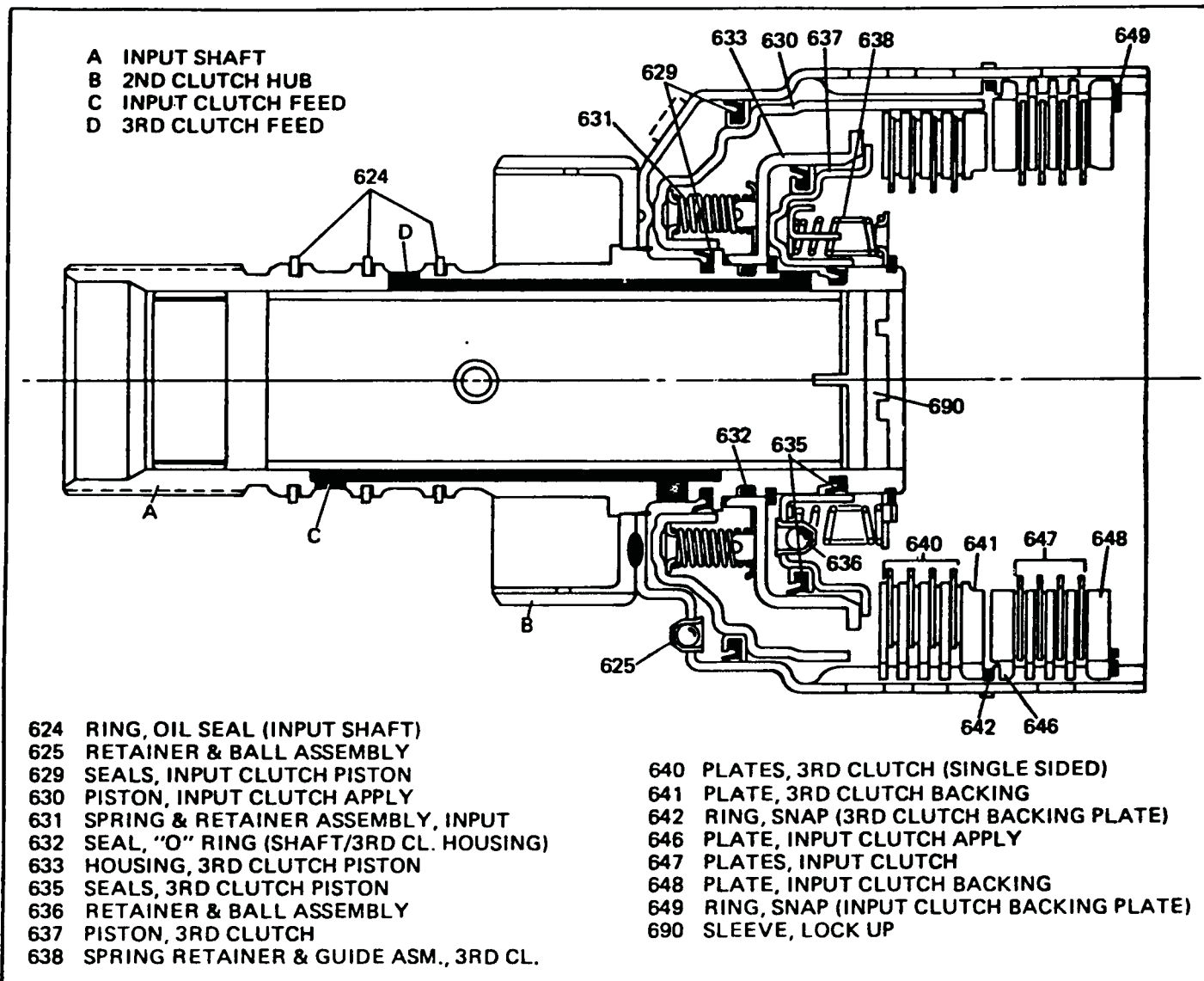

Figure 76

AUTOMATIC TRANSMISSION SERVICE GROUP



Technical Service Information

13. Install the 3rd clutch backing plate. Stepped side on the inside diameter must face up.
14. Install 3rd clutch snap ring.
15. Install the input clutch apply plate. Stepped side on the outside diameter must face down, against snap ring.
16. Install input clutch plates starting with a lined plate. This clutch pack requires 3 steel plates and 4 lined plates.
17. Install the input clutch backing plate with the "Rounded" outside diameter toward the lined plate.
18. Install input clutch snap ring.

FUNCTIONAL AIR CHECK

1. Apply air pressure to passages marked C & D and check for proper clutch application.
2. Limit air pressure to 90 PSI.

2ND CLUTCH HOUSING ASSEMBLY

1. Inspect the following:
 - * Backing plate for damage.
 - * Koline steel plates for damage or wear. If the black plating is worn off of the plates, they must be replaced.
 - * Apply ring and return spring assembly for damaged or distorted springs.
 - * Piston for damage.
 - * Housing for damage or wear in the sealing ring area, and the surface where the reverse band rides.
 - * Housing for damaged bushings.
 - * Housing for damaged teeth where the reverse reaction drum splines onto the housing.
 - * Ball capsule assembly for damage or leaking. Check with solvent. Replace as necessary.

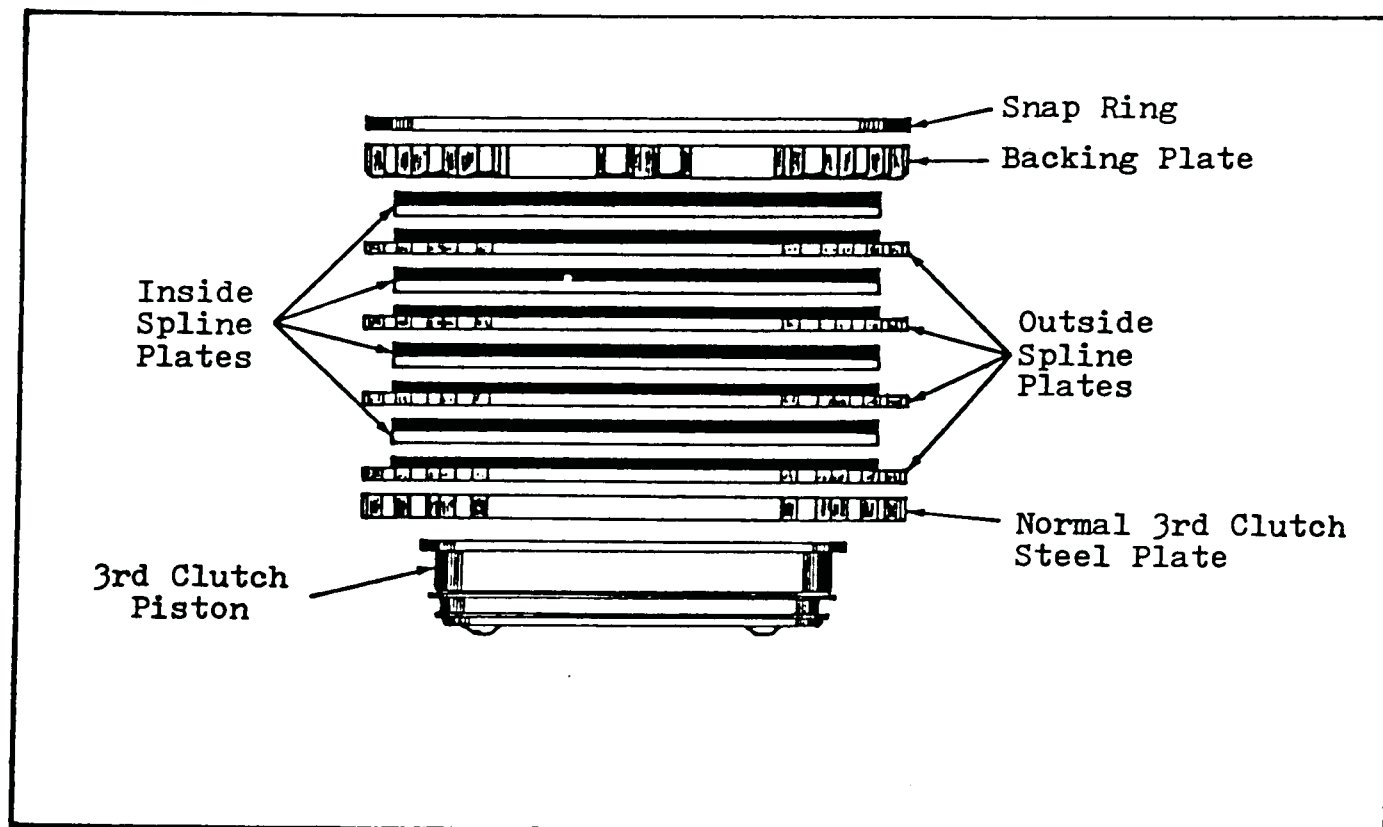

Figure 77

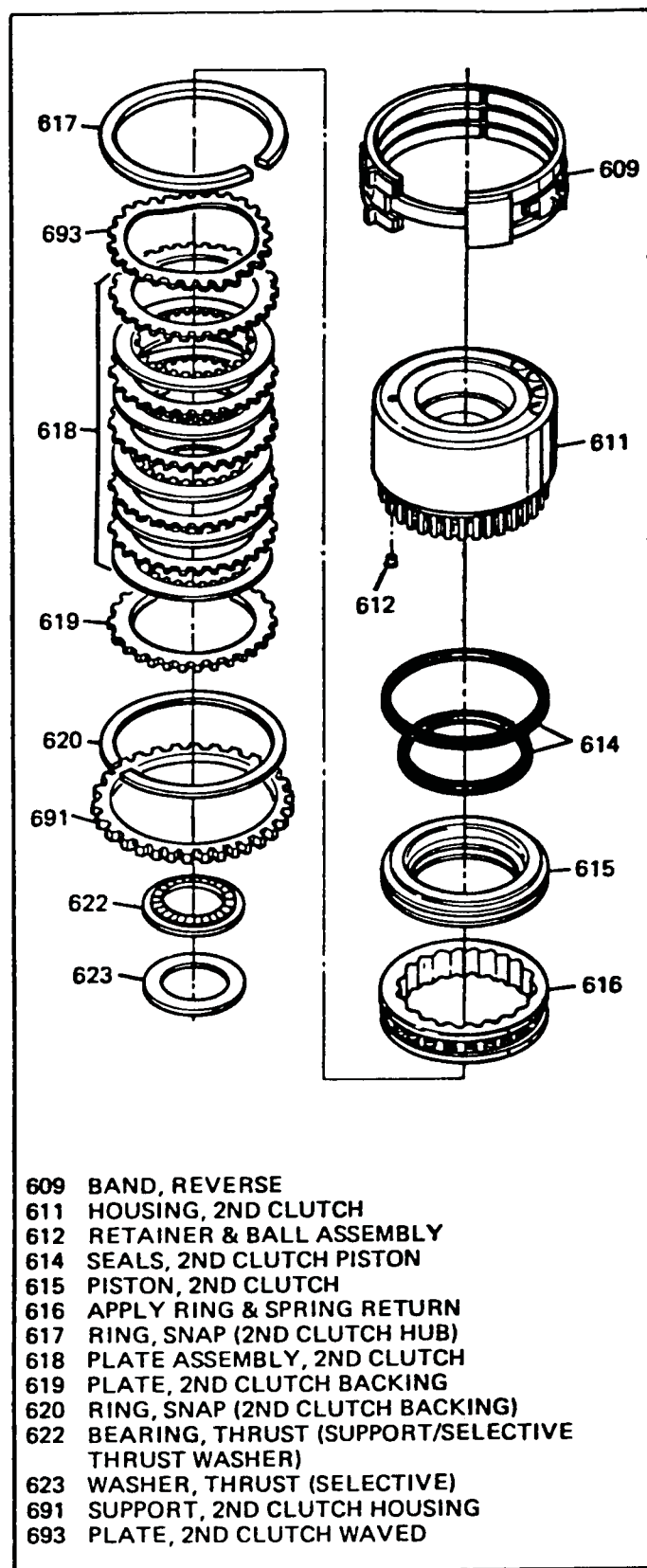

Figure 78

ASSEMBLE 2ND CLUTCH HOUSING ASSEMBLY

1. Install inner and outer lip seals onto 2nd clutch piston and lubricate with petrolatum.
2. Install piston into 2nd clutch housing by rotating into position.
3. Install apply ring and return spring assembly with the inside lip up, as shown in Figure 79.
4. Install snap ring on top of return spring assembly and pop into place with screw driver.
5. Install wave plate.
6. Install "Koline" steel plate on top of wave plate, and alternate with lined. This clutch pack MUST have the "Koline" steel plates or durability will be greatly affected.
7. Install 2nd clutch backing plate with the rounded outside edge towards the plates.
8. Install snap ring on top of backing plate.
9. Install support ring (691) on top of the snap ring and stake in place.
10. NOTE: There have been numerous changes to the 2nd clutch backing plate. See the ATSG "Update Handbook" for all details.
11. Air check 2nd clutch housing and check for proper clutch apply. Limit pressure to 90 PSI.

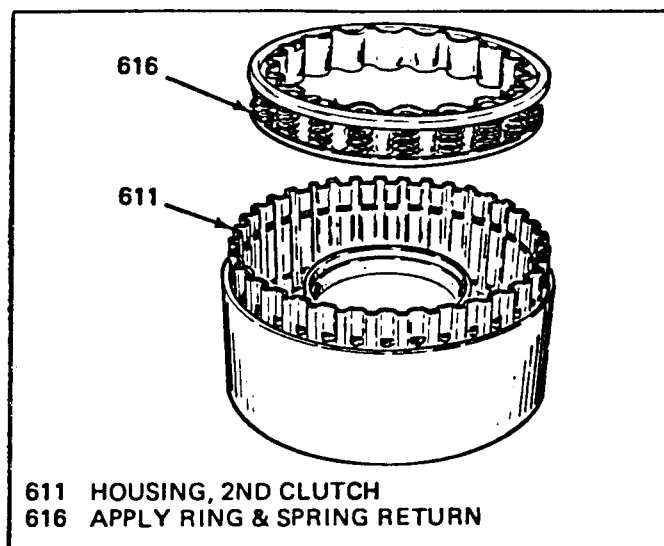

Figure 79

INPUT CLUTCH, ROLLER CLUTCH AND SPRAG ASSEMBLIES, 2ND CLUTCH HOUSING

1. Install brass thrust washer into the input housing, engaging the tangs of the washer with the slots of the locking sleeve, and retain with petrolatum.
2. Lay input housing on it's side and install 3rd roller, input sprag, and sun gear assembly by rotating into position (See Figure 80). Make certain that all clutches are engaged.
3. Stand entire assembly up on sun gear.
4. Install reverse reaction plate onto input housing as shown in Figure 80.
5. Set adjustable collar on J-33381 removal tool to "440-T4 Clutch and Drum".
6. Install J-33381 into input housing shaft and tighten adjusting screw at top, as shown in Figure 55.
7. Install input housing assembly into the case by rotating and engaging the sun gear into carrier. Also ensure that the reverse reaction plate is engaged into the reverse reaction drum.(Figure 56).
8. Remove J-33381 installation tool.
9. Install reverse band assembly into case.
10. Install 2nd clutch housing on top of input housing.
11. Rotate input housing shaft until all second clutch plates are engaged on hub, and 2nd clutch housing splines into reverse reaction drum.
12. Ensure that selective washer and bearing assembly are installed on the input housing before installing 2nd clutch housing.

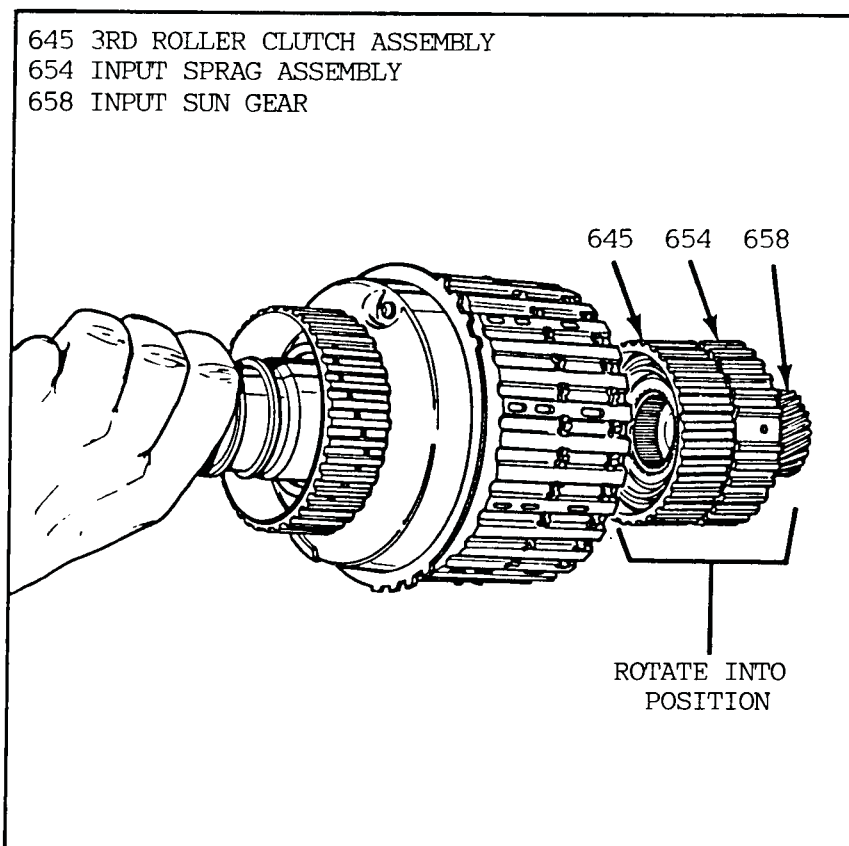

Figure 80

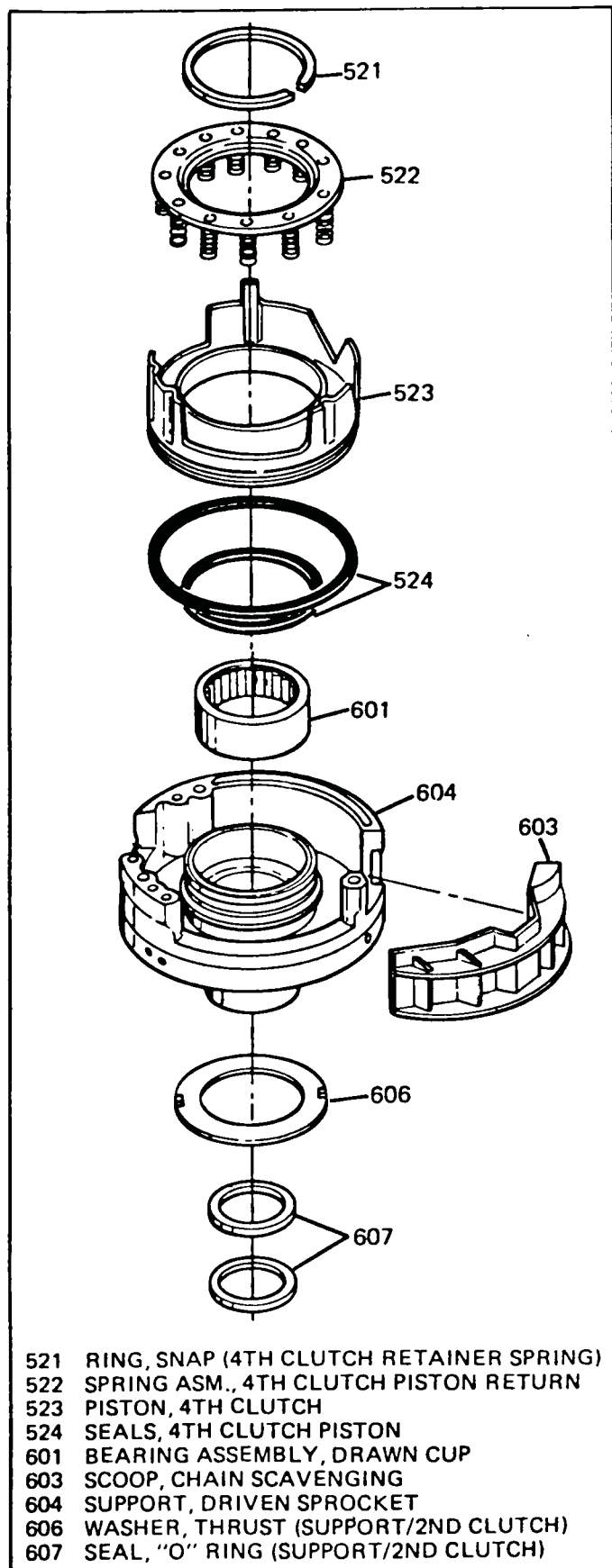

Figure 81

DRIVEN SPROCKET SUPPORT, DISASSEMBLE

1. Compress return spring assembly and remove snap ring.
2. Release compressor and remove the return spring assembly.
3. Remove the 4th clutch piston from the driven sprocket support.
4. Remove and discard the outer lip seal from the 4th clutch piston.
5. Remove and discard the inner lip seal from the driven sprocket support.
6. Inspect the following;
 - * Support for worn or damaged seal ring grooves.
 - * Support for damaged bushing.
 - * Support for sprocket bearing damage.
 - * Support for damaged piston seal surface.
 - * 4th clutch piston for damage.
 - * Spring retainer and return springs for damaged or distorted springs.
 - * Thrust washers for wear or damage.
 - * Chain scoop for damage or cracks.

NOTE: We recommend updating this driven sprocket support with the 87 style, that uses the "Vespel" sealing rings. See the ATSG "Update Handbook".

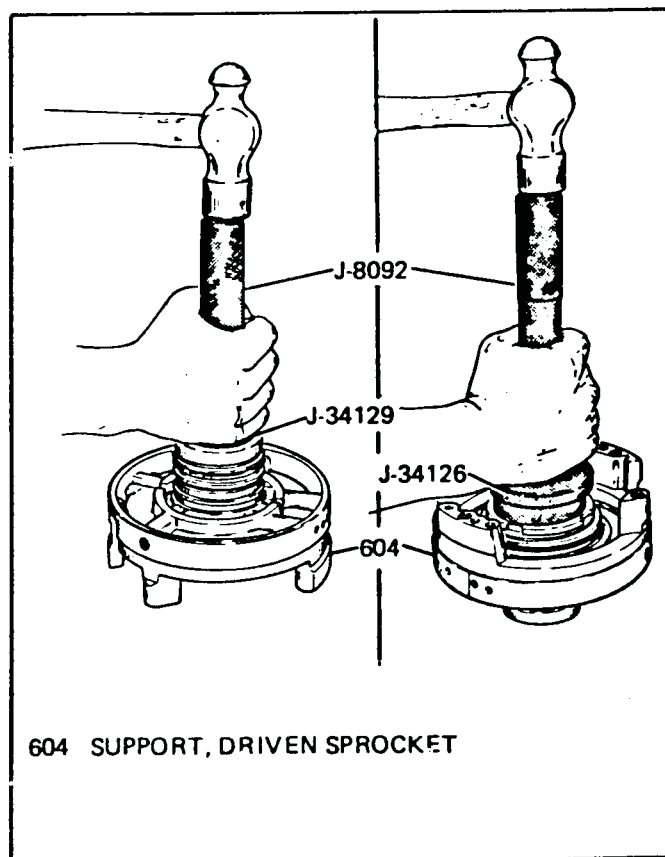

Figure 82

ASSEMBLE DRIVEN SPROCKET SUPPORT

1. Install 4th clutch inner lip seal onto the driven sprocket support, lubricate with petrolatum.
2. Install 4th clutch outer lip seal on the 4th clutch piston, and lubricate with petrolatum.
3. Install 4th clutch piston assembly into driven sprocket support, making sure that piston is oriented with support as shown in Figure 83. Use care so as not to cut outer lip seal.
4. Install return spring assembly.
5. Compress return spring assembly and install snap ring.
6. Install large sealing rings for second clutch feed onto sprocket support. When using "Vespel" sealing rings, use care so as not to twist the quad ring (Rubber) that goes beneath the "Vespel" ring.
7. Install large plastic thrust washer to bottom of sprocket support. Retain with petrolatum.
8. Lubricate inside sleeve and 2nd clutch sealing rings with petrolatum.
9. Install the long, 13mm, bolts from the pump into the sprocket support across from one another. One of them should be located by the feed holes.
10. Using the two pump bolts as handles, install the driven sprocket support with a twisting motion into case.
11. Install plastic thrust washer on top of support, retain with petrolatum.
12. Driven sprocket support should be below the level of the case surface.

SPROCKET SUPPORT BEARING REPLACEMENT

1. Use the tools shown in Figure 82 to remove and replace driven sprocket support bearing.
2. Replace as necessary.

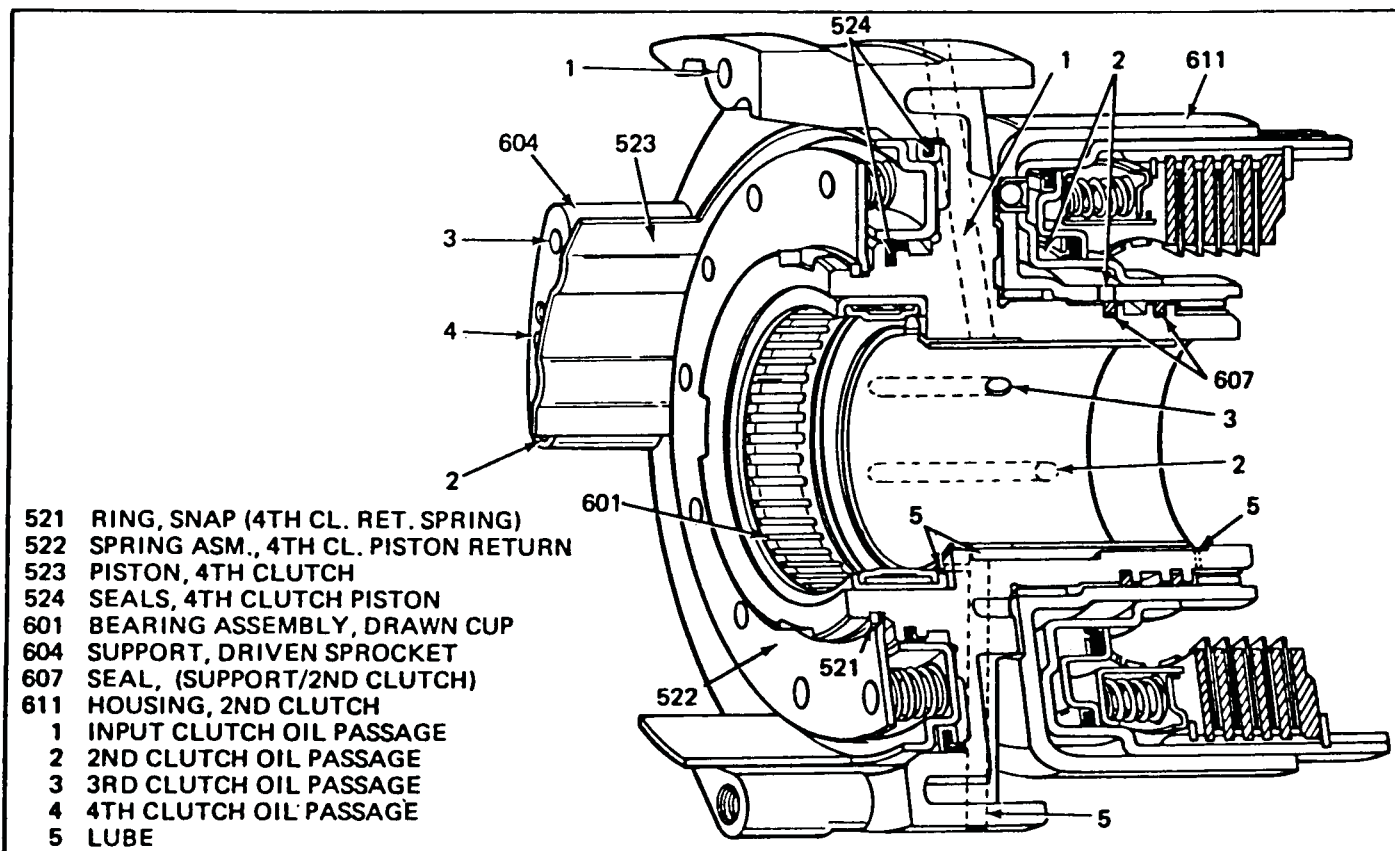

Figure 83

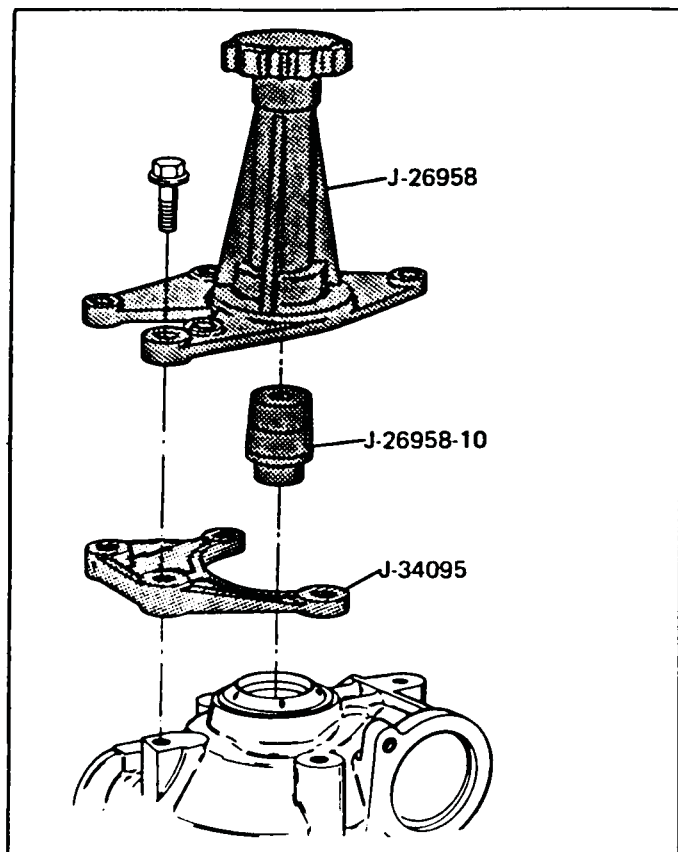

Figure 84

MEASURE INPUT END PLAY

There are two methods of measuring input end play.

METHOD I

1. Install J-26958 loading tool, J-26958-10 adapter (Both are the same as 125C) and J-34095 as shown in Figure 84.
2. Tighten loading tool to remove all end play from final drive.
3. Install J-33386, then measure with the washer as shown in Figure 85 for proper washer selection.
4. If a .006" feeler gauge or larger can be inserted between thrust washer and tool, use next size thicker thrust washer.
5. Use the chart in Figure 85 for proper thrust washer selection.

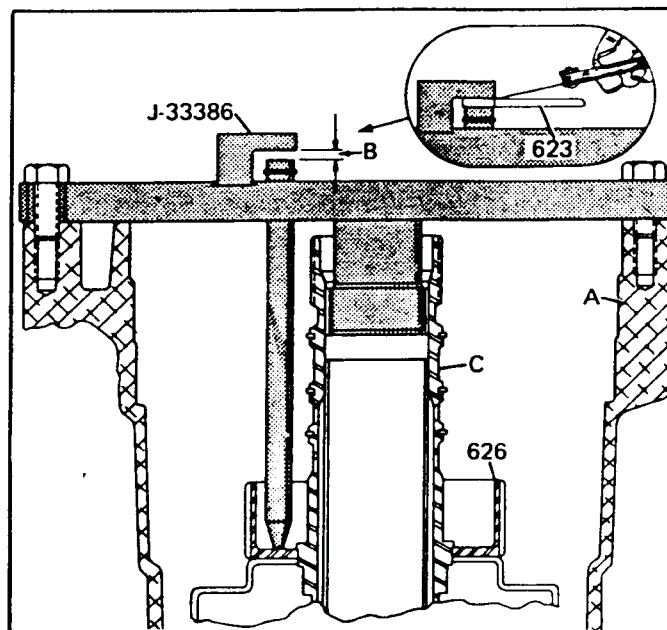

- A CASE
- B INSERT SELECTIVE THRUST WASHER TO DETERMINE PROPER SIZE
- C INPUT SHAFT
- 623 WASHER, THRUST (SELECTIVE)
- 626 HOUSING & SHAFT ASSEMBLY, INPUT

If a .152 mm (.006") feeler gauge or larger can be inserted between thrust washer and tool, use next size larger thrust washer.

GUIDE FOR SELECTING THRUST WASHER

I.D. NO.	DIMENSION	COLOR
1	2.90 - 3.00	ORANGE/GREEN
2	3.05 - 3.15	ORANGE/BLACK
3	3.20 - 3.30	ORANGE
4	3.35 - 3.45	WHITE
5	3.50 - 3.60	BLUE
6	3.65 - 3.75	PINK
7	3.80 - 3.90	BROWN
8	3.95 - 4.05	GREEN
9	4.10 - 4.20	BLACK
10	4.25 - 4.35	PURPLE
11	4.40 - 4.50	PURPLE/WHITE
12	4.55 - 4.65	PURPLE/BLUE
13	4.70 - 4.80	PURPLE/PINK
14	4.85 - 4.95	PURPLE/BROWN
15	5.00 - 5.10	PURPLE/GREEN

Figure 85

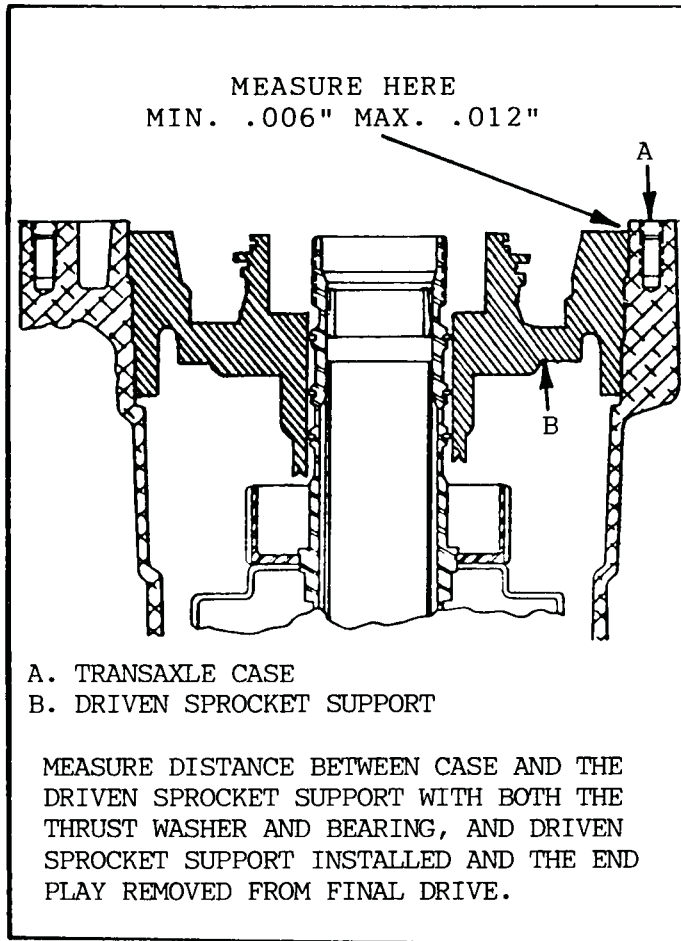

Figure 86

METHOD II

1. Install J-26958 loading tool, J-26958-10 adapter (Both are the same as 125C) and J-34095 as shown in Figure 84.
2. Tighten loading tool to remove all end play from final drive.
3. Install selective washer and bearing.
4. Install driven sprocket support.
5. Measure with feeler gauge and straight edge, the distance between the driven sprocket support and the case.
NOTE: DRIVEN SPROCKET SUPPORT MUST ALWAYS BE BELOW THE CASE SURFACE.
6. Measurement should be, minimum .006" and maximum .012".
7. Use the chart in Figure 85 for proper thrust washer selection.

DRIVE LINK ASSEMBLY AND SPROCKETS

Inspect the following:

1. Drive and driven sprockets;
 - * For damaged or worn teeth.
 - * For damaged bearing surfaces.
 - * For damage to splines.
2. Thrust washers for damage or wear.
3. Chain for excessive wear or damage.
4. Turbine shaft;
 - * For damaged bushing journals.
 - * For damage to splines.
 - * For internal bushing leakage or cracks.
5. Output shaft for;
 - * Snap ring groove damage.
 - * Damage to splines.
 - * Damage to bushing journals.
 - * Damage to bearing.

TURBINE SEAL REPLACEMENT PROCEDURE

1. Remove old seals by cutting with a knife.
2. Place J-29569-1 or J-29829-1 over the turbine shaft as shown in Figure 88, and coat with petrolatum.
3. Slide the seals into position in the appropriate grooves.
4. Remove the installation tool.
5. Re-size seals with J-29569-2 or J-29829-2, as shown in Figure 88.
6. These tool numbers are the same as the 125C tools.

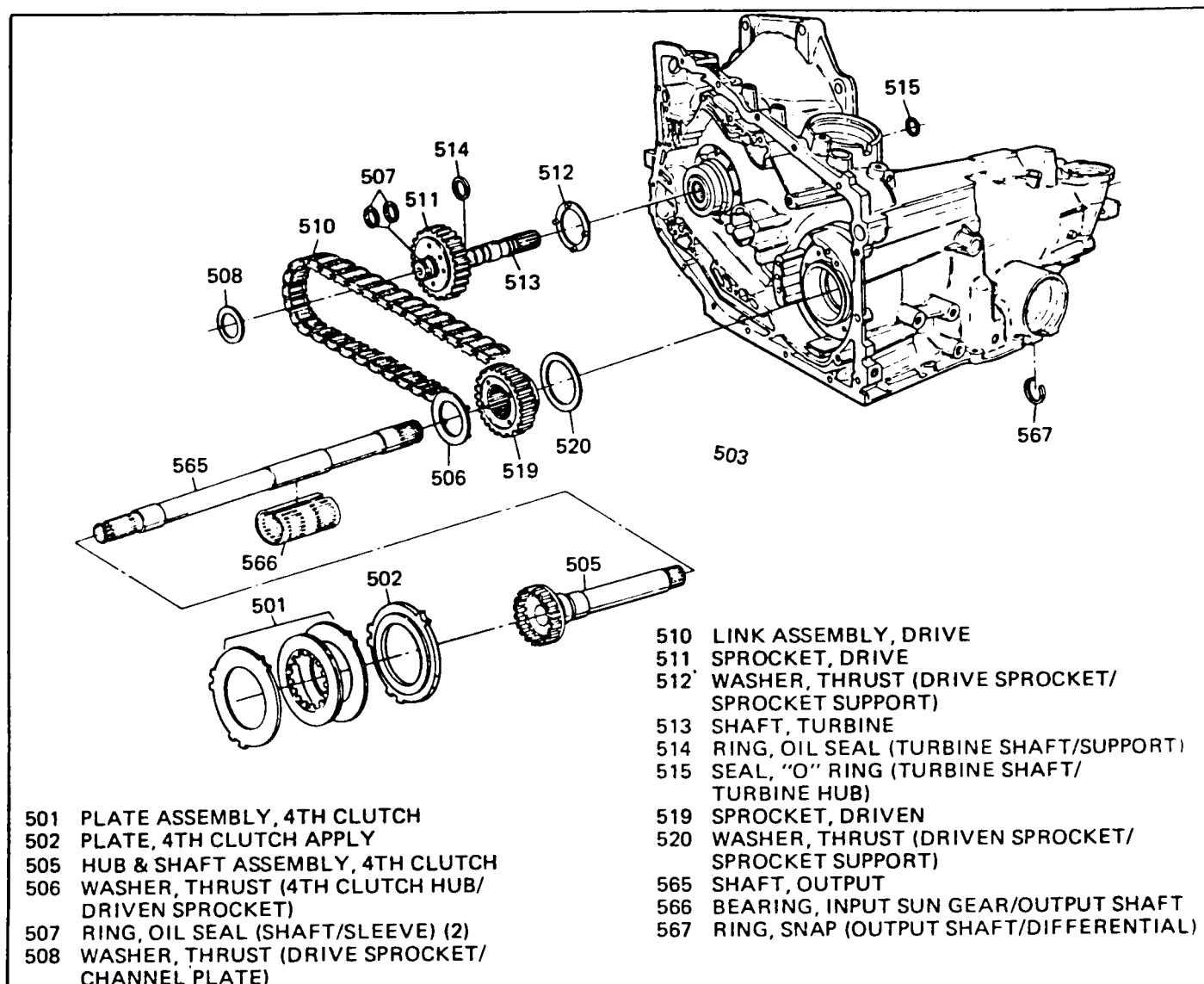

Figure 87

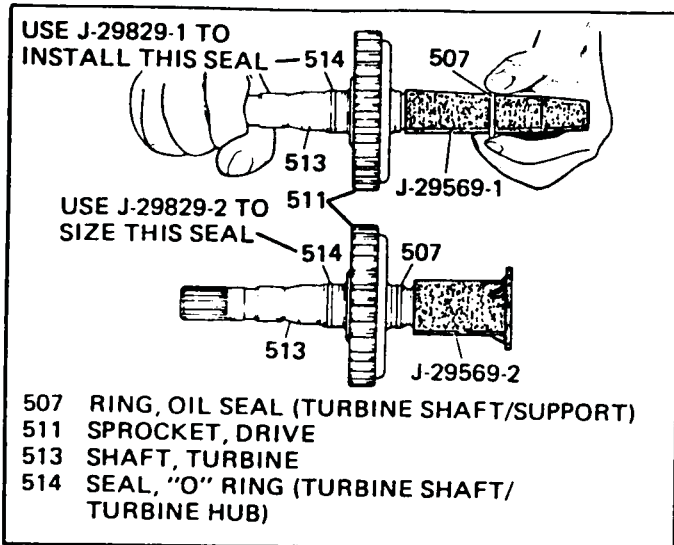

Figure 88

INSTALL CHAIN AND SPROCKET ASSEMBLY

1. Install thrust washer into front side of drive sprocket and retain with petrolatum.
2. Insert both drive and driven sprockets into chain assembly, making sure that black link on chain will be up after installation.
3. Ensure that plastic washer on top of driven sprocket is in place.
4. Install chain and sprocket assembly into position as shown in Figure 89. Black link must be up.
5. Install output shaft and bearing Assy.
6. Install "C" clip onto output shaft thru final drive opening.
7. Push "C" clip onto output shaft with J-28583 tool, or small screw driver.
8. Install thrust washer on top of driven sprocket and retain with petrolatum.
9. Install 4th clutch hub and shaft thru driven sprocket and rotate into place.
10. Install the 4th clutch apply plate, making sure that tabs are properly aligned.
11. Install one 4th clutch steel plate, and make sure that tabs are properly aligned.
12. Install 4th clutch lined plate over the 4th clutch hub with teeth engaged on hub.
13. Install another 4th clutch steel plate, making sure tabs are properly aligned.
14. Make sure that chain scoop is still fully in position.

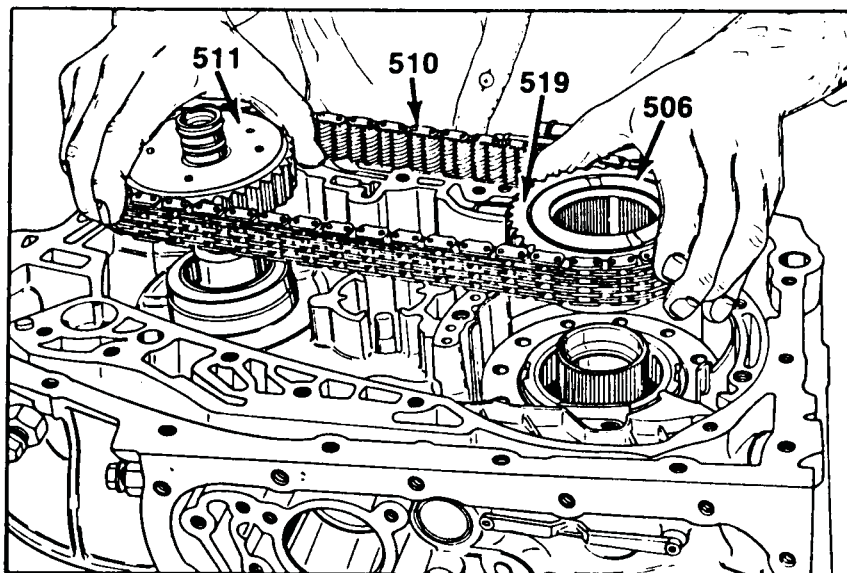
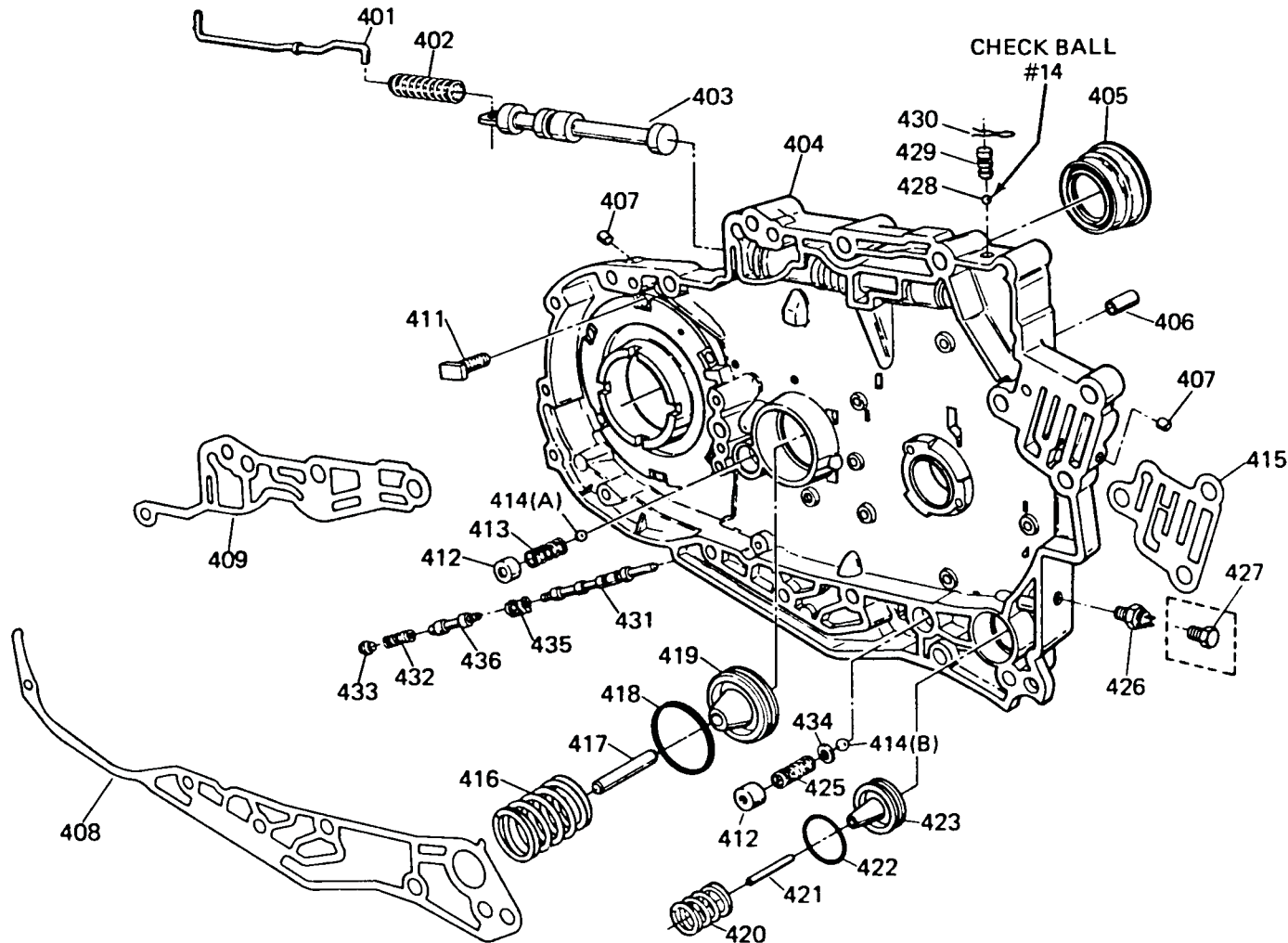

Figure 89



- | | |
|--|--|
| 401 LINK, MANUAL VALVE | 419 PISTON, INPUT CLUTCH ACCUMULATOR |
| 402 SPRING, ROD END RETAINING (MANUAL VALVE) | 420 SPRING, CONV. CLUTCH ACCUMULATOR |
| 403 VALVE, MANUAL | 421 PIN, CONVERTER CLUTCH ACCUMULATOR |
| 404 CHANNEL PLATE | 422 SEAL, CONVERTER CLUTCH ACCUMULATOR |
| 405 SEAL ASSEMBLY, AXLE OIL | 423 PISTON, CONV. CLUTCH ACCUMULATOR |
| 406 SLEEVE, CONTROL BODY ALIGNMENT | 425 SPRING, CONVERTER CLUTCH BLOW-OFF |
| 407 PLUG, CUP | 414B BALL, CONVERTER CLUTCH BLOW-OFF |
| 408 GASKET, CHANNEL PLATE (LOWER) | 426 SWITCH ASSEMBLY, TEMPERATURE (VISCOSUS ONLY) |
| 409 GASKET, CHANNEL PLATE (UPPER) | 427 PLUG, PIPE (ALL BUT VISCOSUS) |
| 411 STUD, M6X1X18.1 CHANNEL PLATE SIDE COVER (6) | 428 BALL, CHECK (#14 DETENT MODULATOR) |
| 412 PLUG, CUP (2) | 429 PLUG, BALL CHECK SEAT |
| 413 SPRING, LOW BLOW-OFF | 430 RETAINER, SPRING CLIP |
| 414A BALL, LOW BLOW-OFF | 431 VALVE, 3-2 LINE CONTROL PRIMARY |
| 415 GASKET, MODULATOR PORT | 432 SPRING, 3-2 LINE CONTROL |
| 416 SPRING, INPUT CLUTCH ACCUMULATOR | 433 PLUG, 3-2 LINE CONTROL |
| 417 PIN, INPUT CLUTCH ACCUMULATOR | 434 SEAT, SPRING |
| 418 SEAL, RING (INPUT CLUTCH ACCUMULATOR) | 435 RETAINER, 3-2 LINE CONTROL |
| | 436 VALVE, 3-2 LINE CONTROL SECONDARY |

Figure 90

AUTOMATIC TRANSMISSION SERVICE GROUP



Technical Service Information

INSTALL CHANNEL PLATE

1. Inspect the following:
 - * Manual valve for nicks or damage.
 - * Manual valve link and spring for damage.
 - * Input clutch accumulator piston and pin for damage.
 - * Converter clutch accumulator piston and pin for damage.
 - * TCC accumulator and input clutch accumulator springs for damage.
 - * TCC blow off ball and spring for damage.
 - * Low blow off ball and spring for damage.
 - * 3-2 line control valves, clip, and spring for damage or breakage.
2. Install new axle oil seal into channel plate.
3. Install new seal on input accumulator piston, and install piston into the channel plate.
4. Install input accumulator piston pin and retain with petrolatum.
5. Install new seal on TCC accumulator piston, and install piston into the channel plate.
6. Install TCC accumulator piston pin and retain with petrolatum.
7. ENSURE THAT BOTH PISTONS AND PINS ARE THE LATEST DESIGN. SEE THE ATSG "UPDATE HANDBOOK"
8. Install bearing onto channel plate by snapping into place.
9. Install thrust washer onto channel plate, and retain with petrolatum.
10. Install channel plate gaskets, and the modulator port gasket onto the case, and retain with petrolatum.
11. Install both accumulator springs in case.
12. Make sure driven sprocket support is aligned properly. Lube hole in support must align with hole in bottom of case.
13. Install channel plate on to case.
14. Install bolts in the proper locations, and torque as specified in Figure 91.
15. Connect the manual valve to manual valve link.
16. Install oil weir, see Figure 91.
17. Install detent spring and roller assembly.
18. Install 8 steel check balls into channel plate in the locations shown in Fig. 92
19. Install channel plate to spacer plate gasket.

20. Install spacer plate and verify that thermo element is in proper position. See Figure 93 for proper position of thermo element.
21. Install spacer plate to valve body gasket.
22. Install TCC screen and orifice Assy, in the location shown in Figure 42.
23. Install valve body alignment sleeve in the location shown in Figure 42.

VALVE BODY ASSEMBLY

1. Thoroughly clean complete valve body assembly in clean solvent, and move all valves with a pick or small screw driver to insure that any dirt or debris is dislodged.
2. Dry with compressed air.
3. Position on a clean surface.
4. Remove valve trains, one at a time, beginning in one corner. Some valves are under spring pressure, so cover the bores when the retainer is removed.
5. Valves, springs, and bushings should be laid out on a clean surface EXACTLY THE WAY THEY ARE REMOVED. Use Figures 95 and 96 for proper position.
6. Clean all valves, springs, and bushings in clean solvent, and dry using compressed air.
7. Inspect all valves and bushings for scoring, nicks, scratches, cracks.
8. Inspect all springs for damaged or distorted coils.
9. Inspect valve body casting for damage.
10. Inspect valve body bearing for damage. Replace as necessary.
11. Re-assemble valve body using Figures 95 and 96 for reference.
12. Install check balls into valve body using Figure 98 for location. 1985 and 85 1/2 are different.
13. Install servo pipe seals.
14. Install complete valve body assembly on channel plate and torque bolts to specification using Figure 99.
15. Insure that oil pump drive shaft turns freely.

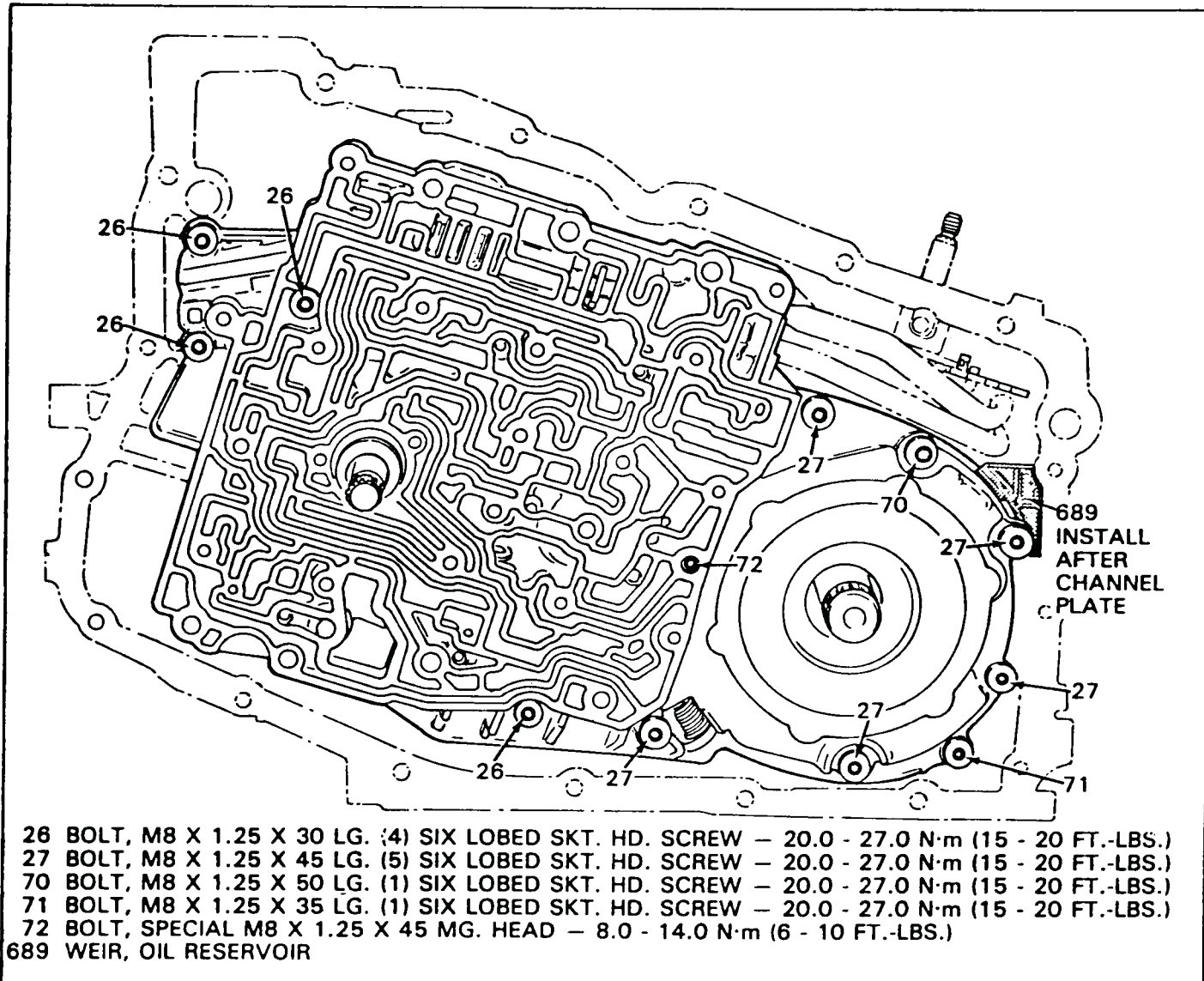

Figure 91

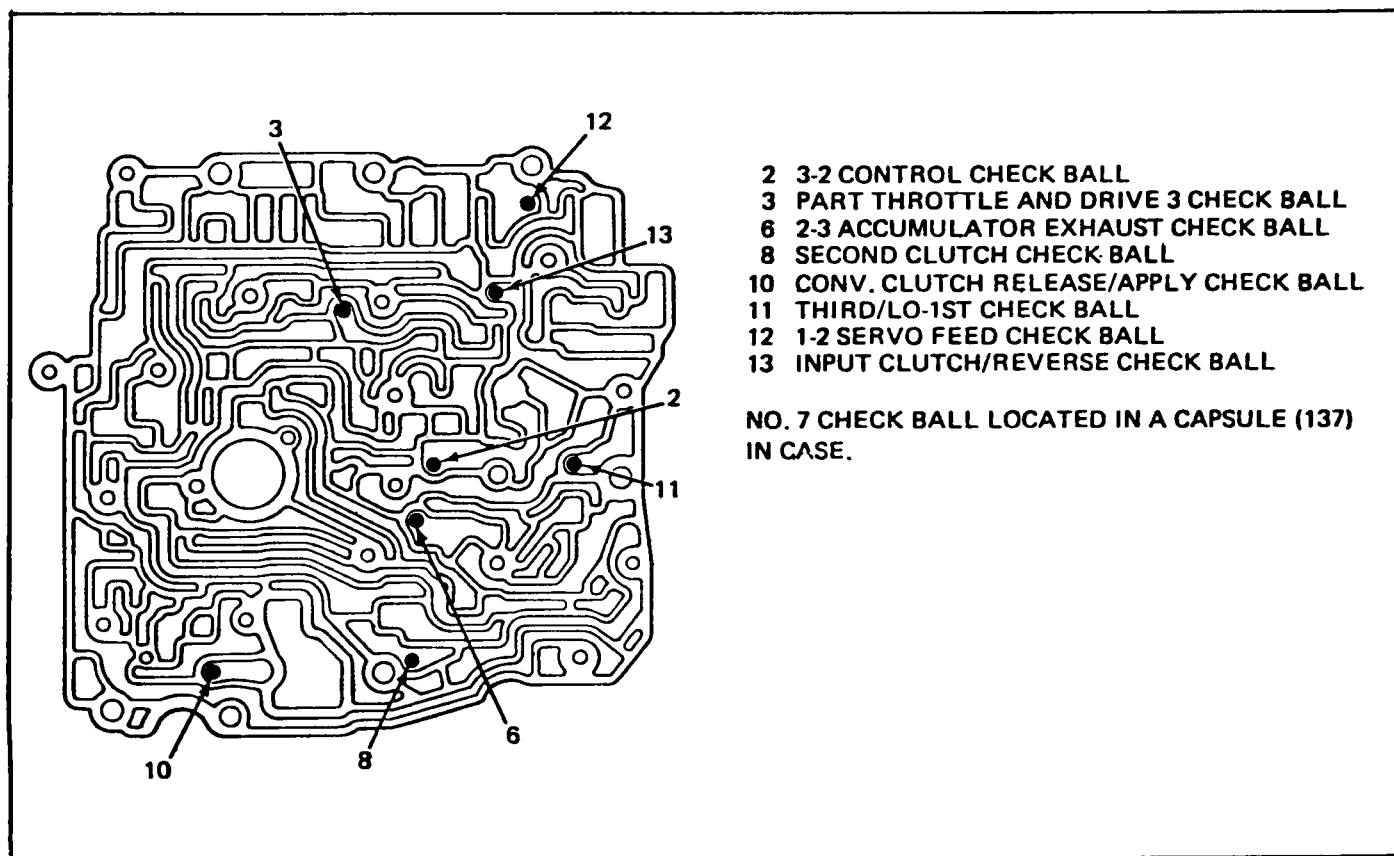

Figure 92

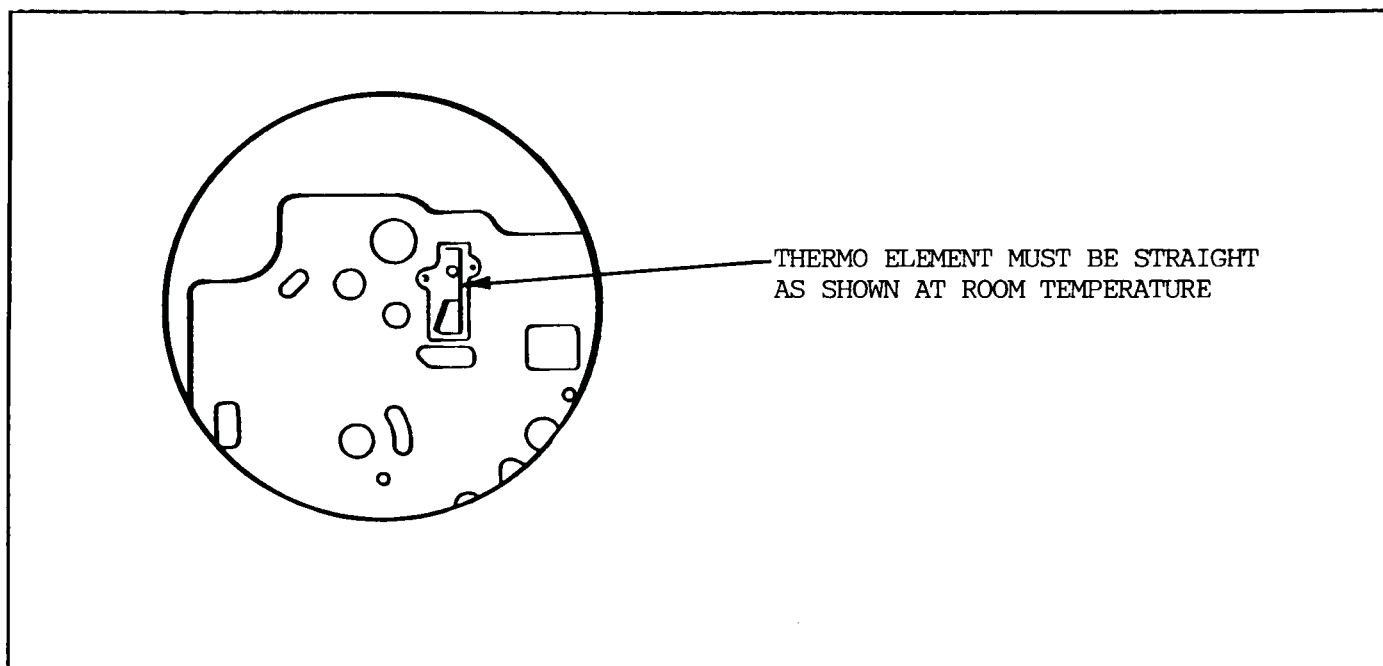

Figure 93

- 22 BRACKET, FUEL PIPE (SOME MODELS)
- 30 GASKET, SPACER PLATE/CHANNEL PLATE
- 31 PLATE, VALVE BODY SPACER
- 32 GASKET, SPACER PLATE/VALVE BODY
- 33 SCREEN ASM., CONV. CLUTCH SOLENOID
- 35 VALVE ASSEMBLY, CONTROL
- 40 BOLT, V.B. TO C.P. (TORQUE HD.) (6)
- 41 BOLT, V.B. TO C.P. (HEX) (1)
- 42 BOLT, V.B. TO DRIVEN SUPPORT (TORQ.) (2)
- 43 BOLT, VALVE BODY TO CASE (HEX) (3)
- 44 PUMP ASSEMBLY
- 45 BOLT, PUMP BODY TO CASE (HEX) (2)
- 46 BOLT, PUMP COVER TO C.P. (HEX) (10)
- 47 BOLT, PUMP COVER TO V.B. (HEX) (1)
- 48 HARNESS, WIRING
- 49 LINK, THROTTLE LEVER TO CABLE
- 50 LEVER & BRACKET ASM., THROTTLE
- 51 PAN, CASE SIDE COVER
- 52 SCREW, SPECIAL M8X1.25X16.0
- 53 NUT, FLANGED HEX (M6X1.0)
- 54 BOLT, M6X1.0X35 LG. P.B./C.P. (HEX) (1)
- 55 BOLT, M6X1.0X45 LG. V.B./C.P. (2)

- 56 WASHER, CONICAL
- 61 WIRE CONDUIT
- 62 CLIP, TWO WIRE
- 64 GASKET, SIDE COVER TO CASE
- 65 GASKET, SIDE COVER TO CHANNEL PLATE
- 67 CLIP, WIRE CONDUIT
- 68 "O" RING, C-C SOLENOID SCREEN (NOT USED ON EARLY MODELS)
- 72 PLATE, CLAMPING
- 132 BOLT, SERVO PIPE RETAINER (TORX.)
- 133 BRACKET, SERVO PIPE RETAINER
- 689 WIER, OIL

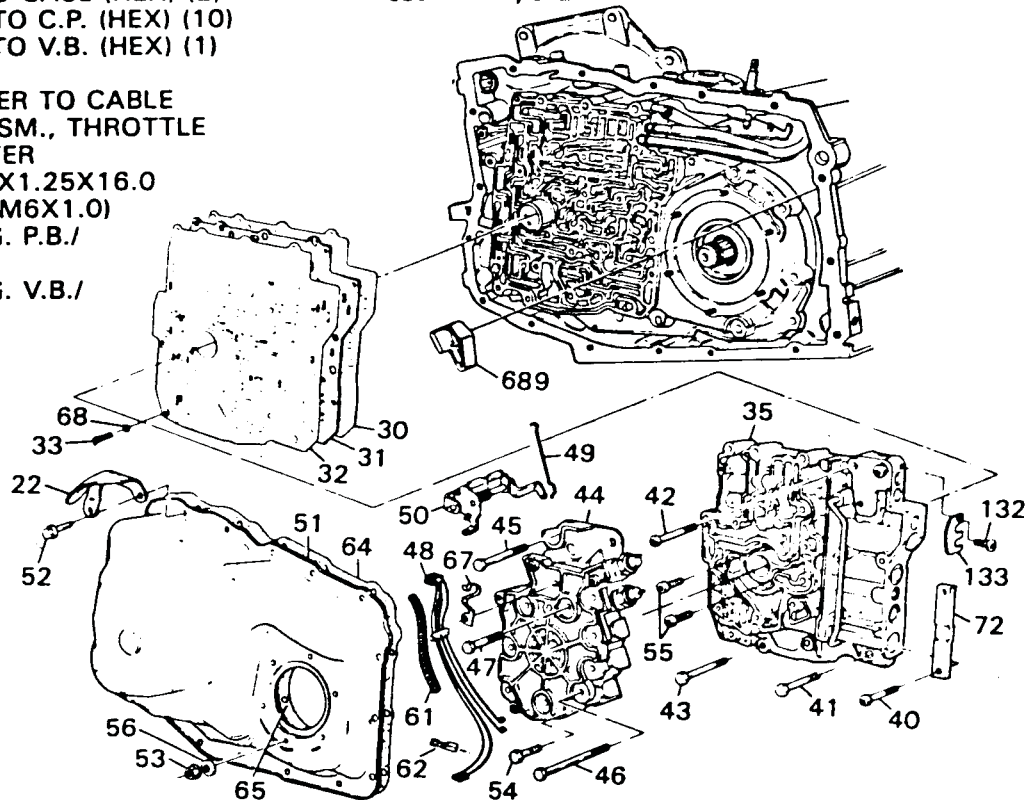
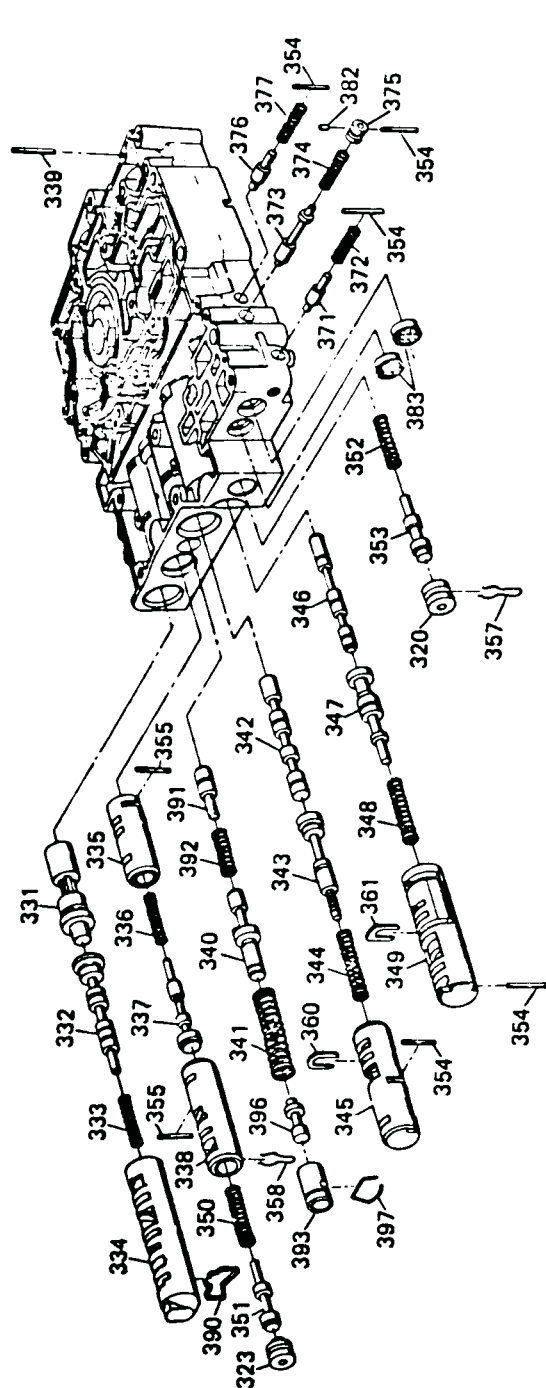

Figure 94



ILL. NO.	DESCRIPTION
320	PLUG, VALVE BORE
323	PLUG, VALVE BORE
331	VALVE, 1-2 SHIFT
332	VALVE, 1-2 THROTTLE VALVE
333	SPRING, 1-2 THROTTLE VALVE
334	BUSHING, 1-2 THROTTLE VALVE
335	BUSHING, 2-3 ACCUMULATOR
336	SPRING, 2-3 ACCUMULATOR
337	VALVE, 2-3 ACCUMULATOR
338	BUSHING, 3-4 M.T.V.
339	PIN, SPRING
340	VALVE, 3-2 CONTROL
341	SPRING, 3-2 CONTROL
342	VALVE, 2-3 SHIFT
343	VALVE, 2-3 THROTTLE VALVE
344	SPRING, 2-3 THROTTLE VALVE
345	BUSHING, 2-3 THROTTLE VALVE
346	VALVE, 3-4 SHIFT
347	VALVE, 3-4 THROTTLE VALVE
348	SPRING, 3-4 THROTTLE VALVE
349	BUSHING, 3-4 THROTTLE VALVE
350	SPRING, 3-4 M.T.V.
351	VALVE, 3-4 M.T.V.
352	SPRING, 4-3 M.T.V.
353	VALVE, 4-3 M.T.V.
354	PIN, SPRING
355	PIN, SPRING
357	RETAINER, SPRING CLIP
358	RETAINER, SPRING
360	RETAINER, THROTTLE VALVE
361	RETAINER, 3-4 T.V.
363	CONTROL BODY
371	VALVE, REVERSE SERVO BOOST
372	SPRING, REVERSE SERVO BOOST
373	VALVE, 1-2 SERVO CONTROL
374	SPRING, 1-2 SERVO CONTROL
375	PLUG, BORE (1-2 SERVO CONTROL)
376	VALVE, 1-2 SERVO BOOST
377	SPRING, 1-2 SERVO BOOST
382	PLUG, CUP
383	SEAL ASSEMBLY, 1-2 SERVO PIPE
390	RETAINER, 1-2 T.V. BUSHING
391	VALVE, 3-2 ISOLATOR
392	SPRING, 3-2 ISOLATOR
393	BUSHING, 3-2 T.V. BIAS
396	VALVE, 3-2 T.V. BIAS
397	RETAINER, 3-2 T.V. BIAS

Figure 95

AUTOMATIC TRANSMISSION SERVICE GROUP

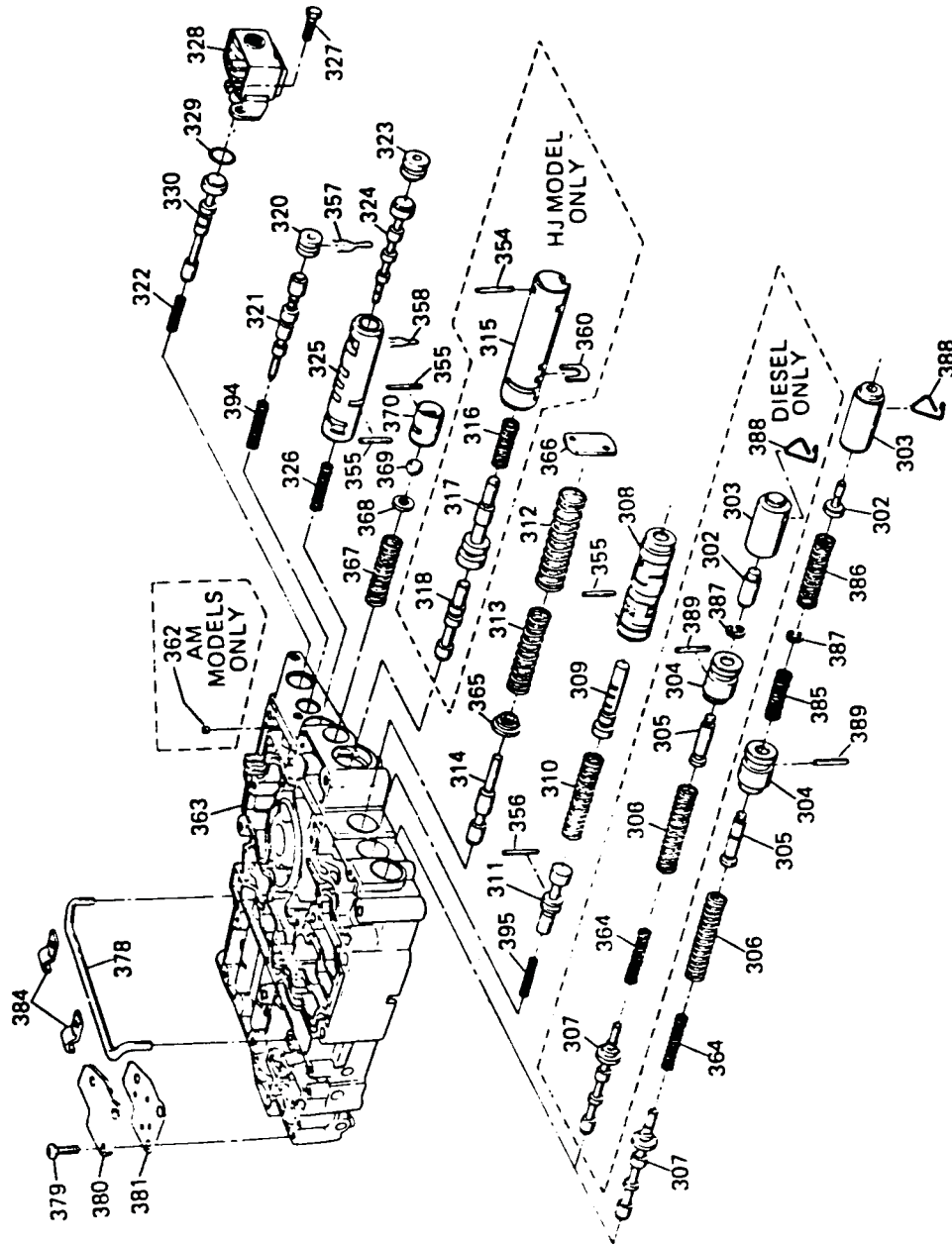

Figure 96

AUTOMATIC TRANSMISSION SERVICE GROUP



ILL. NO.	DESCRIPTION	DESCRIPTION
302	VALVE, LINE BOOST	
303	BUSHING, LINE BOOST VALVE	
304	BUSHING, REVERSE BOOST	
305	VALVE, REVERSE BOOST	
306	SPRING, PRESSURE REGULATOR	
307	VALVE, PRESSURE REGULATOR	
308	BUSHING, THROTTLE VALVE PLUNGER	
309	PLUNGER, THROTTLE VALVE	
310	SPRING, THROTTLE VALVE	
311	VALVE, THROTTLE	
312	SPRING, T.V. FEED (OUTER)	
313	SPRING, T.V. FEED (INNER)	
314	VALVE, T.V. FEED	
315	BUSHING, CONVERTER CLUTCH THROTTLE VALVE (NON C3)	
316	SPRING, CONVERTER CLUTCH THROTTLE VALVE (NON C3)	
317	VALVE, CONVERTER CLUTCH THROTTLE (NON C3)	
318	VALVE, CONVERTER CLUTCH SHIFT (NON C3)	
320	PLUG, VALVE BORE	
321	VALVE, CONVERTER CLUTCH REGULATOR	
322	SPRING, CONVERTER CLUTCH VALVE	
323	PLUG, VALVE BORE	
324	VALVE, 1-2 ACCUMULATOR	
325	BUSHING, 1-2 ACCUMULATOR	
326	SPRING, ACCUMULATOR VALVE	
327	BOLT, M6X1.0X16.0 (SOLENOID)	
328	SOLENOID	
329	SEAL, "O" RING (CONV. CLUTCH SOLENOID)	
330	VALVE, CONVERTER CLUTCH	
354		PIN, COILED SPRING
355		PIN, SPRING
356		PIN, SPRING
357		RETAINER, SPRING CLIP
358		RETAINER, SPRING
360		RETAINER, THROTTLE VALVE
362		PLUG, CUP (ORIFICED)
363		CONTROL BODY
364		SPRING, LO CONTROL
365		SEAT, SPRING (T.V. FEED)
366		PLATE, VALVE STOP (T.V. FEED)
367		SPRING, PUMP PRESSURE RELIEF
368		SEAT, SPRING (PRESSURE RELIEF)
369		BALL, PUMP PRESSURE RELIEF
370		BUSHING, PUMP PRESSURE RELIEF
378		PIPE, 2ND CLUTCH (TO 1-2 SERVO CONTROL VALVE)
379		BOLT, M6X1.0X16.0 (PLATE/VALVE BODY)
380		PLATE, 1-2 SERVO RELEASE PLATE
381		GASKET, RELEASE COVER PLATE
384		RETAINER, 2ND CLUTCH PIPE
385		SPRING, REVERSE BOOST (GAS ONLY)
386		SPRING, PRESSURE REGULATOR MOD. BOOST (GAS ONLY)
387		RETAINER, PRESSURE REGULATOR
388		RETAINER, LINE BOOST VALVE & BUSHING
389		PIN, STRAIGHT (REVERSE BOOST BUSHING)
394		SPRING, CONV. CLUTCH REGULATOR VALVE
395		SPRING, THROTTLE VALVE ASSIST

Figure 97

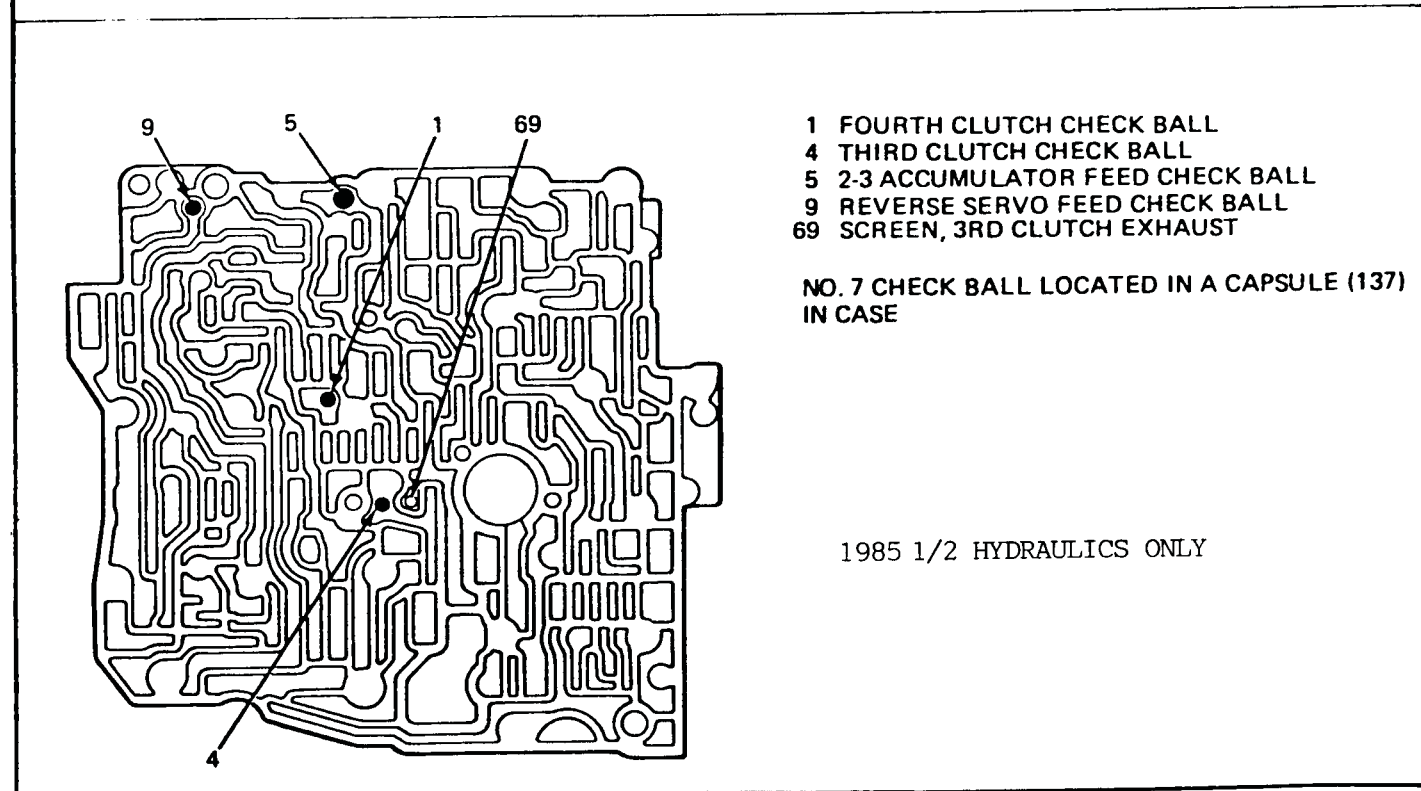
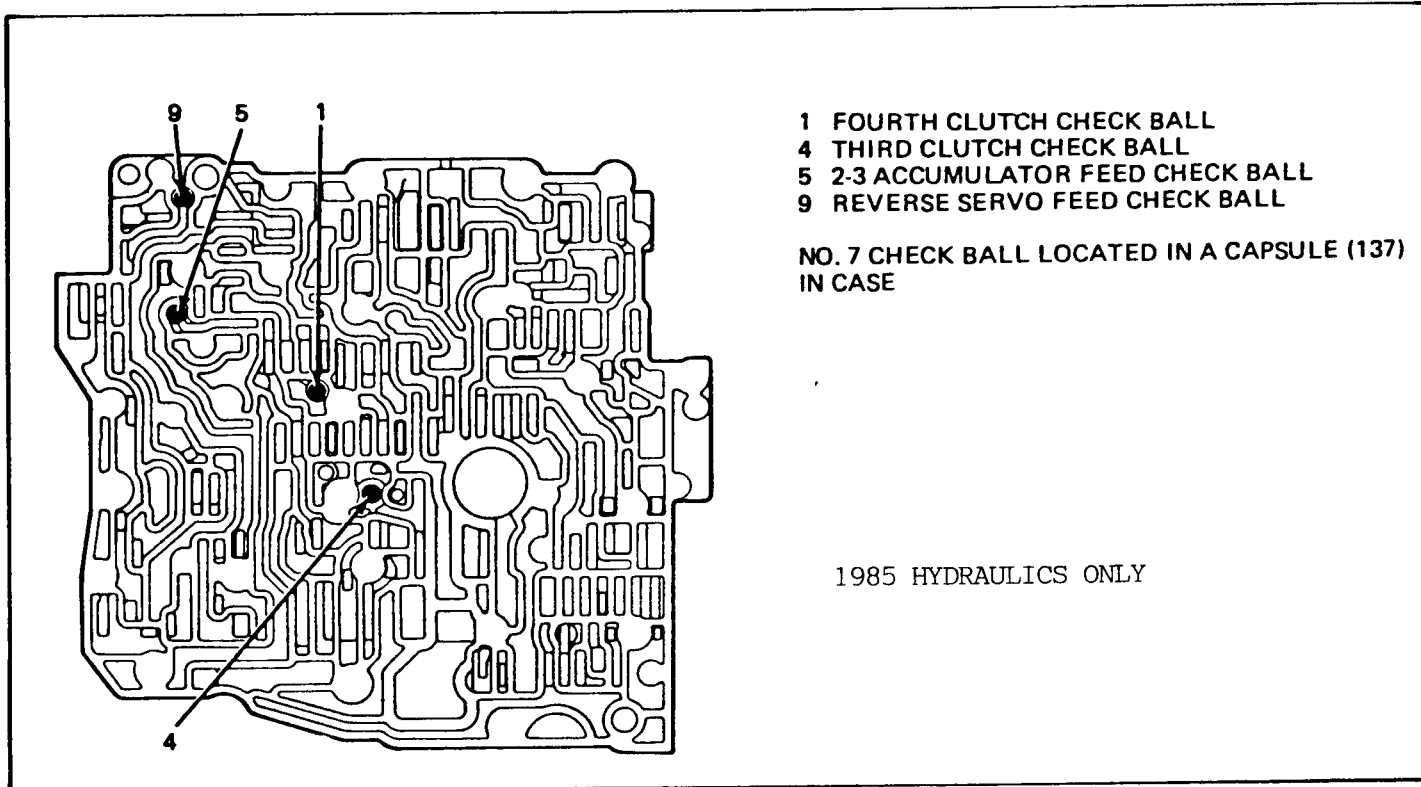
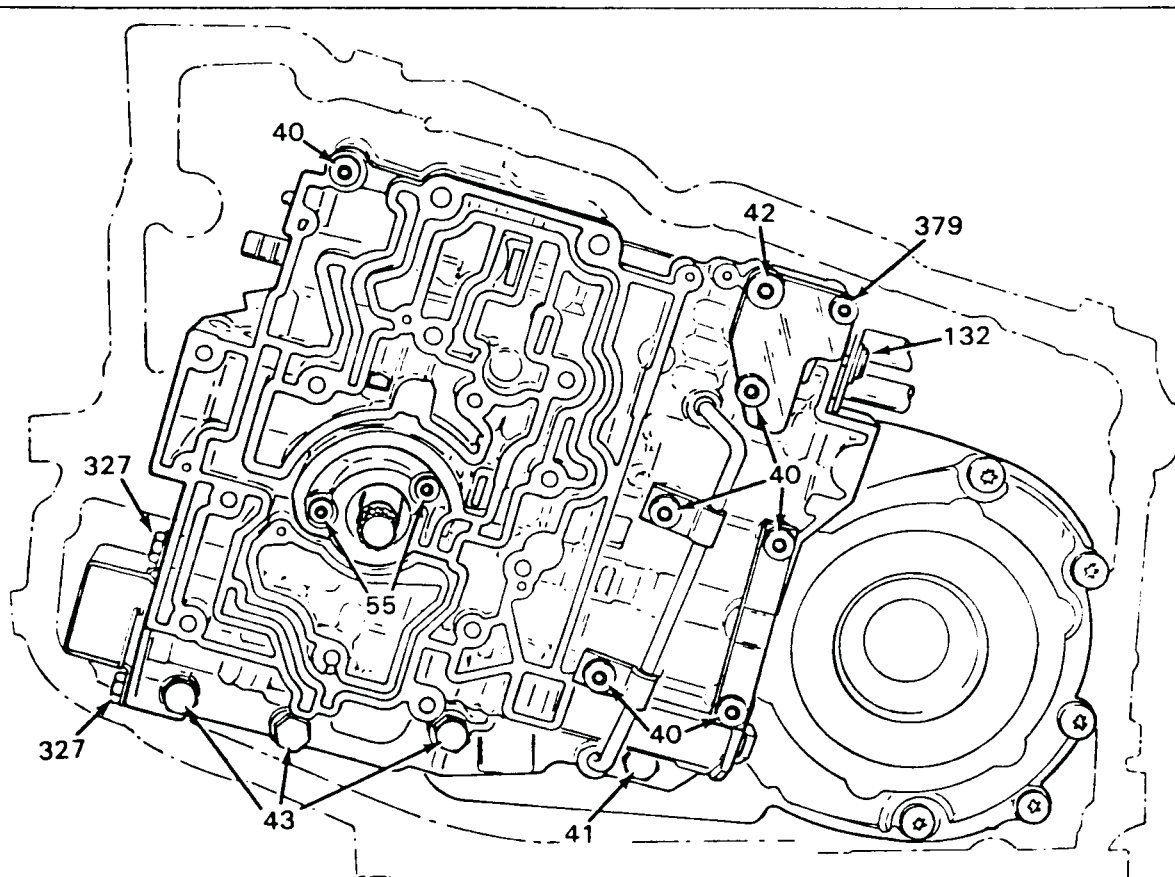

Figure 98

AUTOMATIC TRANSMISSION SERVICE GROUP



- 40 M6 X 1.0 X 60 LG. (6) SIX LOBED SKT. HD. SCREW – 8.0 - 14.0 N·m (6 - 10 FT.-LBS.)
 41 M6 X 1.0 X 35 LG. (1) HEX HD. BOLT – 8.0 - 14.0 N·m (6 - 10 FT.-LBS.)
 42 M8 X 1.25 X 90 LG. (2) SIX LOBED SKT. HD. SCREW – 20.0 - 27.0 N·m (15 - 20 FT.-LBS.)
 43 M8 X 1.25 X 70 LG. (3) HEX HD. BOLT – 20.0 - 27.0 N·m (15 - 20 FT.-LBS.)
 55 M6 X 1.0 X 45 LG. (2) SIX LOBED SKT. HD. SCREW – 8.0 - 14.0 N·m (6 - 10 FT.-LBS.)
 132 M6 X 1.0 X 22 LG. (1) SIX LOBED SKT. HD. SCREW – 8.0 - 14.0 N·m (6 - 10 FT.-LBS.)
 327 M6 X 1.0 X 14 LG. (2) HEX HD. BOLT – 8.0 - 14.0 N·m (6 - 10 FT.-LBS.)
 379 M6 X 1.0 X 16 LG. (1) SIX LOBED SKT. HD. SCREW – 8.0 - 14.0 N·m (6 - 10 FT.-LBS.)

Figure 99

OIL PUMP ASSEMBLY

1. Clean all pump components in clean solvent and dry with compressed air.
2. Inspect the following;
 - * Pump body for pump pocket damage and machined face for damage.
 - * Slide and springs for damage, discard all plastic and rubber parts.
 - * Rotor and vanes for damage.
 - * Vane rings for damage.
 - * Cover and sleeve for damage.
 - * Air check all switches for leakage and terminals for damage
 - * Thermister for damage. (Cadillac Only).

MEASURE COMPONENTS

1. If replacement of the rotor becomes necessary, measure an undamaged section as shown in Figure 101.
2. If replacement of the vanes becomes necessary, measure an undamaged section as shown in Figure 101.
3. If replacement of the slide becomes necessary, measure an undamaged section as shown in Figure 101.
4. Select the proper replacement size using the chart in Figure 101. See the ATSG "Update Handbook".

NOTE: If the correct selective parts are not used, damage to the transaxle will be the result.

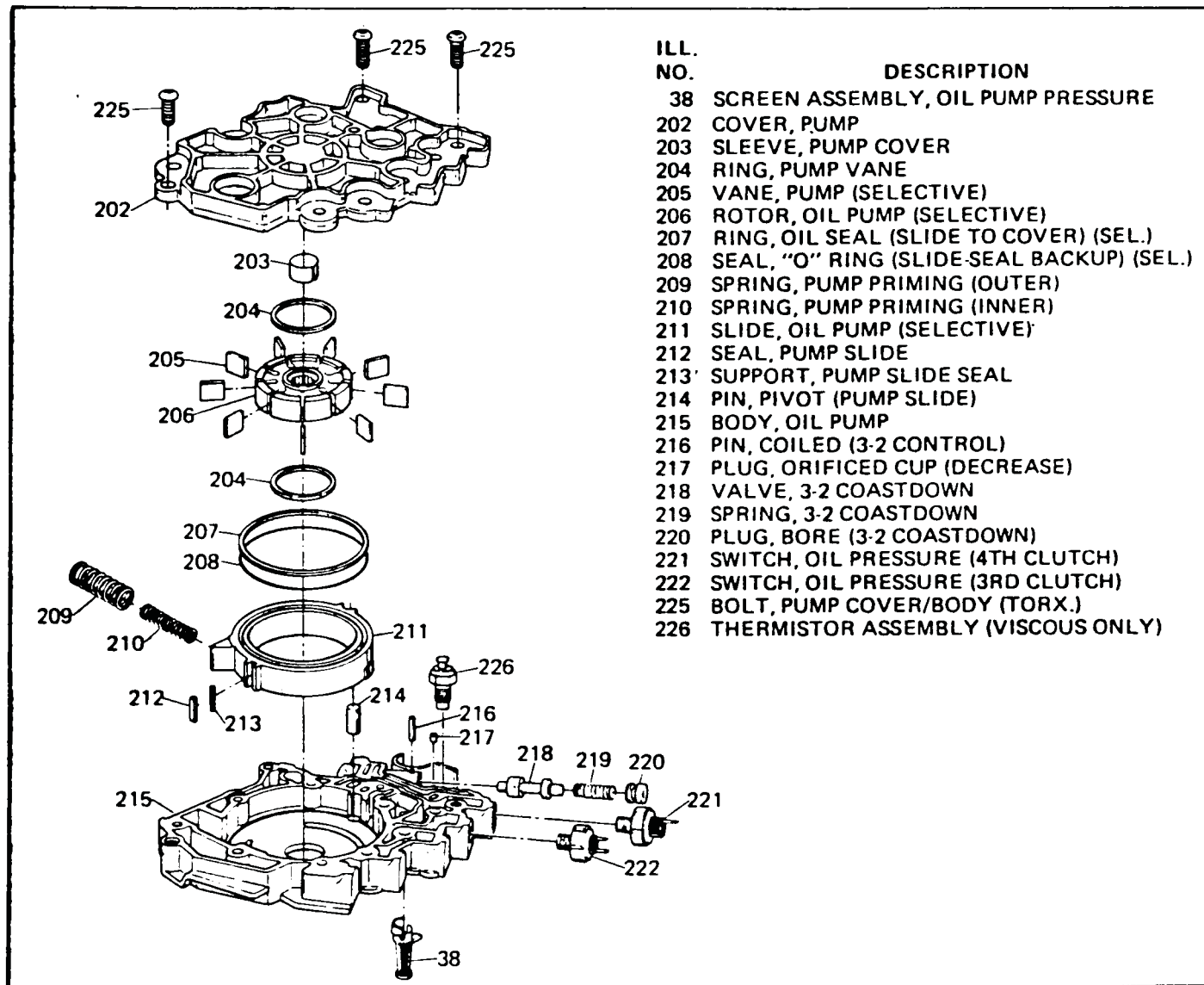
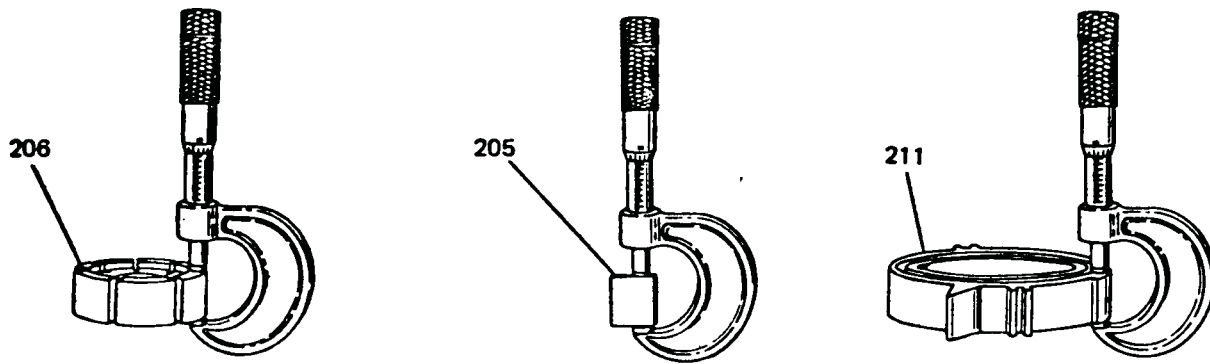

Figure 100

ASSEMBLE OIL PUMP

1. Install 3-2 coastdown valve train into pump body.
2. Insure that decrease orifice (217) and switches are tight in pump body.
3. Install pivot pin and pump slide into pump body.
4. Pull slide towards pivot pin and install slide seal and back-up seal.
5. Install vane ring into pump pocket.
6. Press in slide springs.
7. Install rotor into pump pocket.
8. Install 9 vanes into rotor, insuring that vanes are flush with the top of the rotor.
9. Install vane ring onto rotor inside of vanes.
10. Install pump cover onto pump body and install three pump cover bolts.
11. Push pump pressure screen into pump body. Screen has a tab for location.
12. Install complete oil pump assembly onto the valve body.
13. Install all attaching bolts and torque per specifications (See Figure 102).
14. Insure that oil pump drive shaft will still turn freely after torquing.
15. See wiring diagrams on pages 14 thru 20 for proper wire connections for the particular model you are working on.



205 VANE, OIL PUMP
 206 ROTOR, OIL PUMP
 211 SLIDE, OIL PUMP

ROTOR SELECTION

VANE SELECTION

SLIDE SELECTION

THICKNESS (mm)	THICKNESS (in.)	THICKNESS (mm)	THICKNESS (in.)	THICKNESS (mm)	THICKNESS (in.)
17.593 - 17.963	.7068 - .7072	17.943 - 17.961	.7064 - .7071	17.983 - 17.993	.7080 - .7084
17.963 - 17.973	.7072 - .7076	17.961 - 17.979	.7071 - .7078	17.993 - 18.003	.7084 - .7088
17.973 - 17.983	.7076 - .7080	17.979 - 17.997	.7078 - .7085	18.003 - 18.013	.7088 - .7092
17.983 - 17.993	.7080 - .7084			18.013 - 18.023	.7092 - .7096
17.993 - 18.003	.7084 - .7088				

Figure 101

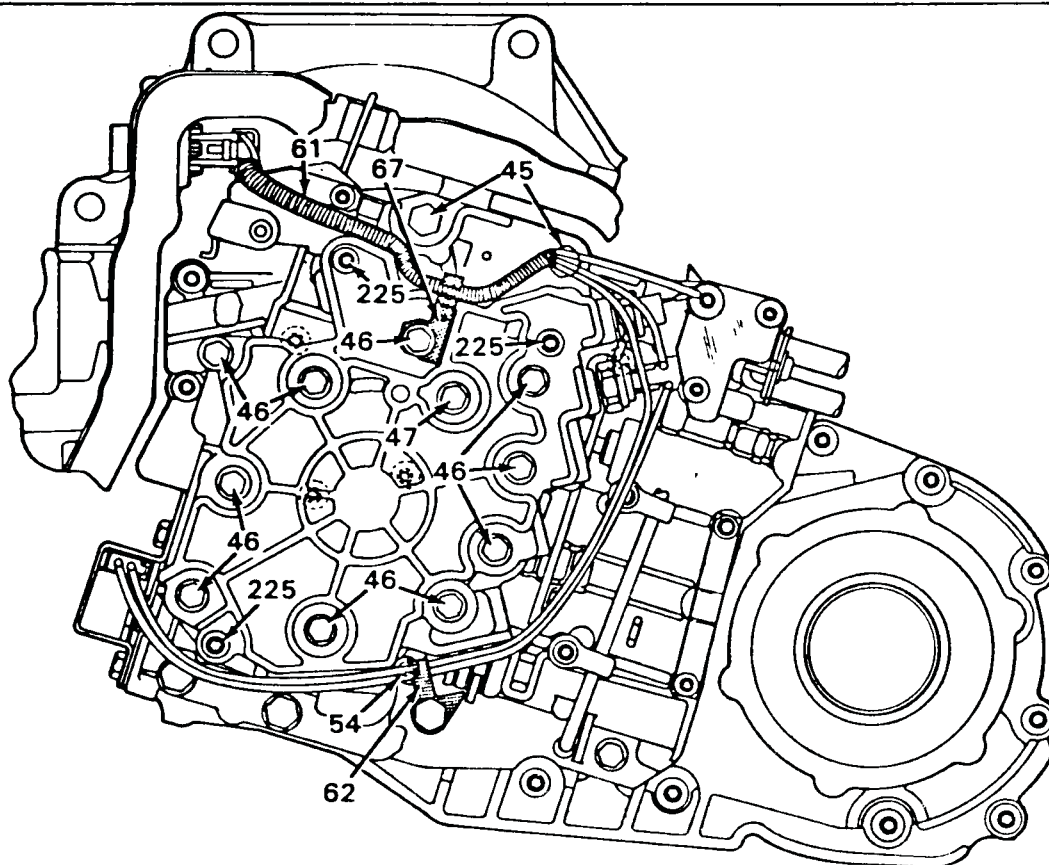

- 45 M8 X 1.25 X 95 LG. (2) HEX HD. BOLT — 20.0 - 27.0 N·m (15 - 20 FT.-LBS.)
 46 M6 X 1.0 X 85 LG. (10) HEX HEAD BOLT — 8.0 - 14.0 N·m (6 - 10 FT.-LBS.)
 47 M6 X 1.0 X 45 LG. (1) HEX HEAD BOLT — 8.0 - 14.0 N·m (6 - 10 FT.-LBS.)
 54 M6 X 1.0 X 35 LG. (1) SOCKET HEAD BOLT — 8.0 - 14.0 N·m (6 - 10 FT.-LBS.)
 61 CONDUIT, WIRE
 62 CLIP, TWO WIRE
 67 CLIP, WIRE CONDUIT
 225 M8 X 1.25 X 20 LG. (3) SIX LOBED SOCKET HEAD SCREW — 20.0 - 27.0 N·m (15 - 20 FT.-LBS.)

Figure 102

INSTALL SIDE COVER

1. Insure that the oil weir is in place on the channel plate (See Figure 45).
2. Insure that wiring harness is properly connected to all switches.
3. Insure that there are no bolts loose.
4. Install "Doughnut" gasket on the channel plate.
5. Install side cover gasket on the case.
6. Install side cover on transaxle.
7. Install six conical washers on the side cover "Doughnut" gasket area. The concave side must be placed towards the cover.
8. Torque the nuts to 7 ft. lb. and the side cover bolts to 10 ft. lbs.

1-2, 3-4 ACCUMULATORS AND GOVERNOR ADAPTER

1. Using compressed air, verify that all pipes running from the accumulator cover are open.
2. DO NOT dis-assemble the pipes from the accumulator cover unless absolutely necessary, as they MUST be resealed with hardening Loc-tite.

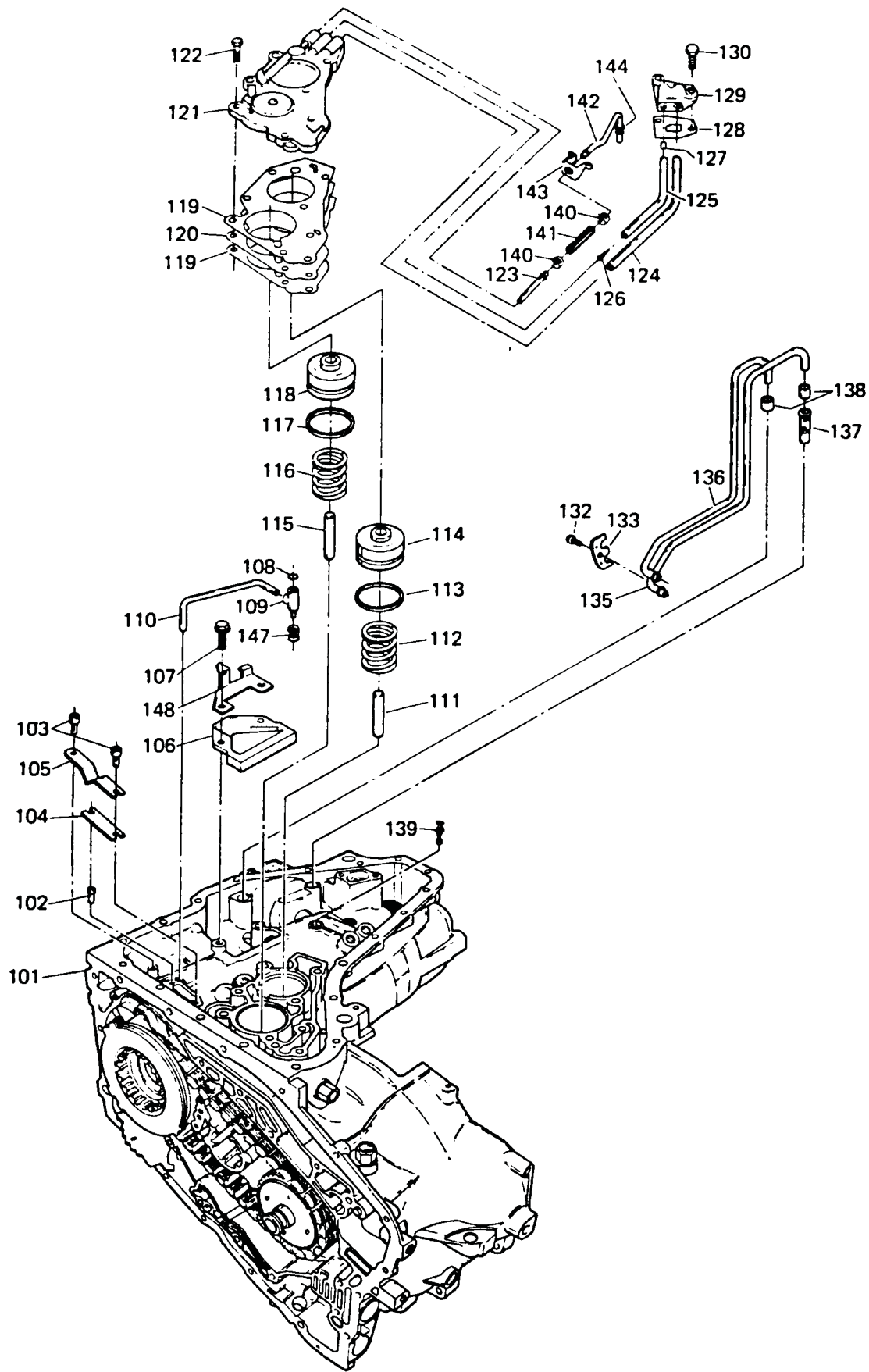

Figure 103

ILL. NO.	DESCRIPTION
101	CASE ASSEMBLY, TRANSMISSION
102	PIN, THERMO ELEMENT
103	PIN & WASHER ASM., THERMO ELEMENT (2)
104	PLATE ELEMENT
105	THERMO ELEMENT
106	OIL SCOOP, SCAVANGER BOTTOM PAN
107	BOLT, (OIL SCOOP/CASE) (HEX) (2)
108	SEAL, SQ. CUT (LUBE OIL PIPE RET./CASE)
109	RETAINER, LUBE OIL PIPE
110	PIPE, LUBE OIL (RETAINER TO DRIVE SPROCKET SUPPORT)
111	PIN, ACCUMULATOR
112	SPRING, 3-4 ACCUMULATOR
113	RING, OIL SEAL ACCUM. PISTON (3-4)
114	PISTON, ACCUMULATOR (3-4)
115	PIN, ACCUMULATOR
116	SPRING, 1-2 ACCUMULATOR
117	RING, OIL SEAL ACCUM. PISTON (1-2)
118	PISTON, ACCUMULATOR (1-2)
119	GASKET, ACCUMULATOR COVER (2)
120	PLATE, ACCUMULATOR SPACER
121	COVER, ACCUMULATOR
122	BOLT, ACCUMULATOR COVER/CASE (7)
123	PIPE, LUBE OIL (ACCUMULATOR COVER/ F.D. INTERNAL GEAR)
124	PIPE, GOVERNOR RETURN
125	PIPE, GOVERNOR FEED
126	SCREEN ASSEMBLY, GOVERNOR
127	PLUG, ORIFICED CUP (GOVERNOR OIL PIPES RETAINER)
128	GASKET, GOV. OIL PIPE RETAINER
129	RETAINER, GOVERNOR OIL PIPE
130	BOLT, GOVERNOR PIPE RET. (HEX) (2)
132	BOLT, SERVO PIPE RETAINER (TORX.)
133	BRACKET, SERVO PIPE RETAINER
135	PIPE, 1-2 SERVO (REL. OIL)
136	PIPE, 1-2 SERVO APPLY
137	CAPSULE ASSEMBLY, BALL CHECK
138	SEAL ASSEMBLY, 1-2 SERVO PIPE
139	STOP, 1-2 BAND ASSEMBLY
140	CLAMP, HOSE
141	HOSE, LUBE OIL
142	PIPE, LUBE OIL
143	RETAINER, F.D. PIPE LUBE OIL
144	WASHER, F.D. PIPE LUBE OIL RETAINER
147	SPRING, LUBE OIL PIPE RETAINER
148	BRACKET, 1-2 SERVO PIPES RETAINER

Figure 103 Legend

Figure 104

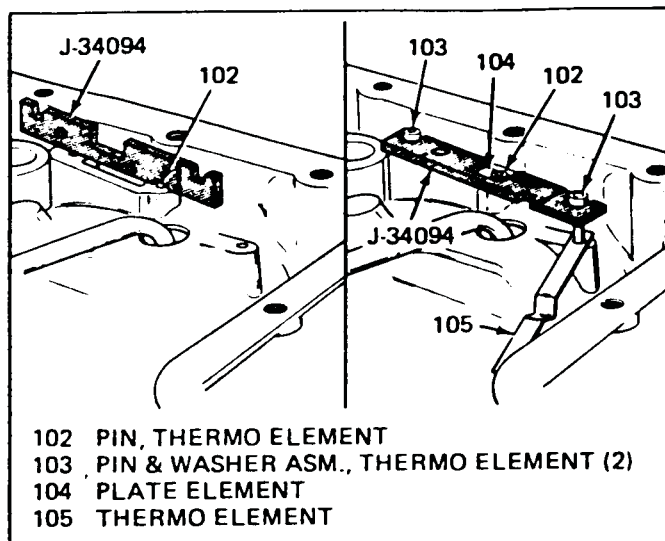

Figure 105

THERMO ELEMENT REPLACEMENT PROCEDURE

1. Set thermo pin (102) height with tool J-34094 as shown in Figure 105.
2. Install the element plate (104).
3. Install thermo element pin and washer assemblies, with thermo element placed on right pin as shown in Figure 105.
4. Set height of pins with height gage J-34094 as shown in Figure 105.
5. Connect thermo element to remaining pin with thermo element resting on top of the element plate.

ASSEMBLE BOTTOM PAN AND ASSOCIATED PARTS

1. Install accumulator springs into case. The 3-4 spring is larger than 1-2 spring.
2. Install new seals on both accumulator pistons and lubricate with petrolatum.
3. Install pistons into the case using the accumulator pins as a tool, or lever, to gently roll the pistons in place. Then push the pins all the way down.
4. Install front lube pipe into plastic retainer, seal on retainer, and spring in case pocket.
5. Install complete assembly into case by tapping lube pipe into driven sprocket support with light hammer.
6. Install black plastic oil scavenger, and servo pipe retaining bracket, install bolts and torque to 15 ft. lbs.

7. If governor pipes and final drive lube pipe were removed from accumulator cover, they MUST be re-sealed with cup plug sealant Loc-tite No. 271.
8. Sealant must also be used on pipes at the governor adapter end.
9. Install accumulator cover gasket, spacer plate, and another gasket onto case.
10. Install accumulator cover, pipes, and governor adapter as an assembly, onto the case. Rear lube pipe must be tapped into the final drive ring gear, and the proper retainer installed.
11. Install bolts into accumulator cover, and governor adapter, and torque to 20 ft. lbs.
NOTE: Governor adapter bolts are longer and have a shoulder on them.
12. Install new filter seal into the case with proper installation tool, insure that it is fully seated on case.
13. Lubricate filter neck with petrolatum, and install filter into case.
14. Install pan gasket onto the case.
15. Install magnet into bottom pan, position over dimple in bottom pan.
16. Install bottom pan on case and attaching bolts, and torque to 10 ft. lbs.

ASSEMBLE REVERSE AND 1-2 SERVOS

1. Install new seal on the reverse servo piston. The reverse servo piston seal is a lip design, and when installed the lip MUST face up in the servo bore.
 2. Install return spring on reverse servo piston assembly.
 3. Install reverse servo assembly into the case.
 4. Install new "O" ring on the servo cover.
 5. Install servo cover into case, and use pressure to push in, and then install servo snap ring.
- NOTE: The servo assemblies will not interchange. The reverse servo pin is longer than the 1-2 servo pin.
6. Install new seal on the 1-2 servo piston. The 1-2 servo seal is a scarf-cut design. Use petrolatum to retain the ends of the seal in the groove.
 7. Install return spring on the 1-2 servo piston assembly.

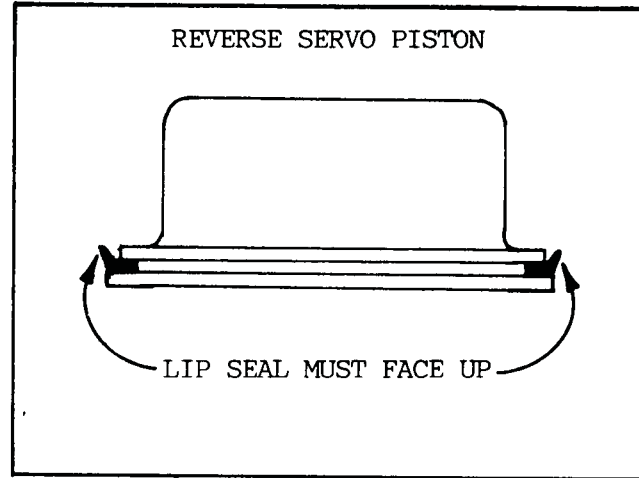

Figure 106

8. Install new "O" ring on servo cover.
9. Install complete 1-2 servo assembly into case, use pressure on cover to push in and install snap ring.
10. Use extra care so as not to cut 1-2 servo seal or "O" ring.

CHECKING SERVO PIN LENGTH

1. Install J-33382 tool as shown in Figure 108. Use the reverse servo pin for checking the reverse servo, and the 1-2 pin for checking the 1-2 servo. They are different lengths.
2. Apply 20 ft. lbs. torque to the tool as shown in Figure 108.
3. Check the pin length with the tool.
*If the "GO" side will not slide under the head, the pin is too short.
*If the "NO-GO" side will slide under the head, the pin is too long.
*If the "GO" side will slide under the head, and the "NO-GO" side will not, the pin length is correct.
4. Correct the pin length as necessary using the chart in Figure 109.

SPECIAL NOTE:

The servo pins will not interchange. The reverse servo pin is longer than the 1-2 servo pin. If the servo pins are installed incorrectly, the vehicle will try to go forward in all ranges.

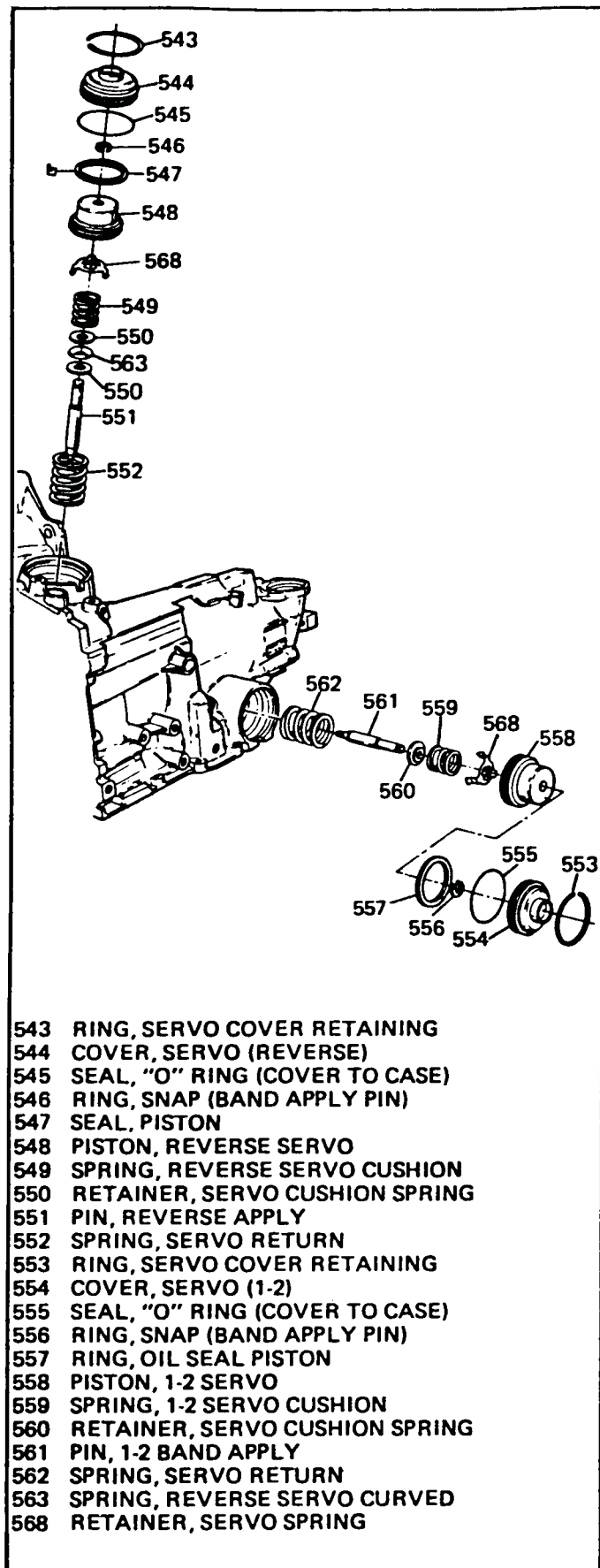

Figure 107

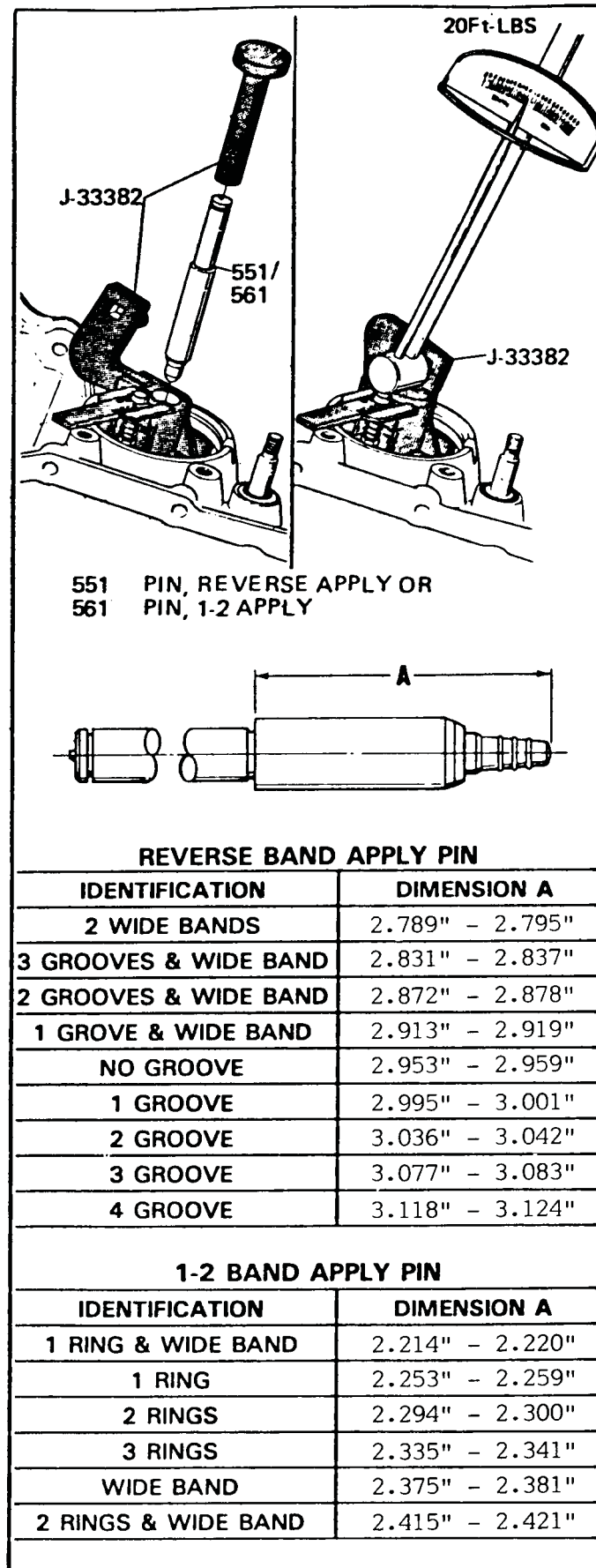

Figure 108

THM 440-T4 SPEED ROTOR TOOTH COUNTS BY MODEL

1988 MODELS

8T = CMH, CWH,
 11T = CFH,
 13T = AFH,
 14T = AAH, ANH, BJH, BKH, BTH, FBH, FJH, FSH,
 15T = CRH, CTH,
 10T SPEEDO GEAR = ABH, ATH, CXH, BRH, BYH, FCH,

1989-90 MODELS

8T = CLH, CPH,
 11T = CDH, CYH,
 13T = AFH, CZH,
 14T = AAH, ABH, ANH, ATH, BAH, BFH, BHH, BJH, BPH, BWH, PAH,
 15T = BDH, BMH,

1991 MODELS

8T = YBH, YCH,
 11T = YAH, YDH, YFH, YHH, YRH,
 13T = YJH,
 14T = KDH, KHH, KLH, WDH, WHH, WJH, WMH, WNH, WPH, BXH, VYH,
 15T = KPH, YSH, YTH, WFH, WKH,

Special Note: The only information available at time of printing.

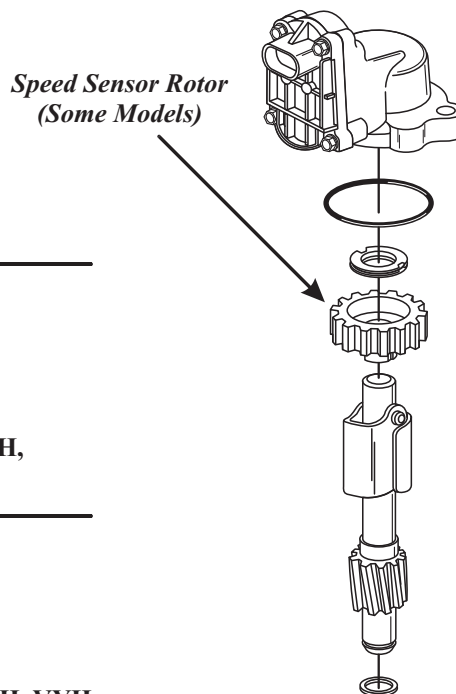
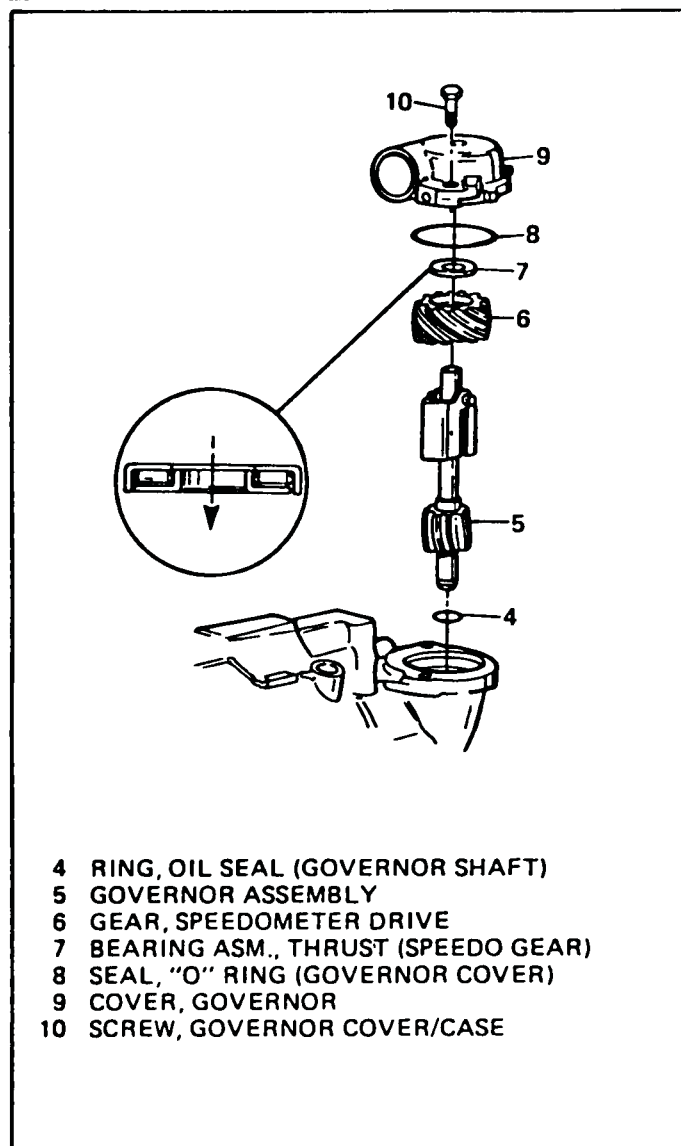

Figure 109



- 4 RING, OIL SEAL (GOVERNOR SHAFT)
- 5 GOVERNOR ASSEMBLY
- 6 GEAR, SPEEDOMETER DRIVE
- 7 BEARING ASM., THRUST (SPEEDO GEAR)
- 8 SEAL, "O" RING (GOVERNOR COVER)
- 9 COVER, GOVERNOR
- 10 SCREW, GOVERNOR COVER/CASE

Figure 110

INSTALL GOVERNOR ASSEMBLY

1. Clean governor assembly thoroughly in clean solvent.
2. Inspect governor for following:
 - * Blocked passage thru shaft.
 - * Damaged springs or binding weights.
 - * Check balls sealing properly.
3. Install new solid seal on shaft.
4. Install governor assembly into case.
5. Install speedometer gear on governor shaft.
6. Install bearing on top of speedometer gear, black side up.
7. Install new "O" ring seal on governor cover and retain with petrolatum.
8. Install governor cover onto case, and insure that cover pilots on shaft.
9. Install bolts, torque to 10 ft. lbs.

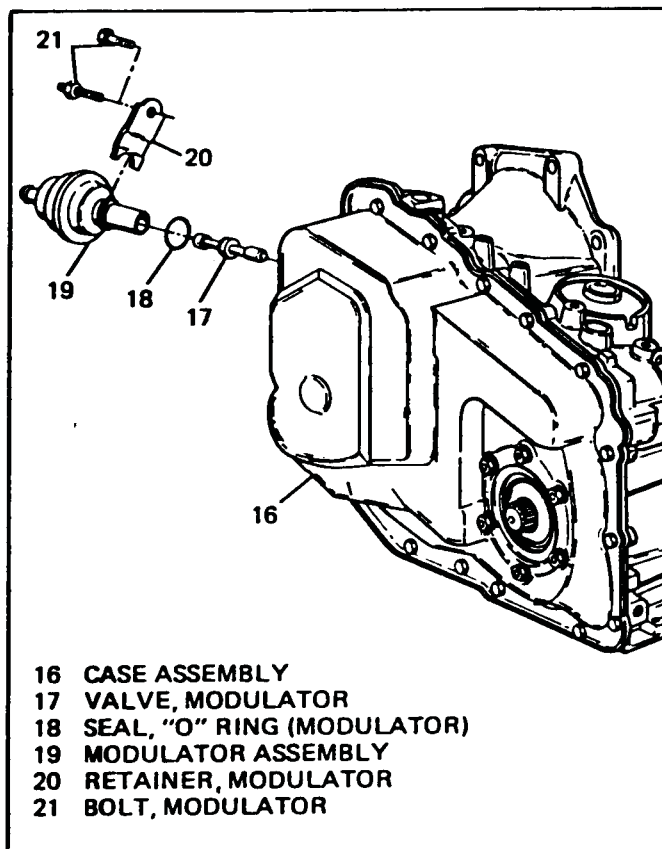

- 16 CASE ASSEMBLY
- 17 VALVE, MODULATOR
- 18 SEAL, "O" RING (MODULATOR)
- 19 MODULATOR ASSEMBLY
- 20 RETAINER, MODULATOR
- 21 BOLT, MODULATOR

Figure 111

INSTALL MODULATOR AND MODULATOR VALVE

1. There are currently two different types of modulators, and modulator valves, as shown in Figures 112 and 113. Be certain that you have compatible parts together.
2. Install modulator valve into case.
3. Install new "O" ring on modulator.
4. Install compatible modulator in case.
5. Install modulator retainer and bolt.
6. Torque modulator bolt to 20 ft. lbs.

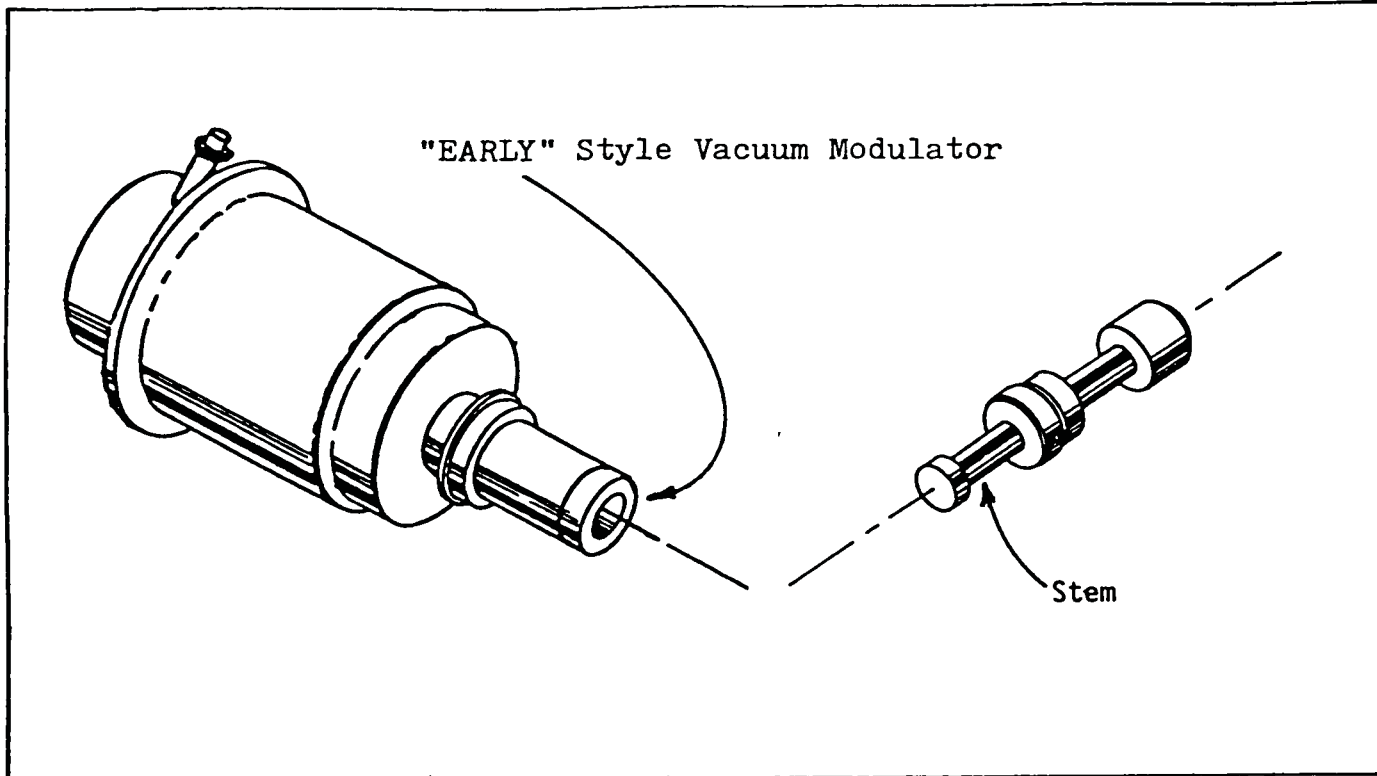

Figure 112

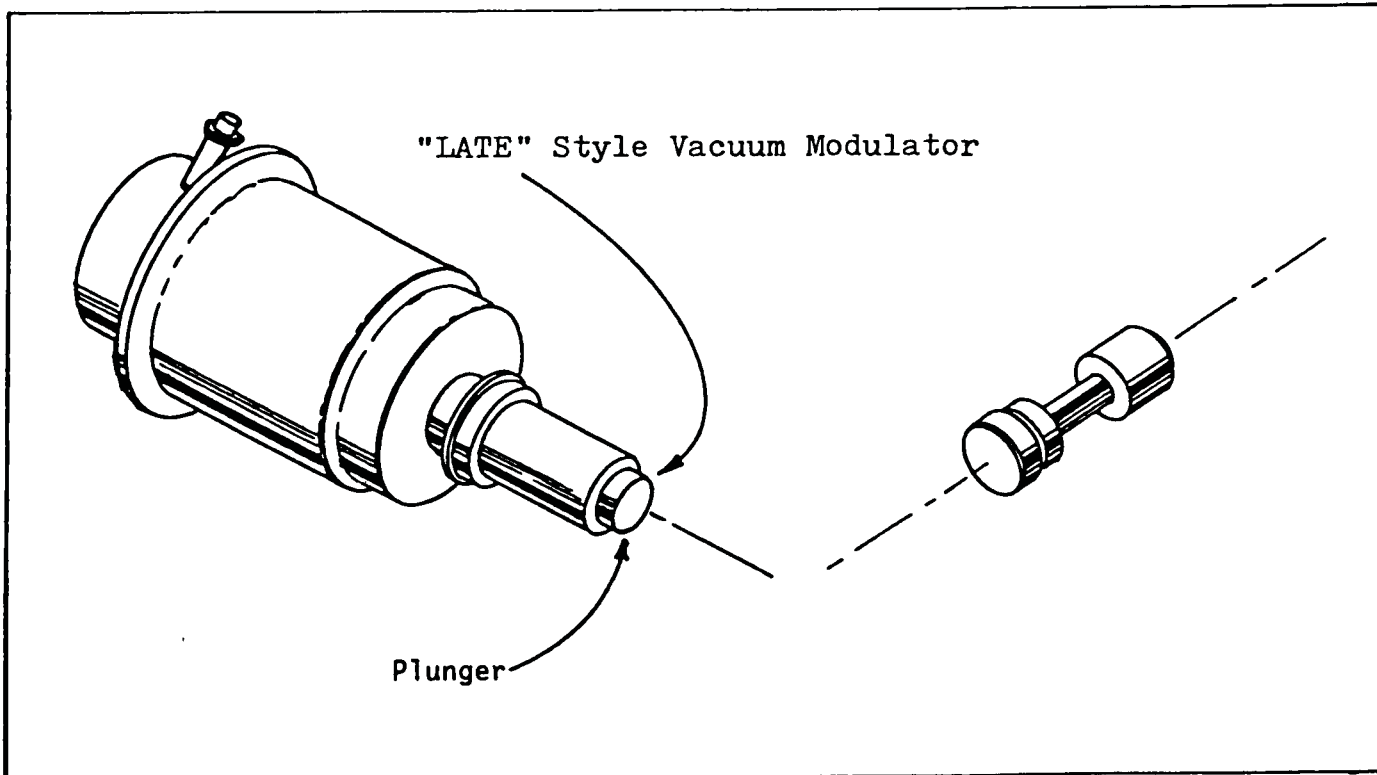

Figure 113



Technical Service Information

ProCarManuals.com

PART NO.	DESCRIPTION OF USAGE	THREAD SIZE	ASM. TORQUE
56	CONNECTOR COOLER FITTING	1/4-18 SPL	41.0 N·m (30 lb.-ft.)
21	MODULATOR TO CASE	M8 X 1.25 X 20.0	27.0 N·m (20 lb.-ft.)
225	PUMP COVER TO PUMP BODY (TORX HD.)	M8 X 1.25 X 20.0	27.0 N·m (20 lb.-ft.)
132	SERVO PIPE BRACKET TO VALVE BODY (TORX HD.)	M6 X 1.0 X 22.0	14.0 N·m (10 lb.-ft.)
529	PIPE PLUG	1/8-27 NPTF	14.0 N·m (10 lb.-ft.)
542	CASE TO DRIVE SPROCKET SUPPORT (TORX HD.)	M8 X 1.25 X 23.5	27.0 N·m (20 lb.-ft.)
10	GOVERNOR TO CASE	M8 X 1.25 X 30.0	27.0 N·m (20 lb.-ft.)
222	PRESSURE SWITCH	1/8-27 PTF, SAE SHORT	14.0 N·m (10 lb.-ft.)
327	SOLENOID TO VALVE BODY	M6 X 1.0 X 16.0	14.0 N·m (10 lb.-ft.)
53	CASE SIDE COVER TO CH. PLT. (NUT)	M6 X 1.0	14.0 N·m (10 lb.-ft.)
47	PUMP COVER TO VALVE BODY	M6 X 1.0 X 45.0	14.0 N·m (10 lb.-ft.)
46	PUMP COVER TO CHANNEL PLATE	M6 X 1.0 X 85.0	14.0 N·m (10 lb.-ft.)
42	VALVE BODY TO CASE (TORX HD.)	M8 X 1.25 X 90.0	27.0 N·m (20 lb.-ft.)
43	VALVE BODY TO CASE	M8 X 1.25 X 70.0	27.0 N·m (20 lb.-ft.)
45	PUMP BODY TO CASE	M8 X 1.25 X 95.0	27.0 N·m (20 lb.-ft.)
41	VALVE BODY TO CHANNEL PLATE	M6 X 1.0 X 35.0	14.0 N·m (10 lb.-ft.)
40	VALVE BODY TO CH. PLATE (TORX. HD.)	M6 X 1.0 X 60.0	14.0 N·m (10 lb.-ft.)
26,27,71	CHANNEL PLATE TO CASE (TORX HD.)	M8 X 1.25 X 30.0	27.0 N·m (20 lb.-ft.)
27,70	CHANNEL PLT. TO DRIVEN SPR. SUPPORT (TORX HD.)	M8 X 1.25 X 45.0	27.0 N·m (20 lb.-ft.)
40,42	CHANNEL PLT. TO DRIVEN SPR. SUPPORT (TORX HD.)	M8 X 1.25 X 45.0	27.0 N·m (20 lb.-ft.)
52	SPECIAL, SIDE COVER TO CASE	M8 X 1.25 X 16.0	13.0 N·m (10 lb.-ft.)
122	ACCUMULATOR COVER TO CASE	M8 X 1.25 X 30.0	27.0 N·m (20 lb.-ft.)
107	OIL SCOOP TO CASE	M8 X 1.25 X 30.0	13.0 N·m (10 lb.-ft.)
130	RETAINER, GOVERNOR OIL PIPE	M8 X 1.25 X 35.0	27.0 N·m (20 lb.-ft.)
60	SPECIAL, TRANS OIL PAN TO CASE	M8 X 1.25 X 16.0	13.0 N·m (10 lb.-ft.)
705	MANUAL SHAFT TO INSIDE DETENT LEVER (NUT)	M10 X 1.5	34.0 N·m (25 lb.-ft.)
706	MANUAL DETENT SPRING TO CHANNEL PLT. (TORX HD.)	M6 X 1.0 X 22.0	14.0 N·m (10 lb.-ft.)
54	PUMP BODY TO VALVE BODY (TORX HD.)	M6 X 1.0 X 30.0	14.0 N·m (10 lb.-ft.)

Figure 114

AUTOMATIC TRANSMISSION SERVICE GROUP

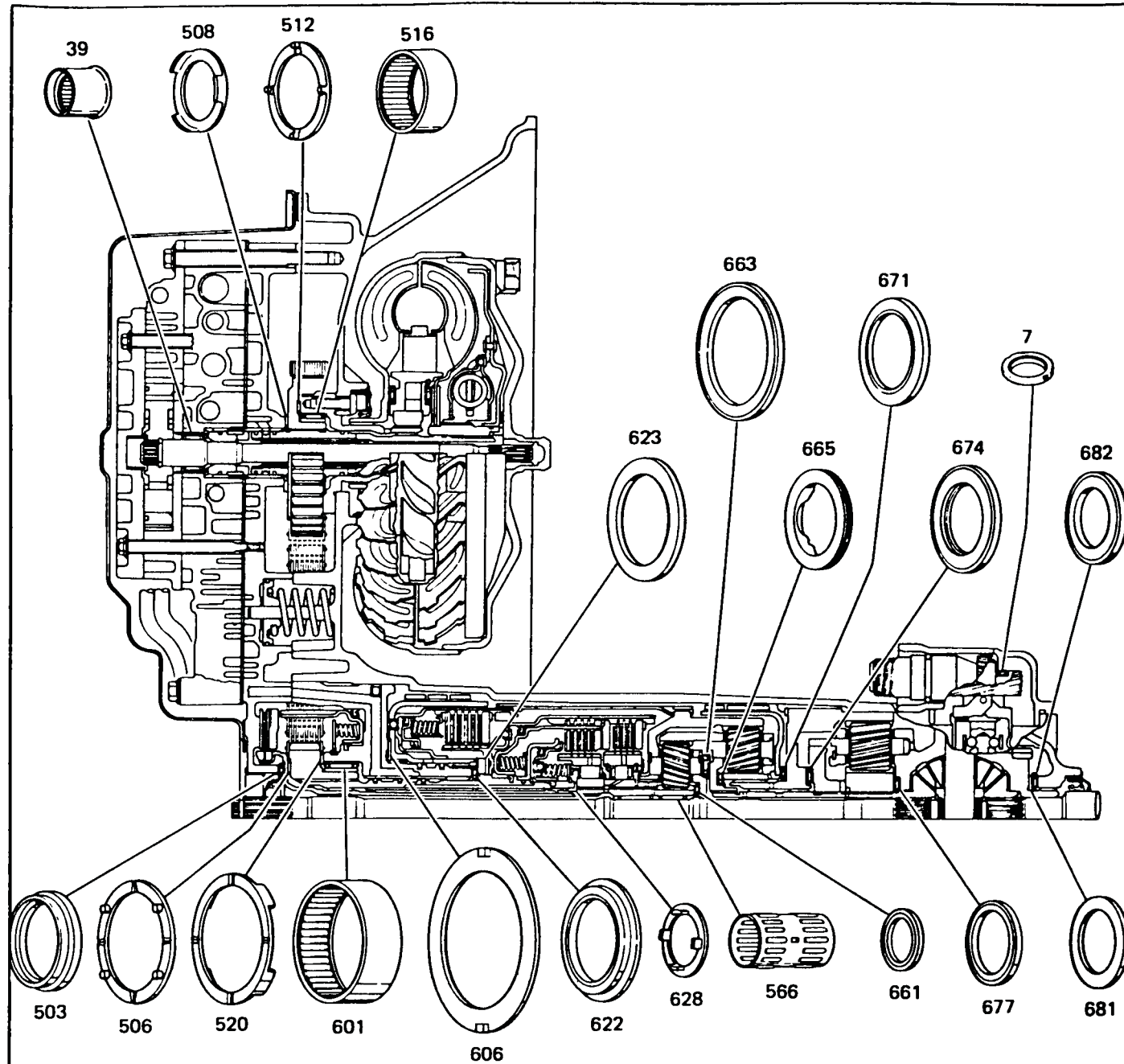

- | | | | |
|-----|---|-----|--|
| 7 | BEARING ASM., THRUST (SPEEDO GEAR) | 622 | BEARING, THRUST (SUPPORT/SELECTIVE THRUST WASHER) |
| 39 | BEARING & SLEEVE ASM., OIL PUMP SHAFT | 623 | WASHER, THRUST (SELECTIVE) |
| 503 | BEARING ASSEMBLY, 4TH CLUTCH HUB/ CHANNEL PLATE | 628 | WASHER, THRUST (INPUT SHAFT/SUN GEAR) |
| 506 | WASHER, THRUST (4TH CLUTCH HUB/ DRIVEN SPROCKET) | 661 | BEARING ASSEMBLY, INPUT SUN/CARRIER |
| 508 | WASHER, THRUST (DRIVE SPROCKET/ CHANNEL PLATE) | 663 | BEARING ASM., INPUT/REACTION CARRIER |
| 512 | WASHER, THRUST (DRIVE SPROCKET/ SPROCKET SUPPORT) | 665 | BEARING ASSEMBLY, REACTION CARRIER/ SUN GEAR |
| 516 | BEARING ASSEMBLY, DRAWN CUP | 671 | BEARING ASSEMBLY, REACTION SUN GEAR/ INTERNAL GEAR |
| 520 | WASHER, THRUST (DRIVEN SPROCKET/ DRIVEN SPROCKET SUPPORT) | 674 | BEARING ASM., INT. GEAR/PARK GEAR |
| 566 | BEARING, INPUT SUN GEAR/OUTPUT SHAFT | 677 | BEARING, THRUST (SUN GEAR/CARRIER) |
| 601 | BEARING ASSEMBLY, DRAWN CUP | 681 | WASHER, CARRIER/CASE SELECTIVE |
| 606 | WASHER, THRUST (SUPPORT/2ND CLUTCH) | 682 | BEARING ASM., SELECTIVE WASHER/CASE |

Figure 115

Transmission Support Fixture Base  E J 3289-20	Handle  E J 7079-2	Handle  E J 8092	Torque Converter Pressurization Kit  A J 21369-D
Forward Clutch Spring Compressor  E J 23327-1	Compressor Screw and Frame  E J 23456		Universal Remover  E J 23907
Dial Indicator Stand and Guide Pin Set  E J 25025-A	#30 Torx Bit or Equivalent  A J 25359-4		#40 Torx Bit or Equivalent  E J 25359-5
Output Shaft Aligning and Loading Tool  E J 26958-16	Adapter Plug  E J 26958-10	Torque Converter End-Play Fixture  E J 29830	
Converter Seal Installer  E J 28540	Transmission Modulator Checking Tool  A J 35258	"C" Ring Remover - Output Shaft  E J 28583	
Transmission Support Fixture  E J 28664-B	Bushing Installer  E J 25019-6	Pump Bearing - Installer and Remover  E J 28698	
Axle Seal Installer  E J 29130	Bushing and Universal Remover Set  E J 26941 A → J 29369		Turbine Shaft Seal Installers and Sizer (1 Seal)  E J 29569 E J 29829
Bearing Installer - Drive Sprocket Support  E J 28677	Clutch Assembly/Final Drive Remover and Installer  E J 33381	1-2 and Reverse Bands Apply Pin Gauge  E J 33382	
Input Shaft End Play Tool  E J 33386	Input Clutch Piston Seal Protector  E J 34091	Third Clutch Piston Seal Protector  E J 34092	
Thermo Element Height Gauge  E J 34094	Output Shaft Loading Tool Adapter  E J 34095	Left Side Axle Seal Installer  E J 34115	
Input Seal Installer  E J 34741	Driven Sprocket Support Bearing Installer  E J 34126	Driven Sprocket Support Bearing Remover  E J 34129	

Figure 116

AUTOMATIC TRANSMISSION SERVICE GROUP



1985¹/₂ AUTOMATIC TRANSAXLE DIAGNOSIS AND UNIT REPAIR ILLUSTRATIONS

Listed below are the model designations for the 1985 and 1985¹/₂ applications.
Refer to the illustration on this page for transaxle identification information.

MODELS

1985		1985 ¹ / ₂	
AY	BN	AF	AM
BS	BU	BR	CN
*CW	HT	BV	HA
BS	*BC	BW	HJ
BX	OB	CM	
OY	CP		

(*USED IN 1984 MODEL YEAR VEHICLES.)

ProCarManuals.com

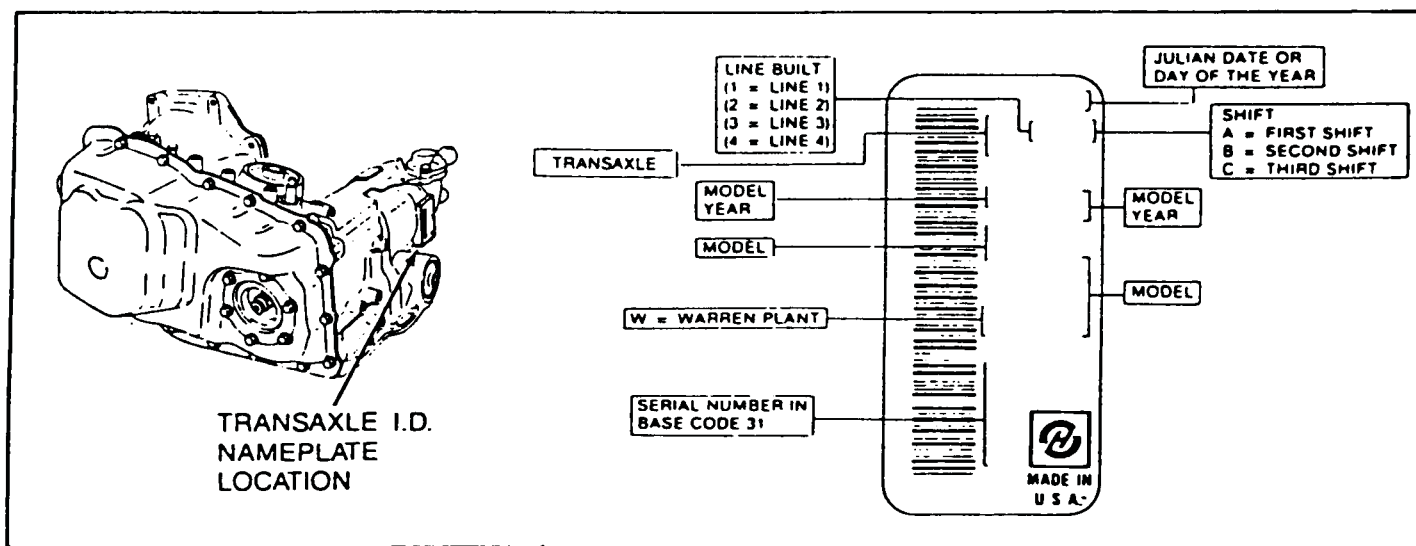

THM 440-T4 TRANSAXLE I.D. INFORMATION

AUTOMATIC TRANSMISSION SERVICE GROUP

PRELIMINARY CHECK PROCEDURE

Check the transaxle fluid to make sure that it is at the proper level. Note the fluid color. Burned fluid loses its red color and has an acid odor.

NOTICE: IF THE OIL IS BURNED AND/OR CLUTCH PLATE MATERIAL IS FOUND IN THE OIL PAN, REQUEST A REPLACEMENT TRANSAXLE.

CHECK AND ADJUST T.V. CABLE
CHECK OUTSIDE MANUAL LINKAGE AND CORRECT
CHECK ENGINE TUNE*
INSTALL OIL PRESSURE GAGE**
CONNECT TACHOMETER TO ENGINE

CHECK OIL PRESSURES IN THE FOLLOWING MANNER:

Minimum Line Pressure Check

With the parking brake and vehicle brakes applied, take the line pressure readings in the ranges and at the engine r.p.m.'s indicated in the chart below.

Full Line Pressure Check

Full line pressure readings are obtained by removing the vacuum line from modulator, and with the parking brake and vehicle brakes applied, take the line pressure readings in the ranges and at the engines r.p.m.'s indicated in the chart below.

NOTICE Total running time not to exceed 2 minutes.

CAUTION Brakes must be applied at all times.

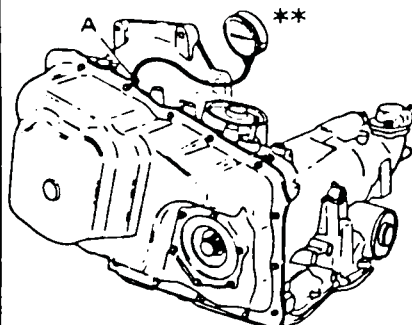

	MODEL	AF, AM, BV, CM, CN, HA, HJ		BR, BW		
		RANGE	kPa	PSI	kPa	PSI
TRANSMISSION LINE PRESSURE	MINIMUM LINE (1250 R.P.M.)	P, N, D4, D3, D2	422 - 475	61 - 69	455 - 511	66 - 74
		D1	946 - 1324	137 - 192	968 - 1317	140 - 191
		REV.	422 - 475	61 - 69	455 - 511	66 - 74
FULL LINE (1250 R.P.M.)	N, D4, D3, D2		1030 - 1266	150 - 184	1064 - 1302	154 - 189
		D1	946 - 1324	137 - 192	968 - 1317	140 - 191
		REV.	1436 - 1764	209 - 257	1502 - 1838	218 - 267

A ATTACH OIL PRESSURE GAGE

Line pressure is basically controlled by pump output and the pressure regulator valve. In addition, line pressure is boosted in Reverse, and Lo by the reverse boost valve.

Also, in the Neutral, Drive and Reverse positions of the selector lever, the line pressure should increase with throttle opening because of the vacuum modulator.

*The VRV Valve on diesel engines must operate properly.

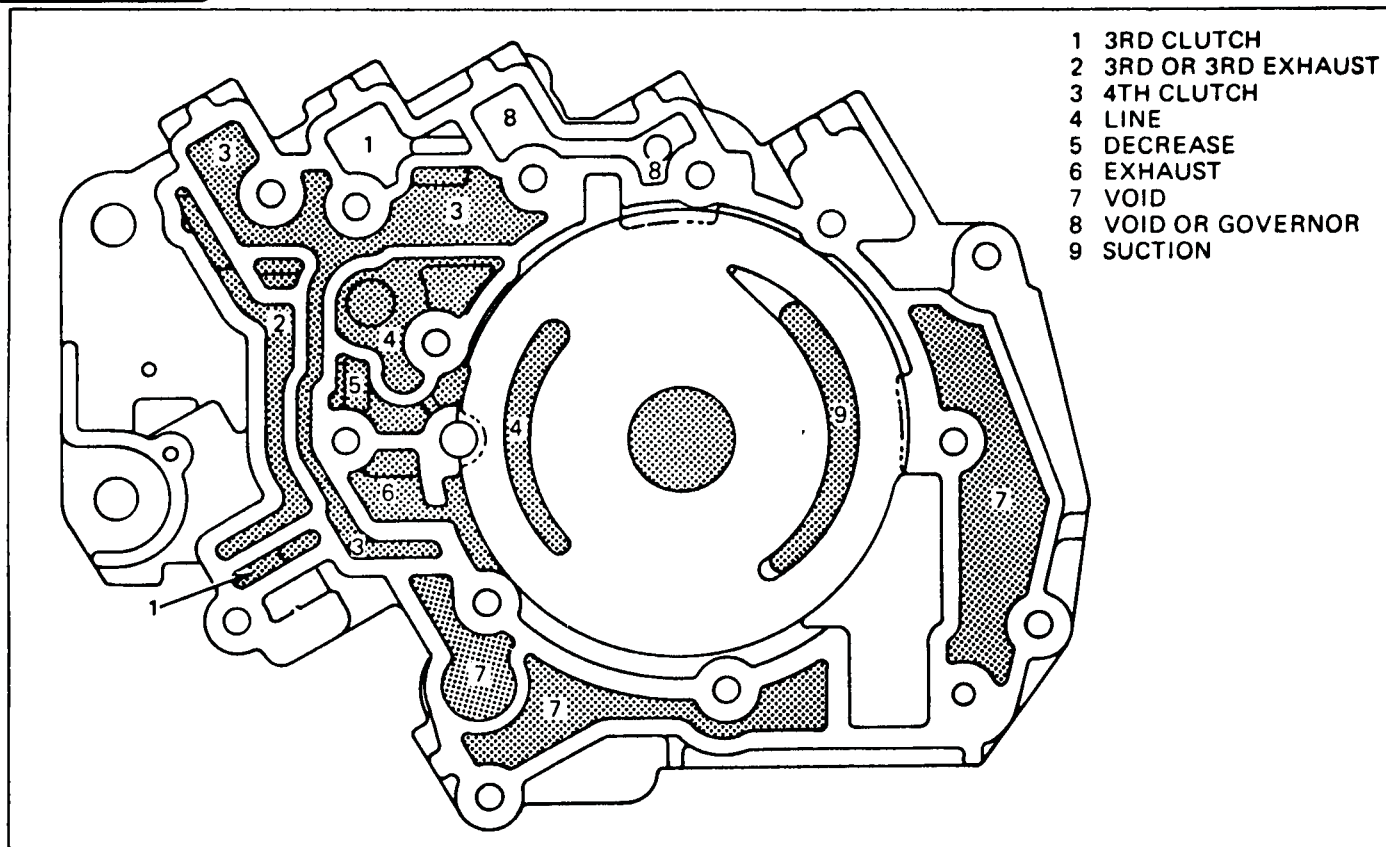

- 1 3RD CLUTCH
- 2 3RD OR 3RD EXHAUST
- 3 4TH CLUTCH
- 4 LINE
- 5 DECREASE
- 6 EXHAUST
- 7 VOID
- 8 VOID OR GOVERNOR
- 9 SUCTION

Figure 117

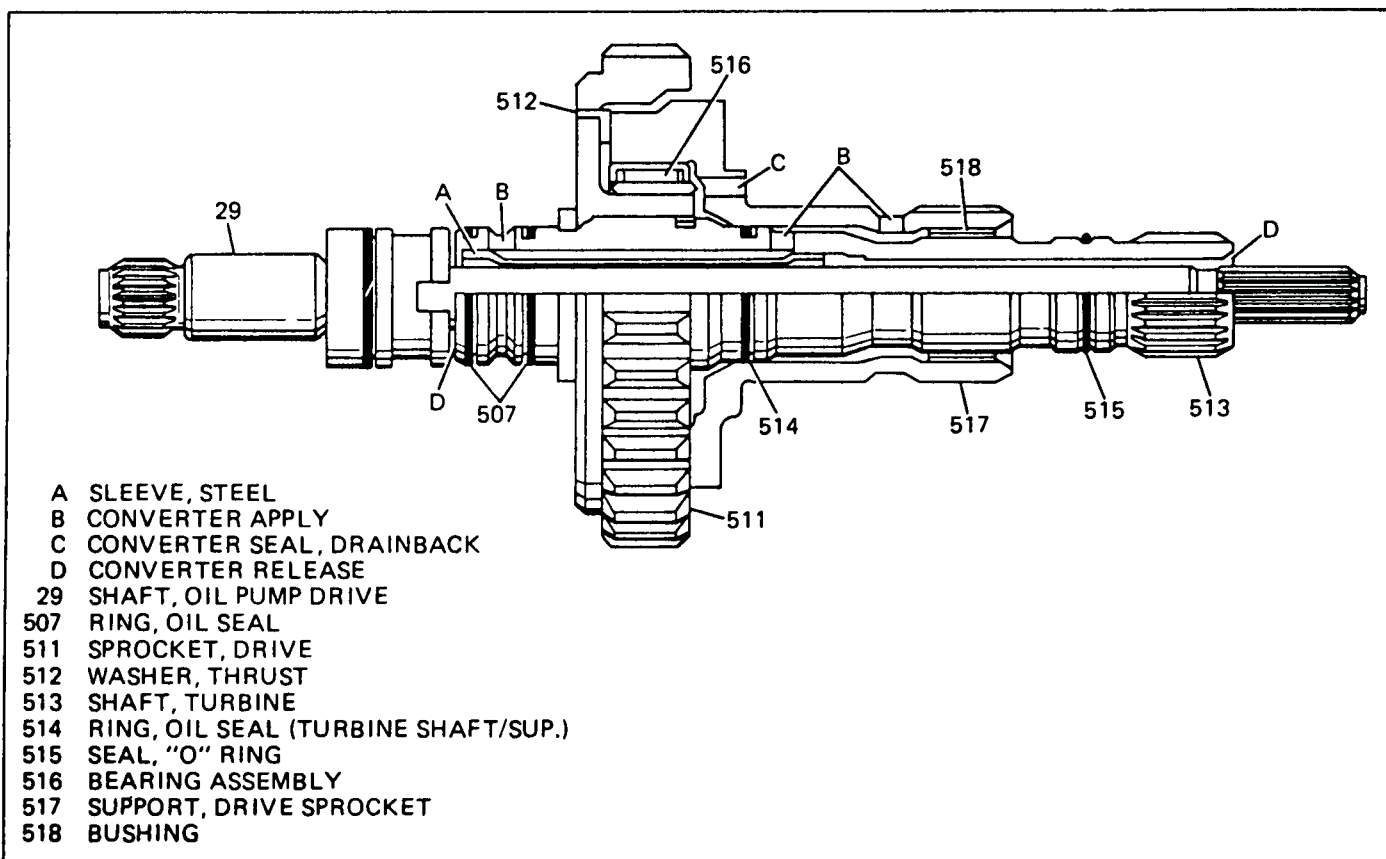

- A SLEEVE, STEEL
- B CONVERTER APPLY
- C CONVERTER SEAL, DRAINBACK
- D CONVERTER RELEASE
- 29 SHAFT, OIL PUMP DRIVE
- 507 RING, OIL SEAL
- 511 SPROCKET, DRIVE
- 512 WASHER, THRUST
- 513 SHAFT, TURBINE
- 514 RING, OIL SEAL (TURBINE SHAFT/SUP.)
- 515 SEAL, "O" RING
- 516 BEARING ASSEMBLY
- 517 SUPPORT, DRIVE SPROCKET
- 518 BUSHING

Figure 118

AUTOMATIC TRANSMISSION SERVICE GROUP

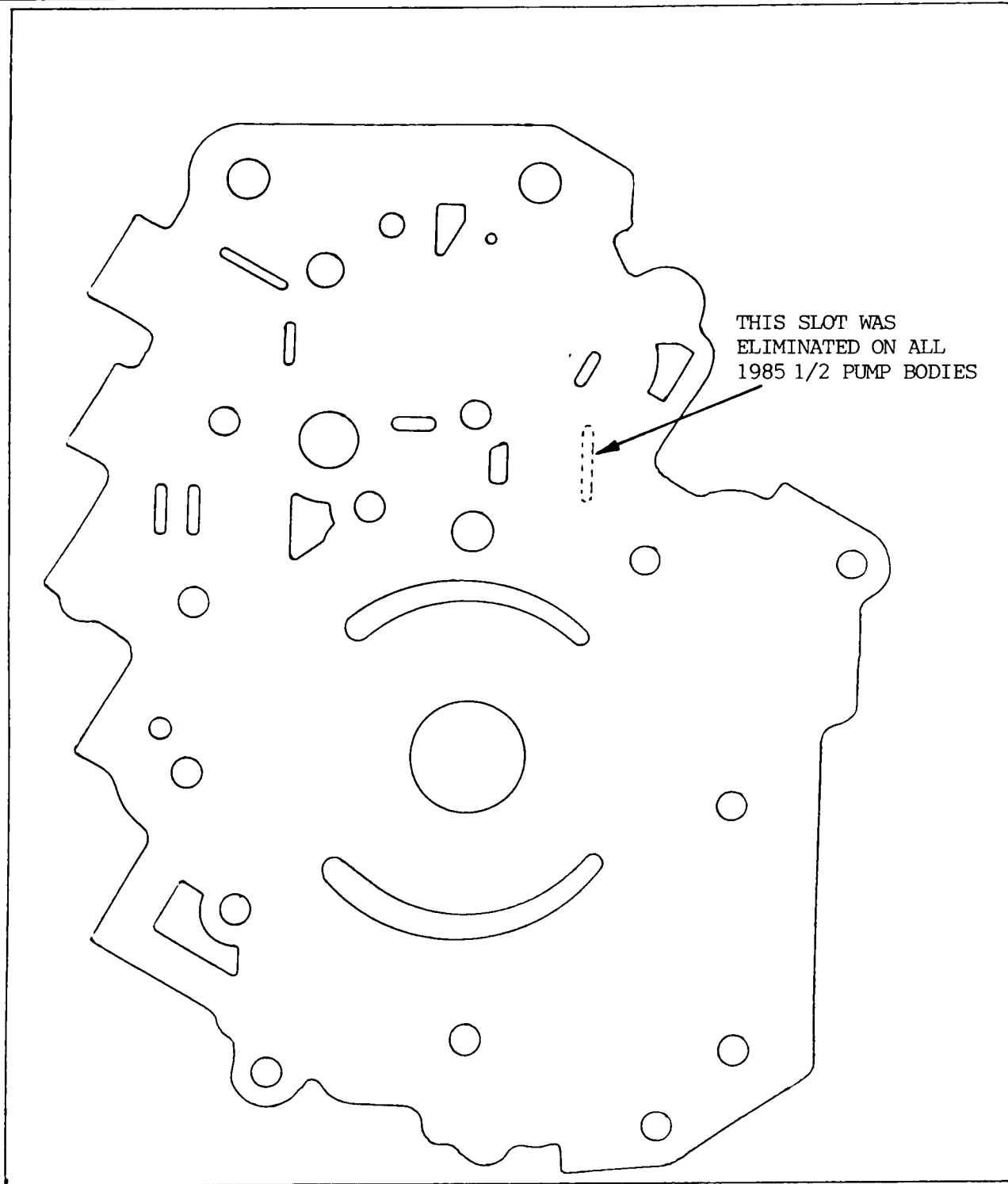
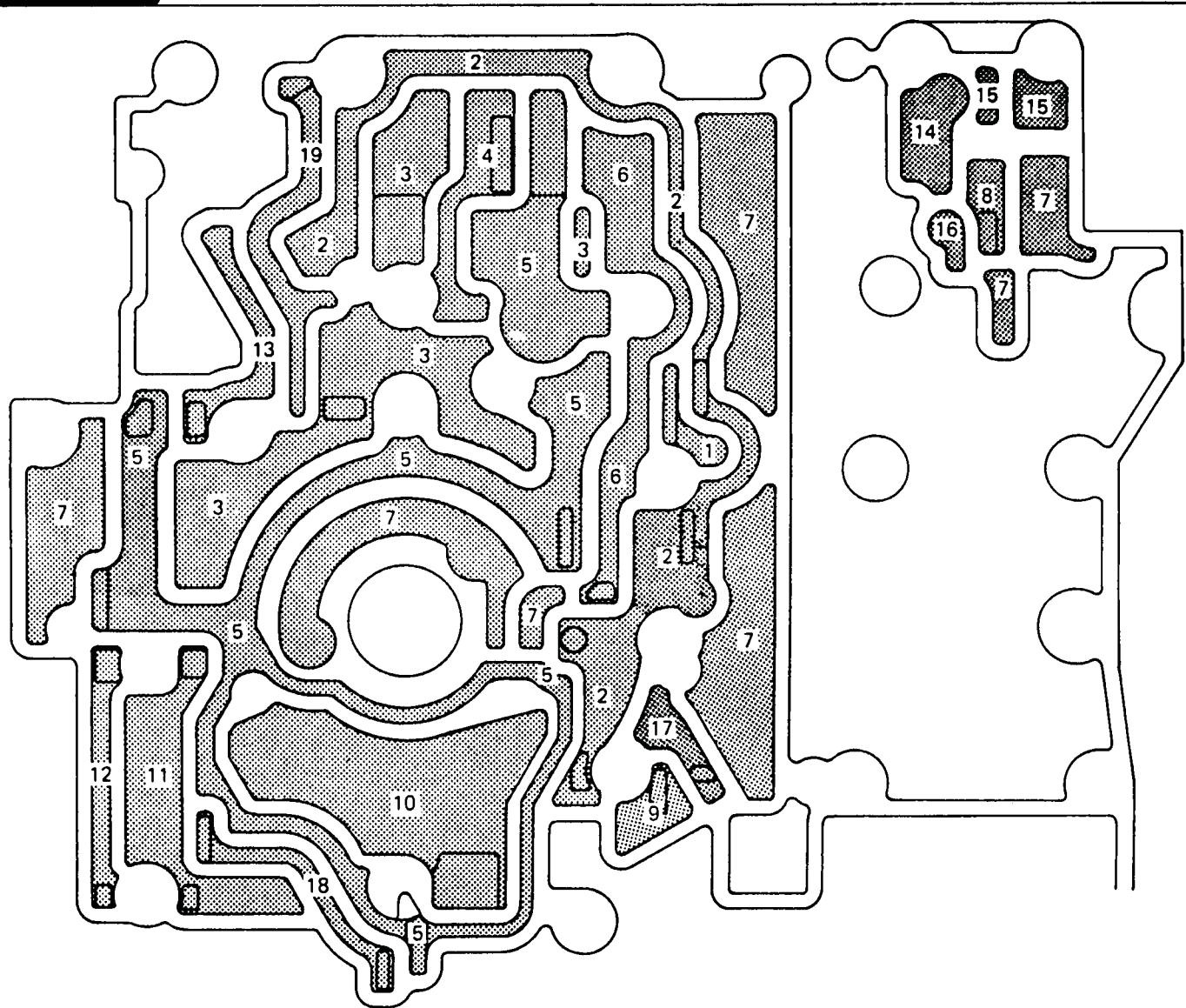

Figure 119



1985 1/2 HYDRAULICS ONLY

VALVE BODY PASSAGES - OIL PUMP SIDE

- 1 4TH CLUTCH
- 2 3RD CLUTCH
- 3 EXHAUST
- 4 DECREASE
- 5 LINE
- 6 3RD/3RD EXHAUST
- 7 VOID
- 8 SERVO RELEASE
- 9 2ND CLUTCH
- 10 SUCTION
- 11 CONVERTER FEED
- 12 CONVERTER CL SIG (OPT. 2ND)
- 13 MODULATOR (T V DIESEL)
- 14 1-2 SERVO
- 15 1-2 SERVO REG APPLY
- 16 DRIVE 4
- 17 2-3 ACCUM EXHAUST
- 18 T.C.C. APPLY
- 19 LO (LO BOOST)

Figure 120

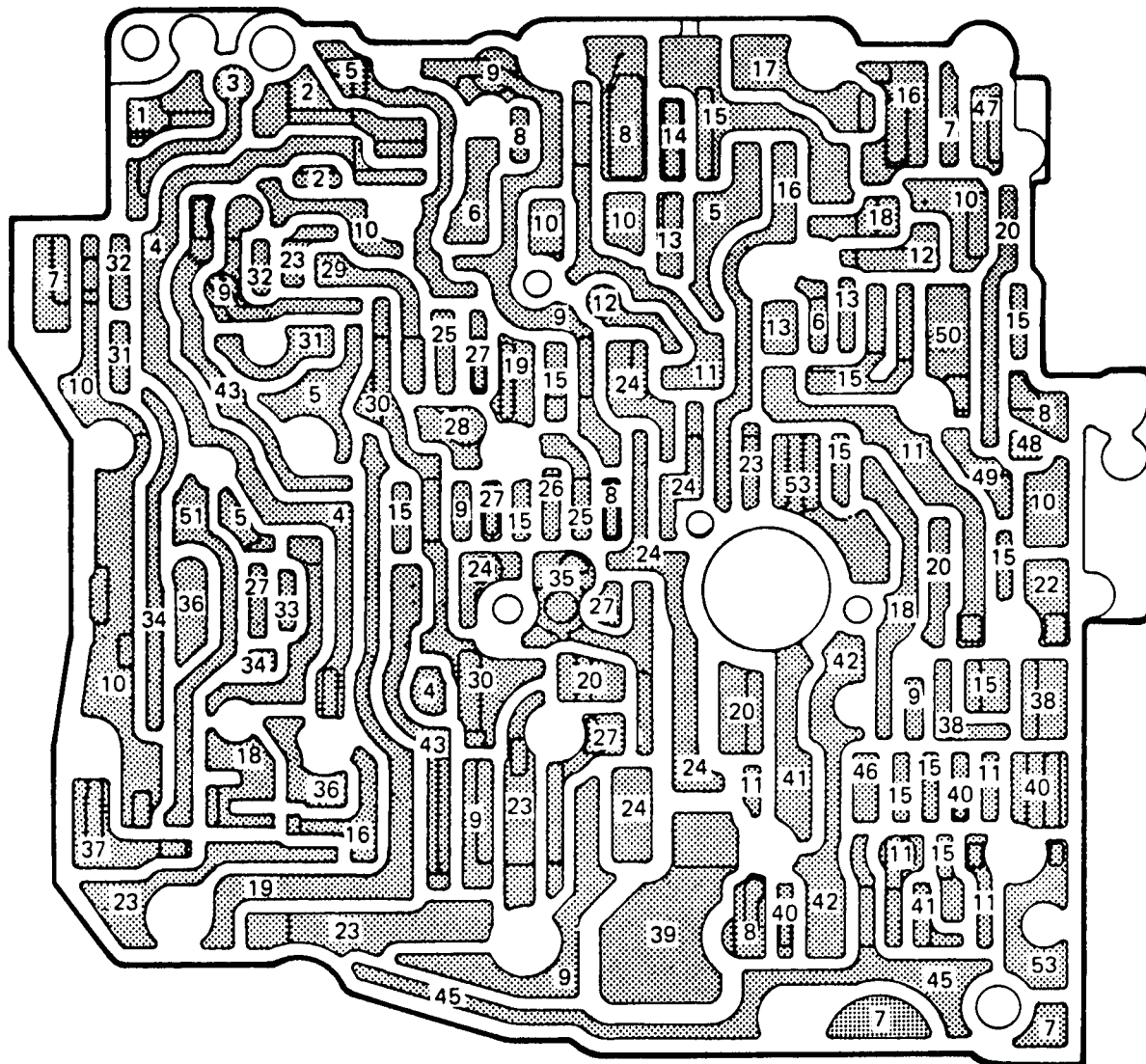

1985 $\frac{1}{2}$ HYDRAULICS ONLY
VALVE BODY PASSAGES - CHANNEL PLATE SIDE

1	REVERSE SERVO FEED	19	4TH CLUTCH	37	T.V./DETENT
2	1-2 SERVO FEED	20	MODULATOR	38	1-2 ACCUMULATOR
3	REVERSE	21	T.V. (OPTIONAL MODULATOR)	39	SUCTION
4	1-2 SERVO	22	CONVERTER CLUTCH SIGNAL	40	T.C.C. APPLY
5	DRIVE 2	23	2ND CLUTCH	41	RELEASE
6	PRND432	24	GOVERNOR	42	APPLY
7	VOID	25	INPUT CLUTCH FEED	43	1-2 SERVO RELEASE
8	LINE	26	DRIVE 3	44	DETENT/3-2 DOWN
9	DRIVE 4	27	3RD CLUTCH	45	COOLER
10	T.V.	28	4TH/4TH EXHAUST	46	EXHAUST/T.V. DIESEL
11	CONVERTER FEED	29	INPUT CLUTCH	47	DET./MOD.-MOD. DIESEL
12	PART THROTTLE	30	2-3 ACCUMULATOR EXHAUST	48	VOID (OPT TV)
13	T.V. FEED	31	PT./D3	49	VOID (OPT DET)
14	DECREASE	32	4-3 MODULATOR	50	TV (DIESEL) MOD (GAS)
15	EXHAUST	33	SERVO RELEASE	51	STV
16	LO	34	3-4 MODULATOR	52	S DET (OPT DET)
17	PRN	35	3RD/3RD EXHAUST	53	CONV CL SIG (OPT 2ND)
18	DETENT	36	LO-1ST		

Figure 121

AUTOMATIC TRANSMISSION SERVICE GROUP

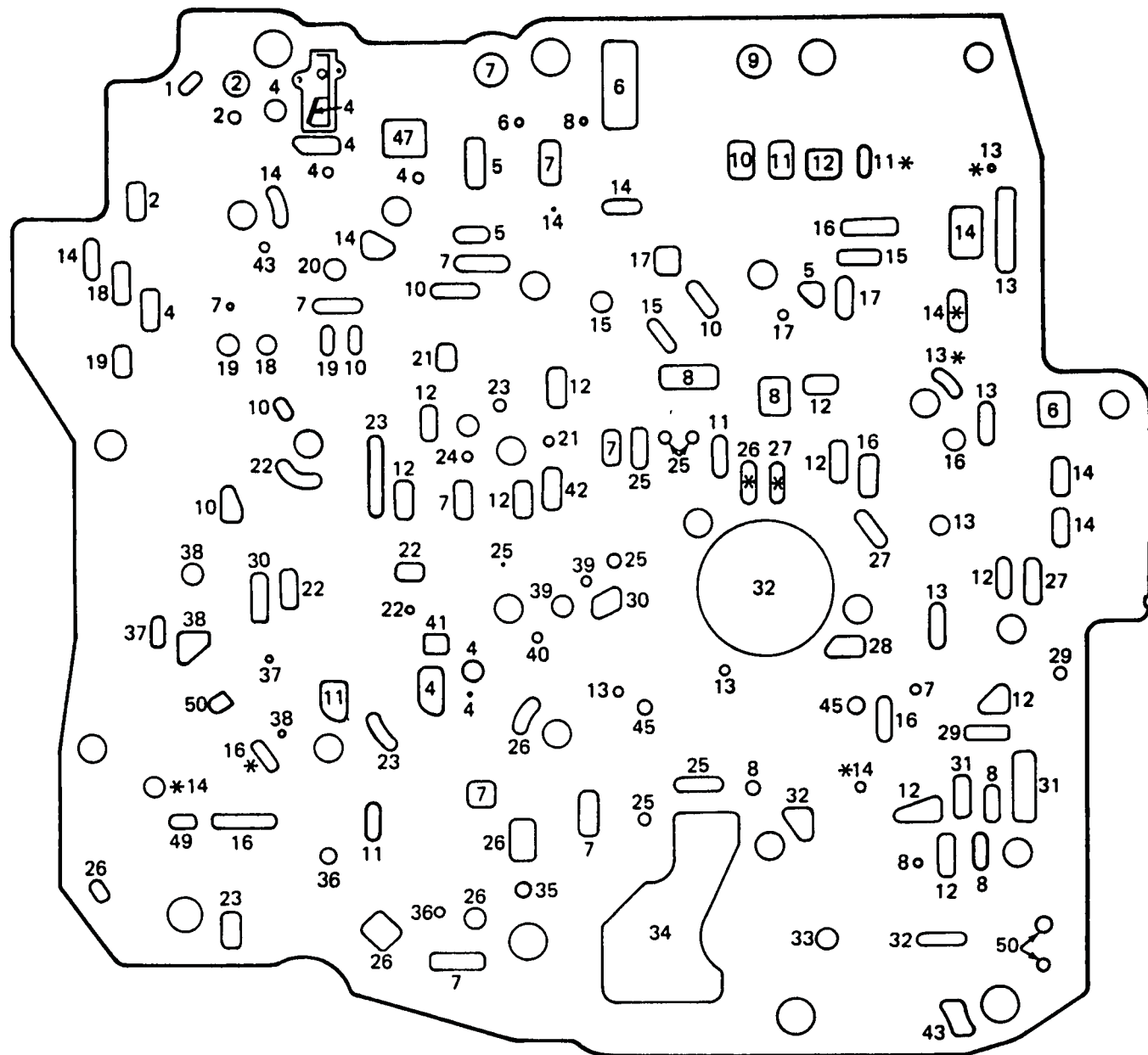

- | | | | | | |
|----|--------------------|----|-------------------------|----|-------------------------|
| 1 | REVERSE SERVO FEED | 18 | 4-3 MODULATOR | 35 | 2ND EXHAUST |
| 2 | REVERSE | 19 | PT./D3 | 36 | 2ND CLUTCH FEED |
| 3 | 1-2 SERVO FEED | 20 | INPUT CLUTCH | 37 | 3-4 MODULATOR |
| 4 | 1-2 SERVO | 21 | INPUT CLUTCH FEED | 38 | LO-1ST |
| 5 | PRND432 | 22 | 1-2 SERVO RELEASE | 39 | 3RD CLUTCH EXHAUST |
| 6 | LINE | 23 | 4TH CLUTCH | 40 | 3RD CLUTCH FEED |
| 7 | DRIVE 4 | 24 | 4TH CLUTCH FEED | 41 | 2-3 ACCUMULATOR EXHAUST |
| 8 | CONVERTER FEED | 25 | GOVERNOR | 42 | DRIVE 3 |
| 9 | PRN | 26 | 2ND CLUTCH | 43 | COOLER |
| 10 | DRIVE 2 | 27 | CONVERTER CLUTCH SIGNAL | 44 | 3-2 DOWNSHIFT |
| 11 | LO | 28 | APPLY | 45 | 3RD/3RD CLUTCH EXHAUST |
| 12 | EXHAUST | 29 | 1-2 ACCUMULATOR | 46 | DETENT/MODULATOR |
| 13 | MODULATOR | 30 | 3RD CLUTCH | 47 | SERVO FEED |
| 14 | T.V. | 31 | T.C.C. APPLY | 48 | S TV or TV |
| 15 | PART THROTTLE | 32 | RELEASE | 49 | S DET or DET |
| 16 | DETENT | 33 | RELEASE OR APPLY | 50 | CONV CL SIG (OPT 2ND) |
| 17 | T.V. FEED | 34 | SUCTION | | |

* OPTIONAL (DETERMINED BY PART NUMBER)

1985 $\frac{1}{2}$ HYDRAULICS ONLY

Figure 122

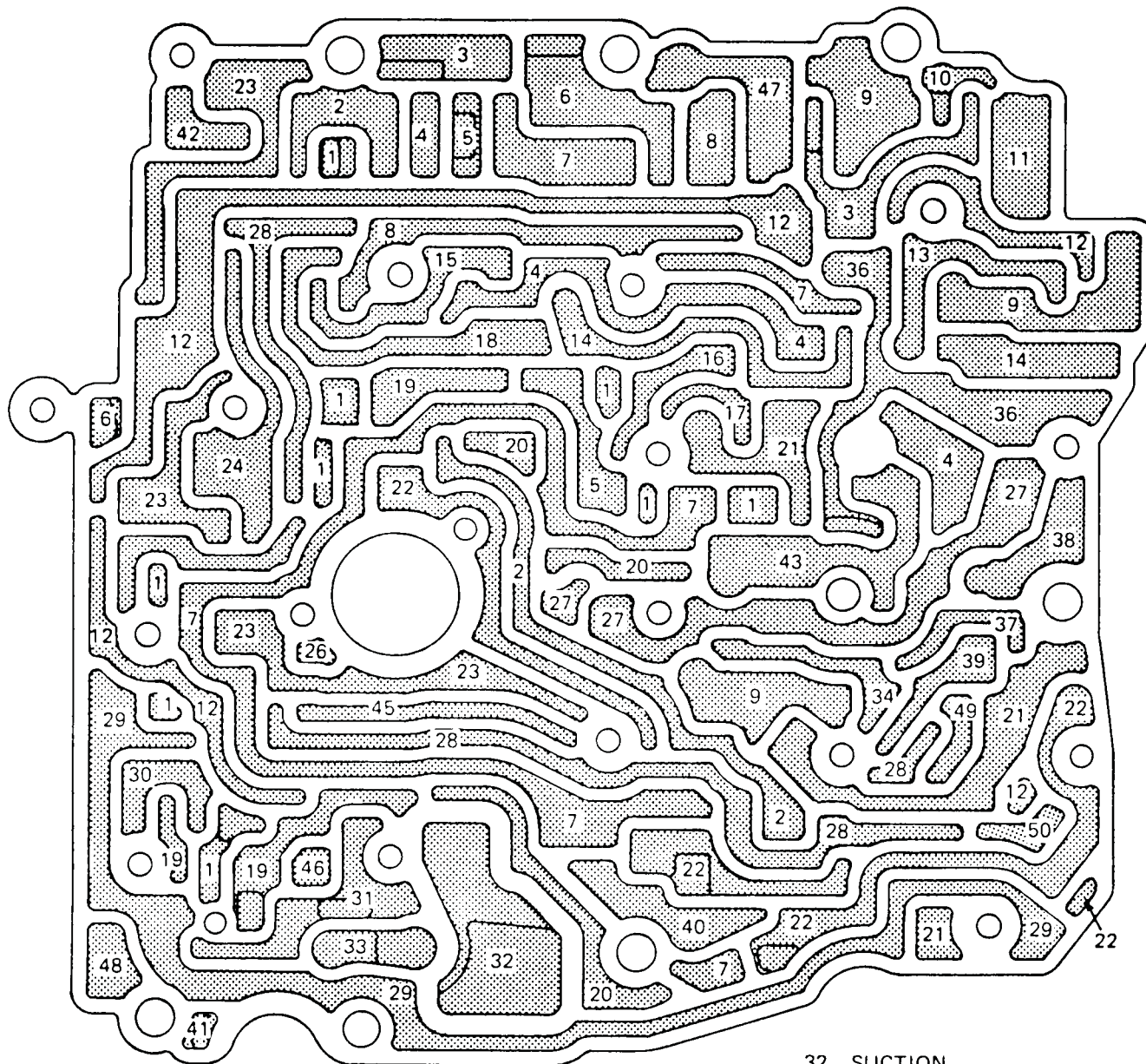

1985½ HYDRAULICS ONLY

- | | | |
|-----------------------------|--|----------------------------|
| 1 EXHAUST | 17 4TH OR 4TH EXHAUST | 32 SUCTION |
| 2 LO | 18 PART THROTTLE | 33 RELEASE OR APPLY |
| 3 PRN | 19 CONVERTER FEED | 34 2-3 ACCUMULATOR EXHAUST |
| 4 DRIVE 2 | 20 GOVERNOR | 35 SERVO RELEASE |
| 5 DRIVE 3 | 21 4TH CLUTCH | 36 INPUT CLUTCH OR REVERSE |
| 6 LINE | 22 2ND CLUTCH | 37 3-4 MODULATOR |
| 7 DRIVE 4 | 23 MODULATOR | 38 3RD CLUTCH / LO-1ST |
| 8 PRND432 | 24 DETENT (OPT. EXHAUST
OR PART THROTTLE) | 39 LO-1ST |
| 9 1-2 SERVO | 25 CONVERTER CLUTCH SIGNAL | 40 2ND OR 2ND EXHAUST |
| 10 REVERSE SERVO FEED | 26 APPLY | 41 COOLER |
| 11 REVERSE | 27 3RD CLUTCH | 42 DETENT/MODULATOR |
| 12 T.V. | 28 DETENT | 43 1-2 SERVO RELEASE |
| 13 4-3 MODULATOR | 29 1-2 ACCUMULATOR | 44 3-2 DOWNSHIFT |
| 14 PART THROTTLE OR DRIVE 3 | 30 T.C.C. APPLY | 45 3RD CL / 3RD CL EXHAUST |
| 15 T.V. FEED | 31 RELEASE | 46 VOID |
| 16 INPUT CLUTCH FEED | | 47 1-2 SERVO FEED |
| | | 48 CONV CL SIG (OPT 2ND) |
| | | 49 S DET (OPT DET) |
| | | 50 S TV (OPT TV) |

CHANNEL PLATE PASSAGES - VALVE BODY SIDE

Figure 123

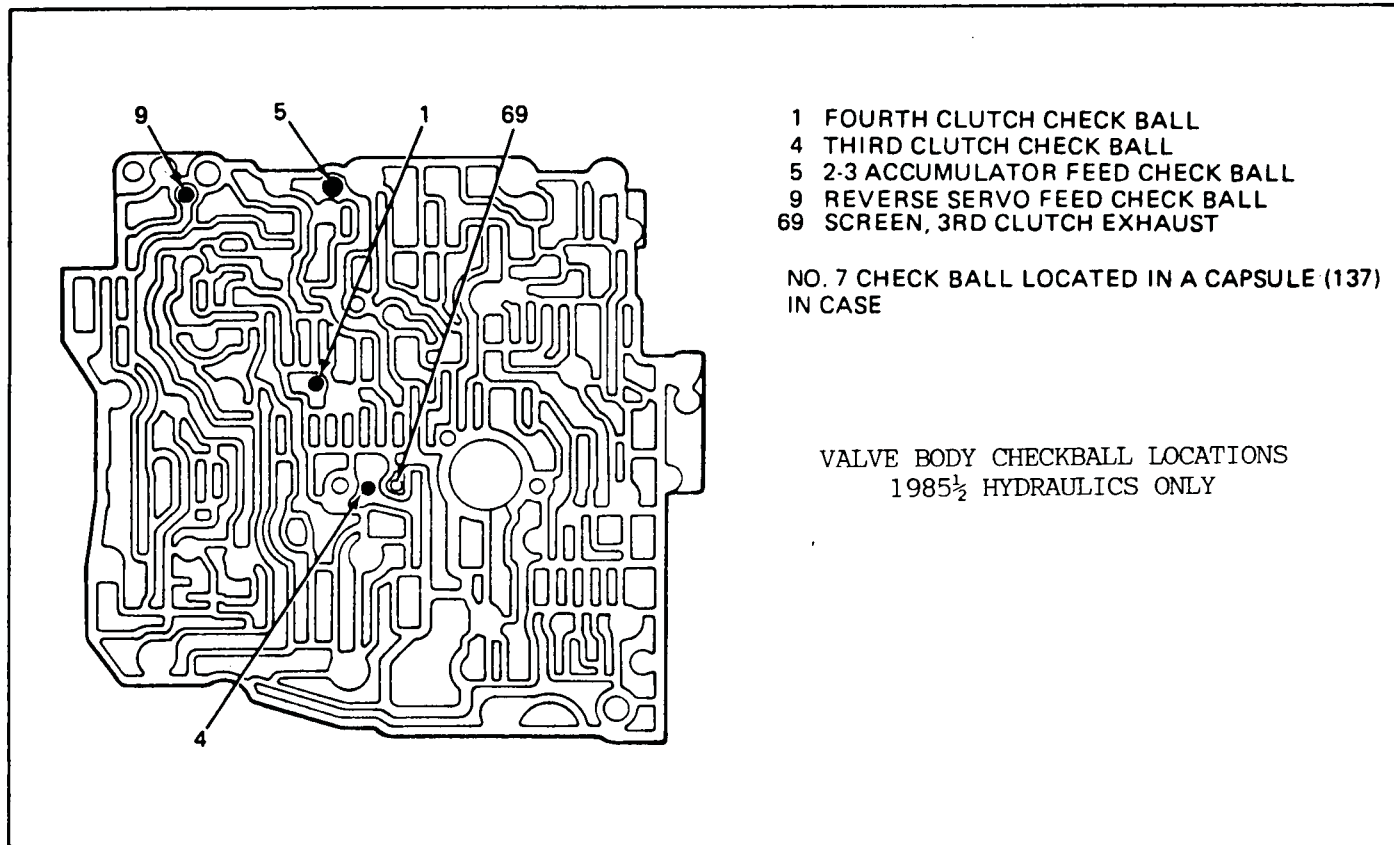

Figure 124

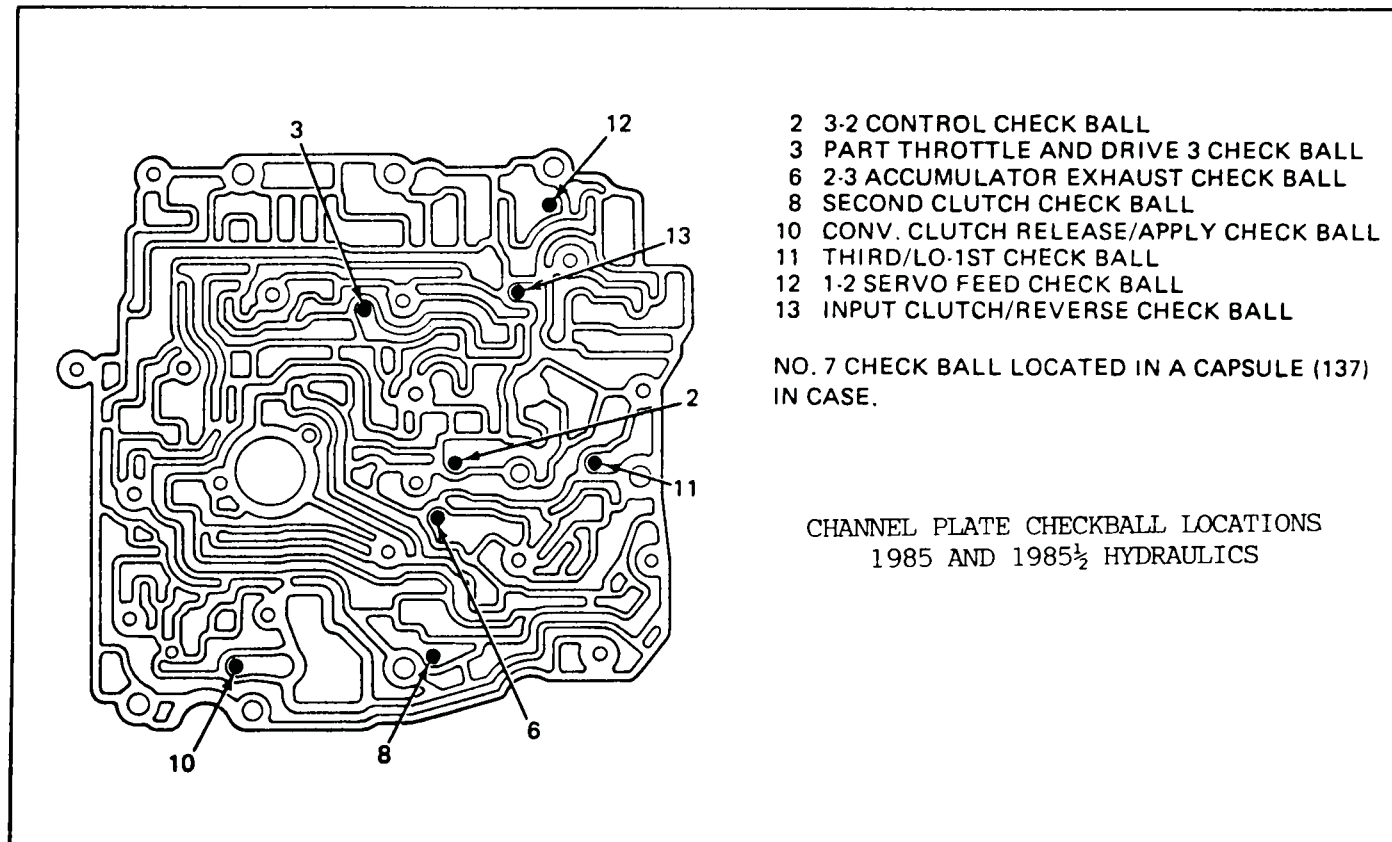

Figure 125

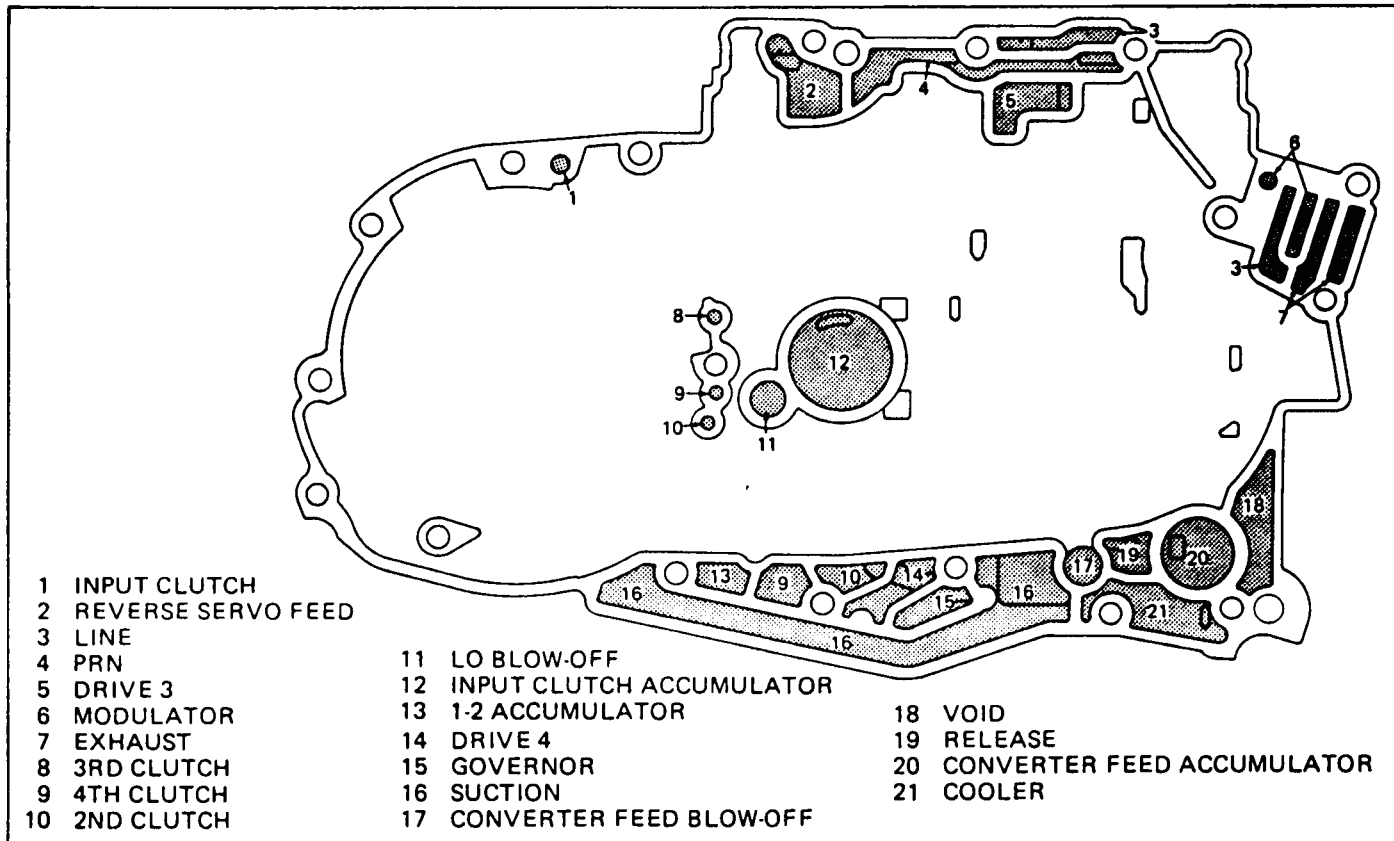

Figure 126

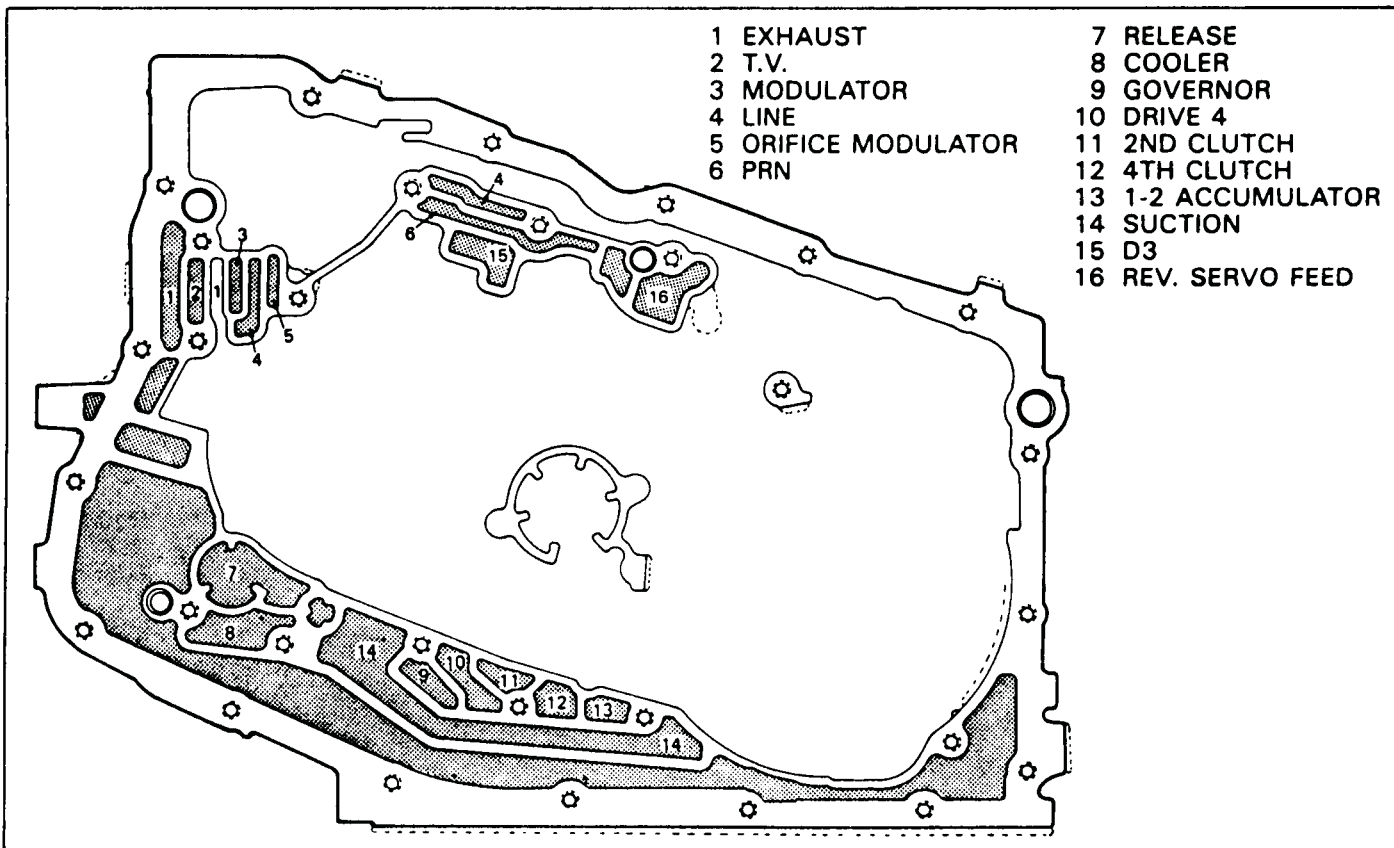

Figure 127

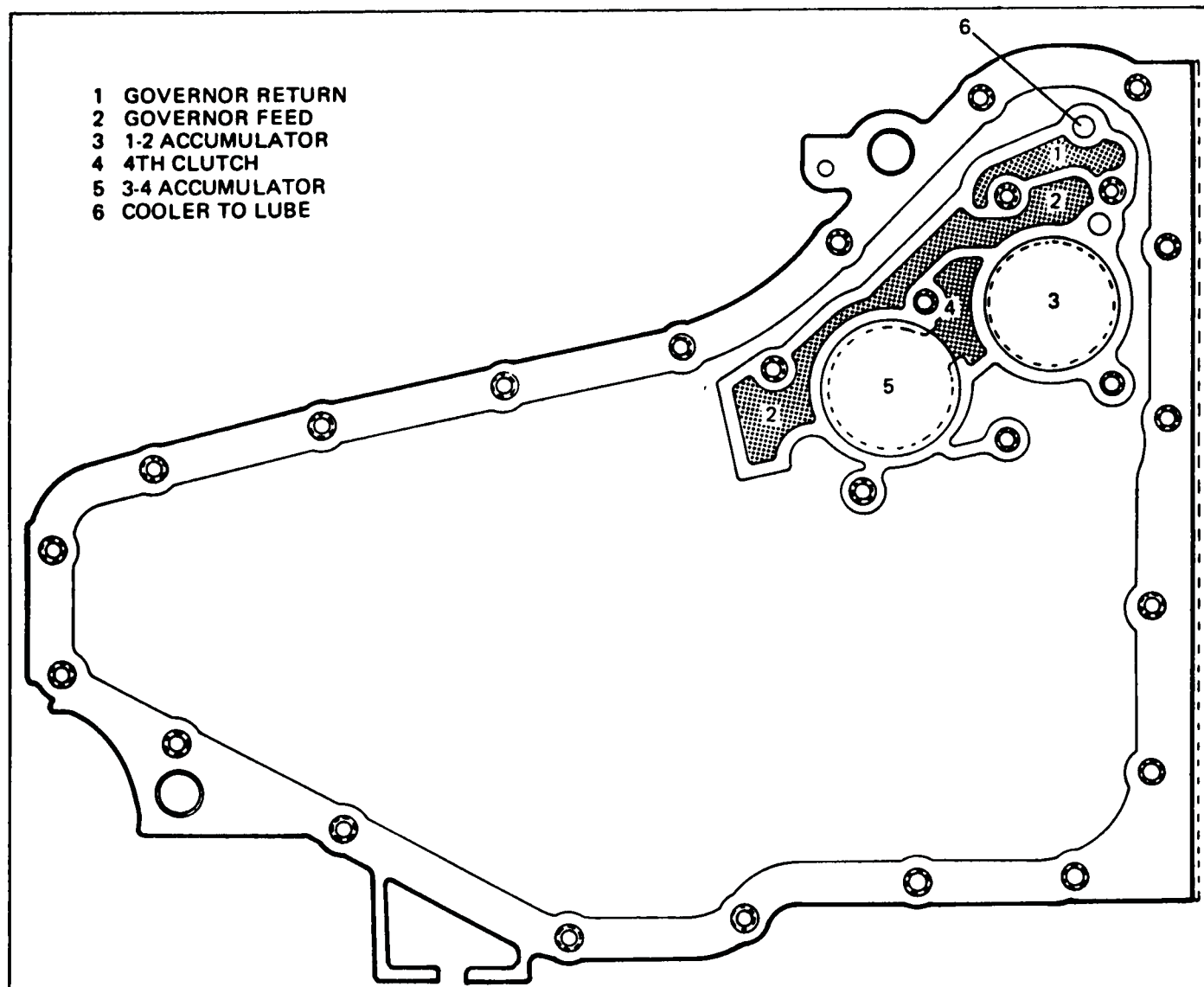

Figure 128

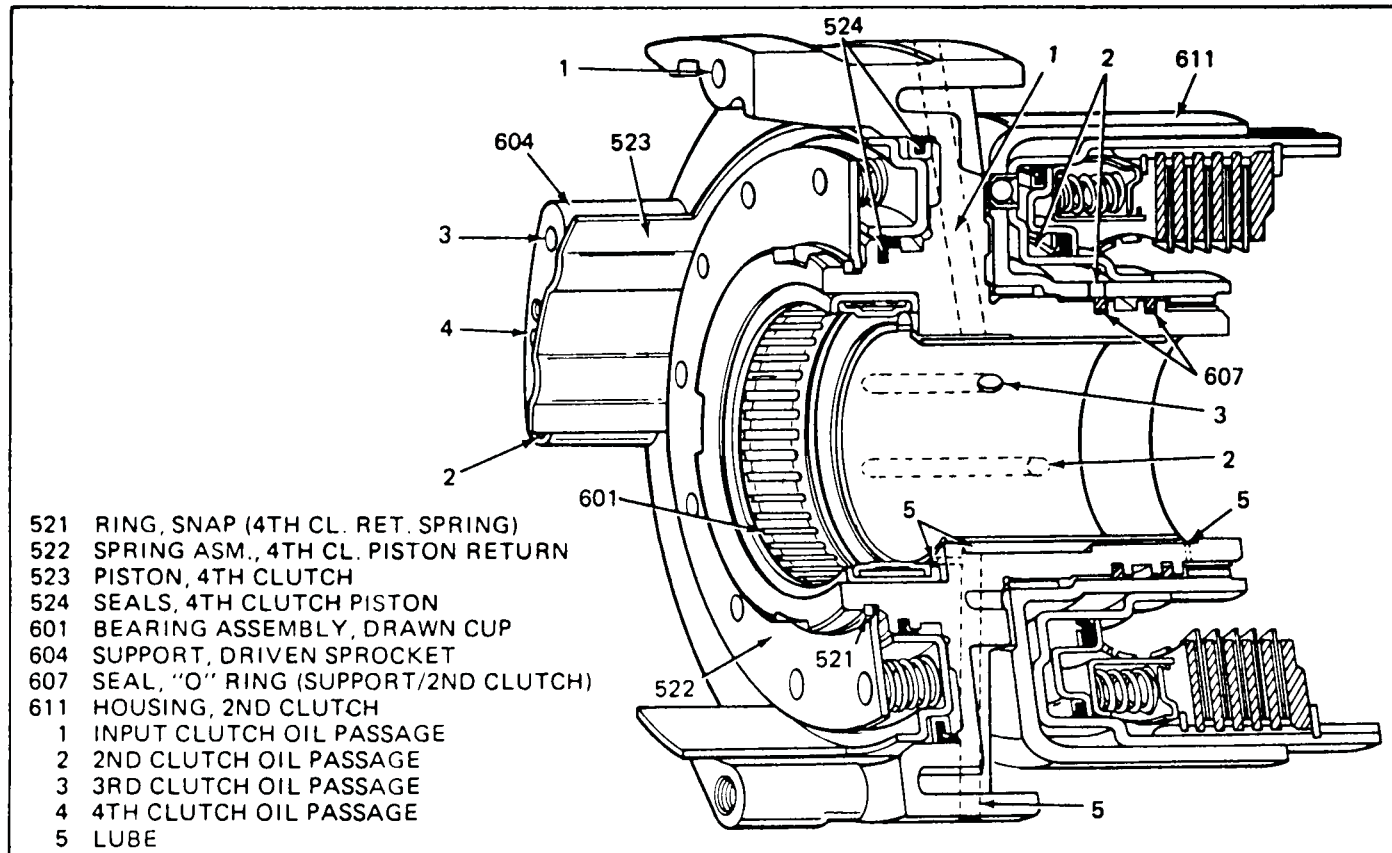

Figure 129

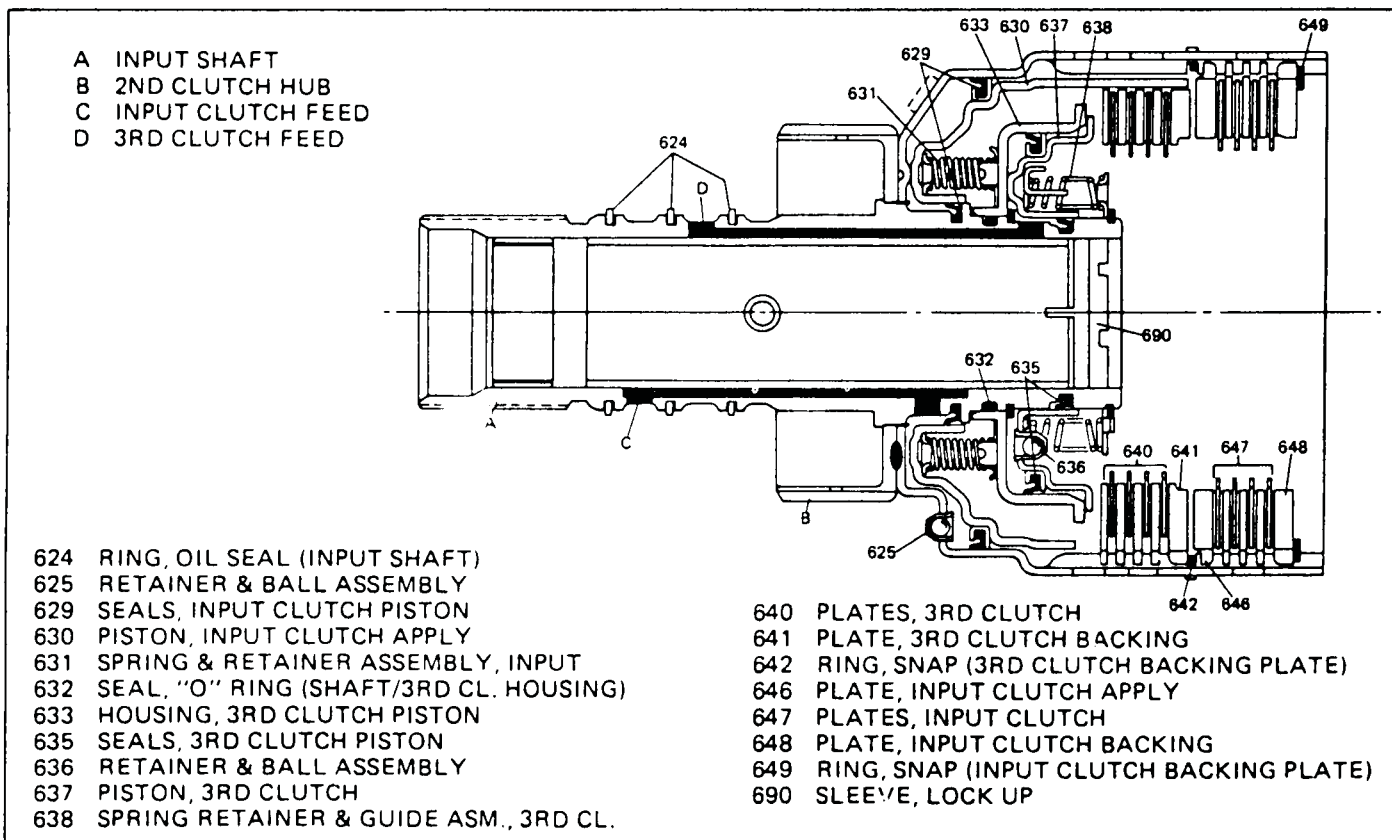

Figure 130