



INDEX

1980 Changes	4
1981 Changes	6
Driven Sprocket Sleeve	12
3rd Accumulator Check Valve	14
1982 Changes	18
Converter Seal Blowout	24
1983 Changes	29
3-2 Coastdown Clunk	31
1984 Changes	34
Checking Drive Chain	41
1985 Changes	44
1986 Changes	49
1987 Changes	51
1982 Identification	60
1983 Identification	62
1984 Identification	64
1985 Identification	66
1986 Identification	68
1987 Identification	70
Case Identification	72

Information and part numbers contained in this handbook have been carefully compiled from industry sources known for their reliability, but ATSG does not guarantee its accuracy.

"This publication contains copyright material of General Motors Corporation and Hydra-Matic Division, General Motors Corporation. It is reprinted with the permission of the copyright owner."

AUTOMATIC TRANSMISSION SERVICE GROUP



INTRODUCTION THM 125C

Since the introduction of the THM 125 transaxle in model year 1980, there have been many major engineering changes. These changes have affected nearly every part used in the 125 and 125c.

This Update Handbook will explain each change, the parts affected by the change, any parts interchangeability problems created by the change. This Update Handbook will cover all of the changes from start of production up through and including model year 1987, along with common problems, and fixes, for the THM 125 transaxle.

The THM 125 was produced in model years 1980, 81 and early 1982. The THM 125C transaxle, introduced in early 1982, provided the addition of a converter clutch torque converter. The converter clutch was added to increase fuel economy by eliminating the fluid coupling of the transaxle at road load conditions, replacing it with a direct mechanical connection.

Application of the converter clutch is controlled automatically by the computer (ECM).

COPYRIGHT A.T.S.G.© 1988

The information and part numbers contained in this booklet have been carefully compiled from industry sources known for their reliability, but ATSG does not guarantee its accuracy.

ROBERT D. CHERRNAY
TECHNICAL DIRECTOR

DALE ENGLAND
FIELD SERVICE CONSULTANT

FRANK MIETUS
TECHNICAL CONSULTANT

WAYNE COLONNA
TECHNICAL CONSULTANT

WELDON BARNETT
TECHNICAL CONSULTANT

ED KRUSE
LAY OUT

AUTOMATIC TRANSMISSION SERVICE GROUP
9200 SOUTH DADELAND BLVD.
SUITE 720
MIAMI, FLORIDA 33156
(305) 661-4161

1987 TRANSMISSION APPLICATIONS

PASSENGER CARS BY BODY TYPE

G.M. BODY TYPE	TRANSMISSIONS USED	BUICK	CADILLAC	CHEVROLET	OLDSMOBILE	PONTIAC
A	125C & 440-T4	CENTURY		CELEBRITY	CIERA CUTLESS CRUISER	6000
B	200-4R, 200C & 700-R4	LESABRE ESTATE WAGON		CAPRICE	CUSTOM CRUISER	PARISIENNE
C	440-T4	ELECTRA	DEVILLE FLEETWOOD		98 REGENCY	
D	200-4R		FLEETWOOD BROUGHAM			
E/K	440-T4	RIVIERA	ELDORADO *SEVILLE		TORONADO	
F	700-R4			CAMARO		FIREBIRD
G**	200C & 200-4R	REGAL		MONTE CARLO	CUTLASS SUPREME	GRAND PRDX
H	440-T4	LE SABRE			DELTA 88	BONNEVILLE
J	125C	SKYHAWK	CIMARRON	CAVALIER	FIRENZA	SUNBIRD
L	125			CORSICA BERETTA		
N	125C	SKYLARK SOMERSET			CALAIS	GRAND AM
P	125C					FIERO
T	180C			CHEVETTE		T1000
V	F-7		ALLANTE			
Y	700-R4			CORVETTE		

**G BODY COMPONENTS ARE SHARED WITH THE CHEVROLET EL CAMINO AND THE GMC CABALLERO

TRUCKS AND BUSES

TRANSMISSION USED	G.M. BODY TYPE						
	C, ZWD STD.	K 4X4 PICKUP	G VAN	M SMALL VAN	P FORWARD CONTROL	S, ZWD SMALL PICKUP	T 4X4 PICKUP
400	CHEVY & GMC-PICKUP		CHEVY-BEAUVILLE CHEVY-SPORT VAN GMC-VANDURA GMC-RALLY		CHEVY & GMC STEP VAN & SPECIAL APPLICATIONS		
700-R4	CHEVY & GMC-PICKUP CHEVY-BLAZER GMC-JIMMY CHEVY & GMC-SUBURBAN		CHEVY-BEAUVILLE CHEVY-SPORT VAN GMC-VANDURA GMC-RALLY	GMC SAFARI ASTRO		CHEVY & GMC-PICKUP CHEVY-BLAZER GMC-JIMMY	



Technical Service Information

Beginning November 1, 1980, a new design final drive ring gear spacer went into production. (See Figure 1).

The 2nd design ring gear spacer is completely interchangeable with the 1st design ring gear spacer. Compressing the 2nd design spacer may be necessary for easier installation and removal.

NOTE: The parking pawl opening in either design spacer must be aligned with the parking pawl opening in the case.

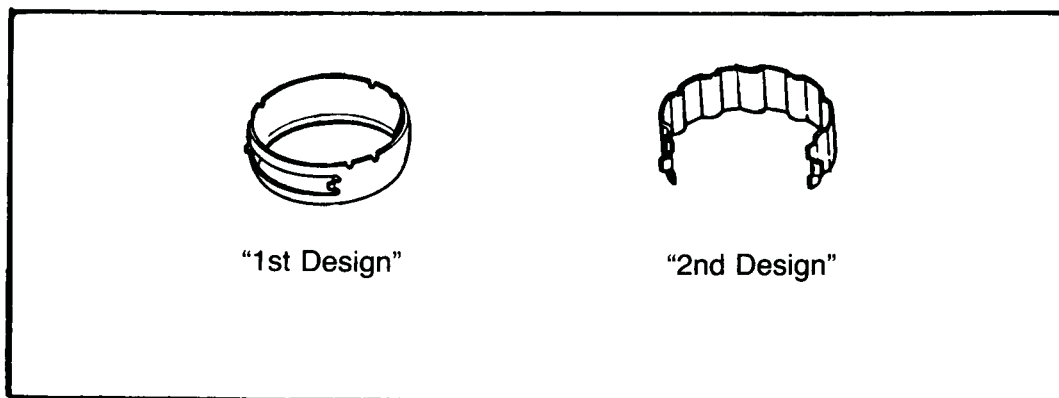

Figure 1

In mid-september, 1980, design changes on the drive sprocket support made it necessary to install the converter bushing $5/64$ " deeper inside of the converter hub.

For identification, the 1st design support has an undercut shaft and the 2nd design support has a radius shaft (See Figure 2).

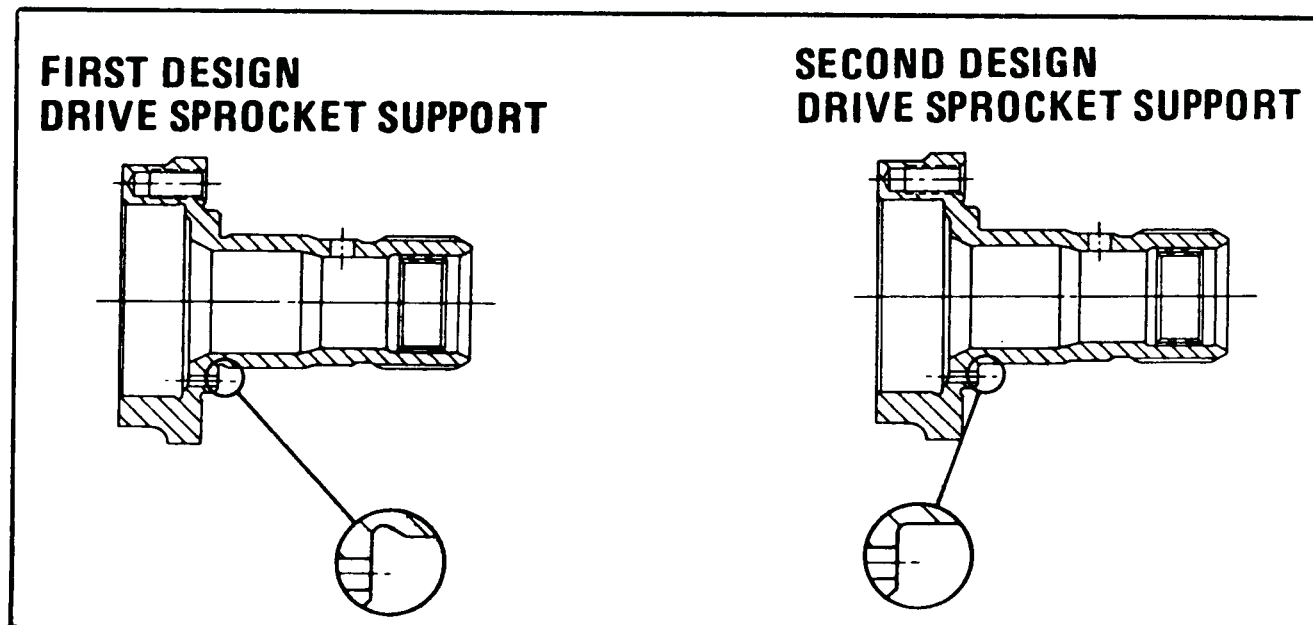

Figure 2



Technical Service Information

In late 1980, the case cover was modified with an extra hole cast into it, to eliminate the possibility of an "oil out the vent" condition.

If you should encounter a case cover without the hole, use a 1/4" drill, and make a 1/4" hole through the case cover under the breather as shown in Figure 3.

Late 1980 production has this passage and does not require drilling.

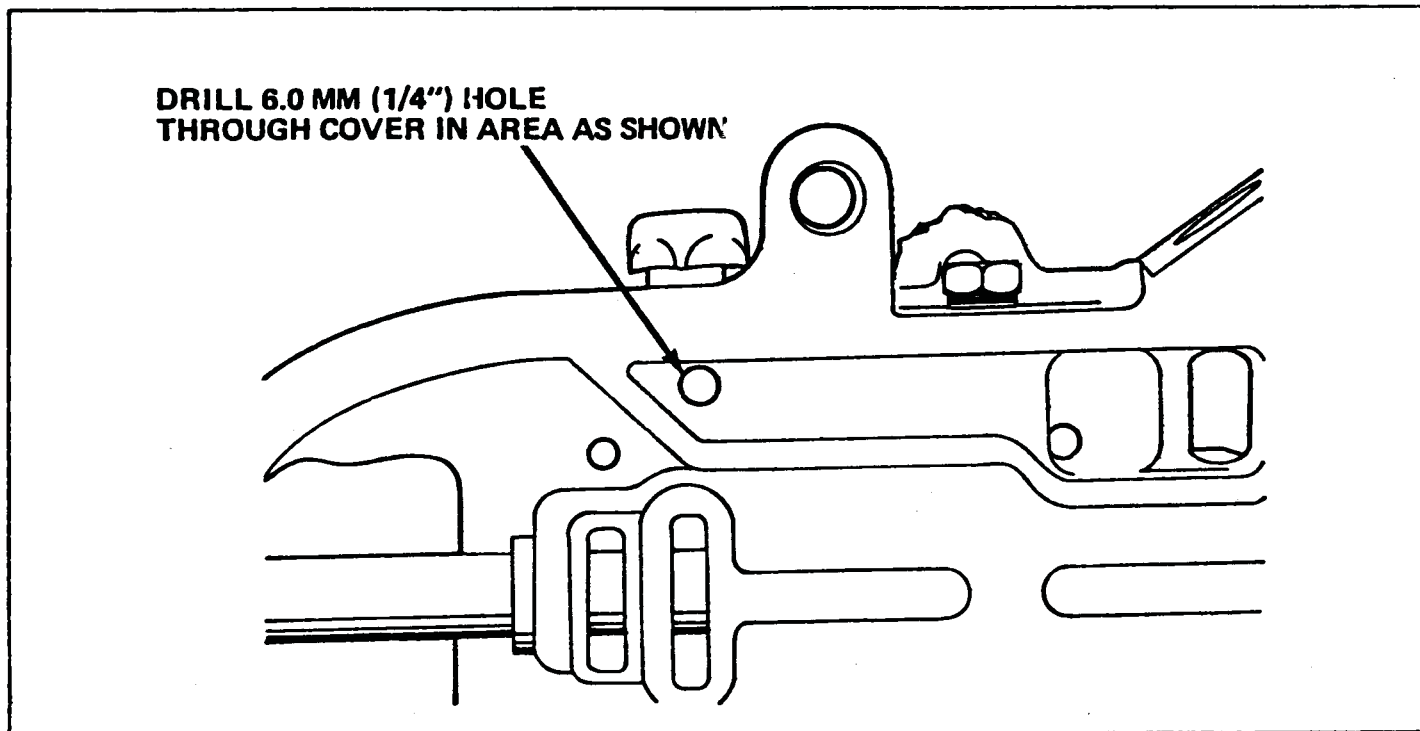

Figure 3



Technical Service Information

Beginning in early March, 1981, THM 125 transaxles were built with a new design one piece input drum (Sun Gear Shell) to provide better lube oil to the input carrier and improved durability. The low and reverse clutch housing also had to be redesigned to accommodate the revised input drum. See Figures 4 and 5.

The 2nd design input drum (Sun Gear Shell) has scoops stamped into the drum, replacing the 1st design roll pins (See Figure 4). The low and reverse clutch housing is redesigned to allow clearance for the new scoops on the input drum (See Figure 5).

Either the 1st design or 2nd design input drum can be used with the 2nd design low and reverse clutch housing; however, the 2nd design is highly recommended over the previous design.

“DO NOT” use the 2nd design input drum with the past design low and reverse clutch housing or interference will result.

Input Drum (2nd Design)	8637511
Low and Reverse Clutch Hsg. (2nd Design)	8637514

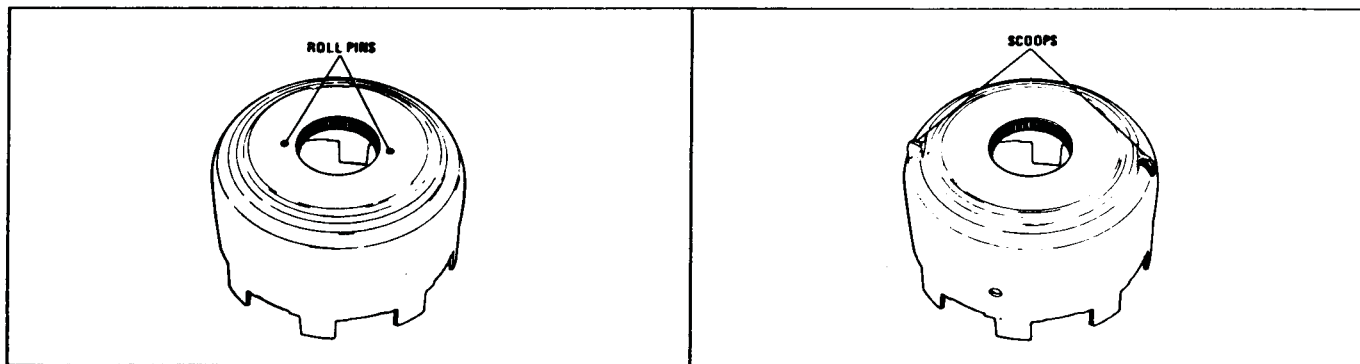

1st Design

2nd Design

Figure 4

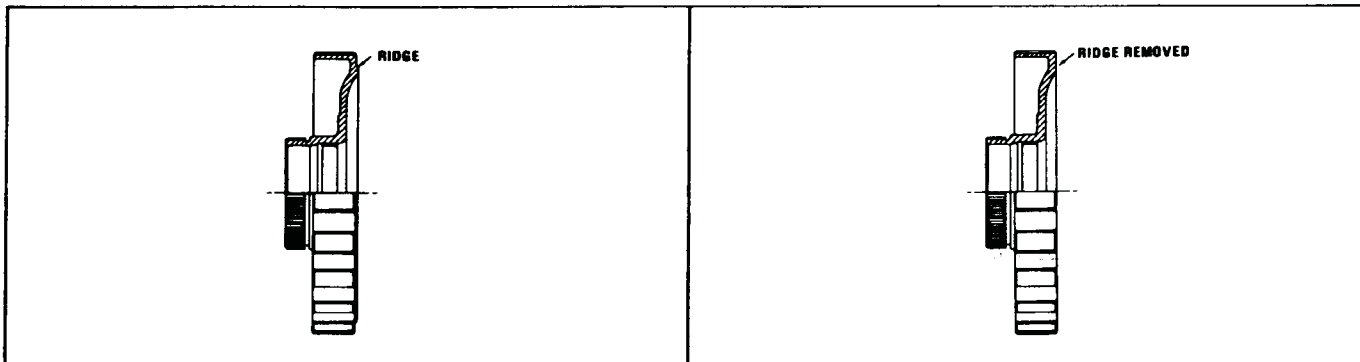

1st Design

2nd Design

Figure 5



Technical Service Information

Beginning mid-March, 1981, THM 125 transaxles were built with a new design governor cover bearing in place of the past design thrust washer. This bearing will be one of two designs, (1) a three piece thrust bearing assembly or (2) a one piece bearing (See Figure 6). For service, only the three piece bearing will be used.

A new design governor cover was also put into production. The height of the governor hub was reduced to allow clearance for the increased thickness of the bearing. (See Figure 7).

This design change was made to reduce friction between the speedometer gear and governor cover during high speed, long distance driving.

- NOTE: 1) Do not use the three piece bearing assembly or the one piece bearing with the past design governor cover. This combination would not allow proper clearance between the speedometer drive gear and governor cover, causing wear on the governor gear and eventually no upshift.
- 2) Do not use the past design thrust washer with the new design governor cover. This combination would have excess endplay between the speedometer drive gear and the governor cover, causing erratic shifts and speedometer gear wear.

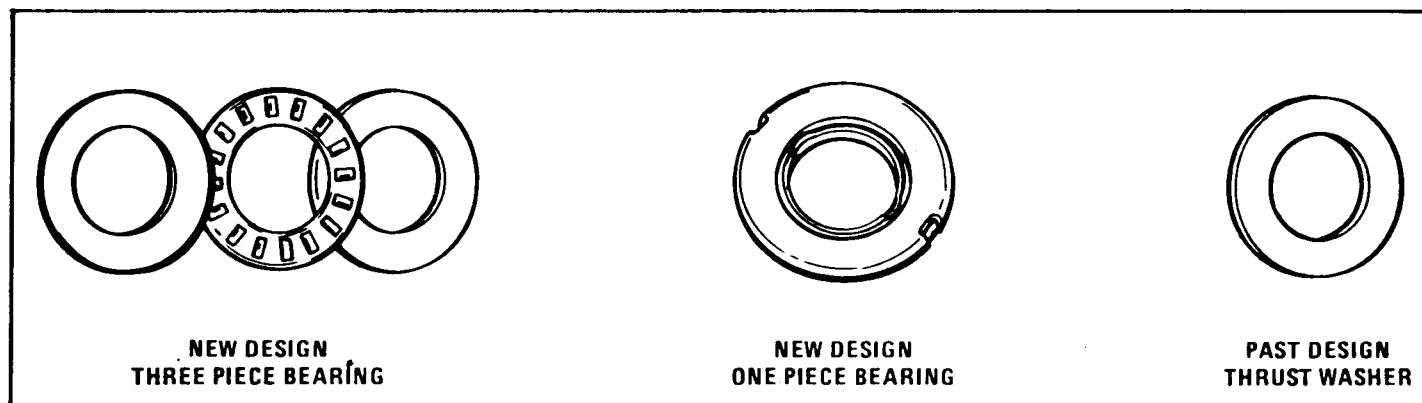

Figure 6

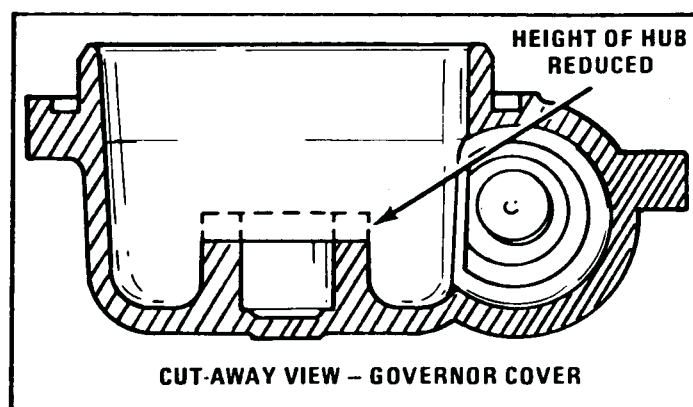

Figure 7

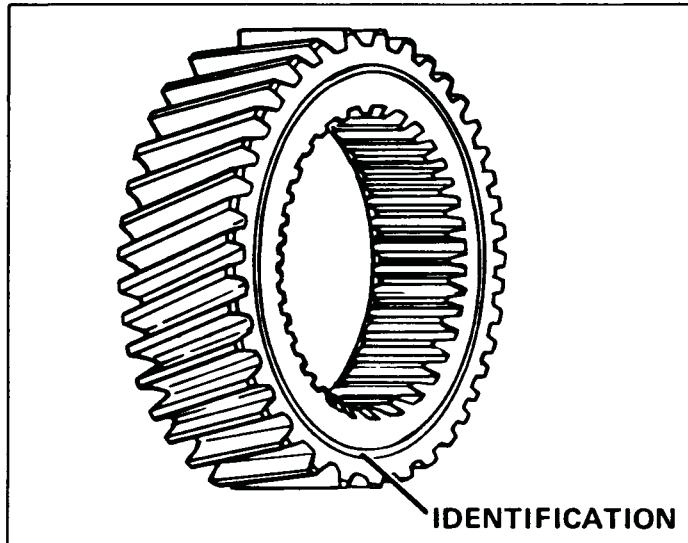

Figure 8

Beginning March, 1981, all THM 125 input sun gears were manufactured with an identification groove as shown in Figure 8. The input sun gear must be installed in the transaxle with this I.D. groove toward the sun gear shell.

Beginning mid-July, 1981, a new design direct clutch backing plate was used on all THM 125 models (See Figure 9).

The new design backing plate has a raised side for identification, and a flat side, which when assembled, should face toward the clutch plates.

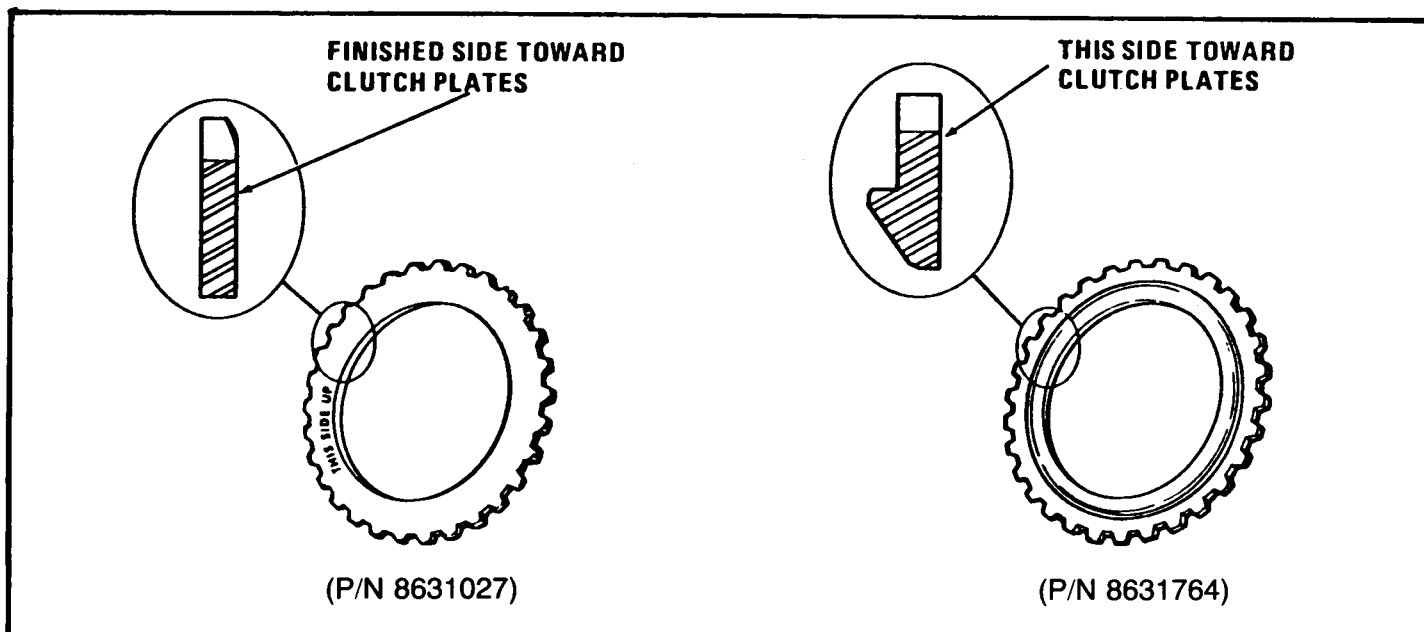

Figure 9

In early May, 1981, some THM 125 transaxles were built with R.T.V. Silicone sealant on the valve body cover and bottom oil pan in place of the cork gaskets. The flange on both the valve body cover and the oil pan were redesigned to eliminate the stiffening rib (Figure 10), making the flange face flat (Figure 11).

Oil pans with raised stiffening ribs on the flange as in Figure 10, must not be assembled with R.T.V. sealant.

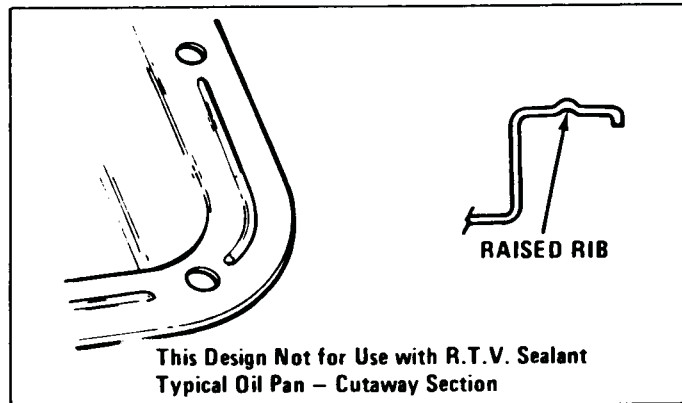

Figure 10

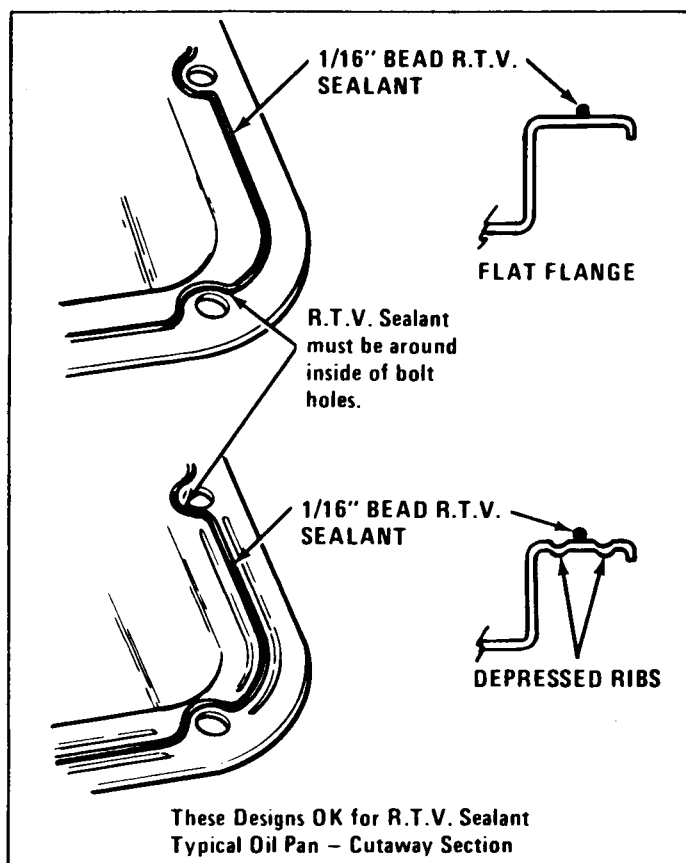

Figure 11

R.T.V. Silicone sealant should be used on oil pans that have a flat flange or a flange with depressed stiffening ribs. However, use of R.T.V. sealant on the side cover should be restricted to the flat flange pan design (Figure 11).

When you use the cork gasket on oil pans with the flat flanges, exercise great care in the torque procedure.



Technical Service Information

Beginning September, 1981, THM 125 transaxles were assembled with a new part called an oil weir. The oil weir is located in the rear of the case (See Figure 12), and is used to retain more lube flow around the differential Assy.

The extra lubrication was to help eliminate wear patterns in the final drive carrier and on the side gears (See Figure 13).

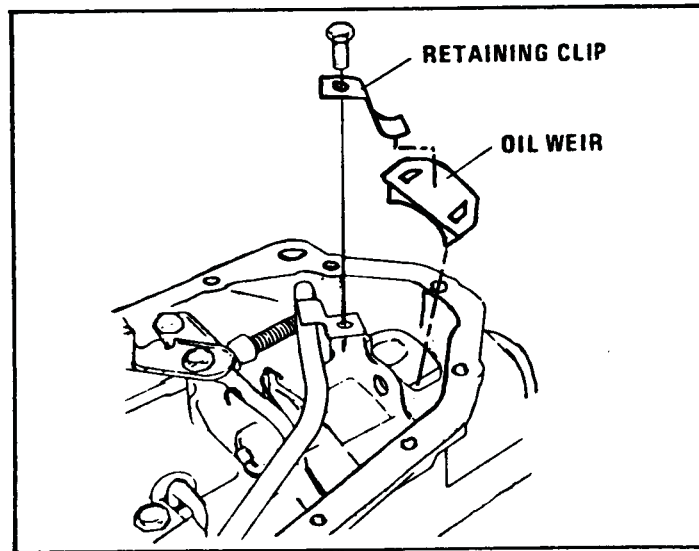

Figure 12

When the final drive carrier would wear it would first show up as an oil leak at the right hand axle seal. The final drive carrier was also later changed to a hardened surface (Identified by its blackened color), to help eliminate wear in this area.

If you should encounter a transaxle without an oil weir during a rebuilt, "ALWAYS" install a new one.

Oil Weir	8637836
Retaining Clip	8637837

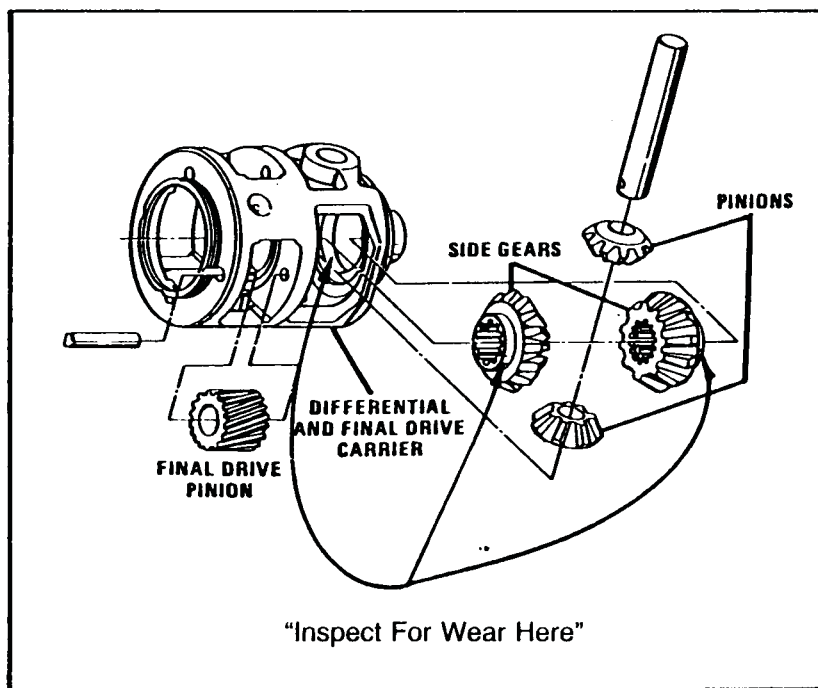

Figure 13



Technical Service Information

Beginning October, 1983, a new larger thrust bearing assembly (Final Drive Sun Gear to Differential Carrier) went into production in the 1984 model THM 125/125C transaxle, using the 2.84 final drive ratio.

The difference between the two thrust bearing assemblies is the outer diameter size. Also the final drive carrier bearing surface is machined larger to accept the larger outer diameter bearing. See figure 14 for comparison of the bearings.

The two thrust bearings are not interchangeable and damage to the final drive could result if the bearings are mixed.

The larger thrust bearing assembly, part number 8646254, was previously used on only the 3.06 and 3.33 final drive assemblies, but is now used on all models.

Thrust Bearing (2 $\frac{1}{8}$ " Diameter)	8646254
Thrust Bearing (2" Diameter)	8628962

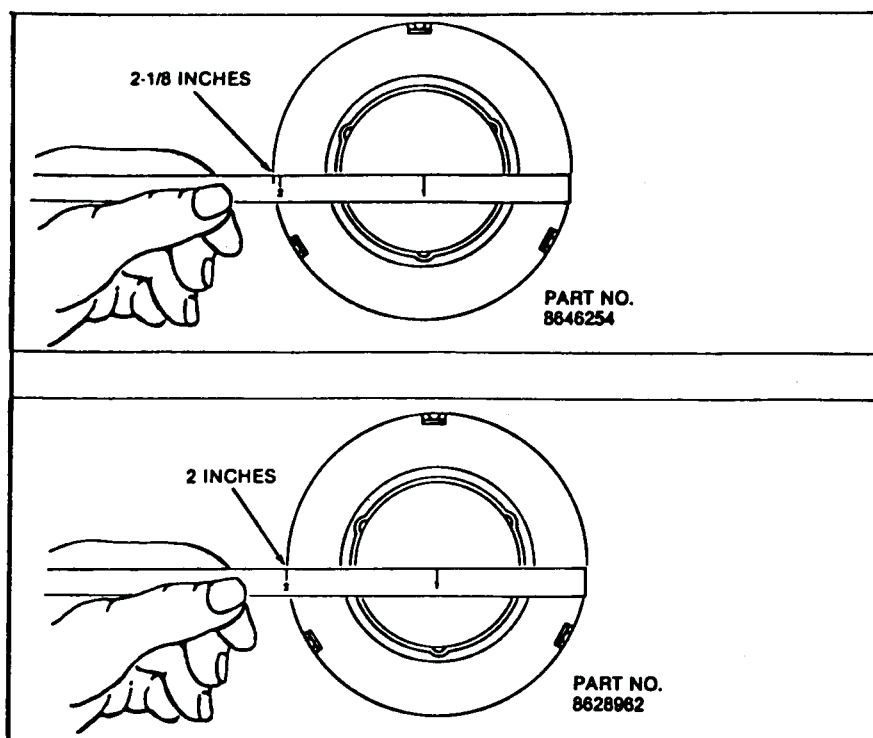

Figure 14



Driven Sprocket Sleeve

When diagnosing a THM 125 transaxle for lack of drive, slipping shifts, or erratic shifts, be sure to check the driven sprocket support for wear as shown in figure 15.

This wear pattern, if present, is caused by the bearing sleeve on the outside hub of the driven sprocket moving off and wearing into the driven sprocket support. As this wear condition reaches an advanced state the oil feed passages in the driven sprocket support are exposed, allowing an oil pressure leak.

The bearing sleeve on the driven sprocket may, after causing the indicated wear pattern (Groove), move back to the proper location and appear to be normal. Consequently, if this condition is present, be certain to check both the driven sprocket and driven sprocket support as shown in Figure 15.

If the above condition exists, replace the driven sprocket, driven sprocket support, and any other affected parts. Be sure also to check the direct and forward clutch packs, as well as the intermediate band for wear.

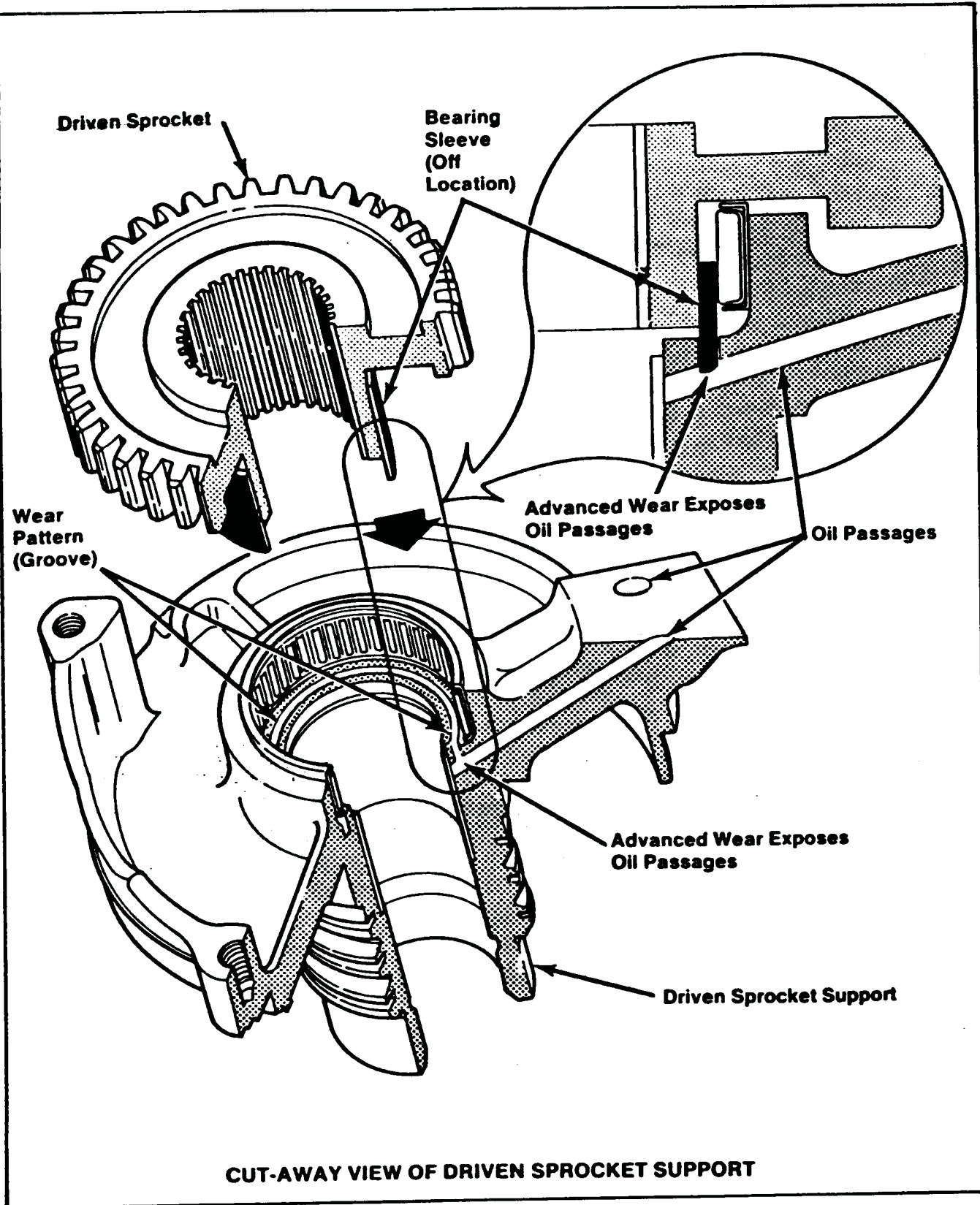

ProCarManuals.com

CUT-AWAY VIEW OF DRIVEN SPROCKET SUPPORT

Figure 15



Technical Service Information

There were several changes on the 3rd accumulator check valve, and only one of which works properly.

The "Only" 3rd accumulator check valve to be used is shown as the 3rd design in Figure 16, and is available under OEM part number 8643964. Install the new conical valve spring onto the valve (Small end first), and install the assembly into the case bore (Figure 16).

If you find a 3rd accumulator check valve like the ones shown in Figure 17, discard them and replace with the 3rd design (8643964).

If this valve is leaking the result will be a burnt intermediate band and burnt direct clutch.

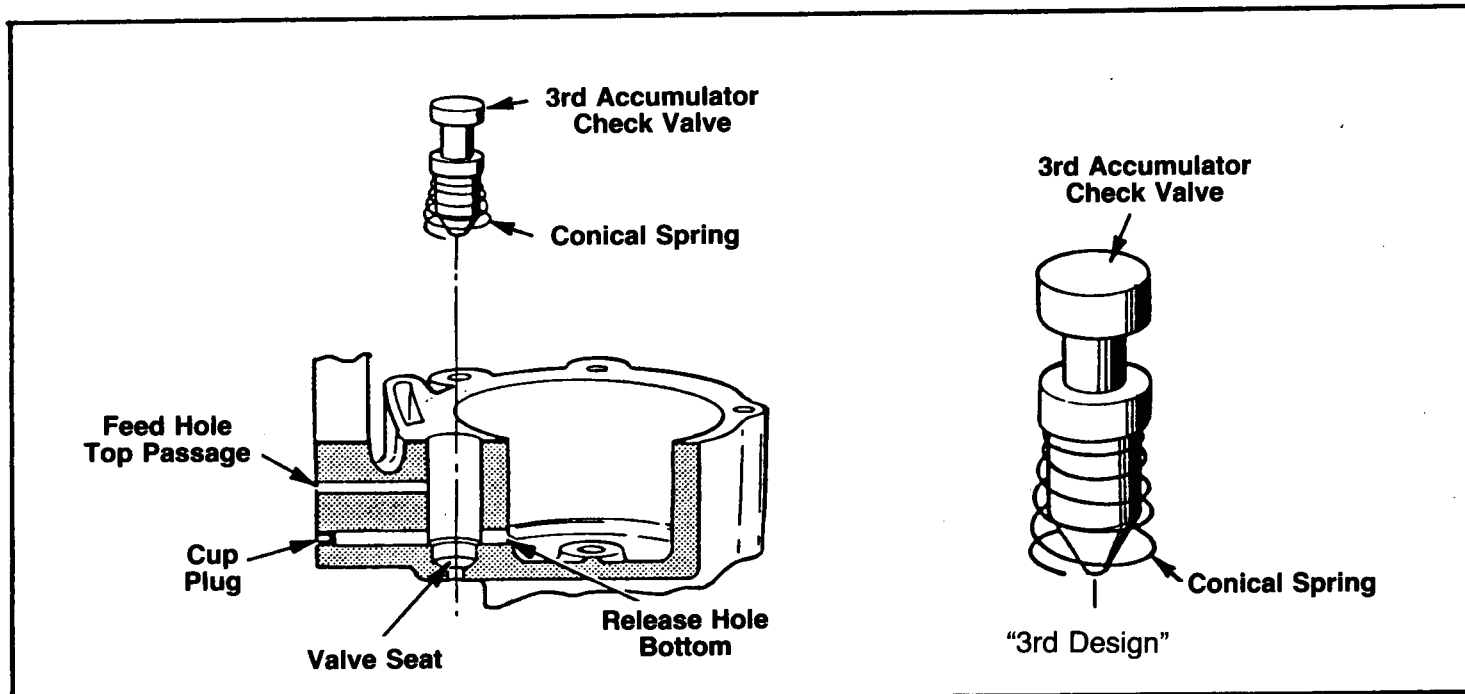

Figure 16

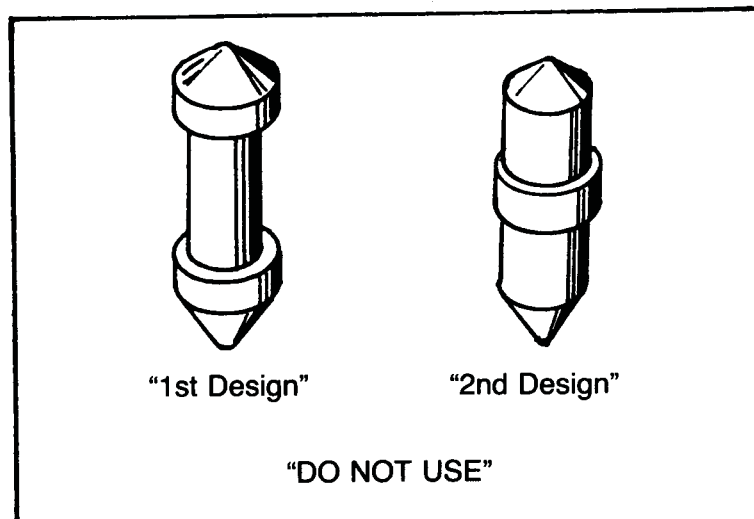

Figure 17

Beginning mid-June, 1981, all THM 125 transaxles were built with a new design band anchor plug. The new design band anchor plug has a tab which holds the part in place. (See Figure 18).

Transaxles built with the past design band anchor plug required a staking operation to hold the part in place (See Figure 19). This staking operation is not required with the new design band anchor plug as it is held in place by the reverse oil pipe. The new design band anchor plug is available under OEM part number 8637640.

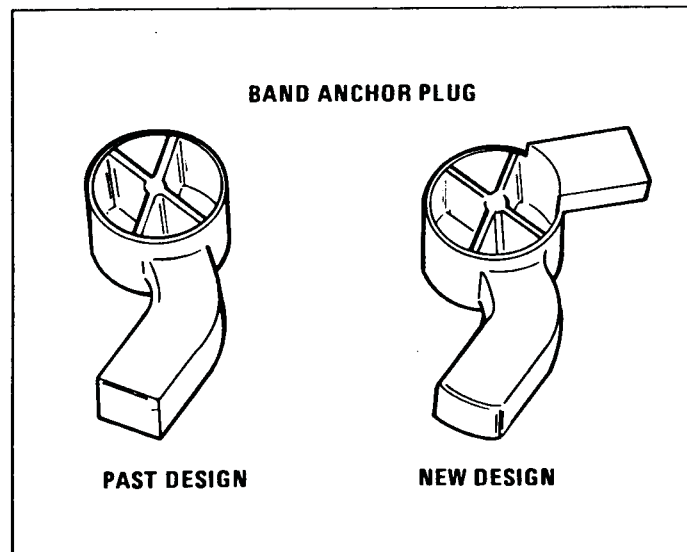

Figure 18

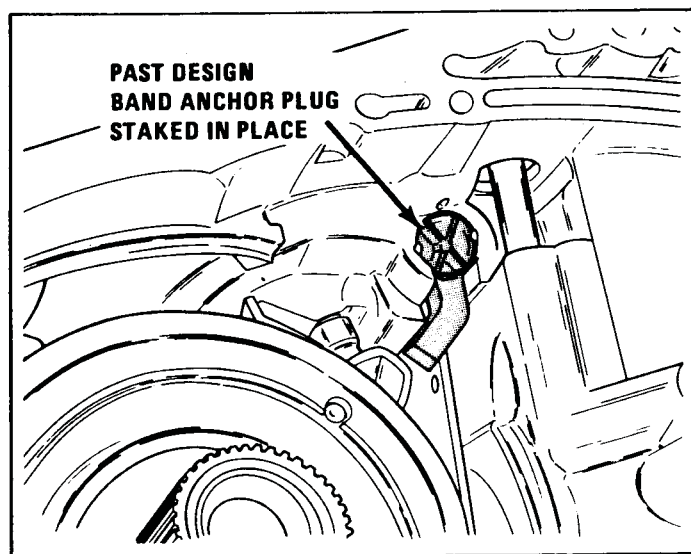

Figure 19

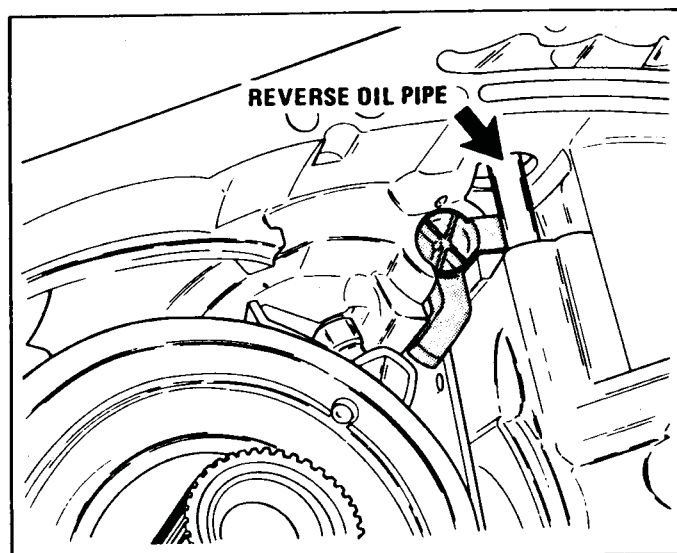

Figure 20

When diagnosing any THM 125/125C transaxle for no drive or harsh shift conditions, check the valve body assembly for a worn (Nibbled) or missing pressure regulator valve retaining pin. See Figure 21 for retaining pin location.

If the pressure regulator valve retaining pin is worn (Nibbled), or missing, use a 1/4" drift punch and stake the pressure regulator valve retaining pin hole part of the way shut. See inset Figure 21. Stake the pin hole only enough to hold the new retaining pin in place after assembly.

After assembling the pressure regulator valve train, retain the valve train with a new solid steel retaining pin, OEM part number 112496. The new pin must be inserted from, and flush with, the machined surface of the valve body assembly.

This new solid steel retaining pin should be used in "ALL" THM 125/125C transaxles, in the pressure regulator line up.

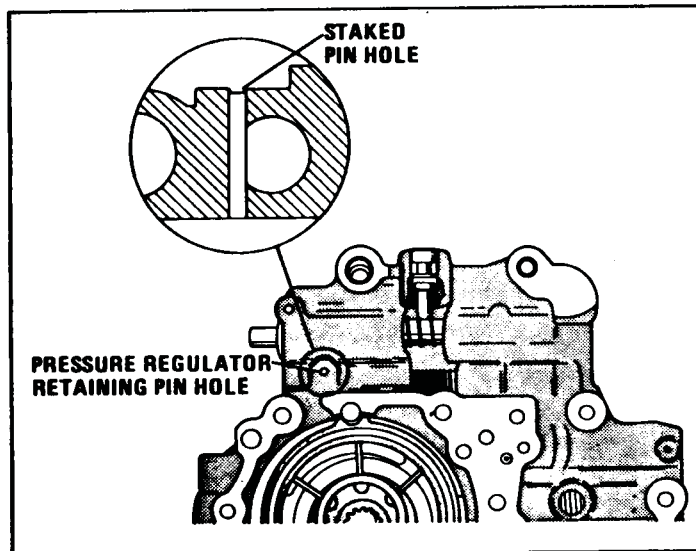

Figure 21

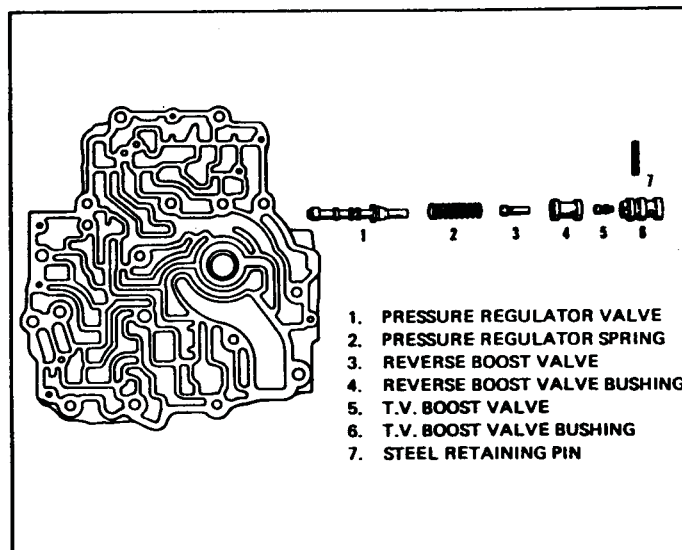

Figure 22



Beginning in late April, 1981, THM 125 transaxles were built with a new design case and case cover. This design change relocated the case to case cover bolts from inside the bell housing to the case cover area to eliminate a possible oil leak location. (Figure 23)

When installing the new design bolts, thread sealer must be used on the threads, and the bolts torqued to 15 ft.-lbs.

The new design parts and the past design parts are not interchangeable.

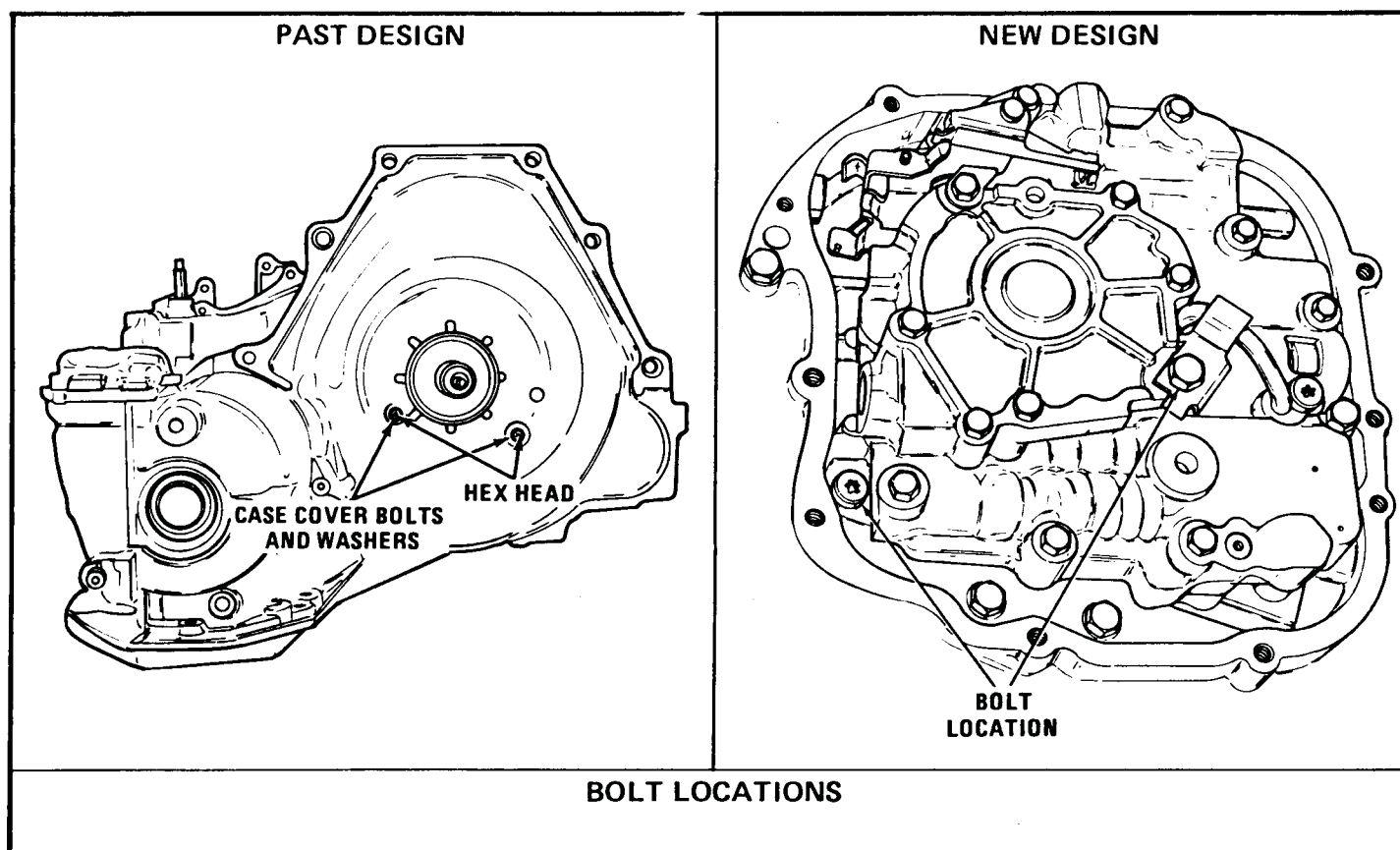

Figure 23

AUTOMATIC TRANSMISSION SERVICE GROUP



Beginning in model year 1982, the torque converter clutch was introduced in the THM 125. With the addition of the clutch in the torque converter, the converter housing had to be made thicker to accommodate the converter clutch.

This required a new design turbine shaft, and oil pump drive shaft. The splines of the new design turbine shaft are 5.1mm (.200") longer than the non lock-up, and has an added "O" ring groove (See Figure 24). The new design oil pump drive shaft is 23.7mm (.933") longer than the non lock-up and has 15 teeth on the oil pump spline instead of the past design 20 teeth (See Figure 25). The spline change was implemented to provide more load bearing surface on the teeth to help eliminate stripping of the rotor splines.

There is also available on the aftermarket, an oil pump drive shaft that is the same length as the non lock-up, but has 15 teeth on the oil pump spline for improved durability of the pump rotor on the early model THM 125.

The converter housing seal was also redesigned at the same time, with an additional metal flange pressed into the back of the seal. The additional flange helps retain the garter spring during installation. The new design converter housing seal can be identified by part number 8637420 on the seal. The past design converter housing seal will either have no identification number or will have part number 8631158 on the seal (See Figure 26).

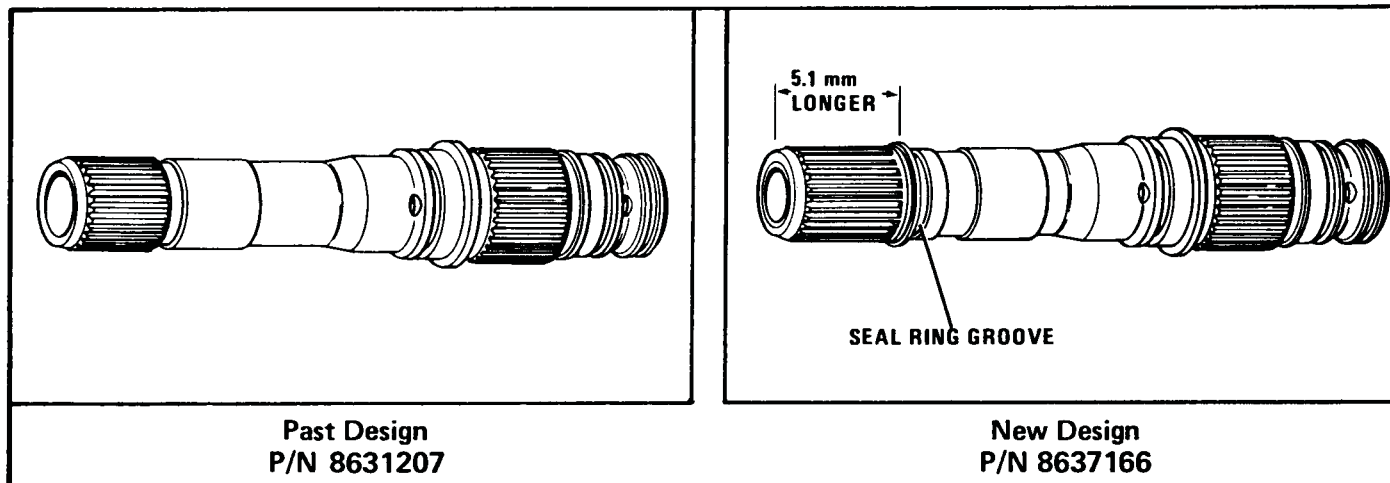

Figure 24

AUTOMATIC TRANSMISSION SERVICE GROUP

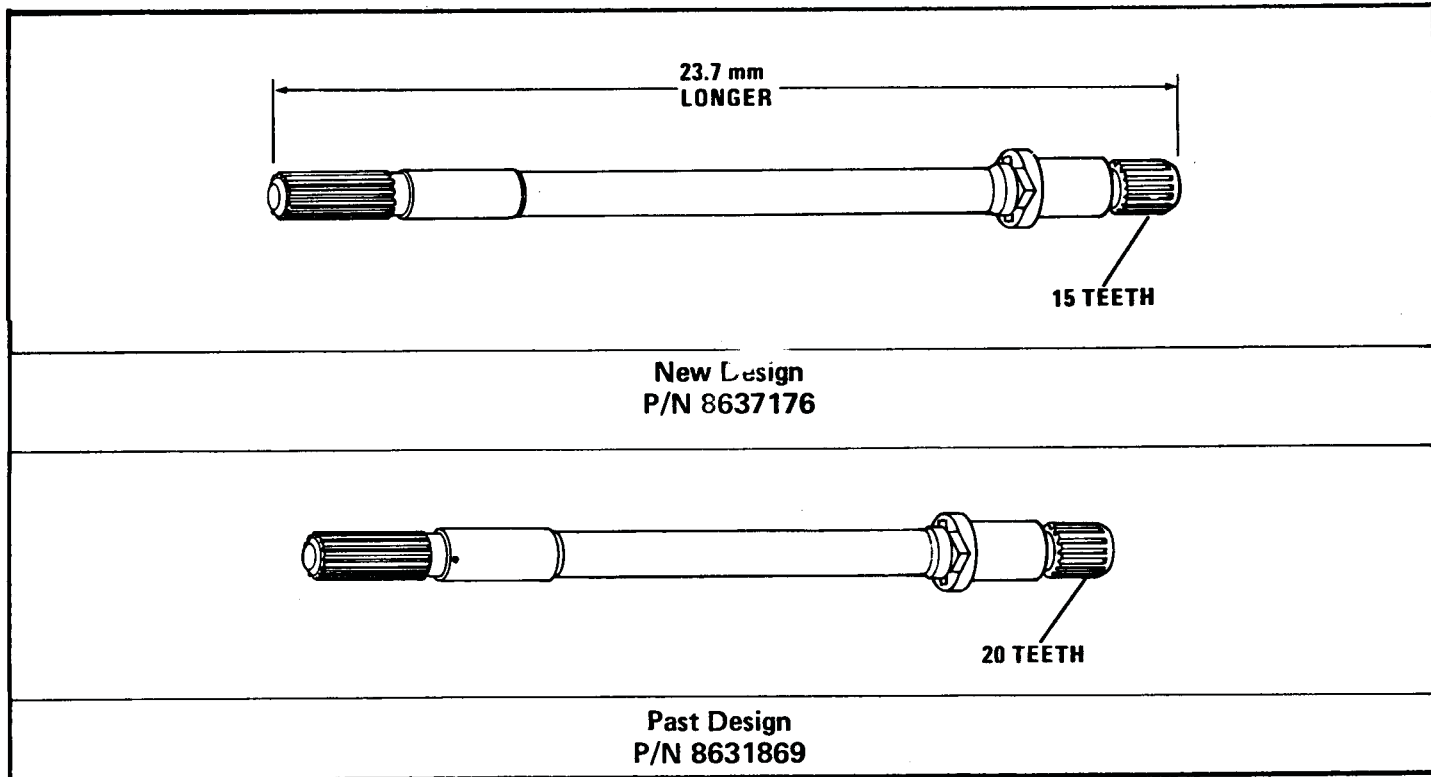

Figure 25

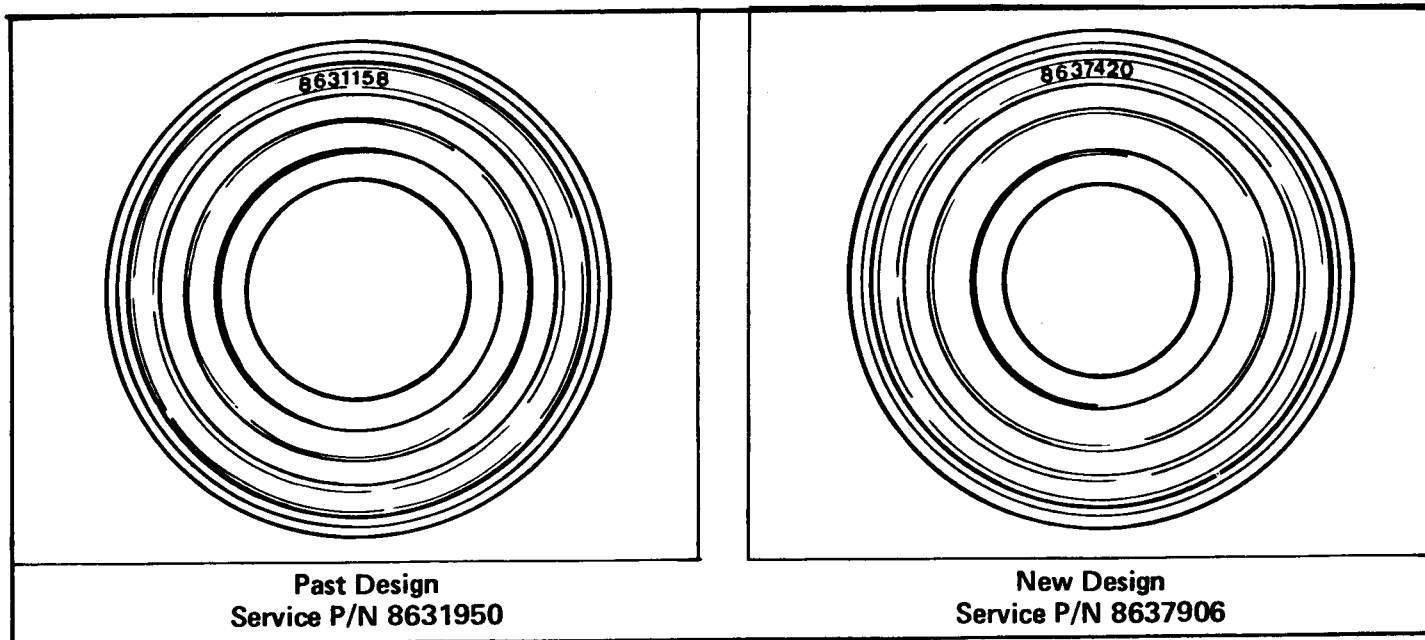

Figure 26



Some 1982 and 1983 THM 125C transaxles may experience a torque converter shudder condition immediately following engagement of the torque converter clutch.

The cause could be an incorrectly machined seal groove on the turbine shaft. A step in the bottom corners of the seal groove (Figure 27) will prevent the solid Teflon seal from contacting the side wall of the groove and will not seal properly. If this condition is found, replace both the turbine shaft and the turbine shaft seals.

You should replace scarf cut seals with the solid Teflon seals, and install the solid seals in all three locations that are shown in Figure 27. Follow service manual procedures for installing and sizing the new seals.

Solid Turbine Shaft Seals (1980-1981)	8631987
Solid Turbine Shaft Seals (1982-Up)	8631968

ProCarManuals.com

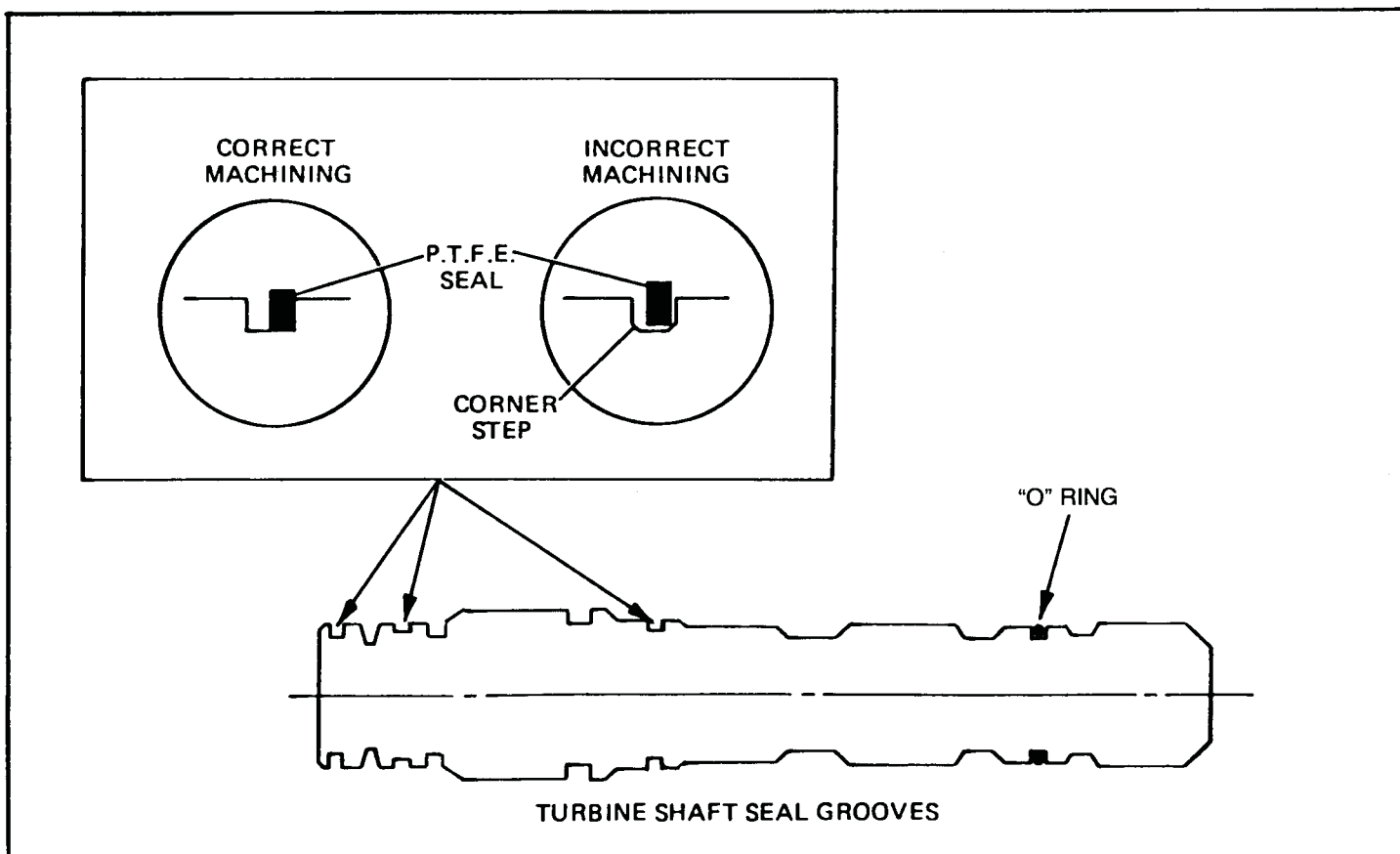

Figure 27

AUTOMATIC TRANSMISSION SERVICE GROUP



Beginning mid-August, 1981, THM 125C transaxles were built with a new (Wider) design intermediate band assembly (P/N 8637623), and a new designed direct clutch housing assembly (P/N 8637976). See Figure 28. The new design direct clutch housing has a wider surface area on the drum outside diameter to accommodate the new wider intermediate band assembly, and improve intermediate band durability.

The narrow design direct clutch housing can only be used with the narrow design intermediate band. Do not use the wide intermediate band assembly on the narrow design direct clutch housing assembly or interference will destroy the intermediate band.

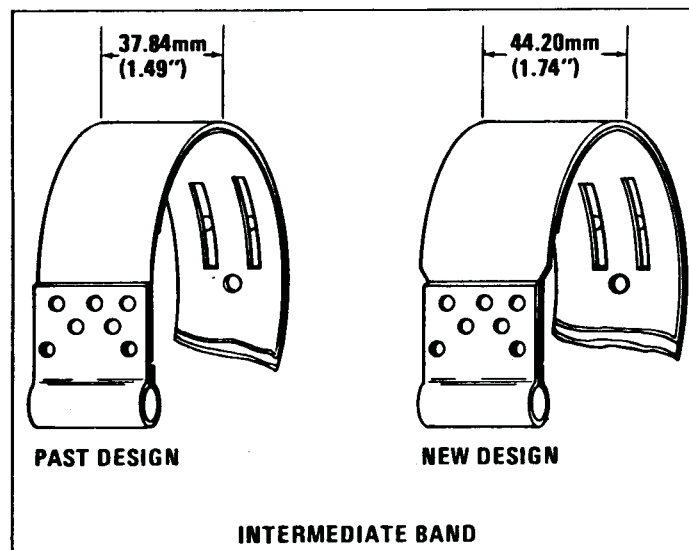

Figure 28

AUTOMATIC TRANSMISSION SERVICE GROUP

Running changes were made in the forward clutch housing assembly, to produce a more desirable neutral to drive engagement feel. These changes were accomplished in two steps.

2nd Design—Beginning July, 1981:

- 1) The forward clutch piston was redesigned, eliminating the apply ring (See Figure 30).
- 2) The backing plate was made selective to control clutch pack clearance.

Thickness	I.D. Code
.236" - .240"	1
.208" - .212"	2
.181" - .185"	3

NOTE: Piston travel should be .040" - .060"

3rd Design—Beginning September, 1981:

- 1) The forward clutch feed orifice was made smaller, (Figure 30, Item 3) and an oil displacement insert was added (Figure 30, Item 4).
- 2) The check ball capsule was eliminated and two exhaust holes were added to the new forward clutch piston (Figure 30, Item 6). When the piston is applied the exhaust holes will seal against the wave plate.

NOTE: None of the above parts are interchangeable.

The forward clutch housing on the THM 125/125C is prone to cracking, and we have shown in Figure 29 where to inspect for cracks.

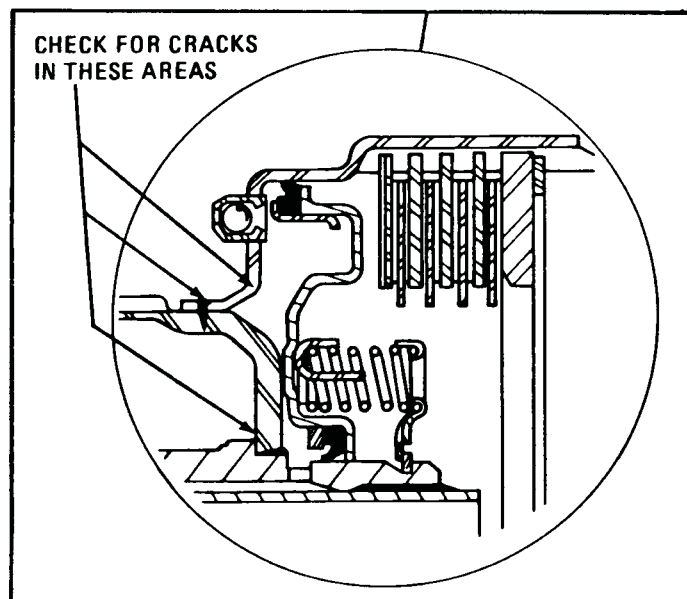

Figure 29

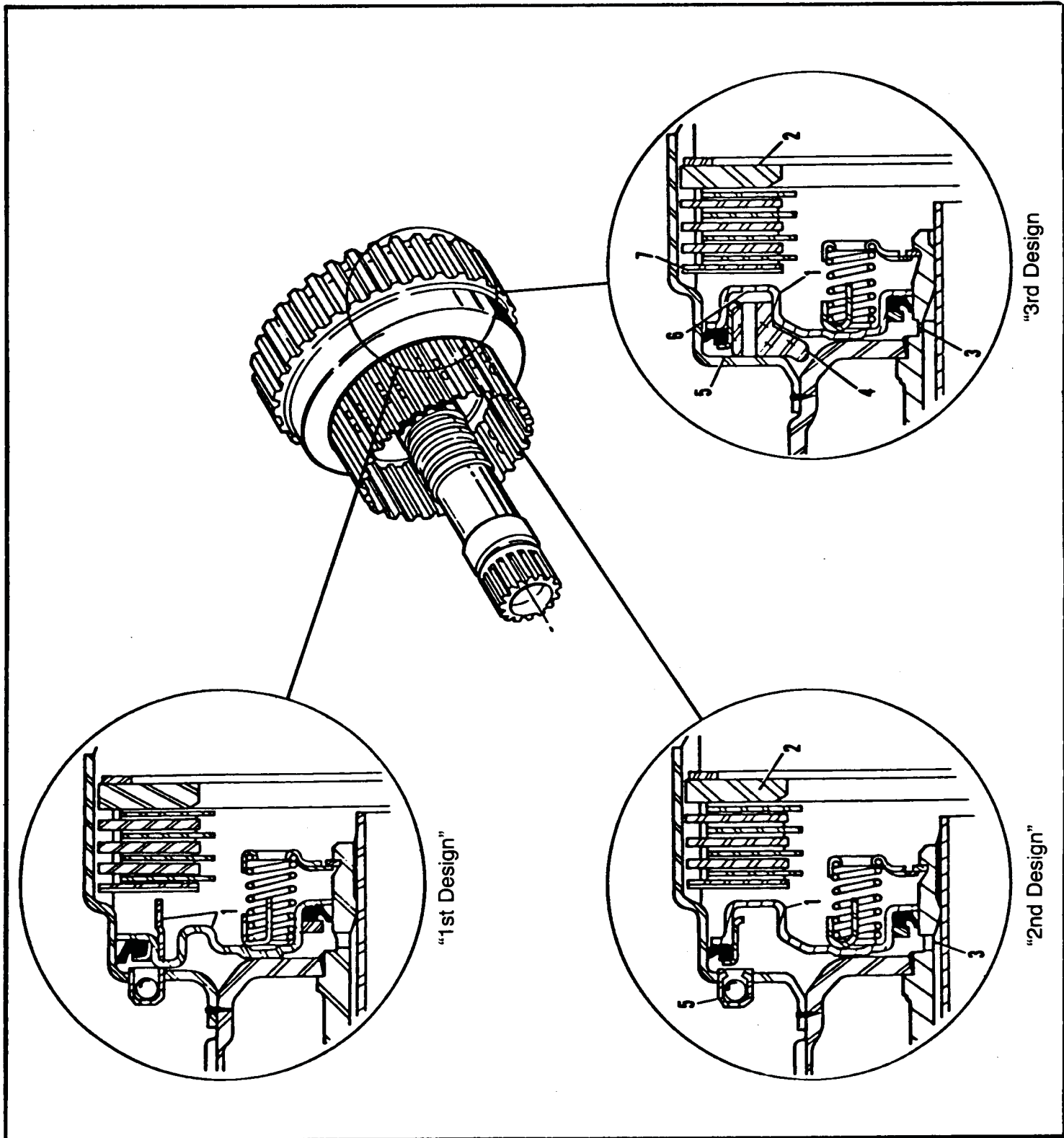

Figure 30



Front Seal Pop-out

Some THM 125/125C transaxles may experience an oil leak from the bell housing area, which is due to the front converter seal coming out of the case bore. This condition results from an oil pressure build up behind the converter seal, which forces the converter seal out of its seat in the case bore.

When servicing any THM 125/125C transaxle for this condition, it is recommended that an oil drainback hole be drilled into the converter seal bore of the transaxle case (See Figure 31).

CAUTION: Proper location is important in drilling the hole.

Drill from the case cover side, a 3/16" minimum diameter hole, at the 11 or 10-o'clock position. It is very important that the hole be drilled at this location so as not to lose our lube oil to the drive sprocket support bearing. Position the drill at about a 45 degree angle when drilling (See Figure 32). The hole must be drilled through so that it exits inside the radius of the seal bore diameter. See Figure 31. Use care not to touch the seal bore diameter with the drill bit.

Later model cases had a hole cast in this location and need not be drilled.

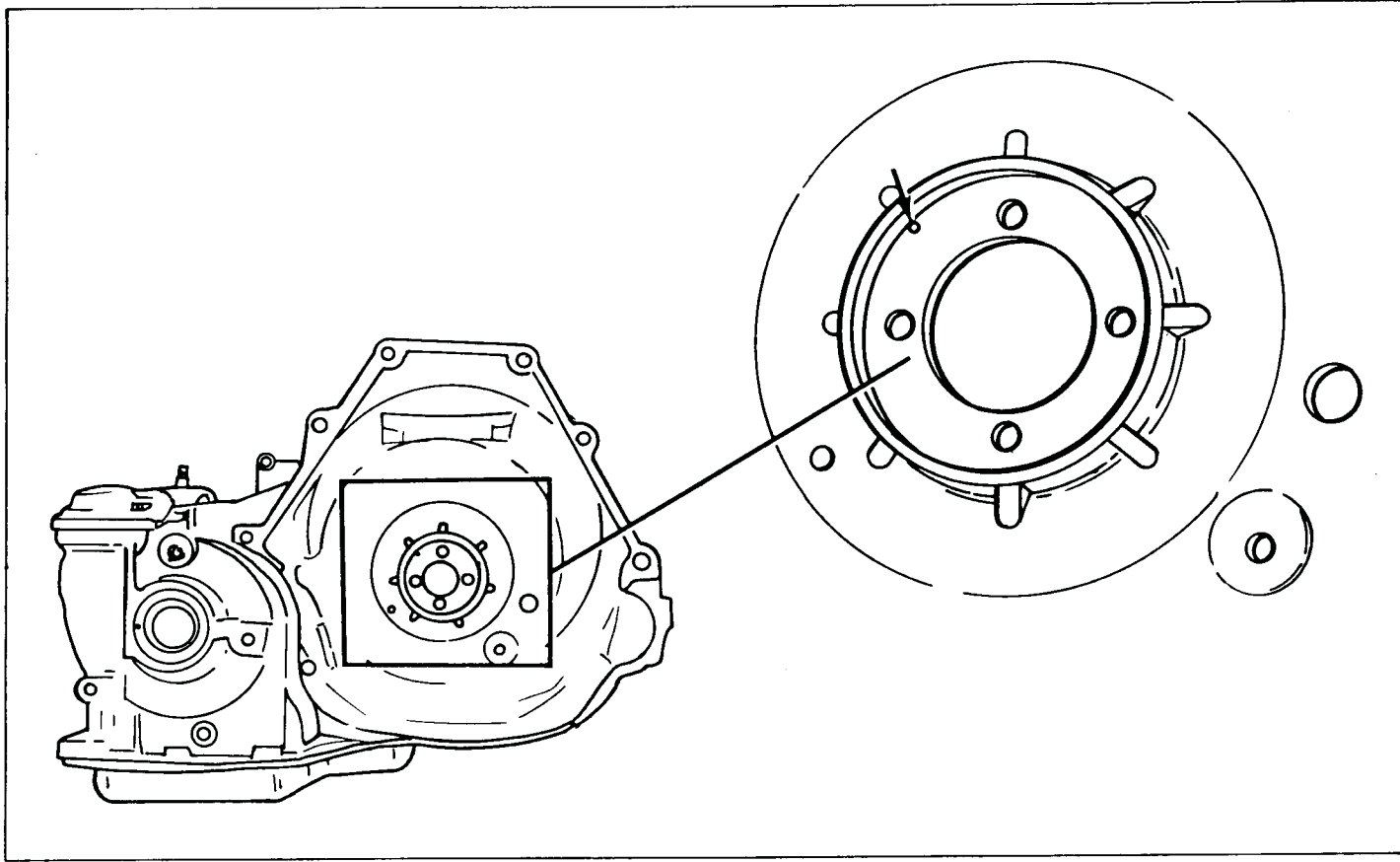

Figure 31

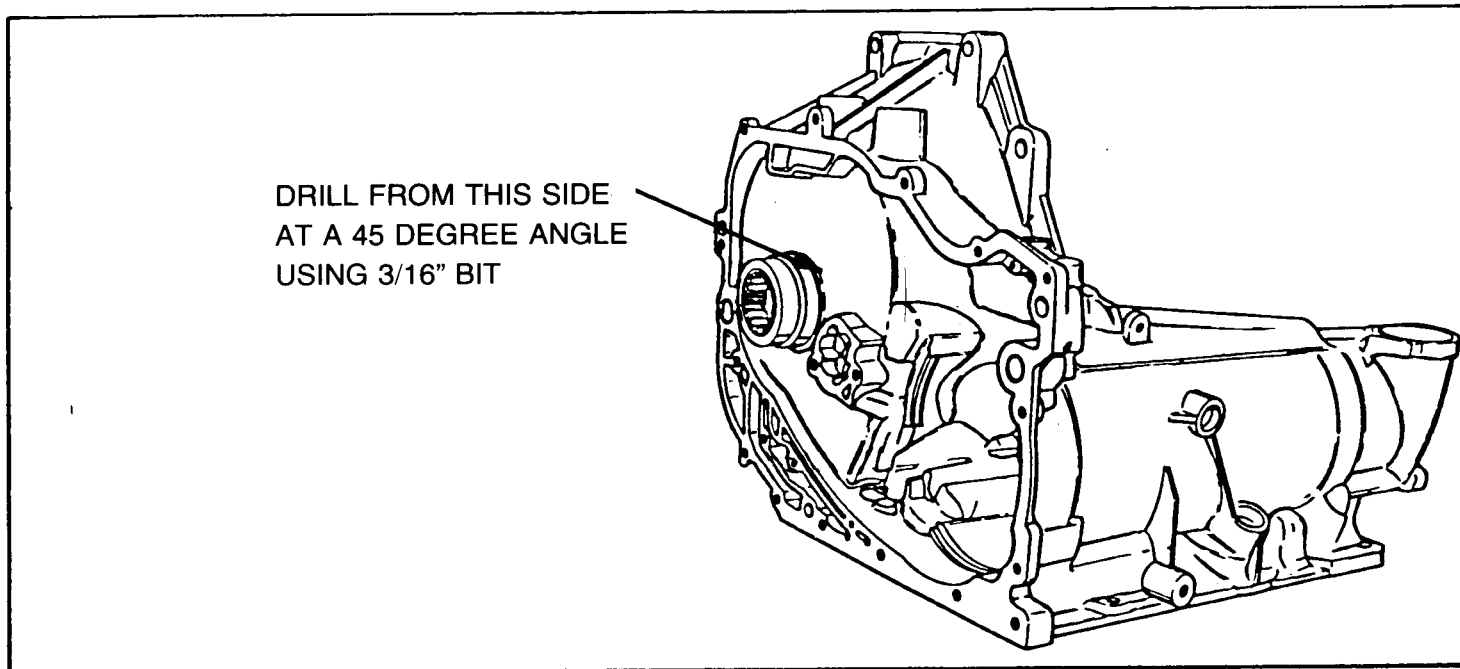

Figure 32



Beginning mid-April, 1983, service parts were made available to service the oil pump rotor and slide in the valve body and oil pump assembly, on all THM 125/125C transaxles.

We have provided you with the part numbers to order replacement parts needed. See Figure 34. Also listed below in Figure 33 are parts previously released to service the oil pump assembly.

ILL. NO.	PART NAME	PART NUMBER
18	THM 125 Oil Pump Drive Shaft (1980-81)	8631869
18	THM 125C Oil Pump Drive Shaft (1982-83)	8637777
344	Pump Cover Sleeve	8631288
345	Slide Pivot Pin	8628273
346-347	Pump Slide Seal Package	8631947
351	Pump Vane Ring	8631279
352	Pump Vane	8631280
354	Pump Drive Shaft Bearing Assembly	8631277
357	Pump Drive Shaft Seal	8637569
359	Pump Priming Spring	8631717

- 18 SHAFT, OIL PUMP DRIVE
- 301 BODY, OIL PUMP AND CONTROL VALVE
- 344 SLEEVE, AUXILIARY VALVE BODY
- 345 PIN, SLIDE PIVOT
- 346 RING, OIL SEAL - SLIDE TO COVER
- 347 SEAL, "O" RING (SLIDE)
- 348 SLIDE, PUMP
- 349 SUPPORT, PUMP SLIDE SEAL
- 350 SEAL, PUMP SLIDE

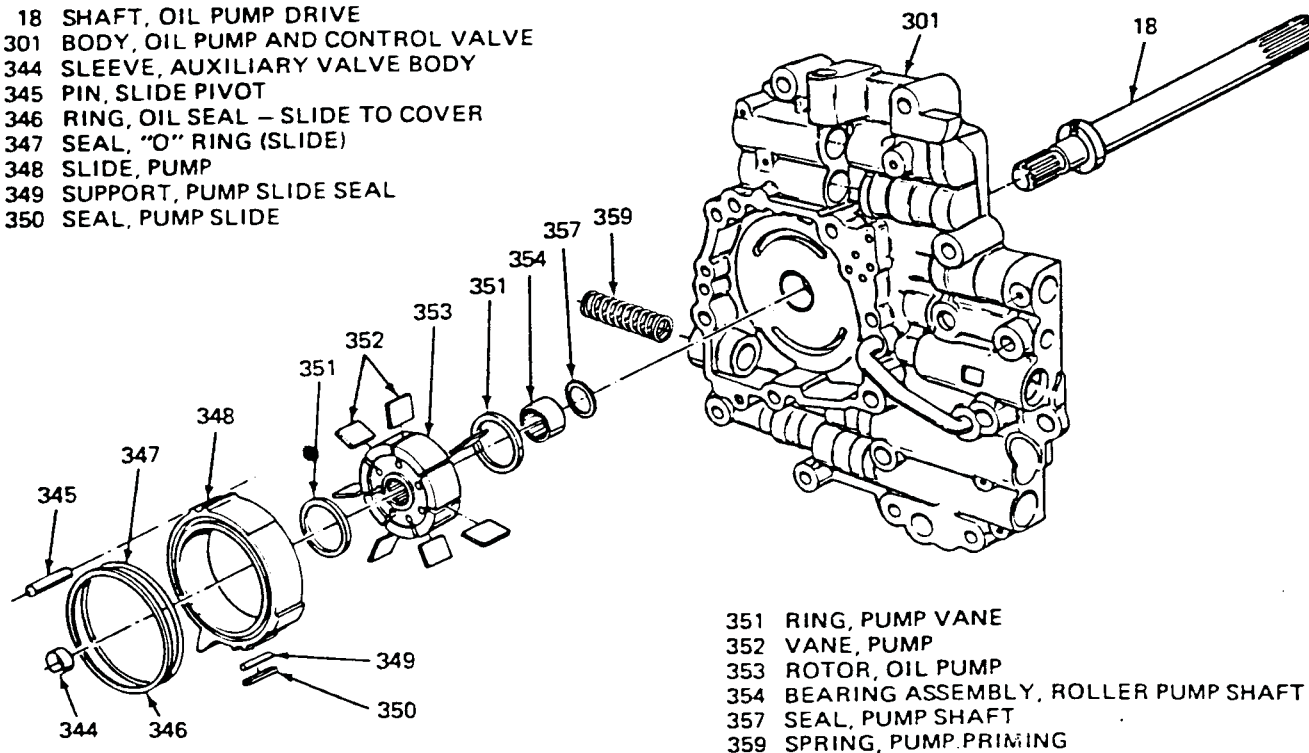

- 351 RING, PUMP VANE
- 352 VANE, PUMP
- 353 ROTOR, OIL PUMP
- 354 BEARING ASSEMBLY, ROLLER PUMP SHAFT
- 357 SEAL, PUMP SHAFT
- 359 SPRING, PUMP PRIMING

Figure 33

AUTOMATIC TRANSMISSION SERVICE GROUP



1980-1981 THM 125 SELECTIVE PUMP ROTOR (20 TOOTH)

<u>PART NUMBER</u>	<u>THICKNESS (MM)</u>	<u>THICKNESS (IN.)</u>
8631495	17.943 - 17.955	0.7065 - 0.7069
8631496	17.956 - 17.968	0.7070 - 0.7074
8631497	17.969 - 17.981	0.7075 - 0.7079
8631514	17.982 - 17.994	0.7080 - 0.7084
8631515	17.995 - 18.008	0.7085 - 0.7089

1982-1983 THM 125C SELECTIVE PUMP ROTOR (15 TOOTH)

<u>PART NUMBER</u>	<u>THICKNESS (MM)</u>	<u>THICKNESS (IN.)</u>
8637768	17.917 - 17.929	0.7055 - 0.7059
8637769	17.930 - 17.942	0.7060 - 0.7064
8637178	17.943 - 17.955	0.7065 - 0.7069
8637179	17.956 - 17.968	0.7070 - 0.7074
8637180	17.969 - 17.981	0.7075 - 0.7079

1980-1983 THM 125/125C SELECTIVE PUMP SLIDE

<u>PART NUMBER</u>	<u>THICKNESS (MM)</u>	<u>THICKNESS (IN.)</u>
8631800	17.955 - 17.967	0.7070 - 0.7074
8631801	17.968 - 17.980	0.7075 - 0.7079
8631802	17.981 - 17.993	0.7080 - 0.7084
8631803	17.994 - 18.006	0.7085 - 0.7089
8631804	18.007 - 18.020	0.7090 - 0.7094

Figure 34



Technical Service Information

Since the start of production, 1982, the THM 125C transaxle has had several changes in the auxiliary valve body cover. The changes were implemented to eliminate a light throttle converter clutch shudder condition.

The 1982 auxiliary valve body cover originally had a cast slot in it (1st Design).

The auxiliary valve body cover was changed mid model year to that of having an orificed cup plug in place of the slot (2nd Design).

Approximately May 1982, the auxiliary valve valve body cover was changed to omit the orifice in the cup plug (3rd Design).

In late 1982, the auxiliary valve body cover was changed to a solid cast cover with no cup plug in it (4th Design).

When servicing any THM 125C transaxle, use only the 3rd design or the 4th design auxiliary valve body covers. You can use the 2nd design if you install a solid cup plug.

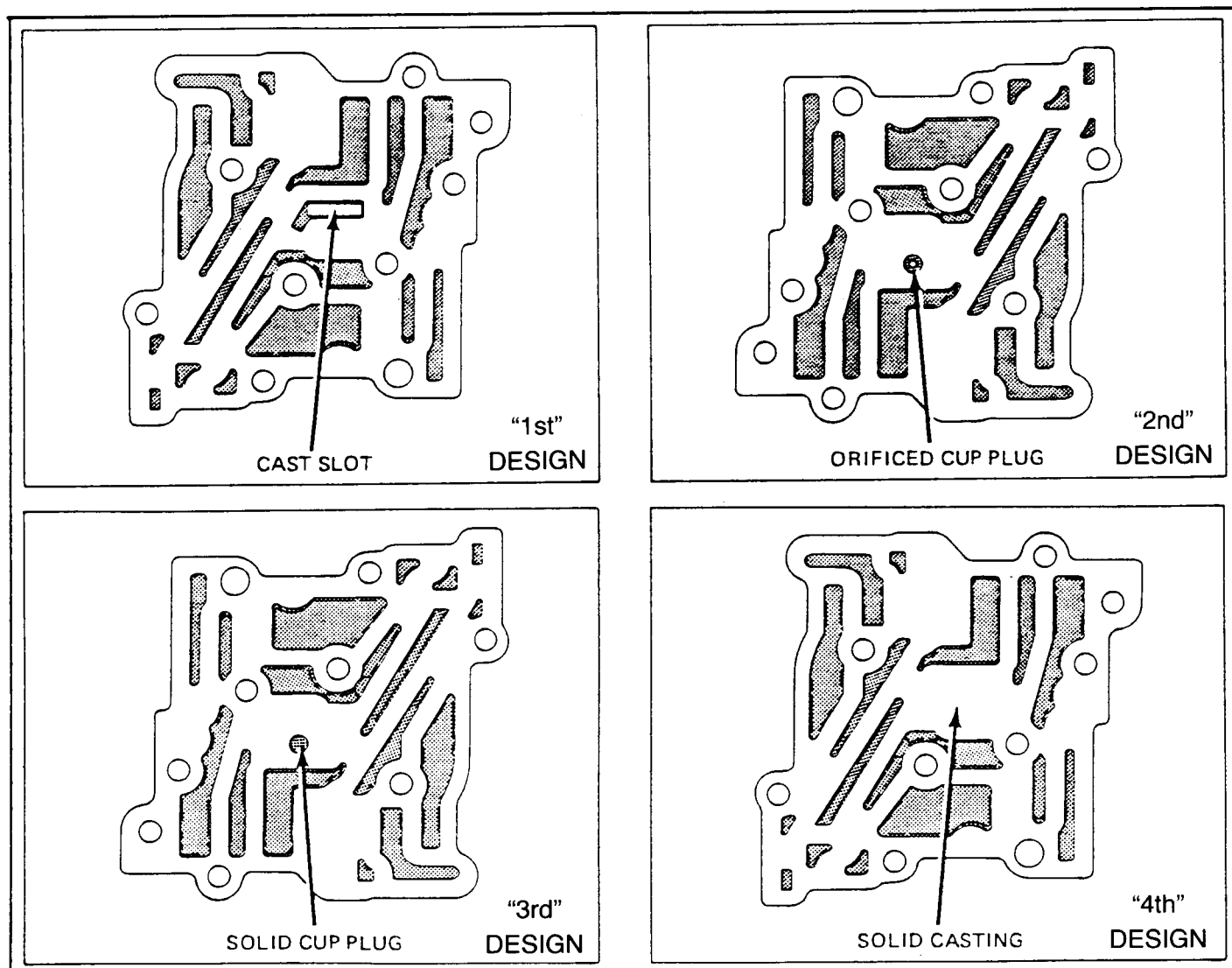

Figure 35



Low-Reverse Piston

Several running changes between September, 1982, and March, 1983, have been made in the low and reverse piston assembly. We have shown all three designs (Figures 36, 37, 38) that occurred in that time period. The low and reverse piston changed again in 1984 models and will be covered later, in the 1984 changes, in this Update Handbook.

2nd DESIGN—Beginning Sept., 1982

- 1) Low and reverse piston redesigned and apply ring eliminated. See Figure 37. This design allowed the lip seal retainer to become separated from the low and reverse piston assembly, creating a no reverse, or neutral to reverse delayed engagement condition. Do not use this type.

3rd DESIGN—Beginning March, 1983

- 1) Low and reverse piston redesigned with a 3rd design lip seal retainer that would not come off, and the addition of an oil displacement insert (See Figure 38). The insert reduces the fill time, and quickens the apply of the low and reverse clutch.

Our recommendation is to use only the 3rd design low and reverse piston, and the oil displacement insert when servicing any THM 125 or THM 125C up through model year 1983.

Low and Reverse Piston (3rd Design)	8653916
Oil Displacement Insert	8643490

AUTOMATIC TRANSMISSION SERVICE GROUP

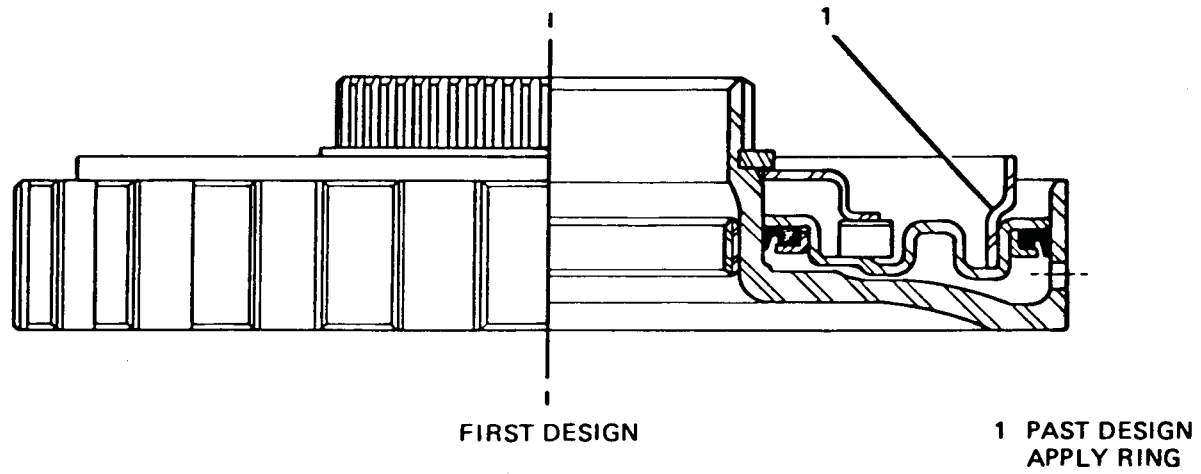

Figure 36

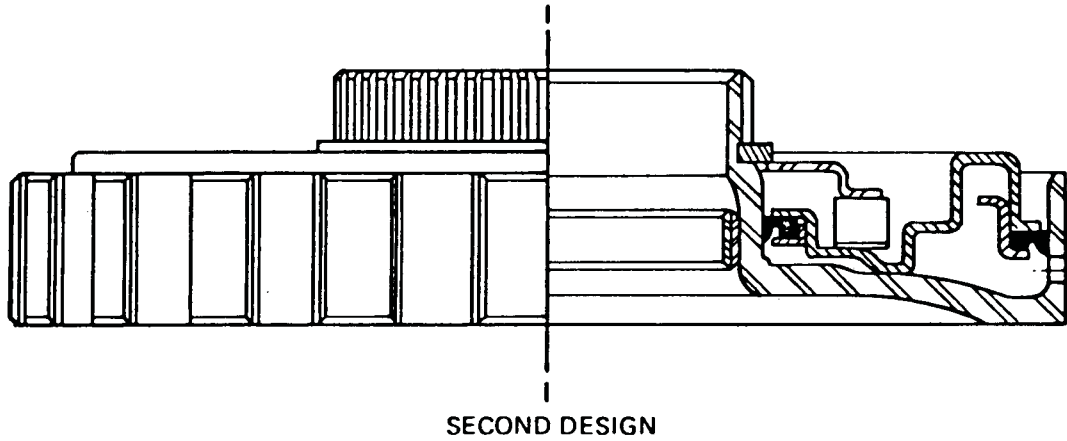

Figure 37

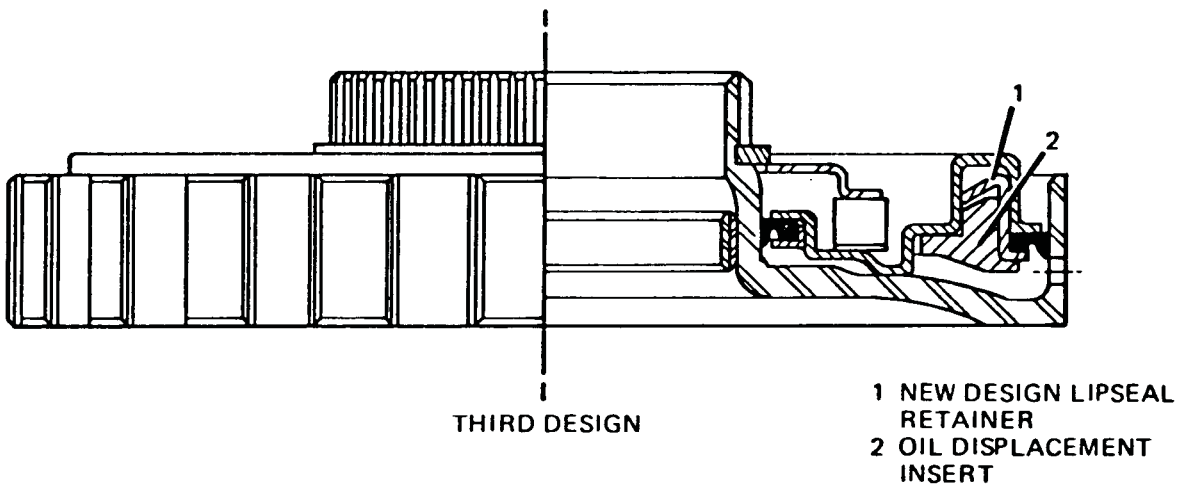

Figure 38



Some 1983 THM 125C transaxles may exhibit a 3-2 coastdown clunk condition that is most noticeable at approximately 15 miles per hour when decelerating. This 3-2 coastdown clunk condition may be caused by a broken intermediate servo cushion spring (Figure 39).

Beginning August, 1983, a new intermediate servo cushion spring went into production on the THM 125C transaxles.

If the intermediate servo cushion spring is cracked, broken, or damaged, replace it with OEM part number 8652057.

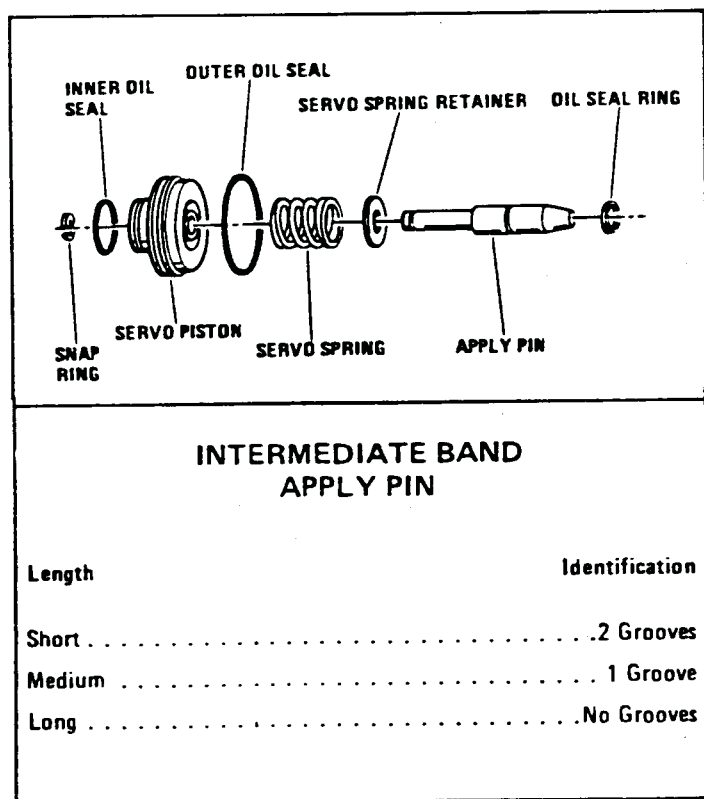

Figure 39

AUTOMATIC TRANSMISSION SERVICE GROUP



Beginning in September, 1983, the THM 125/125C transaxle oil pan and valve body cover changed again. This new oil pan and valve body cover are thicker and have a raised, continuous rib on the flange (See Figure 40). The new oil pan and valve body cover requires a gasket.

“DO NOT” use R.T.V. sealant with the 3rd design oil pan or valve body cover, as oil leaks may result.

Pan, Transaxle Oil (3rd Design)	8643574
Cover, Valve Body (3rd Design)	8643575
Gasket, Transaxle Oil Pan	8643572
Gasket, Valve Body Cover	8631340

ProCarManuals.com

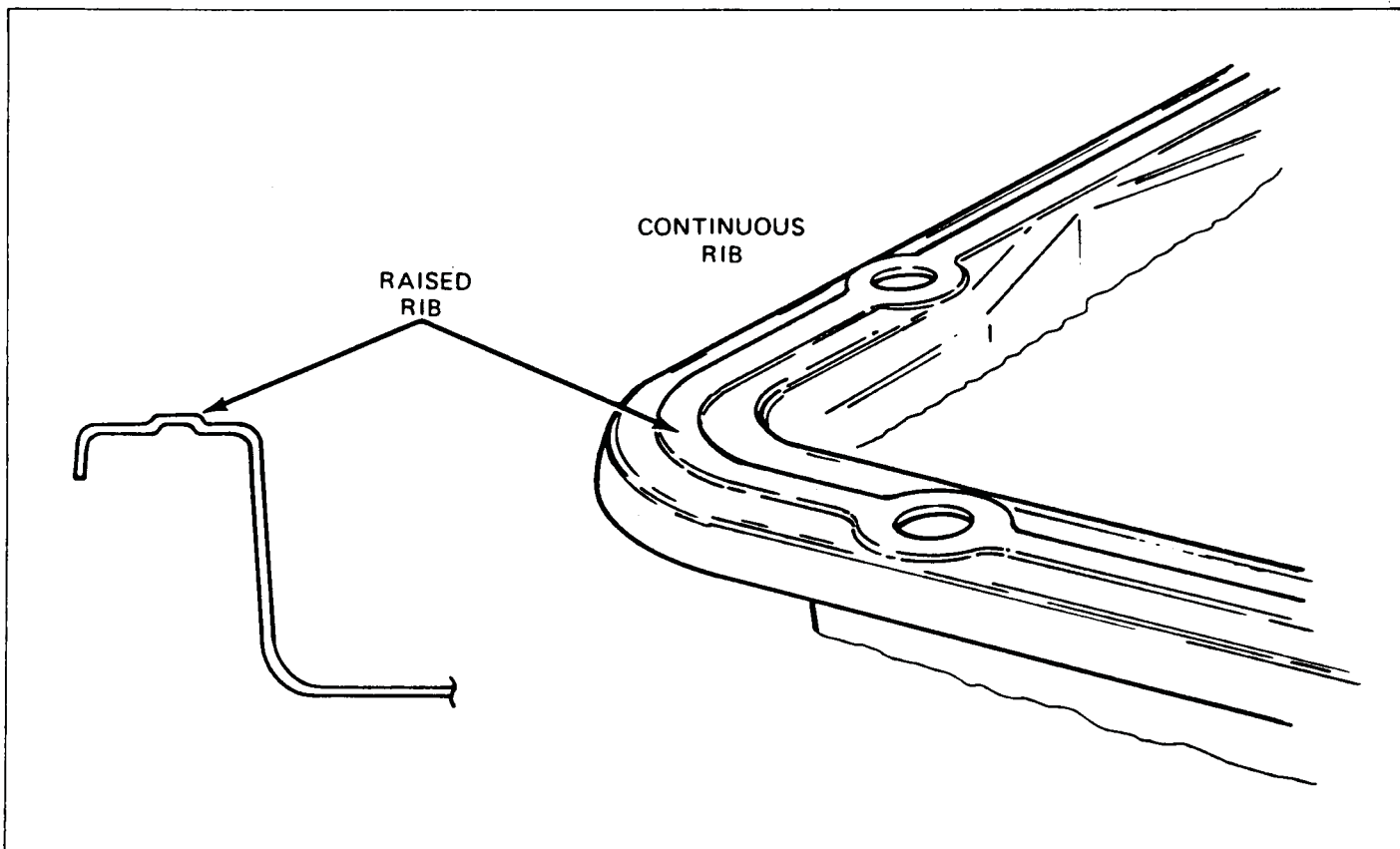

Figure 40

AUTOMATIC TRANSMISSION SERVICE GROUP



Beginning 1984 production of the THM 125/125C transaxles a new transaxle case went into production. The changes to the 1984 THM 125/125C transaxle case are as follows:

CHANGES IN THE 1984 THM 125/125C CASE ASSEMBLY:

- 1) The manual shaft hole was bored larger in diameter to accommodate a larger diameter manual shaft.
- 2) The manual shaft seal bore was made deeper to accommodate a double lip seal.
- 3) The transaxle case casting was modified to accept a neutral start switch.
- 4) The final drive ring gear spacer ring groove was moved toward the final drive to accommodate thicker Low and Reverse clutch plates.

NOTE: The 1984 THM 125/125C transaxle case cannot be used to service any models prior to the 1984 model. The 1983 model or earlier transaxle case cannot be used to service the 1984 125/125C transaxle.



Auxiliary Valve Body

At the start of production for model year 1984, all THM 125C transaxles were built with a new (2nd Design) auxiliary valve body and auxiliary valve body cover gasket. The 2nd design auxiliary valve body does not have an orifice cup plug hole (See Figure 41). The 2nd design auxiliary valve body cover gasket was made out of a new material and has three holes made larger (See Figure 42).

The changes made to the auxiliary valve body and valve body cover gasket eliminated a no torque converter clutch release or no T.C.C. apply condition that resulted from incorrect cup plug, movement of orifice cup plug, or eroding gasket.

The only interchangeable part is the auxiliary valve body cover itself, and always use only the 3rd or 4th design cover if replacement is necessary. See Figure 35 on page 28.

NOTE: The 1st design auxiliary valve body cover gasket must be used with the 1st design auxiliary valve body (See Figure 41, 42).

The 2nd design auxiliary valve body cover gasket must be used with the 2nd design auxiliary valve body (See Figure 41, 42).

The 3rd design auxiliary valve body cover gasket must be used with the 3rd design auxiliary valve body and is discussed in the 1987 changes in this handbook.

THE AUXILIARY VALVE BODY GASKETS ARE **NOT** INTERCHANGEABLE.

Gasket, Auxiliary Valve Body Cover (82-83)	8653947
Gasket, Auxiliary Valve Body Cover (84-86)	8643863
Gasket, Auxiliary Valve Body Cover (1987)	8660795
Cup Plug, Orificed (82-83 Only)	8623796

AUTOMATIC TRANSMISSION SERVICE GROUP

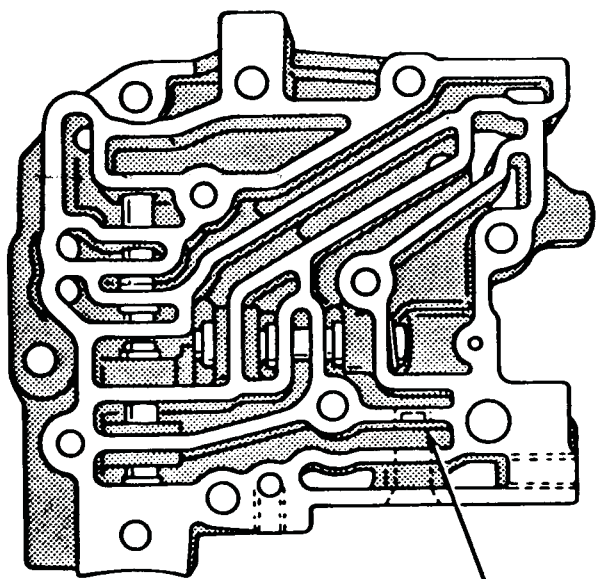

TOP OF ORIFICE
PLUG MUST BE FLUSH
WITH CHANNEL WALL

"1st Design"
Auxiliary Valve Body
(1982-1983)

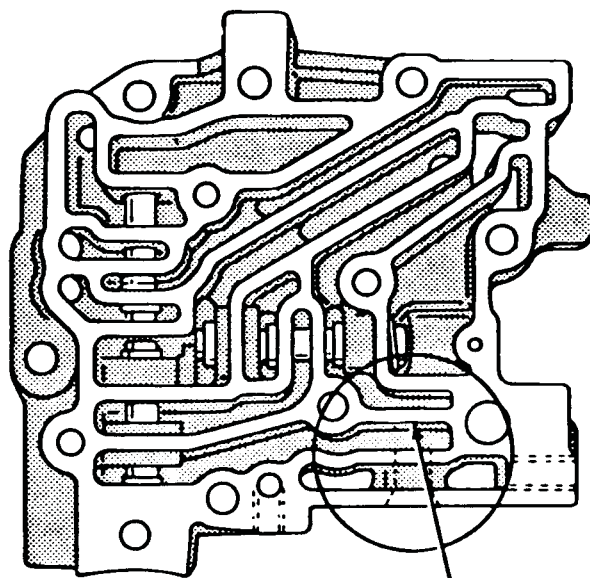

ORIFICE CUP PLUG
AND HOLE OMITTED

"2nd Design"
Auxiliary Valve Body
(1984-1986)

Figure 41

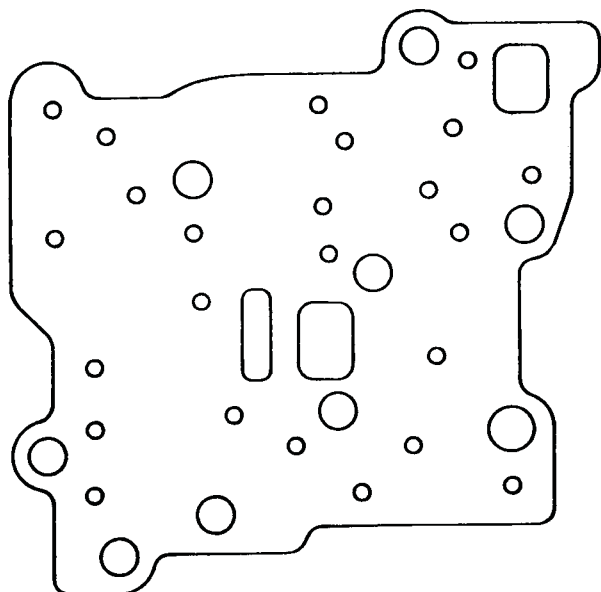

"1st Design"
Auxiliary Gasket
(1982-1983)

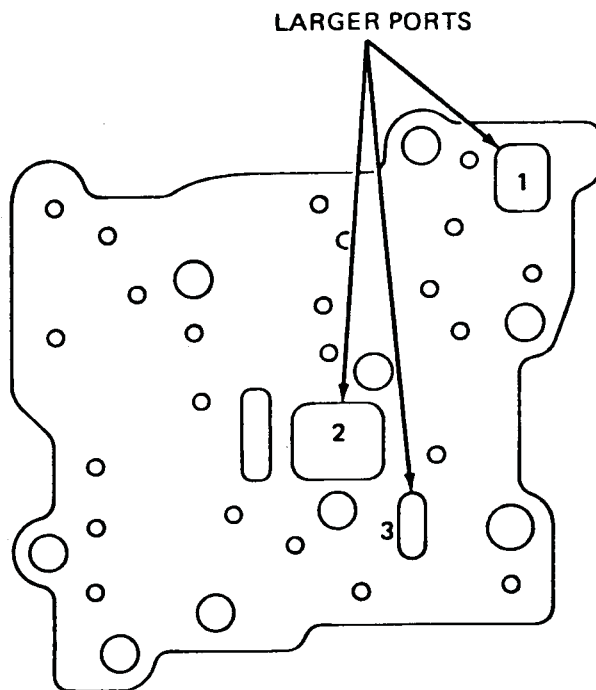

"2nd Design"
Auxiliary Gasket
(1984-1986)

Figure 42



Beginning in model year 1984, the THM 125/125C has 5 L&R friction plates that are .010" thicker, and 5 L&R steel plates that are .010" thicker, for a total of .100". They had to make room for that extra .100" in the L&R clutch pack. They accomplished this by moving the final drive ring gear spacer snap ring groove .050" closer to the final drive and of course this requires a thinner ring gear spacer (See Figure 43). The 1983 ring gear spacer measures 1.344" and can be identified by no notch in tab. The 1984 ring gear spacer measures 1.294" and can be identified by a "V" notch in the tab (See Figure 44).

The other .050" was handled by making the L&R piston .050" thinner. The 1983 piston measures .535" (Total Height) and is identified by a "round" hole in the lip seal retainer on the back of the piston. The 1984 piston measures .485" (Total Height) and is identified by a "square" hole in the lip seal retainer on the back of the piston. This makes the 4th design of the L&R clutch piston. (See Figure 45).

The parts that are **not interchangeable** are, the case assembly, the L&R piston assembly, and the final drive ring gear spacer, and the L&R clutch plates, both lined and steel.

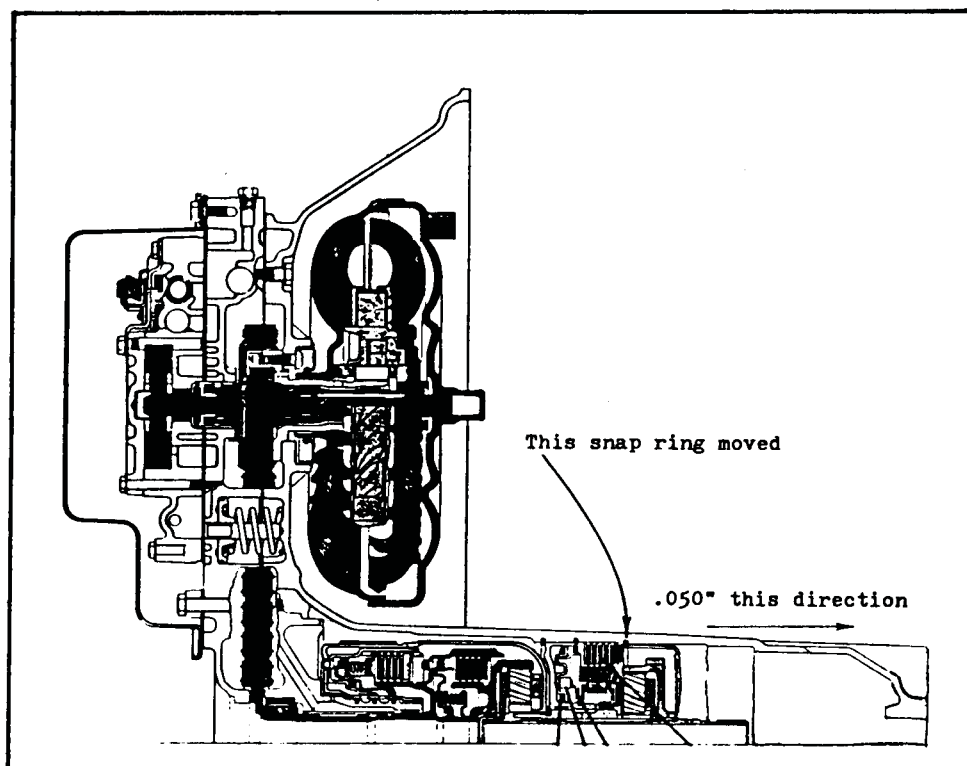

Figure 43

AUTOMATIC TRANSMISSION SERVICE GROUP

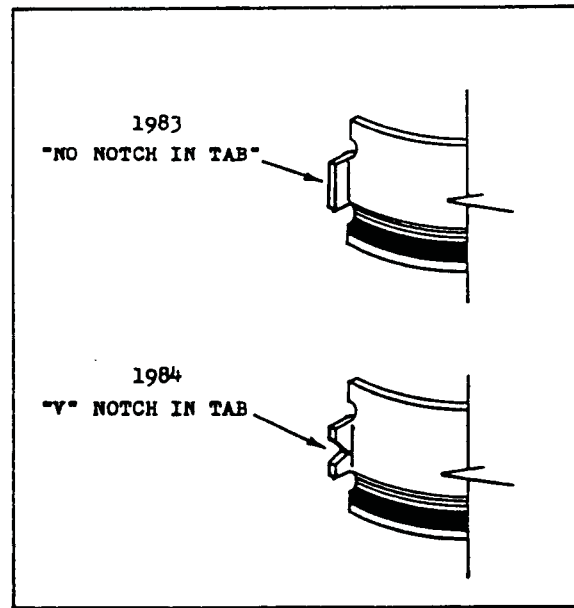

Figure 44

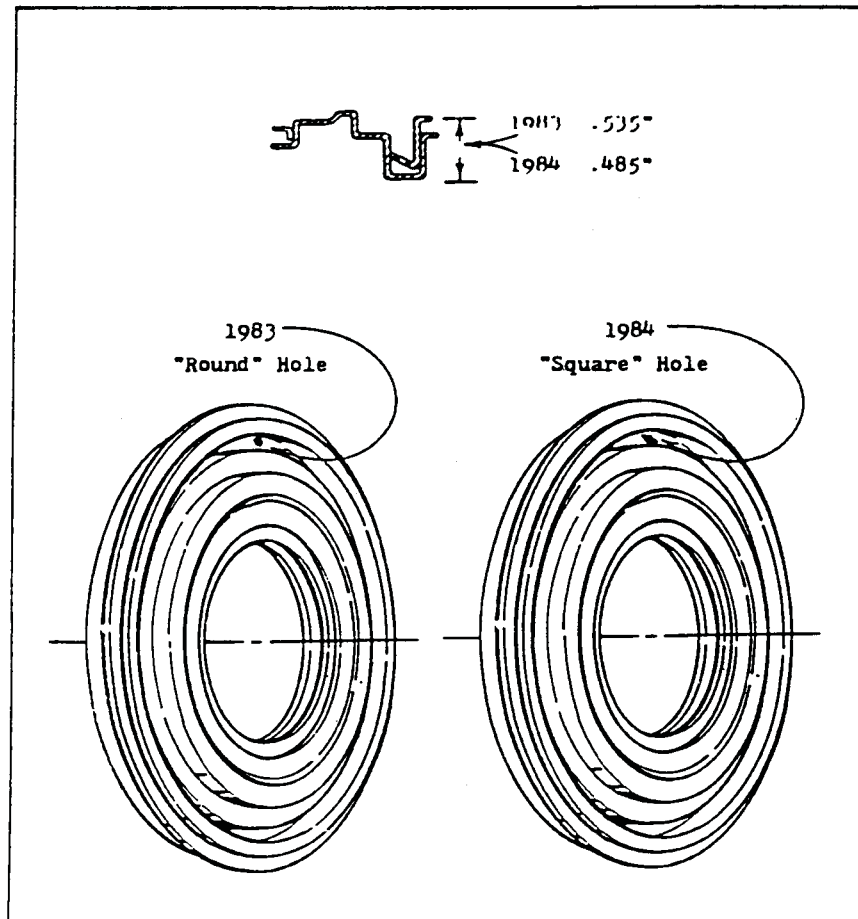

Figure 45

AUTOMATIC TRANSMISSION SERVICE GROUP



Pump Shaft

Beginning in May, 1984, a redesigned oil pump drive shaft and spacer assembly, pump shaft bearing and seal assembly, and valve body and pump assembly went into production on all THM 125/125C transaxles built in the United States.

The redesigned parts provided easier and improved assembly procedures.

The 1st design parts (See Figure 46) are not interchangeable with the 2nd design parts (See Figure 47) for the following reasons.

- 1) The 2nd design oil pump drive shaft and spacer assembly has a thinner spacer and a longer bearing journal diameter to accommodate the 2nd design pump shaft bearing and seal assembly (See Figure 47).
- 2) The 2nd design pump shaft bearing and seal assembly was also made longer to incorporate the seal as part of the bearing assembly (See Figure 47).
- 3) The new valve body and pump assemblies were changed so as to accept the 2nd design oil pump drive shaft and pump shaft bearing and seal assembly.

Shaft, Oil Pump Drive (1st Design)	8643627
Shaft, Oil Pump Drive (2nd Design)	8643764
Bearing Asm, Pump Shaft (1st Design)	8631277
Seal, Pump Shaft (1st Design)	8637569
Bearing and Seal Assembly, (2nd Design)	8643762

AUTOMATIC TRANSMISSION SERVICE GROUP

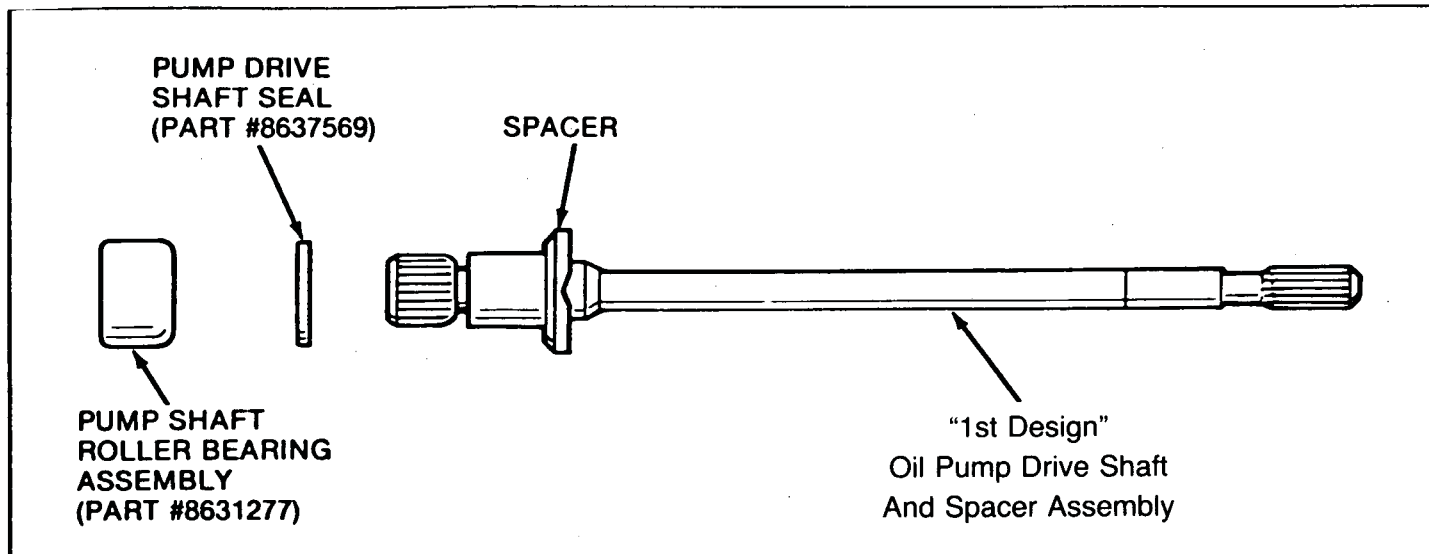

Figure 46

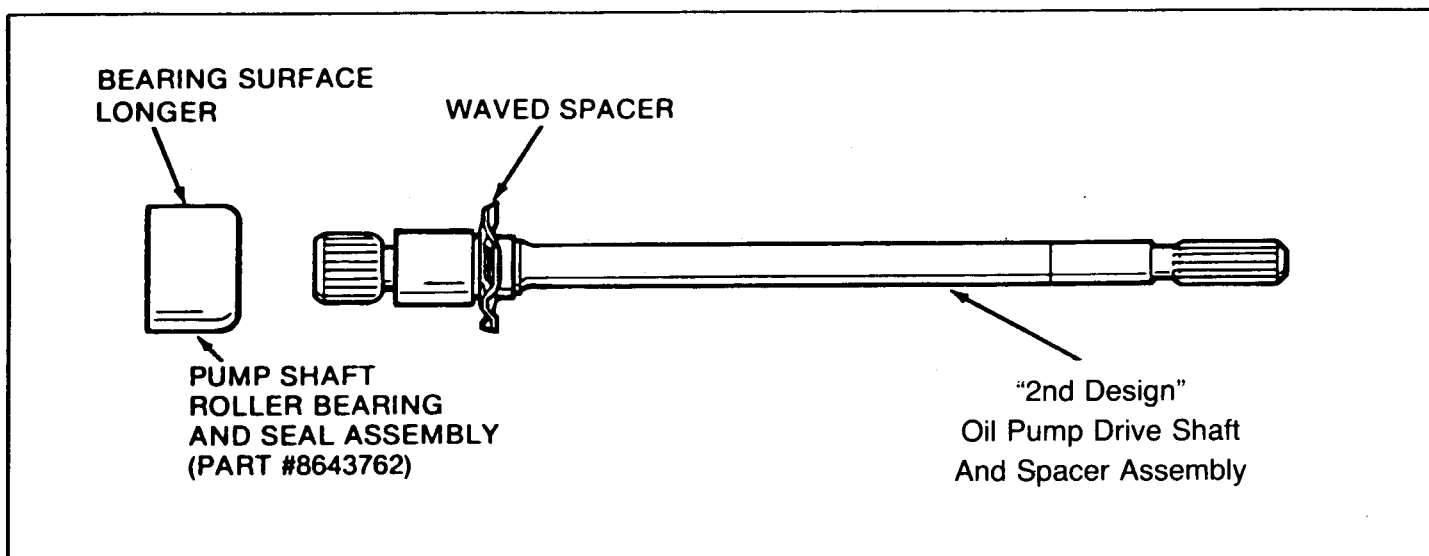

Figure 47

AUTOMATIC TRANSMISSION SERVICE GROUP



Beginning of production 1984, the THM 125/125C transaxle was produced with a $\frac{1}{8}$ " wider drive link assembly (Chain) and $\frac{1}{8}$ " wider drive and driven sprockets, for improved chain durability.

These parts are not interchangeable with the 1983 and earlier model THM 125/125C transaxles.

- Link assembly, Drive (80-83) 8643337 or 8643338
- Link Assembly, Drive (84-87) 8646116 or 8646117

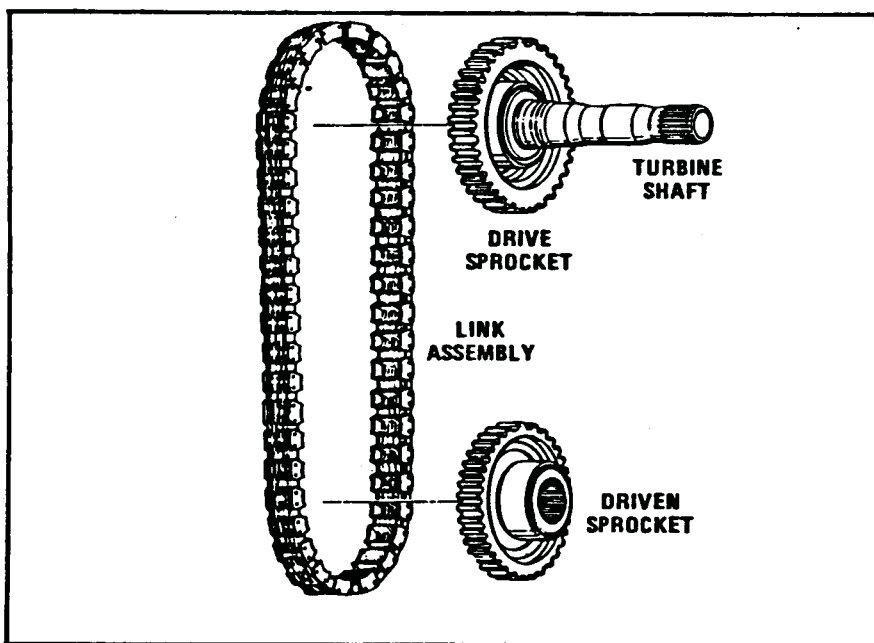

Figure 48

AUTOMATIC TRANSMISSION SERVICE GROUP



When checking the Drive Chain for possible wear on the THM 125/125C transaxle, use the following procedure.

- 1) Midway between the sprockets and at right angles to the chain, push the slack of the chain up until finger tight (Figure 49).
- 2) Lay a ruler on the face of the case and line up the inch mark with the outside edge of the drive chain (Figure 49).
- 3) Push down in the same manner until the slack is finger tight, while holding the ruler down on the case face in the same position that you started (Figure 49). If this dimension exceeds $15/16$ inch, replace the drive chain.

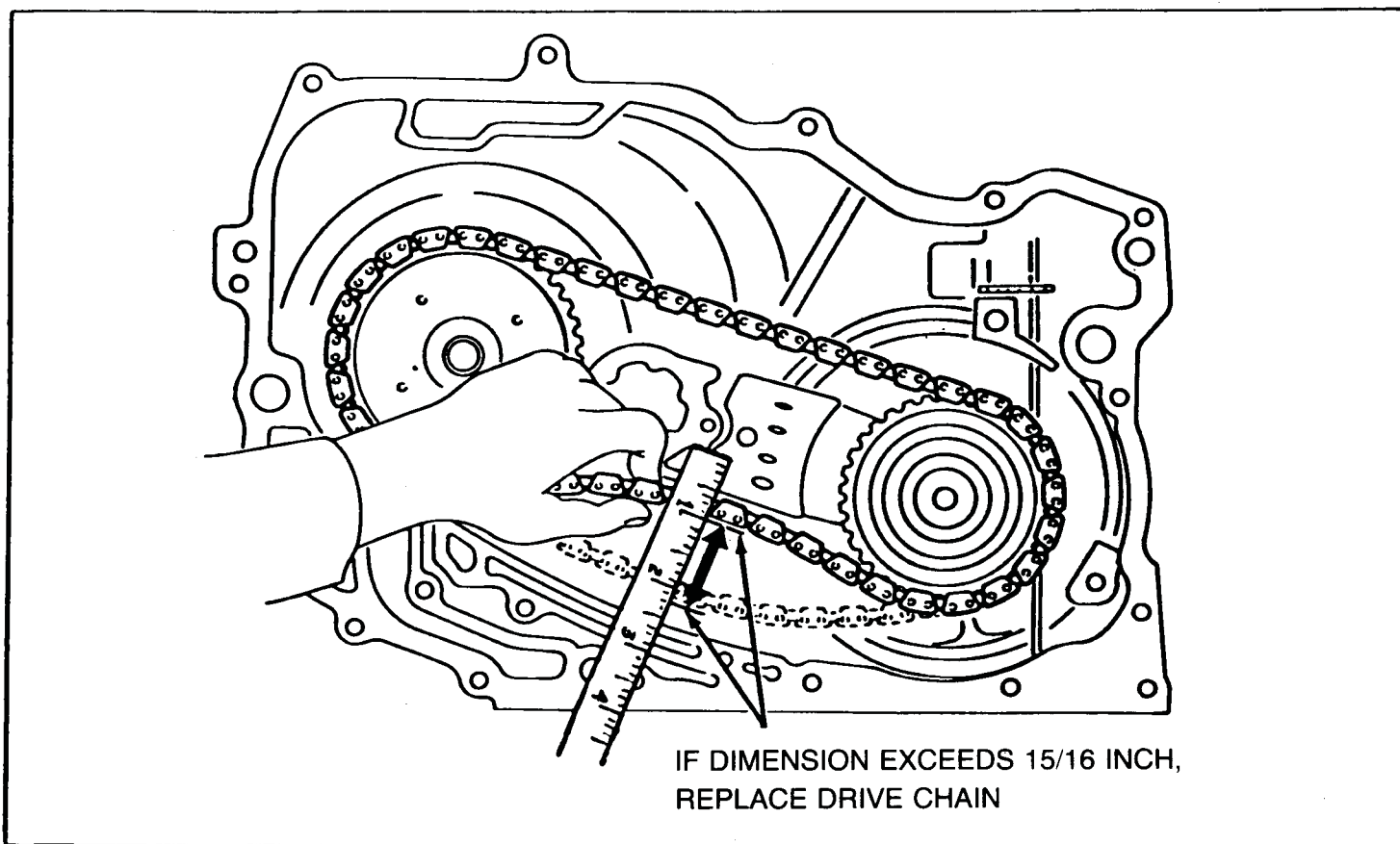

Figure 49

AUTOMATIC TRANSMISSION SERVICE GROUP



Identification of the case covers on the THM 125/125C transaxles is as follows.

- 1) Part number 8653968 has "Two" stands on top of the case cover that are drilled and tapped, and the mount area on the side of the case cover is machined off at 90 degrees to the axle centerline. Refer to Figure 50. This case cover fits "A" and "X" body cars.
- 2) Part number 8653969 has only "One" stand on top of the case cover that is drilled and tapped, and the mount area on the side of the case cover is machined off at 45 degrees to the axle centerline. Refer to Figure 51. This case cover fits "J" body cars.

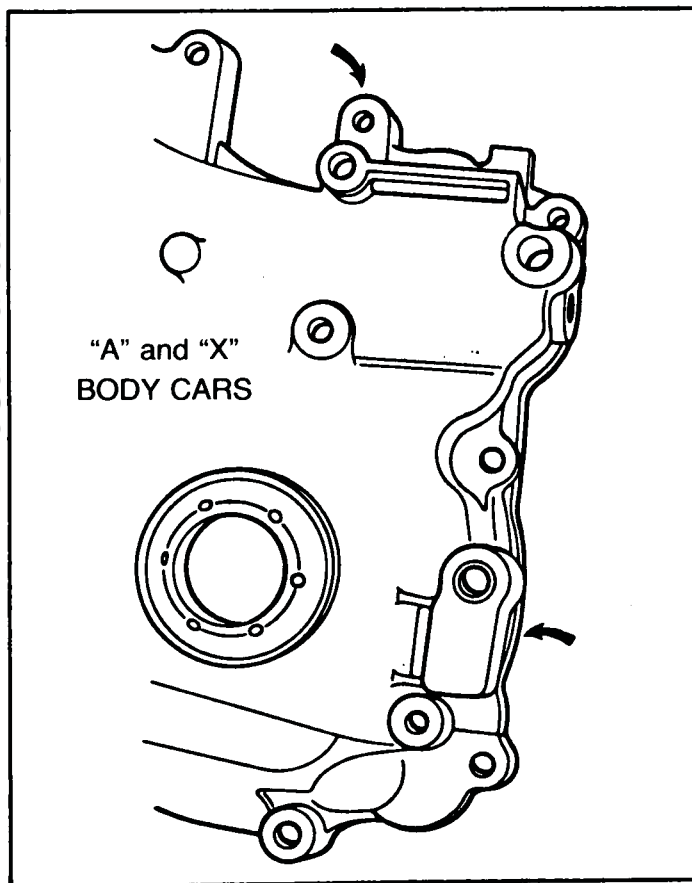

Figure 50

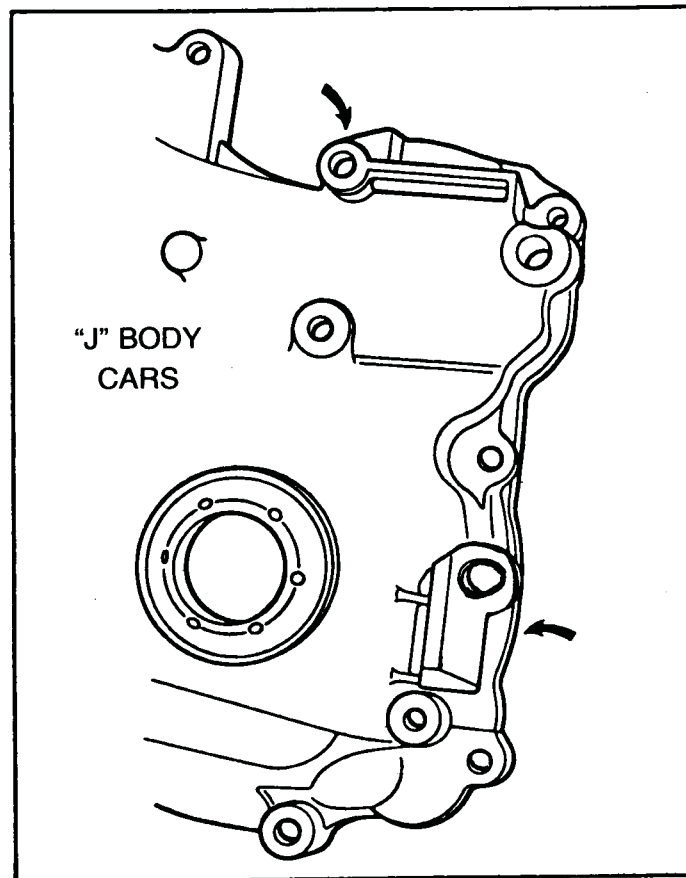

Figure 51

AUTOMATIC TRANSMISSION SERVICE GROUP



Beginning in April, 1984, a slot was added to the case cover of the THM 125/125C transaxle (See Figure 52). The slot was added to the "Drive Feed" oil circuit to allow transmission fluid to spray onto the drive link (Chain) to provide additional lubrication.

The slot is a "V" shaped groove cut into the case cover in the area and direction as shown in Figure 52. The slot can be added to a previous case cover if great care is taken on the depth and the angle, with a small chisel.

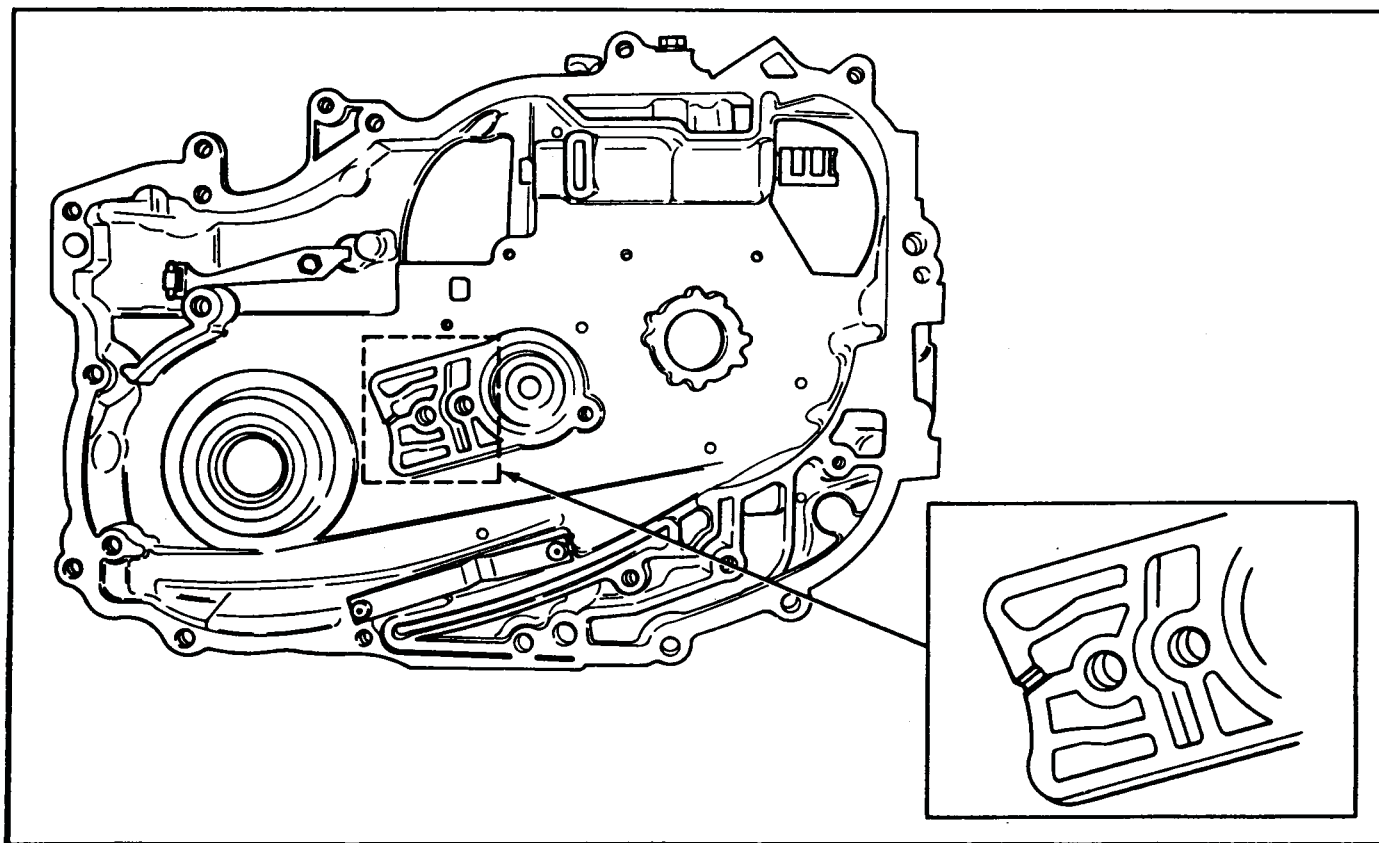

Figure 52

AUTOMATIC TRANSMISSION SERVICE GROUP



At the start of production for 1985, all THM 125/125C transaxles were built with a redesigned forward, and direct clutch housing assemblies. The changes involved in the redesigned forward and direct clutch housings are as follows.

- 1) The 1985 forward and direct lined clutch plates are .010" thinner than previous model lined clutch plates. The 1985 lined plates are identified by a rounded tooth every 90 degrees around the plate, or by a rounded tooth every other tooth (See Figure 55).
- 2) The 1985 direct clutch backing plate is thinner than previous models, and can be identified by "85" stamped on the backing plate (See Figure 54).
- 3) The 1985 direct clutch piston is a different height than previous models, and can be identified by four stamp marks on the top surface (See Figure 54).
- 4) The forward clutch housing top snap ring groove has been moved toward the piston, and can be identified by the chamfer on the inside edge of the housing (Compare Figures 53 and 56).
- 5) The direct clutch housing top snap ring groove has been moved toward the piston, and can be identified by chamfer on the inside edge of the housing (Compare Figures 54 and 57).
- 6) The direct clutch housing bottom snap ring groove is not cut as deep as previous model years (See Figure 58).

NOTE: The component parts of the 1985 production forward clutch assembly, nor direct clutch assembly, are compatible with previous model years and will not interchange. This includes the 1985 production lined clutch plates for both the forward and direct clutch packs.

AUTOMATIC TRANSMISSION SERVICE GROUP

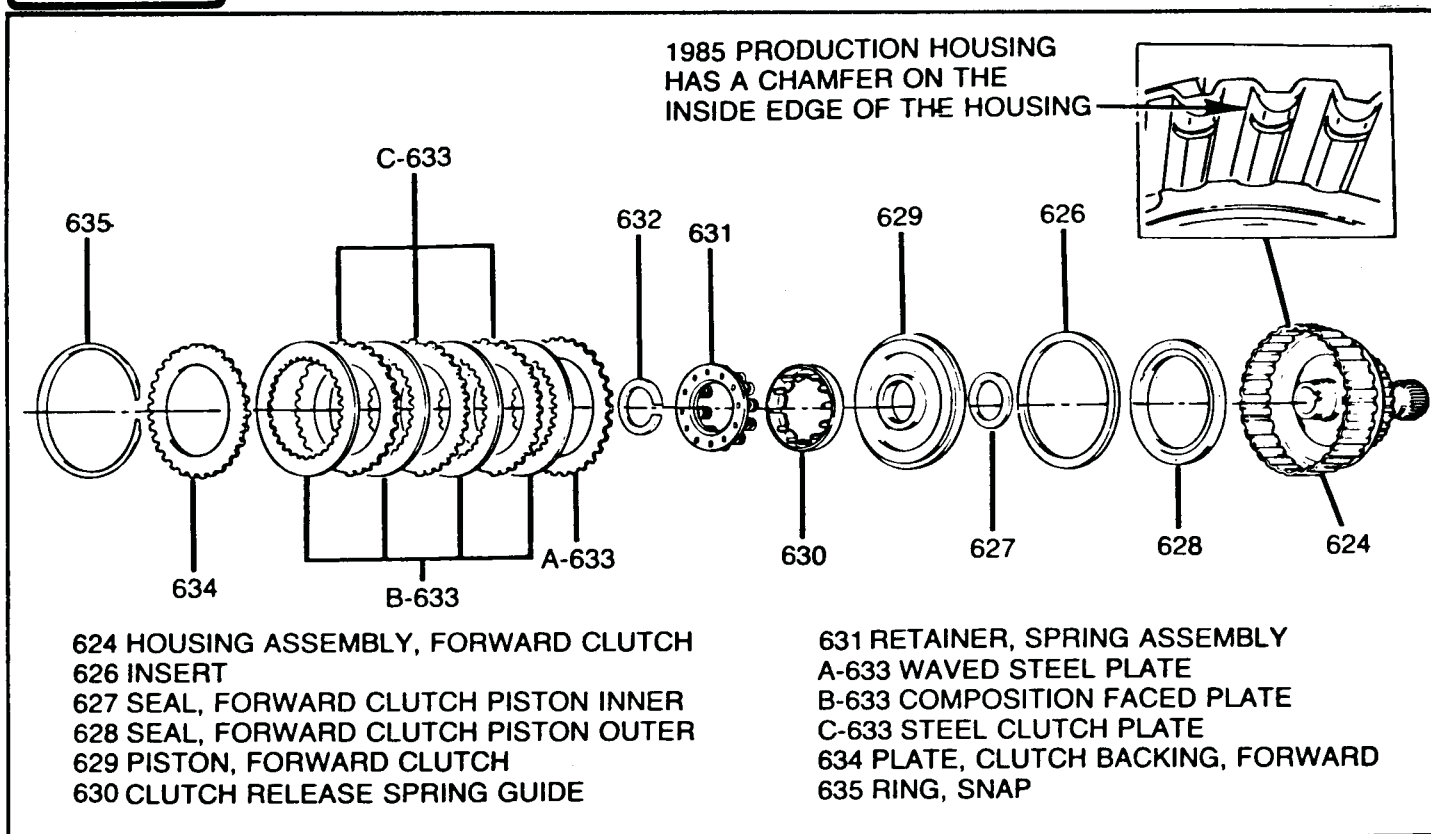

Figure 53

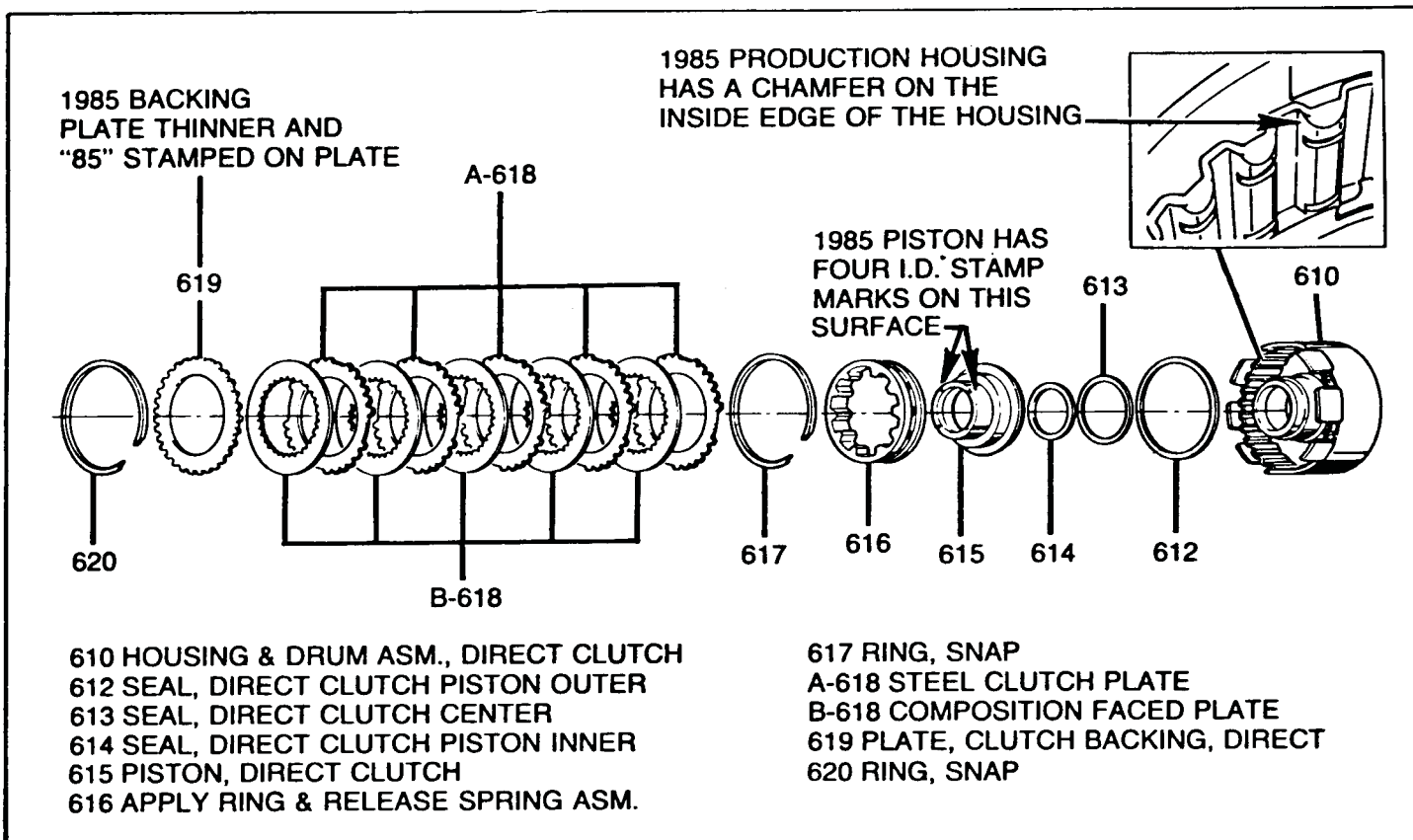
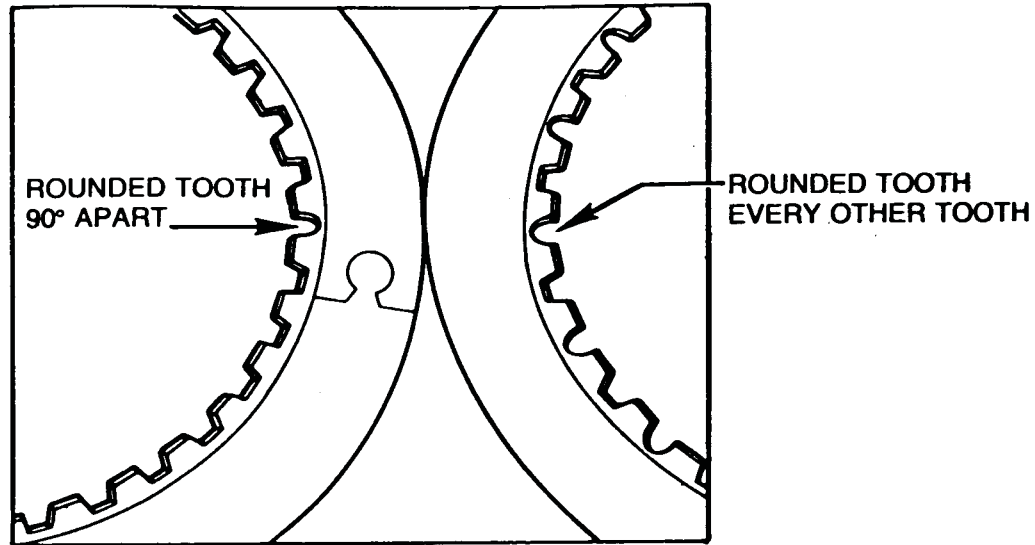

Figure 54



THE 1985 FORWARD AND DIRECT COMPOSITION CLUTCH PLATES ARE APPROXIMATELY 0.254 mm (.010") THINNER THAN PREVIOUS MODEL YEAR COMPOSITION PLATES. THE 1985 COMPOSITION PLATES ARE IDENTIFIED AS SHOWN ABOVE AND THE CLUTCH PACK MAY CONTAIN ONE OR BOTH TYPES.

Figure 55

1984 AND PRIOR FORWARD
CLUTCH HOUSING SERVICE ASSEMBLY
PART NUMBER 8653977

1984 AND PRIOR
SERVICE HOUSING
HAS CHAMFER
WITH A SLOT ON
INSIDE OF FORWARD
CLUTCH HOUSING
ASSEMBLY

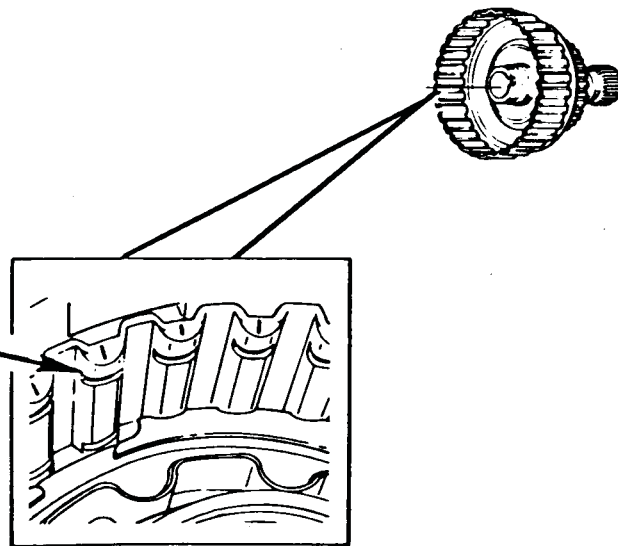
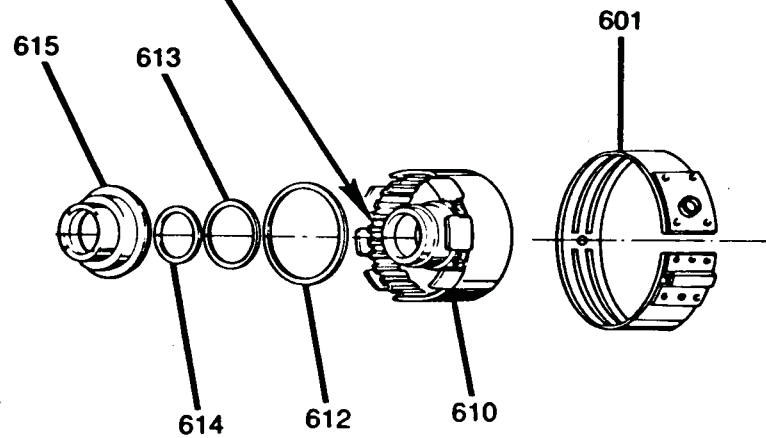

Figure 56

1984 AND PRIOR DIRECT CLUTCH
HOUSING SERVICE PACKAGE PART NUMBER 8653978



1984 AND PRIOR
SERVICE HOUSING HAS
CHAMFER WITH A SLOT
ON INSIDE OF DIRECT
CLUTCH HOUSING ASSEMBLY



601 BAND ASSEMBLY, INTERMEDIATE
610 HOUSING & DRUM ASM., DIRECT CLUTCH
612 SEAL, DIRECT CLUTCH PISTON OUTER

613 SEAL, DIRECT CLUTCH CENTER
614 SEAL, DIRECT CLUTCH PISTON INNER
615 PISTON, DIRECT CLUTCH

Figure 57

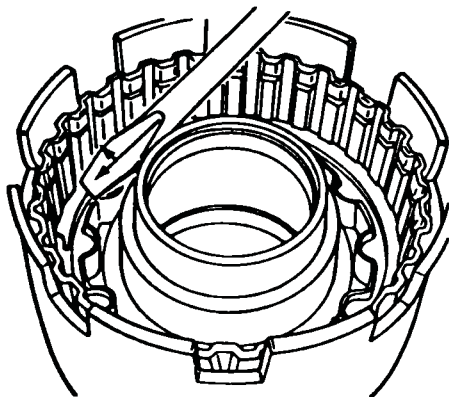

FIGURE A

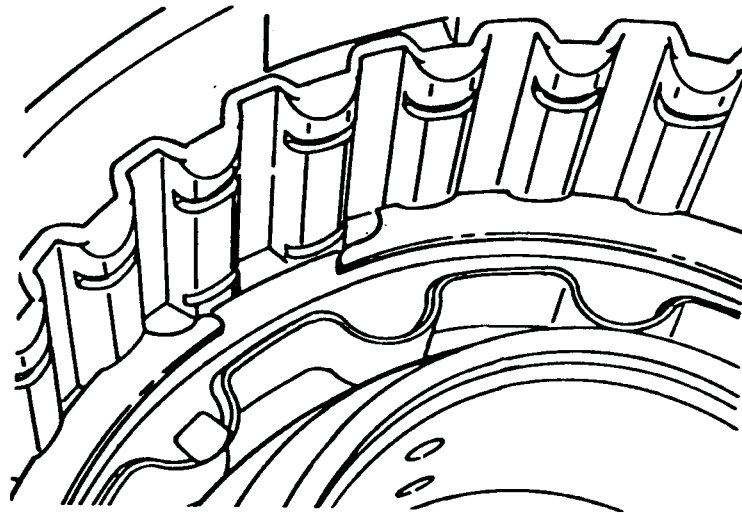

FIGURE B

SERVICE NOTE: THE SNAP RING THAT RETAINS THE APPLY RING AND RELEASE SPRING ASSEMBLY MAY NOT APPEAR TO BE FULLY SEATED IN THE SNAP RING GROOVE WHEN INSTALLED. THIS IS DUE TO THE GROOVE NOT BEING CUT AS DEEP AS PREVIOUS MODEL YEARS (SEE FIGURE B). WHEN INSTALLING THE SNAP RING USE A DOWNWARD AND OUTWARD PRESSURE TO ENSURE PROPER SEATING (SEE FIGURE A).

Figure 58



Servo Cup Plug

Beginning April 11, 1985 for Canadian models, and April 15, 1985 for U.S. models, THM 125/125C transaxles were produced using a case with the air bleed orifice behind the intermediate servo eliminated. See Figure 60. Figure 59 shows the previous design.

Either transaxle case can be used for all applications on 1984 or later models.

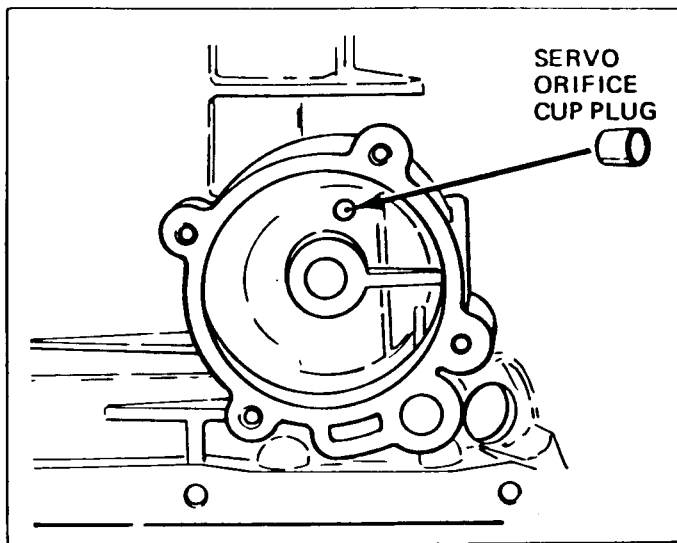

Figure 59

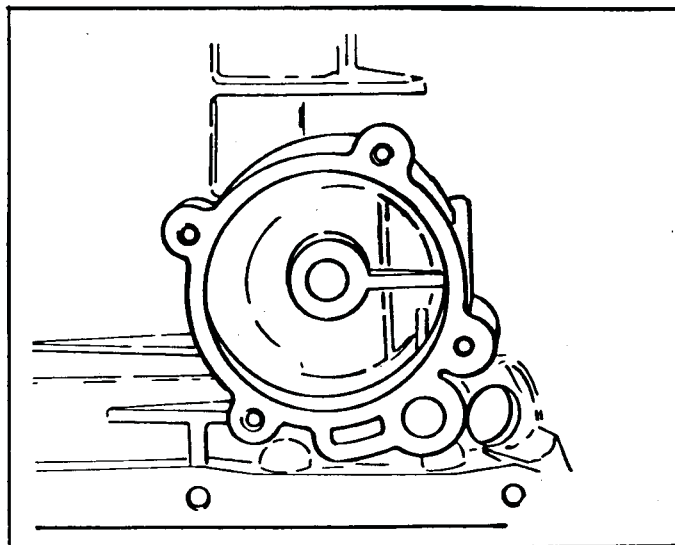

Figure 60

AUTOMATIC TRANSMISSION SERVICE GROUP



Beginning January, 1986, THM 125/125C transaxles were produced with a redesigned oil filter and seal assembly (See Figure 61). Previous design oil filter and seal are shown in Figure 62.

The 2nd design was to eliminate a slipping in all ranges condition under hard acceleration and/or cornering maneuvers, caused by an oil pressure drop due to a cut or improperly seated oil filter seal.

Either design oil filter can be used to service all years and all models as long as the proper seal is used based on the design of the oil filter neck. The "O" ring seal is used only with the short shouldered filter neck (1st Design Figure 62), and the lip seal is used only with the long shouldered filter neck (2nd Design Figure 61).

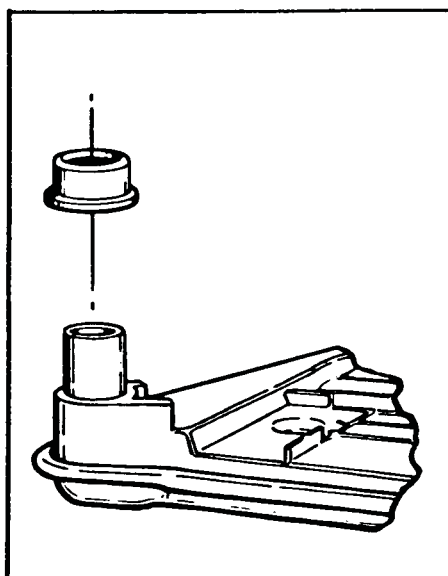

Figure 61

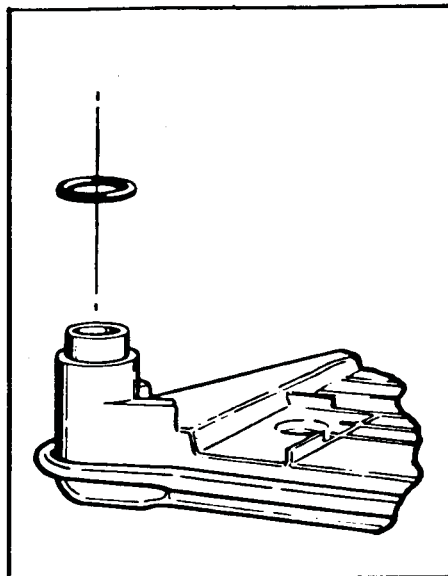

Figure 62

AUTOMATIC TRANSMISSION SERVICE GROUP



THM 125C

- COMPLAINT:** Harsh 1-2 shift encountered on 1985-86 THM 125C transmissions.
- CAUSE:** Too small an orifice in separator plate (.040) 1-2 ACCUMULATOR FEED BACK ORIFICE.
- CORRECTION:** Drill orifice to (.125) or replace with part number 8660581.

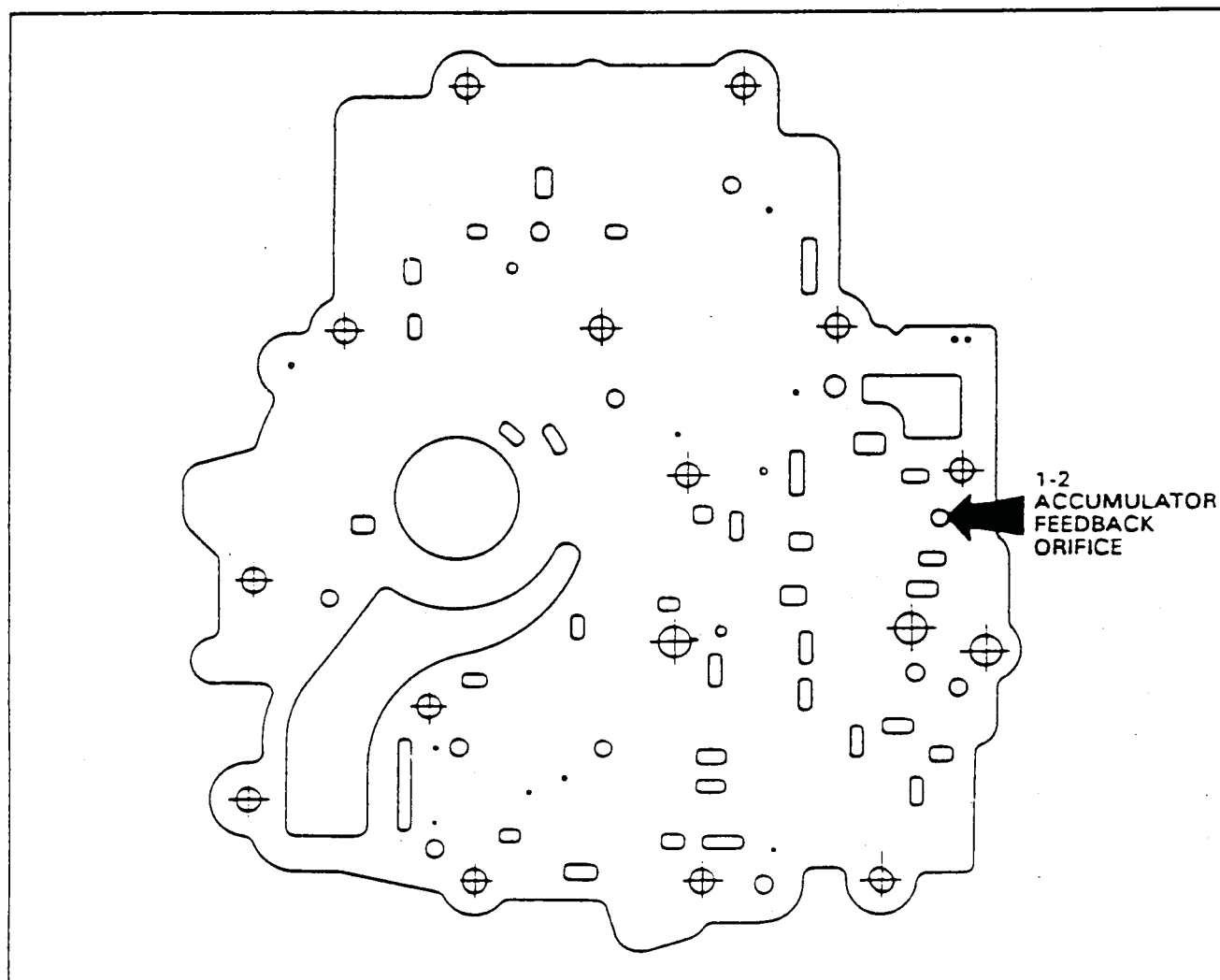

Figure 63

AUTOMATIC TRANSMISSION SERVICE GROUP



Beginning production for 1987 models, the following changes occurred.

1987 – AUXILIARY VALVE BODY

CHANGE:

“Orifice Control Valve” installed in the bore where the T.C.C. regulator valve was previously.

The T.C.C. regulator valve has been eliminated.

(See Figure 64)

REASON:

To provide an additional channel to apply the intermediate band on 3–2 detent or part throttle downshift, for improved intermediate band durability.

PARTS AFFECTED:

1. Auxiliary Valve Body (See Figure 64).
2. Auxiliary Valve Body Cover Gasket (See Figure 65).
3. Valve Body and Pump Assembly - Oil channel changes.

INTERCHANGEABILITY:

None of the parts affected, listed above, are interchangeable with previous models.

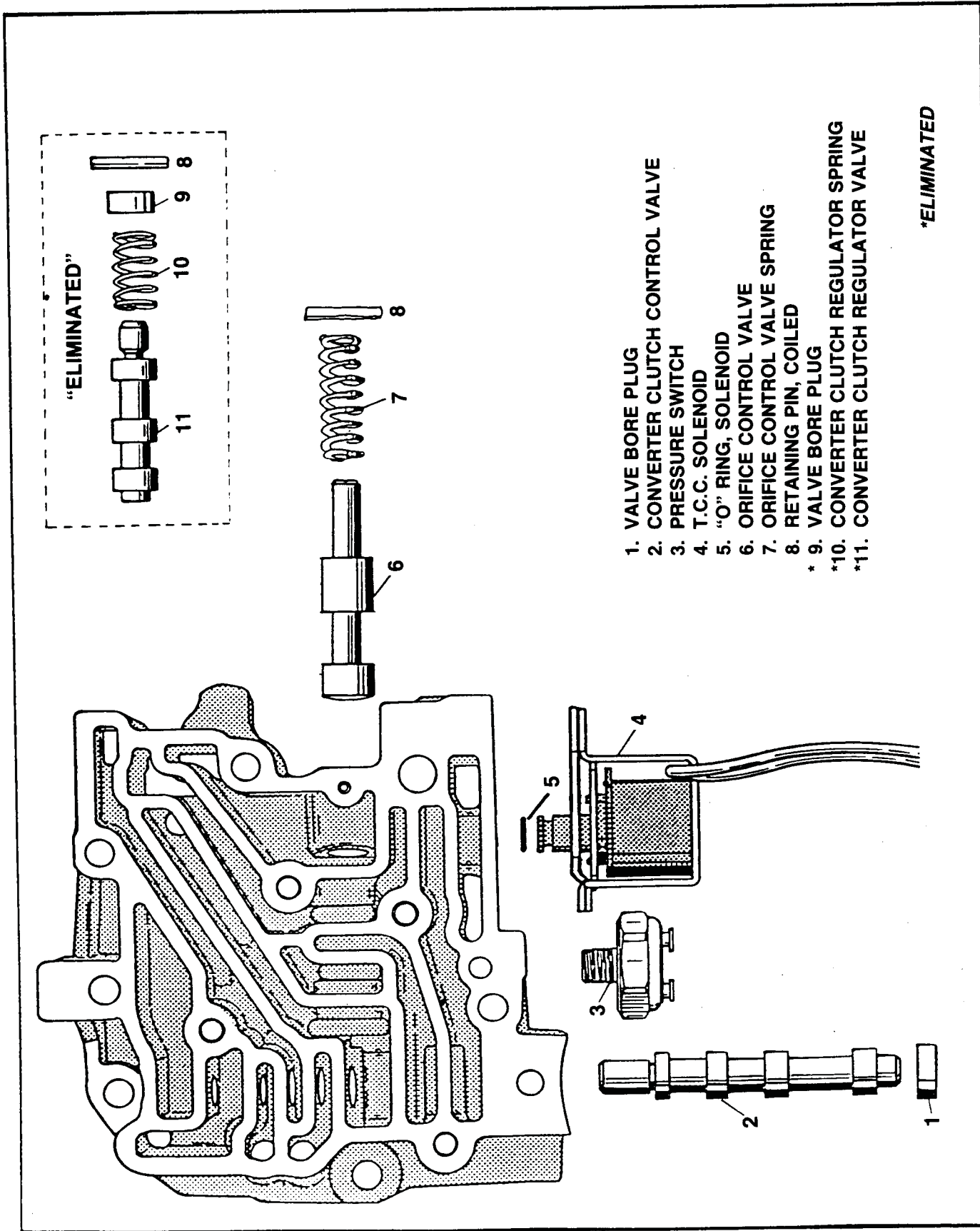
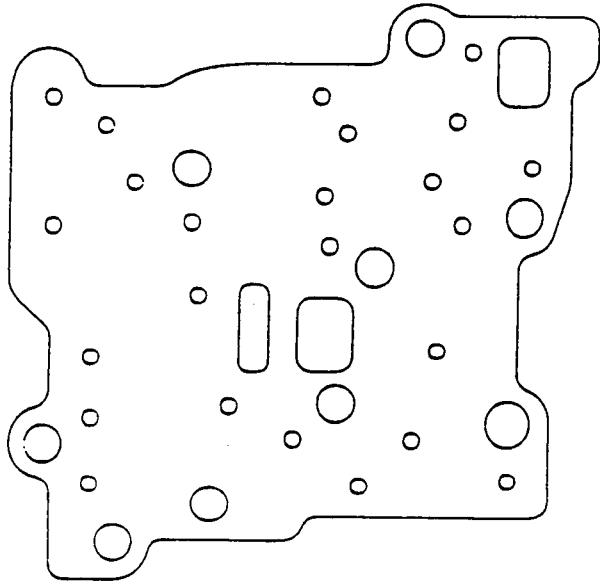

Figure 64



ProCarManuals.com



1982-83

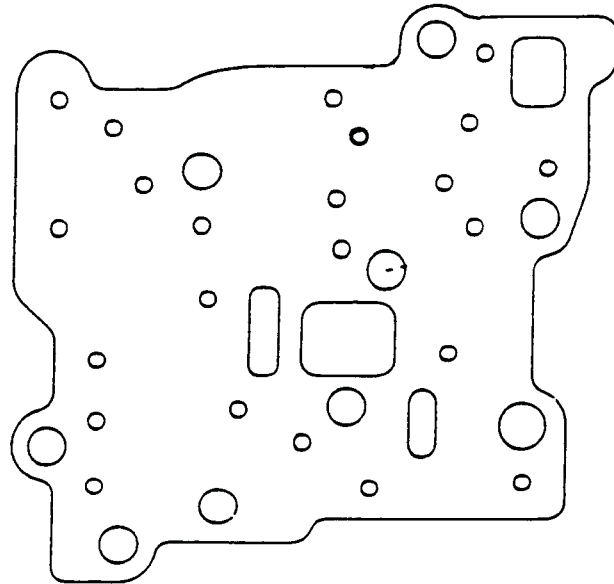

1984-86

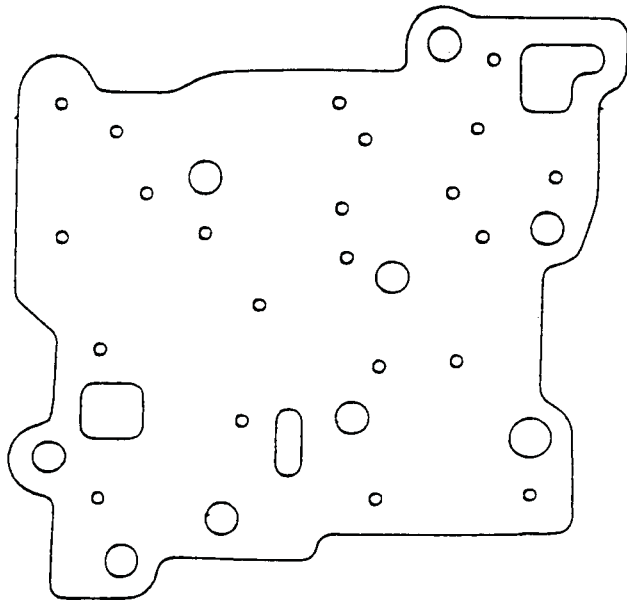

1987

AUXILIARY VALVE BODY GASKETS

82-83	8653947
84-86	8643863
1987	8660795

Figure 65

AUTOMATIC TRANSMISSION SERVICE GROUP



1987 – FORWARD CLUTCH PACK

CHANGE:

Addition of a wave plate, one on each end of the forward clutch pack for a total of two, in the forward clutch housing (See Figure 66).

REASON:

Improved garage shift feel from park to drive.

PARTS AFFECTED:

1. Two wave plates instead of one.
2. Forward clutch Backing Plate (Now Selective). Backing plate stamped "A", "B", "C", "D", with "A" being the thickest, and "D" being the thinnest.

INTERCHANGEABILITY:

Will retro fit, and is recommended, back to 85 and 86 only. Not compatible with 1984 and earlier models.

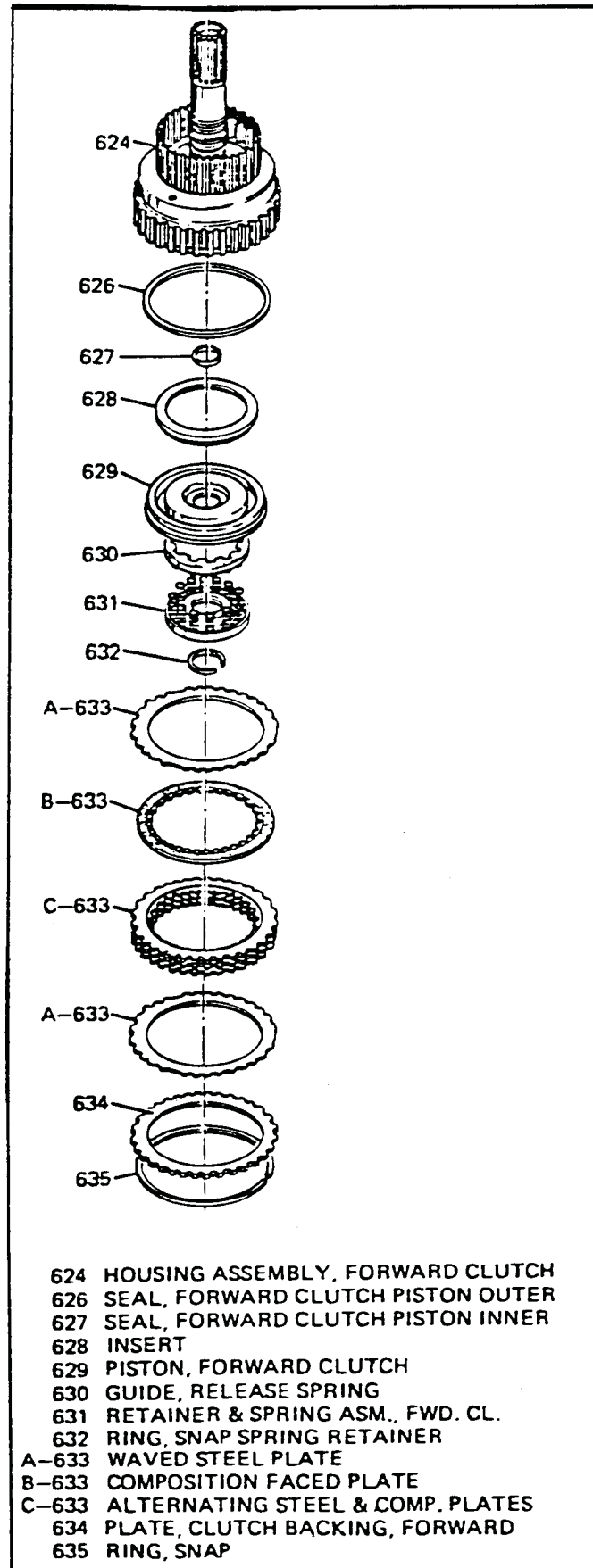

Figure 66



1987 – LOW AND REVERSE CLUTCH PACK

CHANGE:

Addition of a wave plate, one on each end of the low and reverse clutch pack, for a total of two (See Figure 67).

REASON:

Improved garage shift feel from park to reverse.

PARTS AFFECTED:

1. Two Wave Plates (See Figure 67).
2. Low and Reverse Backing Plate, External lugs removed and now selective (See Figure 67). Backing plate stamped "6", "7", "8", "9", with "6" being the thinnest and "9" being the thickest.
3. Low and Reverse Piston, now cast aluminum instead of stamped steel.

CAUTION: There are two different cast aluminum low and reverse pistons, casting No. 8643787, and casting No. 8660826. They use different retainers and are not compatible (Figure 68).

4. Low and Reverse Clutch Spring Retainer (See Figure 68).

INTERCHANGEABILITY:

Will retro fit, and is recommended, as long as compatible parts are used. It will only fit back to 1984, not to be used in 1983 or earlier.

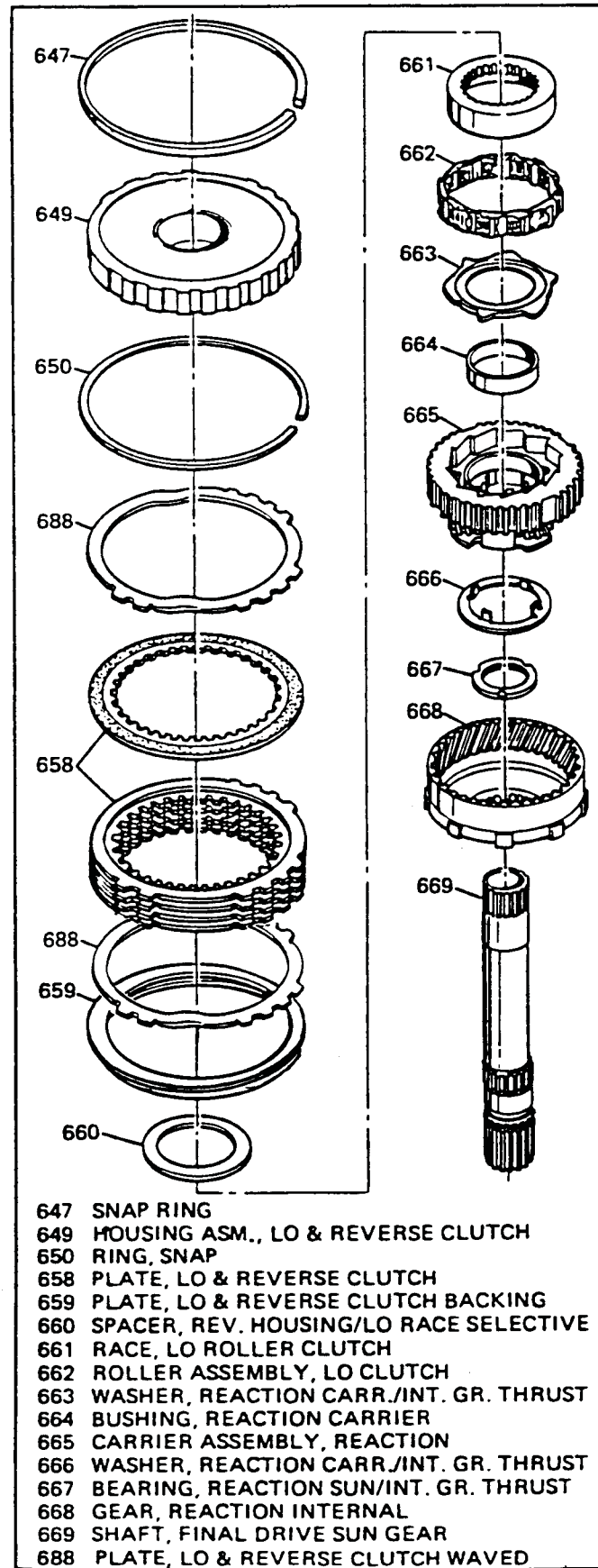

Figure 67

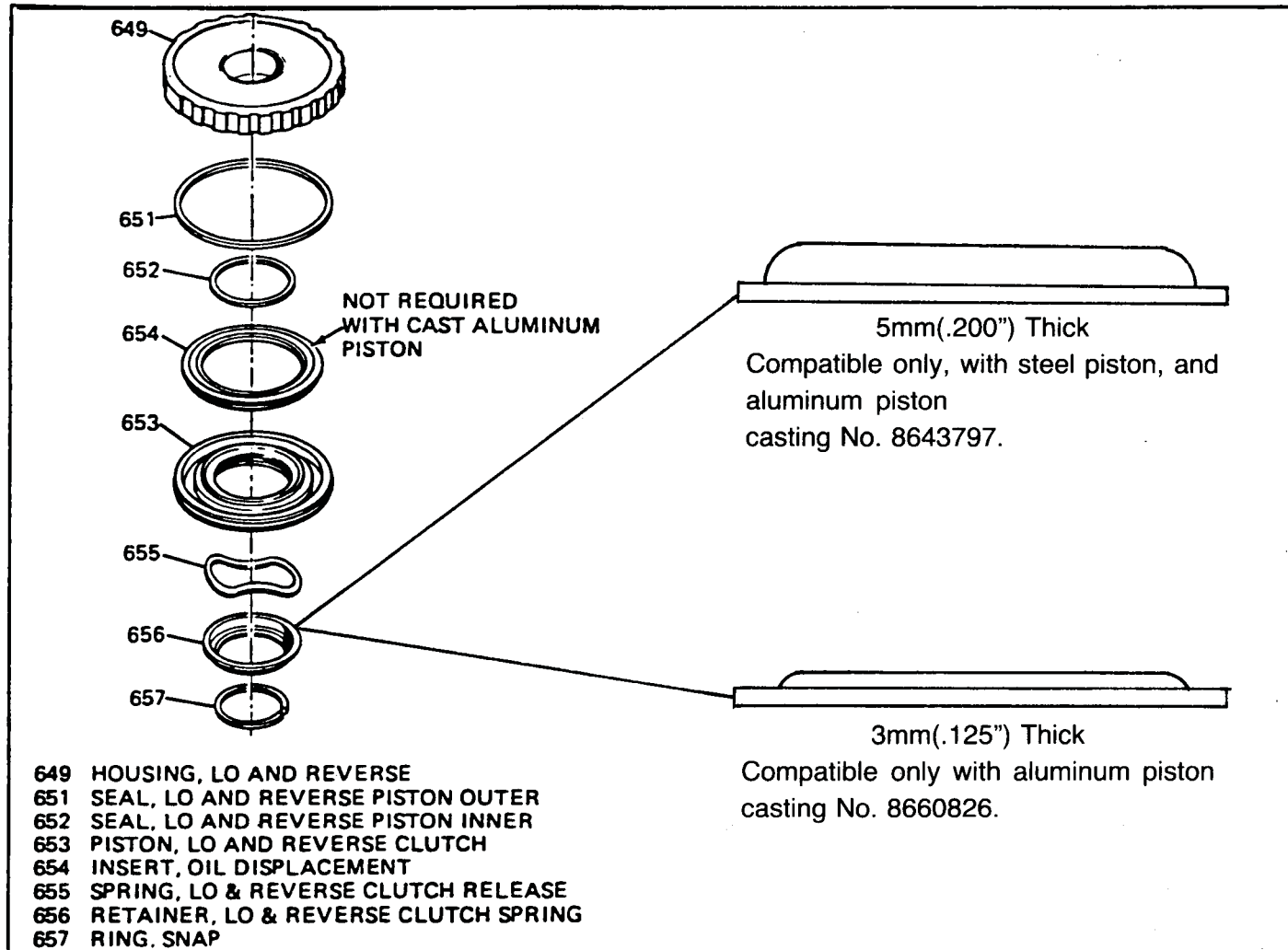

Figure 68



1987 – ELECTRONIC SPEED SENSOR

Electronic speed sensor added for anti-skid braking, and is not interchangeable with previous models (See Figure 69).

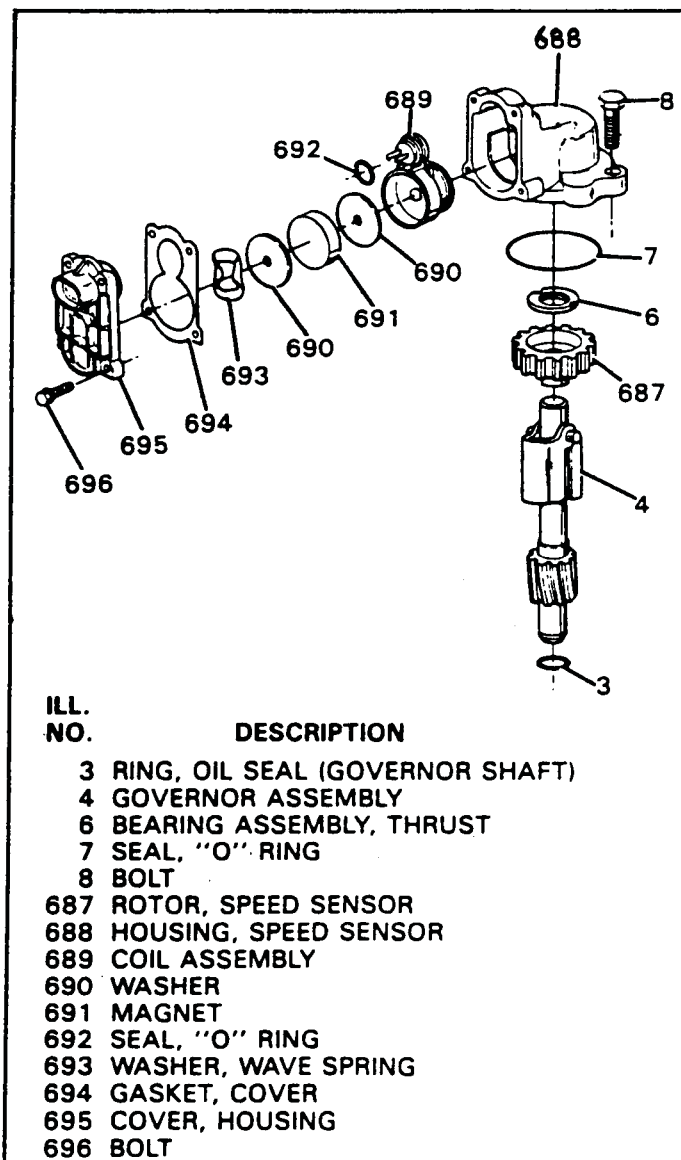

Figure 69

AUTOMATIC TRANSMISSION SERVICE GROUP

**ATSG**

Technical Service Information

1987 – GOVERNOR SCREEN ADDED

The governor screen was added in 1987 to the governor sleeve in the case, to minimize the possibility of sediment entering the governor assembly and preventing the governor balls from seating properly (See Figure 70).

A machining change was necessary in the case to make room for the new governor screen, thus it will not retro-fit to previous models.

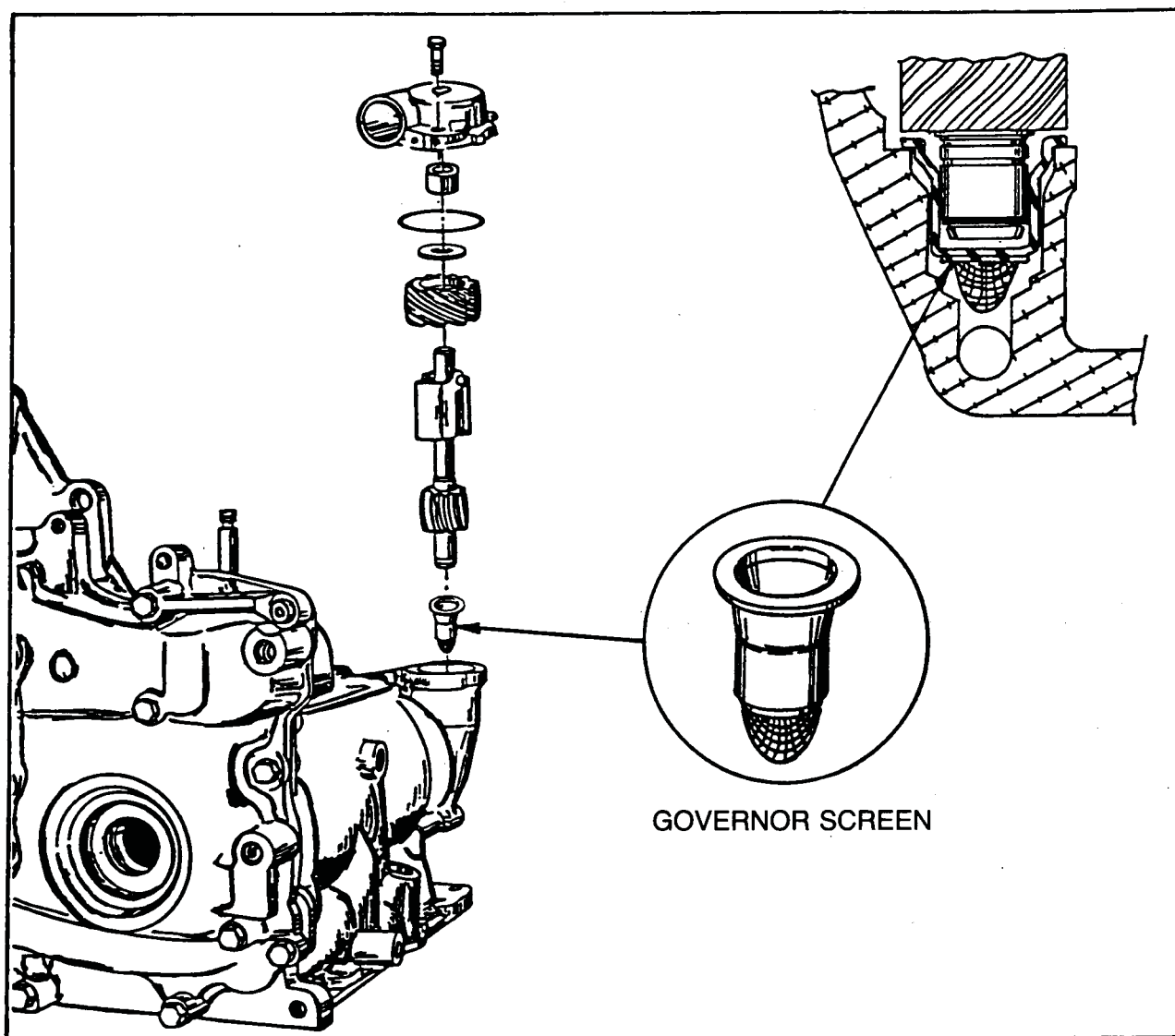

Figure 70

AUTOMATIC TRANSMISSION SERVICE GROUP

1987 – NEW GOVERNOR COVER AND BEARING

A caged needle bearing assembly has been added to the governor cover beginning in model year 1987 (See Figure 71).

The new governor cover and bearing assembly will interchange with the previous models, as an assembly.

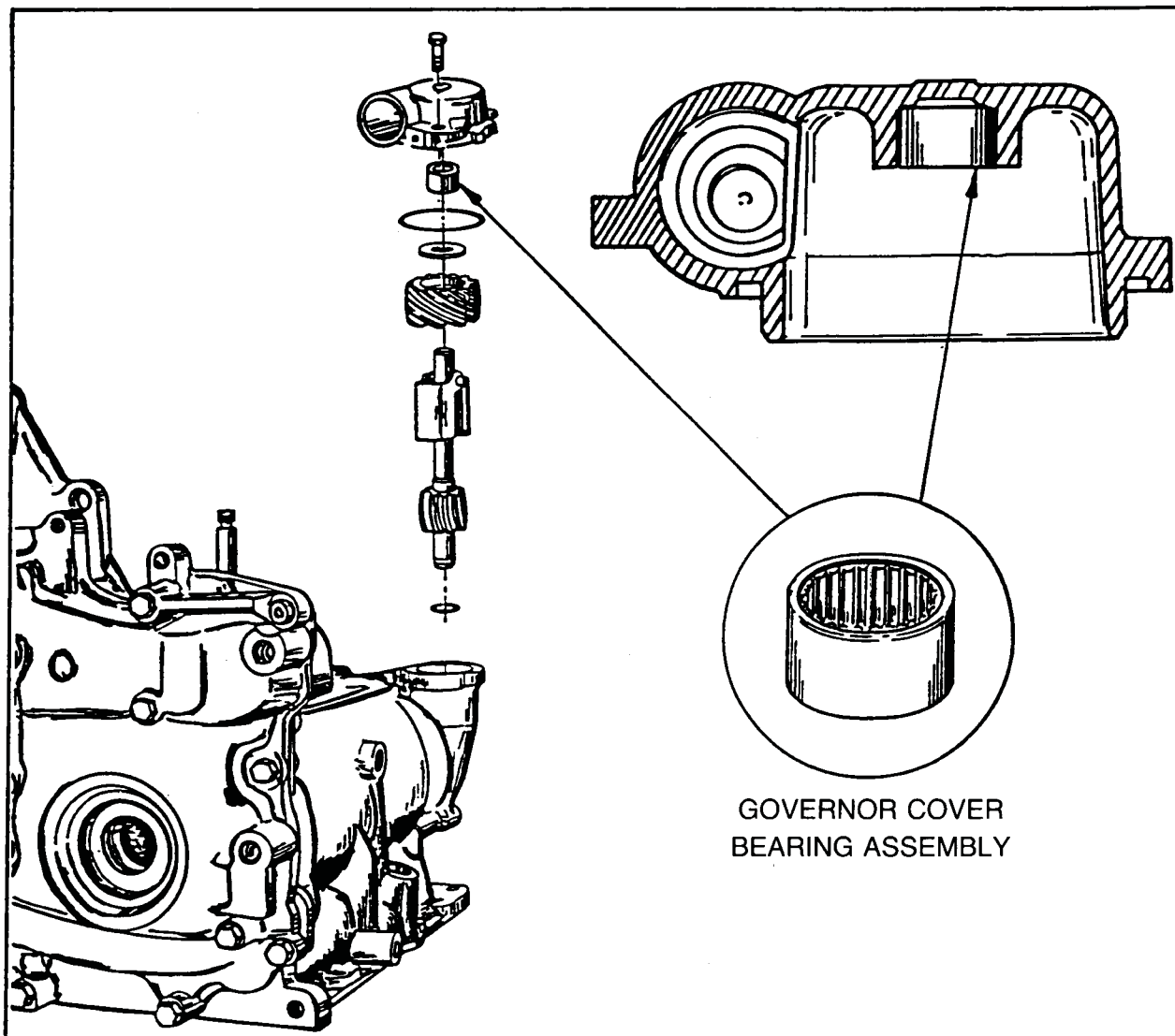

Figure 71

AUTOMATIC TRANSMISSION SERVICE GROUP



1987 – NEW LOW/REVERSE PIPE SEAL

For 84 days in 1987, (Julien Date 012 to Julien Date 096), General Motors built approximately 500,000 THM 125C transaxles using a new design Low/Reverse oil pipe seal (See Figure 72). In April 1987, they returned to the original design seal (See Figure 73).

The 2nd design seal is available ONLY from the General Motors dealer network under OEM Part Number 8664492.

Due to the low quantities involved, the aftermarket manufacturers do not plan, at this time, to include the new seal in their kits, and at present time is not included in the OEM kits.

The new seal must be ordered separately.

LOW/REVERSE OIL PIPE SEAL (2nd Design) 8664492

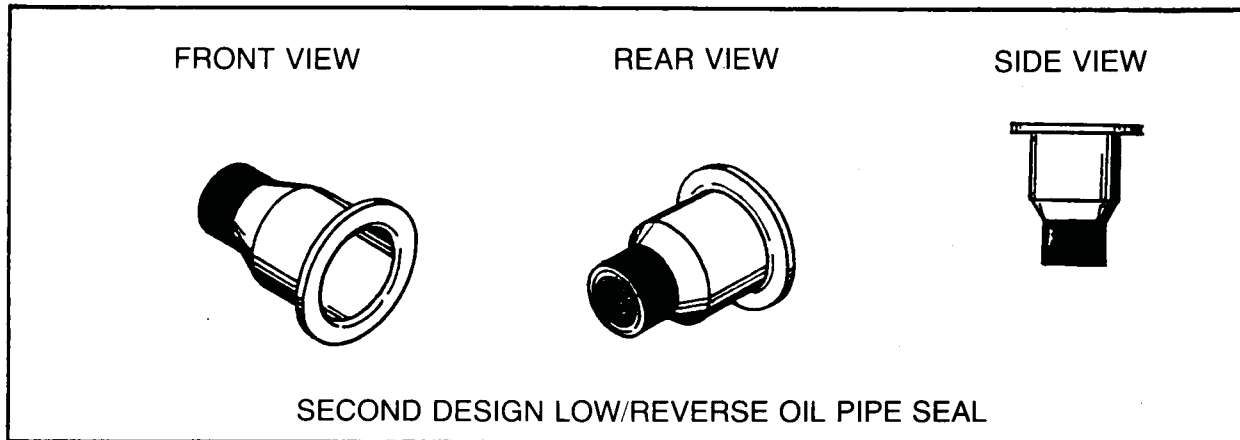

Figure 72

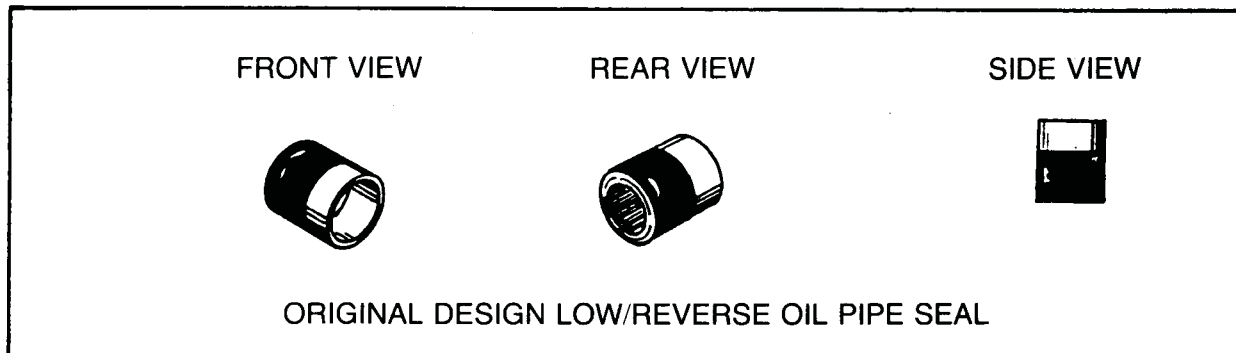

Figure 73



1987 – CONVERTER CLUTCH SCREEN ADDED

A TCC filter has been added to the TCC signal passage in the auxiliary valve body, beginning in March, 1987 (See Figure 74). This will reduce the possibility of sediment entering the converter clutch solenoid.

If the solenoid gets contaminated with sediment, it could result in a complaint of engine stalling when selector is placed into drive or reverse.

The filter cannot be used in previous models because of a machining needed on the auxiliary valve body.

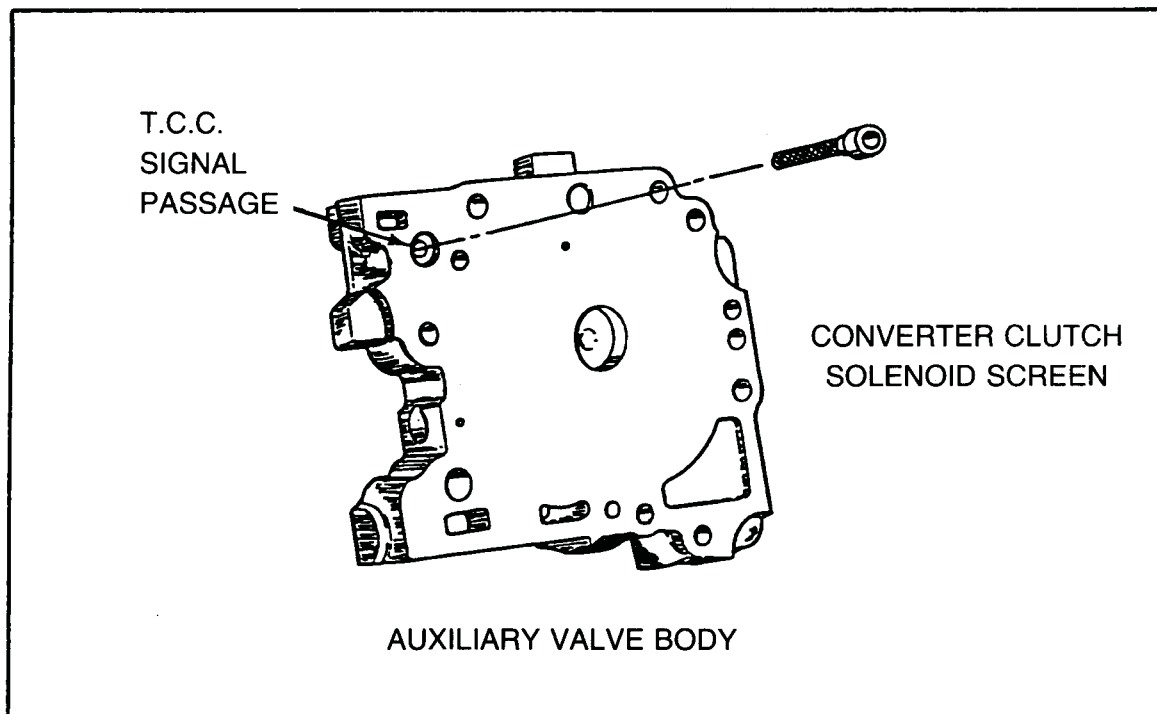

Figure 74



1987 – THERMO ELEMENT ADDED INSIDE MANUAL VALVE

There has been a thermo element added to the inside bore of the manual valve on all THM 125C transaxles, beginning in model year 1987, for improved garage shifts to drive and reverse (See Figure 75).

The retaining clip for the thermo element may break allowing the thermo element to move forward, allowing drive and/or reverse oil to exhaust (See Figure 75). A retaining clip that has broken and fallen out can usually be located in the bottom pan.

The retaining clip is not presently available as a service item. You must purchase the complete manual valve assembly. The previous design manual valve will fit the bore of the case cover, and work fine.

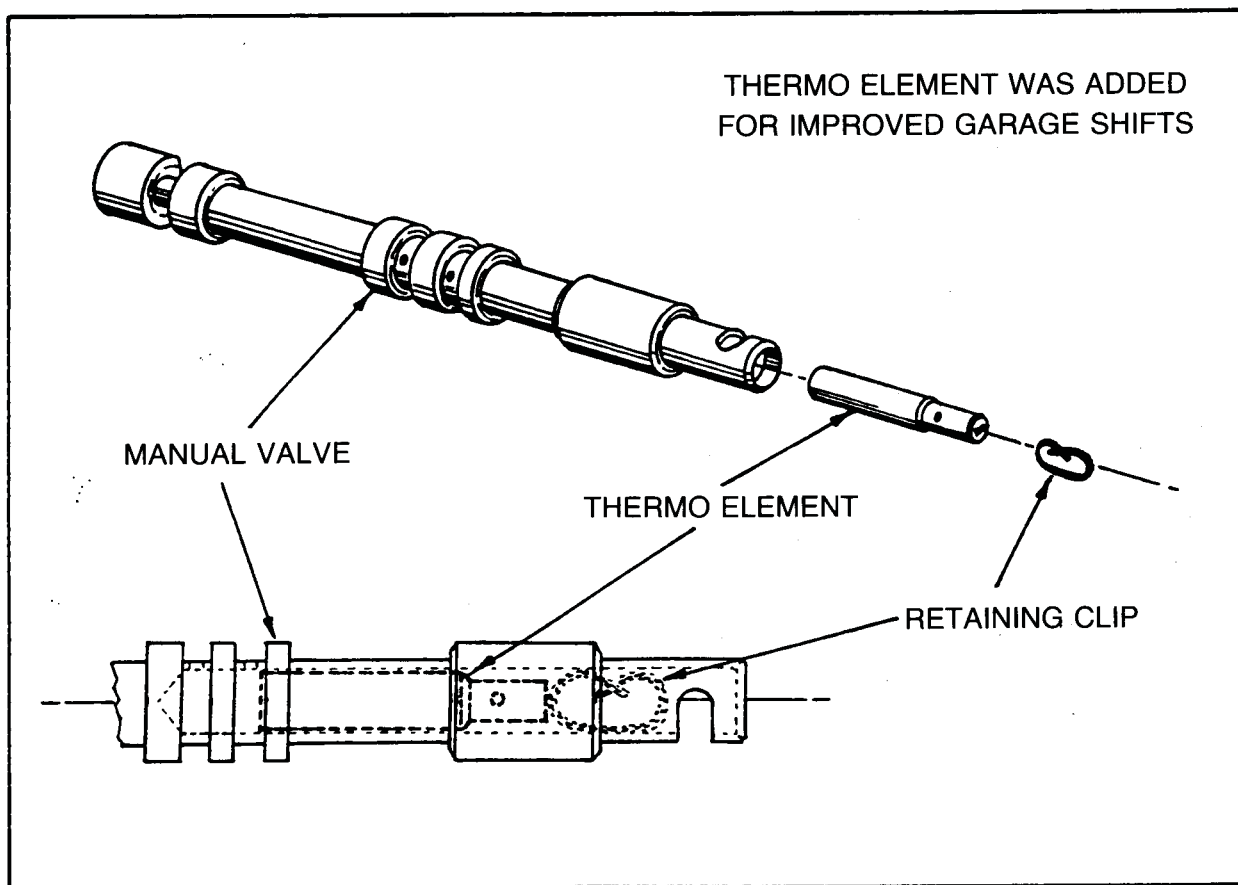

Figure 75

AUTOMATIC TRANSMISSION SERVICE GROUP



THM 125C New Auxiliary Valve Body Gasket

For 1988, approximately 15% of the THM 125C transaxles require a new auxiliary valve body cover gasket. The new gasket is being used in "N" body cars (Calais, Somerset, and Grand AM) ONLY at this time.

The new gasket has a larger hole than the 1987 gasket, and a dyed area on the gasket for identification (See Figure 76).

This now makes four (4) auxiliary valve body cover gaskets for the THM 125C, and they "CANNOT" be interchanged with each other. (See Figure 76).

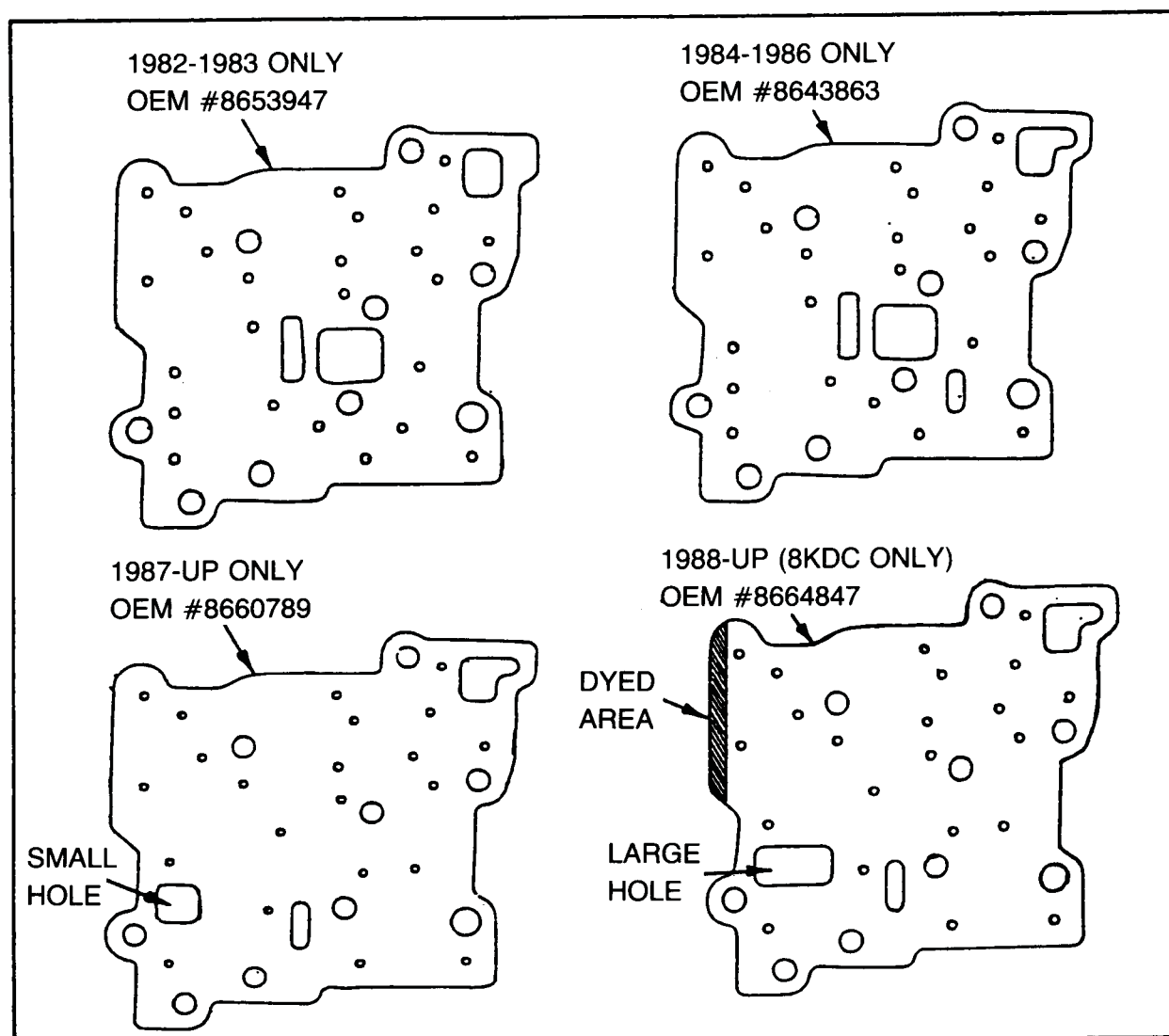

Figure 76

AUTOMATIC TRANSMISSION SERVICE GROUP

THM 125C

PUMP ROTOR AND PUMP SLIDE CHANGES

CHANGE: Beginning in late 1985, the dimensions of the pump rotor and pump slide changed (See Figure 77).

REASON: Improved pump capacity.

PARTS AFFECTED:

- (1) PUMP ROTOR - The outside diameter of the rotor was made smaller. The previous rotor O.D. was 2.235", and the present rotor O.D. is 2.210". (See Figure 77).
- (2) PUMP SLIDE - The height of the pump slide stop was made shorter. The previous pump slide stop measures .426", and the present pump slide stop measures .406" (See Figure 77).

INTERCHANGEABILITY:

The pump rotor and pump slide are interchangeable, "ONLY AS A SET". You CANNOT mix these parts.

- (1) If you install the previous (Large) rotor with the present (Short) slide, interference will result and usually strip the rotor splines.
- (2) If you install the present (Small) rotor with the previous (Tall) slide, erratic line pressures can be encountered.
- (3) DO NOT MIX THESE PARTS.

SERVICE INFORMATION:

Description	Size	Part Number
PUMP ROTOR (SMALL)	.7054"-.7059"	8652248
PUMP ROTOR (SMALL)	.7059"-.7064"	8652249
PUMP ROTOR (SMALL)	.7064"-.7069"	8652245
PUMP ROTOR (SMALL)	.7069"-.7074"	8652246
PUMP ROTOR (SMALL)	.7074"-.7079"	8652247
PUMP SLIDE (SHORT)	.7068"-.7073"	8652240
PUMP SLIDE (SHORT)	.7074"-.7078"	8652241
PUMP SLIDE (SHORT)	.7079"-.7083"	8652242
PUMP SLIDE (SHORT)	.7084"-.7088"	8652243
PUMP SLIDE (SHORT)	.7089"-.7094"	8652244

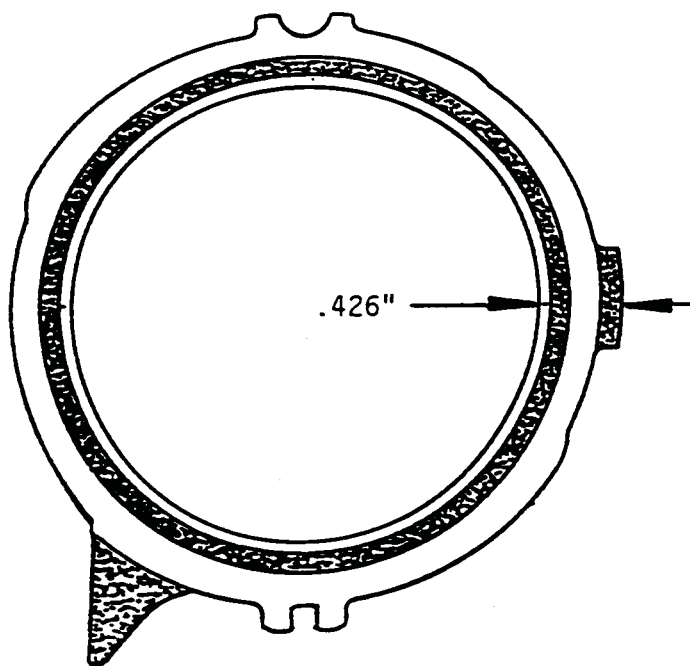

PREVIOUS PUMP SLIDE

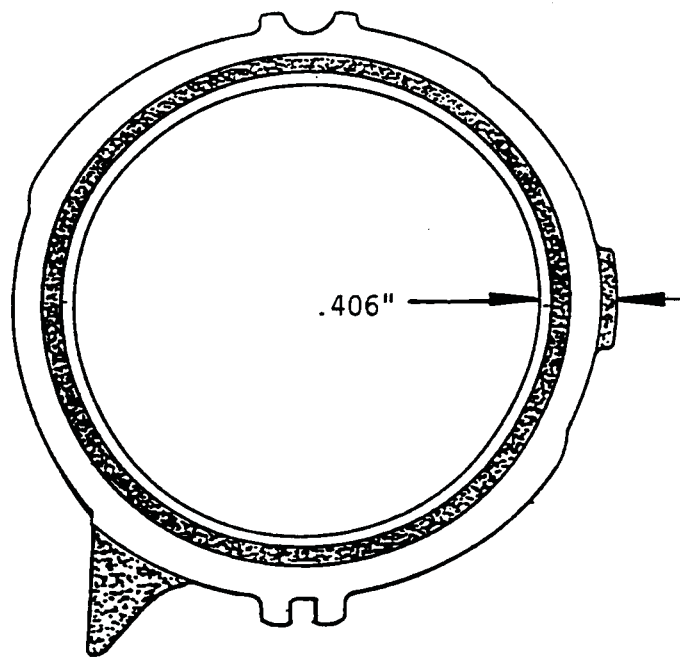

PRESENT PUMP SLIDE

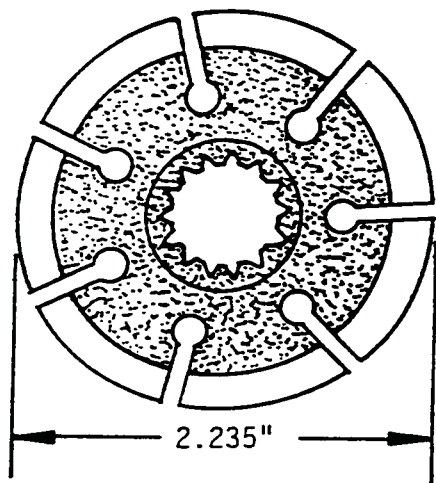

PREVIOUS PUMP ROTOR

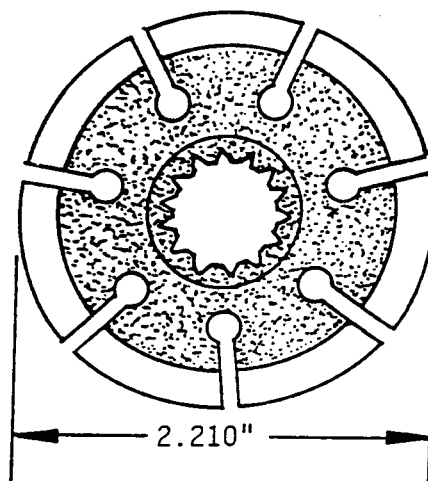

PRESENT PUMP ROTOR

Copyright 1989 ATSG

Figure 77



THM 125C

NEW FORWARD CLUTCH HOUSING

CHANGE: A new design forward clutch housing and thrust washer went into production on November 3, 1987, for all 1988 model 125C transaxles.

REASON: The new housing contains a new stamped channel which increases forward clutch feed oil, providing a quicker neutral to drive engagement. (See Figure 78).

PARTS AFFECTED:

- (1) FORWARD CLUTCH HOUSING - Contains a stamped channel which increases the flow of forward clutch feed oil, and there is a revised dimension where the bronze washer is located (See Figure 78).
- (2) BRONZE THRUST WASHER - Revised dimension on the inside diameter of washer to fit the new clutch housing, and identified with a dimple stamped on both sides of the washer (See Figure 78).

INTERCHANGEABILITY:

- (1) The new forward clutch housing will retro fit back to all previous models but you MUST use the 3rd design "Dimpled" washer.
- (2) The 1st design plastic washer, and the 2nd design bronze washer will not fit the new forward clutch housing.
- (3) If the 3rd design "Dimpled" bronze thrust washer is used on the previous forward clutch housing, it will create premature wear on the housing and washer.

SERVICE INFORMATION:

Bronze Thrust Washer (2nd Design).....	8652759
Bronze Thrust Washer (3rd Design "Dimpled").....	8664762
Forward Clutch Housing and Washer Kit (1988 Design).....	8664982

AUTOMATIC TRANSMISSION SERVICE GROUP

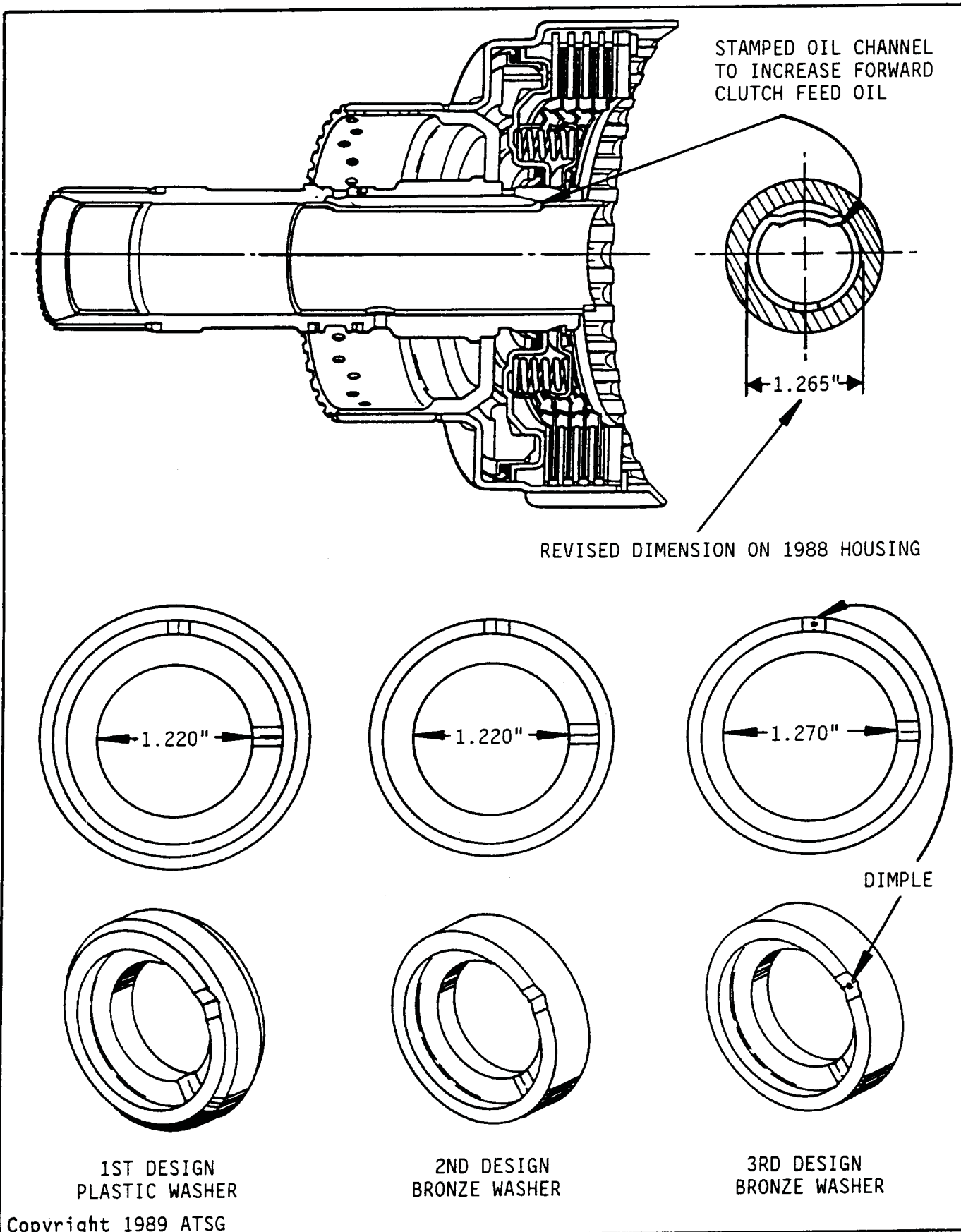

Figure 78

1982 THM 125C MODELS

<u>MODEL</u>	<u>CAR LINE</u>	<u>ENGINE</u>	<u>CONV CODE</u>	<u>STALL SPEED</u>	<u>FINAL DRIVE</u>	<u>SPROCKETS DRIVE-DRIVEN</u>	<u>OVERALL RATIO</u>	<u>USED BY</u>
CE	X	V6 2.8L Chevrolet	FD2	2095	2.84	37-33	2.53	1,
CD	X	V6 2.8L Chev Canada	FD2	2095	2.84	37-33	2.53	1,2,3,4
CT	X	V6 2.8L Chev H/O	FD2	2095	3.33	37-33	2.97	1,3
PZ	X	I4 2.5L Pontiac	FD0*	2095	2.84	38-32	2.39	1,3
PK	X	I4 2.5L Pontiac	FD2	2095	2.84	38-32	2.39	1,3
HX	X	I4 2.5L Pont Canada	FD2	2095	2.84	38-32	2.39	1,3
PI	A,X	I4 2.5L Pont (Altitude)	FD2	2095	2.84	37-33	2.53	1,3
CL	A,X	V6 2.8L Chev (Calif)	FD2	2095	2.84	35-35	2.84	1,3
PW	A,X	I4 2.5L Pontiac	FJ2	2060	2.84	38-32	2.39	1,3
PD	A,X	I4 2.5L Pont (Altitude)	FJ2	2060	2.84	35-35	2.84	1,3
H6	A,X	I4 2.5L Pont Canada	FD2	2095	2.84	38-32	2.39	1,2,3,4,
HM	A,X	V6 2.8L Chev Mexico	FD0*	2095	2.84	35-35	2.84	1,
HS	A	V6 2.8L Chev Canada	FD2	2095	2.84	35-35	2.84	1,2,3,4
HW	A	I4 2.5L Pont Canada	FD2	2095	2.84	38-32	2.39	1,2,3,4
PL	A	I4 2.5L Pont	FD2	2095	2.84	38-32	2.39	1,3
BL	A	V6 3.0L Buick	FE2	1865	2.84	37-33	2.53	3,4
BF	A	V6 3.0L Buick (Perf)	FE2	1865	3.33	37-33	2.97	3,4
OP	A	V6 4.3L Olds Diesel	FH5	1525	2.84	38-32	2.39	1,3,4
CJ	J	I4 1.8L Chevrolet	FBI	2560	2.84	35-35	2.84	1,3
CI	J	I4 1.8L Chevrolet	FBI	2560	2.84	33-37	3.18	1,3
HC	J	I4 1.8L Chev Canada	FZ2	2375	2.84	35-35	2.84	1,3
HY	J	I4 1.8L Chev Canada	FZ2	2375	2.84	33-37	3.18	1,3
CU	J	I4 1.8L Chevrolet	FAL	2795	2.84	33-37	3.18	1,
CF	J	I4 1.8L Chev Altitude	FAL	2795	3.33	33-37	3.73	3,4,5
C3	J	I4 1.8L Chev (Perf)	FAL	2795	3.33	35-35	3.33	5,

1982 THM 125C MODELS (Continued)

<u>MODEL</u>	<u>CAR LINE</u>	<u>ENGINE</u>	<u>CONV CODE</u>	<u>STALL SPEED</u>	<u>FINAL DRIVE</u>	<u>SPROCKETS DRIVE-DRIVEN</u>	<u>OVERALL RATIO</u>	<u>USED BY</u>
HI	J	I4 1.8L Chev Canada	FAL	2795	2.84	35-35	2.84	1,2,3,4
HU	J	I4 1.8L Chev Canada	FAL	2795	2.84	33-37	3.18	1,2,3,4
HR	J	I4 1.8L Chev Canada(Alt)	FAL	2795	3.33	33-37	3.73	1,2,3,4
PG	J	I4 1.8L Brazil	FAL	2795	2.84	33-37	3.18	1,2,3
P3	J	I4 1.8L Brazil (Alt)	FAL	2795	3.33	35-35	3.33	1,2,3
EA	Opel T	I4 1.3L S Opel	FA0*	2795	3.33	33-37	3.73	
EF	Opel T	I4 1.3L N Opel	FA0*	2795	3.33	33-37	3.73	
EK	Opel J,T	I4 1.3L S Opel	FA0*	2795	3.33	33-37	3.73	
EQ	Opel J,T	I4 1.6L S Opel	FC0*	2385	3.33	35-35	3.33	
EB	Opel J	I4 1.6L N Opel	FC0*	2385	3.33	33-37	3.73	
EL	Holden J	I4 1.6L S Opel	FB0*	2560	3.33	35-35	3.33	

- 1 - Chevrolet
- 2 - Pontiac
- 3 - Oldsmobile
- 4 - Buick
- 5 - Cadillac

* - 1982 and up OPEN converter, that is identical in external appearance to the lock-up converter, but they do not have a clutch inside.

1983 THM 125C MODELS

<u>MODEL</u>	<u>CAR LINE</u>	<u>ENGINE</u>	<u>CONV CODE</u>	<u>STALL SPEED</u>	<u>FINAL DRIVE</u>	<u>SPROCKETS DRIVE-DRIVEN</u>	<u>OVERALL RATIO</u>	<u>USED BY</u>
CE	X	V6 2.8L Chevrolet	FD2	2095	2.84	37-33	2.53	1,
HD	X	V6 2.8L Chev Canada	FD2	2095	2.84	37-33	2.53	1,2,3,4
CT	A,X	V6 2.8L Chev H/O	FD2	2095	3.06	35-35	3.06	1,3
CL	A,X	V6 2.8L Chev (Calif)	FD2	2095	2.84	35-35	2.84	1,3
PW	A,X	I4 2.5L Pontiac	FJ2	2060	2.84	38-32	2.39	1,3
PD	A,X	I4 2.5L Pont(Altitude)	FJ2	2060	2.84	35-35	2.84	1,3
HW	A,X	I4 2.5L Pont Canada	FD2	2095	2.84	38-32	2.39	1,2,3,4
HM	A,X	V6 2.8L Chev(Mexi&Colum)	FDO*	2095	3.33	35-35	3.33	1,
CK	A	V6 2.8L Chev Police	FD2	2095	3.06	35-35	3.06	1,
HS	A	V6 2.8L Chev Canada	FD2	2095	2.84	35-35	2.84	1,2,3,4
BL	A	V6 3.0L Buick	FE4	1865	2.84	37-33	2.53	3,4
BF	A	V6 3.0L Buick(Altitude)	FE4	1865	3.33	37-33	2.97	3,4
HV	A	V6 2.8L Chev Venezuela	FD0*	2095	3.06	35-35	3.06	1,
OP	A	V6 4.3L Olds Diesel	FH5	1525	2.84	38-32	2.39	1,2,3,4
CF	J	I4 2.0L Chev(Altitude)	FK1	2760	3.33	33-37	3.73	1,2,3,4
HY	J	I4 2.0L Chev Canada	FK1	2760	2.84	33-37	3.18	1,2,3,4,6
HC	J	I4 2.0L Chev Can(Alt)	FK1	2760	3.33	33-37	3.73	1,2,3,4,6
PG	J	I4 1.8L Pont OHC/FI	FAL	2795	2.84	33-37	3.18	3,4
P3	J	I4 1.8L Pont OHC/FI(Alt)	FAL	2795	3.33	35-35	3.33	3,4
CB	J	I4 2.0L Chevrolet	FK1	2760	2.84	33-37	3.18	1,3
CA	J	I4 2.0L Chevrolet (Alt)	FK1	2760	3.06	33-37	3.43	5,
CC	J	I4 2.0L Chevrolet	FBL	2560	2.84	33-37	3.18	1,2,3,4,5
EF	Opel T	I4 1.3L N Opel	FA0*	2795	3.33	33-37	3.73	
EP	Opel J,T	I4 1.6L D Opel	FA0*	2795	3.33	33-37	3.73	
EK	Opel J,T	I4 1.3L S Opel	FA0*	2795	3.33	33-37	3.73	

1983 THM 125C MODELS (Continued)

<u>MODEL</u>	<u>CAR LINE</u>	<u>ENGINE</u>	<u>CONV CODE</u>	<u>STALL SPEED</u>	<u>FINAL DRIVE</u>	<u>SPROCKETS DRIVE-DRIVEN</u>	<u>OVERALL RATIO</u>	<u>USED BY</u>
EQ	Opel J,T	I4 1.6L S Opel	FC0*	2385	3.33	35-35	3.33	
EI	Opel J	I4 1.8L E Opel	FC0*	2385	3.33	35-35	3.33	
EB	Opel J	I4 1.6L N Opel	FC0*	2385	3.33	33-37	3.73	
EL	Holden J	I4 1.6L S Opel	FB0*	2560	3.33	35-35	3.33	
EM	Isuzu J	I4 2.0L Isuzu	FC1	2385	3.33	35-35	3.33	
EN	Isuzu J	I4 2.0L Isuzu Diesel	FB1	2560	3.33	35-35	3.33	
EW	Isuzu J	I4 2.0L Isuzu Turbo-Dsl	FD2	2095	3.33	35-35	3.33	

- 1 - Chevrolet
- 2 - Pontiac
- 3 - Oldsmobile
- 4 - Buick
- 5 - Cadillac
- 6 - Canada

* - 1982 and up OPEN converter, that is identical in external appearance to the lock-up converter, but they do not have a clutch inside.

1984 THM 125C MODELS

<u>MODEL</u>	<u>CAR LINE</u>	<u>ENGINE</u>	<u>CONV CODE</u>	<u>STALL SPEED</u>	<u>FINAL DRIVE</u>	<u>SPROCKETS DRIVE-DRIVEN</u>	<u>OVERALL RATIO</u>	<u>USED BY</u>
CE	X	V6 2.8L Chev	FD2	2095	2.84	37-33	2.53	1,
HD	X	V6 2.8L Chev Canada	FD2	2095	2.84	37-33	2.53	1,2,3,4
CT	X	V6 2.8L Chev H/O	FJ2	2060	3.33	35-35	3.33	1,3
CL	A,X	V6 2.8L Chev	FD2	2095	2.84	35-35	2.84	1,3
PW	A,X	I4 2.5L Pontiac	FJ2	2060	2.84	38-32	2.39	1,3
PD	A,X	I4 2.5L Pont (Perf)	FJ2	2060	2.84	35-35	2.84	1,3
HM	A,X	V6 2.8L Chev Mexico	FDO*	2095	3.33	35-35	3.33	1,
HP	A,X	V6 2.8L Chev Columbia	FJO*	2060	3.33	35-35	3.33	1,
HS	A,X	V6 2.8L Chev Canada	FD2	2095	2.84	35-35	2.84	1,2,3,4
HN	A	V6 2.8L Chev(Can. Pol.)	FD2	2095	3.06	35-35	3.06	1,
CC	A	V6 2.8L Chev H/O	FJ2	2060	3.33	35-35	3.33	2,
CK	A	V6 2.8L Chev Police	FD2	2095	3.06	35-35	3.06	1,
BL	A	V6 3.0L Buick	FE2	1865	2.84	37-33	2.53	3,
BF	A	V6 3.0L Buick(Altitude)	FE2	1865	3.33	37-33	2.97	3,
HV	A	V6 2.8L Chev Venez H/O	FJO*	2060	3.06	35-35	3.06	1,4
OP	A	V6 4.3L Olds Diesel	FM5	1525	2.84	38-32	2.39	1,3,4
CF	J	I4 2.0L Chev (Altitude)	FK1	2760	3.33	33-37	3.73	1,3
HY	J	I4 2.0L Chev Canada	FK1	2760	2.84	33-37	3.18	1,2,3,4
HC	J	I4 2.0L Chev Canada Alt	FK1	2760	3.06	33-37	3.43	1,2,3,4
PG	J	I4 1.8L Pont OHC/FI	FAL	2795	2.84	33-37	3.18	3,
P3	J	I4 1.8L Pont OHC/FI Alt	FAL	2795	3.33	35-35	3.33	3,
CB	J	I4 2.0L Chev	FK1	2760	2.84	33-37	3.18	1,3
CA	J	I4 2.0L Chev Altitude	FK1	2760	3.06	33-37	3.43	3,4,5
PJ	J	I4 1.8L Pont Turbo	FA2	2795	3.33	35-35	3.33	2,3
PI	P	I4 2.5L Pontiac	FJ2	2060	2.84	35-35	2.84	2,

1984 THM 125C MODELS (Continued)

<u>MODEL</u>	<u>CAR LINE</u>	<u>ENGINE</u>	<u>CONV CODE</u>	<u>STALL SPEED</u>	<u>FINAL DRIVE</u>	<u>SPROCKETS DRIVE-DRIVEN</u>	<u>OVERALL RATIO</u>	<u>USED BY</u>
EF	Opel T	I4 1.3L N Opel	FA0*	2795	3.33	33-37	3.73	
EP	Opel J,T	I4 1.6L D Opel	FA0*	2795	3.33	33-37	3.73	
EK	Opel J,T	I4 1.3L S Opel	FA0*	2795	3.33	33-37	3.73	
EQ	Opel J,T	I4 1.6L S Opel	FC0*	2385	3.33	35-35	3.33	
EI	Opel J	I4 1.8L E Opel	FC0*	2385	3.33	35-35	3.33	
EB	Opel J	I4 1.6L N Opel	FC0*	2385	3.33	33-37	3.73	
EL	Holden J	I4 1.6L S Opel	FB0*	2560	3.33	35-35	3.33	
EM	Isuzu J	I4 2.0L Isuzu	FC1	2385	3.33	35-35	3.33	
EN	Isuzu J	I4 2.0L Isuzu Diesel	FB0	2560	3.33	35-35	3.33	
EW	Isuzu J	I4 2.0L Isuzu Turbo	FD2	2095	3.33	35-35	3.33	

- 1 - Chevrolet
- 2 - Pontiac
- 3 - Oldsmobile
- 4 - Buick
- 5 - Cadillac

* - 1982 and up OPEN converter, that is identical in external appearance to the lock-up converter, but they do not have a clutch inside.

1985 Buick Models

<u>MODEL</u>	<u>CAR LINE</u>	<u>ENGINE</u>	<u>CONV CODE</u>	<u>STALL SPEED</u>	<u>FINAL DRIVE</u>	<u>SPROCKETS DRIVE-DRIVEN</u>	<u>OVERALL RATIO</u>	<u>USED BY</u>
CE	X	V6 2.8L Chev	FD2	2095	2.84	37-33	2.53	1,
CX	A,X	V6 2.8L Chev (PFI)	FJ4	2060	2.84	33-37	3.18	1,2
CT	A,X	V6 2.8L Chev (PFI)	FJ4	2060	2.84	35-35	2.84	1,2
CL	A,X	V6 2.8L Chev	FD2	2095	2.84	35-35	2.84	1,2,3
PW	A,X	I4 2.5L Pont	FJ2	2060	2.84	38-32	2.39	1,2,3
PD	A,X	I4 2.5L Pont (Perf)	FJ2	2060	2.84	35-35	2.84	1,2,3
HM	A,X	V6 2.8L Chev(Mexico)	FD0*	2095	3.33	35-35	3.33	1,
HP	A,X	V6 2.8L Chev(Columbia)	FJ0*	2060	3.33	35-35	3.33	1,6
HS	A,X	V6 2.8L Chev (Canada)	FJ2	2060	2.84	35-35	2.84	1,2,3,4,6
HV	A	V6 2.8L Chev (Can. Pol)	FJ2	2060	3.06	35-35	3.06	1,6
CK	A	V6 2.8L Chev Police	FD2	2095	3.06	35-35	3.06	1,
BL	A	V6 3.0L Buick	FE2	1865	2.84	37-33	2.53	3,4
BF	A	V6 3.0L Buick(Altitude)	FE2	1865	3.33	37-33	2.97	3,4
HX	A	V6 2.8L Chev (Venz H.O.)	FJ0*	2060	3.33	35-35	3.33	1,
OP	A	V6 4.3L Olds Diesel	FM5	1525	2.84	38-32	2.39	1,2,3,4
CJ	J	V6 2.8L Chev (PFI)	FJ4	2060	3.06	35-35	3.06	1,3,6
CB	J	I4 2.0L Chev	FK1	2760	2.84	33-37	3.18	1,2,3,4,6
CI	J	I4 2.0L Chev	FK1	2760	2.84	33-37	3.18	1,2,3,4,6
CA	J	I4 2.0L Chev	FK1	2760	3.06	33-37	3.43	2,3,4,5,6
CC	J	I4 2.0L Chev	FK1	2760	3.06	33-37	3.43	2,3,4,5,6
PG	J	I4 1.8L Pont(OHC/TBI)	FA3	2795	2.84	33-37	3.18	3,4
PE	J	I4 1.8L Pont(OHC/TBI)	FA3	2795	3.06	33-37	3.43	2,3
PJ	J	I4 1.8L Pont (Turbo)	FA2	2795	3.33	35-35	3.33	2,4
PF	P	I4 2.5L Pont (TBI)	FJ2	2060	2.84	33-37	3.18	2,
CD	P	V6 2.8L Chev (PFI)	FJ4	2060	3.06	35-35	3.06	2,6
PN	N	I4 2.5L Pont (TBI)	FZ2	2375	2.84	35-35	2.84	2,3,4
BP	N	V6 3.0L Buick (PFI)	FJ4	2060	2.84	35-35	2.84	2,3,4

1985 THM 125C MODELS (Continued)

<u>MODEL</u>	<u>CAR LINE</u>	<u>ENGINE</u>	<u>CONV CODE</u>	<u>STALL SPEED</u>	<u>FINAL DRIVE</u>	<u>SPROCKETS DRIVE-DRIVEN</u>	<u>OVERALL RATIO</u>	<u>USED BY</u>
EF	Opel	I4 1.3L N Opel	FA0*	2795	3.33	33-37	3.73	
EP	Opel J,T	I4 1.6L D Opel	FA0*	2795	3.33	33-37	3.73	
EK	Opel J,T	I4 1.3L S Opel	FA0*	2795	3.33	33-37	3.73	
EQ	Opel J,T	I4 1.6L S Opel	FC0*	2385	3.06	33-37	3.43	
EI	Opel J	I4 1.8L E Opel	FC0*	2385	3.06	33-37	3.43	
EB	Opel J	I4 1.6L N Opel	FC0*	2385	3.33	33-37	3.73	
EL	Holden J	I4 1.6L S Opel	FB0*	2560	3.33	35-35	3.33	
EM	Isuzu J	I4 2.0L Isuzu	FC1	2385	3.33	35-35	3.33	
EN	Isuzu J	I4 2.0L Isuzu Diesel	FB1	2560	3.33	35-35	3.33	
EW	Isuzu J	I4 2.0L Isuzu Turb-Dsl	FD2	2095	3.33	35-35	3.33	
EC	Isuzu J	I4 2.0L Turbo	FJ2	2060	3.33	35-35	3.33	
EZ	Holden J	I4 1.8L E Opel	FB0*	2560	3.33	35-35	3.33	
EG	Holden J	I4 1.6L N Opel	FC0*	2385	3.33	35-35	3.33	

1 - Chevrolet

2 - Pontiac

3 - Oldsmobile

4 - Buick

5 - Cadillac

6 - Canada

* - 1982 and up OPEN converter, that is identical in external appearance to the lock-up converter, but they do not have a clutch inside.

1986 THM 125C MODELS

<u>MODEL</u>	<u>CAR LINE</u>	<u>ENGINE</u>	<u>CONV CODE</u>	<u>STALL SPEED</u>	<u>FINAL DRIVE</u>	<u>SPROCKETS DRIVE-DRIVEN</u>	<u>OVERALL RATIO</u>	<u>USED BY</u>
CK	A	V6 2.8L Chev Police	FD2B	2095	3.06	35-35	3.06	1
CL	A	V6 2.8L Chevrolet	FD2B	2095	2.84	35-35	2.84	1,2,3
CT	A	V6 2.8L Chev (PFI)	FJ4B	2060	2.84	35-35	2.84	1,2
CU	A	V6 2.8L Chev (MPFI)	FJ4B	2060	2.84	33-37	3.18	1,2,3,4
CX	A	V6 2.8L Chev (PFI)	FJ4B	2060	2.84	33-37	3.18	1,2,3
PD	A	I4 2.5L Pont (Perf)	FJ2B	2060	2.84	35-35	2.84	1,2,3
PW	A	I4 2.5L Pontiac	FJ2B	2060	2.84	38-32	2.39	1,2,3
HS	A	V6 2.8L Chev Canada	FJ2B	2060	2.84	35-35	2.84	1,2,3,4,6
HU	A	V6 2.8L Chev Can Police	FJ2B	2060	3.06	35-35	3.06	1,2,3,4,6
BA	A,N	V6 3.0L Buick (PFI)	FJ4B	2060	2.84	33-37	3.18	3,4
BC	A,N	V6 3.0L Buick (PFI)	FJ4B	2060	2.84	33-37	3.18	3,4
BD	A,N	V6 3.0L Buick (PFI)	FJ4B	2060	2.84	35-35	2.84	3,4
BP	A,N	V6 3.0L Buick (PFI)	FJ4B	2060	2.84	35-35	2.84	3,4
CA	J	I4 2.0L Chevrolet	FK1B	2760	3.06	33-37	3.43	2,3,4,5,6
CB	J	I4 2.0L Chevrolet	FK1B	2760	2.84	33-37	3.18	2,3,4,5,6
CC	J	I4 2.0L Chevrolet	FK1B	2760	3.06	33-37	3.43	2,3,4,5,6
CJ	J	V6 2.8L Chev (PFI)	FJ4B	2060	2.84	33-37	3.18	1,3,6
CM	J	I4 2.0L Chev (TBI)	FK1B	2760	2.84	33-37	3.18	1,2,3,4,5,6
PA	J	I4 2.0L Chev(Turbo PFI)	FA2B	2795	3.33	35-35	3.33	1,3,6
PH	J	I4 1.8L Pont OHC/TBI	FA1B	2795	3.06	33-37	3.43	2,3,4
PJ	J	I4 1.8L Pont Turbo	FA2B	2795	3.33	35-35	3.33	2,4
PK	J	I4 1.8L Pont OHC/TBI	FA1B	2795	2.84	33-37	3.18	1,2,3,4
PN	J	I4 2.5L Pontiac (TBI)	FZ2B	2375	2.84	35-35	2.84	2,3,4
PR	J	I4 1.8L Pont OHC/TBI	FA1B	2795	3.06	33-37	3.43	2,3,4

1986 THM 125C MODELS (Continued)

<u>MODEL</u>	<u>CAR LINE</u>	<u>ENGINE</u>	<u>CONV CODE</u>	<u>STALL SPEED</u>	<u>FINAL DRIVE</u>	<u>SPROCKETS DRIVE-DRIVEN</u>	<u>OVERALL RATIO</u>	<u>USED BY</u>
CD	P	V6 2.8L Chevrolet PFI	FJ4B	2060	3.06	35-35	3.06	2,6
PF	P	I4 2.5L Pontiac TBI	FJ2B	2060	2.84	33-37	3.18	2,

- 1 - Chevrolet
- 2 - Pontiac
- 3 - Oldsmobile
- 4 - Buick
- 5 - Cadillac
- 6 - Canada

1987 THM 125C MODELS

<u>MODEL</u>	<u>CAR LINE</u>	<u>ENGINE</u>	<u>CONV CODE</u>	<u>STALL SPEED</u>	<u>FINAL DRIVE</u>	<u>SPROCKETS DRIVE-DRIVEN</u>	<u>OVERALL RATIO</u>	<u>USED BY</u>
CXC	A	V6 2.8L Chevrolet MPFI	FJ4B	2060	2.84	33-37	3.18	1,2
CTC	A	V6 2.8L Chevrolet MPFI	FJ4B	2060	2.84	35-35	2.84	1,2
HRC	A	V6 2.8L Chev (Venezuela)	FD4B	2095	3.06	33-37	3.43	6,
HLC	A	V6 2.8L Chev (Mexico)	FD0B	2095	3.06	33-37	3.43	1,
PWC	A	I4 2.5L Pontiac TBI	FJ2B	2060	2.84	38-32	2.39	1,2,3,4,6
PDC	A	I4 2.5L Pontiac TBI	FJ2B	2060	2.84	35-35	2.84	1,2,3,4,6
CJC	J	V6 2.8L Chevrolet MPFI	FJ4B	2060	2.84	33-37	3.18	1,3,6
CBC	J	I4 2.0L Chevrolet TBI	FK1B	2760	2.84	33-37	3.18	1,3,4,6
CMC	J	I4 2.0L Chevrolet TBI	FK1B	2760	2.84	33-37	3.18	1,3,6
CAC	J	I4 2.0L Chevrolet TBI	FK1B	2760	3.06	33-37	3.43	1,3,4,5,6
CCC	J	I4 2.0L Chevrolet TBI	FK1B	2760	3.06	33-37	3.43	1,3,5,6
PKC	J	I4 2.0L Pontiac OHC/TBI	FA2B	2795	2.84	33-37	3.18	3,4
PHC	J	I4 2.0L Pontiac OHC/TBI	FA2B	2795	3.06	33-37	3.43	2,3
PFC	J	I4 2.0L Pontiac OHC/TBI	FA2B	2795	3.06	33-37	3.43	2,3
PPC	J	I4 2.0L Pontiac Turbo	FB4B	2560	2.84	33-37	3.18	2,4
CUC	L	V6 2.8L Chevrolet MPFI	FJ4B	2060	2.84	33-37	3.18	1,
CRC	L	I4 2.0L Chevrolet TBI	FK1B	2760	2.84	33-37	3.18	1,
CSC	L	I4 2.0L Chevrolet TBI	FK1B	2760	3.06	33-37	3.43	1,
BPC	N	V6 3.0L Buick MPFI	FJ4B	2060	2.84	35-35	2.84	2,3,4
BDC	N	V6 3.0L Buick MPFI	FJ4B	2060	2.84	35-35	2.84	2,3,4
BHC	N	V6 3.0L Buick MPFI	FJ4B	2060	2.84	37-33	2.53	2,3,4
BJC	N	V6 3.0L Buick MPFI	FJ4B	2060	2.84	37-33	2.53	2,3,4
PNC	N	I4 2.5L Pontiac TBI	FZ2B	2375	2.84	35-35	2.84	2,3,4
PMC	N	I4 2.0L Pontiac Turbo	FB4B	2560	2.84	33-37	3.18	2,
CPC	P	V6 2.8L Chevrolet MPFI	FD4B	2095	3.33	35-35	3.33	2,6
PSC	P	I4 2.5L Pontiac TBI	FJ2B	2060	2.84	35-35	2.84	2,6

1987 THM 125C MODELS (Continued)

<u>MODEL</u>	<u>CAR LINE</u>	<u>ENGINE</u>	<u>CONV CODE</u>	<u>STALL SPEED</u>	<u>FINAL DRIVE</u>	<u>SPROCKETS DRIVE-DRIVEN</u>	<u>OVERALL RATIO</u>	<u>USED BY</u>
PTC	Pont T	I4 1.6L Opel TBI	FA1B	2795	3.06	33-37	3.43	2,
JXC	Holden J	I4 2.0L PFI	FA1B	2795	3.33	35-35	3.33	
JDC	Isuzu J	I4 1.8L N Isuzu	FC1B	2385	3.06	33-37	3.43	
JMC	Isuzu J	I4 2.0L N Isuzu	FC1B	2385	3.33	35-35	3.33	
JNC	Isuzu J	I4 2.0L D Isuzu	FZ1B	2375	3.33	33-37	3.73	
JWC	Isuzu J	I4 2.0L D Isuzu Turbo	FZ1B	2375	3.06	33-37	3.43	
JFC	Opel T	I4 1.3L N Opel	*FA0A	2795	3.33	33-37	3.73	
RAC	Opel T	I4 1.3L TBI Opel	*FA0A	2795	3.33	33-37	3.73	
JPC	Opel J,T	I4 1.6L D Opel	*FA0A	2795	3.33	33-37	3.73	
JKC	Opel J,T	I4 1.3L S Opel	*FA0A	2795	3.33	33-37	3.73	
TAC	Opel J,T	I4 1.6L TBI Opel	*FA0B	2795	3.06	33-37	3.43	
TBC	Opel J,T	I4 1.6L S Opel	*FZ0B	2375	3.06	33-37	3.43	
JAC	Opel J	I4 1.8L S Opel	*FZ0B	2375	3.06	33-37	3.43	
JUC	Opel T	I4 1.8L E Opel	*FZ0B	2375	3.33	35-35	3.33	
RCC	Opel S	I4 2.0L NE Opel	*FJOB	2060	3.33	35-35	3.33	
HZC	Opel J	I4 1.8L N GM Brazil	*FZ0B	2375	3.33	33-37	3.73	
HYC	Opel J	I4 2.0L N GM Brazil	*FA0B	2795	3.33	35-35	3.33	

1 - Chevrolet
 2 - Pontiac
 3 - Oldsmobile

4 - Buick
 5 - Cadillac
 6 - Export

* - 1982 and up OPEN converter, that is identical in external appearance to the lock-up converter, but they do not have a clutch inside.

1988 THM 125C MODELS

MODEL	CAR LINE	ENGINE	CONV CODE	STALL SPEED	FINAL DRIVE	SPROCKETS DRIVE-DRIVEN	OVERALL RATIO	USED BY
LSC	A	V6 2.8L Chev MPFI	FJAB	2060	2.84	35-35	2.84	1
CTC	A	V6 2.8L Chev MPFI	FJAB	2060	2.84	35-35	2.84	1
HRC	A	V6 2.8L Chev MPFI	FD4B	2095	3.06	33-37	3.43	6
HJC	A	V6 2.8L Chev MPFI	FD4B	2095	3.06	33-37	3.43	6
HLC	A	V6 2.8L Chev MPFI	FD0B*	2095	3.06	33-37	3.43	Export
PDC	A	L4 2.5L Pontiac TBI	FJ2B	2060	2.84	35-35	2.84	1,2,3,4,5,6
PZC	A	L4 2.5L Pontiac TBI	FJ2B	2060	2.84	35-35	2.84	1,2,3,4,5,6
CJC	J	V6 2.8L Chev MPFI	FJAB	2060	2.84	33-37	3.18	1,3,6
CBC	J	L4 2.0L Chev TBI	FK1B	2760	2.84	33-37	3.18	1,3,4
CMC	J	L4 2.0L Chev TBI	FK1B	2760	2.84	33-37	3.18	1
PKC	J	L4 2.0L Pont OHC/TBI	FA2B	2795	2.84	33-37	3.18	3,4
PPC	J	L4 2.0L Pont Turbo	FBAB	2560	2.84	33-37	3.18	2
TNC	J	V6 2.8L Chev MPFI	FJAB	2060	2.84	35-35	2.84	1,3
TRC	J	L4 2.0L Pont OHC/TBI	FA1B	2795	2.84	33-37	3.18	2
CUC	L	V6 2.8L Chev MPFI	FJAB	2060	2.84	33-37	3.18	1
CRC	L	L4 2.0L Chev TBI	FK1B	2760	2.84	33-37	3.18	1
BHC	N	V6 3.0L Buick MPFI	FJAB	2060	2.84	37-33	2.53	2,3,4
BJC	N	V6 3.0L Buick MPFI	FJAB	2060	2.84	37-33	2.53	2,3,4
KDC	N	L4 2.3L Quad Four	FZBB	2365	2.84	35-35	2.84	3,4
PNC	N	L4 2.5L Pont TBI	FZ2B	2365	2.84	35-35	2.84	2,3,4
PMC	N	L4 2.5L Pont Turbo	FBAB	2560	2.84	33-37	3.18	2
CPC	P	V6 2.8L Chev MPFI	FDAB	2095	3.33	35-35	3.33	2,6
PSC	P	L4 2.5L Pont TBI	FJ2B	2060	2.84	35-35	2.84	2,6
PTC	Pont T	L4 1.6L Pont TBI	FA1B	2795	3.06	33-37	3.43	2
PRC	Pont T	L4 2.0L Pont OHC/TBI	FA1B	2795	2.84	33-37	3.18	2

1988 THM 125C MODELS (Continued)

<u>MODEL</u>	<u>CAR LINE</u>	<u>ENGINE</u>	<u>CONV CODE</u>	<u>STALL SPEED</u>	<u>FINAL DRIVE</u>	<u>SPROCKETS DRIVE-DRIVEN</u>	<u>OVERALL RATIO</u>	<u>USED BY</u>
JXC	Holden J	L4 2.0L PFI	FA1B	2795	3.33	35-35	3.33	
JDC	Isuzu J	L4 1.8L N Isuzu	FC1B	2385	3.06	33-37	3.43	
JMC	Isuzu J	L4 2.0L N Isuzu	FC1B	2385	3.33	35-35	3.33	
JNC	Isuzu J	L4 2.0L D Isuzu	FZ1B	2365	3.33	33-37	3.73	
JWC	Isuzu J	L4 2.0L D Turbo Isuzu	FZ1B	2365	3.06	33-37	3.43	
RAC	Opel T	L4 1.3L Opel TBI	FA0A*	2795	3.33	33-37	3.73	
JPC	Opel J,T	L4 1.6L D Opel	FA0A*	2795	3.06	33-37	3.43	
JKC	Opel T	L4 1.3L S Opel	FA0A*	2795	3.33	33-37	3.73	
TAC	Opel J,T	L4 1.6L Opel TBI	FA0B*	2795	3.06	33-37	3.43	
TBC	Opel J,T	L4 1.6L S Opel	FZ0B*	2365	3.06	33-37	3.43	
JAC	Opel J,T	L4 1.8L S Opel	FZ0B*	2365	3.06	33-37	3.43	
JUC	Opel J,T	L4 1.8L E Opel	FZ0B*	2365	3.33	35-35	3.33	
RCC	Opel J	L4 2.0L NE Opel	FJ0B*	2060	3.33	35-35	3.33	
HZC	Opel J	L4 2.0L N Brazil(Gas)	FZ0B*	2365	3.33	33-37	3.73	
HYC	Opel J	L4 2.0L N Brazil(Eth)	FA0B*	2795	3.33	35-35	3.33	

1 - Chevrolet
2 - Pontiac
3 - Oldsmobile

4 - Buick
5 - Cadillac
6 - Canada

* - 1982 and up OPEN converter, that is identical in external appearance to the lock-up converter, but they do not have a clutch inside.

1989 THM 125C MODELS

<u>MODEL</u>	<u>CAR LINE</u>	<u>ENGINE</u>	<u>CONV CODE</u>	<u>STALL SPEED</u>	<u>FINAL DRIVE</u>	<u>SPROCKETS DRIVE-DRIVEN</u>	<u>OVERALL RATIO</u>	<u>USED BY</u>
BZC	A	V6 3.3L Buick PFI	FY9B	2095	3.06	37-33	2.73	2,3,4
BYC	A	V6 3.3L Buick PFI	FY9B	2095	3.06	37-33	2.73	2,3,4
HCC	A	V6 3.1L Pont (Export)	*FB0B	2560	3.06	33-37	3.43	
PBS	A	V6 3.1L Pontiac MPFI	FJBB	2060	2.84	33-37	3.18	2
HRC	A	V6 2.8L Chev MPFI	FDAB	2095	3.06	33-37	3.43	6
HJC	A	V6 2.8L Chev MPFI	FDAB	2095	3.06	33-37	3.43	6
CTC	A	V6 2.8L Chev MPFI	FJAB	2060	2.84	35-35	2.84	1
RTC	A	V6 2.8L Chev MPFI	FJAB	2060	2.84	35-35	2.84	
PDC	A	L4 2.5L Pontiac TBI	FJ2B	2060	2.84	35-35	2.84	1,2,3,4
RUC	A	L4 2.5L Pontiac TBI	FJ2B	2060	2.84	35-35	2.84	3,4
CJC	J	V6 2.8L Chev MPFI	FJAB	2060	2.84	33-37	3.18	1,6
TNC	J	V6 2.8L Chev MPFI	FJAB	2060	2.84	35-35	2.84	1
CBC	J	L4 2.0L Chev TBI	FK1B	2760	2.84	33-37	3.18	1,4,6
PPC	J	L4 2.0L Pont Turbo	FAAB	2795	2.84	33-37	3.18	2
TRC	J	L4 2.0L Pont OHC/TBI	FA1B	2795	2.84	33-37	3.18	2
CUC	L	V6 2.8L Chev MPFI	FJAB	2060	2.84	33-37	3.18	1
CRC	L	L4 2.0L Chev TBI	FK1B	2760	2.84	33-37	3.18	1
BUC	N	V6 3.3L Buick PFI	FG9B	1860	2.84	38-32	2.39	2,3,4
PNC	N	L4 2.5L Pontiac TBI	FZ2B	2365	2.84	35-35	2.84	2,3,4
KDC	N	L4 2.3L Quad Four	FZBB	2365	2.84	35-35	2.84	2,3,4
KRC	N	L4 2.3L Quad Four	FKBB	2760	2.84	35-35	2.84	2,3,4
KCC	N	L4 2.3L Quad Four	FKBB	2760	3.06	35-35	3.06	2,3,4
PMC	N	L4 2.0L Pont Turbo	FAAB	2795	2.84	33-37	3.18	2
PRC	Pont T	L4 2.0L Pont OHC/TBI	FA1B	2795	2.84	33-37	3.18	2
PTC	Pont T	L4 1.6L Pontiac TBI	FA1B	2795	3.06	33-37	3.43	2

1989 THM 125C MODELS (Continued)

<u>MODEL</u>	<u>CAR LINE</u>	<u>ENGINE</u>	<u>CONV CODE</u>	<u>STALL SPEED</u>	<u>FINAL DRIVE</u>	<u>SPROCKETS DRIVE-DRIVEN</u>	<u>OVERALL RATIO</u>	<u>USED BY</u>
JDC	Isuzu J	L4 2.0L N Isuzu	FC1B	2385	3.06	33-37	3.43	
JMC	Isuzu J	L4 2.0L N Isuzu	FC1B	2385	3.33	35-35	3.33	
RCC	Opel T	L4 2.0L NE Opel	*FJOB	2060	3.33	35-35	3.33	
JAC	Opel T	L4 1.8L S Opel	*FZOB	2365	3.06	33-37	3.43	
JUC	Opel T	L4 1.8L E Opel	*FZOB	2365	3.33	35-35	3.33	
JYC	Opel T	L4 1.7L D Opel	*FAOA	2795	3.06	33-37	3.43	
TAC	Opel T	L4 1.6L Opel TBI	*FAOB	2795	3.06	33-37	3.43	
TBC	Opel T	L4 1.6L S Opel	*FZOB	2365	3.06	33-37	3.43	
RAC	Opel T	L4 1.3L Opel TBI	*FAOA	2795	3.33	33-37	3.73	
JKC	Opel T	L4 1.3L S Opel	*FAOA	2795	3.33	33-37	3.73	

1 - Chevrolet
 2 - Pontiac
 3 - Oldsmobile

4 - Buick
 5 - Cadillac
 6 - Canada

* - 1982 and up OPEN converter, that is identical in external appearance to the lock-up converter, but they do not have a clutch inside.

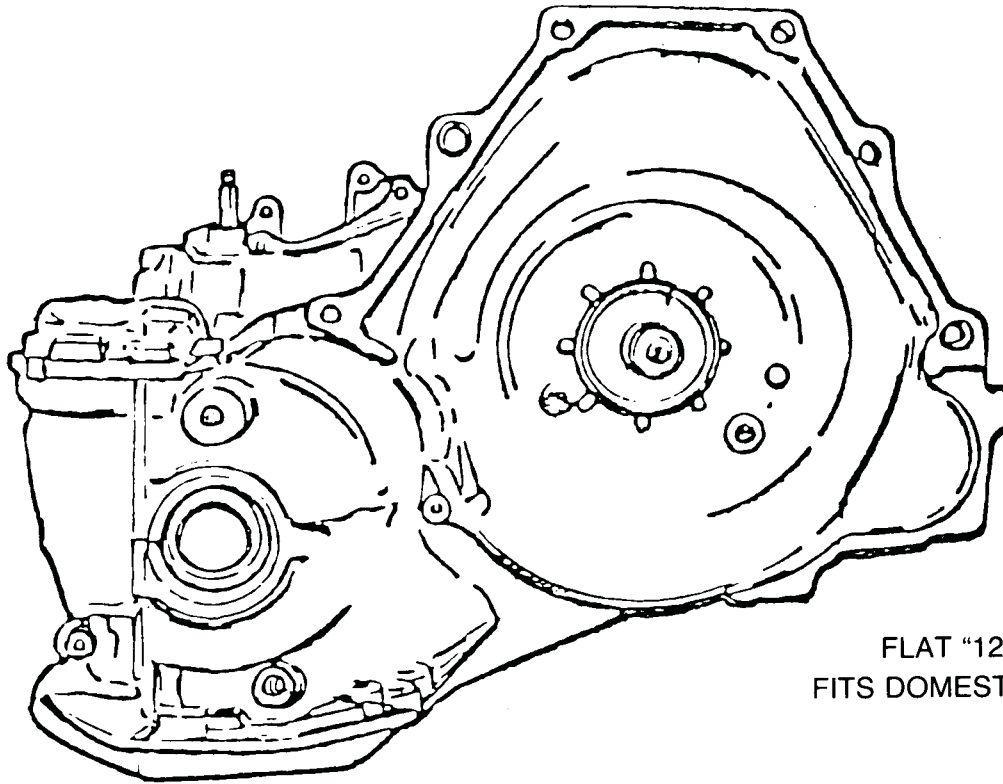

FLAT "125" BELL
FITS DOMESTIC ENGINES

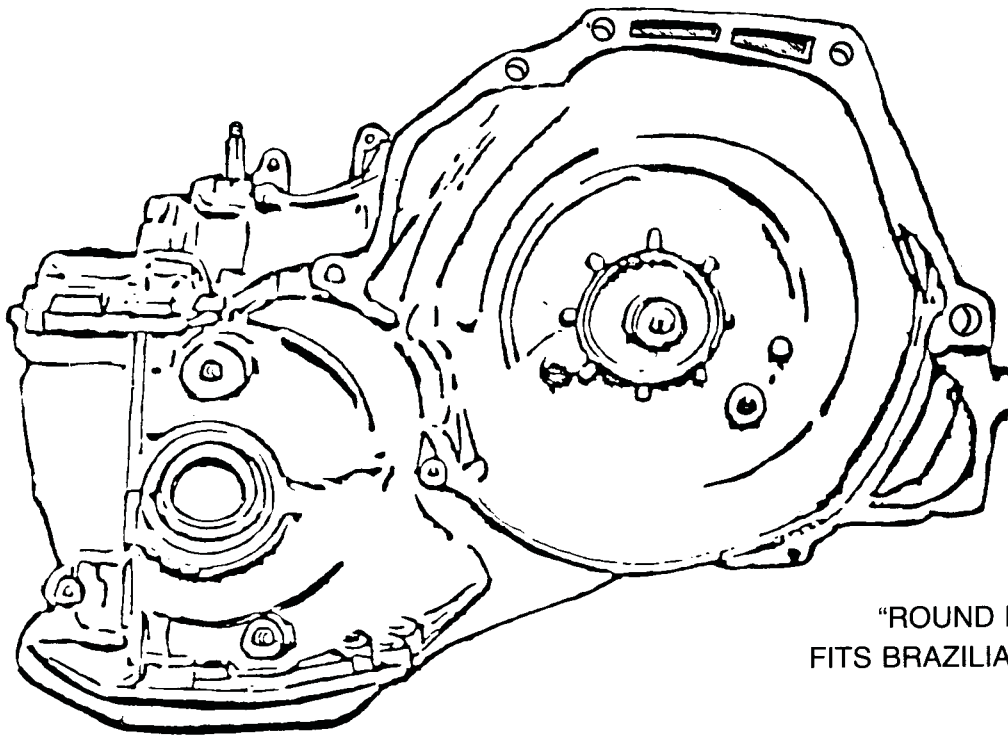

"ROUND BELL"
FITS BRAZILIAN ENGINE