

This is FREE, if you paid for it demand your money back!



<~~~~~ Bookmark links for quick navigation



1997  
THUNDERBIRD  
COUGAR XR7

This is FREE, if you paid for it demand your money back!

**SERVICE MANUAL**

FIX IT RIGHT THE FIRST TIME ON TIME

# TABLE OF CONTENTS

INTRODUCTION

**GROUP 00** SERVICE INFORMATION

**GROUP 01** BODY

**GROUP 02** FRAME AND MOUNTING

**GROUP 03** ENGINE

**GROUP 04** SUSPENSION

**GROUP 05** DRIVELINE

**GROUP 06** BRAKE SYSTEM

**GROUP 07** TRANSMISSION/TRANSAXLE

**GROUP 09** EXHAUST SYSTEM

**GROUP 10** FUEL SYSTEM

**GROUP 11** STEERING SYSTEM

**GROUP 12** CLIMATE CONTROL SYSTEM

**GROUP 13** INSTRUMENTATION AND WARNING SYSTEMS

**GROUP 14** BATTERY AND CHARGING SYSTEM

**GROUP 15** AUDIO SYSTEMS

**GROUP 17** LIGHTING

INDEX





# INTRODUCTION

**NOTE:** The descriptions and specifications contained in this manual were in effect at the time this manual was approved for printing. Ford Motor Company reserves the right to discontinue models at any time, or change specifications or design without notice and without incurring any obligation.

## IMPORTANT SAFETY NOTICE

Appropriate service methods and procedures are essential for the safe, reliable operation of all motor vehicles as well as the personal safety of the individual doing the work. This manual provides general directions for performing service with tested, effective techniques. Following them will help assure reliability.

There are numerous variations in procedure, techniques, tools and parts for servicing vehicles, as well as in the skill of the individual doing the work. This manual cannot possibly anticipate all such variations and provide advice or cautions as to each. Accordingly, anyone who departs from the instructions provided in this manual must first establish that he comprises neither his personal safety nor the vehicle integrity by his choice of methods, tools or parts.

## NOTES, CAUTIONS, AND WARNINGS

As you read through the procedures, you will come across **NOTES**, **CAUTIONS**, and **WARNINGS**. Each one is there for a specific purpose. **NOTES** give you added information that will help you to perform a particular procedure. **CAUTIONS** are given to prevent you from making an error that could damage the vehicle. **WARNINGS** remind you to be especially careful in those areas where carelessness can cause you personal injury. The following list contains some general **WARNINGS** that you should follow when you work on a vehicle.

- **ALWAYS WEAR SAFETY GLASSES FOR EYE PROTECTION.**
- **USE SAFETY STANDS WHENEVER A PROCEDURE REQUIRES YOU TO BE UNDER THE VEHICLE.**
- **MAKE SURE THAT THE IGNITION SWITCH IS ALWAYS IN THE OFF POSITION, UNLESS OTHERWISE REQUIRED BY THE PROCEDURE.**
- **SET THE PARKING BRAKE WHEN WORKING ON THE VEHICLE. IF YOU HAVE AN AUTOMATIC TRANSMISSION, SET IN PARK UNLESS INSTRUCTED OTHERWISE FOR A SPECIFIC OPERATION. IF YOU HAVE A MANUAL TRANSMISSION, IT SHOULD BE IN REVERSE (ENGINE OFF) OR NEUTRAL (ENGINE ON) UNLESS INSTRUCTED OTHERWISE FOR A SPECIFIC OPERATION. PLACE WOOD BLOCKS (4" X 4" OR LARGER) AGAINST THE FRONT AND REAR SURFACES OF THE TIRES TO HELP PREVENT THE VEHICLE FROM MOVING.**
- **OPERATE THE ENGINE ONLY IN A WELL-VENTILATED AREA TO AVOID THE DANGER OF CARBON MONOXIDE POISONING.**
- **KEEP YOURSELF AND YOUR CLOTHING AWAY FROM MOVING PARTS WHEN THE ENGINE IS RUNNING, ESPECIALLY THE DRIVE BELTS.**
- **TO PREVENT SERIOUS BURNS, AVOID CONTACT WITH HOT METAL PARTS SUCH AS THE RADIATOR, EXHAUST MANIFOLD, TAIL PIPE, THREE-WAY CATALYTIC CONVERTER AND MUFFLER.**
- **DO NOT SMOKE WHILE WORKING ON A VEHICLE.**
- **TO AVOID INJURY, ALWAYS REMOVE RINGS, WATCHES, LOOSE HANGING JEWELRY AND LOOSE CLOTHING BEFORE BEGINNING TO WORK ON A VEHICLE.**
- **WHEN IT IS NECESSARY TO WORK UNDER THE HOOD, KEEP HANDS AND OTHER OBJECTS CLEAR OF THE RADIATOR FAN BLADES!**



# GROUP

# 07

# TRANSMISSION

SECTION TITLE	PAGE	SECTION TITLE	PAGE
TRANSMISSION, AUTOMATIC—4R70W .....	07-01-1	TRANSMISSION, AUTOMATIC—EXTERNAL	
TRANSMISSION, AUTOMATIC—COOLING .....	07-02-1	CONTROLS.....	07-05-1

## SECTION 07-01 Transmission, Automatic—4R70W

SUBJECT	PAGE	SUBJECT	PAGE
VEHICLE APPLICATION .....	07-01-2	DISASSEMBLY	
DESCRIPTION AND OPERATION		Transmission.....	07-01-117
4R70W Transmission .....	07-01-2	DISASSEMBLY AND ASSEMBLY OF	
Identification Tags.....	07-01-2	SUBASSEMBLIES	
Main Components and Function.....	07-01-11	Direct Clutch Cylinder.....	07-01-157
Transmission Electronic Control System.....	07-01-17	Forward Clutch Cylinder .....	07-01-147
Transmission Range Selection .....	07-01-9	Intermediate Clutch Cylinder .....	07-01-141
Transmission Shift Patterns .....	07-01-10	Main Control Valve Body .....	07-01-131
DIAGNOSIS AND TESTING		Output Shaft and Direct Clutch Cylinder .....	07-01-155
After On-Board Diagnostics .....	07-01-31	Planetary Gear Support Assembly and	
Before Pinpoint Tests .....	07-01-31	Planetary Low One-Way Clutch .....	07-01-152
Diagnosis By Symptom Routines.....	07-01-76	Pump and Intermediate Clutch Piston—	
Diagnostic Flow Chart .....	07-01-23	Disassembly.....	07-01-136
Diagnostic Routines.....	07-01-77	Pump and Intermediate Clutch	
Diagnostic Strategy .....	07-01-21	Piston— Assembly .....	07-01-138
Diagnostics .....	07-01-28	Reverse Clutch .....	07-01-142
Electrical Schematics .....	07-01-43	Reverse Sun Gear Assembly .....	07-01-154
Special Testing Procedures.....	07-01-69	Service Notes .....	07-01-130
Know/Understand The Concern .....	07-01-24	Torque Converter Checks .....	07-01-163
Leakage Inspection .....	07-01-72	Torque Converter Leakage Check .....	07-01-163
On-Board Diagnostic Trouble Code Description		ASSEMBLY	
Chart.....	07-01-32	Transmission .....	07-01-167
On-Board Diagnostics With NGS.....	07-01-28	INSTALLATION	
Preliminary Inspection .....	07-01-24	Transmission .....	07-01-179
Rotunda Transmission Tester.....	07-01-36	CLEANING AND INSPECTION	
Transmission Fluid Condition Check .....	07-01-25	Case.....	07-01-181
Transmission Fluid Cooler .....	07-01-75	Converter and Cooler .....	07-01-180
Transmission Fluid		Electrical Connectors.....	07-01-181
Cooler—Backflushing/Cleaning.....	07-01-75	Forward, Direct, Intermediate, Overdrive and	
Verification of Condition .....	07-01-24	Reverse Clutches .....	07-01-181
IN-VEHICLE SERVICE		Main Control Valve Body .....	07-01-180
Electronic Pressure Control (EPC)		One-Way Clutch .....	07-01-181
Solenoid .....	07-01-103	Output Shaft .....	07-01-181
Extension Housing Seal, Gasket and		Planet Assemblies .....	07-01-181
Bushing.....	07-01-98	Thrust Bearings .....	07-01-182
Fluid Cooler Tubes.....	07-01-115	Transmission .....	07-01-180
Main Control Components .....	07-01-106	Transmission Fluid	
Main Control Valve Body .....	07-01-99	Cooler—Backflushing/Cleaning.....	07-01-181
Manual Control Lever Shaft Seal .....	07-01-112	SPECIFICATIONS	
Transmission Fluid Drain and Refill.....	07-01-97	Checks and Adjustments .....	07-01-182
Transmission Range (TR) Sensor.....	07-01-115	SPECIAL SERVICE TOOLS/EQUIPMENT .....	07-01-184
Vehicle Speed Sensor (VSS).....	07-01-98		
REMOVAL			
Transmission .....	07-01-116		

**VEHICLE APPLICATION**

Thunderbird, Cougar

**DESCRIPTION AND OPERATION****4R70W Transmission**

The 4R70W transmission has the following features:

- four speeds
- rear wheel drive
- electronic shift
- torque converter clutch control
- line pressure controls

**Automatic Transmission**

The transmission uses a Ravigneaux-style double-pinion compound gearset to produce four forward speeds and reverse. Two bands, two one-way roller clutches and four friction clutches are used to hold or drive various planetary gearset members.

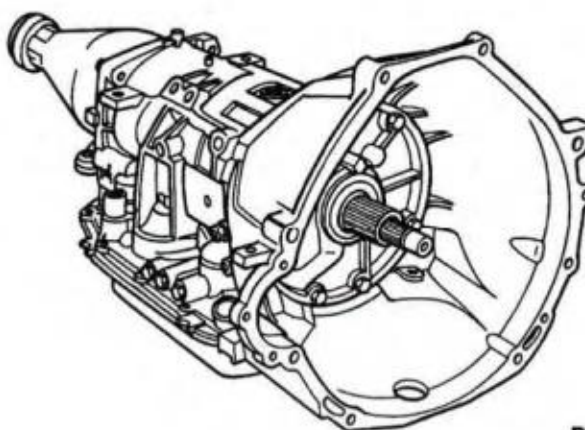
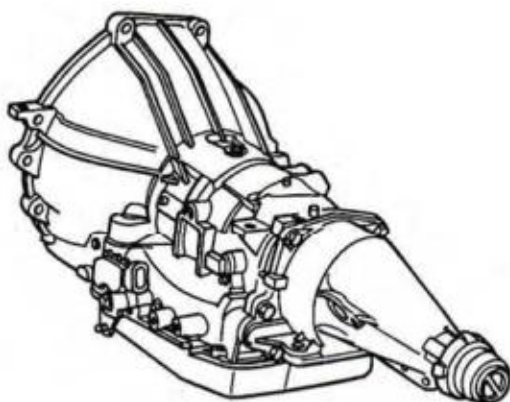

D10217-B

**Identification Tags**

All vehicles are equipped with a vehicle certification label, affixed to the LH (driver's) side door lock post.

Refer to the code in the space marked TR on the vehicle certification label for proper transmission identification.

For additional information such as: model, service identification level or build date, refer to the transmission service identification tag which is attached to transmission case (7005).

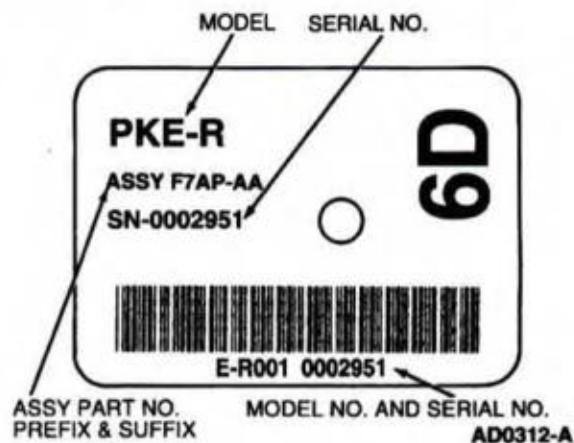
**Typical Transmission Service Identification Tag**

## DESCRIPTION AND OPERATION (Continued)

Transmission, Chassis-mounted Type

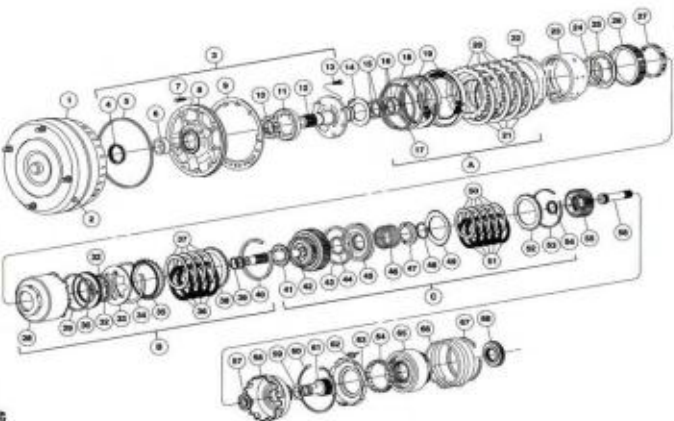

4R70W-1A

## DESCRIPTION AND OPERATION (Continued)

Transaxle, Automatic, Disassembled View (Continued)

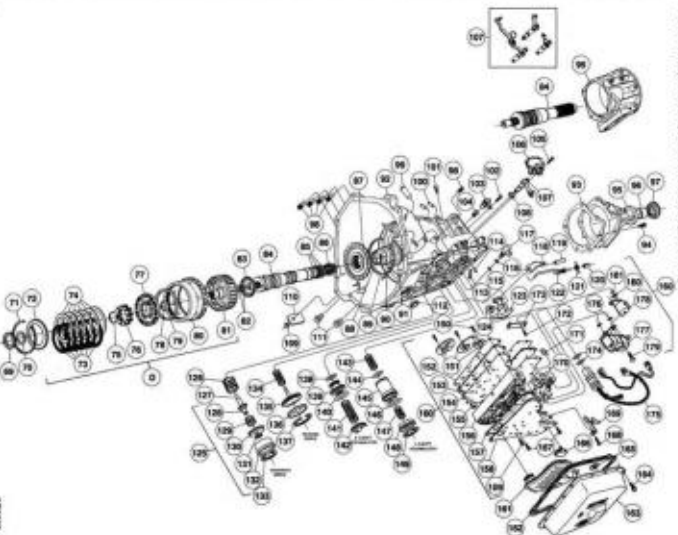

## DESCRIPTION AND OPERATION (Continued)

Item	Part Number	Description
1	7902	Converter Assy
2	87650-S2	Plug - Converter Drain - 1/8-27 Dryseal
3	7A103	Pump Assy - Front
4	7A248	Seal Assy - Front Pump
5	7A248	Seal - Front Pump
6	7B258	Bushing - Front Pump
7	N605789-S100	Bolt - M8-1.25 X 35 Hex Head (7-Attach 7A103 to 7005)
8	7A106	Body Assy - Front Pump (Part of 7A103)
9	7A136	Gasket - Front Pump
10	7H169	Gear - Pump Inner Gerotor (Part of 7A103)
11	7H169	Gear - Pump Outer Gerotor (Part of 7A103)
12	7A108	Support Assy - Front Pump
13	N605787-S	Bolt - M8-1.25 X 25 Hex Fig Head (5-Attach 7A108 to 7A103)
14	7D014	Washer - Front Pump Support Thrust - Select Fit No.1
15	7D020	Seal - Reverse Clutch Cylinder (2 Req'd)
16	7D019	Seal - Forward Clutch Cylinder (2 Req'd)
17	7F225	Seal - Intermediate Clutch Piston - Inner
18	7F224	Seal - Intermediate Clutch Piston - Outer
19	7E005	Piston Kit - Intermediate Clutch
20	7B442	Plate - Intermediate Clutch External Spline (Select Fit) (Steel)
21	7B164	Plate Assy - Intermediate Clutch Internal Spline (Friction)
22	7B066	Plate - Intermediate Clutch Pressure
23	7F196	Band Assy - Overdrive
24	391267-S	Ring - 3-21/64 Retains Type SU External (Retains 7F262 to 7F215)
25	7D191	Retainer - Intermediate One-Way Clutch
26	7F221	Hub - Intermediate Clutch
27	7A089	Clutch Assy - Intermediate One-Way
28	7D044	Drum Assy - Reverse Clutch
29	7D403	Seal - Reverse Clutch Piston - Outer
30	7D402	Piston Assy - Reverse Clutch

(Continued)

Item	Part Number	Description
31	7D404	Seal Reverse Clutch Piston - Inner
32	7D256	Ring - Reverse Clutch Piston Pressure
33	7B070	Spring - Reverse Clutch Piston Return
34	7A577	Spring - Reverse Clutch Piston Spring
35	7B066	Plate - Reverse Clutch Front Pressure
36	7B164	Plate - Reverse Clutch Internal Spline (Friction)
37	7B442	Plate - Reverse Clutch External Spline (Steel)
38	7B066	Plate - Reverse Clutch Rear Pressure
39	7B497	Seal - Input Shaft (2 Req'd)
40	7D483	Retainer - Reverse Clutch Pressure Plate - (Select Fit)
41	7A166	Bearing and Race Assy - Forward Clutch No.2
42	7F207	Cylinder and Input Shaft Assy - Forward Clutch
43	7A548	Seal - Forward Clutch Piston - Outer
44	7C099	Seal - Forward Clutch Piston - Inner
45	7A262	Piston - Forward Clutch
46	7A480	Spring - Forward Clutch Piston Return
47	7A527	Retainer Return Spring - Forward Clutch
48	388099-S	Snap Ring - Retaining - 1-59/64 (Retains 7A529 in 7F207)
49	7E085	Spring - Rear Clutch Pressure Plate
50	7B442	Plate - Forward Clutch External Spline (Steel)
51	7B164	Plate - Forward Clutch Internal Spline (Friction)
52	7B066	Plate - Forward Clutch Pressure
53	7D483	Snap Ring - Retaining (Select Fit)
54	7F231	Bearing and Race Assy - Forward Clutch - Front No.3
55	7B067	Hub - Forward Clutch
56	7F351	Shaft - Intermediate Stub
57	7C096	Bearing and Race Assy - Forward Clutch Hub No.4
58	7A019	Gear Assy - Reverse Sun
59	7F244	Bearing and Race Assy - Forward Clutch Sun Gear No.5

(Continued)

## DESCRIPTION AND OPERATION (Continued)

Item	Part Number	Description
60	388501-S	Retaining Ring - Center Support - 7-7/92
61	7A399	Gear Assy - Forward Clutch Sun
62	7F277	Spring - Case to Planet Support
63	7A130	Support Assy - Planetary Gear
64	7A089	OWC Cage Spring and Roller Assy - Planetary
65	7A398	Planetary Assy
66	7D095	Band Assy - Reverse
67	377437-S	Retaining Ring - 0.58 Thick (Locates Reverse Band During Assy)
68	7F236	Hub - Direct Clutch
69	7F243	Bearing and Race Assy - Direct Clutch Inner No.7
70	7F237	Support - Direct Clutch Inner Bearing
71	7D483	Retaining Ring - Direct Clutch Pressure Plate (Select Fit)
72	7B066	Plate - Direct Clutch Pressure
73	7B164	Plate - Direct Clutch Internal Spline (Friction)
74	7B442	Plate - Direct Clutch External Spline (Steel)
75	388104-S	Retaining Ring - 1-19/32 (Retains 7F235 to 7F283)
76	7F235	Retainer and Spring Assy - Direct Clutch
77	7A262	Piston Assy - Direct Clutch
78	7C099	Seal - Direct Clutch Piston - Inner
79	7A233	Seal - Direct Clutch Piston - Outer
80	7A153	Gear - Output Shaft Ring
81	7F283	Cylinder Assy - Direct Clutch
82	7F274	Seal - Output Shaft Small - Direct Clutch (2 Req'd)
83	7F240	Bearing and Race Assy - Direct Clutch Outer No.8
84	7060	Shaft Assy - Output
85	7F273	Seal - Output to Case Shaft Large (3 Req'd)
86	87054-S94	Seal - O-Ring (Piloted Output Shaft Only)
87	7D164	Hub - Output Shaft
88	97713-S	Snap Ring - 1-13/16 Retaining (Retains 7D164 to 7060)
89	7C122	Snap Ring - Retaining (Retains 7D164 to 7A153)

(Continued)

Item	Part Number	Description
90	7025	Bushing - Rear Case
91	7F242	Bearing and Race Assy - Case Rear No.9
92	7005	Case Assy
93	7086	Gasket - Extension
94	N803747-S1101	Bolt - M8-1.25 X 30 (6-Attach 7A039 to 7005)
95	7A039	Extension Assy
96	7A034	Bushing - Extension Housing
97	7052	Seal Assy - Extension Housing
98	390318-S100	Pipe Plug - 1/8-27 Dryseal Tapered (5 Req'd)
99	7F295	Pin - Overdrive Band Anchor
100	388142-S	Pin - Reverse Band Anchor (Part of 7005)
101	7034	Vent Assy - Case
102	N605771-S427	Bolt - M6-1.0 X 14 Hex Flg Head (Attaches Output Shaft Speed Sensor to Case)
103	7H103	Sensor Assy - Transmission Output Shaft Speed
104	7Z101	Seal - 14.0 X 1.78 O-Ring (2 Req'd)
105	N806933-S102	Bolt and Washer Assy - M6-1.0 X 25MM (2-Attach 7F293 to 7005)
106	7A247	Sensor - Transmission Range
107	7A256	Lever Assy - Manual Control
108	7B498	Seal Assy - Manual Control Lever
109	373907-S2	Nut - 1/4 Spring (Retains Identification Tag to 7000)
110	7B148	Tag - Identification (Part of 7005)
111	7D273	Connector Assy - Fluid Tube (2 Req'd)
112	7N171	Plug - Converter Housing Access
113	7E242	Screen Assy - Fluid
114	7B210	Pin - Manual Lever Shaft Retainer
115	7Z383	Seal - 0.426 X 0.070 O-Ring
116	7Z101	Seal - 14.0 X 1.78 O-Ring
117	7G383	Solenoid Valve - Transmission Pressure Control
118	7A441	Pawl - Parking Pawl
119	7D071	Shaft - Parking Pawl
120	7D419	Cup - Park Rod Guide (Part of 7A039)
121	7D070	Spring - Parking Pawl Return

(Continued)

## DESCRIPTION AND OPERATION (Continued)

Item	Part Number	Description
122	7A232	Rod Assy - Park Pawl Actuating
123	7A115	Lever Assy - Manual Valve Detent Lever
124	N800287-S536	Nut - M14 X 1.5 Hex - Intermediate Detent Lever (Attaches 7A115 to 7A256)
125	7H188	Piston Assy - Overdrive Servo
126	7F201	Spring - Overdrive Servo Piston
127	7F203	Rod - Overdrive Servo Actuating (Part of 7H188)
128	7H179	Washer - Backup Overdrive Servo (Part of 7H188)
129	7G277	Spring - Overdrive Cushion Spring (Part of 7H188)
130	7F200	Piston Assy - Overdrive Servo (Part of 7H188)
131	97411-S	Ring - Retaining (Part of 7H188)
132	7F411	Sleeve Assy - Overdrive Servo (Part of 7H188)
133	7384	Ring - 2.85 Retaining Type TVP "H" Internal (Retains 7H188 to 7005)
134	7D031	Spring - Reverse Band Servo Piston
135	7D189	Piston Assy - Reverse Band Servo
136	7D036	Cover Assy - Reverse Band Servo Piston
137	388215-S100	Retaining Ring - Internal - 3-13/16
138	7F250	Seal - 2-3 Accumulator Piston - Upper
139	7F251	Piston - 2-3 Shift Accumulator
140	7F249	Seal - 2-3 Accumulator Piston - Lower
141	7F285	Spring - 2-3 Shift Accumulator Piston
142	7B264	Retainer - 2-3 Shift Accumulator Spring
143	7F284	Spring - 1-2 Shift Accumulator (Model Dependent)
144	7F248	Seal - 1-2 Shift Accumulator Piston
145	7F251	Piston - 1-2 Shift Accumulator
146	7F249	Seal - 1-2 Shift Accumulator Piston - Lower
147	7F284	Spring - 1-2 Shift Accumulator

(Continued)

Item	Part Number	Description
148	7H300	Cover and Seal Assy - 1-2 Accumulator
149	7384	Ring - 2-1/16 Retaining Type HU Internal (Retains 7H300 to 7005)
150	N807178-S1000	Bolt - M6-1.0 X 16 Hex Head (12-Attach Reinforcing Plate to Valve Body)
151	7F282	Plate - Valve Body Reinforcing (Part of 7A100)
152	7C155	Gasket - Valve Body Separator - Upper
153	7A008	Plate - Control Valve Body Separator (Part of 7A100)
154	7D100	Gasket - Valve Body Separating - Lower
155	7H171	Valve - Converter Drainback
156	7A091	Body Assy - Main Control
157	7H173	Gasket - Valve Body Cover Plate
158	7C034	Plate - Valve Body Cover (Part of 7A100)
159	N807178-S1000	Bolt - M6-1.0 X 18 Hex Head (11-Attach 7C034 to 7A100)(Part of 7A100)
160	7A100	Control Assy - Main
161	7A098	Filter and Seal Assy - Fluid
162	7A191	Gasket - Transmission Pan
163	7A194	Pan - Transmission
164	N605785-S427	Bolt - M8-1.25 X 18 Hex Flg Head (14-Attach 7A194 to 7005)
165	7L027	Magnet - Ceramic Case (Part of 7A194)
166	7H141	Sensor - Transmission Fluid Temperature
167	N808947-S1300	Bolt - M8-1.25 X 46 Hex Shldr Pilot (2-Attach 7C034 to 7A100)
168	N807179-S1000	Bolt - M6-1.0 X 52 Hex Flg Head (12-Attach 7A100 to 7005)
169	7H111	Retainer - Solenoid
170	7E195	Ball - 1/4 Diameter Coast Booster Valve Shuttle (8 Req'd)
171	7H187	Screen - Solenoid Pressure Supply
172	N606022-S1000	Bolt - M6-1.0 X 40 Hex Flg Head (13-Attach 7A100 to 7005)
173	7E332	Spring Assy - Manual Valve Detent
174	7Z276	Seal - 0.864 X 0.070 O-Ring (2 Req'd)

(Continued)

## DESCRIPTION AND OPERATION (Continued)

Item	Part Number	Description
175	7G276	Bulkhead Assy - Wiring Connector
176	7Z484	Seal - 6.07 x 1.70 O-Ring (2 Req'd)
177	7G484	Solenoid Valve - Transmission Shift
178	7G136	Solenoid Valve - Transmission Torque Converter Clutch

(Continued)

Item	Part Number	Description
179	N807178-S1000	Bolt - M6-1.0 X 16 Hex Head (Retains 7G136 & 7G484 to 7A100)
180	7Z136	Seal - 0.489 x 0.070 O-Ring
181	7Z484	Seal - 0.176 x 0.070 O-Ring
A	—	Intermediate Clutch Assy
B	—	Reverse Clutch Assy
C	—	Forward Clutch Assy
D	—	Direct Clutch Assy

## Bushings, Bearing and Thrust Washer Locator

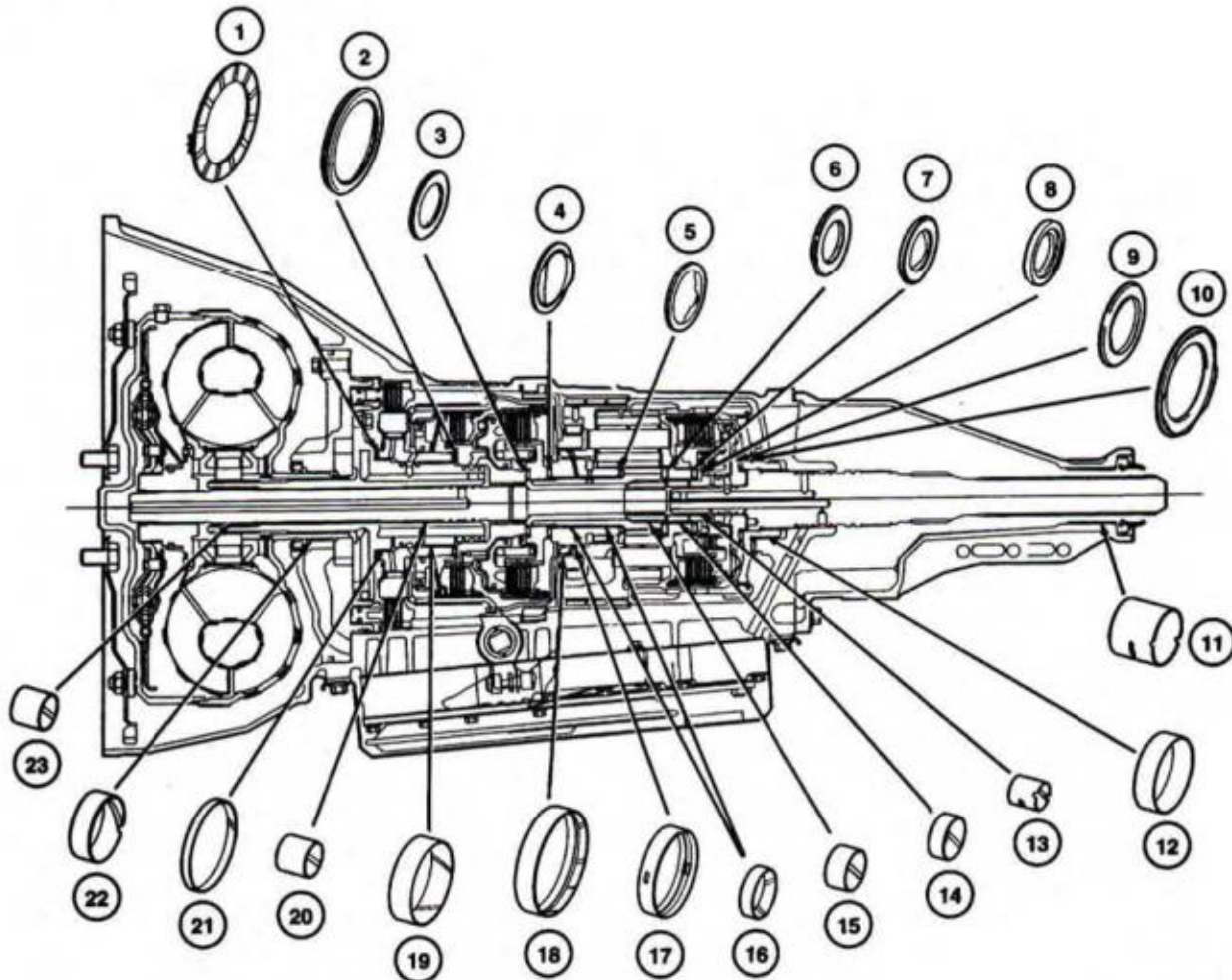

D15803-A

## DESCRIPTION AND OPERATION (Continued)

Item	Part Number	Description
1	7D014	Pump Assy Thrust Washer (Select Fit)
2	7A166	Forward Clutch Bearing and Race Assy
3	7F231	Forward Clutch Front Bearing and Race Assy
4	7F244	Forward Clutch Sun Gear Bearing and Race Assy
5	7F244	Forward Clutch Sun Gear Bearing and Race Assy
6	7F241	Planetary Bearing and Race Assy
7	7F243	Direct Clutch Inner Bearing and Race Assy
8	7F237	Direct Clutch Inner Bearing Support No. 7
9	7F240	Direct Clutch Outer Bearing and Race Assy
10	7F242	Outer Race Bearing and Race Assy

(Continued)

Item	Part Number	Description
11	7A034	Extension Bushing
12	7025	Case Bushing
13	7B233	Output Shaft Bushing
14	7B375	Rear Planetary Carrier Bushing
15	7F209	Forward Clutch Sun Gear Bushing
16	7N193	Reverse Clutch Sun Gear Bushing
17	7B374	Front Carrier Bushing
18	7A132	Planetary Support Bushing
19	—	Reverse Clutch Drum Rear Bushing
20	7B261	Front Drum Support Bushing
21	7F217	Reverse Clutch Drum Front Bushing
22	7B258	Front Pump Bushing
23	7B261	Front Pump Support Bushing

**Transmission Range Selection**

The transmission range selector lever has six positions: P,R,N, , 2 and 1.



TRANSMISSION  
SELECTOR  
INDICATOR

D10222-C

**Park**

- There is no powerflow through the transmission in PARK range.
- The parking pawl (7A441) locks the output shaft (7060) to the case (7005) to prevent the vehicle from rolling.
- For safety reasons, the vehicle parking brake control (2780) should also be used when the vehicle is parked and not in use.
- The engine can be started in the PARK range.
- PARK must be selected before the ignition key can be removed.

**Reverse**

- Reverse gear enables the vehicle to be operated in a rearward direction, at a reduced ratio.
- There is engine braking in REVERSE.

**Neutral**

- There is no powerflow through the transmission in NEUTRAL.
- Wheels are free to move because the output shaft is not held by the parking pawl.
- The engine may be started in NEUTRAL.
- Ignition key cannot be removed while the vehicle is in this range.

**Overdrive**

Overdrive is the normal selector position for most forward driving conditions. This position provides:

- automatic shifts (first through fourth).
- application and release of the torque converter clutch.
- maximum fuel economy during normal operation.

**Manual 2**

Selection of the second gear position (2) provides second gear start and hold.

- Application of the torque converter clutch may also occur in this range, depending on transmission and vehicle conditions.
- This position can be selected when starting on slippery roads for improved traction, or engine braking.

**DESCRIPTION AND OPERATION (Continued)****Manual 1**

Selection of manual 1 or manual low position at idle will allow first gear operation only (no upshifts).

- If this position is selected at normal road speeds, the transmission will initially downshift into second gear, then downshift into first gear when vehicle speed falls below approximately 45 km/h (28 mph).
- The manual low position will provide engine braking, making it especially useful for descending steep grades.

**Transmission Shift Patterns****Upshifts**

Transmission upshifting is controlled by the powertrain control module (PCM)(12A650). The PCM receives inputs from various engine or vehicle sensors and driver demands to control shift scheduling, shift feel and torque converter clutch operation.

**Downshifts**

Under certain conditions the transmission will downshift automatically to a lower gear range (without moving the transmission range selector lever). There are three categories of automatic downshifts: coastdown, torque demand and forced or kickdown shifts.

**Coastdown**

The coastdown downshift occurs as the name indicates; when the vehicle is coasting down to a stop.

**Torque Demand**

The torque demand downshift occurs (automatically) during part throttle acceleration when the demand for torque is greater than the engine can provide at that gear ratio. The transmission will disengage the torque converter clutch to provide added acceleration, if applied.

**Kickdown**

For maximum acceleration, the driver can force a downshift by pressing the accelerator pedal to the floor. A forced downshift into a lower gear (third, second or first) is possible below calibrated speeds. For all shift speed, specifications are subject to variations due to tire size, engine and transmission calibration requirements.

**Transmission Control Switch and Lamp Operation**

The transmission control switch is a momentary contact switch. When the switch is pressed, a signal is sent to the powertrain control module to allow automatic shifts from first through fourth gears or first through third gears only. The PCM energizes the transmission control indicator lamp (TCIL) when the switch is off. The TCIL indicates overdrive cancel mode activated (lamp ON) and EPC circuit shorted (lamp flashing) or monitored sensor failure.

**DESCRIPTION AND OPERATION (Continued)**

**Main Components and Function**

**Transmission Main Components—Sectional View**

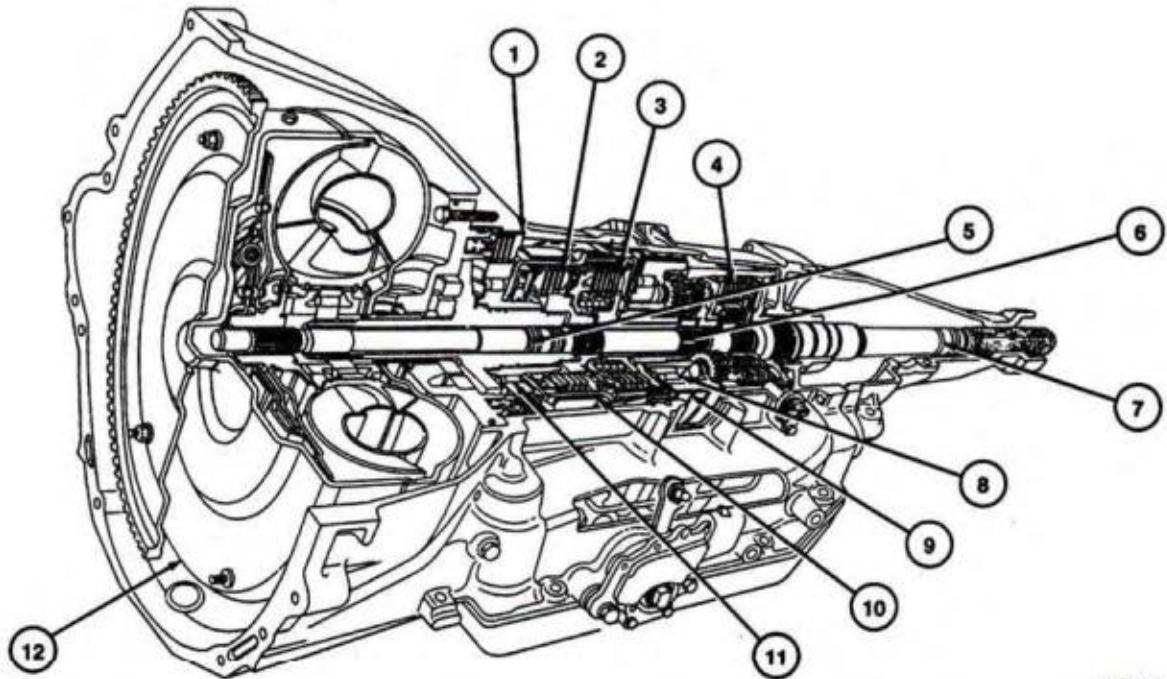

D14697-B

Item	Part Number	Description
1	7B164A	Intermediate Clutch
2	7B164E	Reverse Clutch
3	7B164D	Forward Clutch
4	7B164B	Direct Clutch
5	7F207	Forward Clutch Cylinder and Input Shaft Assy
6	7F351	Stub Shaft

(Continued)

Item	Part Number	Description
7	7060	Output Shaft
8	7A089	Planetary One-Way Clutch
9	7D095	Reverse Clutch Band
10	7F196	Overdrive Band
11	7A089	Intermediate One-Way Clutch
12	7902	Torque Converter

**Torque Converter**

The transmission uses a pressure plate-style torque converter (7902).

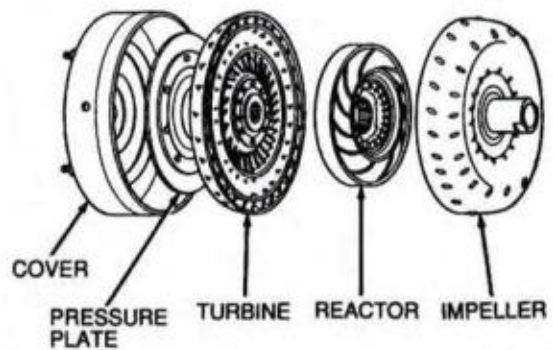

D10218-B

## DESCRIPTION AND OPERATION (Continued)

The torque converter for the transmission is a four-element converter. It contains the standard three elements which transmit and multiply torque:

- impeller
- turbine
- stator

Plus a torque converter clutch for increased fuel economy in third and fourth gears.

The operation of the torque converter components is as follows:

- Rotation of the converter housing and impeller set the fluid in motion.
- The turbine reacts to the fluid motion from the impeller, transferring rotation to the geartrain.
- The stator redirects fluid going back into the impeller, allowing for torque multiplication.

The addition of a torque converter clutch to the torque converter provides a mechanical link between the converter housing and the engine, allowing for direct transfer of power from the engine to the geartrain.

The converter clutch pressure plate (7B066) is applied and released by fluid pressure, which is controlled by the powertrain control module (PCM)(12A650) through an electronic pressure control (EPC) solenoid in the main control valve body (7A100).

### Impeller and Cover

The primary functions of the impeller and cover assembly are to drive the impeller blades, contain hydraulic fluid and provide a mating surface for the converter clutch pressure plate. In addition, the impeller hub drives the fluid pump gear.

### Turbine

The turbine is a sectioned, donut-shaped steel stamping that is splined to the input shaft. It is driven by fluid from the impeller and transmits this power to the geartrain. Because of its basic shape, the turbine automatically directs fluid back to the impeller.

### Reactor

The stator, also called the reactor redirects the fluid flow returned to the impeller from the turbine so that the fluid moves in the same direction as engine / impeller rotation. This action aids in torque multiplication because it adds torque to that already supplied by the engine. The stator contains a one-way clutch which holds it stationary when torque multiplication is necessary, but allows freewheeling at higher speeds when torque multiplication is not necessary.

### Torque Converter Clutch

The pressure plate attaches to the back of the turbine and can be applied against the cover to allow for a mechanical transfer of engine torque to the geartrain. This occurs mainly in third and fourth gears when torque multiplication is no longer necessary. (Converter clutch application may also occur in second gear under certain conditions.)

The pressure plate works much like a regular mechanical clutch. Apply, release and controlled slip of the clutch are controlled by opposing fluid forces on each side of the pressure plate.

### Torque Converter—Sectional View

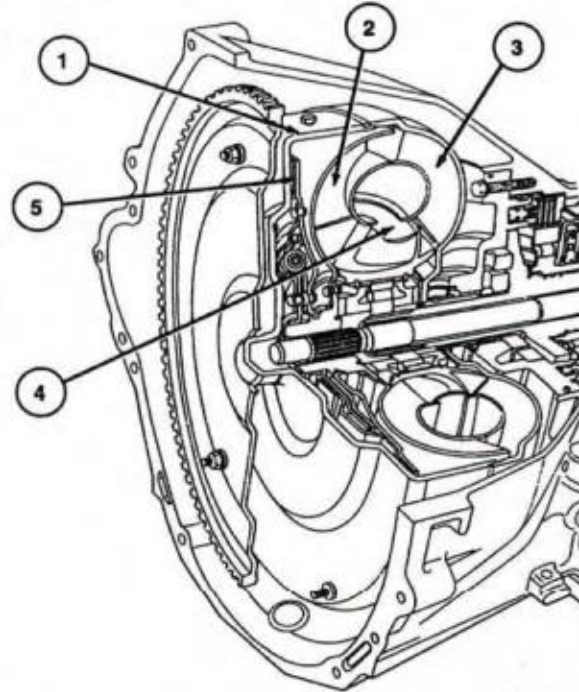

D11472-A

Item	Part Number	Description
1	—	Torque Converter Cover (Part of 7902)
2	—	Turbine (Part of 7902)
3	—	Impeller (Part of 7902)
4	—	Stator (Part of 7902)
5	—	Torque Converter Clutch (Part of 7902)

### Geartrain

Power is transmitted from the torque converter to the Ravigneaux geartrain components through the input shaft and forward clutch cylinder and shaft (7F207).

- The geartrain contains a compound planetary set connected by dual pinion gears.
- By holding or driving certain members of the gearset, four forward ratios and one reverse ratio are obtained and transmitted to the output shaft (7060). The ratios are as follows:

Gear Ratios	
1st gear	2.84 to 1
2nd gear	1.55 to 1

(Continued)

**DESCRIPTION AND OPERATION (Continued)**

Gear Ratios	
3rd gear	1.00 to 1
4th gear	0.70 to 1
Reverse	2.32 to 1

- Members of the gearset are held or driven by a series of bands or clutches.
- The transmission uses:
  - two bands.
  - two one-way roller clutches.
  - four friction clutches.

**Planetary Gearset**

The planetary gearset in the transmission is a Ravigneaux-type set consisting of the following components:

- primary sun gear (7A399)
- reverse clutch gear and shell (7A019).
- a pinion carrier
- long and short pinions
- ring gear (7A153)

Members are driven or held to produce four forward gear ratios plus one reverse ratio.

**Input Shaft**

The forward clutch cylinder and shaft transfers speed and torque from the converter turbine to the geartrain. This forward clutch cylinder and shaft is splined to the turbine shaft (7F351) on one end and to the forward sun gear and turbine shaft on the other end.

**Stub Shaft**

The stub shaft transfers power from the turbine shaft to the planet carrier (through the direct clutch) during third and fourth gear operation.

**Output Shaft**

The output shaft provides torque to the propeller shaft and rear axle assembly (4200). It is driven by the ring gear of the planetary gearset.

**Forward Clutch Cylinder and Shaft**

The forward clutch cylinder and shaft transfers speed and torque from the converter turbine to the geartrain. This shaft is splined to the turbine on one end and to the forward clutch cylinder and stub shaft on the other end.

**Apply Components**

There are eight apply devices used to drive or hold the planetary gearset members. The following is a description of each apply component.

**Band—Overdrive**

The overdrive band holds the reverse clutch drum stationary in fourth gear and in manual range second gear. This action causes the reverse sun gear to be held in these ranges.

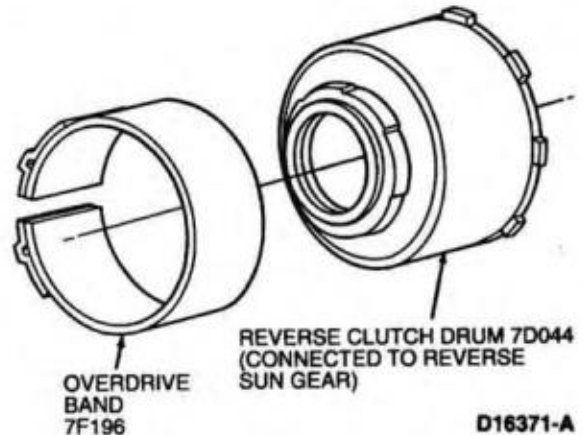
**Band—Low and Reverse**

The low and reverse band holds the pinion carrier stationary in reverse. It is also applied in first gear, manual 1 range, to provide engine braking.

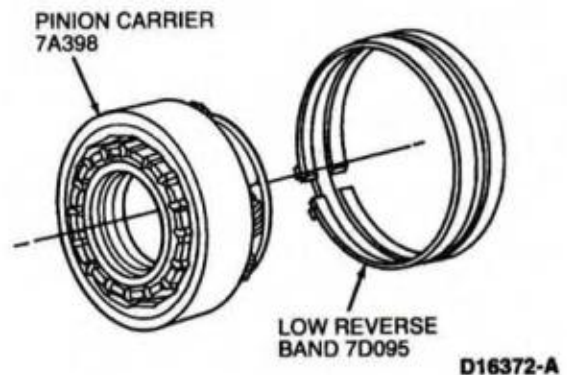

**DESCRIPTION AND OPERATION (Continued)**

**Clutch—Forward**

The forward clutch couples the input shaft to the forward sun gear in first, second and third gears.

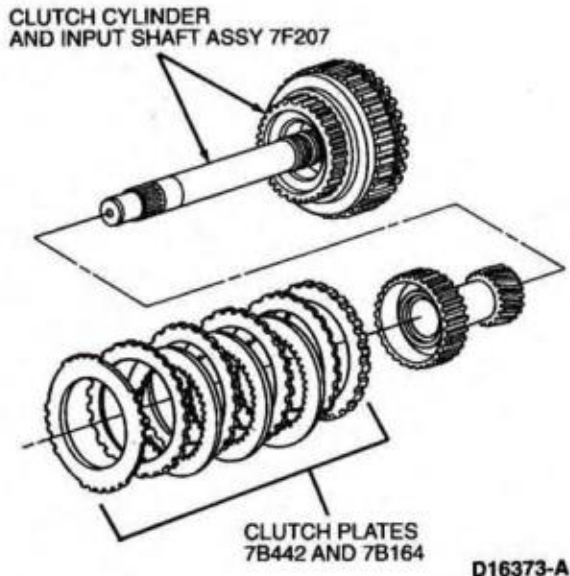

**Clutch—Direct**

The direct clutch couples the input shaft to the planet carrier (through the stub shaft) in third and fourth gears.

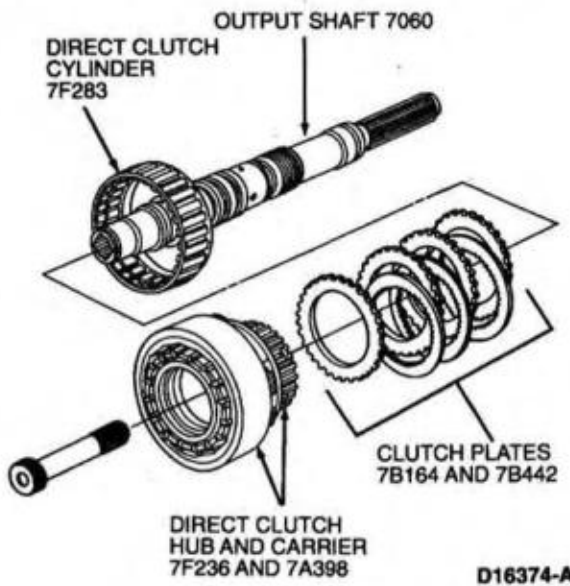

**Clutch—Reverse**

The reverse clutch couples the input shaft to the reverse sun gear. It is applied in reverse range only.

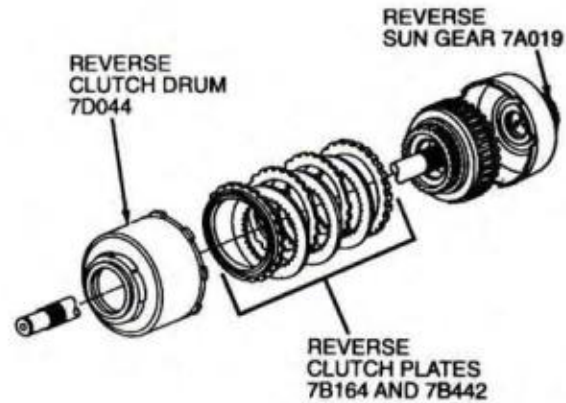

**Clutch—Intermediate**

The intermediate clutch works with the intermediate one-way clutch to hold the reverse sun gear stationary in second gear. The intermediate clutch remains applied in third and fourth gears, but does not transmit power.

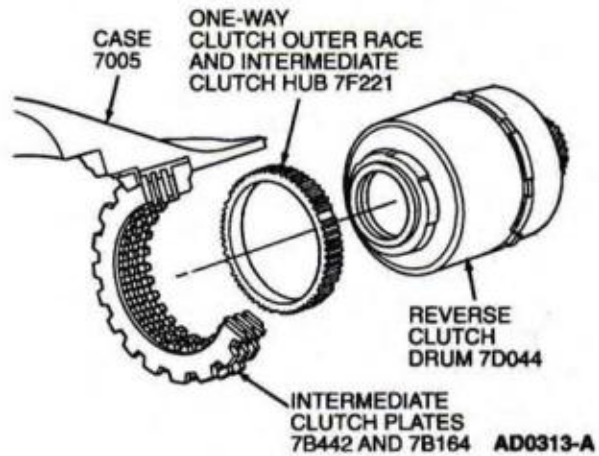

ProCarManuals.com

**DESCRIPTION AND OPERATION (Continued)**

**Clutch—Intermediate One-Way**

The intermediate one-way clutch is a roller clutch that works with the intermediate friction clutch to hold the reverse sun gear stationary in second gear during acceleration. This one-way clutch freewheels in third gear and during coasting in second gear,  $\text{Ⓔ}$  and D ranges.

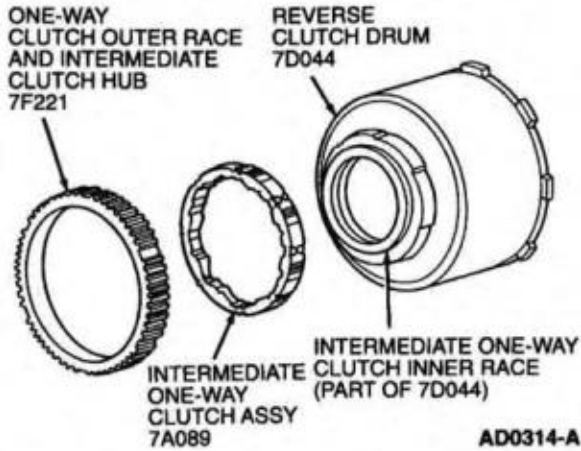

**Clutch—Planetary (Low) One-Way**

The planetary (low) one-way clutch is a roller clutch that holds the pinion carrier stationary in first gear,  $\text{Ⓔ}$  and D ranges), during automatic coasting downshifts into first gear ( $\text{Ⓔ}$  and D ranges), it freewheels so that there is no engine braking.

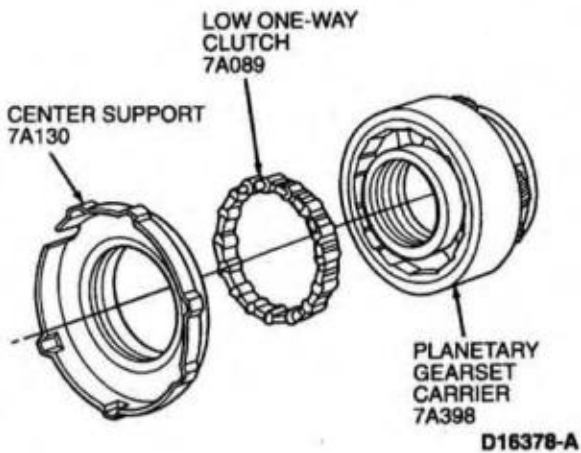

**Hydraulic System**

**Fluid Pump**

The transmission uses a gerotor design front pump support and gear (7A 103). The pump is more efficient at lower engine speeds. It is also made of aluminum.

The pump provides the volume of fluid needed to charge the torque converter, main control assembly, cooling system and lube system. Pump pressure is regulated by the main regulator valve. The pump also has an internal boost circuit.

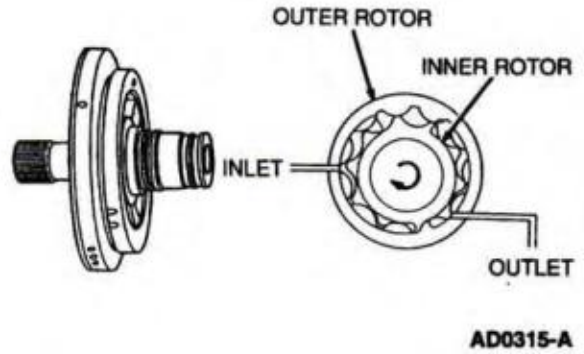

**Filter**

All fluid drawn from the pan by the pump passes through the filter. The filter and its accompanying seal are part of the fluid path from the sump (pan) to the fluid pump.

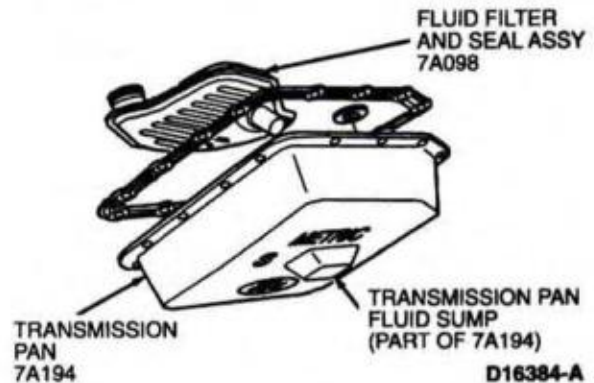

**DESCRIPTION AND OPERATION (Continued)****Main Control Valve Body**

The main control valve body houses three electronic solenoids:

- two shift solenoids (7G484).
- torque converter clutch solenoid (TCC solenoid)(7G136).

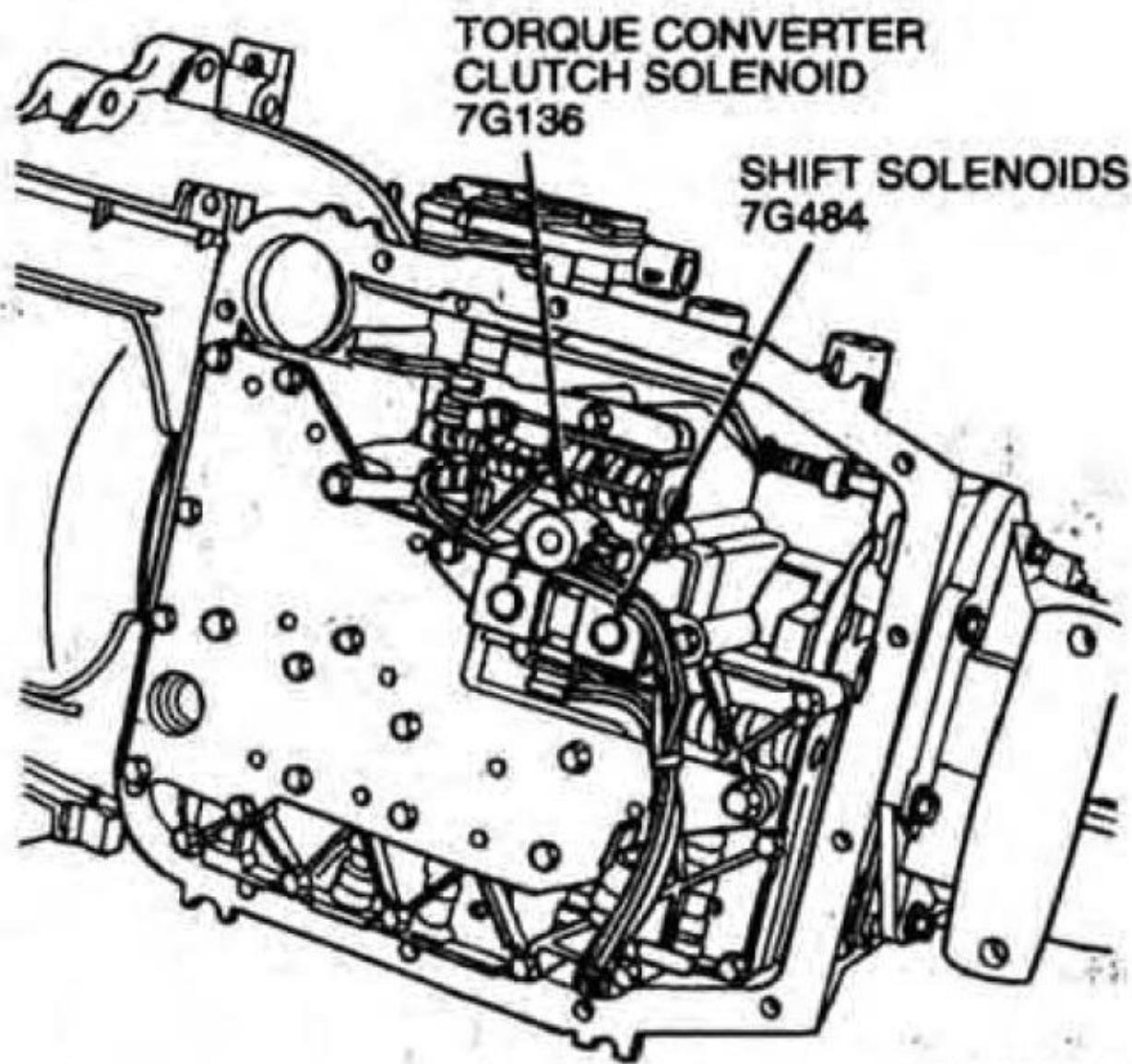

AD0316-A

**Accumulators****1-2 Accumulator**

The 1-2 accumulator (in the case) is used to soften the 1-2 shift by absorbing some of the pressure directed to the intermediate clutch. Constant line pressure is applied to the middle section of the 1-2 accumulator piston, opposing the intermediate clutch pressure until this pressure is enough to overcome line pressure. The top of the piston is exhausted to the sump.

**2-3 Accumulator**

The 2-3 accumulator is used to soften the 2-3 shift by absorbing some of the direct clutch pressure. Forward clutch pressure is applied to the top side of the accumulator piston, holding the piston down until direct clutch pressure is enough to overcome it. The middle section of the accumulator is exhausted to the sump. The 2-3 accumulator also helps control forward engagement.

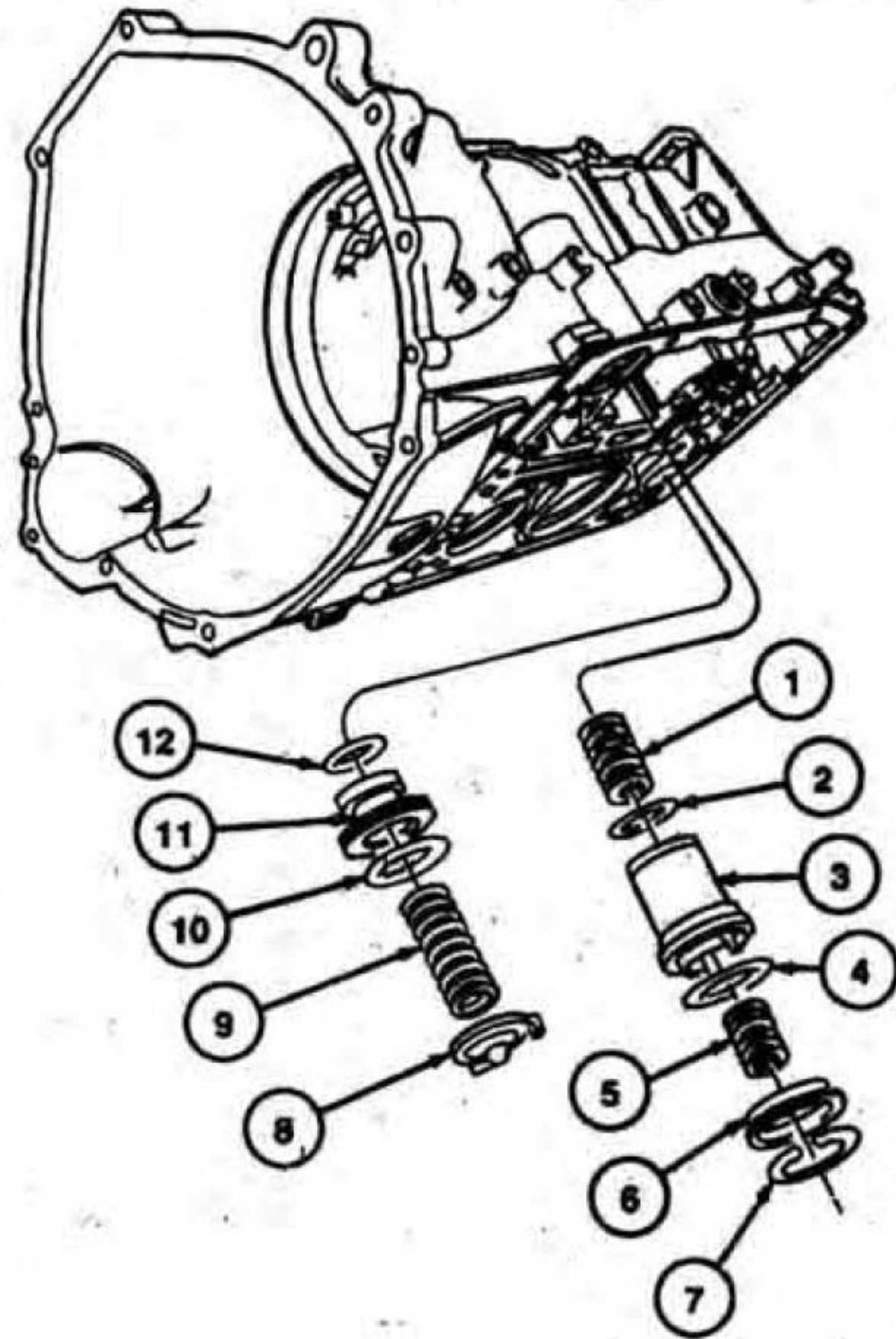

D16385-A

Item	Part Number	Description
1	7F284	Spring—1-2 Shift Accumulator (Model Dependent)
2	7F248	Seal—1-2 Shift Accumulator Piston
3	7F251	Piston—1-2 Shift Accumulator
4	7F249	Seal—1-2 Accumulator Piston - Lower
5	7F284	Spring—1-2 Shift Accumulator
6	7H300	Cover and Seal Assy—1-2 Accumulator
7	7384	Ring—2 1/16 Retaining Type HU Internal
8	7B264	Retainer—2-3 Shift Accumulator Piston
9	7F285	Spring—2-3 Shift Accumulator Piston
10	7F249	Seal—2-3 Accumulator Piston - Lower
11	7F251	Piston—2-3 Shift Accumulator
12	7F250	Seal—2-3 Accumulator Piston - Upper

**DESCRIPTION AND OPERATION (Continued)****Transmission Electronic Control System**

The powertrain control module (PCM)(12A650) and its input/output network control the following transmission operations:

- shift scheduling
- line pressure (shift feel)
- torque converter clutch

The transmission control is separate from the engine control strategy in the PCM, although some of the input signals are shared.

The PCM receives some input signals from engine-related sensors, including:

- mass air flow sensor (MAF sensor)(12B579).
- engine coolant temperature sensor (ECT sensor)(12A648).
- barometric pressure sensor (BARO sensor).

These signals provide information to the powertrain control module about the load and climate under which the engine is operating. Some other inputs are based on driver inputs, such as accelerator pedal position which is related to the powertrain control module by the throttle position sensor (TP sensor)(9B989). Still other inputs are provided by:

- transmission components.
- output shaft speed (OSS) sensor.
- transmission range (TR) sensor (controlled by driver placement of the shift lever).
- transmission fluid temperature sensor (TFT sensor).

Using all of these input signals, the powertrain control module can determine when the time and conditions are right for a shift or torque converter clutch application. The PCM can also determine the line pressure needed to optimize shift feel. To accomplish these functions, the PCM controls four electronic solenoids:

- two on/off shift solenoids (7G484)
- one pulse-width modulated torque converter clutch solenoid (TCC solenoid)(7G136) for torque converter clutch (TCC) control or "controlled slip" of the torque converter clutch

- an electronic pressure control (EPC) solenoid for line pressure control

The powertrain control module receives and sends electrical signals that are used to make the transmission more responsive to driver and vehicle needs.

The driver demands are transmitted to the powertrain control module through four components:

- **Transmission range selector lever**—The driver's demand for a particular gear range is translated into an electrical signal for the powertrain control module by the transmission range (TR) sensor.
- **Accelerator pedal**—The driver's demand for torque and acceleration are sent mechanically to the throttle body (9E926) on the engine. A throttle position sensor then translates this mechanical motion into an electrical signal and sends it to the powertrain control module.
- **Brake pedal**—A brake on/off (BOO) switch tells the powertrain control module when the brake is applied, indicating the driver demand to disengage the torque converter (7902).
- **Transmission Control Switch**—A momentary contact switch, located on the side of the transmission range selector that allows the driver to manually select three or four speed operation.

DESCRIPTION AND OPERATION (Continued)

Transmission Electronic Control System

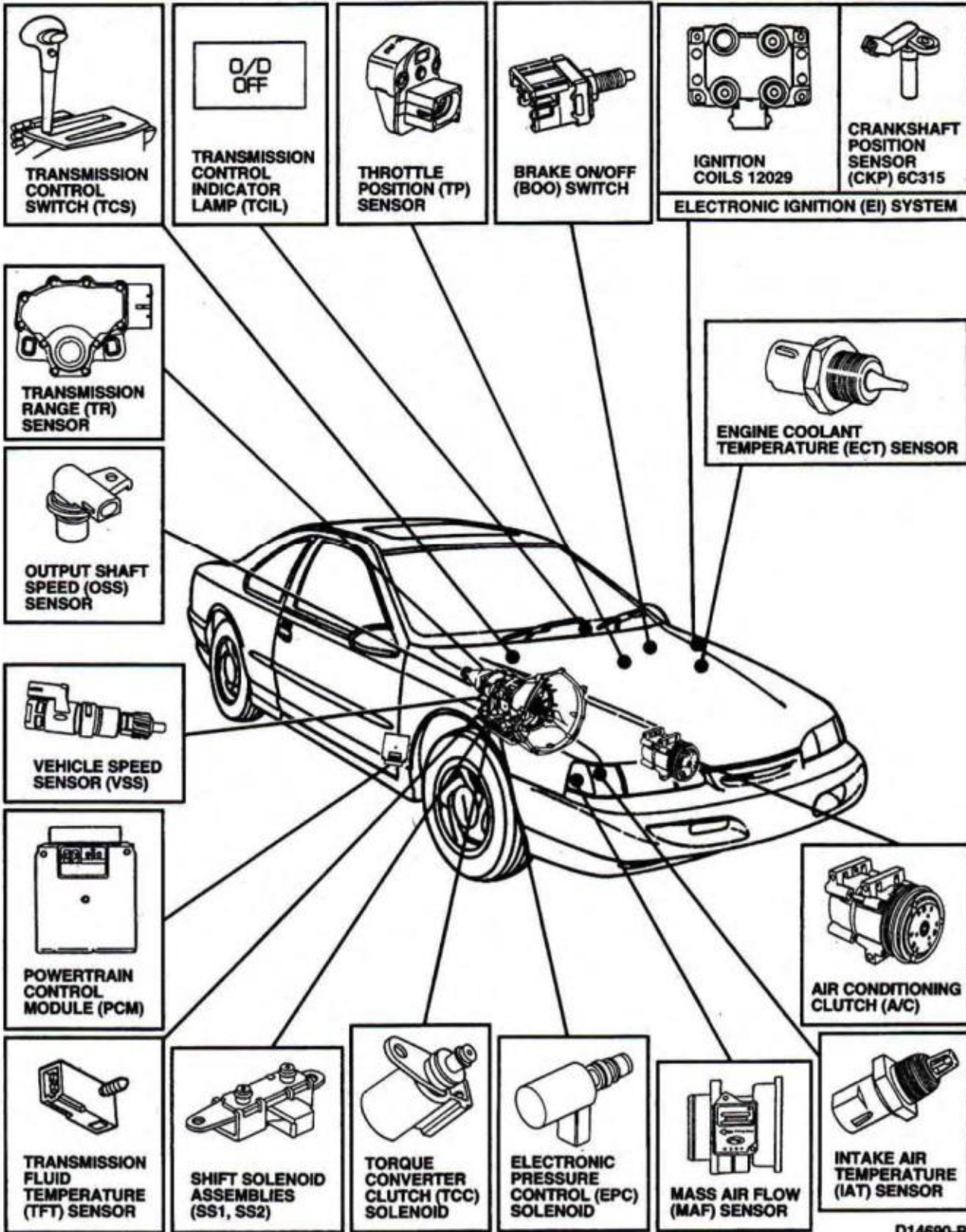

D14690-B

ProCarManuals.com

## DESCRIPTION AND OPERATION (Continued)

**Powertrain Control Module (PCM) 12A650:**

The operation of the transmission is controlled by the powertrain control module. Many input sensors provide information to the powertrain control module. The powertrain control module then controls actuators which determine transmission operation.

**DTCs:** P0605, P1605, P0603

**Engine Coolant Temperature (ECT) Sensor 12A648:**

The engine coolant temperature sensor detects temperature of engine coolant and supplies information to the powertrain control module. The engine coolant temperature sensor is installed into the heater outlet fitting or cooling passage on the engine. For engine control applications, the ECT signal is used to modify ignition control, EGR flow and air-to-fuel ratio as a function of engine coolant temperature. On electronic instrument clusters, the ECT output is used to control the coolant temperature indicator. The ECT sensor is used to control torque converter clutch operation.

**Symptoms:** Torque converter clutch will always be off, resulting in reduced fuel economy.

**DTCs:** P0117, P0118, P1116, P1117

**Intake Air Temperature (IAT) Sensor 12A697:**

The intake air temperature sensor provides the sequential fuel injection (SFI) system with mixture (fuel and air) temperature information. The intake air temperature sensor is used both as a density corrector for air flow calculation and to proportion cold enrichment fuel flow. The intake air temperature sensor is installed in the air cleaner outlet tube and provides the fuel system with mixture temperature information. The intake air temperature sensor is used in determining EPC pressure.

**Symptoms:** Incorrect EPC pressure, either high or low, will result in either harsh or soft shifts.

**DTCs:** P0112, P0113, P0114

**Transmission Control Switch (TCS) and Transmission Control Indicator Lamp (TCIL) 7G550:**

The transmission control switch is a momentary contact switch. When the switch is pressed, a signal is sent to the powertrain control module to allow automatic shifts from first through fourth gears or first through third gears only. The powertrain control module energizes the transmission control indicator lamp (TCIL) when the switch is off. The TCIL indicates overdrive cancel mode activated (lamp ON) and EPC circuit shorted (lamp flashing) or monitored sensor failure.

**Sensor:** Transmission Control Switch (TCS)

**Symptoms:** No overdrive cancel when switch is cycled.

(Continued)

**Transmission Control Switch (TCS) and Transmission Control Indicator Lamp (TCIL) 7G550: (Cont'd)**

**DTC:** P1780 tested during Key On Engine Off (KOEO) Self-Test.

**Actuator:** Transmission Control Indicator Lamp (TCIL)

**Symptoms:**

- **FAILED ON** —Overdrive cancel mode always indicated, no flashing for EPC circuit shorted or monitored sensor failure.
- **FAILED OFF** —Overdrive cancel mode never indicated, no flashing for EPC circuit shorted or monitored sensor failure.

**DTC:** N/A

**Transmission Fluid Temperature (TFT) Sensor 7H141:**

The transmission fluid temperature (TFT) sensor is located on the transmission main control valve body. It is a temperature sensitive device called a thermistor. The resistance value of the TFT will vary with temperature change. The powertrain control module monitors the voltage across the TFT to determine the temperature of the transmission fluid. The powertrain control module uses this voltage signal to determine whether a cold start shift schedule is necessary. The shift schedule is compensated when the transmission fluid is cold. The powertrain control module also inhibits torque converter clutch operation at low transmission fluid temperatures and corrects EPC pressures for temperature.

**Symptoms:** Torque converter clutch (TCC) engagement and stabilized shift schedules happen too soon after a cold start.

**DTCs:** P0712, P0713, P1711, P1783, P1710

**Transmission Range (TR) Sensor 7A247:**

The processor sends a voltage signal to the transmission range (TR) sensor. The TR sensor incorporates a series of step-down resistors which act as a voltage divider. The processor monitors this voltage which corresponds to the position of the manual control lever (P, R, N, , 2, 1). The TR sensor is located on the outside of the transmission at the manual control lever. The TR sensor determines desired gear and EPC pressure. The TR sensor also contains circuits for Park/Neutral and backup lamps.

**Symptoms:** Engagement concerns, wrong gear, no shifts, increase in EPC pressure.

**DTCs:** P0707, P0708, P1705, P0705

## DESCRIPTION AND OPERATION (Continued)

**Stoplight Switch 13480:**

The brake on / off (BOO) switch tells the powertrain control module when the brakes are applied. The switch closes when brakes are applied and opens when they are released. The BOO switch will also disengage torque converter clutch when the brake is applied.

**Symptoms:**

- Failed ON—torque converter clutch will not engage at less than one-third throttle.
- Failed OFF (or not connected)—torque converter clutch will not disengage when brake is applied.

**DTCs:** P1703

**Electronic Ignition (EI) System:**

The electronic ignition system consists of the powertrain control module, a crankshaft position sensor and two 4-tower ignition coils. The crankshaft position sensor sends a crankshaft position signal to the powertrain control module. The powertrain control module then sends the appropriate ignition signal to the ignition coils. The powertrain control module also uses this signal in the transaxle strategy as well as wide open throttle (WOT) shift control, torque converter clutch control and electronic pressure control.

**Symptoms:** Harsh engagement and shifts, late WOT shift and no torque converter clutch engagement.

**DTCs:** P0300-P0308, P0340, P1351 through P1364, P0320

**Air Conditioning Clutch (A/C Clutch) 2884:  
OEM Factory Installed**

An electromagnetic clutch is energized when the A/C cycling switch closes. The A/C cycling switch is located on the suction accumulator / drier. The closing of the switch contacts completes the circuit to the A/C clutch and draws it into engagement with the compressor driveshaft. The powertrain control module uses this signal to adjust EPC pressure when the air conditioning clutch is engaged to compensate for additional load on the engine.

**Symptoms:**

- Failed ON —EPC pressure slightly low with A/C OFF.
- Failed OFF —EPC pressure slightly high with A/C ON.

**DTC:** P1460

**Mass Air Flow (MAF) Sensor 12B579:**

The mass air flow sensor directly measures the mass of air flowing into the engine. The sensor output is a DC (analog) signal ranging from 0.5 volt to 5 volts used by the powertrain control module to calculate fuel injector pulse width. For transmission strategies this mass air flow sensor is used for EPC pressure control, shift and torque converter clutch scheduling. The powertrain control module uses this signal for EPC pressure control, shift and torque converter clutch scheduling.

**Symptoms:** High / low EPC pressure, incorrect shift schedule, incorrect converter engagement scheduling and symptoms similar to a throttle position (TP) sensor malfunction.

**DTCs:** P0102, P0103, P1100, P1101

**Throttle Position (TP) Sensor 9B989:**

The throttle position sensor is a potentiometer mounted on the throttle body. The TP sensor detects the position of the throttle plate and sends this information to the powertrain control module as a varying voltage signal. The powertrain control module uses this signal to control shift scheduling, EPC pressure control and torque converter clutch control.

**Symptoms:** Harsh engagements, firm shift feel, abnormal shift schedule, torque converter clutch does not engage, torque converter clutch cycling.

**DTCs:** P0122, P0123, P1120, P1124

**Output Shaft Speed Sensor (OSS) 7H103:**

The output shaft speed (OSS) sensor is a magnetic pickup, located at the output shaft ring gear that sends a signal to the powertrain control module to indicate transmission output shaft speed. The powertrain control module uses this signal for torque converter clutch control, shift scheduling, used in determining EPC pressure.

**Symptoms:** No converter engagements, harsh shifts, abnormal shift schedules.

**DTC:** P0720, P0721

**Vehicle Speed Sensor (VSS) 9E731:**

The vehicle speed sensor is a magnetic pickup that sends a signal to the powertrain control module. This VSS signal tells the PCM vehicle speed. The PCM uses this signal to modify upshift schedules.

**Symptoms:** Shift engagement / disengagement (hunting) on grades.

**DTC:** P0500, P0503, P1500, P1501, P0501

## DESCRIPTION AND OPERATION (Continued)

**Shift Solenoid Assembly, Shift Control Solenoids 1 and 2 (7G484):**

Two ON/OFF shift solenoids are used for electronic shift scheduling. One unit containing the two shift solenoids is located in the main control valve body. The shift solenoids are two-way, normally closed style. Shift solenoids (SS-1 and SS-2) provide gear selection of first through fourth gears by controlling the pressure to the three shift valves.

**SS-1 Symptoms:** Improper gear selection depending on failure mode and manual lever position.

- Failed ON—first and fourth gear only.
- Failed OFF—second and third gear only.

**DTCs:** P0750\*, P0751\*\*, P0781\*\*, P0782\*\*, P0783\*\*, P1751, P1714

**SS-2 Symptoms:** Improper gear selection depending on failure mode and manual lever position.

- Failed ON—third and fourth gear only.
- Failed OFF—first and second gear only.

**DTCs:** P0755\*, P0756\*\*, P0782\*\*, P0783\*\*, P1756, P1715

**SS-1 and SS-2 Symptoms:**

- Both failed ON—fourth gear only.
- Both failed OFF—second gear only.

**DTCs:** P0750\*, P0751, P0755\*, P0756

\* Output circuit check, generated only by electrical conditions.

\*\* May also be generated by some non-electrical transmission component condition.

**Torque Converter Clutch (TCC) Solenoid 7G136:**

The torque converter clutch solenoid is used to control the apply and release of the torque converter clutch.

**Symptoms:**

- Failed ON —engine stalls in second gear (D, 2 range) at low idle speeds with the brake applied.
- Failed OFF —torque converter clutch never engages.

**DTCs:** P0741\*\*, P0743\*, P1744\*\*, P1741\*\*, P1742, P1743, P1767, P1740

\* Output circuit check, generated only by electrical conditions.

\*\* May also be generated by some non-electrical transmission component condition.

**Electronic Pressure Control (EPC) Solenoid 7G383:**

The electronic pressure control (EPC) solenoid regulates transmission EPC pressure. EPC valve pressure is used to control line pressure and the 2-3 backout valve function.

**Symptoms:**

- Failed ON —Minimum EPC pressure (minimum capacity), limit engine torque (alternate firing).
- Failed OFF — Maximum EPC pressure, harsh engagements, harsh shifts.

(Continued)

**Electronic Pressure Control (EPC) Solenoid 7G383: (Cont'd)**

**DTCs:** P1746\*, P1747\*

\* Output circuit check, generated only by electrical conditions.

\*\* May also be generated by some non-electrical transmission component condition.

**REFERENCE: SOLENOID OPERATION CHART #701**

Transmission Range Selector Lever Position	PCM Commanded Gear	Solenoids		
		SS-1	SS-2	TCC
P/R/N	1	ON	OFF	HD
D	1	ON	OFF	HD
D	2	OFF	OFF	EC
D	3	OFF	ON	EC
D	4	ON	ON	EC
D w/OD OFF				
1	1	ON	OFF	HD
2	2	OFF	OFF	EC
3	3	OFF	ON	EC
Manual 2	2	OFF	OFF	EC
Manual 1	1	ON	OFF	HD
1 <sup>a</sup>	2	OFF	OFF	EC

a When a manual pull-in occurs above a calibrated speed the transmission will downshift from the higher gear until the vehicle speed drops below this calibrated speed.

EC = Electronically Controlled

HD = Hydraulically Disabled

**DIAGNOSIS AND TESTING****Diagnostic Strategy**

Troubleshooting an electronically controlled automatic transmission is simplified by using the proven method of diagnosis. One of the most important things to remember is that there is a definite procedure to follow. **DO NOT TAKE SHORT CUTS OR ASSUME THAT CRITICAL CHECKS OR ADJUSTMENTS HAVE ALREADY BEEN MADE.** Follow the procedures as written to avoid missing critical components or steps.

**DIAGNOSIS AND TESTING (Continued)**

To properly diagnose a concern, the technician should have the following publications available:

- Transmission Reference Manual
- Powertrain Control / Emissions Diagnosis Manual<sup>1</sup>
- Oasis Messages
- Technical Service Bulletins (TSBs)
- Electrical and Vacuum Troubleshooting Manual (EVTM)

These publications provide the information required when diagnosing transmission concerns.

Using the Diagnostic Flow Chart as a guide, follow the steps as indicated.

**Preliminary Inspection**

- Know and understand the customer's concern.
- Verify the concern by operating the vehicle.
- Check the fluid level and condition.
- Check for non-factory add-on items.
- Check shift linkages for proper adjustment.
- Check TSBs and Oasis messages for the concern.

**Diagnostics**

- Perform on-board diagnostic procedures (KOEO, KOER).
- Record all diagnostic trouble codes (DTCs).
- Repair all non-transmission codes FIRST.
- Repair all transmission codes SECOND.
- Erase all CONTINUOUS codes and attempt to repeat them.
- Repair all continuous codes.
- If ONLY PASS codes, proceed to Diagnosis by Symptom Charts for further information and diagnosis.

By following the diagnostic sequence the service technician will be able to diagnose and repair the concern the first time.

<sup>1</sup> Can be purchased as a separate item.

### DIAGNOSIS AND TESTING (Continued)

#### Diagnostic Flow Chart

Rectangles are Action Boxes

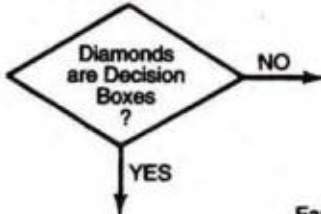

- Know and understand the customer's concern
- Check fluid level and condition
- Verify the concern by operating vehicle
- Check for non-factory installed items and verify proper installation
- Check shift linkage adjustment in overdrive
- Check TSB's and OASIS for vehicle concern
- Perform "Quick Test" both KOEO & KOER
- Record all codes

**NOTE:**  
If you find and repair the cause of the transmission concern at any point in this diagnostic flow chart, "go to" the last action box.

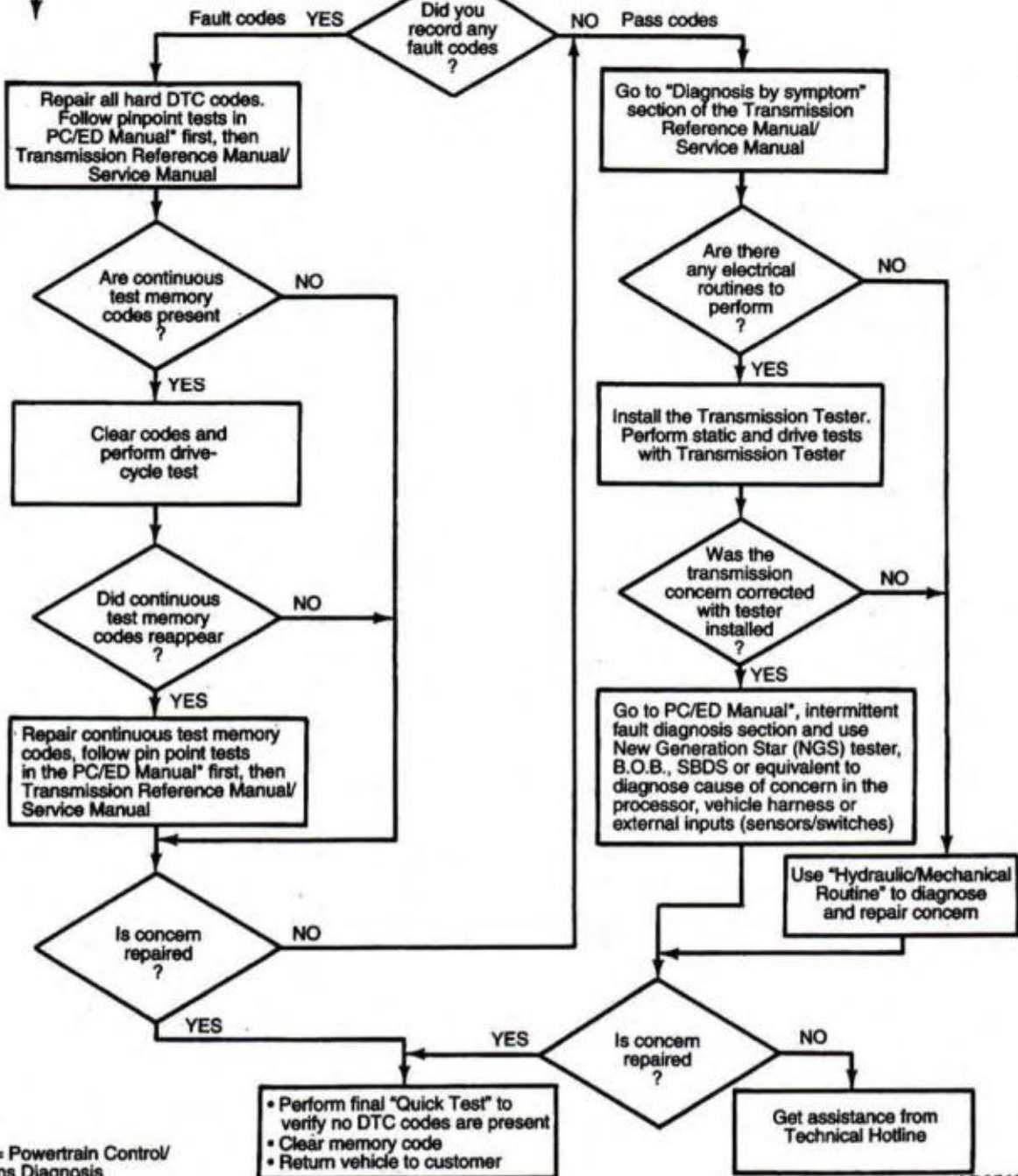

PC/ED = Powertrain Control/Emissions Diagnosis  
\*Purchased separately.

AD0518-A

## DIAGNOSIS AND TESTING (Continued)

### Preliminary Inspection

The following items must be checked prior to beginning the diagnostic procedures.

### Know/Understand The Concern

In order to properly diagnose a concern you must first understand the customer complaint or condition. Customer contact may be required in order for the technician to begin to verify the concern. You must understand the conditions as to when the concern occurs. For example:

- hot or cold vehicle temperature.
- hot or cold ambient temperature.
- vehicle driving conditions.

After understanding when and how the concern occurs then proceed to verifying the concern.

### Verification of Condition

This section provides information which must be used in both determining the actual cause of customer concerns and performing the appropriate service procedures.

NOTE: Some transmission conditions may cause engine concerns. An EPC short circuit may cause alternate firing. The torque converter clutch not disengaging will stall the engine.

The following procedures must be used when verifying customer concerns for transmission:

#### Required Equipment

- Rotunda Transmission Tester 007-00130 or equivalent
- 007-00128 MLP-C Cable
- 007-00122 AODE / 4R70W Cable and Overlay
- New Generation Star (NGS) Tester 007-00500 or equivalent
- Rotunda 73 Digital Multimeter 105-R0051 or equivalent
- Transmission Range (TR) Sensor (MLPS) Alignment Tool T93P-70010-A
- Rotunda 104 Pin Breakout Box 014-00950 or equivalent

#### Determine Customer Concern

- hot or cold vehicle operating temperature
- hot or cold ambient temperatures
- type of terrain
- vehicle loaded / unloaded
- city / highway driving

### Check Fluid Level and Condition

#### Fluid Level Check

**CAUTION:** To prevent transmission damage, do not drive vehicle if fluid level is below the bottom hole in fluid level indicator.

**CAUTION:** If vehicle has been operated for an extended period at high speed, in city traffic, in hot weather, or vehicle is being used to pull a trailer, the fluid has to cool approximately 30 minutes after engine has been turned off to obtain an accurate reading.

Under normal circumstances, you need to check the fluid level of the transmission during normal maintenance and change at 48,000 km (30,000 miles), since the vehicle does not use up transmission fluid. However, if the transmission is not working properly, for instance, the transmission may slip or shift slowly, or you may notice some sign of fluid leakage, the fluid level should be checked.

It is preferable to check the transmission fluid level at normal operating temperature after approximately 32 km (20 miles) of driving. However, if necessary, you can check the fluid level without having to drive the vehicle to obtain a normal operating temperature if outside temperature is above 10°C (50°F).

**CAUTION:** Your vehicle should not be driven if the fluid level is below the bottom hole on the fluid level indicator and outside temperature is above 10°C (50°F).

When checking fluid at normal operating temperature, the fluid level should be within the crosshatched area on the fluid level indicator. When the vehicle has not been driven, and outside temperature is above 10°C (50°F), the fluid level should be between the holes in the fluid level indicator.

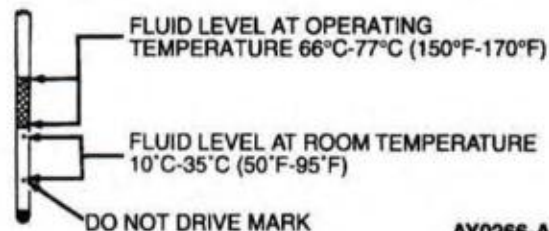

AY0266-A

NOTE: The fluid level indication on the fluid level indicator will be different at operating temperature and room temperature. For the correct fluid level reading on the fluid level indicator, follow the appropriate instructions stated previously.

Check fluid level as follows:

1. With transmission in PARK, engine at curb idle rpm, foot brakes applied and vehicle on level surface, move the transmission range selector lever through each range. Allow time in each range to engage transmission, return to PARK, apply parking brake control (2780) and block wheels. Do not turn off the engine during the fluid level check.

**DIAGNOSIS AND TESTING (Continued)**

2. Clean all dirt from the transmission fluid level indicator cap before removing the fluid level indicator from the fluid filler tube.
3. Pull the fluid level indicator out of the fluid filler tube, wipe it clean, and push all the way back into the tube. Make sure it is fully seated.

4. Pull the fluid level indicator out of the fluid filler tube again and check the fluid level.

If necessary, add enough fluid through the fluid filler tube to raise the level to the correct position. Do not overfill the transmission. This will result in foaming, loss of fluid through the vent and possible transmission malfunction. If overfill occurs, excess fluid must be removed.

5. Install the fluid level indicator, making sure it is fully seated in the fluid filler tube.

If the transmission fluid level is correctly established at 21°-35°C (70°-95°F), it will appear in the cross-hatch area on the fluid level indicator when the transmission reaches an operating temperature of 66°-77°C (150°-170°F). Do not overfill or underfill.

Underfill can result in transmission loss of engagement or slipping. This condition is most evident in cold weather or when the vehicle is parked or being driven on a hill.

If the transmission fluid level is checked when the fluid is at room temperature, the fluid level indicator could indicate that fluid should be added if the fluid level indicator is misread. If fluid is added at this time, an overfill condition could result when the fluid reaches operating temperatures of 66°-77°C (150°-170°F) (fluid level indicator hot to touch).

**High or Low Fluid Level**

A fluid level that is too high may cause the fluid to become aerated due to the churning action of the rotating parts of the transmission. Aerated fluid will cause erratic control pressure, and the aerated fluid may be forced from the vent.

A fluid level that is too low will affect transmission operation. Low level may indicate fluid leaks that may cause transmission damage.

**Adding Fluid**

**CAUTION: Use of any fluid other than specified could result in transmission malfunction or failure.**

If you need to add fluid, use Motorcraft MERCON® Multi-Purpose (ATF) Transmission Fluid XT-2-QDX or equivalent fluid meeting MERCON® specification. Before adding any fluid, be sure that the correct type will be used.

Add fluid in 0.25L (1/2 pint) increments through the filler tube to bring the level to the correct area on the dipstick. If an overfill occurs, excess fluid must be removed.

**Fluid Change—Drain/Refill**

Normal maintenance and lubrication requirements necessitate periodic automatic transmission fluid changes. If a major service, such as a clutch, band, bearing, etc., is required, the transmission will have to be removed for service.

At this time, the torque converter (7902), transmission fluid cooler and fluid cooler tubes must be thoroughly flushed to remove any dirt. When used under continuous or severe conditions, the transmission and torque converter should be drained and refilled with fluid as specified.

**CAUTION: Use of a fluid other than specified could result in transmission malfunction and/or failure.**

Refer to the Vehicle Certification Label affixed to the LH front door lock face panel or door pillar for the transmission code.

When filling a dry transmission or torque converter, refer to Specifications for capacity. Check the fluid level.

Procedures for partial drain and refill, due to in-vehicle service operations, are as follows:

1. Raise and suitably support vehicle on hoist or jackstands. Refer to Section 00-02.
2. Place drain pan under transmission.
3. Loosen transmission pan retaining bolts and drain fluid from transmission.
4. When fluid has drained to the level of the pan flange, remove the remaining pan bolts working from the RH side allowing the pan to lower and drain slowly.
5. Drain the torque converter by removing the torque converter drain plug.
6. After the torque converter has been drained, install a new torque converter drain plug and tighten to 28-30 N·m (21-22 lb·ft).
7. When all fluid has been drained from the transmission, remove and thoroughly clean the transmission pan.
8. Clean, inspect and install the pan-to-case gasket on the transmission pan and install transmission pan on transmission.
9. Lower vehicle.
10. When filling a dry transmission and converter, start with a minimum of 6.1 liters (6.5 quarts). Refer to Specifications for capacity.
11. Fill transmission to proper level using Motorcraft MERCON® Multi-Purpose (ATF) Transmission Fluid XT-2-QDX or equivalent fluid meeting MERCON® specification.

**Transmission Fluid Condition Check**

1. Make the normal fluid check as described.

## DIAGNOSIS AND TESTING (Continued)

2. Observe color and odor of the fluid. It should be dark reddish, not brown or black. Odor can sometimes indicate that there is an overheating condition or clutch disc or band failure.
3. Use a clean, lint-free cloth to wipe the fluid level indicator. Examine the stain on tissue for evidence of solids (specks of any kind) and for antifreeze signs (gum or varnish on fluid level indicator).

If specks are present in the fluid or there is evidence of antifreeze, the transmission pan must be removed for further inspection. If fluid contamination or transmission failure is confirmed by further evidence of coolant or excessive solids in the transmission pan, the transmission must be disassembled and completely cleaned and serviced. This includes cleaning the torque converter (7902) transmission cooling system. It would be a waste of time to perform any further checks before cleaning and servicing the transmission. During disassembly and assembly, all overhaul checks and adjustments of clearances and end play must be made. After the transmission has been serviced, all diagnosis tests and adjustments listed in the Diagnosis by Symptom chart must be completed to ensure the concern has been corrected.

**Road Testing Vehicle**

The Shift Point Road Test and Torque Converter Clutch Operation Test provide diagnostic information on transmission shift controls and torque converter operation.

**Shift Point Road Test**

This test verifies that the shift control system is operating properly.

1. Bring engine and transmission up to normal operating temperature.
2. Operate vehicle with transmission range selector lever in  $\text{D}$  position.
3. Apply minimum throttle and observe speeds at which upshift occurs and torque converter engages (refer to Shift Speed chart).

NOTE: Shift speed ranges are approximate for all applications. For specific applications (engine, axle ratio and application) refer to the Automatic Transmission Specification issue FPS-12180-97.

4R70W SHIFT SPEEDS

Throttle Position	Range	shift	(MPH)
Light Throttle	$\text{D}$	1-2	7-15
	$\text{D}$	2-3	18-30

(Continued)

4R70W SHIFT SPEEDS (Cont'd)

Throttle Position	Range	shift	(MPH)
Closed Throttle	$\text{D}$	3-4	28-44
	$\text{D}$	4-3	36-25
	$\text{D}$	3-2	19-11
	$\text{D}$	2-1	10-5
Wide Open	$\text{D}$	1-2	34-55
	$\text{D}$	2-3	62-100
	$\text{D}$	3-2	78-25
	$\text{D}$	2-1	40-10

4. With vehicle in OVERDRIVE (fourth gear), press transmission control switch. Transmission should downshift to third gear. Remove foot from accelerator pedal; engine braking should occur.
5. Press accelerator pedal to floor (WOT). Transmission should shift from third to second gear, or third to first depending on vehicle speed. Torque converter clutch should disengage and then reapply.
6. With vehicle in  $\text{D}$  position above 80 km/h (50 mph) and less than half throttle, move the transmission range selector lever from  $\text{D}$  position to manual 2 position and remove foot from accelerator pedal. Transmission should immediately downshift into second gear. With vehicle remaining in manual 2 position, move transmission selector into manual 1 position, and release accelerator pedal. Transmission should downshift into first gear at speeds BELOW 48-56 km/h (30-35 mph).
7. If transmission fails to upshift / downshift or torque converter clutch does not apply and release, refer to Diagnosis by Symptom Routines.

**Torque Converter Diagnosis**

Prior to torque converter replacement all diagnostic procedures must be followed. This is to prevent the unnecessary replacement of a good torque converter. Only after a complete diagnostic evaluation can the decision be made to replace the torque converter.

Begin with the normal diagnostic procedures as follows:

- Preliminary Inspection
- Know and Understand the Customers Concern

**DIAGNOSIS AND TESTING (Continued)**

- Verify the Concern
  - a. Perform the Torque Converter Clutch Operation Test, refer to procedure in this section.
  - b. Run On-Board Diagnostics, refer to procedure in this section.
  - c. Repair all non-transmission related DTCs first.
  - d. Repair all transmission DTCs. Rerun On-Board Diagnostic to verify repair.
  - e. Perform Line Pressure Test, refer to procedure in this section.
  - f. Perform Stall Speed Test; refer to procedure in this section.
  - g. Diagnosis by Symptom Routines; refer to procedure in this section.
  - h. Use the index to locate the appropriate routine that best describes the symptom(s). The routine will list all possible components that may cause or contribute to the symptom. Check each component listed, diagnose and service as required, before servicing the torque converter.

- Perform Diagnostic Procedures.

**Torque Converter Clutch Operation Test**

This test verifies that the torque converter clutch control system and the torque converter are operating properly.

1. Perform Quick Test as described. Check for DTCs P0741, P1741, P0743, P1742, P1743 and P1744. Refer to Pinpoint Test C for diagnosis.
2. Connect a tachometer to engine.
3. Bring engine to normal operation temperature by driving vehicle at highway speeds for approximately 15 minutes in  $\text{D}$  position.
4. After normal operating temperature is reached, maintain a constant vehicle speed of about 80 km/h (50 mph) and tap brake pedal with the left foot.
5. Engine rpm should increase when brake pedal is tapped, and decrease about five seconds after pedal is released. If this does not occur, refer to Torque Converter Operation Concerns in the Diagnosis by Symptom Routines.
6. If vehicle stalls in  $\text{D}$  or manual 2 at idle with vehicle at a stop, move transmission range selector lever to manual 1 position. If vehicle stalls, refer to Torque Converter Operation Concerns in the Diagnosis by Symptom Routines. Service as required. If vehicle does not stall in  $\text{D}$ , refer to Electrical Diagnosis for PCM and Vehicle Harness Diagnosis in Pinpoint Test C.

**Visual Inspection**

This inspection will identify modifications or additions to the vehicle operation system that may affect diagnosis.

- a. Vehicle modification
- b. Electronic add-on items:
  - air conditioning
  - generators (alternators)
  - engine turbos
  - cellular telephones
  - cruise controls
  - CB radios
  - linear boosters
  - backup alarm systems
  - computers
- c. Leaks (Refer to Leakage Inspection)
- d. Proper linkage adjustments (refer to Section 07-05)
- e. These items, if not installed properly, will affect powertrain control module or transmission function. Pay particular attention to add on wiring splices in the powertrain control module harness or transmission wiring harness, abnormal tire size, or axle ratio changes.

**Check TSBs and OASIS**

Refer to all technical service bulletins and OASIS messages which pertain to transmission concerns and follow the procedures as described.

**Perform On-Board Diagnostics**

After a road test, with the vehicle warm and before disturbing any connectors, perform the Quick Test using the Rotunda New Generation Star (NGS) Tester 007-00500 or equivalent. Refer to the Powertrain Control/Emissions Diagnosis Manual<sup>2</sup>.

<sup>2</sup> Can be purchased as a separate item.

## DIAGNOSIS AND TESTING (Continued)

### Diagnostics

Diagnosing an electronically controlled transmission is simplified by using the following procedures. One of the most important things to remember is that there is a definite procedure to follow. **DO NOT TAKE SHORT CUTS OR ASSUME THAT CRITICAL CHECKS OR ADJUSTMENTS HAVE BEEN MADE.** Follow the procedures as written to avoid missing critical components or steps. By following the diagnostic sequence, the service technician will be able to diagnose and repair the concern the first time.

### On-Board Diagnostics With NGS

The Quick Tests are in the Powertrain Control/Emissions Diagnosis Manual<sup>3</sup>. These tests can be used to diagnose the powertrain control module (PCM)(12A650), sensors and actuators of the 4R70W transmission.

The following is a guide for using the On-Board Diagnostic (OBD) Quick Tests and the Rotunda New Generation Star (NGS) Tester 007-00500 or equivalent, with some special considerations to remember:

**NOTE:** For detailed instructions and other diagnostic methods using the NGS, refer to the Powertrain Control/Emissions Diagnosis Manual<sup>3</sup> or NGS instruction guide.

**NOTE:** If using a generic scan tool, refer to the Powertrain Control/Emissions Diagnosis Manual<sup>3</sup> for instructions on performing OBD procedures.

#### Quick Test 1.0—Visual Inspection

Perform the Visual Check and Vehicle Preparation procedures as described in the Powertrain Control/Emissions Diagnosis Manual<sup>3</sup>.

Inspect the following:

- air cleaner and inlet ducting.
- all engine vacuum hoses for damage: leaks, cracks, blockage, proper routing, etc.
- PCM system wiring harnesses for proper connections, bent or broken pins, corrosion, loose wires, proper routing, etc.
- powertrain control module, sensors and actuators for physical damage.
- engine coolant for proper level.
- transmission fluid for proper level and condition.
- any NON-factory installed items wired into the transmission or PCM harnesses.

**NOTE:** Perform all necessary servicing before continuing with Quick Tests.

#### Quick Test 2.0—Set Up

Connect Rotunda New Generation Star (NGS) Tester 007-00500 or equivalent to data link connector (DLC).

The following are procedures to run OBD II procedures.

### Vehicle and Tester Preparation

Prepare the vehicle as follows:

- Place transmission range selector lever in PARK.
- Run engine to operating temperature.
- Apply parking brake.
- Block wheels.
- Turn off all electrical loads including A/C and defroster. (If A/C is ON, DTC P1460 will set.)

Prepare the NGS as follows:

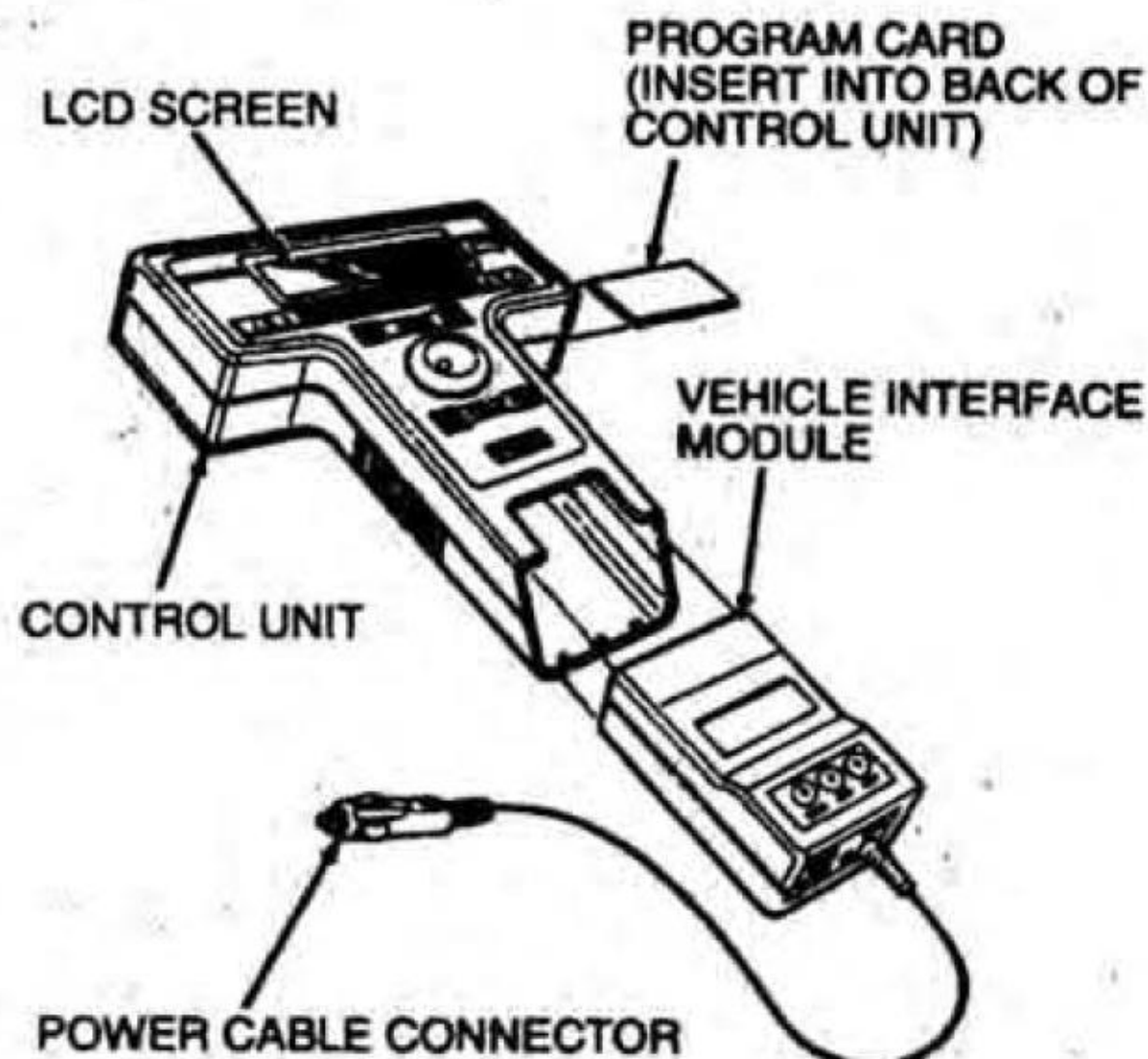

D12116-A

- Turn ignition switch to the OFF position.
- Verify that the proper PROGRAM card is inserted in the NGS.
- Connect J1962 / 16 way data communication link (DCL) cable adapter to the NGS.
- Connect NGS DCL cable adapter securely into the vehicle's data link connector.
- Connect the NGS power supply cable to the vehicle battery power supply through cigar lighter or at the battery with alligator clip adapter.
- Turn the Ignition switch to the RUN position, or start vehicle if necessary.
- The NGS is now ready to communicate with the PCM.

**NOTE:** Do not replace parts based on a code, perform Pinpoint Tests first.

#### Quick Test 3.0—Key On, Engine Off (KOEO)

Some special considerations for Key On, Engine Off Quick Test include the following:

- The KOEO test provides hard Diagnostic Trouble Codes (DTCs) present at the time of testing.
- Always service the hard DTCs first.

<sup>3</sup> Can be purchased as a separate item.

**DIAGNOSIS AND TESTING (Continued)****Performing KOEO**

- Perform visual inspection and vehicle preparation as required.
- Select "Vehicle and Engine Selection" menu.
- Select year, engine, model with the appropriate qualifier if needed, for example, transmission or 49 state / California.
- Select "Diagnostic Data Link" menu.
- Select "Output Test Mode" menu.
- Select "KOEO On-Demand Self-Test."
- Follow operating instructions from the NGS menu screen.
- Record all DTCs displayed.
- Service NON-transmission DTCs first as they can directly affect the operation of the transmission. Road test and repeat Quick Test to verify the service.

**Quick Test 4.0—Continuous Memory Codes**

Continuous DTCs are concerns which were detected during normal vehicle operation. These codes are retained for 40 warm-up cycles.

Some special considerations for continuous testing include the following:

- The cause of some continuous DTCs may have been eliminated if KOEO and / or KOER DTCs were serviced. Always re-test and service any DTCs that still remain.
- If DTCs are present, go to the On-Board Diagnostic Trouble Code Description Chart for service information. Erase DTC, perform the Transmission Drive Cycle and repeat all Quick Test procedures after completing service on the DTCs.
- If the continuous test passes (P1111) and a concern is still present, refer to the Diagnosis by Symptom routines, OASIS and TSBs for concern diagnosis.

**Performing Continuous Memory Codes**

- Select "Vehicle and Engine Selection" menu.
- Select year, engine and model with the appropriate qualifier if needed, for example, transmission or 49 state / California.
- Select "Diagnostic Data Link" menu.
- Select "Output Test Mode" menu.
- Select "Retrieve Continuous Codes" menu.
- Follow operating instructions from the NGS menu screen.
- Record all DTCs displayed.
- Perform Transmission Drive Cycle Test.
- Rerun Continuous DTC Test, if DTCs have returned, and service as required. Road test and rerun all DTC test procedures.

**Quick Test 5.0—Key On Engine Running (KOER)**

The Engine Running Quick-Test provides hard DTCs only.

Some special considerations for KOER Quick-Test include the following:

- Follow the menu screen instructions as they appear.
- If a DTC appears after the KOER test, a malfunction is present. Refer to the On-Board Diagnostic Trouble Code Description Chart for service information.

**Performing KOER Self-Test**

- Perform visual inspection and vehicle preparation as required.
- Select "Vehicle and Engine Selection" menu.
- Select year, engine and model with the appropriate qualifier if needed, for example, transmission or 49 state / California.
- Select "Diagnostic Data Link" menu.
- Select "Output Test Mode" menu.
- Select "KOER On-Demand Self-Test."
- Follow operating instructions from the NGS menu screen (example: turn key on, etc.) and perform Brake On / Off and cycle the transmission control switch (TCS) on and off, if equipped.
- Record all DTCs displayed.
- Service all NON-transmission DTCs first as they can directly affect the operation of the transmission. Road test and repeat Quick Test to verify service.

**Special Test Modes**

- Output test modes
- PCM Reset Mode (Clearing DTCs)

**Output Test Mode**

**CAUTION: Safety must be observed when using output test mode. When all outputs are on and the electric fuel pump is energized, make sure the fuel system is intact and is not being serviced at that time. When low speed or high speed cooling fans are turned on, make sure fan blades are clear of any obstruction.**

NOTE: As a safety precaution, the Output Test Mode will default to its normal state after ten minutes, after the vehicle is started or after cycling the ignition switch off and on.

The Output Test Mode (OTM) aids in servicing output actuators associated with the PCM system. It allows the technician to energize and de-energize most of the system output actuators on command. When entering OTM, the outputs can be turned off and on without controlling the cooling fans. The low and high speed cooling fans may be turned on separately without energizing the other outputs.

**DIAGNOSIS AND TESTING (Continued)****Accessing Output Test Mode:****New Generation Star**

Enter OTM with the ignition key on and the engine off.

- Perform the necessary vehicle preparation and visual inspection.
- Connect scan tool to DLC.
- Select "VEHICLE and ENGINE SELECTION" menu.
- Select NEW VEHICLE YEAR and MODEL.
- Enter year, engine, model with the appropriate qualifier if needed (i.e., transmission or 49 state / California).
- Select Diagnostic Data Link.
- Select PCM - POWERTRAIN CTRL MODULE.
- Select ACTIVE COMMAND MODES.
- Select OUTPUT TEST MODE.
- Turn key on.
- Follow operating instructions from the menu.
- Select the mode (i.e., ALL ON, ALL OFF, HIGH SPEED FAN or LOW SPEED FAN).
- Select START to turn outputs ON (may link up to PIDs).
- Select STOP to turn outputs OFF.

**PCM Reset Mode**

The PCM reset mode provides a means for the NGS to command the PCM to clear all DTCs. When resetting the PCM, a DTC P1000 will be set in the PCM until all OBD II system or components have been monitored during OBD II drive cycle.

A PCM reset:

- Clears the DTCs
- Clears the Freeze Frame Data
- Clears the Oxygen Sensor Test Data
- Resets the status of the OBD II System Monitors
- Sets the DTC P1000

**Performing PCM Reset**

- Perform visual inspection and vehicle preparation as required.
- Select "Vehicle and Engine Selection" menu.
- Select year, engine, model with the appropriate qualifier if needed, for example, transmission or 49 state / California.
- Select "Generic OBD II Functions" menu.
- Select "Clearing ALL Codes."
- Follow operating instructions from the NGS menu screen.
- Perform OBD II Drive Cycle—Clear DTC P1000.

**Clearing DTC #P1000**

In some localities it may become a legal requirement to pass an Inspection / Maintenance (I/M) test of the OBD II System. If the vehicle's OBD II system or its battery has just been serviced, the PCM system is reset to a "not ready for I/M testing" condition. To prepare the vehicle for this test and to clear the DTC P1000, the OBD II drive cycle must be performed.

**OBD II Drive Cycle**

The following Steps **MUST BE RUN IN THE ORDER SHOWN**. If Steps 2, 3 or 4 are interrupted, repeat the step before proceeding. Any safe driving mode is acceptable between steps.

Always drive vehicle in a safe manner according to traffic conditions and obey all traffic laws.

1. Start engine and drive vehicle in typical city stop and go traffic for at least 10 minutes after it has reached normal operating temperature.
2. Idle vehicle for at least 45 seconds, then accelerate at part throttle to near 72 km/h (45 mph).
3. Cruise and maintain a select speed in the range of 48 to 64 km/h (30 to 40 mph) on a level road with throttle held steady for at least one minute.
4. Cruise and maintain a select speed in the range of 64 to 105 km/h (40 to 65 mph) on a level road with throttle held steady for at least one minute and 20 seconds.
5. OBD II drive cycle has been completed.

**Other NGS Features**

For further information on other diagnostic testing features using the NGS or generic scan tool, refer to the Powertrain Control / Emissions Diagnosis Manual<sup>4</sup>.

Other diagnostic methods include the following:

- Parameter Identification (PID) Access Mode, used to monitor sensors and actuators.
- Freeze Frame Data Access Mode, used to view emission related data values from specific PIDs.
- Oxygen Sensor Monitor Mode, used to monitor the Heated Oxygen (HO<sub>2</sub>S) sensor.

**Transmission Drive Cycle Test**

After performing the Quick Test, use the following Transmission Drive Cycle Test for checking transmission continuous codes:

**NOTE:** The Transmission Drive Cycle Test must be followed exactly. A malfunction must occur four times consecutively for DTCs P0781, P1731, P0782, P1732, P0783, P1733 to be set, and five times consecutively for continuous DTC P0741.

1. Record and then erase Quick Test DTCs.
2. Warm engine to normal operating temperature.
3. Make sure transmission fluid level is correct.

<sup>4</sup> Can be purchased as a separate item.

**DIAGNOSIS AND TESTING (Continued)**

4. With transmission in OVERDRIVE, moderately accelerate from stop to 80 Km/h (50 mph). This allows the transmission to shift into fourth gear. Hold speed and throttle open steady for a minimum of 15 seconds.
5. With transmission in OVERDRIVE, press TCS (TCIL should illuminate) and moderately accelerate from stop to 64 Km/h (40 mph). This allows transmission to shift into third gear. Hold speed and throttle open steady for a minimum of 15 seconds (30 seconds above 1220 meters (4000 ft)).
6. Press TCS (TCIL should turn off) and accelerate from 64Km/h (40 mph) to 80 Km/h (50 mph). This allows transmission to shift into fourth gear. Hold speed and throttle position steady for a minimum of 15 seconds.
7. With transmission in fourth gear and maintaining steady speed and throttle opening, lightly apply and release brake (to operate stoplamps). Then hold speed and throttle steady for an additional five seconds minimum.
8. Brake to a stop and remain stopped for a minimum of 20 seconds.
9. Repeat Steps 4 through 8 at least five times.
10. Perform Quick Test and record continuous DTCs.

**After On-Board Diagnostics**

**NOTE:** The vehicle wiring harness, powertrain control module (PCM)(12A650) and non-transmission sensors may affect transmission operations. Service these concerns first.

**NOTE:** After electrical diagnosis has been performed and a concern still exists, refer to the Diagnosis by Symptom charts in this section.

Begin with non-transmission related DTCs, then service any transmission related DTCs. Refer to the On-Board Diagnostic Trouble Code Description Chart for information on condition and symptoms. This chart will be helpful in referring to the proper manual(s) and to aid in diagnosing internal transmission concerns and external non-transmission inputs. The pinpoint tests are used in diagnosing electrical concerns of the 4R70W transmission. Make sure that the vehicle wiring harness and the powertrain control module are diagnosed as well. The Powertrain Control/Emissions Diagnosis Manual<sup>5</sup> will aid in diagnosing non-transmission electronic components.

**Before Pinpoint Tests**

**NOTE:** Prior to entering pinpoint tests, check the PCM wiring harness for proper connections, bent or broken pins, corrosion, loose wires, proper routing, proper seals and their condition. Check the powertrain control module (PCM)(12A650), sensors and actuators for damage. Refer to the Powertrain Control/Emissions Diagnosis Manual.<sup>5</sup>

If DTCs appear, while performing the on-board diagnostics, refer to the On-Board Diagnostic Trouble Code Description Chart for the appropriate service procedure. Prior to entering the pinpoint tests, refer to any TSBs and OASIS messages for 4R70W transmission concerns.

<sup>5</sup> Can be purchased as a separate item.

## DIAGNOSIS AND TESTING (Continued)

**On-Board Diagnostic Trouble Code Description Chart**

Refer to the On-Board Diagnostic Trouble Code Description Chart for information on Condition and Symptoms. This chart will be helpful in referring to the proper manual(s) and to aid in diagnosing internal transmission concerns and external non-transmission inputs. The pinpoint tests are used in diagnosing electrical concerns of the transmission. Make sure that the vehicle wiring harness and the powertrain control module (PCM)(12A650) are diagnosed as well. The Powertrain Control/Emissions Diagnosis Manual<sup>6</sup> will aid in diagnosing non-transmission electronic components.

NOTE: The vehicle wiring harness, powertrain control module and non-transmission sensors may affect transmission operations. Service these concerns first.

**ON-BOARD DIAGNOSTIC TROUBLE CODE DESCRIPTION CHART**

\*\*May also be generated by some other non-electric transmission hardware system.

\*Output circuit check, generated only by electrical symptoms.

Four Digit DTC	Component	Description	Condition	Symptom	Action
P0112	IAT	IAT indicates 125°C (254°F) (grounded)	Voltage drop across IAT exceeds scale set for temperature 125°C (254°F).	Incorrect EPC pressure. Either high or low which will result in harsh or soft shifts.	Refer to PC/ED
P0113	IAT	IAT indicates -40°C (-40°F) (open circuit)	Voltage drop across IAT exceeds scale set for temperature -40°C (-40°F).	Incorrect EPC pressure. Either high or low which will result in harsh or soft shifts.	Refer to PC/ED
P0114	IAT	IAT out of on-board diagnostic range	IAT temperature higher or lower than expected during KOEO and KOER.	Rerun on-board diagnostic at normal operating temperature.	Refer to PC/ED
P1116	ECT	ECT out of on-board diagnostic range	ECT temperature higher or lower than expected during KOEO and KOER.	Rerun on-board diagnostic at normal operating temperature.	Refer to PC/ED
P0117	ECT	ECT indicates 125°C (254°F)	Voltage drop across ECT exceeds scale set for temperature 125°C (254°F) (grounded).	Torque converter clutch will always be off, resulting in reduced fuel economy.	Refer to PC/ED
P0118	ECT	ECT indicates -40°C (-40°F)	Voltage drop across ECT exceeds scale set for temperature -40°C (-40°F) (open circuit).	Torque converter clutch will always be off, resulting in reduced fuel economy.	Refer to PC/ED
P1124	TP	TP voltage high/low for on-board diagnostic.	TP was not in the correct position for on-board diagnostic.	Rerun at appropriate throttle position per application.	Refer to PC/ED
P0122, P0123, P1120	TP	TP concern	PCM has detected an error. This error may cause a transmission concern.	Harsh engagements, firm shift feel, abnormal shift schedule, torque converter clutch does not engage. Torque converter clutch cycling.	Refer to PC/ED
P0102, P0103, P1100, P1101	MAF	MAF concerns	MAF system has a malfunction which may cause a transmission concern.	High/low EPC pressure, incorrect shift schedule. Incorrect torque converter clutch engagement scheduling. Symptoms similar to a TP failure.	Refer to PC/ED
P0300-P0308, P0320, P0340, P1351-P1364	EI	EI System	EI system has a malfunction which may cause a transmission concern.	Harsh engagements and shifts, late WOT shifts, no torque converter clutch engagement.	Refer to PC/ED
P0500, P0503, P1500, P1501, P0501	VSS	Insufficient VSS input.	PCM detected a loss of vehicle speed signal during operation.	Torque converter clutch engages, shift engagement/disengagement (hunting) on grades.	Refer to PC/ED

(Continued)

## DIAGNOSIS AND TESTING (Continued)

## ON-BOARD DIAGNOSTIC TROUBLE CODE DESCRIPTION CHART (Cont'd)

\*\*May also be generated by some other non-electric transmission hardware system.

\*Output circuit check, generated only by electrical symptoms.

Four Digit DTC	Component	Description	Condition	Symptom	Action
P1703	BOO	Brake not actuated during on-board diagnostic.	Brake not cycled during KOER.	Failed ON or not connected—torque converter clutch will not engage at less than 1/3 throttle. Failed OFF or not connected—torque converter clutch will not disengage when brake is applied.	Refer to PC/ED
P1703	BOO	BOO switch circuit failed.	Brake ON/OFF circuit failure.	Failed ON or not connected—torque converter clutch will not engage at less than 1/3 throttle. Failed OFF or not connected—torque converter clutch will not disengage when brake is applied.	Refer to PC/ED
P1460	A/C	A/C clutch cycling pressure switch error	A/C or Defrost ON condition may result from A/C clutch being ON during on-board diagnostic.	DTC set during on-board diagnostic—rerun with A/C OFF. Failed ON—EPC pressure slightly low with A/C OFF.	Refer to PC/ED
P1117	ECT	Intermittent ECT signal to PCM	PCM has detected an intermittent signal.	Incorrect EPC pressure. Either high or low will result in harsh or soft shifts.	Refer to PC/ED
P0781**	SS1 or internal parts	1-2 shift error	Engine rpm drop not detected when 1-2 shift was commanded by PCM.	Improper gear selection depending on failure or mode and manual lever position. Shift errors may also be due to other internal transmission concerns (stuck valves, damaged friction material).	Refer to Solenoid On/Off Charts. Refer to Pinpoint Test A.
P0782**	SS1, SS2 or internal parts	2-3 shift error	Engine rpm drop not detected when 2-3 shift was commanded by PCM.	Improper gear selection depending on failure or mode and manual lever position. Shift errors may also be due to other internal transmission concerns (stuck valves, damaged friction material).	Refer to Solenoid On/Off Charts. Refer to Pinpoint Test A.
P0783**	SS1, SS2 or internal parts	3-4 shift error	Engine rpm drop not detected when 3-4 shift was commanded by PCM.	Improper gear selection depending on failure or mode and manual lever position. Shift errors may also be due to other internal transmission concerns (stuck valves, damaged friction material).	Refer to Solenoid On/Off Charts. Refer to Pinpoint Test A.
P0750*	SS1	SS1 solenoid circuit failure	SS1 circuit failed to provide voltage drop across solenoid. Circuit open or shorted or PCM driver failure during on-board diagnostic.	Improper gear selection depending on condition mode and manual lever position. See Solenoid On/Off chart.	Refer to Pinpoint Test A.
P0755*	SS2	SS2 solenoid circuit failure	SS2 circuit fails to provide voltage drop across solenoid. Circuit open or shorted or PCM driver failure during on-board diagnostic.	Improper gear selection depending on condition mode and manual lever position. See Solenoid On/Off chart.	Refer to Pinpoint Test A.

(Continued)

## DIAGNOSIS AND TESTING (Continued)

## ON-BOARD DIAGNOSTIC TROUBLE CODE DESCRIPTION CHART (Cont'd)

\*\*May also be generated by some other non-electric transmission hardware system.

\*Output circuit check, generated only by electrical symptoms.

Four Digit DTC	Component	Description	Condition	Symptom	Action
—	TCIL	TCIL circuit failure	TCIL circuit open or shorted.	Failed ON—Overdrive cancel mode on. NO flashing TCIL for EPC failure or sensor. Failed OFF—Overdrive cancel mode never indicated. NO flashing TCIL for EPC sensor failure.	Refer to PC/ED
P1747*	EPC	EPC solenoid circuit failure, shorted circuit or output driver.	Voltage through EPC solenoid is checked. An error will be noted if tolerance is exceeded.	Short Circuit—Causes minimum EPC pressure (minimum capacity) and limits engine torque (alternate firm).	Refer to Pinpoint Test E.
P1746*	EPC	Shorted PCM output driver.	Voltage through EPC solenoid is checked. An error will be noted if tolerance is exceeded.	Open Circuit—Causes maximum EPC pressure, harsh engagements and shifts.	Refer to Pinpoint Test E.
P0741**	TCC	TCC slippage detected.	The PCM picked up an excessive amount of slippage during normal vehicle operation.	Transmission slippage/erratic or no torque converter clutch operation. Flash TCIL.	Refer to Diagnosis by Symptom.
P1780	TCS	TCS not changing states.	TCS not cycled during self-test. TCS circuit open or shorted.	Rerun on-board diagnostic and cycle switch. No OD cancel when switch is cycled.	Refer to PC/ED
P1711	TFT	TFT out of on-board diagnostic range.	Transmission not at operating temperature during on-board diagnostic.	Warm vehicle to normal operating temperature.	Refer to Pinpoint Test B.
P0713	TFT	-40°C (-40°F) indicated TFT sensor circuit open.	Voltage drop across TFT sensor exceeds scale set for temperature -40°C (-40°F)	Firm shift feel.	Refer to Pinpoint Test B.
P0712	TFT	157°C (315°F) indicated TFT sensor circuit grounded.	Voltage drop across TFT sensor exceeds scale set for temperature of 157°C (315°F)	Firm shift feel.	Refer to Pinpoint Test B.
P0720	OSS	Insufficient input from output shaft speed sensor.	PCM detected a loss of OSS signal during operation.	Harsh shifts, abnormal shift schedule, no torque converter clutch activation.	Refer to Pinpoint Test F.
P0743*	TCC	TCC solenoid circuit failure during on-board-diagnostic.	TCC solenoid circuit fails to provide voltage drop across solenoid. Circuit open or shorted or PCM drive failure during on-board diagnostic.	Short circuit—Engine stalls in second (OD, 2range) at low idle speeds with brake applied. Open circuit—Torque converter clutch never engages.	Refer to Pinpoint Test C.
P1705	TR Sensor	TR sensor not indicating PARK during KOEO.	On-board diagnostic not run in PARK.	Rerun on-board diagnostic in PARK	Refer to Pinpoint Test D.
P1741**	TCC	Excessive torque converter clutch engagement error.	Excessive variations in slip (engine speed surge) across the torque converter clutch.	Engine RPM oscillation is present in 3rd gear.	Refer to Pinpoint Test C.
P1783	TFT	Transmission overtemp condition indicated.	Transmission fluid temperature exceeded 127°C (70°F).	Increase in EPC pressure.	Refer to Pinpoint Test B.
P0707, P0705	TR Sensor	TR sensor circuit below minimum voltage.	TR sensor, circuit or PCM shorted or grounded.	Increase in EPC pressure.	Refer to Pinpoint Test D.
P0708	TR Sensor	TR sensor circuit above maximum voltage.	TR sensor, circuit or PCM indicates open.	Increase in EPC pressure.	Refer to Pinpoint Test D.

(Continued)

## DIAGNOSIS AND TESTING (Continued)

ON-BOARD DIAGNOSTIC TROUBLE CODE DESCRIPTION CHART (Cont'd)					
**May also be generated by some other non-electric transmission hardware system.					
*Output circuit check, generated only by electrical symptoms.					
Four Digit DTC	Component	Description	Condition	Symptom	Action
P0751	SS1	Shift solenoid No. 1 functional failure.	Mechanical or hydraulic failure of the shift solenoid.	Improper gear selection depending on failure mode and manual lever position.	Refer to Solenoid On / Off Chart. Refer to Pinpoint Test A.
P0756	SS2	Shift solenoid No. 2 functional failure.	Mechanical or hydraulic failure of the shift solenoid.	Improper gear selection depending on failure mode and manual lever position.	Refer to Solenoid On / Off Chart. Refer to Pinpoint Test D.
P1742	TCC	TCC solenoid failed ON (California only).	TCC solenoid has failed ON by electric, mechanical or hydraulic concern.	Harsh shifts.	Refer to Pinpoint Test C.
P1743	TCC	TCC solenoid failed ON.	TCC solenoid has failed ON by electric, mechanical or hydraulic concern.	Harsh shifts.	Refer to Pinpoint Test C.
P1744	Transmission (California only)	Transmission slippage detected.	The PCM picked up an excessive amount of slippage during normal vehicle operation.	Transmission slippage / erratic or no torque converter clutch operation.	Refer to Diagnosis by Symptom.
P1751**	SS1	Shift solenoid No. 1 functional failure (California only)	Mechanical or hydraulic failure of the shift solenoid.	Improper gear selection depending on failure mode and manual lever position.	Refer to Solenoid On / Off Chart. Refer to Pinpoint Test A.
P1756**	SS2	Shift solenoid No. 2 functional failure (California only)	Mechanical or hydraulic failure of the shift solenoid.	Improper gear selection depending on failure mode and manual lever position.	Refer to Solenoid On / Off Chart. Refer to Pinpoint Test A.
P1714	SS1	SS1 malfunction.	Mechanical failure of the solenoid detected.	Improper gear selection depending on condition, mode and manual lever position. See Solenoid Operation Chart.	Refer to Pinpoint Test H
P1715	SS2	SS2 malfunction.	Mechanical failure of the solenoid detected.	Improper gear selection depending on condition, mode and manual lever position. See Solenoid Operation Chart.	Refer to Pinpoint Test H
P1728	Transmission	Transmission slippage detected.	The PCM has detected an excessive amount of slippage during normal operation.	Transmission slippage / erratic or no torque clutch operation.	Diagnosis by Symptom Charts.
P1767	TCC	TCC solenoid circuit failure during OBD test.	TCC solenoid circuit fails to provide voltage drop across solenoid. Circuit open or shorted or PCM driver failure during OBD Test.	Short Circuit: engine stalls in second (O/D, 2 range) at low idle speeds with brake applied. Open Circuit: Torque Converter never engages.	Refer to Pinpoint Test C
P1740	TCC	TCC malfunction.	Mechanical failure of the solenoid detected.	Failed ON - Engine stalls in 2nd (O/D 2 Ranges) at low idle speeds with brake applied. Failed OFF - Torque Converter never applies.	Refer to Pinpoint Test H

(Continued)

## DIAGNOSIS AND TESTING (Continued)

## ON-BOARD DIAGNOSTIC TROUBLE CODE DESCRIPTION CHART (Cont'd)

\*\*May also be generated by some other non-electric transmission hardware system.

\*Output circuit check, generated only by electrical symptoms.

Four Digit DTC	Component	Description	Condition	Symptom	Action
P0721	OSS	Output Shaft Speed Sensor signal noisy	PCM has detected an erratic OSS signal.	Harsh shifts, abnormal shift schedule, no torque converter clutch engagement.	Refer to Pinpoint Test F.
P1710	TFT	TFT in range failure.	PCM detected no change in TFT during operation.	Firm shifts, increase in EPC, TCIL flashing.	Refer to Pinpoint Test B.

PC/ED—Powertrain Control/Emissions Diagnosis Manual <sup>7</sup>.**Rotunda Transmission Tester**

Use Rotunda Transmission Tester 007-00130 and Rotunda AODE/4R70W cable/overlay 007-00122 or equivalent to diagnose electronically controlled transmissions. The following instructions outlined the set-up and use of this tester in the pinpoint tests for the 4R70W.

<sup>7</sup> Can be purchased as a separate item.

## DIAGNOSIS AND TESTING (Continued)

## AODE Overlay

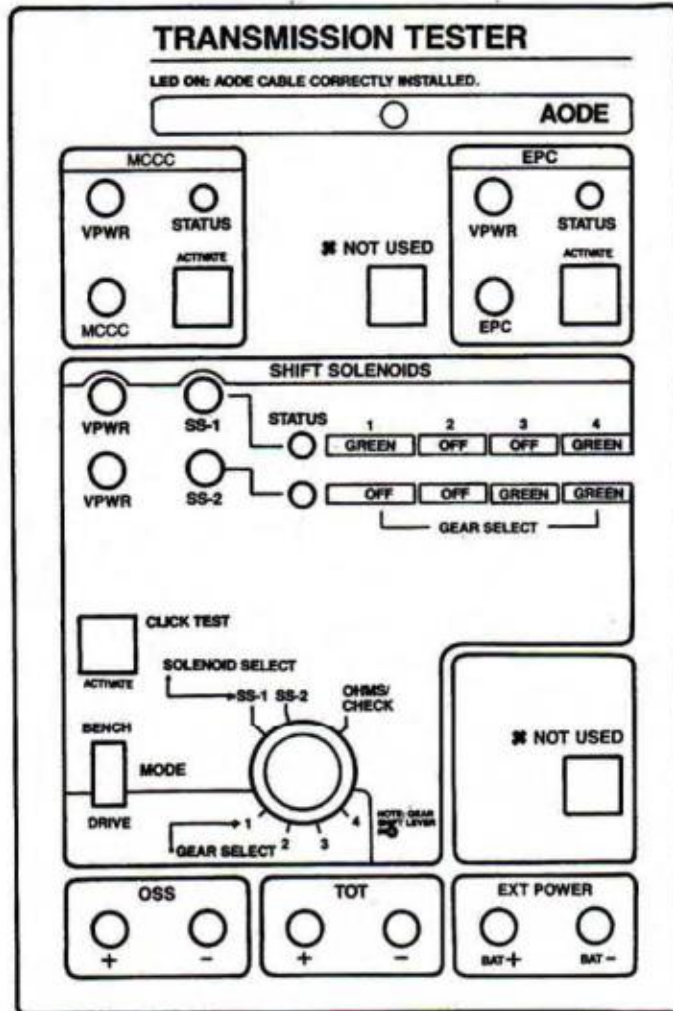

D10502-A

**Overlays and Adapters**

The following transmission tester overlays and adapters must be used with the Rotunda Transmission Tester 007-00130 or equivalent to properly diagnose the 4R70W transmission.

- 007-00128 MLP-C Cable
- 007-00122 AODE / 4R70W Cable and Overlay

**Tester Jacks**

1. **VPWR Pin Jacks (red):** VPWR test points for solenoid circuits.
2. **Solenoid (MCCC, EPC) Signal Line Pin Jacks (black):** Signal line test points for solenoid circuits.

**NOTE:** The tester overlay is labeled for the MCCC solenoid. This is used to test the torque converter clutch (TCC) solenoid.

3. **BAT+ (red) and BAT- (black) Pin Jacks:** Battery reference points when measuring circuits for shorts.
4. **TOT Pin Jacks:** Test points for transmission fluid temperature sensor (TFT sensor).
5. **OSS Pin Jacks:** Test points for output speed shaft sensor (OSS).

**LEDs and Controls**

1. **Cable Correctly Installed LEDs:** When LED is lit, the cable is installed correctly.

## DIAGNOSIS AND TESTING (Continued)

2. **Status LEDs:** LED OFF when not activated by tester (solenoid not activated, open circuit or signal line short to ground). LED green when activated by tester and current draw is correct. LED red when activated by tester and current draw is excessive (short to battery positive voltage (B+)). All LEDs light orange during self-test.
3. **Solenoid Activate Buttons:** Energize respective solenoids during click testing and activate selected circuits during DRIVE mode testing.
4. **Bench/Drive Switch:** Selects operating mode, either BENCH or DRIVE.
5. **Solenoid Select/Gear Select Switch:** Has three functions. In BENCH MODE: acts as shift solenoid selector for click testing. In DRIVE MODE: acts as forward gear selector in place of vehicle's PCM-controlled shifting. Hydraulic safety mechanisms and overrides are built in to the transmission. In OHMS CHECK: allows you to measure resistance (ohms).

### Instructions

The Rotunda Transmission Tester 007-00130 or equivalent allows a technician to operate the electrical portion of the transmission independent of the vehicle electronics. This allows the technician to determine transmission concerns.

The transmission tester usage is divided in five steps:

- (1) Preliminary testing and diagnosis
- (2) Installing the transmission tester
- (3) Static testing - engine OFF
- (4) Dynamic testing - engine running
- (5) Removing transmission tester and clearing diagnostic trouble codes

### Preliminary Inspections

Before any diagnostic testing is done on vehicle some preliminary checks must be performed, as described below. Be sure to write down findings, especially any DTCs found, for future reference.

- a. Check transmission fluid level and condition.
- b. Check for add-on items (phones, computers, CB radio, etc.).
- c. Visually inspect wiring harness and connectors.
- d. Check for vehicle modifications.
- e. Check shift linkage for proper adjustment.
- f. Verify customer concern:
  - upshift, downshift, coasting, engagement, noise/vibration
- g. Vehicle must be at normal operating temperature.
- h. Perform vehicle on-board diagnostic.
- i. Record all DTCs.
- j. Service all non-transmission codes.

### Installation Procedures

Installing the transmission tester at the transmission connector allows separation of the vehicle electronics from transmission electronics. Disconnecting normal vehicle electronics will set additional DTCs and cause firm shifts. (Disconnecting the transmission connector defaults transmission to maximum line pressure).

NOTE: During tester usage additional DTCs may be set. Therefore, it is important that all DTCs are erased after service has been made. To verify elimination of all DTCs rerun On-Board Diagnostic.

NOTE: The following manuals should be available to assist in diagnosis of electronically controlled transmissions:

- Powertrain Control/Emissions Diagnosis Manual.<sup>8</sup>
- Transmission Tester Manual (provided with tester).
- Electrical and Vacuum Troubleshooting Manual (EVTM).

1. **CAUTION: Do not attempt to pry off connectors with a screwdriver. This will damage the connector and could result in transmission concerns.**

Disconnect vehicle wiring harness at transmission connector.

2. Turn tester SOLENOID SELECT switch to the OHMS CHECK position.

3. **CAUTION: Route all cables away from heat source to prevent damage to cables.**

Connect appropriate tester interface cable and overlay to transmission and tester.

4. **CAUTION: Route gauge line away from heat sources to prevent damage to line.**

Install a line pressure gauge into line pressure tap on transmission.

5. Plug transmission tester power supply into cigar lighter receptacle. At this time, all LEDs should illuminate for a short period and then turn off. This is the tester internal circuit check.

6. Position BENCH/DRIVE switch to BENCH mode.

### Static Testing—Engine Off

Static testing procedures allow for shop testing of the transmission in the vehicle or on the bench. Completion of these tests prove out transmission electronics.

**CAUTION: For resistance checks, be sure the tester Solenoid Select switch is set to the OHMS CHECK position or damage to the ohmmeter may result.**

### Resistance/Continuity Tests—EPC Solenoid

- Set ohmmeter to 100-200 ohm range.
- Connect negative lead of ohmmeter to the EPC jack.

<sup>8</sup> Can be purchased as a separate item.

## DIAGNOSIS AND TESTING (Continued)

- Connect positive lead of ohmmeter to the VPWR jack.
  - Record resistance.
  - Refer to the following charts for values.
- If out of specification, refer to Pinpoint Test E.

### Resistance/Continuity Tests—Solenoids (SS-1, SS-2, TCC)

- Set ohmmeter to 100-200 ohm range.
- Connect positive lead of ohmmeter to the appropriate VPWR jack for the solenoid being tested.
- Connect negative lead of the ohmmeter to the appropriate solenoid jack (SS-1, SS-2, MCCC) and record resistance.

Refer to following charts for values.

If out of specification, refer to Pinpoint Test A (SS-1,SS-2); Pinpoint Test C (TCC).

**SOLENOID RESISTANCE**

Solenoid	Ohms
SS-1	20-30
SS-2	20-30
TCC	10-16
EPC	2.48-5.66

### Resistance/Continuity Tests—Transmission Fluid Temperature (TFT) Sensor

- Set ohmmeter to 1000 ohm scale.
- Connect ohmmeter positive lead to +TOT jack.
- Connect ohmmeter negative lead to -TOT jack.
- Record resistance. Resistance will vary with temperature.
- Refer to the following chart.

If out of specification, refer to Pinpoint Test B.

**TRANSMISSION FLUID TEMPERATURE**

°C	°F	Resistance (Ohms)
40-20	40-4	967K-284K
19-1	3-31	284K-100K
0-20	32-68	100K-37K
21-40	69-104	37K-16K
41-70	105-158	16K-5K
71-90	159-194	5K-2.7K
91-110	195-230	2.7K-1.5K
111-130	231-266	1.5K-0.8K
131-150	267-302	0.8K-0.54K

### Resistance/Continuity Tests—Output Shaft Speed Sensor (OSS)

- Set ohmmeter to 1000 ohm (K) range.
- Connect the positive lead of the ohmmeter to the +OSS.
- Connect the negative lead of the ohmmeter to the -OSS.
- Record resistance.
- OSS should be 450-750 ohms.

If out of specification, refer to Pinpoint Test F.

### Solenoid Voltage Test

1. Slide MODE switch to BENCH.
2. Set voltmeter to 20 volt D.C.
3. Determine the solenoid you wish to test and connect the voltmeter lead as follows:
  - If testing SS1, SS2 or SS3 solenoid, turn the SOLENOID SELECT dial to SS1, SS2 or SS3 before hooking up leads. If testing EPC or TCC solenoids, continue.

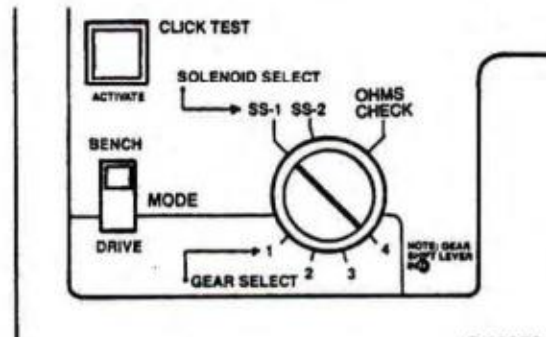

D16383-A

4. Connect the negative lead to the appropriate solenoid jack.
  5. Connect the positive lead to the appropriate VPWR jack.
4. Press the solenoid's ACTIVATE / DEACTIVATE button and check voltage. The LED should light, the voltage should change and an audible click may be heard. See LED status for reading LED status.
  5. Observe and record values.
- LED status:**
- LED turns green when solenoid activates and OFF when deactivated.
- LED turns red if an activated solenoid / harness is shorted to B+.
- LED remains off if an activated solenoid / harness is shorted to ground or no continuity.

### Dynamic Testing—Engine On

Dynamic testing is the final step in the transmission tester usage. It allows the transmission to be proven out electronically and hydraulically.

## DIAGNOSIS AND TESTING (Continued)

### Preliminary Set Up

1. Set BENCH/DRIVE switch to DRIVE mode.
2. Set GEAR SELECT switch to first gear position.
3. Place transmission range selector level in PARK.
4. Start engine.

### EPC Solenoid

1. **CAUTION: Do not attempt to hold the EPC switch depressed (minimum line pressure) and stall the transmission (holding the vehicle with the brake while depressing the throttle with the transmission in gear), as transmission damage will result.**

Observe line pressure. Record value. Line pressure should go to maximum. If not, refer to the Diagnosis by Symptom Routines for diagnostic tips or Pinpoint Test E concerning EPC solenoid.

2. Press EPC switch. Line pressure should drop to a minimum value. Record value. If not, refer to the Diagnosis by Symptom Routines or Pinpoint Test E for the EPC solenoid.

### Transmission Engagements

1. Verify that MODE switch is in DRIVE mode.
2. Turn GEAR SELECT dial to 1.
3. Start engine.
4. Depress EPC switch. Line pressure should drop to idle pressure.

While holding EPC switch down, shift transmission range selector lever from PARK to REVERSE.

- Did vehicle shift into REVERSE?

- Was engagement smooth?

Shift from REVERSE to PARK.

5. Depress EPC switch. Line pressure should drop to idle pressure.

While holding the EPC switch down, shift vehicle from PARK to DRIVE.

- Did vehicle shift into DRIVE?

- Was engagement smooth?

Shift vehicle from DRIVE to PARK.

Release EPC switch. Pressure should return to maximum.

6. With the EPC switch released, repeat Steps 4 and 5, engagements should be firm.

### Upshifts / Downshifts

NOTE: Upshifts and downshifts will be **firm** during this procedure.

NOTE: Pressure gauges may be removed.

NOTE: These tests should be performed on the road. If performed on the hoist, the technician may not feel all shifts when engaged.

LEDs will turn **GREEN** when shift solenoids (7G484) are activated and turn **OFF** when deactivated. Refer to the appropriate overlay for the proper status shift sequence of the shift solenoids during upshifts and downshifts.

1. Shift vehicle into OVERDRIVE and accelerate to 24 km/h (15 mph), select second gear by rotating GEAR SELECT switch to second gear position.

Did vehicle upshift to second gear?

Did appropriate shift solenoids activate / deactivate?

2. Accelerate to 40 km/h (25 mph) and select third gear position.

Did vehicle upshift to third gear?

Did appropriate shift solenoids activate / deactivate?

3. Accelerate to 56-72 km/h (35 / 45 mph) and select fourth gear position.

Did vehicle upshift to fourth gear?

Did appropriate shift solenoids activate / deactivate?

4. Reverse the order to downshift.

Does vehicle downshift from fourth to third, third to second, and second to first?

Did appropriate shift solenoids activate / deactivate?

### Torque Converter Clutch (TCC) Engagement

1. NOTE: This test should be performed on the road. If performed on a hoist, feeling the torque converter clutch engage may not be possible.

**CAUTION: Do not depress MCCC switch with transmission in gear and the vehicle at a stop. Damage to the torque converter clutch may result.**

Accelerate and shift vehicle up into third gear. Hold speed steady and press the MCCC switch.

Does the torque converter engage?

Does the engine rpm drop?

Did torque converter clutch solenoid (TCC solenoid)(7G136) activate?

### Output Shaft Speed (OSS) Sensor Function Check

1. NOTE: This test may be performed on the hoist or on the road.

Set voltmeter to 20 volts AC.

Connect voltmeter positive lead to the (+) OSS jack.

Connect voltmeter negative lead to the (-) OSS jack.

Slowly accelerate vehicle and monitor voltmeter.

Does voltage increase with vehicle speed?

**DIAGNOSIS AND TESTING (Continued)**

After you finish testing, continue to "Transmission Tester Removal and Clearing DTCs" if TR/MLP testing is not required. If TR/MLP testing is required, continue.

**Transmission Range (TR) Sensor Testing**

**Rotunda TR/MLP Sensor Tester Overlay**

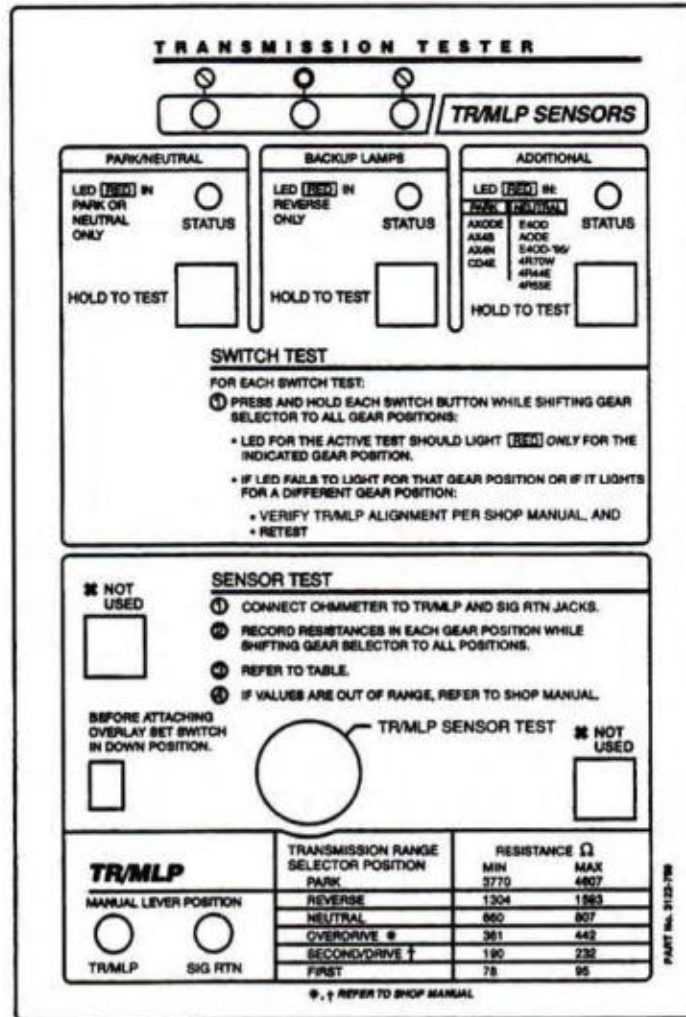

**Introduction**

**CAUTION:** Do not attempt to pry off transmission harness connector with a screwdriver. This will damage the connector and could result in a transmission concern.

The transmission tester allows a technician to operate the electrical portion of the transmission range (TR) sensor. The TR/MLP tester usage is divided into five steps:

1. Preliminary testing and diagnosis.
2. Transmission tester installation (Set-Up Procedure).
3. Testing TR sensor.
4. Park / Neutral, backup lamp and optional circuit voltage tests.
5. Transmission tester removal and clearing diagnostic trouble codes (DTCs).

D14406-B

## DIAGNOSIS AND TESTING (Continued)

### Preliminary Testing and Diagnosis

Before any diagnostic testing is done on a vehicle, some preliminary checks must be performed as described below. Be sure to write down your findings, especially any DTCs found, for future reference.

- Check transmission fluid level and condition.
- Check for add-on items (phones, computers, CB radio, etc).
- Visually inspect wiring harness and connectors.
- Check for vehicle modifications.
- Verify that the shift linkage is properly adjusted in OVERDRIVE.
- Verify that TR Sensor is properly adjusted in NEUTRAL.
- Verify customer concern.
  - Upshift, Downshift, Coasting, Engagement, Noise/Vibration
- Vehicle must be at a normal operating temperature.
- Perform vehicle On-Board Diagnostic.
- Record all DTCs.
- Service all non-transmission DTCs.

### Installation Procedures

Installing the Transmission Tester at the TR Sensor CONNECTOR allows the separation of the vehicle electronics from the TR sensor electronics.

NOTE: During tester usage additional DTCs may be set. Therefore, it is important that all codes are erased after service has been made. To verify elimination of all DTCs, rerun On-Board Diagnostic.

NOTE: The following manuals should be available to assist in diagnosis of electronically-controlled transmissions:

- Powertrain Control/Emissions Diagnosis Manual<sup>9</sup>
- Electrical and Vacuum Troubleshooting Manual (EVTM).

1. **CAUTION: Do not attempt to pry off connectors with a screwdriver. This will damage the connector and could result in a transmission concern.**

Disconnect vehicle harness at transmission TR sensor connector.

2. NOTE: For in-vehicle testing, use the transmission tester extension cable.

**CAUTION: Route all cables away from HEAT SOURCES to prevent damage to cables.**

Set BENCH/DRIVE switch to DRIVE mode. Install TR/MLP sensor overlay onto tester. Connect interface cable Rotunda MLP-C Cable 007-00128 or equivalent to transmission tester and then to the TR sensor connector.

3. Turn test select switch to the TR/MLP SENSOR TEST position.
4. Plug transmission tester power supply plug into cigar lighter.

At this time, all LEDs should illuminate for a short period and then turn off. This is the tester internal circuit check.

Static testing procedures allow for shop testing of the transmission in the vehicle or on the bench. Completion of these tests prove out the TR sensor electronically.

**CAUTION: For resistance checks, be sure that the tester selector switch is set to the TR/MLP SENSOR TEST position or damage to the ohmmeter may result.**

### Resistance/Continuity Tests

1. Set ohmmeter to 1000 ohm range.
2. Connect the positive lead of the ohmmeter to the TR/MLP jack.
3. Connect the negative lead of the ohmmeter to the SIGRTN jack.
4. Move transmission range selector lever into each gear position.
5. Record resistance at each position.
6. Refer to the following chart for values.
7. If out of range, refer to Pinpoint Test D as described.

TR SENSOR RESISTANCE

Transmission Range Selector Lever Position	Resistance (ohms)	
	Minimum	Maximum
PARK	3770	4607
REVERSE	1304	1593
NEUTRAL	660	807
OVERDRIVE <sup>*</sup>	361	442
SECOND/DRIVE <sup>**</sup>	190	232
MANUAL 1	78	95

\* Same values for overdrive or O/D CANCEL (DRIVE) on electronically controlled transmissions. D and Drive (O/D Cancelled) are in the same transmission range selector lever position.

\*\* Same values for SECOND (electronic transmission) or DRIVE on transmissions with a separate DRIVE and OVERDRIVE position.

### Voltage Tests—Park/Neutral, Backup Lamp and Optional Circuits

1. NOTE: LED will turn red when the circuit closes and turn OFF when the circuit is open.  
Tester Select Switch to the TR/MLP SENSOR TEST position.
2. Press and HOLD each button while moving the transmission range selector lever through EACH range.
3. Monitor each LED.
4. The status LED should indicate red only in the indicated position. Refer to overlay.

<sup>9</sup> Can be purchased as a separate item.

## DIAGNOSIS AND TESTING (Continued)

5. If the LED does NOT indicate red in the desired position, or indicates red in another position, first verify TR sensor alignment and then retest. If the sensor fails, then replace.

### Disconnecting The Tester

1. **CAUTION: Do not attempt to pry off connectors with a screwdriver. This will damage the connector and could result in a transmission concern.**

Disconnect transmission tester from the TR Sensor connector.

2. Reinstall vehicle wiring harness. Verify connection by pulling up on the harness.
3. Disconnect transmission tester power lead from vehicle.
4. Erase all DTCs using the procedures in the Powertrain Control/Emissions Diagnosis Manual<sup>10</sup>.
5. Rerun On-Board Diagnostic Tests to receive a pass code.
6. Verify that the customer concern has been eliminated.

## Electrical Schematics

Refer to Electrical and Vacuum Troubleshooting Manual, Cell 29, Transmission Controls for schematic and connector information.

### Transmission Internal Harness

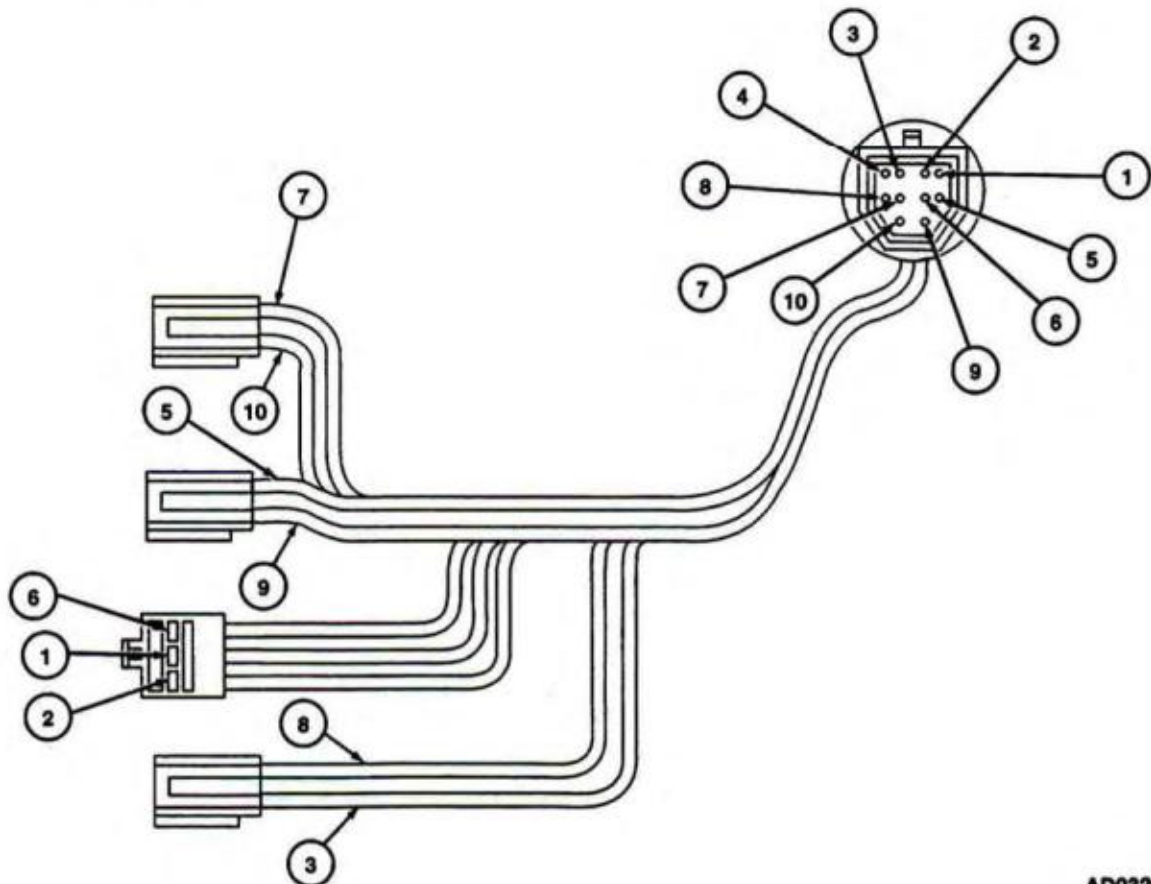

AD0320-B

<sup>10</sup> Can be purchased as a separate item.

## DIAGNOSIS AND TESTING (Continued)

Item	Part Number	Description
1	—	Shift Solenoid No. 1
2	—	Vehicle Power - Shift Solenoid
3	—	Torque Converter Clutch (TCC) Solenoid
4	—	Not Used
5	—	Transmission Fluid Temperature (TFT)

(Continued)

Item	Part Number	Description
6	—	Shift Solenoid No. 2
7	—	Vehicle Power - Electronic Pressure Control (EPC)
8	—	Vehicle Power - Torque Converter Clutch (TCC)
9	—	Signal Return - Transmission Fluid Temperature (TFT)
10	—	Electronic Pressure Control (EPC)

## Transmission Range (TR) Sensor Connector

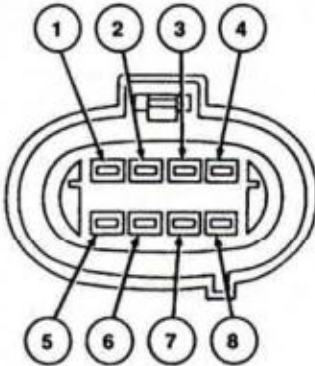

AK0065-A

Pin Number	Circuit	Circuit Function
1	32 (R/LB)	Starter Control
2	298 (P/O)	Fused RUN Only Feed
3	140 (BK/PK)	Back-up Lamp
4	33 (W/PK)	Starter Control to Control Module
5	—	Not Used
6	199 (LB/Y)	Transmission Range (TR) Sensor from PCM
7	359 (GY/R)	Sensor Signal Return
8	—	Not Used

## Transmission Vehicle Harness Connector

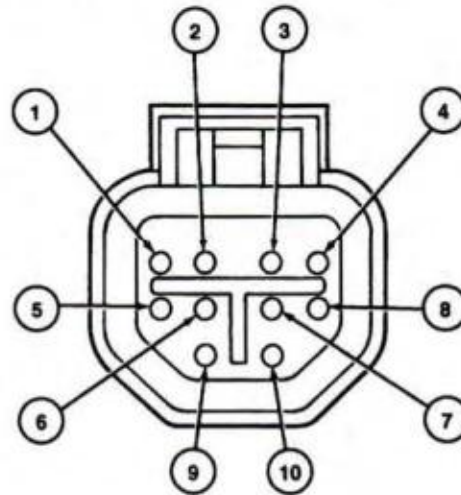

AD0027-A

Pin Number	Circuit	Circuit Function
1	237 (O/Y)	Shift Solenoid 1
2	361 (R)	Vehicle Power
3	480 (P/Y)	Torque Converter Clutch (TCC) Solenoid
4	—	Not Used
5	923 (O/BK)	Transmission Fluid Temperature (TFT) Input
6	315 (P/O)	Shift Solenoid 2
7	361 (R)	Vehicle Power
8	361 (R)	Vehicle Power
9	359 (GY/R)	Signal Return
10	925 (W/Y)	Electronic Pressure Control (EPC) Solenoid

**DIAGNOSIS AND TESTING (Continued)**

**Output Shaft Speed Sensor Connector**

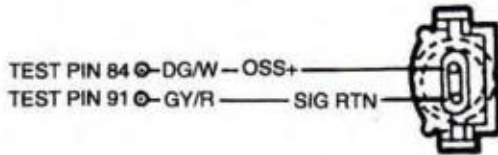

\*TEST PINS LOCATED ON BREAKOUT BOX  
ALL HARNESS CONNECTORS VIEWED INTO  
MATING SURFACE

AD0029-A

**Pinpoint Test A—Shift Solenoids**

REFERENCE: SOLENOID OPERATION CHART #701

Transmission Range Selector Lever Position	PCM Commanded Gear	Solenoids			
		SS-1	SS-2	TCC	
P/R/N	1	ON	OFF	HD	
D	1	ON	OFF	HD	
D	2	OFF	OFF	EC	
D	3	OFF	ON	EC	
D	4	ON	ON	EC	
D w/OD OFF					
1	1	ON	OFF	HD	
2	2	OFF	OFF	EC	
3	3	OFF	ON	EC	
Manual 2	2	OFF	OFF	EC	
Manual 1	1	ON	OFF	HD	
1 <sup>a</sup>	2	OFF	OFF	EC	

a When a manual pull-in occurs above a calibrated speed the transmission will downshift from the higher gear until the vehicle speed drops below this calibrated speed.

EC = Electronically Controlled

HD = Hydraulically Disabled

**Shift Solenoid Failure Modes**

**Shift Solenoid Failure “Always On”**

Failed ON due to powertrain control module (PCM)(12A650) and / or vehicle wiring concerns, shift solenoid (7G484) electrically or hydraulically stuck ON.

SS-1 ALWAYS ON:	Transmission Range Selector Lever Position		
	Ⓣ	2	1
PCM Gear Commanded	Actual Gear Obtained		
1	1	1	1
2	1	1	1
3	4	2 <sup>a</sup>	2 <sup>a</sup>
4	4	2 <sup>a</sup>	2 <sup>a</sup>

a No Engine Braking

SS-2 ALWAYS ON:	Transmission Range Selector Lever Position		
	Ⓣ	2	1
PCM Gear Commanded	Actual Gear Obtained		
1	4	2 <sup>a</sup>	2 <sup>a</sup>
2	3	2 <sup>a</sup>	2 <sup>a</sup>
3	3	2 <sup>a</sup>	2 <sup>a</sup>
4	4	2 <sup>a</sup>	2 <sup>a</sup>

a No Engine Braking

**Shift Solenoid Failure “Always Off”**

Failed OFF due to powertrain control module and / or vehicle wiring concerns, shift solenoid electrically or hydraulically stuck OFF.

SS-1 ALWAYS OFF:	Transmission Range Selector Lever Position		
	Ⓣ	2	1
PCM Gear Commanded	Actual Gear Obtained		
1	2	2	2
2	2	2	2
3	3	2 <sup>a</sup>	2 <sup>a</sup>
4	3	2 <sup>a</sup>	2 <sup>a</sup>

a No Engine Braking

SS-2 ALWAYS OFF:	Transmission Range Selector Lever Position		
	Ⓣ	2	1
PCM Gear Commanded	Actual Gear Obtained		
1	1	1	1
2	2	2	2
3	2	2	2
4	1	1	1

## DIAGNOSIS AND TESTING (Continued)

## PINPOINT TEST A: SHIFT SOLENOIDS

NOTE: Refer to the Transmission Internal Harness illustration preceding these pinpoint tests.

NOTE: Refer to the Transmission Vehicle Harness Connector illustration preceding these pinpoint tests.

Test Step	Result	Action to Take
<b>A1</b> ELECTRONIC DIAGNOSTICS	Yes No	REMAIN in DTM. GO to A2. PRESS START. If vehicle does not enter OTM, refer to PC/ED Manual Output Test Mode NOT FUNCTIONING, Pinpoint Test MB.
<ul style="list-style-type: none"> <li>● Check to make sure the transmission harness connector C1056 is fully seated, terminals are fully engaged in connector and in good condition before proceeding.</li> <li>● Connect Rotunda New Generation Star (NGS) Tester 007-00500 or equivalent.</li> <li>● Perform KOEO test until continuous DTCs have been displayed.</li> <li>● Enter Output Test Mode (OTM). Refer to Special Test Modes as described.</li> <li>● Select the mode ALL ON.</li> <li>● Push START to turn outputs on. Push STOP to turn outputs off.</li> <li>● <b>Does vehicle enter OTM?</b></li> </ul>		
<b>A2</b> CHECK ELECTRICAL SIGNAL OPERATION	Yes No	GO to A5. GO to A3.
<p><b>CAUTION: Do not pry on connector. This will damage the connector and could result in a transmission concern. Pull up on the connector harness.</b></p> <ul style="list-style-type: none"> <li>● Disconnect transmission connector C1056.</li> <li>● Using a mirror, inspect both ends of connector for damage or pushed out pins, corrosion, loose wires and missing or damaged seals.</li> <li>● Connect a voltmeter positive lead to VPWR Pin C1056-2 and the negative test lead to the solenoid circuit of the transmission vehicle harness connector Pins C1056-1 and C1056-6.</li> <li>● Place voltmeter on 20 volt scale.</li> <li>● While observing voltmeter, press START and STOP to cycle solenoid output on and off.</li> <li>● <b>Does the suspect solenoid output voltage change at least 0.5 volt?</b></li> </ul>		
<b>A3</b> CHECK CONTINUITY OF SOLENOID SIGNAL AND VPWR HARNESS CIRCUITS	Yes No	GO to A4. SERVICE OPEN circuits. REMOVE breakout box. RECONNECT all components. REPEAT Quick Tests.
<ul style="list-style-type: none"> <li>● Turn ignition switch to the OFF position.</li> <li>● Make sure transmission harness connector C1056 is disconnected.</li> <li>● Disconnect powertrain control module, inspect for damage or pushed out pins, corrosion or loose wires.</li> <li>● Install Rotunda Breakout Box 014-00950 or equivalent, leave powertrain control module disconnected.</li> <li>● Measure resistance between PCM Signal Test Pins 1 or 27 at breakout box and signal Pins C1056-2 at the transmission harness connector.</li> <li>● Measure resistance between PCM Signal Test Pin 71 and 97 at breakout box and signal pin C1056-2 at the transmission harness connector.</li> <li>● <b>Is each resistance less than 5 ohms?</b></li> </ul>		
<b>A4</b> CHECK SOLENOID HARNESS FOR SHORTS TO POWER AND GROUND	Yes No	GO to A5. SERVICE short circuits. REMOVE breakout box. RECONNECT all components. REPEAT Quick Tests.
<ul style="list-style-type: none"> <li>● Make sure Rotunda Breakout Box 014-00950 or equivalent is installed and powertrain control module disconnected.</li> <li>● Make sure transmission harness connector is disconnected.</li> <li>● Measure resistance between PCM signal output pins 1, 27 and test Pin 71 and 97 at breakout box.</li> <li>● Measure resistance between PCM signal output pins 1, 27 and test Pins 51, 76, 77, 103 and 91 at breakout box and chassis ground.</li> <li>● <b>Is each resistance greater than 10,000 ohms?</b></li> </ul>		

DIAGNOSIS AND TESTING (Continued)

PINPOINT TEST A: SHIFT SOLENOIDS (Continued)

Test Step	Result	Action to Take
<b>A5 TRANSMISSION FUNCTIONAL TEST</b>  <b>CAUTION: Do not attempt to pry connector. This will damage the connector and could result in a transmission concern. Depress tab and pull up on harness connector.</b> <ul style="list-style-type: none"> <li>● Disconnect vehicle harness at transmission.</li> <li>● Install Rotunda Transmission Tester 007-00130 and Rotunda AODE / 4R70W Cable and Overlay 007-00122 or equivalent to transmission connector.</li> <li>● Using tests outlined under Rotunda Transmission Tester, perform transmission solenoid and sensors resistance tests.</li> </ul> <p>NOTE: LED will turn green when solenoid activates and turn OFF when deactivated. LED will turn red if an ACTIVATED solenoid/harness is shorted to battery positive. LED will remain off if an ACTIVATED solenoid/harness is shorted to ground or no continuity (open circuit).</p> <ul style="list-style-type: none"> <li>● Does solenoid (LED GREEN) activate?</li> </ul>	Yes No	GO to A6. GO to A7.
<b>A6 TRANSMISSION DRIVE CYCLE TEST</b> <ul style="list-style-type: none"> <li>● Connect PCM vehicle harness connector to powertrain control module.</li> <li>● Perform the Transmission Drive Cycle Test as described.</li> <li>● Does the vehicle upshift when commanded by the tester?</li> </ul>	Yes  No	REPLACE PCM. ERASE all codes and PERFORM the Drive Cycle Test as described. RE-RUN Quick Test. If DTCs are still present, REFER to Diagnosis by Symptom Routines.  GO to A7.
<b>A7 CHECK RESISTANCE OF SOLENOID/HARNESS</b>  NOTE: Refer to the Transmission Tester for terminal locations. <ul style="list-style-type: none"> <li>● Bench/Drive switch in BENCH mode.</li> <li>● Rotate Gear Select switch to OHMS CHECK position.</li> <li>● Connect ohmmeter negative lead to SS-1 jack and positive lead to VPWR jack on tester. This is to test SS-1.</li> <li>● Record resistance.</li> <li>● Resistance should be between 20 and 30 ohms.</li> <li>● Connect ohmmeter negative lead to SS-2 jack and positive lead to VPWR jack on tester. This is to test SS-2.</li> <li>● Record resistance.</li> <li>● Resistance should be between 20 and 30 ohms.</li> <li>● Is resistance for each solenoid between 20 and 30 ohms?</li> </ul>	Yes No	GO to A8. GO to A9.  NOTE: Out of specification may be caused by internal harness or solenoid concerns.

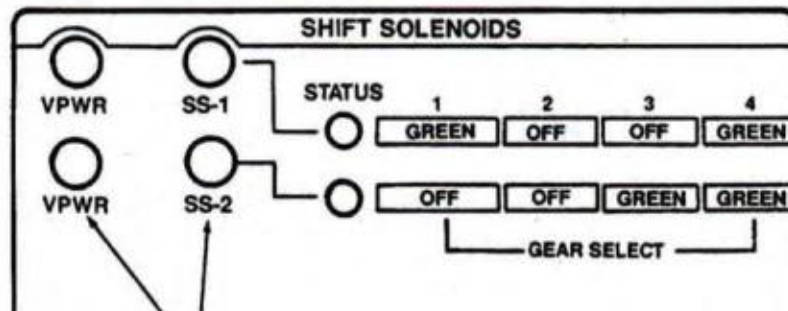

CONNECT OHMMETER BETWEEN THESE TWO JACKS FOR EACH SOLENOID

D12032-A

ProCarManuals.com

**DIAGNOSIS AND TESTING (Continued)**

**PINPOINT TEST A: SHIFT SOLENOIDS (Continued)**

Test Step	Result	Action to Take						
<b>A8</b> CHECK SOLENOID/HARNESS FOR SHORT TO GROUND <ul style="list-style-type: none"> <li>Check for continuity between BAT- jack (engine ground) and appropriate jack with an ohmmeter or other low current tester (less than 200 milliamps).</li> </ul> <table border="1" style="margin-left: 20px;"> <thead> <tr> <th>Solenoid</th> <th>Tester Jack</th> </tr> </thead> <tbody> <tr> <td>SS-1</td> <td>SS-1/VPWR</td> </tr> <tr> <td>SS-2</td> <td>SS-2/VPWR</td> </tr> </tbody> </table> <ul style="list-style-type: none"> <li>Connection should show infinite resistance (no continuity).</li> <li>Is there continuity?</li> </ul>	Solenoid	Tester Jack	SS-1	SS-1/VPWR	SS-2	SS-2/VPWR	Yes No	GO to A9. GO to Diagnosis by Symptom Routines.
Solenoid	Tester Jack							
SS-1	SS-1/VPWR							
SS-2	SS-2/VPWR							

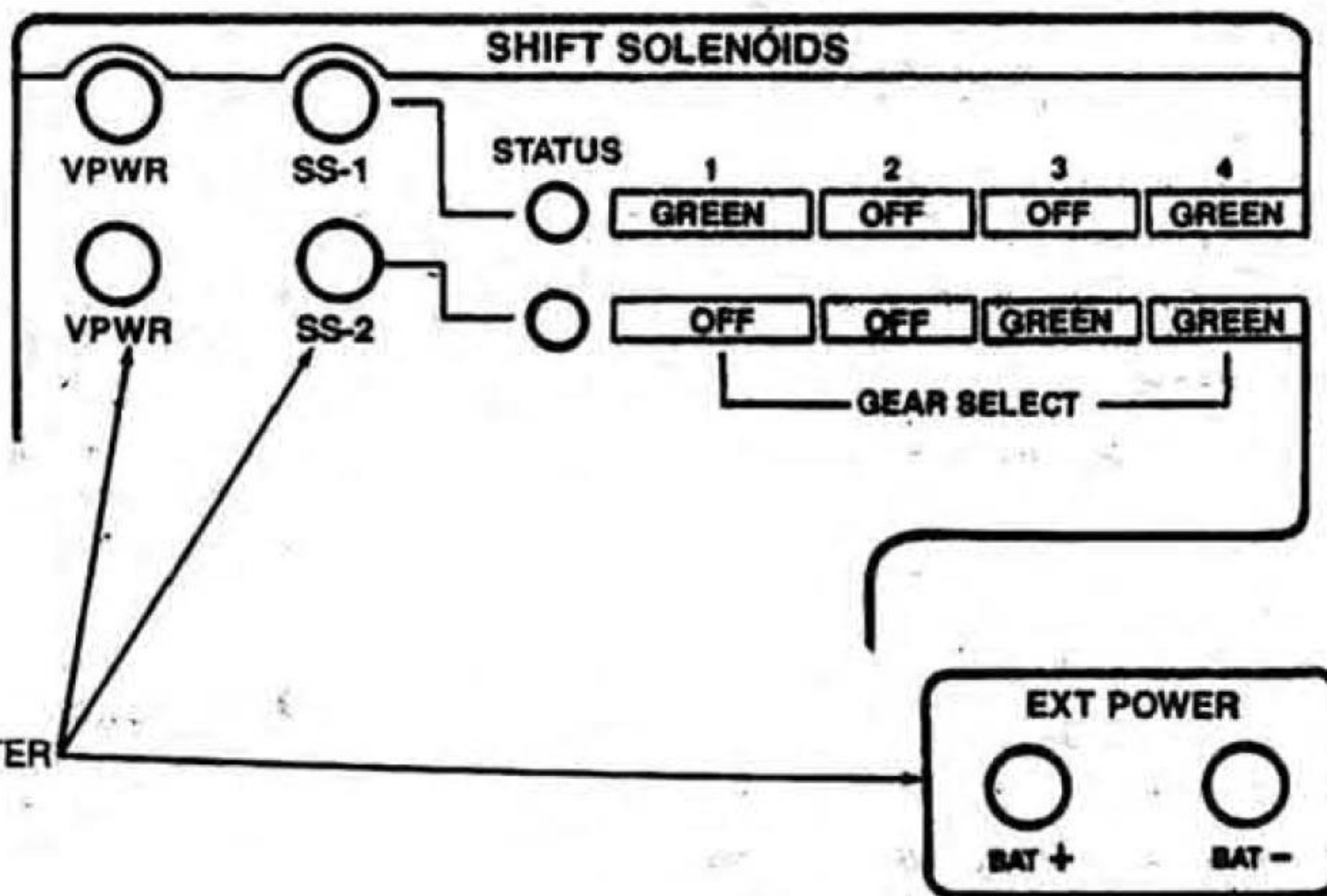

D12033-A

Test Step	Result	Action to Take
<b>A9</b> INTERNAL ELECTRONIC DIAGNOSTICS <ul style="list-style-type: none"> <li>Drain transmission fluid.</li> <li>Remove transmission pan.</li> <li>Check that the internal harness connector is fully engaged on the shift solenoid assembly.</li> <li>Check that the internal harness connector terminals are fully seated in the connector.</li> <li>Inspect the connector for damage.</li> <li>Are above in good condition?</li> </ul>	Yes No	GO to A10. SERVICE as required.

**DIAGNOSIS AND TESTING (Continued)**

**PINPOINT TEST A: SHIFT SOLENOIDS (Continued)**

	Test Step	Result	Action to Take								
<b>A10</b>	<p><b>CHECK INTERNAL HARNESS (CONTINUITY)</b></p> <p><b>CAUTION: Do not probe into connector terminals. This will damage the connector and could result in a transmission concern.</b></p> <ul style="list-style-type: none"> <li>● Disconnect internal harness from solenoid assembly (3-wire connector).</li> <li>● For SS-1, connect the positive lead from an ohmmeter to the tester jack SS-1 and the negative lead at the white wire of the 3-wire connector.</li> <li>● Record resistance. Resistance should be less than 0.5 ohm.</li> <li>● For SS-2, connect the positive lead from an ohmmeter to the tester jack SS-2 and the negative lead at the black wire of the 3-wire connector.</li> <li>● Record resistance. Resistance should be less than 0.5 ohm.</li> <li>● For VPWR, connect positive lead to VPWR and the negative lead to the white / black wire of the 3-wire connector.</li> <li>● Record resistance. Resistance should be less than 0.5 ohm.</li> <li>● <b>Is resistance for each solenoid less than 0.5 ohm?</b></li> </ul>	<p>Yes</p> <p>No</p>	<p>▶ GO to A11.</p> <p>▶ REPLACE internal harness. GO to A12.</p>								
<b>A11</b>	<p><b>CHECK INTERNAL HARNESS (SHORTS TO GROUND)</b></p> <ul style="list-style-type: none"> <li>● Check for continuity between BAT- jack (engine ground) and the appropriate wire with an ohmmeter or other low current tester (less than 200 milliamps).</li> </ul> <table border="1" data-bbox="240 978 849 1119"> <thead> <tr> <th>Solenoid</th> <th>Wire</th> </tr> </thead> <tbody> <tr> <td>SS-1</td> <td>White</td> </tr> <tr> <td>SS-2</td> <td>Black</td> </tr> <tr> <td>VPWR</td> <td>White / Black</td> </tr> </tbody> </table> <ul style="list-style-type: none"> <li>● Connection should show infinite resistance (no continuity).</li> <li>● <b>Does connection show continuity?</b></li> </ul>	Solenoid	Wire	SS-1	White	SS-2	Black	VPWR	White / Black	<p>Yes</p> <p>No</p>	<p>▶ REPLACE internal harness. GO to A12.</p> <p>▶ GO to A12.</p>
Solenoid	Wire										
SS-1	White										
SS-2	Black										
VPWR	White / Black										

ProCarManuals.com

**DIAGNOSIS AND TESTING (Continued)**

**PINPOINT TEST A: SHIFT SOLENOIDS (Continued)**

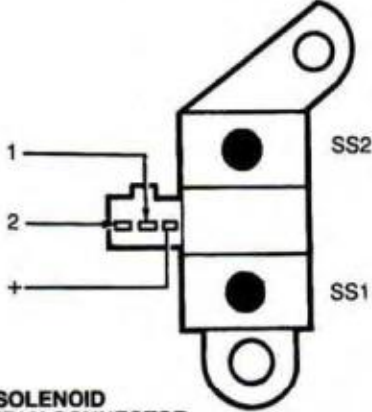
Test Step		Result	Action to Take								
<b>A 12</b>	<b>CHECK SOLENOID RESISTANCE AT SOLENOID</b> <ul style="list-style-type: none"> <li>For SS-1, connect the ohmmeter to the center No. 1 terminal of the solenoid assembly and to the + terminal.</li> <li>Record resistance.</li> <li>Resistance should be between 20 and 30 ohms.</li> <li>For SS-2, check solenoid resistance by connecting an ohmmeter at the outboard No. 2 terminal and + terminal of the solenoid assembly.</li> <li>Record resistance.</li> <li>Resistance should be between 20 and 30 ohms.</li> </ul>  <p><b>SHIFT SOLENOID ASSEMBLY CONNECTOR</b> D10233-C</p> <ul style="list-style-type: none"> <li>Is resistance for each solenoid between 20 and 30 ohms?</li> </ul>	Yes No	GO to A13. REPLACE solenoid assembly.								
<b>A 13</b>	<b>CHECK SOLENOID FOR SHORT TO GROUND</b> <ul style="list-style-type: none"> <li>Check for continuity between BAT- jack (engine ground) and appropriate terminal with ohmmeter or other low current tester (less than 200 milliamps).</li> </ul> <table border="1" data-bbox="126 1224 735 1365"> <thead> <tr> <th>Solenoid</th> <th>Terminal</th> </tr> </thead> <tbody> <tr> <td>SS-1</td> <td>1</td> </tr> <tr> <td>SS-2</td> <td>2</td> </tr> <tr> <td>PWR</td> <td>+</td> </tr> </tbody> </table> <ul style="list-style-type: none"> <li>Connection should show infinite resistance (no continuity).</li> <li>Does connection show continuity?</li> </ul>	Solenoid	Terminal	SS-1	1	SS-2	2	PWR	+	Yes No	REPLACE solenoid assembly. REFER to Diagnosis by Symptom Routines.
Solenoid	Terminal										
SS-1	1										
SS-2	2										
PWR	+										

**PINPOINT TEST B: TRANSMISSION FLUID TEMPERATURE (TFT) SENSOR**

NOTE: Refer to the Transmission Internal Harness illustration preceding these pinpoint tests.

NOTE: Refer to the Transmission Vehicle Harness Connector illustration preceding these pinpoint tests.

Test Step		Result	Action to Take
<b>B 1</b>	<b>ELECTRONIC DIAGNOSTICS</b> <ul style="list-style-type: none"> <li>Check to make sure transmission harness connector C1056 is fully seated, terminals are fully engaged in connector and in good condition before proceeding.</li> <li>Have the items above been checked?</li> </ul>	Yes No	GO to B2. PERFORM checks. ERASE codes. REPEAT Quick Test.

## DIAGNOSIS AND TESTING (Continued)

## PINPOINT TEST B: TRANSMISSION FLUID TEMPERATURE (TFT) SENSOR (Continued)

	Test Step	Result	Action to Take
<b>B2</b>	CHECK ELECTRICAL SIGNAL OPERATION		
	<p><b>CAUTION: Do not pry connector. This will damage the connector and could result in a transmission concern. Pull up on vehicle harness connector.</b></p> <ul style="list-style-type: none"> <li>● Turn ignition switch to the OFF position.</li> <li>● Disconnect transmission connector C1056.</li> <li>● Using a mirror, inspect both ends of the connector for damaged or pushed out pins, corrosion, loose wires and missing or damaged seals.</li> <li>● Connect a voltmeter positive test lead to TFT circuit Pin C1056-5 and negative test lead to Signal Return (SIG RTN) circuit Pin C1056-9 of transmission harness connector.</li> <li>● Place voltmeter on 20 volt scale.</li> <li>● Turn ignition switch to RUN, engine off.</li> <li>● <b>Is voltage between 4.75 and 5.25 volts?</b></li> </ul>	Yes No	GO to <b>B6</b> . GO to <b>B3</b> .
<b>B3</b>	CHECK CONTINUITY OF TFT AND SIG RTN CIRCUITS		
<b>B4</b>	CHECK TFT CIRCUIT FOR SHORT TO VPWR AND GROUND		
	<ul style="list-style-type: none"> <li>● Turn ignition switch to the OFF position.</li> <li>● Make sure that the vehicle harness is disconnected at the transmission connector.</li> <li>● Disconnect powertrain control module. Inspect for damaged or pushed out pins, corrosion or loose wires.</li> <li>● Install Rotunda Breakout Box 014-00950 or equivalent. Leave powertrain control module disconnected.</li> <li>● Measure resistance between PCM signal test Pin 37 at breakout box and signal test pin C1056-5 at transmission harness connector.</li> <li>● Measure resistance between PCM signal test Pin 91 at breakout box and signal test pin C1056-9 at transmission harness connector.</li> <li>● <b>Are both resistances less than 5 ohms?</b></li> </ul>	Yes No	GO to <b>B4</b> . SERVICE open circuits. REMOVE breakout box. RECONNECT all components. ERASE all codes. REPEAT Quick Tests.
	<ul style="list-style-type: none"> <li>● Turn ignition switch to the OFF position.</li> <li>● Make sure transmission harness connector is disconnected.</li> <li>● Disconnect powertrain control module. Inspect for damaged or pushed out pins, corrosion or loose wires.</li> <li>● Install Rotunda Breakout Box 014-00950 or equivalent. Leave powertrain control module disconnected.</li> <li>● Measure resistance between TFT test pin 37 and test Pins 71 and 97 at breakout box.</li> <li>● Measure resistance between TFT test pin 37 and ground test Pins 51, 76, 77, 103 and 91 at breakout box chassis ground.</li> <li>● <b>Is each resistance greater than 10,000 ohms?</b></li> </ul>	Yes No	GO to <b>B5</b> . SERVICE short circuit(s). REMOVE breakout box. RECONNECT all components. ERASE codes. REPEAT Quick Tests.

## DIAGNOSIS AND TESTING (Continued)

## PINPOINT TEST B: TRANSMISSION FLUID TEMPERATURE (TFT) SENSOR (Continued)

Test Step	Result	Action to Take																														
<b>B5</b> CHECK RESISTANCE OF TFT SENSOR/HARNESS																																
<p><b>CAUTION:</b> Do not attempt to pry connector. This will damage the connector and could result in a transmission concern. Depress tab and pull up on harness connector.</p> <p><b>NOTE:</b> Refer to the Transmission Tester for terminal locations.</p> <ul style="list-style-type: none"> <li>Vehicle must be at normal operating temperature.</li> <li>Disconnect vehicle harness connector C1056 at transmission.</li> <li>Install Rotunda Transmission Tester 007-00130 and Rotunda AODE / 4R70W Cable and Overlay 007-00122 or equivalent to transmission connector.</li> <li>Set Bench / Drive switch to BENCH mode.</li> <li>Rotate Gear Select switch to OHMS / DIODE CHECK position.</li> <li>Connect ohmmeter negative lead to -TOT jack and positive lead to +TOT jack on tester.</li> <li>Perform tests 1 and 2.</li> </ul> <p><b>NOTE:</b> While performing Test 1 and 2, observe resistances. DTC P0713 is set if resistance value exceeds 869K ohms (OPEN circuit). DTC P0712 is set if resistance value falls below 597 ohms (short circuit).</p> <ul style="list-style-type: none"> <li><b>Test 1</b> <ul style="list-style-type: none"> <li>Record resistance.</li> <li>Resistance should be approximately in the following ranges:</li> </ul> </li> </ul> <p style="text-align: center;"><b>TRANSMISSION FLUID TEMPERATURE</b></p> <table border="1" style="margin-left: auto; margin-right: auto;"> <thead> <tr> <th>°C</th> <th>°F</th> <th>Resistance (Ohms)</th> </tr> </thead> <tbody> <tr> <td>-40~-20</td> <td>-40~-4</td> <td>967K-284K</td> </tr> <tr> <td>-19~-1</td> <td>3-31</td> <td>284K-100K</td> </tr> <tr> <td>0-20</td> <td>32-68</td> <td>100K-37K</td> </tr> <tr> <td>21-40</td> <td>69-104</td> <td>37K-16K</td> </tr> <tr> <td>41-70</td> <td>105-158</td> <td>16K-5K</td> </tr> <tr> <td>71-90</td> <td>159-194</td> <td>5K-2.7K</td> </tr> <tr> <td>91-110</td> <td>195-230</td> <td>2.7K-1.5K</td> </tr> <tr> <td>111-130</td> <td>231-266</td> <td>1.5K-0.8K</td> </tr> <tr> <td>131-150</td> <td>267-302</td> <td>0.8K-0.54K</td> </tr> </tbody> </table> <ul style="list-style-type: none"> <li><b>Test 2</b> <ul style="list-style-type: none"> <li>Check for intermittent short or open.</li> <li>If resistance was between 0.8K and 100K ohms, perform following test. If transmission is warm, allow transmission to cool. Check transmission fluid temperature sensor resistance again. Compare resistance with initial resistance. Resistance should decrease if transmission was heated and should increase if transmission was allowed to cool. If correct change in resistance occurs, REPEAT On-Board Diagnostic.</li> </ul> </li> <li><b>Is resistance in range?</b></li> </ul>	°C	°F	Resistance (Ohms)	-40~-20	-40~-4	967K-284K	-19~-1	3-31	284K-100K	0-20	32-68	100K-37K	21-40	69-104	37K-16K	41-70	105-158	16K-5K	71-90	159-194	5K-2.7K	91-110	195-230	2.7K-1.5K	111-130	231-266	1.5K-0.8K	131-150	267-302	0.8K-0.54K	<p>Yes</p> <p>No</p>	<p>GO to B6.</p> <p>GO to B7.</p>
°C	°F	Resistance (Ohms)																														
-40~-20	-40~-4	967K-284K																														
-19~-1	3-31	284K-100K																														
0-20	32-68	100K-37K																														
21-40	69-104	37K-16K																														
41-70	105-158	16K-5K																														
71-90	159-194	5K-2.7K																														
91-110	195-230	2.7K-1.5K																														
111-130	231-266	1.5K-0.8K																														
131-150	267-302	0.8K-0.54K																														

## DIAGNOSIS AND TESTING (Continued)

## PINPOINT TEST B: TRANSMISSION FLUID TEMPERATURE (TFT) SENSOR (Continued)

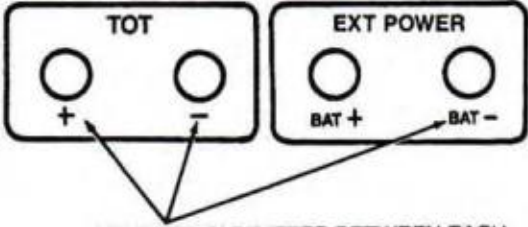
Test Step	Result	Action to Take
<p><b>B6</b> CHECK TFT SENSOR/HARNESS FOR SHORT TO GROUND</p> <ul style="list-style-type: none"> <li>● Check for continuity between BAT- jack (engine ground) and appropriate jack (-TOT and +TOT) with ohmmeter or other low current tester (less than 200 milliamps).</li> <li>● Connection should show infinite resistance (no continuity).</li> <li>● <b>Is there continuity?</b></li> </ul>  <p>CONNECT OHMMETER BETWEEN EACH TOT JACK AND BAT (-) JACK</p> <p>D12036-A</p>	<p>Yes</p> <p>No</p>	<p>▶ GO to B7.</p> <p>▶ REPLACE PCM. REPEAT On-Board Diagnostics. If DTCs are still present, GO to B7.</p>
<p><b>B7</b> INTERNAL ELECTRONIC DIAGNOSTICS</p> <ul style="list-style-type: none"> <li>● Drain transmission fluid.</li> <li>● Remove transmission pan.</li> <li>● Check that internal harness connector is fully engaged on transmission fluid temperature sensor.</li> <li>● Check that internal harness connector terminals are fully seated in connector.</li> <li>● Inspect the connector for damage.</li> <li>● <b>Are above in good condition?</b></li> </ul>	<p>Yes</p> <p>No</p>	<p>▶ GO to B8.</p> <p>▶ SERVICE as required.</p>
<p><b>B8</b> CHECK INTERNAL HARNESS (CONTINUITY)</p> <p><b>CAUTION: Do not probe into connector terminals. This will damage the connector and could result in a transmission concern.</b></p> <ul style="list-style-type: none"> <li>● Disconnect internal harness from transmission fluid temperature sensor.</li> <li>● For transmission fluid temperature sensor, connect the positive lead from an ohmmeter to the tester +TOT jack and the negative lead at the white/red wire of the TFT sensor connector.</li> <li>● Record resistance. Resistance should be less than 0.5 ohm.</li> <li>● Connect the positive lead from an ohmmeter to the tester -TOT jack and the negative lead at the red wire of the TFT wire connector.</li> <li>● Record resistance. Resistance should be less than 0.5 ohm.</li> <li>● <b>Is resistance less than 0.5 ohm?</b></li> </ul>	<p>Yes</p> <p>No</p>	<p>▶ GO to B9.</p> <p>▶ REPLACE internal harness. GO to B10.</p>

## DIAGNOSIS AND TESTING (Continued)

## PINPOINT TEST B: TRANSMISSION FLUID TEMPERATURE (TFT) SENSOR (Continued)

Test Step	Result	Action to Take																														
<b>B9</b> CHECK INTERNAL HARNESS (SHORTS TO GROUND) <ul style="list-style-type: none"> <li>Check for continuity between BAT- jack (engine ground) and the appropriate wire (+TFT and -TFT) with ohmmeter or other low current tester (less than 200 milliamps).</li> </ul> <table border="1"> <thead> <tr> <th>Sensor</th> <th>Wire</th> </tr> </thead> <tbody> <tr> <td>TFT+</td> <td>White / Red</td> </tr> <tr> <td>TFT-</td> <td>Red</td> </tr> </tbody> </table> <ul style="list-style-type: none"> <li>Connection should show infinite resistance (no continuity).</li> <li><b>Is there continuity?</b></li> </ul>	Sensor	Wire	TFT+	White / Red	TFT-	Red	Yes No	REPLACE internal harness. GO to B10. GO to B10.																								
Sensor	Wire																															
TFT+	White / Red																															
TFT-	Red																															
<b>B10</b> CHECK TFT SENSOR RESISTANCE <ul style="list-style-type: none"> <li>Check sensor resistance by connecting an ohmmeter at the terminals of the transmission fluid temperature sensor assembly.</li> <li>Record resistance.</li> <li>Resistance should be in range of temperature of the vehicle.</li> <li>Resistance should be approximately in the following ranges:</li> </ul> <p style="text-align: center;"><b>TRANSMISSION FLUID TEMPERATURE</b></p> <table border="1"> <thead> <tr> <th>°C</th> <th>°F</th> <th>Resistance (Ohms)</th> </tr> </thead> <tbody> <tr> <td>-40~-20</td> <td>-40~-4</td> <td>967K-264K</td> </tr> <tr> <td>-19~-1</td> <td>-3~31</td> <td>284K-100K</td> </tr> <tr> <td>0-20</td> <td>32-68</td> <td>100K-37K</td> </tr> <tr> <td>21-40</td> <td>69-104</td> <td>37K-16K</td> </tr> <tr> <td>41-70</td> <td>105-158</td> <td>16K-5K</td> </tr> <tr> <td>71-90</td> <td>159-194</td> <td>5K-2.7K</td> </tr> <tr> <td>91-110</td> <td>195-230</td> <td>2.7K-1.5K</td> </tr> <tr> <td>111-130</td> <td>231-266</td> <td>1.5K-0.8K</td> </tr> <tr> <td>131-150</td> <td>267-302</td> <td>0.8K-0.54K</td> </tr> </tbody> </table> <ul style="list-style-type: none"> <li><b>Is resistance in range?</b></li> </ul>	°C	°F	Resistance (Ohms)	-40~-20	-40~-4	967K-264K	-19~-1	-3~31	284K-100K	0-20	32-68	100K-37K	21-40	69-104	37K-16K	41-70	105-158	16K-5K	71-90	159-194	5K-2.7K	91-110	195-230	2.7K-1.5K	111-130	231-266	1.5K-0.8K	131-150	267-302	0.8K-0.54K	Yes No	GO to B11. REPLACE transmission fluid temperature sensor.
°C	°F	Resistance (Ohms)																														
-40~-20	-40~-4	967K-264K																														
-19~-1	-3~31	284K-100K																														
0-20	32-68	100K-37K																														
21-40	69-104	37K-16K																														
41-70	105-158	16K-5K																														
71-90	159-194	5K-2.7K																														
91-110	195-230	2.7K-1.5K																														
111-130	231-266	1.5K-0.8K																														
131-150	267-302	0.8K-0.54K																														
<b>B11</b> CHECK TFT SENSOR FOR SHORT TO GROUND <ul style="list-style-type: none"> <li>Check for continuity between engine ground and appropriate terminal with ohmmeter or other low current tester (less than 200 milliamps).</li> </ul> <table border="1"> <thead> <tr> <th>Sensor</th> <th>Terminal</th> </tr> </thead> <tbody> <tr> <td>TFT</td> <td>+/-</td> </tr> </tbody> </table> <ul style="list-style-type: none"> <li>Connection should show infinite resistance (no continuity).</li> <li><b>Is there continuity?</b></li> </ul>	Sensor	Terminal	TFT	+/-	Yes No	REPLACE transmission fluid temperature sensor. REPEAT Quick Test. If codes are present and overtemp condition existed, CHECK fluid condition. CHECK overheat condition in the Diagnosis by Symptom Routine. SERVICE as required. REPEAT Quick Test.																										
Sensor	Terminal																															
TFT	+/-																															

## DIAGNOSIS AND TESTING (Continued)

## PINPOINT TEST C: TORQUE CONVERTER CLUTCH (TCC) SOLENOID

NOTE: Refer to the Transmission Internal Harness illustration preceding these pinpoint tests.

NOTE: Refer to the Transmission Vehicle Harness Connector Illustration preceding these pinpoint tests.

Test Step		Result	Action to Take
<b>C1</b>	<b>ELECTRONIC DIAGNOSTICS</b>		
	<ul style="list-style-type: none"> <li>● Check to make sure the transmission harness connector C1056 is fully seated, terminals are fully engaged in connector and in good condition before proceeding.</li> <li>● Connect Rotunda New Generation Star (NGS) Tester 007-00500 or equivalent.</li> <li>● Perform KOEO test until continuous DTCs have been displayed.</li> <li>● Enter Output Test Mode (OTM). Refer to Special Test Modes as described.</li> <li>● Select the mode ALL ON.</li> <li>● Push START to turn outputs on. Push STOP to turn outputs off.</li> <li>● <b>Does vehicle enter OTM?</b></li> </ul>	Yes No	▶ REMAIN in DTM. GO to C2. ▶ PRESS START. If vehicle does not enter OTM, refer to PC/ED Manual Output Test Mode NOT FUNCTIONING, Pinpoint Test MB.
<b>C2</b>	<b>CHECK ELECTRICAL SIGNAL OPERATION</b>		
	<ul style="list-style-type: none"> <li>● Disconnect transmission connector C1056.</li> <li>● Using a mirror, inspect both ends of the connector for damaged or pushed out pins, corrosion, loose wires and missing or damaged seals.</li> <li>● Connect a voltmeter positive lead to VPWR Pin C1056-8 and the negative test lead to the solenoid circuit of the transmission vehicle harness connector Pin C1056-3.</li> <li>● Place voltmeter on 20 volt scale.</li> <li>● While observing voltmeter, press START and STOP to cycle solenoid output on and off.</li> <li>● <b>Does the suspect solenoid output voltage change at least 0.5 volt?</b></li> </ul>	Yes No	▶ GO to C5. ▶ GO to C3.
<b>C3</b>	<b>CHECK CONTINUITY OF SOLENOID SIGNAL AND VPWR HARNESS CIRCUITS</b>		
	<ul style="list-style-type: none"> <li>● Turn ignition switch to the OFF position.</li> <li>● Make sure transmission harness connector C1056 is disconnected.</li> <li>● Disconnect powertrain control module, inspect for damaged or pushed out pins, corrosion or loose wires.</li> <li>● Install Rotunda Breakout Box 014-00950 or equivalent, leaving powertrain control module disconnected.</li> <li>● Measure resistance between PCM signal output test Pin 54 at the breakout box and the signal pin C1056-3 at the transmission harness connector.</li> <li>● Measure resistance between PCM power test Pins 71 and 97 at breakout box and the power pin C1056-8 at the transmission harness connector.</li> <li>● <b>Is each resistance less than 5 ohms?</b></li> </ul>	Yes No	▶ GO to C4. ▶ SERVICE open circuits. REMOVE breakout box. RECONNECT all components. REPEAT Quick Tests.
<b>C4</b>	<b>CHECK SOLENOID HARNESS FOR SHORTS TO POWER AND GROUND</b>		
	<ul style="list-style-type: none"> <li>● Make sure Rotunda Breakout Box 014-00950 or equivalent is installed and powertrain control module disconnected.</li> <li>● Make sure transmission harness connector C1056 is disconnected.</li> <li>● Measure resistance between PCM signal output pin 54 and test Pins 71 and 97 at breakout box.</li> <li>● Measure resistance between PCM signal output test pin 54 and test Pins 51, 76, 77, 103 and 91 at breakout box and chassis ground.</li> <li>● <b>Is each resistance greater than 10,000 ohms?</b></li> </ul>	Yes No	▶ GO to C7. ▶ SERVICE short circuit(s). REMOVE breakout box. RECONNECT all components. REPEAT Quick Tests.

## DIAGNOSIS AND TESTING (Continued)

## PINPOINT TEST C: TORQUE CONVERTER CLUTCH (TCC) SOLENOID (Continued)

Test Step	Result	Action to Take
<b>C5</b> TRANSMISSION FUNCTIONAL TEST		
<p><b>CAUTION: Do not pry connector. This will damage the connector and could result in a transmission concern. Press the tab and pull on vehicle harness connector.</b></p> <ul style="list-style-type: none"> <li>● Disconnect vehicle harness at transmission.</li> <li>● Install Rotunda Transmission Tester 007-00130 and Rotunda AODE / 4R70W Cable and Overlay 007-00122 or equivalent to transmission connector.</li> <li>● Using tests outlined under Tester instructions, perform torque converter clutch solenoid function test.</li> </ul> <p>NOTE: LED will turn green when torque converter clutch solenoid activates and turn OFF when deactivated. LED will turn red if an ACTIVATED solenoid / harness is shorted to battery positive. LED will remain off if an ACTIVATED solenoid / harness is shorted to ground or no continuity (open circuit).</p> <ul style="list-style-type: none"> <li>● Does MCCC (LED GREEN) activate when tester switch is pressed?</li> </ul>	<p>Yes</p> <p>No</p>	<p>▶ GO to C6.</p> <p>▶ GO to C7.</p>
<b>C6</b> TRANSMISSION DRIVE CYCLE TEST		
<ul style="list-style-type: none"> <li>● Connect PCM vehicle harness connector to powertrain control module.</li> <li>● Perform Transmission Drive Cycle Test as described.</li> <li>● While in second gear press the MCCC switch.</li> <li>● Does the torque converter clutch solenoid activate (LED green)?</li> </ul> <p>Does the engine rpm drop?</p>	<p>Yes</p> <p>No</p>	<p>▶ REPLACE PCM. ERASE all DTCs. Road test, RERUN on-board diagnostic tests. If symptoms persists, REFER to Diagnosis by Symptom—Torque Converter Concerns.</p> <p>▶ GO to C7.</p>
<b>C7</b> CHECK RESISTANCE OF SOLENOID / HARNESS		
<p>NOTE: Refer to transmission tester for terminal locations.</p> <ul style="list-style-type: none"> <li>● Set Bench / Drive switch to BENCH mode.</li> <li>● Rotate Gear Select switch to OHMS CHECK position.</li> <li>● Connect ohmmeter negative lead to MCCC jack and positive lead to VPWR on tester.</li> </ul> <p>This is to test torque converter clutch solenoid.</p> <ul style="list-style-type: none"> <li>● Record resistance.</li> <li>● Resistance should be between 10 and 16 ohms.</li> <li>● Is resistance between 10 and 16 ohms?</li> </ul>	<p>Yes</p> <p>No</p>	<p>▶ GO to C8.</p> <p>▶ GO to C9.</p> <p>NOTE: Internal harness or torque converter clutch solenoid may be damaged.</p>

DIAGNOSIS AND TESTING (Continued)

PINPOINT TEST C: TORQUE CONVERTER CLUTCH (TCC) SOLENOID (Continued)

Test Step	Result	Action to Take				
<p><b>C8</b> CHECK SOLENOID/HARNESS FOR SHORT TO GROUND</p> <ul style="list-style-type: none"> <li>Check for continuity between BAT- jack (engine ground) and appropriate jack with an ohmmeter or other low current tester (less than 200 milliamps).</li> </ul> <table border="1" style="margin-left: 20px;"> <thead> <tr> <th>Solenoid</th> <th>Tester Jack</th> </tr> </thead> <tbody> <tr> <td>TCC</td> <td>MCCC</td> </tr> </tbody> </table> <ul style="list-style-type: none"> <li>Connection should infinite resistance (no continuity).</li> <li><b>Is there continuity?</b></li> </ul>	Solenoid	Tester Jack	TCC	MCCC	<p>Yes</p> <p>No</p>	<p>▶ GO to C9.</p> <p>▶ REFER to Diagnosis by Symptom Routines.</p>
Solenoid	Tester Jack					
TCC	MCCC					

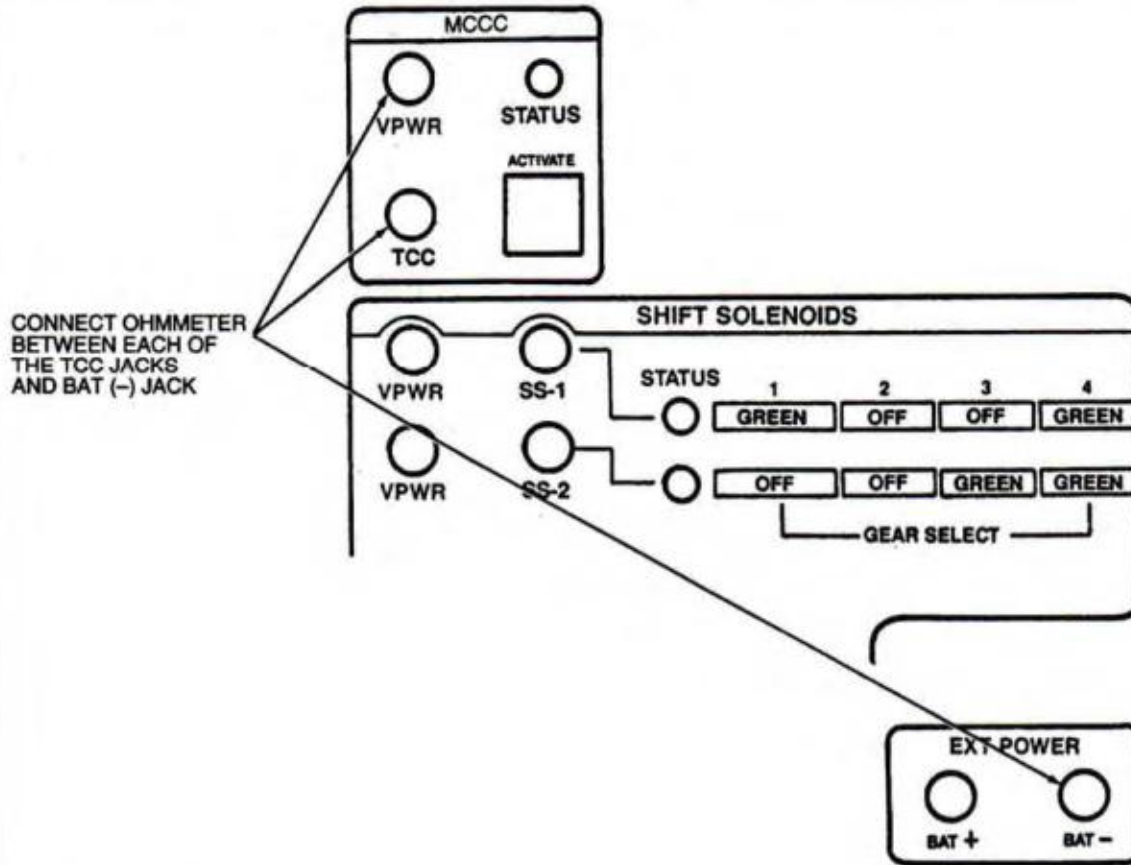

D12038-B

<p><b>C9</b> INTERNAL ELECTRONIC DIAGNOSTICS</p> <ul style="list-style-type: none"> <li>Drain transmission fluid.</li> <li>Remove transmission pan.</li> <li>Check that internal harness connector is fully engaged on the torque converter clutch solenoid assembly.</li> <li>Check that internal harness connector terminals are fully seated in the connector.</li> <li>Inspect the connector for damage.</li> <li><b>Are above in good condition and engaged properly?</b></li> </ul>	<p>Yes</p> <p>No</p>	<p>▶ GO to C10.</p> <p>▶ SERVICE as required.</p>
---	----------------------	---

## DIAGNOSIS AND TESTING (Continued)

## PINPOINT TEST C: TORQUE CONVERTER CLUTCH (TCC) SOLENOID (Continued)

Test Step		Result	Action to Take						
<b>C10</b>	<b>CHECK INTERNAL HARNESS (CONTINUITY)</b>								
	<p><b>CAUTION: Do not probe into connector terminals. This will damage the connector and could result in a transmission concern.</b></p> <ul style="list-style-type: none"> <li>● Disconnect internal harness from torque converter clutch solenoid assembly (TCC wire connector).</li> <li>● Connect positive lead from an ohmmeter to tester MCCC jack and the negative lead at the green wire of the TCC connector.</li> <li>● Record resistance. Resistance should be less than 0.5 ohm.</li> <li>● Connect the positive lead from an ohmmeter to the tester VPWR jack and the negative lead to the white / green wire of the TCC connector.</li> <li>● Record resistance. Resistance should be less than 0.5 ohm.</li> <li>● <b>Is resistance less than 0.5 ohm?</b></li> </ul>	Yes No	► GO to C11. ► REPLACE internal harness. GO to C12.						
<b>C11</b>	<b>CHECK INTERNAL HARNESS (SHORTS TO GROUND)</b>								
	<ul style="list-style-type: none"> <li>● Check for continuity between BAT- jack (engine ground) and the appropriate wire with an ohmmeter or other low current tester (less than 200 milliamps).</li> </ul> <table border="1" data-bbox="126 842 737 942"> <thead> <tr> <th>Solenoid</th> <th>Wire</th> </tr> </thead> <tbody> <tr> <td>TCC</td> <td>Green</td> </tr> <tr> <td>White / Green</td> <td></td> </tr> </tbody> </table> <ul style="list-style-type: none"> <li>● Connection should show infinite resistance (no continuity).</li> <li>● <b>Is there continuity?</b></li> </ul>	Solenoid	Wire	TCC	Green	White / Green		Yes No	► REPLACE internal harness. GO to C12. ► GO to C12.
Solenoid	Wire								
TCC	Green								
White / Green									
<b>C12</b>	<b>CHECK SOLENOID RESISTANCE</b>								
	<ul style="list-style-type: none"> <li>● For TCC, check solenoid resistance by connecting an ohmmeter to the terminals of the torque converter clutch solenoid assembly.</li> <li>● Record resistance.</li> <li>● Resistance should be between 10 and 16 ohms.</li> <li>● <b>Is resistance between 10 and 16 ohms?</b></li> </ul>	Yes No	► GO to C13. ► REPLACE torque converter clutch solenoid assembly.						

DIAGNOSIS AND TESTING (Continued)

PINPOINT TEST C: TORQUE CONVERTER CLUTCH (TCC) SOLENOID (Continued)

Test Step	Result	Action to Take				
<p><b>C13</b> CHECK SOLENOID FOR SHORT TO GROUND</p> <ul style="list-style-type: none"> <li>Check for continuity between BAT- jack (engine ground) and appropriate solenoid terminals with ohmmeter or other low current tester (less than 200 milliamps).</li> </ul> <table border="1" style="margin-left: 20px;"> <thead> <tr> <th>Solenoid</th> <th>Terminal</th> </tr> </thead> <tbody> <tr> <td>TCC</td> <td>+/-</td> </tr> </tbody> </table> <ul style="list-style-type: none"> <li>Connection should show infinite resistance (no continuity).</li> <li>Is there continuity?</li> </ul>	Solenoid	Terminal	TCC	+/-	<p>Yes</p> <p>No</p>	<p>REPLACE torque converter clutch solenoid assembly.</p> <p>REFER to Diagnosis by Symptom Routines—Torque Converter Concerns.</p>
Solenoid	Terminal					
TCC	+/-					

Rotunda TR/MLP Sensor Tester Overlay

**TRANSMISSION TESTER**

**TR/MLP SENSORS**

**PARK/NEUTRAL**

LED **[RED]** IN PARK OR NEUTRAL ONLY

STATUS

HOLD TO TEST

**BACKUP LAMPS**

LED **[RED]** IN REVERSE ONLY

STATUS

HOLD TO TEST

**ADDITIONAL**

LED **[RED]** IN:

PARK	NEUTRAL
AX00E	E400
AX48	A00C
AX9H	E40D-95
CD4E	4R70W
	4R44E
	4R55E

STATUS

HOLD TO TEST

**SWITCH TEST**

FOR EACH SWITCH TEST:

- PRESS AND HOLD EACH SWITCH BUTTON WHILE SHIFTING GEAR SELECTOR TO ALL GEAR POSITIONS:

- LED FOR THE ACTIVE TEST SHOULD LIGHT **[RED]** ONLY FOR THE INDICATED GEAR POSITION.
- IF LED FAILS TO LIGHT FOR THAT GEAR POSITION OR IF IT LIGHTS FOR A DIFFERENT GEAR POSITION:
  - VERIFY TR/MLP ALIGNMENT PER SHOP MANUAL, AND
  - RETEST

**SENSOR TEST**

NOT USED

- CONNECT OHMMETER TO TR/MLP AND SIG RTH JACKS.
- RECORD RESISTANCES IN EACH GEAR POSITION WHILE SHIFTING GEAR SELECTOR TO ALL POSITIONS.
- REFER TO TABLE.
- IF VALUES ARE OUT OF RANGE, REFER TO SHOP MANUAL.

BEFORE ATTACHING OVERLAY SET SWITCH IN DOWN POSITION.

TR/MLP SENSOR TEST

NOT USED

TRANSMISSION RANGE SELECTOR POSITION	RESISTANCE $\Omega$	
	MIN	MAX
PARK	3770	4607
REVERSE	1304	1983
NEUTRAL	850	807
OVERDRIVE *	351	442
SECOND/DRIVE †	190	239
FIRST	75	95

\*, † REFER TO SHOP MANUAL

**TR/MLP**

MANUAL LEVER POSITION

TR/MLP
  SIG RTH

PART NO. 9132-709

D14406-B

## DIAGNOSIS AND TESTING (Continued)

## PINPOINT TEST D: TRANSMISSION RANGE (TR) SENSOR

NOTE: Refer to the Transmission Range (TR) Sensor Connector illustration preceding these pinpoint tests.

Test Step	Result	Action to Take
<b>D1</b> TR SENSOR ELECTRONIC DIAGNOSTICS <ul style="list-style-type: none"> <li>● Check to make sure TR sensor harness connector C1057 is fully seated, terminals are fully engaged in connector and in good condition before proceeding.</li> <li>● Verify shift linkage adjustment in the OVERDRIVE position.</li> <li>● Turn ignition switch to the OFF position.</li> <li>● Apply parking brake.</li> <li>● Place transmission in NEUTRAL.</li> <li>● Verify that Transmission Range (TR) Sensor (MLPS) Alignment Tool T93P-70010-A or equivalent fits in the appropriate slots.</li> <li>● <b>Is the sensor properly adjusted?</b></li> </ul>	Yes No	REMOVE tool. GO to D2. ADJUST sensor as described under Transmission Assembly. After adjustments, PLACE transmission range selector lever in PARK. CLEAR DTC and REPEAT Quick-Test.
<b>D2</b> CHECK ELECTRICAL SIGNAL OPERATION <p><b>CAUTION: Do not pry on connector. This will damage the connector and could result in a transmission concern. Pull up on vehicle harness connector.</b></p> <ul style="list-style-type: none"> <li>● Turn ignition switch to the OFF position.</li> <li>● Place transmission range selector lever in PARK.</li> <li>● Disconnect TR sensor connector C1057.</li> <li>● Using a mirror, inspect both ends of the connector for damaged or pushed out pins, corrosion, loose wires and missing or damaged seals.</li> <li>● Connect a voltmeter positive test lead to TR circuit Pin C1057-6 and negative test lead to Signal Return (SIG RTN) circuit C1057-7 of TR sensor harness connector.</li> <li>● Place voltmeter on 20 volt scale.</li> <li>● Turn ignition switch ON, engine OFF.</li> <li>● <b>Is reference voltage (VREF) between 4.75 and 5.25 volts?</b></li> </ul>	Yes No	GO to D5. GO to D3.
<b>D3</b> CHECK CONTINUITY OF TR SENSOR HARNESS CIRCUITS <p><b>CAUTION: Do not pry connector. This will damage the connector and could result in a transmission concern. Press button and pull up on vehicle harness.</b></p> <ul style="list-style-type: none"> <li>● Turn ignition switch to the OFF position.</li> <li>● Disconnect TR sensor connector C1057.</li> <li>● Inspect for damage or pushed out pins, corrosion or loose wires.</li> <li>● Install Rotunda Breakout Box 014-00950 or equivalent. Leave PCM disconnected.</li> <li>● Disconnect powertrain control module. Inspect for damaged or pushed out pins, corrosion or loose wires.</li> <li>● Measure resistance between PCM test Pin 91 at breakout box and SIG RTN circuit Pin C1057-7 at TR sensor vehicle harness connector.</li> <li>● Measure resistance between PCM test Pin 64 at breakout box and TR signal circuit C1057-6 at TR sensor vehicle harness connector.</li> <li>● <b>Is each resistance less than 5 ohms?</b></li> </ul>	Yes No	GO to D4. SERVICE open circuit(s). REMOVE breakout box. RECONNECT all components. ERASE codes. REPEAT Quick Test.

**DIAGNOSIS AND TESTING (Continued)**

**PINPOINT TEST D: TRANSMISSION RANGE (TR) SENSOR (Continued)**

Test Step		Result	Action to Take																												
<b>D4</b>	<b>CHECK TR SENSOR CIRCUIT FOR SHORTS TO POWER AND GROUND</b>	Yes	<ul style="list-style-type: none"> <li>▶ GO to <b>D5</b>.</li> <li>▶ SERVICE short circuit. REMOVE breakout box. RECONNECT all components. ERASE codes. REPEAT Quick Test.</li> </ul>																												
	<ul style="list-style-type: none"> <li>● Make sure Rotunda Breakout Box 014-00950 or equivalent is installed and PCM disconnected.</li> <li>● Make sure TR sensor harness connector is disconnected.</li> <li>● Measure resistance between PCM test Pin 64, and test pins 71, 97.</li> <li>● Measure resistance between PCM test Pin 64 and test Pins 51, 76, 77, 103 and 91 at breakout box and chassis ground.</li> <li>● <b>Is each resistance greater than 10,000 ohms?</b></li> </ul>	No																													
<b>D5</b>	<b>CHECK OPERATION OF TR SENSOR</b>	Yes	<ul style="list-style-type: none"> <li>▶ If you were diagnosing a NO VREF concern, REPLACE PCM. Then GO to <b>D6</b>.</li> <li>▶ REPLACE TR sensor and ADJUST. REFER to transmission assembly section. ERASE codes and REPEAT Quick Test.</li> </ul>																												
	<ul style="list-style-type: none"> <li>● Disconnect TR sensor harness connector C1057 at the transmission.</li> <li>● Connect Rotunda Transmission Tester 007-00130 with Transmission Range (TR) Sensor Cable (MLP-C Cable) 007-00128 or equivalent to TR sensor.</li> <li>● Using procedures provided with tester, verify TR sensor functions in all positions.</li> <li>● Check continuity and resistance in all positions.</li> </ul> <p><b>TR SENSOR RESISTANCE RANGE</b></p> <table border="1"> <thead> <tr> <th rowspan="2">Transmission Range Selector Lever Position</th> <th colspan="2">Resistance (ohms)</th> <th rowspan="2">Range Volts</th> </tr> <tr> <th>Min</th> <th>Max</th> </tr> </thead> <tbody> <tr> <td>P</td> <td>3770</td> <td>4607</td> <td>3.97-4.85</td> </tr> <tr> <td>R</td> <td>1304</td> <td>1593</td> <td>3.24-3.96</td> </tr> <tr> <td>N</td> <td>680</td> <td>807</td> <td>2.55-3.11</td> </tr> <tr> <td>OD</td> <td>361</td> <td>442</td> <td>1.88-2.30</td> </tr> <tr> <td>2</td> <td>190</td> <td>232</td> <td>1.23-1.51</td> </tr> <tr> <td>1</td> <td>78</td> <td>95</td> <td>0.61-0.75</td> </tr> </tbody> </table> <ul style="list-style-type: none"> <li>● <b>Are the resistance values within specification?</b></li> </ul>	Transmission Range Selector Lever Position		Resistance (ohms)		Range Volts	Min	Max	P	3770	4607	3.97-4.85	R	1304	1593	3.24-3.96	N	680	807	2.55-3.11	OD	361	442	1.88-2.30	2	190	232	1.23-1.51	1	78	95
Transmission Range Selector Lever Position	Resistance (ohms)		Range Volts																												
	Min	Max																													
P	3770	4607	3.97-4.85																												
R	1304	1593	3.24-3.96																												
N	680	807	2.55-3.11																												
OD	361	442	1.88-2.30																												
2	190	232	1.23-1.51																												
1	78	95	0.61-0.75																												
<b>D6</b>	<b>CHECK PARK / NEUTRAL CIRCUITS OF SENSOR</b>	Yes	<ul style="list-style-type: none"> <li>▶ GO to <b>D7</b>. If diagnosing a park / neutral circuit or starting system concern, REFER to Section 03-06.</li> <li>▶ REPLACE TR sensor and adjust. REFER to installation and adjustment procedures. ERASE DTCs and REPEAT Quick Tests.</li> </ul>																												
	<ul style="list-style-type: none"> <li>● Using the procedures outlined in the tester manual, check the park / neutral circuits of the sensor in all gear positions.</li> <li>● Monitor the status lamp on the tester for proper indications.</li> </ul> <table border="1"> <thead> <tr> <th>Circuit</th> <th>Transmission Range Selector Lever Position</th> <th>Resistance</th> </tr> </thead> <tbody> <tr> <td rowspan="6">33 (W / PK) and 32 (R / LB)</td> <td>P</td> <td>Less than 5.0 Ohms</td> </tr> <tr> <td>R</td> <td>Greater than 100K Ohms</td> </tr> <tr> <td>N</td> <td>Less than 5.0 Ohms</td> </tr> <tr> <td>⊕</td> <td>Greater than 100K Ohms</td> </tr> <tr> <td>D</td> <td>Greater than 100K Ohms</td> </tr> <tr> <td>1</td> <td>Greater than 100K Ohms</td> </tr> </tbody> </table> <ul style="list-style-type: none"> <li>● <b>Do the park / neutral circuits operate properly and only in the proper gear position?</b></li> </ul>	Circuit		Transmission Range Selector Lever Position	Resistance	33 (W / PK) and 32 (R / LB)	P	Less than 5.0 Ohms	R	Greater than 100K Ohms	N	Less than 5.0 Ohms	⊕	Greater than 100K Ohms	D	Greater than 100K Ohms	1	Greater than 100K Ohms	No												
Circuit	Transmission Range Selector Lever Position	Resistance																													
33 (W / PK) and 32 (R / LB)	P	Less than 5.0 Ohms																													
	R	Greater than 100K Ohms																													
	N	Less than 5.0 Ohms																													
	⊕	Greater than 100K Ohms																													
	D	Greater than 100K Ohms																													
	1	Greater than 100K Ohms																													

**DIAGNOSIS AND TESTING (Continued)**

**PINPOINT TEST D: TRANSMISSION RANGE (TR) SENSOR (Continued)**

Test Step		Result	Action to Take																
<b>D7</b>	<b>CHECK REVERSE / BACKUP LAMP CIRCUITS OF SENSOR</b>																		
<ul style="list-style-type: none"> <li>Using the procedures outlined in the tester manual, check the reverse / backup circuits of the sensor in all gear positions.</li> <li>Monitor the status lamp on the tester for proper indications.</li> </ul>		Yes  No	<ul style="list-style-type: none"> <li>If diagnosing a backup circuit concern, REFER to Section 17-01.</li> <li>REPLACE TR sensor and adjust. REFER to installation and adjustment procedures. ERASE DTCs and REPEAT Quick Tests.</li> </ul>																
<table border="1"> <thead> <tr> <th>Circuit</th> <th>Transmission Range Selector Lever Position</th> <th>Resistance</th> </tr> </thead> <tbody> <tr> <td rowspan="6">298 (P/O) and 140 (BK/PK)</td> <td>P</td> <td>Greater than 100K Ohms</td> </tr> <tr> <td>R</td> <td>Less than 5.0 Ohms</td> </tr> <tr> <td>N</td> <td>Greater than 100K Ohms</td> </tr> <tr> <td>⊙</td> <td>Greater than 100K Ohms</td> </tr> <tr> <td>D</td> <td>Greater than 100K Ohms</td> </tr> <tr> <td>1</td> <td>Greater than 100K Ohms</td> </tr> </tbody> </table>		Circuit	Transmission Range Selector Lever Position	Resistance	298 (P/O) and 140 (BK/PK)	P	Greater than 100K Ohms	R	Less than 5.0 Ohms	N	Greater than 100K Ohms	⊙	Greater than 100K Ohms	D	Greater than 100K Ohms	1	Greater than 100K Ohms		
Circuit	Transmission Range Selector Lever Position	Resistance																	
298 (P/O) and 140 (BK/PK)	P	Greater than 100K Ohms																	
	R	Less than 5.0 Ohms																	
	N	Greater than 100K Ohms																	
	⊙	Greater than 100K Ohms																	
	D	Greater than 100K Ohms																	
	1	Greater than 100K Ohms																	
<ul style="list-style-type: none"> <li>Do the reverse / backup circuits operate properly and only in the proper gear position?</li> </ul>																			

**PINPOINT TEST E: ELECTRONIC PRESSURE CONTROL (EPC) SOLENOID**

NOTE: Refer to the Transmission Internal Harness Illustration preceding these pinpoint tests.

NOTE: Refer to the Transmission Vehicle Harness Connector Illustration preceding these pinpoint tests.

Test Step		Result	Action to Take
<b>E1</b>	<b>4R70W ELECTRONIC DIAGNOSTICS</b>		
<ul style="list-style-type: none"> <li>Check to make sure transmission harness connector C1056 is fully seated, terminals are fully engaged in connector and in good condition before proceeding.</li> <li>Connect New Generation Star (NGS) Tester 007-00500 or equivalent to transmission vehicle harness connector.</li> <li>Perform KOEO Test until continuous DTCs have been displayed.</li> <li>Enter Output Test Mode (OTM).</li> <li>Select the mode ALL ON.</li> <li>Push START to turn outputs on. Push STOP to turn outputs off.</li> <li>Does vehicle enter OTM?</li> </ul>		Yes  No	<ul style="list-style-type: none"> <li>REMAIN in DTM. GO to E2.</li> <li>PRESS START. If vehicle does not enter OTM, refer to PC / ED Manual Output Test Mode NOT FUNCTIONING, Pinpoint Test MB.</li> </ul>

ProCarManuals.com

## DIAGNOSIS AND TESTING (Continued)

## PINPOINT TEST E: ELECTRONIC PRESSURE CONTROL (EPC) SOLENOID (Continued)

	Test Step	Result	Action to Take
<b>E2</b>	CHECK ELECTRICAL SIGNAL OPERATION		
	<p><b>CAUTION: Do not pry on connector. This will damage the connector and could result in a transmission concern. Press button and pull up on transmission harness connector.</b></p> <ul style="list-style-type: none"> <li>● Disconnect transmission vehicle harness connector C1056.</li> <li>● Using a mirror, inspect both ends of connector for damage or pushed out pins, corrosion, loose wires and missing or damaged seals.</li> <li>● Connect a voltmeter positive lead to VPWR Pin C1056-7 and the negative lead to the solenoid circuit of the transmission vehicle harness connector Pin C1056-10.</li> <li>● Place voltmeter on 20 volt scale.</li> <li>● While observing voltmeter, press START and STOP throttle to cycle solenoid output on and off.</li> <li>● <b>Does the suspect solenoid output voltage change at least 0.5 volt?</b></li> </ul>	Yes No	► GO to E5. ► GO to E3.
<b>E3</b>	CHECK CONTINUITY OF SOLENOID SIGNAL AND VPWR HARNESS CIRCUITS		
	<ul style="list-style-type: none"> <li>● Turn ignition switch to the OFF position.</li> <li>● Disconnect powertrain control module. Inspect for damaged or pushed out pins, corrosion or loose wires.</li> <li>● Install Rotunda Breakout Box 014-00950 or equivalent. Leave PCM disconnected.</li> <li>● Measure resistance between PCM test Pins 71 and 97 at breakout box and EPC PWR circuit Pin C1056-7 at transmission harness connector.</li> <li>● Measure resistance between PCM test Pin 81 at breakout box and EPC signal pin C1056-10 at transmission harness connector.</li> <li>● <b>Is each resistance less than 5 ohms?</b></li> </ul>	Yes No	► GO to E4. ► SERVICE open circuit(s). REMOVE breakout box. RECONNECT all components. ERASE codes and REPEAT On-Board Diagnostic Tests.
<b>E4</b>	CHECK HARNESS FOR SHORT TO POWER AND GROUND		
	<ul style="list-style-type: none"> <li>● Turn ignition switch to the OFF position.</li> <li>● Ensure Rotunda Breakout Box 014-00950 or equivalent is installed, PCM is disconnected.</li> <li>● Ensure transmission connector is disconnected.</li> <li>● Measure resistance between EPC circuit PCM test Pin 81 and test Pins 71 and 97 at breakout box.</li> <li>● Measure resistance between EPC circuit PCM test Pins 81 and test Pins 51, 76, 77, 103 and 91 at breakout box.</li> <li>● <b>Is each resistance greater than 10,000 ohms?</b></li> </ul>	Yes No	► GO to E5. ► SERVICE short circuit(s). RECONNECT all components. ERASE codes and REPEAT On-Board Diagnostic Tests.

## DIAGNOSIS AND TESTING (Continued)

## PINPOINT TEST E: ELECTRONIC PRESSURE CONTROL (EPC) SOLENOID (Continued)

Test Step	Result	Action to Take
<p><b>E5</b> TRANSMISSION FUNCTIONAL TEST</p> <p><b>CAUTION:</b> Do not attempt to pry the connector. This will damage the connector and could result in a transmission concern. Depress tab and pull up on harness connector.</p> <ul style="list-style-type: none"> <li>● Connect PCM vehicle harness connector to powertrain control module.</li> <li>● Disconnect vehicle harness at transmission.</li> <li>● Install line pressure gauge at line tap on case.</li> <li>● Install Rotunda Transmission Tester 007-00130 and Rotunda AODE/4R70W Cable and Overlay 007-00122 or equivalent to transmission connector.</li> <li>● Set BENCH/DRIVE switch to DRIVE mode.</li> <li>● Rotate GEAR SELECT switch to first gear position.</li> <li>● Using tests outlined under Transmission Tester Instructions, perform the Transmission Solenoids and Sensors Resistance Tests.</li> </ul> <p>NOTE: LED will turn green when EPC solenoid activates and turn OFF when deactivated. LED will turn red if an ACTIVATED solenoid/harness is shorted to battery positive voltage (B+). LED will remain off if an ACTIVATED solenoid/harness is shorted to ground or no continuity (open circuit).</p> <ul style="list-style-type: none"> <li>— Does the EPC (LED green) activate when EPC switch is pressed?</li> <li>— Observe line pressure on the gauge while pressing EPC switch (engine must be running).</li> <li>● Does the line pressure drop?</li> </ul>	<p>Yes</p> <p>No</p>	<p>REPLACE powertrain control module. INSPECT PCM relay. SERVICE as required.</p> <p>GO to E6.</p>
<p><b>E6</b> CHECK RESISTANCE OF SOLENOID/HARNESS</p> <p>NOTE: Refer to the Transmission Tester for terminal locations.</p> <ul style="list-style-type: none"> <li>● Set Bench/Drive switch to BENCH mode.</li> <li>● Rotate Gear Select switch to OHMS CHECK position.</li> <li>● Connect ohmmeter negative lead to VPWR jack and positive lead to EPC jack on tester. This is to test EPC solenoid.</li> <li>● Record resistance.</li> <li>● Resistance should be between 2.48 and 5.66 ohms.</li> <li>● Is resistance between 2.48 and 5.66 ohms?</li> </ul>	<p>Yes</p> <p>No</p>	<p>GO to E7.</p> <p>GO to E8.</p> <p>NOTE: Out of specification may be caused by internal harness or EPC solenoid concerns.</p>

DIAGNOSIS AND TESTING (Continued)

PINPOINT TEST E: ELECTRONIC PRESSURE CONTROL (EPC) SOLENOID (Continued)

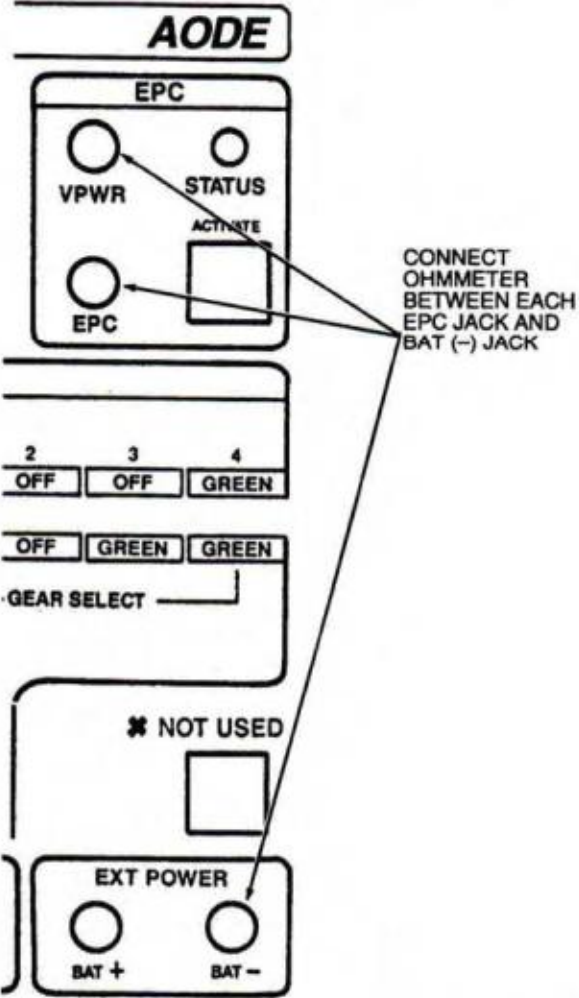
Test Step	Result	Action to Take						
<p><b>E7</b> CHECK SOLENOID/HARNESS FOR SHORT TO GROUND</p> <ul style="list-style-type: none"> <li>Check for continuity between BAT- jack (engine ground) and appropriate jack with an ohmmeter or other low current tester (less than 200 milliamps).</li> </ul> <table border="1" data-bbox="228 436 837 541"> <thead> <tr> <th>Solenoid</th> <th>Tester Jack</th> </tr> </thead> <tbody> <tr> <td>EPC</td> <td>EPC</td> </tr> <tr> <td>VPWR</td> <td></td> </tr> </tbody> </table> <ul style="list-style-type: none"> <li>Connection should show infinite resistance (no continuity).</li> <li>Is there continuity?</li> </ul>  <p style="text-align: center;">D12042-A</p>	Solenoid	Tester Jack	EPC	EPC	VPWR		<p>Yes</p> <p>No</p>	<p>▶ GO to E8.</p> <p>▶ REFER to Diagnosis by Symptom Routines.</p>
Solenoid	Tester Jack							
EPC	EPC							
VPWR								
<p><b>E8</b> INTERNAL ELECTRONIC DIAGNOSTICS</p> <ul style="list-style-type: none"> <li>Drain transmission fluid.</li> <li>Remove transmission pan.</li> <li>Check that internal harness connector is fully engaged on EPC solenoid assembly.</li> <li>Check that internal harness connector terminals are fully seated in connector.</li> <li>Inspect connector for damage.</li> <li>Are above properly engaged and in good condition?</li> </ul>	<p>Yes</p> <p>No</p>	<p>▶ GO to E9.</p> <p>▶ SERVICE as required.</p>						

ProCarManuals.com

## DIAGNOSIS AND TESTING (Continued)

## PINPOINT TEST E: ELECTRONIC PRESSURE CONTROL (EPC) SOLENOID (Continued)

Test Step		Result	Action to Take						
<b>E9</b>	<b>CHECK INTERNAL HARNESS (CONTINUITY)</b>								
	<ul style="list-style-type: none"> <li>Disconnect internal harness from EPC solenoid assembly.</li> <li>Connect the positive lead from an ohmmeter to the tester EPC jack and the negative lead at the blue wire at the EPC wire connector.</li> <li>Record resistance. Resistance should be less than 0.5 ohm.</li> <li>Connect the positive lead from an ohmmeter to the tester VPWR jack and the negative lead at the white / blue wire at the EPC wire connector.</li> <li>Record resistance. Resistance should be less than 0.5 ohm.</li> <li><b>Is resistance less than 0.5 ohm?</b></li> </ul>	Yes No	GO to E10. REPLACE internal harness. GO to E11.						
<b>E10</b>	<b>CHECK INTERNAL HARNESS (SHORTS TO GROUND)</b>								
	<ul style="list-style-type: none"> <li>Check for continuity between BAT- jack (engine ground) and the appropriate wire with an ohmmeter or other low current tester (less than 200 milliamps).</li> </ul> <table border="1"> <thead> <tr> <th>Solenoid</th> <th>Wire</th> </tr> </thead> <tbody> <tr> <td>EPC</td> <td>Blue (Signal)</td> </tr> <tr> <td>White / Blue (EPC VPWR)</td> <td></td> </tr> </tbody> </table> <ul style="list-style-type: none"> <li>Connection should show infinite resistance (no continuity).</li> <li><b>Is there continuity?</b></li> </ul>	Solenoid	Wire	EPC	Blue (Signal)	White / Blue (EPC VPWR)		Yes No	REPLACE internal harness. GO to E11. GO to E11.
Solenoid	Wire								
EPC	Blue (Signal)								
White / Blue (EPC VPWR)									
<b>E11</b>	<b>CHECK SOLENOID RESISTANCE</b>								
	<ul style="list-style-type: none"> <li>Check solenoid resistance by connecting an ohmmeter at the EPC solenoid terminals of the solenoid.</li> <li>Record resistance.</li> <li>Resistance should be between 2.48 and 5.66 ohms.</li> <li><b>Is resistance between 2.48 and 5.66 ohms?</b></li> </ul>	Yes No	GO to E12. REPLACE EPC solenoid.						
<b>E12</b>	<b>CHECK SOLENOID FOR SHORT TO GROUND</b>								
	<ul style="list-style-type: none"> <li>Check for continuity between BAT- jack (engine ground) and appropriate terminal with ohmmeter or other low current tester (less than 200 milliamps).</li> </ul> <table border="1"> <thead> <tr> <th>Solenoid</th> <th>Terminal</th> </tr> </thead> <tbody> <tr> <td>EPC</td> <td>+/-</td> </tr> </tbody> </table> <ul style="list-style-type: none"> <li>Connection should show infinite resistance (no continuity).</li> <li><b>Is there continuity?</b></li> </ul>	Solenoid	Terminal	EPC	+/-	Yes No	REPLACE EPC solenoid. REFER to Diagnosis by Symptom Routines.		
Solenoid	Terminal								
EPC	+/-								

## PINPOINT TEST F: OUTPUT SHAFT SPEED (OSS) SENSOR

NOTE: Refer to the Output Shaft Speed Sensor Connector illustration preceding these pinpoint tests.

Test Step		Result	Action to Take
<b>F1</b>	<b>ELECTRONIC DIAGNOSTICS</b>		
	<ul style="list-style-type: none"> <li>Check that the output shaft speed sensor connector C1058 is fully seated, terminals are fully engaged in the connector and in good condition.</li> <li><b>Have the items above been checked?</b></li> </ul>	Yes No	GO to F2. PERFORM the checks. ERASE codes. RERUN On-Board Diagnostic Tests.

## DIAGNOSIS AND TESTING (Continued)

## PINPOINT TEST F: OUTPUT SHAFT SPEED (OSS) SENSOR (Continued)

Test Step	Result	Action to Take
<b>F2</b> CHECK CONTINUITY OF OSS HARNESS CIRCUITS		
<p><b>CAUTION: Do not pry on connector. This will damage the connector and could result in a transmission concern. Pull up on vehicle harness.</b></p> <ul style="list-style-type: none"> <li>Turn ignition switch to the OFF position.</li> <li>Disconnect OSS connector C1058.</li> <li>Disconnect powertrain control module. Inspect for damaged or pushed out pins, corrosion or loose wires.</li> <li>Install Rotunda Breakout Box 014-00950 or equivalent, leaving powertrain control module disconnected.</li> <li>Measure resistance between PCM test Pin 84 at breakout box and OSS(+) signal Circuit 970 (DG/W) at the OSS harness connector.</li> <li>Measure resistance between PCM test Pin 91 at breakout box and OSS(-) signal Circuit 359 (GY/R) at the OSS harness connector.</li> <li><b>Is each resistance less than 5 ohms?</b></li> </ul>	<p>Yes</p> <p>No</p>	<p>▶ GO to F3.</p> <p>▶ SERVICE open circuit(s). REMOVE breakout box. RECONNECT all components. ERASE codes. RERUN On-Board Diagnostic Tests.</p>
<b>F3</b> CHECK OSS CIRCUITS FOR SHORT TO POWER AND GROUND		
<ul style="list-style-type: none"> <li>Turn ignition switch to the OFF position.</li> <li>OSS disconnected.</li> <li>Breakout box installed, PCM disconnected.</li> <li>Measure resistance between PCM test Pins 84, 91 and test Pins 71 and 97 at breakout box.</li> <li>Measure resistance between PCM test Pins 84 and 91 and test Pins 51, 76, 77 and 103 at breakout box.</li> <li><b>Is each resistance greater than 10,000 ohms?</b></li> </ul>	<p>Yes</p> <p>No</p>	<p>▶ GO to F4.</p> <p>▶ SERVICE short circuit(s). REMOVE breakout box. RECONNECT all components. ERASE codes and RERUN On-Board Diagnostic tests.</p>
<b>F4</b> TRANSMISSION FUNCTIONAL TEST		
<p><b>CAUTION: Do not attempt to pry on the connector. This will damage the connector and could result in a transmission concern. Pull on harness connector.</b></p> <ul style="list-style-type: none"> <li>Connect PCM vehicle harness connector to powertrain control module.</li> <li>Disconnect vehicle harness at OSS sensor.</li> <li>Install Rotunda Transmission Tester 007-00130 and Rotunda AODE/4R70W Cable and Overlay 007-00122 or equivalent onto output shaft speed sensor.</li> <li>Connect voltmeter positive lead to +OSS and the negative lead to -OSS. Set voltmeter to AC.</li> <li>Perform OSS Function Test. Monitor voltmeter.</li> <li><b>Does the voltage increase with an increase in vehicle speed?</b></li> </ul>	<p>Yes</p> <p>No</p>	<p>▶ REPLACE PCM.</p> <p>▶ GO to F5.</p>
<b>F5</b> CHECK RESISTANCE OF OUTPUT SHAFT SPEED SENSOR		
<p>NOTE: Refer to the Transmission Tester for terminal locations.</p> <ul style="list-style-type: none"> <li>Connect ohmmeter negative lead to +OSS jack and positive lead to -OSS jack on tester. This is to test OSS sensor.</li> <li>Record resistance. Resistance should be between 450 and 750 ohms.</li> <li><b>Is resistance between 450 and 750 ohms?</b></li> </ul>	<p>Yes</p> <p>No</p>	<p>▶ GO to F6.</p> <p>▶ REPLACE OSS sensor. RERUN OSS Function Test.</p>

## DIAGNOSIS AND TESTING (Continued)

## PINPOINT TEST F: OUTPUT SHAFT SPEED (OSS) SENSOR (Continued)

Test Step		Result	Action to Take						
<b>F6</b>	<b>CHECK SENSOR FOR SHORT TO GROUND</b>								
<ul style="list-style-type: none"> <li>Check for continuity between BAT- jack (engine ground) and appropriate jack with an ohmmeter or other low current tester (less than 200 milliamps).</li> </ul> <table border="1" data-bbox="133 415 740 516"> <thead> <tr> <th>Solenoid</th> <th>Tester Jack</th> </tr> </thead> <tbody> <tr> <td>OSS</td> <td>+OSS</td> </tr> <tr> <td>-OSS</td> <td></td> </tr> </tbody> </table> <ul style="list-style-type: none"> <li>Connection should show infinite resistance (no continuity).</li> <li><b>Is there continuity?</b></li> </ul>		Solenoid	Tester Jack	OSS	+OSS	-OSS		Yes No	REPLACE OSS sensor. RERUN OSS Function Test. GO to F7.
Solenoid	Tester Jack								
OSS	+OSS								
-OSS									

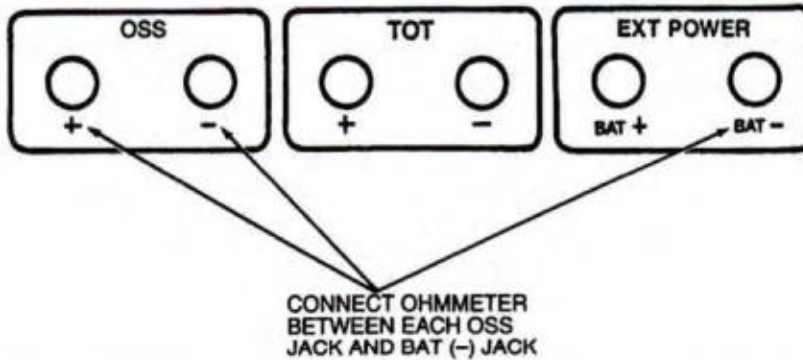

D12044-A

<b>F7</b>	<b>CHECK OSS MAGNETISM</b>	Yes No	GO to F8. REPLACE OSS sensor. RERUN OSS Function Test.
<ul style="list-style-type: none"> <li>Remove OSS sensor from transmission.</li> <li>Place OSS sensor against a metal surface to which a magnet would stick. The OSS sensor should be magnetized and stick to the metal surface.</li> <li><b>Does OSS stick?</b></li> </ul>			
<b>F8</b>	<b>CHECK OUTPUT SHAFT RING GEAR</b>	Yes No	REPLACE OSS sensor. RERUN OSS Function Test. REFER to Disassembly and Assembly to service output shaft ring gear. SERVICE or REPLACE as required.
<ul style="list-style-type: none"> <li>With OSS sensor removed and transmission in NEUTRAL, rotate driveshaft and observe through the OSS sensor hole in case that all six holes or indentations in the ring gear are present and free of foreign material.</li> <li><b>Are holes present and free of foreign material?</b></li> </ul>			

## Pinpoint Test G

Test does not apply.

## PINPOINT TEST H: SOLENOID MECHANICAL FAILURE

Test Step		Result	Action to Take
<b>H1</b>	<b>ELECTRONIC DIAGNOSTIC</b>		
NOTE: Service all other DTCs before servicing the following DTCs P1714, P1715, P1716, P1717, P1740.		Yes No	SERVICE the DTCs for TFT or shift solenoids first. CLEAR DTCs and PERFORM transmission drive cycle test. RERUN quick test. REPLACE the appropriate solenoid and/or body. REFER to the DTC chart for code description. GO to H2.
<ul style="list-style-type: none"> <li>If any of the following DTCs P1714, P1715, P1716, P1717, P1740 are present continue with test.</li> <li><b>Are other DTCs present for TFT or shift solenoids?</b></li> </ul>			

**DIAGNOSIS AND TESTING (Continued)**

**PINPOINT TEST H: SOLENOID MECHANICAL FAILURE (Continued)**

Test Step	Result	Action to Take
<b>H2 TRANSMISSION DRIVE CYCLE TEST</b> ● Perform transmission drive cycle test. ● Perform on board diagnostic quick test. ● Does the vehicle upshift and/or downshift OK?	Yes No	GO to H3. REFER to Diagnosis by Symptom to diagnose shift concerns.
<b>H3 DTC CODES</b> ● Check for DTCs retrieved during quick test. ● Are DTCs P1714, P1715, P1716, P1717, P1740 still present?	Yes No	REPLACE powertrain control module. Road Test and RERUN Quick Test. Testing completed. If concern still exists, REFER to the Diagnosis by Symptom chart for concerns diagnosis.

**Special Testing Procedures**

**Engine Idle Speed Check**

Refer to the Powertrain Control / Emissions Diagnosis Manual<sup>11</sup> for the appropriate procedure.

**Line Pressure Test**

This test verifies that the line pressure is within specification.

1. Connect pressure gauge to line pressure tap.

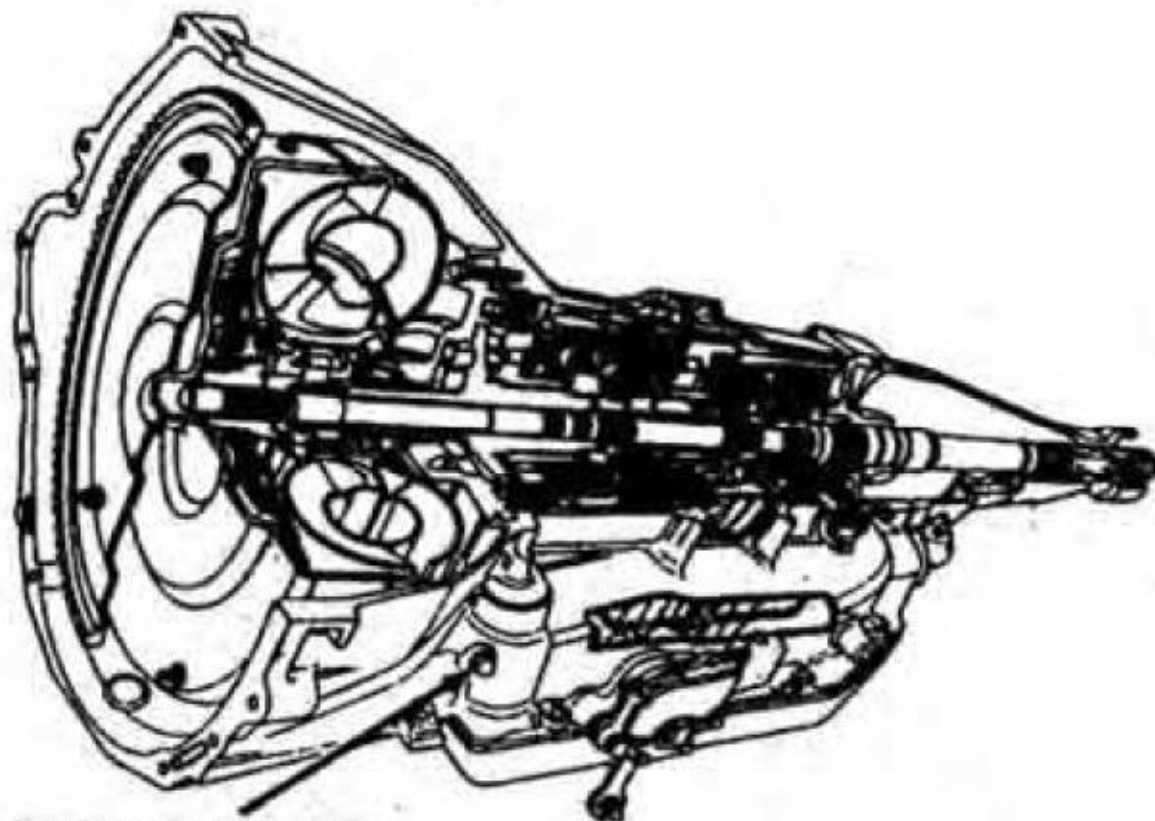

LINE PRESSURE TAP

D12119-A

2. Start engine and check line pressures. Refer to Other Concern: Pressure Reference Chart 401 under Diagnosis by Symptom Routines to determine if line pressure is within specification.

**CAUTION:** Perform line pressure test prior to performing stall speed test. If line pressure is low at stall, do not perform stall speed test or further transmission damage will occur. **DO NOT MAINTAIN WOT** in any transmission range **FOR MORE THAN FIVE SECONDS.**

**CAUTION:** Transmission tester **MUST BE REMOVED** from the transmission and the vehicle harness **reinstalled** to verify these pressures. **Improper pressure readings may lead to improper parts replacement or internal damage.**

3. If line pressure is not within specification, check EPC pressure.
4. Connect pressure gauge to EPC pressure tap.

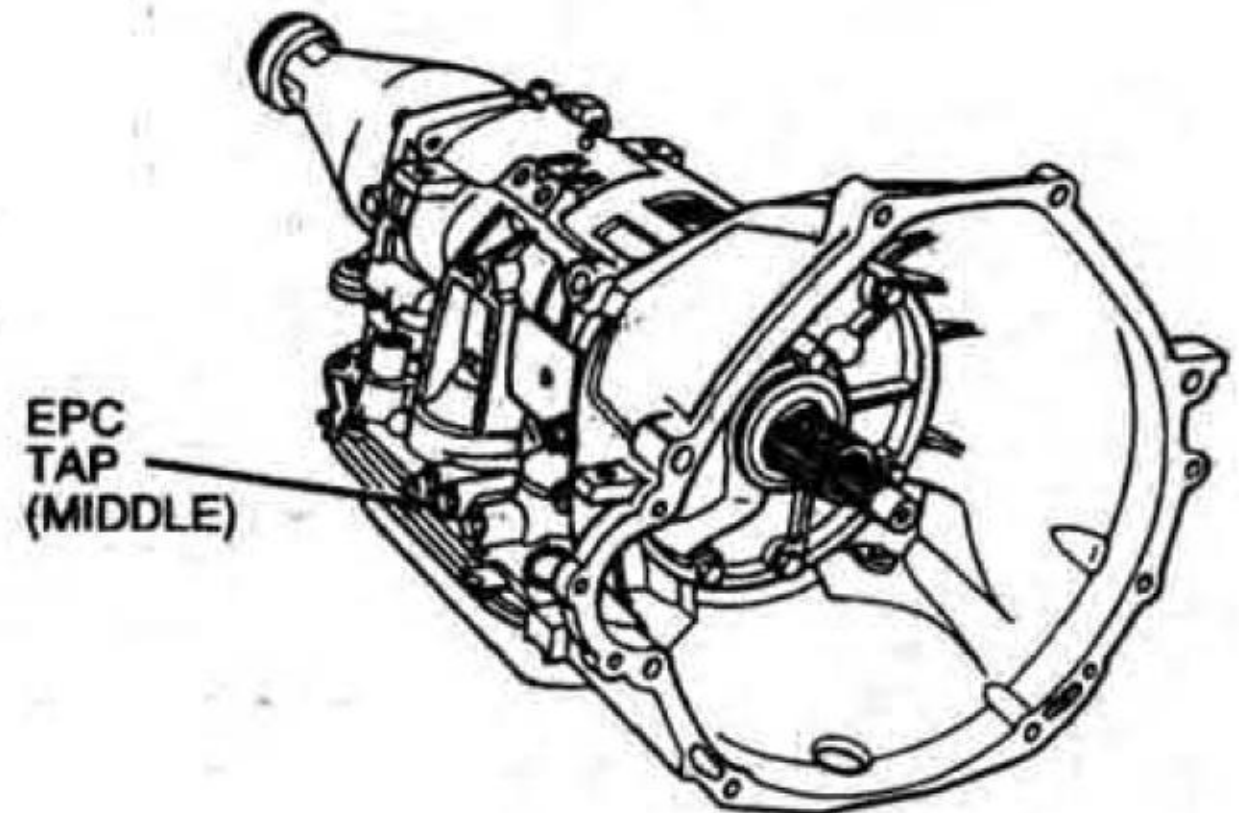

EPC TAP (MIDDLE)

D12120-A

5. Restart engine and check EPC pressure. Refer to Other Concern: Pressure Reference Chart 401.

<sup>11</sup> Can be purchased as a separate item.

## DIAGNOSIS AND TESTING (Continued)

## REFERENCE: PRESSURE CHART # 401

Application	Range	Idle		WOT Stall	
		EPC	Line Pressure	EPC	Line Pressure
4.6L Thunderbird, Cougar	P, N, OD, 2, 1 R	7-17 PSI	43-81 PSI	83-93 PSI	160-210 PSI
		7-17 PSI	68-112 PSI	83-93 PSI	207-267 PSI
3.8L Thunderbird, Cougar	P, N, OD, 2, 1 R	15-25 PSI	55-94 PSI	83-93 PSI	160-210 PSI
		3-13 PSI	60-104 PSI	83-93 PSI	207-267 PSI

6. If EPC pressure is not within specification, perform Pinpoint Test E to diagnose EPC operation. If EPC operation is OK, refer to Line Pressure Test Chart for line pressure concern causes.

## Line Pressure Test Chart

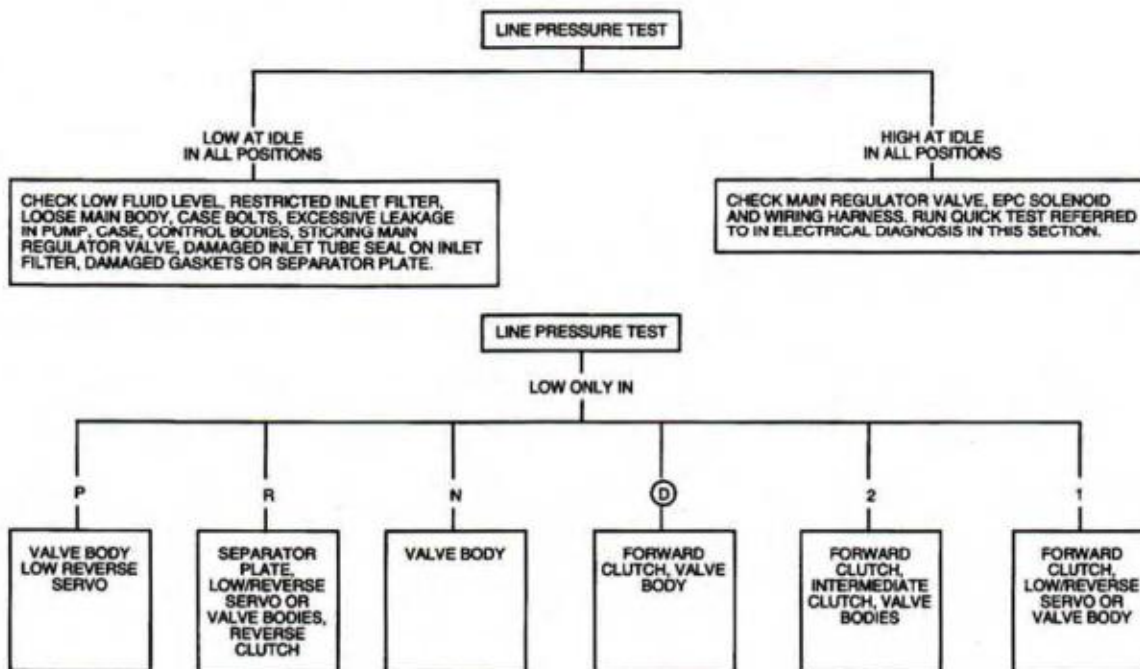

D12728-A

## Stall Speed Test

The stall speed test checks torque converter clutch operation and installation, the holding ability of the forward clutch, reverse clutch (the low-reverse bands), the planetary one-way clutch, and engine performance.

Conduct this test with the engine coolant and transmission fluid at proper levels and at normal operating temperature.

Apply the service and parking brake control (2780) firmly for each stall speed test.

- Find the specified stall rpm for the vehicle by referring to Specifications. Use a grease pencil to mark the rpm on the dial of a tachometer.

## STALL SPEED

Engine	rpm
3.8L	1880-2210
4.6L	2012-2375

- Connect tachometer to engine.

## DIAGNOSIS AND TESTING (Continued)

3. **NOTE:** If the rpm recorded by the tachometer exceeds the maximum limits given in Specifications, release the accelerator pedal immediately because clutch or band slippage is indicated.  
In each of the following ranges:  $\odot$ , 2, 1, R, press the accelerator pedal to the floor and hold it just long enough to let the engine get to wide open-throttle. While making this test, do not hold the throttle open for more than five seconds at a time.
4. Note the results in each range.
5. After each range, move the selector lever to NEUTRAL and run the engine at 1000 rpm for about 15 seconds to cool the torque converter (7902) before making the next test.
6. Refer to the following chart for corrective actions.

### STALL SPEED OUT OF SPECIFICATION DIAGNOSIS

Selector Position	Stall Speeds High	Stall Speeds Low
$\odot$	Planetary One-Way Clutch	
$\odot$ , 2 and 1	Forward Clutch or Intermediate Clutch	
$\odot$ , 2, 1 and R	Perform Pressure Test	Torque Converter Stator One-Way Clutch or Engine Performance
R	Reverse Clutch or Low Reverse Band or Servo	

### Air Pressure Tests

#### SPECIAL SERVICE TOOL(S) REQUIRED

Description	Tool Number
Transmission Test Plate	T92P-7006-A

A NO DRIVE condition can exist, even with correct transmission fluid pressure, because of inoperative clutches or bands. An ERRATIC SHIFT can be located through a series of checks by substituting air pressure for fluid pressure to determine the location of the malfunction.

Follow the procedure to determine the location of the inoperative clutch or band by introducing air pressure into the various test plate passages.

**NOTE:** Use only dried, regulated (276 kPa [40 psi] maximum) air pressure with Rubber-Tipped Air Gun D93L-7000-A or equivalent. Apply air to the appropriate passage(s). A dull thud should be heard when the clutch or band applies. There should be no hissing sound when the clutch or band is fully applied.

Cover the vent hole in the test plate with a clean, lint-free shop towel to prevent spray when the air is applied. Plugging the vent hole during testing will result in inaccurate results.

### Test Procedures

1. Drain transmission fluid and remove the transmission fluid pan.
2. Remove the main control and gasket.
3. Install AOD-E Transmission Test Plate T92P-7006-A and Replacement Gasket T92P-7006-A1. Tighten bolts to 10-12 N·m (89-106 lb-in).
4. **NOTE:** Do not apply air to the test plate vent hole. Apply air to the appropriate clutch port (refer to diagram).

A dull thud may be heard or movement felt when the clutch is applied or released. If clutch seals or check balls are leaking a hissing sound may be heard.

### Reverse Clutch

A dull thud can be heard when the reverse clutch piston (7D402) applies. In addition, movement of the reverse clutch drum (7D044) may also be detected.

### Forward Clutch Cylinder

A dull thud can be heard or movement of the clutch piston (7A262) can be felt on the case (7005) as the clutch piston is applied.

### Intermediate Clutch Cylinder

A dull thud can be heard or felt when the intermediate clutch piston (7E005) applies.

### Direct Clutch Cylinder

A dull thud should be heard or felt on the driveshaft if the clutch is operating.

### Overdrive Servo

Operation of the band is indicated by the tightening of the band around the reverse clutch drum. The O/D servo will return to the release position as a result of force from the overdrive servo piston return spring (7F201). Also, when the servo returns to the release position, a thud can be felt on the O/D servo retaining ring. The band will then relax.

### Low-Reverse Servo

A dull thud can be heard when the low-reverse band tightens around the planetary assembly drum surface. Also, movement of the ring gear can be detected.

### 2-3 Accumulator

The accumulator piston (7F251) should unseat. This can be detected by inserting a metal rod into the 2-3 piston hole. When the accumulator piston unseats, the rod will move. Also, a thud can be heard when the accumulator piston applies.

## DIAGNOSIS AND TESTING (Continued)

## Transmission Test Plate

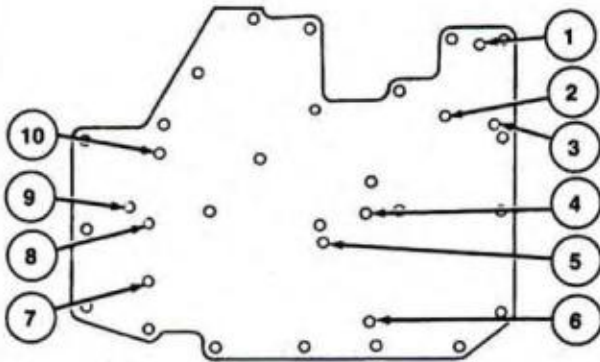

D10447-A

Item	Description
1	Converter Bypass
2	1-2 Accumulator Apply
3	Intermediate Clutch
4	Overdrive Servo Release
5	Reverse Servo
6	Overdrive Servo Apply
7	2-3 Accumulator Bottom
8	2-3 Accumulator Top
9	Forward Clutch
10	Direct Clutch

**Air Pressure Test Results**

If the servos do not operate, disassemble, clean and inspect them to locate the source of the concern.

If air pressure applied to the clutch passages fails to operate a clutch, or operates clutches simultaneously, inspect the fluid passages in the case.

If air pressure applied to the accumulator fails to operate an accumulator, remove and inspect case passages and piston.

**Direct Clutch Pressure Test**

The direct clutch pressure test will diagnose a low-pressure condition or leakage in the direct clutch circuit. A difference of 103 kPa (15 psi) or more between direct clutch pressure and line pressure (read at the forward clutch pressure tap) will prevent a normal 3-4 shift.

- CAUTION: Pressure gauges affect the shift quality of the transmission. Care should be taken not to accelerate or decelerate rapidly. Possible transmission failure could result.**

Attach 0-2000 kPa (0-300 psi) pressure gauges to the forward clutch pressure tap and to the direct clutch pressure tap. Gauges must be accurate enough to distinguish a 103 kPa (15 psi) difference. (If this test is done in conjunction with a line pressure test, pressure gauges will be attached to all pressure taps.) Have sufficient flexible hose to read the gauges in the vehicle.

- Drive the vehicle. When pressure is applied to the direct clutch, note the difference between the pressure read at forward clutch pressure tap and the direct clutch pressure.
- If the difference in pressures is less than 103 kPa (15 psi), the direct clutch circuit is OK.
- If the difference is greater than 103 kPa (15 psi), there could be a leak in the direct clutch pressure circuit. If the difference does not exceed 103 kPa (15 psi), the gauges on the line pressure and direct clutch pressure can be switched to confirm that gauge calibration difference is not the cause.

**Shift Linkage Check**

This is a **CRITICAL** adjustment. Be sure the  $\odot$  detent in the transmission corresponds exactly with the stop in the steering column tube (3514). Hydraulic leakage at the manual control valve can cause delay in engagements and / or slipping while operating if the linkage is not correctly adjusted.

NOTE: Check for a misadjustment in shift linkage. Do this by matching the detents in the transmission range selector lever with those in the transmission. If they match, the misadjustment is in the indicator. Do not adjust the shift linkage.

**Leakage Inspection**

Check the vehicle speed sensor (VSS)(9E731), output shaft speed sensor (OSS) and the connector at transmission. Replace the rubber seal, if necessary.

NOTE: Fluid from other external sources can collect between the case (7005) and pan rail to give the appearance of a pan-to-case gasket leak. If fluid is present check the following positions as described.

Check for leakage at pan-to-case gasket.

Leakage at the pan-to-case gasket often can be stopped by tightening the retaining bolts to 12-15 N-m (106-132 lb-in). Do not over-tighten transmission pan bolts. If necessary, replace the pan-to-case gasket.

If leakage is found at the wiring connector bulkhead assembly, replace the O-ring. Refer to Disassembly / Assembly for procedures.

**DIAGNOSIS AND TESTING (Continued)**

Check the fluid filler tube connection at the transmission case or transmission pan. If leakage is found here, install a new O-ring and press the fluid filler tube to the case. The fluid filler tube bracket should align properly and be attached to the transmission or engine.

Check the fluid tubes and fittings between the transmission and the transmission radiator in tank cooler for looseness, wear or damage. When fluid is found to be leaking at the cooler tube nuts, tighten the cooler tube nuts to 22-26 N·m (15-19 lb-ft). If the leak continues replace the cooler tube(s) or cooler tube nuts and tighten to 22-26 N·m (15-19 lb-ft).

**CAUTION: Do not try to stop the fluid leak by increasing the torque beyond specification. This may cause damage to the case threads.**

The same procedure should be followed for leaks between the case and cooler tube to case connector nut. Tighten this nut to 24-31 N·m (18-22 lb-ft). If leak continues, replace the cooler tube nut to case connector and tighten to 24-31 N·m (18-22 lb-ft).

Check the engine coolant in the radiator (8005). If transmission fluid is present in the coolant, the transmission cooler in the radiator is probably leaking.

The transmission cooler can be further checked for leaks by disconnecting the cooler tube and cooler inlet tube from the cooler fittings and applying 345-517 kPa (50-75 psi) air pressure to the fittings. Remove the radiator cap (8100) to relieve the pressure buildup at the exterior of the cooler tank. If the transmission cooler is leaking and / or will not hold pressure, the transmission cooler must be replaced. Refer to Section 07-02 for transmission cooler replacement procedure.

If leakage is found at the manual control lever (7A256), replace the manual control lever seal.

The transmission has five pipe plugs: four on the RH side of the case and one on the LH side. Inspect the plugs for leakage. Make sure they are tightened to 8-16 N·m (7-14 lb-in). If tightening of the pipe plugs does not stop the leak, replace the plug.

When a converter drain plug leaks, remove the drain plug with a six-point wrench. Coat the threads with Pipe Sealant with Teflon® D8AZ-19554-A or equivalent meeting Ford specification WSK-M2G350-A2 and install plug. Tighten the drain plug to 28-30 N·m (21-22 lb-ft). Fluid leakage from the converter housing may also be caused by engine oil leaking past the rear main bearing seal, or from oil galley plugs. Verify the exact cause of the leak before starting service procedures.

**External Sealing**

The 4R70W transmission has the following parts to prevent external fluid leakages:

**Seals and Gaskets**

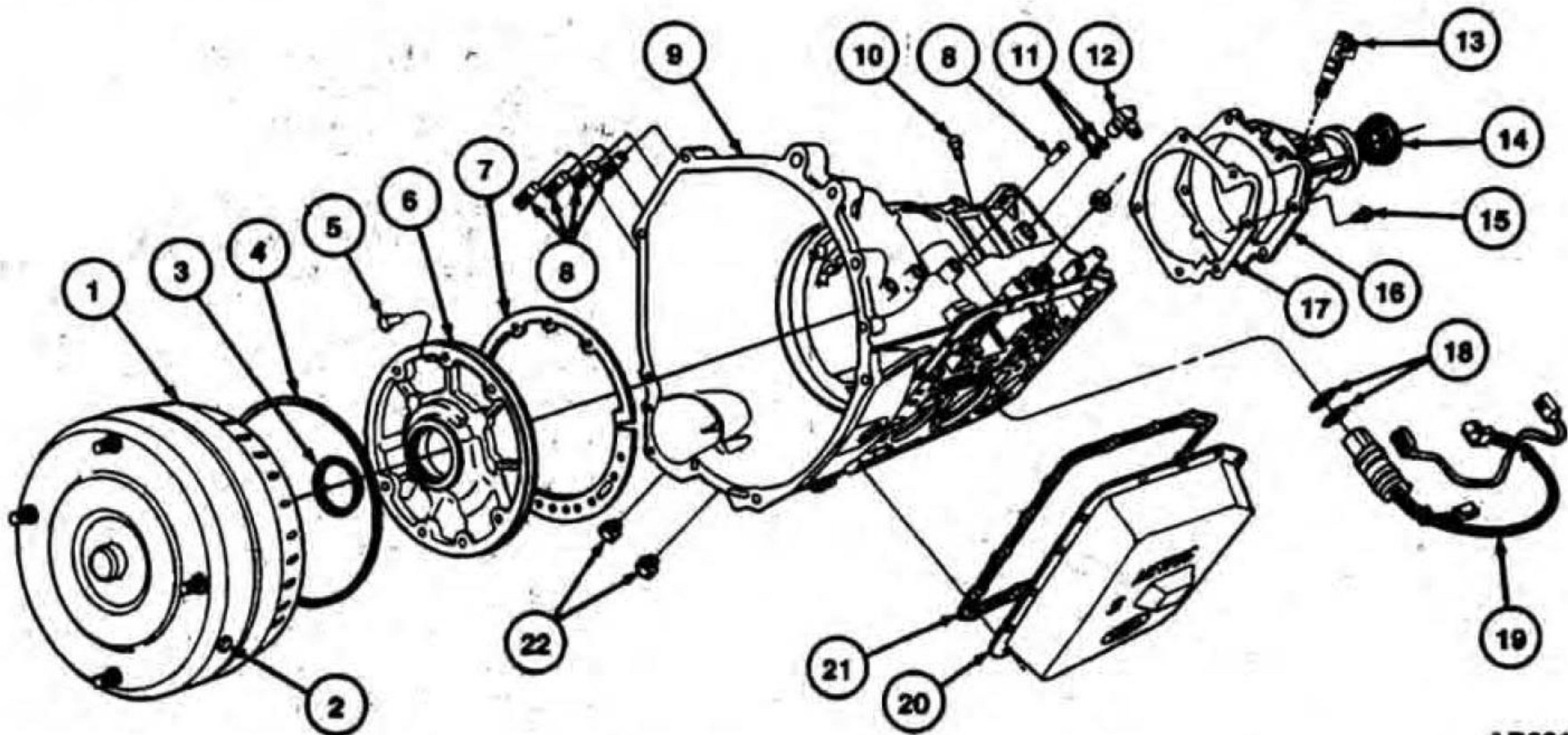

AD0317-A

Item	Part Number	Description
1	7902	Converter Assy
2	87650-S2	Plug-Converter Drain-1/8-27 Dry Seal (Part of 7902)

(Continued)

Item	Part Number	Description
3	7A248	Seal Assy - Front Pump
4	7A248	Seal Assy - Front Pump
5	N605789-S100	Bolt

(Continued)

## DIAGNOSIS AND TESTING (Continued)

Item	Part Number	Description
6	7A106	Body Assy - Front Pump
7	7A136	Gasket - Front Pump
8	390318-S100	Pipe Plug - 1/8-27 Dry Seal Tapered (5 Req'd)
9	7005	Case Assy
10	7034	Vent Assy - Case
11	7Z101	Seal - 14.0 X 1.78 O-Ring (2 Req'd)
12	7H103	Sensor Assy - Trans Output Shaft Speed
13	9E731	Vehicle Speed Sensor
14	7052	Seal Assy - Extension Housing

(Continued)

Item	Part Number	Description
15	N803747-S1000	Bolt - M8-1.25 X 30 (6 Req'd)
16	7A039	Extension Assy
17	7086	Gasket - Extension
18	391139-S	Seal - 0.864 X 0.070 O-Ring (2 Req'd)
19	7G276	Bulkhead Assy - Wiring Connector
20	7A194	Pan - Transmission
21	7A191	Gasket - Transmission Pan (Reuseable)
22	7D273	Connector Assy - Fluid Tube (2 Req'd)

**Fluid Leakage in Torque Converter Area**

In diagnosing and correcting fluid leaks in the front pump support and gear and torque converter area, use the following procedures to locate the exact cause of the leakage. Leakage at the front of transmission, as evidenced by fluid around the torque converter housing, may have several sources. By careful observation, it is possible, in many instances, to pinpoint the source of leak before removing the transmission from the vehicle. The paths which the fluid takes to reach the bottom of the torque converter housing are shown in the following illustration.

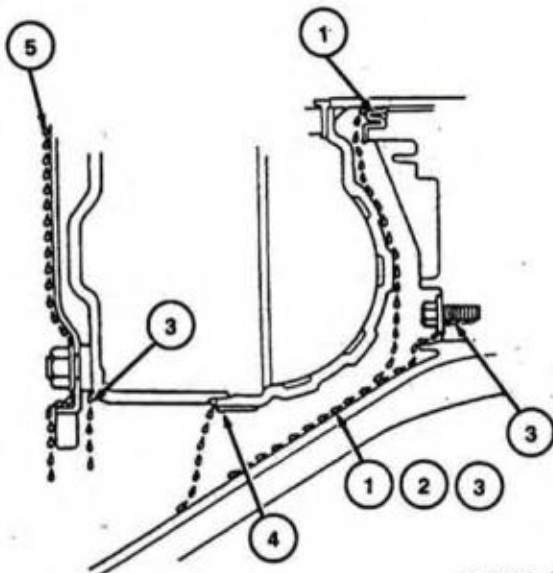

AD0318-A

1. Fluid leaking by the pump lip seal will tend to move along the impeller hub and onto the back of the impeller housing. Except in the case of a total seal failure, fluid leakage by the lip of the pump seal will wet the back of the torque converter (7902) and be deposited on the torque converter housing only, near the pump body.
2. Fluid leakage by the outside diameter seal of the pump body will be deposited only on the pump body and torque converter housing. Fluid will not be deposited on the back of the torque converter.
3. Fluid that leaks by the pump gasket and front pump-to-case bolt will be deposited on the inside of the torque converter housing only. Fluid will not be deposited on the back of the torque converter.
4. Fluid leakage from the converter drain plugs or converter-to-flywheel stud weld will appear at the outside diameter of the torque converter on the back face of the flywheel (6375), and in the converter housing only near the flywheel. Fluid leaks from the torque converter will leave a ring of fluid around the inside of the torque converter housing.
5. NOTE: A clean lint-free cloth may aid in determining the color (transmission fluid is red) and source of the leaking fluid.  
Engine oil leaks are sometimes improperly diagnosed as transmission pump gasket leaks. The following areas of possible leakage should also be checked to determine if engine oil leakage is causing the concern.
  - a. Leakage at the valve cover gasket (6584) may allow oil to flow over the torque converter housing or seep down between the torque converter housing and cylinder blocks (6010) causing oil to be present in or at the bottom of the torque converter housing.

**DIAGNOSIS AND TESTING (Continued)**

- b. Oil galley plug leaks will allow oil to flow down the rear face of the cylinder blocks to the bottom of the torque converter housing.
- c. Leakage at the crankshaft rear oil seal (6701) will work back to the flywheel, and then into the torque converter housing.
- d. Leakage at oil pressure sensor (9278).

**Leak Check Test**

Fluid leakage from other areas, such as the power steering system forward of the transmission, could cause fluid to be present around the torque converter housing due to blowback or road draft. The following procedures should be used to determine the cause of the leakage before service.

1. Remove the fluid level indicator and note the color of the fluid. Original factory fill fluid is dyed red to aid in determining if leakage is from the engine or transmission. However, a power steering leak may be mistaken for a transmission leak since both fluids are dyed red. Check the power steering system for leaks that could be misidentified as a transmission leak. Refer to Section 11-00.
2. Remove the torque converter housing cover. Clean off any fluid from the top and bottom of the torque converter housing, front of the case and rear face of the engine and oil pan (6675). Clean the torque converter area by washing with a suitable non-flammable solvent and blow dry with compressed air.
3. Wash out the torque converter housing, the front of the flywheel and the converter drain plugs. The torque converter housing may be washed out using cleaning solvent and a squirt-type oil can. Blow all washed areas dry with compressed air.
4. Start and run the engine until the transmission reaches its normal operating temperature. Observe the back of the cylinder blocks and top of the torque converter housing for evidence of fluid leakage. Raise the vehicle on a hoist and run the engine at fast idle, then at engine idle, occasionally shifting to the OVERDRIVE and REVERSE ranges to increase pressure within the transmission. Observe the front of the flywheel, back of the cylinder blocks (in as far as possible), and inside the torque converter housing and front of the automatic transmission/transaxle (A/T)(7000). Run the engine until fluid leakage is evident and the probable source of leakage can be determined.

**Leak Check Test with Black Light**

Oil soluble aniline or fluorescent dyes premixed at the rate of 2.5ml (1/2-teaspoon) of dye powder to 0.23 liter (1/2-pint) of transmission fluid have proved helpful in locating the source of fluid leakage. Such dyes may be used to determine whether an engine oil or transmission fluid leak is present, or if the fluid in the oil cooler leaks into the engine coolant system. A black light must be used with the fluorescent dye solution.

**Transmission Fluid Cooler**

**CAUTION:** Whenever a transmission has been disassembled to replace worn or damaged parts or because the main control valve body (7A100) sticks from foreign material, the main control valve body, transmission cooler and cooler inlet tube and cooler tube **MUST** be cleaned and flushed by using the Rotunda Torque Converter Cleaner 014-00028 or equivalent. Under **NO** circumstances should an attempt be made to clean torque converter (7902) by hand agitation with solvent. Damage to torque converter may result.

When internal wear or damage has occurred in the transmission, metal particles, clutch plate material, or band material may have been carried into the torque converter and transmission cooler. These contaminants are a major cause of recurring transmission troubles and **MUST** be removed from the system before the transmission is put back into service.

**Transmission Fluid Cooler Flow Test**

**NOTE:** The transmission linkage adjustment, fluid level and tube pressure must be within specification before performing this test. Refer to Section 07-05.

1. Remove fluid level indicator from fluid filler tube.
2. Place a funnel in filler tube.
3. Raise vehicle on a hoist and position suitable safety stands under vehicle. Refer to Section 00-02.
4. Remove cooler return tube (rear fitting) from fitting on transmission case (7005).
5. Connect one end of a hose to the cooler return tube and route other end of hose up to a point where it can be inserted into a funnel at the fluid filler tube.
6. Remove safety stands and lower vehicle. Insert end of hose into funnel.
7. Start engine and run at idle with transmission in neutral position.
8. When fluid flowing from hose is all liquid, an adequate amount of fluid should be observed (approximately 1 liter (1 quart) delivered in 30 seconds). If adequate flow is observed, test is complete.
9. If flow is not adequate, stop engine. Disconnect hose from cooler return tube and connect it to torque converter - out tube (front fitting) on case.
10. Repeat Steps 7 and 8. If flow is now approximately 1 liter (1 quart) in 30 seconds, perform Transmission Fluid Cooler - Backflushing / Cleaning as described; refer to Section 03-03 for diagnosis of transmission fluid cooler. If flow is still not approximately 1 liter (1 quart) in 30 seconds, service the pump and/or torque converter.

## DIAGNOSIS AND TESTING (Continued)

### Transmission Fluid Cooler—Backflushing/Cleaning

1. Perform backflushing with a Rotunda Torque Converter Cleaner 014-00028 or equivalent. Test the equipment to make sure that a vigorous fluid flow is present before proceeding. Replace the system filter if flow is weak or contaminated.
2. To aid in attaching the cleaner to the transmission steel cooler tubes, connect two additional rubber hoses to the transmission end of the steel transmission cooler lines as described below.
  - Connect the cleaner tank pressure line to the steel transmission cooler return tube (longer tube).
  - Connect a tank return hose to the steel transmission cooler pressure tube (shorter tube). Place the outlet end of this hose in the solvent tank reservoir.
3. Turn on solvent pump and allow the solvent to circulate a minimum of five minutes (cycling switch on and off will help dislodge contaminants in cooler system).

4. Switch off the solvent pump and disconnect the solvent pressure hose from the transmission cooler return tube.
5. Use compressed air to blow out the cooler(s) and tube (blow air into the transmission cooler return tube) until all solvent is removed.
6. Remove the rubber return hose from the remaining steel cooler tube.

### Transmission Fluid Cooler Tube Replacement

When fluid leakage is found at the transmission fluid cooler (7A095), the transmission fluid cooler must be replaced.

When one or more of the fluid cooler inlet tube (7A030) and fluid cooler tube (7A031) must be replaced, each replacement tube must be fabricated from the same size steel tubing as the original line.

Using the old tube as a guide, bend the new tube as required. Add the necessary fittings and install the tube.

After the fittings have been tightened, add fluid as necessary and check for fluid leaks.

### Diagnosis By Symptom Routines

The diagnosis by symptom charts give the service technician diagnostic information, direction and possible components, using a symptom as a starting point.

The diagnosis by symptom charts are divided into two categories: Electrical Routines, indicated by 200 series numbers, and Hydraulic/Mechanical Routines, indicated by 300 series numbers. The electrical routines list the possible electrical components that could cause or contribute to the symptom described. The hydraulic/mechanical routines list the possible hydraulic or mechanical components that could cause or contribute to the symptom described.

### Diagnosis By Symptom Charts—Directions

1. Using the index, select the concern/symptom that best describes the condition.
2. Turn to the routine indicated in the Diagnosis by Symptom Index.
3. Always begin diagnosis of a symptom by using the following:
  - a. preliminary inspections

- b. verification of condition
  - c. check the fluid level
  - d. perform other test procedures as directed
4. Then begin with the electrical routine, if indicated. Follow the reference or action required statements. Always perform the on-board diagnostic tests as required. **NEVER SKIP STEPS.** Service as required. If the concern is still present after electrical diagnosis, then proceed to the hydraulic/mechanical routine listed.
  5. NOTE: Not all concerns and conditions with electrical components will set a diagnostic trouble code (DTC). Be aware that the components listed may still be the cause. Verify proper function of those components prior to proceeding to the hydraulic/mechanical routine listed.

The hydraulic/mechanical routines list possible hydraulic or mechanical components that could cause the concern. These components are listed in the removal sequence and by most likely cause. You must inspect all components listed to ensure proper service.

### DIAGNOSIS BY SYMPTOM INDEX

Title	Routines	
	Electrical (1)	Hydraulic/Mechanical
<b>Engagement Concerns</b>		
No Forward	201	301
No Reverse	202	302
Harsh Reverse	203	303
Harsh Forward	204	304
Delayed/Soft Reverse	205	305

(Continued)

## DIAGNOSIS AND TESTING (Continued)

DIAGNOSIS BY SYMPTOM INDEX (Cont'd)		
Title	Routines	
	Electrical (1)	Hydraulic/Mechanical
Delayed / Soft Forward	206	306
<b>Shift Concerns</b>		
Some / All Shifts Missing	210	310
Timing Concerns		
—Early / Late	211	311
—Erratic / Hunting	212	312
Feel		
—Soft / Slipping	213	313
—Harsh	214	314
No 1st Gear, Engages in Higher Gear	215	315
No Manual 1st Gear	216	316
No Manual 2nd Gear	217	317
<b>Torque Converter Operation Concerns</b>		
No Apply	240	340
Always Applied / Stalls Vehicle	241	341
Cycling / Shudder / Chatter	242	342
<b>Other Concerns</b>		
No Engine Braking in 2nd Gear, Manual 2nd or Manual 1st Position	250	350
Shift Lever Efforts High	251	351
External Leaks	252	352
Poor Vehicle Performance	253	353
Noise / Vibration—Forward or Reverse	254	354
Engine Will Not Crank	255	355
No PARK Range	256	356
Overheating	257	357
<b>Reference: Pressure Reference Chart</b>		401
<b>Reference: Clutch and Band Application Chart</b>		601
<b>Reference: Solenoid Application Chart</b>		701

(1) Perform electrical routine first.

## Diagnostic Routines

## NO FORWARD ENGAGEMENT

Possible Component	Reference / Action
<b>201 — ELECTRICAL ROUTINE</b>	
● No Electrical Concerns	
<b>301 — HYDRAULIC / MECHANICAL ROUTINE</b>	
<b>Fluid</b>	
● Improper level	● Adjust fluid to proper level.
● Condition	● Inspect as described under Fluid Condition Check.
<b>Shift Linkage</b>	
● Damaged, out of adjustment	● Inspect and service as required. Verify linkage adjustment as described in Section 07-05. After servicing linkage, verify TR sensor is properly adjusted. Refer to Transmission, Assembly.
<b>Improper Pressures</b>	
● Low forward clutch pressure, low line pressure	● Check pressure at line and forward clutch tap. Refer to Other Concern: Pressure Reference Chart 401 for specification. If pressures are low, check the following possible components: — fluid filter and seal assembly, — main controls, pump assembly, — forward clutch assembly.

(Continued)

## DIAGNOSIS AND TESTING (Continued)

## NO FORWARD ENGAGEMENT (Cont'd)

Possible Component	Reference / Action
<b>Fluid Filter and Seal Assembly</b> <ul style="list-style-type: none"> <li>● Plugged, damaged</li> <li>● Filter seal damaged</li> </ul>	<ul style="list-style-type: none"> <li>● Replace fluid filter and seal assembly.</li> </ul>
<b>Main Controls</b> <ul style="list-style-type: none"> <li>● 3-4 shift valve, main regulator valve, manual valve stuck, damaged</li> <li>● Bolts out of torque specification</li> <li>● Gaskets damaged</li> <li>● 2-3 accumulator and seals damaged</li> </ul>	<ul style="list-style-type: none"> <li>● Inspect for damage. Service as required.</li> <li>● Tighten bolts to specification.</li> <li>● Inspect gasket for damage and replace.</li> <li>● Inspect piston, seals and bore for damage. Service as required.</li> </ul>
<b>Pump Assembly</b> <ul style="list-style-type: none"> <li>● Bolts out of torque specification</li> <li>● Porosity / cross leaks and ball missing or leaking, plugged hole</li> <li>● No. 3 and No. 4 seal rings damaged</li> <li>● Gaskets damaged</li> </ul>	<ul style="list-style-type: none"> <li>● Tighten bolts to specification.</li> <li>● Inspect for porosity and leaks. Service as required.</li> <li>● Inspect seals for damage. Service as required.</li> <li>● Inspect for damage and replace.</li> </ul>
<b>Forward Clutch Assembly</b> <ul style="list-style-type: none"> <li>● Seals, piston damaged</li> <li>● Check balls damaged, missing, mislocated, not seating properly</li> <li>● Friction elements damaged or worn</li> </ul>	<ul style="list-style-type: none"> <li>● Inspect seals for damage. Service as required.</li> <li>● Inspect for mislocation, poor seating, damage. Replace cylinder as required.</li> <li>● Check for abnormal wear, damage. Service as required.</li> </ul>
<b>Low One-Way Clutch Assembly (Planetary)</b> <ul style="list-style-type: none"> <li>● Worn, damaged or misassembled</li> </ul>	<ul style="list-style-type: none"> <li>● Inspect for damage. Service as required.</li> </ul>
<b>Output Shaft</b> <ul style="list-style-type: none"> <li>● Damaged</li> </ul>	<ul style="list-style-type: none"> <li>● Inspect for damage. Service as required.</li> </ul>

TD 10377G

## NO REVERSE ENGAGEMENT CONCERN:

Possible Component	Reference / Action
<b>202 — ELECTRICAL ROUTINE</b> <ul style="list-style-type: none"> <li>● No Electrical Concerns</li> </ul>	
<b>302 — HYDRAULIC / MECHANICAL ROUTINE</b>	
<b>Fluid</b> <ul style="list-style-type: none"> <li>● Improper level</li> <li>● Condition</li> </ul>	<ul style="list-style-type: none"> <li>● Adjust fluid to proper level.</li> <li>● Inspect as described under Fluid Condition Check.</li> </ul>
<b>Shift Linkage</b> <ul style="list-style-type: none"> <li>● Damaged or out of adjustment</li> </ul>	<ul style="list-style-type: none"> <li>● Inspect and service as required. Verify linkage adjustment as described in Section 07-05. After servicing linkage, verify that the TR sensor is properly adjusted. Refer to Transmission, Assembly.</li> </ul>
<b>Improper Pressures</b> <ul style="list-style-type: none"> <li>● Low reverse clutch pressure, low reverse band pressure, low line pressure</li> </ul>	<ul style="list-style-type: none"> <li>● Check pressure at line pressure tap. Refer to Other Concern: Pressure Reference Chart 401 for specifications. If pressures are low, check the following possible components: <ul style="list-style-type: none"> <li>— fluid filter and seal assembly,</li> <li>— main controls,</li> <li>— reverse servo,</li> <li>— pump assembly,</li> <li>— reverse clutch assembly.</li> </ul> </li> </ul>
<b>Fluid Filter and Seal Assembly</b> <ul style="list-style-type: none"> <li>● Plugged, damaged</li> </ul>	<ul style="list-style-type: none"> <li>● Replace filter and seal assembly.</li> </ul>
<b>Main Controls</b> <ul style="list-style-type: none"> <li>● No. 6 shuttle ball, manual valve, main regulator valve, 1-2 accumulator seals stuck or damaged</li> <li>● Bolts out of torque specification</li> <li>● Gasket damaged</li> </ul>	<ul style="list-style-type: none"> <li>● Inspect for damage. Service as required.</li> <li>● Tighten bolts to specification.</li> <li>● Inspect for damage and replace.</li> </ul>

(Continued)

## DIAGNOSIS AND TESTING (Continued)

## NO REVERSE ENGAGEMENT CONCERN: (Cont'd)

Possible Component	Reference / Action
<b>Low Reverse Servo</b> <ul style="list-style-type: none"> <li>● Seals (piston and cover) damaged</li> <li>● Servo cover retaining ring damaged</li> <li>● Anchor pins (case) damaged</li> </ul>	<ul style="list-style-type: none"> <li>● Inspect for damage. Service as required.</li> </ul>
<b>Pump Assembly</b> <ul style="list-style-type: none"> <li>● Bolts out of torque specification</li> <li>● Porosity / cross leaks / ball missing or leaking, plugged hole</li> <li>● Gasket damaged</li> <li>● No. 1 and 2 seal rings damaged</li> </ul>	<ul style="list-style-type: none"> <li>● Tighten bolts to specification.</li> <li>● Inspect pump assembly. Replace as required.</li> <li>● Inspect for damage and replace.</li> <li>● Inspect for damage. Service as required.</li> </ul>
<b>Reverse Clutch Assembly</b> <ul style="list-style-type: none"> <li>● Seals, piston damaged</li> <li>● Check ball missing or damaged</li> <li>● Friction elements damaged or worn</li> </ul>	<ul style="list-style-type: none"> <li>● Inspect for damage. Service as required.</li> </ul>
<b>Low Reverse Band</b> <ul style="list-style-type: none"> <li>● Band, servo, anchor pins damaged or worn</li> </ul>	<ul style="list-style-type: none"> <li>● Inspect for damage. Service as required.</li> </ul>

TD10379G

## ENGAGEMENT CONCERN: HARSH REVERSE

Possible Component	Reference / Action
<b>203 — ELECTRICAL ROUTINE</b>	
<b>Powertrain Control System</b> <ul style="list-style-type: none"> <li>● Electrical inputs / outputs, vehicle wiring harnesses, PCM, TP, MAF, EI system. EPC solenoid, TFT sensor</li> </ul>	<ul style="list-style-type: none"> <li>● Run Self-Test. Refer to Powertrain Control / Emissions Diagnosis Manual<sup>12</sup> for diagnosis. Perform engagement test. EPC test and Pinpoint Tests B and E using Rotunda Transmission Tester 007-00130 and Rotunda AODE / 4R70W Cable and Overlay 007-00122 or equivalent, as described. Service as required. Clear codes, road test and rerun self-test.</li> </ul>
<b>303 — HYDRAULIC / MECHANICAL ROUTINE</b>	
<b>Fluid</b> <ul style="list-style-type: none"> <li>● Improper level</li> <li>● Condition</li> </ul>	<ul style="list-style-type: none"> <li>● Adjust fluid to proper level.</li> <li>● Inspect as described under Fluid Condition Check.</li> </ul>
<b>Shift Linkage</b> <ul style="list-style-type: none"> <li>● Damaged or out of adjustment</li> </ul>	<ul style="list-style-type: none"> <li>● Inspect and service as required. Verify linkage adjustment as described in Section 07-05. After servicing linkage, verify that the TR sensor is properly adjusted. Refer to Transmission, Assembly.</li> </ul>
<b>Improper Pressures</b> <ul style="list-style-type: none"> <li>● High line pressure, high EPC pressure</li> </ul>	<ul style="list-style-type: none"> <li>● Check pressure at line and EPC pressure taps. Refer to Other Concern: Pressure Reference Chart 401 for specifications. If high, check the following possible components: main controls, oil filter and seal assembly.</li> </ul>
<b>Oil Filter and Seal Assembly</b> <ul style="list-style-type: none"> <li>● Plugged or damaged</li> <li>● Filter seal damaged</li> </ul>	<ul style="list-style-type: none"> <li>● Replace filter and seal assembly.</li> </ul>
<b>Main Controls</b> <ul style="list-style-type: none"> <li>● No. 6 Shuttle ball, No. 5 check ball, manual valve, main regulator valve stuck, damaged or missing</li> <li>● Loose bolts</li> <li>● Gasket damaged</li> <li>● EPC solenoid stuck or damaged</li> </ul>	<ul style="list-style-type: none"> <li>● Inspect for damage. Service as required.</li> <li>● Tighten bolts to specification.</li> <li>● Inspect for damage and replace.</li> <li>● Inspect for damage, contamination. Perform EPC test in Routine No. 203. Service as required.</li> </ul>
<b>Low Reverse Servo</b> <ul style="list-style-type: none"> <li>● Seals (piston and cover) damaged</li> <li>● Servo cover retaining ring damaged</li> <li>● Anchor pins (case) damaged</li> </ul>	<ul style="list-style-type: none"> <li>● Inspect for damage. Service as required.</li> </ul>

(Continued)

12 Can be purchased as a separate item.

## DIAGNOSIS AND TESTING (Continued)

## ENGAGEMENT CONCERN: HARSH REVERSE (Cont'd)

Possible Component	Reference / Action
<b>Pump Assembly</b> <ul style="list-style-type: none"> <li>● Loose bolts</li> <li>● Porosity / cross leaks</li> <li>● Gasket damaged</li> <li>● No. 1 and No. 2 seal rings damaged</li> </ul>	<ul style="list-style-type: none"> <li>● Tighten bolts to specification.</li> <li>● Inspect pump assembly. Replace as required.</li> <li>● Inspect for damage and replace.</li> <li>● Inspect for damage. Service as required.</li> </ul>
<b>Reverse Clutch Assembly</b> <ul style="list-style-type: none"> <li>● Seals, piston damaged</li> <li>● Check ball missing or damaged</li> <li>● Friction elements damaged, worn</li> <li>● Return spring piston damaged, worn</li> </ul>	<ul style="list-style-type: none"> <li>● Inspect for damage. Service as required.</li> </ul>
<b>Low Reverse Band</b> <ul style="list-style-type: none"> <li>● Band, servo, anchor pin damaged or worn</li> </ul>	<ul style="list-style-type: none"> <li>● Inspect for damage. Service as required.</li> </ul>

TD10381G

## HARSH FORWARD ENGAGEMENT

Possible Component	Reference / Action
<b>204 — ELECTRICAL ROUTINE</b>	
<b>Powertrain Control System</b> <ul style="list-style-type: none"> <li>● Electrical inputs / outputs, vehicle wiring harnesses, PCM, TFT sensor, EPC solenoid</li> </ul>	<ul style="list-style-type: none"> <li>● Run Self-Test. Refer to Powertrain Control / Emissions Diagnosis Manual<sup>13</sup> for diagnosis. Perform engagement test, EPC test and Pinpoint Tests B and E using Rotunda Transmission Tester 007-00130 and Rotunda AODE / 4R70W Cable and Overlay 007-00122 or equivalent, as described. Service as required. Clear codes, road test and rerun self-test.</li> </ul>
<b>304 — HYDRAULIC / MECHANICAL ROUTINE</b>	
<b>Fluid</b> <ul style="list-style-type: none"> <li>● Improper level</li> <li>● Condition</li> </ul>	<ul style="list-style-type: none"> <li>● Adjust fluid to proper level.</li> <li>● Inspect as described under Fluid Condition Check.</li> </ul>
<b>Improper Pressures</b> <ul style="list-style-type: none"> <li>● High forward clutch pressure, high line pressure, high EPC pressure</li> </ul>	<ul style="list-style-type: none"> <li>● Check pressure at line, EPC and forward pressure taps. Refer to Other Concern: Pressure Reference Chart 401 for specifications. If pressures are high, check the following possible components: main controls, pump assembly.</li> </ul>
<b>Main Controls</b> <ul style="list-style-type: none"> <li>● Main regulator valve, 2-3 backout valve, 2-3 accumulator seal / retainer stuck, damaged</li> <li>● Bolts out of torque specification</li> <li>● Gaskets damaged</li> <li>● EPC solenoid stuck or damaged</li> </ul>	<ul style="list-style-type: none"> <li>● Inspect and service as required.</li> <li>● Tighten bolts to specification.</li> <li>● Inspect for damage and replace.</li> <li>● Inspect for damage or contamination. Perform EPC test in Routine No. 204. Service as required.</li> </ul>
<b>Pump Assembly</b> <ul style="list-style-type: none"> <li>● Bolts out of torque specification</li> <li>● Porosity / cross leaks</li> <li>● Gaskets damaged</li> <li>● No. 3 and No. 4 seal ring damage</li> </ul>	<ul style="list-style-type: none"> <li>● Tighten bolts to specification.</li> <li>● Inspect for porosity / leaks. Replace pump assembly as required.</li> <li>● Inspect for damage and replace.</li> </ul>
<b>Forward Clutch Assembly</b> <ul style="list-style-type: none"> <li>● Check balls missing or damaged</li> <li>● Friction element damaged or worn</li> <li>● Forward clutch wave spring damaged</li> <li>● Forward clutch return spring damaged</li> </ul>	<ul style="list-style-type: none"> <li>● Inspect for mislocation, poor seating, damage. Replace forward clutch cylinder.</li> <li>● Inspect for damage. Service as required.</li> <li>● Inspect for damage. Service as required.</li> <li>● Inspect for damage. Service as required.</li> </ul>

TD10383H

13 Can be purchased as a separate item.

## DIAGNOSIS AND TESTING (Continued)

## DELAYED / SOFT REVERSE ENGAGEMENT

Possible Component	Reference / Action
<b>205 — ELECTRICAL ROUTINE</b>	
● No Electrical Concerns	
<b>305 — HYDRAULIC / MECHANICAL ROUTINE</b>	
<b>Fluid</b>	
● Improper level	● Adjust fluid to proper level.
● Condition	● Inspect as described under Fluid Condition Check.
<b>Shift Linkage</b>	
● Damaged, out of adjustment	● Inspect and service as required. Verify linkage adjustment as described in Section 07-05. After servicing linkage, verify that the TR sensor is properly adjusted. Refer to Transmission, Assembly.
<b>Improper Pressures</b>	
● Low reverse clutch pressure, low reverse band pressure, low line pressure	● Check pressure at line tap. Refer to Other Concern: Pressure Reference Chart 401 for specifications. If pressures are low, check the following possible components: main controls, pump assembly, reverse clutch assembly, reverse servo.
<b>Fluid Filter and Seal Assembly</b>	
● Plugged, damaged	● Replace fluid filter and seal assembly.
● Fluid filter seal damaged	
<b>Main Controls</b>	
● No. 6 shuttle ball, 1-2 accumulator seals, manual valve, main regulator valve stuck or damaged	● Inspect for damage. Service as required.
● Bolts out of torque specification	● Tighten bolts to specification.
● Gaskets damaged	● Inspect for damage and replace.
<b>Low Reverse Servo</b>	
● Seals (piston and cover) damaged	● Inspect for damage. Service as required.
● Servo cover retaining ring assembled wrong.	
<b>Pump Assembly</b>	
● Bolts out of torque specification	● Tighten bolts to specification.
● Porosity / cross leaks / ball missing or leaking	● Inspect pump assembly. Replace as required.
● Gaskets damaged	● Inspect for damage and replace.
● No. 1 and No. 2 seal rings damaged	● Inspect for damage. Service as required.
<b>Reverse Clutch Assembly</b>	
● Seals, piston damaged	● Inspect for damage. Service as required.
● Check ball missing or damaged	
● Friction elements damaged, worn	
● Return spring and piston damaged, worn	
<b>Low Reverse Band</b>	
● Damaged, worn	● Inspect for damage. Service as required.

TD 10385G

## DELAYED / SOFT FORWARD ENGAGEMENT

Possible Component	Reference / Action
<b>206 — ELECTRICAL ROUTINE</b>	
● No Electrical Concerns	
<b>306 — HYDRAULIC / MECHANICAL ROUTINE</b>	
<b>Fluid</b>	
● Improper level	● Adjust fluid to proper level.
● Condition	● Inspect as described under Fluid Condition Check.
<b>Shift Linkage</b>	
● Damaged, out of adjustment	● Inspect and service as required. Verify linkage adjustment as described in Section 07-05. After servicing linkage, verify that the TR sensor is properly adjusted. Refer to Transmission, Assembly.

(Continued)

## DIAGNOSIS AND TESTING (Continued)

## DELAYED / SOFT FORWARD ENGAGEMENT (Cont'd)

Possible Component	Reference / Action
<b>Improper Pressures</b> <ul style="list-style-type: none"> <li>● Low forward clutch pressure, low line pressure, low EPC pressure</li> </ul>	<ul style="list-style-type: none"> <li>● Check pressure at line, forward clutch and EPC taps. Refer to Other Concern: Pressure Reference Chart 401 for specifications. If pressures are low, check the following possible components: fluid filter and seal assembly, main controls and pump assembly.</li> </ul>
<b>Fluid Filter and Seal Assembly</b> <ul style="list-style-type: none"> <li>● Plugged, damaged</li> <li>● Fluid filter seal damaged</li> </ul>	<ul style="list-style-type: none"> <li>● Replace fluid filter and seal assembly.</li> </ul>
<b>Main Controls</b> <ul style="list-style-type: none"> <li>● 3-4 shift valve, main regulator valve</li> <li>● Bolts out of torque specification</li> <li>● Gaskets damaged</li> <li>● 2-3 or 1-2 accumulator, seals, bore damaged or stuck</li> </ul>	<ul style="list-style-type: none"> <li>● Inspect and service as required.</li> <li>● Tighten bolts to specification.</li> <li>● Inspect for damage and replace.</li> <li>● Inspect for damage. Service as required.</li> </ul>
<b>Pump Assembly</b> <ul style="list-style-type: none"> <li>● Bolts out of torque specification</li> <li>● Porosity / cross leaks</li> <li>● Gaskets damaged</li> <li>● No. 3, No. 4 seal rings damaged</li> </ul>	<ul style="list-style-type: none"> <li>● Tighten bolts to specification.</li> <li>● Inspect pump assembly. Replace as required.</li> <li>● Inspect for damage and replace.</li> <li>● Inspect for damage. Service as required.</li> </ul>
<b>Forward Clutch Assembly</b> <ul style="list-style-type: none"> <li>● Seals, piston damaged</li> <li>● Check balls missing, damaged</li> <li>● Friction elements damaged, worn</li> </ul>	<ul style="list-style-type: none"> <li>● Inspect for damage. Service as required.</li> <li>● Inspect for mislocation, poor seating, damage. Replace cylinder as required.</li> <li>● Check for damage. Service as required.</li> </ul>

TD10411F

## SHIFT CONCERNS: SOME OR ALL SHIFTS MISSING

Possible Component	Reference / Action
<b>210 — ELECTRICAL ROUTINE</b>	
<b>Powertrain Control System</b> <ul style="list-style-type: none"> <li>● Electrical inputs / outputs, vehicle wiring harnesses, powertrain control module, shift solenoids, output shaft speed (OSS) sensor, TR sensor</li> </ul>	<ul style="list-style-type: none"> <li>● Run self-test. Refer to Powertrain Control/Emissions Diagnosis Manual<sup>14</sup> for diagnosis. Perform Pinpoint Tests A, D and F using Rotunda Transmission Tester 007-00130 with Rotunda AODE/4R70W Cable and Overlay 007-00122 and Rotunda MLP-C Cable 007-00128 or equivalents, as described. Service as required. Clear codes, road test and rerun self-test.</li> </ul>
<b>310 — HYDRAULIC/MECHANICAL ROUTINE</b>	
<b>Fluid</b> <ul style="list-style-type: none"> <li>● Improper level</li> <li>● Condition</li> </ul>	<ul style="list-style-type: none"> <li>● Adjust fluid to proper level.</li> <li>● Inspect as described under Fluid Condition Check.</li> </ul>
<b>Shift Linkage, TR Sensor</b> <ul style="list-style-type: none"> <li>● Damaged, out of adjustment</li> </ul>	<ul style="list-style-type: none"> <li>● Inspect and service as required. Verify linkage adjustment as described in Section 07-05. After servicing linkage, verify that the TR sensor is properly adjusted. Refer to Transmission, Assembly.</li> <li>● Refer to the following shift routine(s) for further diagnosis:  <b>Shift 1-2, Routine 220/320</b>  <b>Shift 2-3, Routine 221/321</b>  <b>Shift 3-4, Routine 222/322</b>  <b>Shift 4-3, Routine 223/323</b>  <b>Shift 3-2, Routine 224/324</b>  <b>Shift 2-1, Routine 225/325</b> </li> </ul>

TD10387G

14 Can be purchased as a separate item.

## DIAGNOSIS AND TESTING (Continued)

## SHIFT CONCERNS: SHIFT TIMING — EARLY/LATE

Possible Component	Reference/Action
<b>211 — ELECTRICAL ROUTINE</b>	
<b>Powertrain Control System</b> <ul style="list-style-type: none"> <li>● Electrical inputs/outputs, vehicle wiring harnesses, powertrain control module, shift solenoids, EPC solenoid, TFT sensor, OSS</li> </ul>	<ul style="list-style-type: none"> <li>● Run self-test. Refer to Powertrain Control/Emissions Diagnosis Manual<sup>15</sup> for diagnosis. Perform Pinpoint Tests A, B, E and F using Rotunda Transmission Tester 007-00130 and Rotunda AODE/4R70W Cable and Overlay 007-00122 or equivalents, as described. Service as required. Clear codes, road test and rerun Self-Test.</li> </ul>
<b>311 — HYDRAULIC/MECHANICAL ROUTINE</b>	
<b>Other</b> <ul style="list-style-type: none"> <li>● Tire size change, axle ratio change</li> </ul>	<ul style="list-style-type: none"> <li>● Verify vehicle has original equipment. Refer to Certification Label and Safety Standard Certification Label. Changes in tire size, axle ratio will affect shift timing.</li> </ul>
<b>Fluid</b> <ul style="list-style-type: none"> <li>● Improper level</li> <li>● Condition</li> </ul>	<ul style="list-style-type: none"> <li>● Adjust fluid to proper level.</li> <li>● Inspect as described under Fluid Condition Check.</li> </ul>
<b>Improper Pressures</b> <ul style="list-style-type: none"> <li>● Line pressure, EPC pressure</li> </ul>	<ul style="list-style-type: none"> <li>● Check pressure at line and EPC taps. Refer to Other Concern: Pressure Reference Chart 401 for specifications. If not OK, check the main controls. If OK, refer to the following shift routine(s) for further diagnosis:  <b>Shift 1-2, Routine 320</b>  <b>Shift 2-3, Routine 321</b>  <b>Shift 3-4, Routine 322</b>  <b>Shift 4-3, Routine 323</b>  <b>Shift 3-2, Routine 324</b>  <b>Shift 2-1, Routine 325</b> </li> </ul>
<b>Main Controls</b> <ul style="list-style-type: none"> <li>● EPC solenoid, stuck or damaged hydraulically or mechanically</li> <li>● Valves, accumulators, seals stuck or damaged or misassembled</li> <li>● Gaskets damaged</li> <li>● Solenoid screen (in valve body) blocked or damaged</li> </ul>	<ul style="list-style-type: none"> <li>● Inspect for damage, contamination. Perform EPC tests in Routine No. 211. Service as required.</li> <li>● Inspect for damage. Service as required.</li> <li>● Inspect for damage and replace.</li> <li>● Clean or replace screen.</li> </ul>

TD10389G

## SHIFT CONCERNS: TIMING—ERRATIC/HUNTING

Possible Component	Reference/Action
<b>212 — ELECTRICAL ROUTINE</b>	
<b>Powertrain Control System</b> <ul style="list-style-type: none"> <li>● Electrical inputs/outputs, vehicle wiring harnesses, powertrain control module, shift solenoids, TCC solenoid, TR sensor, OSS</li> </ul>	<ul style="list-style-type: none"> <li>● Run self-test. Refer to Powertrain Control/Emissions Diagnosis Manual<sup>15</sup> for diagnosis. Perform Pinpoint Tests A, C, D and F using Rotunda Transmission Tester 007-00130 with Rotunda AODE/4R70W Cable and Overlay 007-00122 and Rotunda MLP-C Cable 007-00128 or equivalent, as described. Service as required. Clear codes, road test and rerun self-test.</li> </ul>
<b>312 — HYDRAULIC/MECHANICAL ROUTINE</b>	
<b>Fluid</b> <ul style="list-style-type: none"> <li>● Improper level</li> <li>● Condition</li> </ul>	<ul style="list-style-type: none"> <li>● Adjust fluid to proper level.</li> <li>● Inspect as described under Transmission Fluid Condition Check.</li> </ul>
<b>Main Controls</b> <ul style="list-style-type: none"> <li>● Valves, accumulators, seals, misassembled, stuck or damaged</li> <li>● Gaskets damaged</li> <li>● Solenoid screen (in valve body) blocked or damaged</li> </ul>	<ul style="list-style-type: none"> <li>● Inspect for damage. Service as required.</li> <li>● Inspect for damage and replace.</li> <li>● Clean or replace screen.</li> </ul>
<b>Torque Converter Clutch</b> <ul style="list-style-type: none"> <li>● Torque converter</li> </ul>	<ul style="list-style-type: none"> <li>● Refer to Hydraulic/Mechanical Routine 342, Converter Cycling/Shudder/Chatter.</li> </ul>

(Continued)

15 Can be purchased as a separate item.

## DIAGNOSIS AND TESTING (Continued)

## SHIFT CONCERNS: TIMING—ERRATIC/HUNTING (Cont'd)

Possible Component	Reference/Action
Specific Shifts	<ul style="list-style-type: none"> <li>Refer to the following shift routine(s) for further diagnosis:               <ul style="list-style-type: none"> <li>Shift 1-2, Routine, 320</li> <li>Shift 2-3, Routine, 321</li> <li>Shift 3-4, Routine, 322</li> <li>Shift 4-3, Routine, 323</li> <li>Shift 3-2, Routine, 324</li> <li>Shift 2-1, Routine, 325</li> </ul> </li> </ul>

## SHIFT CONCERNS: FEEL — SOFT/SLIPPING

Possible Component	Reference/Action
<b>213 — ELECTRICAL ROUTINE</b>	
<b>Powertrain Control System</b> <ul style="list-style-type: none"> <li>Electrical inputs/outputs, vehicle wiring harnesses, powertrain control module, EPC solenoid, OSS</li> </ul>	<ul style="list-style-type: none"> <li>Run Self-Test. Refer to Powertrain Control/Emissions Diagnosis Manual<sup>16</sup> for diagnosis. Perform Pinpoint Tests E and F using Rotunda Transmission Tester 007-00130 and Rotunda AODE/4R70W Cable and Overlay 007-00122 or equivalent, as described. Service as required. Clear codes, road test and rerun Self-Test.</li> </ul>
<b>313 — HYDRAULIC/MECHANICAL ROUTINE</b>	
<b>Fluid</b> <ul style="list-style-type: none"> <li>Improper level</li> <li>Condition</li> </ul>	<ul style="list-style-type: none"> <li>Adjust fluid to proper level.</li> <li>Inspect as described under Fluid Condition Check.</li> </ul>
<b>Improper Pressures</b> <ul style="list-style-type: none"> <li>Low line pressure, low EPC pressure</li> </ul>	<ul style="list-style-type: none"> <li>Check pressures at line and EPC taps. Refer to Other Concern: Pressure Reference Chart 401 for specifications. If pressures are low or all shifts are soft/slipping, go to Main Controls. If pressures are OK and a specific shift is soft/slipping, refer to the following routine(s) for further diagnosis:               <ul style="list-style-type: none"> <li>Shift 1-2, Routine, 320</li> <li>Shift 2-3, Routine, 321</li> <li>Shift 3-4, Routine, 322</li> <li>Shift 4-3, Routine, 323</li> <li>Shift 3-2, Routine, 324</li> <li>Shift 2-1, Routine, 325</li> </ul> </li> </ul>
<b>Main Controls</b> <ul style="list-style-type: none"> <li>1-2 accumulator, 2-3 backout valve, main regulator valve, overdrive servo regulator valve stuck, damaged or misassembled</li> <li>EPC solenoid stuck or damaged</li> </ul>	<ul style="list-style-type: none"> <li>Inspect for damage. Service as required.</li> <li>Inspect for damage and contamination. Perform EPC tests in Routine No. 213. Service as required.</li> </ul>

TD10393J

## SHIFT CONCERNS: FEEL — HARSH

Possible Component	Reference/Action
<b>214 — ELECTRICAL ROUTINE</b>	
<b>Powertrain Control System</b> <ul style="list-style-type: none"> <li>Electrical inputs/outputs, vehicle wiring harnesses, EPC solenoid, OSS</li> </ul>	<ul style="list-style-type: none"> <li>Run self-test. Refer to Powertrain Control/Emissions Diagnosis Manual<sup>16</sup> for diagnosis. Perform Pinpoint Tests E and F using Rotunda Transmission Tester 007-00130 and Rotunda AODE/4R70W Cable and Overlay 007-00122 or equivalent, as described. Service as required. Clear codes, road test and rerun Self-Test.</li> </ul>
<b>314 — HYDRAULIC/MECHANICAL ROUTINE</b>	
<b>Fluid</b> <ul style="list-style-type: none"> <li>Improper level</li> <li>Condition</li> </ul>	<ul style="list-style-type: none"> <li>Adjust fluid to proper level.</li> <li>Inspect as described under Fluid Condition Check.</li> </ul>

(Continued)

<sup>16</sup> Can be purchased as a separate item.

## DIAGNOSIS AND TESTING (Continued)

## SHIFT CONCERNS: FEEL — HARSH (Cont'd)

Possible Component	Reference/Action
<b>Improper Pressures</b> <ul style="list-style-type: none"> <li>High line pressure, high EPC pressure</li> </ul>	<ul style="list-style-type: none"> <li>Check pressures at line and EPC taps. Refer to Other Concern: Pressure Reference Chart 401 for specifications. If pressures are high or all shifts are harsh, go to Main Controls. If pressures are OK and a specific shift is harsh, refer to the following shift routine(s) for further diagnosis: <ul style="list-style-type: none"> <li>Shift 1-2, Routine, 320</li> <li>Shift 2-3, Routine, 321</li> <li>Shift 3-4, Routine, 322</li> <li>Shift 4-3, Routine, 323</li> <li>Shift 3-2, Routine, 324</li> <li>Shift 2-1, Routine, 325</li> </ul> </li> </ul>
<b>Main Controls</b> <ul style="list-style-type: none"> <li>1-2 accumulator, 2-3 backout valve, main regulator valve, overdrive servo regulator valve stuck, damaged or misassembled</li> <li>EPC solenoid stuck or damaged</li> </ul>	<ul style="list-style-type: none"> <li>Inspect for damage. Service as required.</li> <li>Inspect for damage, contamination. Perform EPC tests in Routine 214. Service as required.</li> </ul>

TD 10395J

## SHIFT CONCERNS: NO 1ST GEAR, ENGAGES IN HIGHER GEAR

Possible Component	Reference/Action
<b>215 — ELECTRICAL ROUTINE</b>	
<b>Powertrain Control System</b> <ul style="list-style-type: none"> <li>Electrical inputs/outputs, vehicle wiring harnesses, powertrain control module, shift solenoids, TR sensor</li> </ul>	<ul style="list-style-type: none"> <li>Run Self-Test. Refer to Powertrain Control/Emissions Diagnosis Manual<sup>17</sup> for diagnosis. Perform Pinpoint Tests A and D using Rotunda Transmission Tester 007-00130 with Rotunda AODE/4R70W Cable and Overlay 007-00122 and Rotunda MLP-C Cable 007-00128 or equivalent, as described. Service as required. Clear codes, road test and rerun Self-Test.</li> </ul>
<b>315 — HYDRAULIC/MECHANICAL ROUTINE</b>	
<b>Shift Linkage, TR Sensor</b> <ul style="list-style-type: none"> <li>Damaged or out of adjustment</li> </ul>	<ul style="list-style-type: none"> <li>Inspect and service as required. Verify linkage adjustment as described in Section 07-05. After servicing linkage, verify that the TR sensor is properly adjusted. Refer to Transmission, Assembly.</li> </ul>
<b>Improper Pressures</b> <ul style="list-style-type: none"> <li>Low reverse clutch pressure, low reverse band pressure, low line pressure</li> <li>Forward Off, Intermediate Off, Direct X</li> <li>Forward Off, Intermediate X, Direct Off</li> <li>Forward Off, Intermediate X, Direct X</li> <li>Forward X, Intermediate Off, Direct X</li> <li>Forward X, Intermediate X, Direct Off</li> <li>Forward X, Intermediate X, Direct X</li> <li>Forward X, Intermediate Off, Direct Off</li> </ul>	<ul style="list-style-type: none"> <li>Check for which pressures are on as follows and corresponding routines<sup>18</sup>: <ul style="list-style-type: none"> <li>324, 301</li> <li>325, 301</li> <li>323, 324, 325, 301</li> <li>324</li> <li>325</li> <li>323, 324, 325</li> </ul> </li> <li>Refer to appropriate Mechanical Diagnosis</li> </ul>
<b>Mechanical</b> <ul style="list-style-type: none"> <li>Bands, clutches or seals damaged or worn</li> </ul>	<ul style="list-style-type: none"> <li>Refer to Transmission, Disassembly and Assembly.</li> </ul>

17 Can be purchased as a separate item.

18 X = pressures applied.

## DIAGNOSIS AND TESTING (Continued)

## SHIFT CONCERNS: NO MANUAL 1ST GEAR

Possible Component	Reference/Action
<b>216 — ELECTRICAL ROUTINE</b>	
<b>Powertrain Control System</b> <ul style="list-style-type: none"> <li>● Electrical inputs / outputs, vehicle wiring harnesses, PCM, shift solenoids, TR sensor</li> </ul>	<ul style="list-style-type: none"> <li>● Run self-test. Refer to Powertrain Control/Emissions Diagnosis Manual<sup>19</sup> for diagnosis. Perform Pinpoint Tests A and D using Rotunda Transmission Tester 007-00130 with Rotunda AODE / 4R70W Cable and Overlay 007-00122 and Rotunda MLP-C Cable 007-00128 or equivalent, as described. Service as required. Clear codes, road test and rerun self-test.</li> </ul>
<b>316 — HYDRAULIC/MECHANICAL ROUTINE</b>	
<b>Shift Linkage, Cable, TR Sensor</b> <ul style="list-style-type: none"> <li>● Damaged or out of adjustment</li> </ul>	<ul style="list-style-type: none"> <li>● Inspect and service as required. Verify linkage adjustment as described in Section 07-05. After servicing linkage, verify that the TR sensor is properly adjusted. Refer to Transmission, Assembly.</li> </ul>
<b>Improper Pressures</b> <ul style="list-style-type: none"> <li>● Low reverse clutch pressure, low reverse band pressure, low line pressure, low EPC pressure</li> </ul>	<ul style="list-style-type: none"> <li>● Check pressure at line and EPC pressure taps. Refer to Other Concern: Pressure Reference Chart 401 for specifications. If pressures are low, check the following possible components: oil filter and seal assembly, main controls, reverse clutch assembly and reverse servo assembly.</li> </ul>
<b>Oil Filter and Seal Assembly</b> <ul style="list-style-type: none"> <li>● Plugged or damaged</li> </ul>	<ul style="list-style-type: none"> <li>● Replace filter and seal assembly.</li> </ul>
<b>Main Controls</b> <ul style="list-style-type: none"> <li>● No. 6 shuttle ball, manual valve, main regulator valve, low servo modulator valve stuck, damaged</li> <li>● Loose bolts</li> <li>● Gaskets damaged</li> </ul>	<ul style="list-style-type: none"> <li>● Inspect for damage. Service as required.</li> <li>● Tighten bolts to specification.</li> <li>● Inspect for damage and replace.</li> </ul>
<b>Low Reverse Servo</b> <ul style="list-style-type: none"> <li>● Seals (piston and cover) damaged</li> <li>● Servo cover retaining ring damaged</li> <li>● Anchor pins (case) damaged</li> </ul>	<ul style="list-style-type: none"> <li>● Inspect for damage. Service as required.</li> </ul>

TD10399J

## SHIFT CONCERNS: NO MANUAL 2ND GEAR

Possible Component	Reference/Action
<b>217 — ELECTRICAL ROUTINE</b>	
<b>Powertrain Control System</b> <ul style="list-style-type: none"> <li>● Electrical inputs / outputs, vehicle wiring harnesses, powertrain control module (PCM), shift solenoids, TR sensor</li> </ul>	<ul style="list-style-type: none"> <li>● Run Self-Test. Refer to Powertrain Control/Emissions Diagnosis Manual<sup>19</sup> for diagnosis. Perform Pinpoint Tests A and D using Rotunda Transmission Tester 007-00130 with Rotunda AODE / 4R70W Cable and Overlay 007-00122 and Rotunda MLP-C Cable 007-00128 or equivalent, as described. Service as required. Clear codes, road test and rerun self-test.</li> </ul>
<b>317 — HYDRAULIC/MECHANICAL ROUTINE</b>	
<b>Shift Linkage, Cable, TR Sensor</b> <ul style="list-style-type: none"> <li>● Damaged, out of adjustment</li> </ul>	<ul style="list-style-type: none"> <li>● Inspect and service as required. Verify linkage adjustment as described in Section 07-05. After servicing linkage, verify that the TR sensor is properly adjusted. Refer to Transmission Assembly procedures.</li> </ul>
<b>Main Controls</b> <ul style="list-style-type: none"> <li>● 3-4 shift valve, 1-2 and 2-3 shift valve, 3-4 capacity modulator valve stuck, damaged or misassembled</li> <li>● Bolts out of torque specification</li> <li>● Gaskets damaged</li> </ul>	<ul style="list-style-type: none"> <li>● Inspect for damage. Service as required.</li> <li>● Tighten bolts to specification.</li> <li>● Inspect for damage and replace.</li> </ul>

TD8098M

<sup>19</sup> Can be purchased as a separate item.

## DIAGNOSIS AND TESTING (Continued)

## SHIFT CONCERNS: 1-2 SHIFT (AUTOMATIC)

Possible Component	Reference/Action
<b>220 — ELECTRICAL ROUTINE</b>	
<b>Powertrain Control System</b> <ul style="list-style-type: none"> <li>● Electrical inputs/outputs, vehicle wiring harnesses, PCM, MAF, TP, VSS, OSS, TR sensor, shift solenoids, EI system</li> </ul>	<ul style="list-style-type: none"> <li>● Run self-test. Refer to Powertrain Control/Emissions Diagnosis Manual<sup>20</sup> for diagnosis. Perform Pinpoint Tests A, D and F using Rotunda Transmission Tester 007-00130 with Rotunda AODE/4R70W Cable and Overlay 007-00122 and Rotunda MLP-C Cable 007-00128 or equivalent, as described. Service as required. Clear codes, road test and rerun self-test.</li> </ul>
<b>320 — HYDRAULIC/MECHANICAL ROUTINE</b>	
<b>Shift Linkage, TR Sensor</b> <ul style="list-style-type: none"> <li>● Damaged or out of adjustment</li> </ul>	<ul style="list-style-type: none"> <li>● Inspect and service as required. Verify linkage adjustment as described in Section 07-05. After servicing linkage, verify that the TR sensor is properly adjusted. Refer to Transmission, Assembly.</li> </ul>
<b>Improper Pressures</b> <ul style="list-style-type: none"> <li>● Intermediate clutch pressure, line pressure</li> </ul>	<ul style="list-style-type: none"> <li>● Check pressure at line and intermediate clutch taps. Refer to Other Concern: Pressure Reference Chart 401 for specifications. If not OK, check the Main Controls.</li> </ul>
<b>Main Controls</b> <ul style="list-style-type: none"> <li>● 1-2 shift valve, 1-2 accumulator valve stuck or damaged</li> <li>● Loose bolts</li> <li>● SS1 malfunction</li> <li>● Gasket damaged</li> <li>● No. 8 ball not seating</li> </ul>	<ul style="list-style-type: none"> <li>● Inspect for damage. Service as required.</li> <li>● Tighten bolts to specification.</li> <li>● Activate solenoid using transmission tester. If solenoid operation cannot be felt when placing hand on solenoid, replace solenoid. Inspect O-rings for damage. Service as required.</li> <li>● Inspect for damage and replace.</li> <li>● Inspect for damage and service as required.</li> </ul>
<b>Pump</b> <ul style="list-style-type: none"> <li>● Porosity/cross leaks, balls missing, damaged or leaking</li> <li>● Gasket damaged</li> </ul>	<ul style="list-style-type: none"> <li>● Inspect for porosity/leaks, balls missing. Replace pump as required.</li> <li>● Inspect for damage and replace.</li> </ul>
<b>Intermediate Clutch Assembly</b> <ul style="list-style-type: none"> <li>● Seals damaged</li> <li>● Piston damaged</li> <li>● Friction elements damaged or worn</li> </ul>	<ul style="list-style-type: none"> <li>● Inspect for damage. Service as required.</li> <li>● Inspect for damage. Service as required.</li> <li>● Inspect for damage. Service as required.</li> </ul>
<b>Intermediate One-Way Clutch Assembly</b> <ul style="list-style-type: none"> <li>● Not holding or damaged</li> </ul>	<ul style="list-style-type: none"> <li>● Inspect for damage. Service as required.</li> </ul>
<b>Low One-Way Clutch Assembly</b> <ul style="list-style-type: none"> <li>● Not overrunning or damaged</li> </ul>	<ul style="list-style-type: none"> <li>● Inspect for damage. Service as required.</li> </ul>

TD10401K

## SHIFT CONCERNS: 2-3 SHIFT (AUTOMATIC)

Possible Component	Reference/Action
<b>221 — ELECTRICAL ROUTINE</b>	
<b>Powertrain Control System</b> <ul style="list-style-type: none"> <li>● Electrical inputs/outputs, vehicle wiring harnesses, PCM, TP, MAF, VSS, OSS, TR sensor, shift solenoids, EI system</li> </ul>	<ul style="list-style-type: none"> <li>● Run self-test. Refer to Powertrain Control/Emissions Diagnosis Manual<sup>20</sup> for diagnosis. Perform Pinpoint Tests A, D and F using Rotunda Transmission Tester 007-00130 with Rotunda AODE/4R70W Cable and Overlay 007-00122 and Rotunda MLP-C Cable 007-00128 or equivalent, as described. Service as required. Clear codes, road test and rerun self-test.</li> </ul>
<b>321 — HYDRAULIC/MECHANICAL ROUTINE</b>	
<b>Shift Linkage</b> <ul style="list-style-type: none"> <li>● Damaged or out of adjustment</li> </ul>	<ul style="list-style-type: none"> <li>● Inspect and service as required. Verify linkage adjustment as described in Section 07-05. After servicing linkage, verify that the TR sensor is properly adjusted. Refer to Transmission, Assembly.</li> </ul>

(Continued)

20 Can be purchased as a separate item.

## DIAGNOSIS AND TESTING (Continued)

## SHIFT CONCERNS: 2-3 SHIFT (AUTOMATIC) (Cont'd)

Possible Component	Reference / Action
<b>Improper Pressures</b> <ul style="list-style-type: none"> <li>● Direct clutch pressure</li> </ul>	<ul style="list-style-type: none"> <li>● Check pressure at direct clutch tap. Refer to Other Concern: Pressure Reference Chart 401 for specifications. If not OK, check the main controls.</li> </ul>
<b>Main Controls</b> <ul style="list-style-type: none"> <li>● 2-3 shift valve, check ball No. 3 or No. 9, solenoid pressure regulator valve, 2-3 backout valve, 2-3 modulator valve, damaged or misassembled</li> <li>● Loose bolts</li> <li>● SS2 malfunction</li> <li>● Gaskets damaged</li> <li>● Output shaft seals damaged or cup plug leaking or missing</li> <li>● 2-3 accumulator damaged or stuck</li> <li>● Solenoid screen (in main control) blocked or damaged</li> </ul>	<ul style="list-style-type: none"> <li>● Inspect for damage. Service as required.</li> <li>● Tighten bolts to specification.</li> <li>● Activate solenoid using transmission tester. If solenoid operation cannot be felt when placing hand on solenoid, replace solenoid. Inspect O-rings for damage. Service as required.</li> <li>● Inspect for damage and replace.</li> <li>● Inspect for damage and service as required.</li> <li>● Inspect piston seal and bore for damage. Service as required.</li> <li>● Clean or replace screen.</li> </ul>
<b>Intermediate One-Way Clutch Assembly</b> <ul style="list-style-type: none"> <li>● Not overrunning or damaged</li> </ul>	<ul style="list-style-type: none"> <li>● Inspect for damage. Service as required.</li> </ul>
<b>Output Shaft</b> <ul style="list-style-type: none"> <li>● Seal rings damaged</li> <li>● Cup plug damaged or missing</li> </ul>	<ul style="list-style-type: none"> <li>● Inspect for damage. Service as required.</li> </ul>
<b>Direct Clutch Assembly</b> <ul style="list-style-type: none"> <li>● Seals or piston damaged</li> <li>● Friction elements worn or damaged</li> <li>● Check ball not seating</li> <li>● Return spring assembly damaged</li> </ul>	<ul style="list-style-type: none"> <li>● Inspect for damage. Service as required.</li> <li>● Inspect for damage. Service as required.</li> <li>● Inspect for damage. Service as required.</li> <li>● Inspect for damage. Service as required.</li> </ul>
<b>Case</b> <ul style="list-style-type: none"> <li>● Output shaft rear seals leaking or damaged</li> </ul>	<ul style="list-style-type: none"> <li>● Inspect for damage. Service as required. Inspect case for damaged seal area. If damaged, replace case.</li> </ul>

TD 10403K

## SHIFT CONCERNS: 3-4 SHIFT (AUTOMATIC)

Possible Component	Reference / Action
<b>222 — ELECTRICAL ROUTINE</b>	
<b>Powertrain Control System</b> <ul style="list-style-type: none"> <li>● Electrical inputs / outputs, vehicle wiring harnesses, PCM, TP, MAF, VSS, OSS, TR sensor, TCS, shift solenoids, EI system</li> </ul>	<ul style="list-style-type: none"> <li>● Run self-test. Refer to Powertrain Control / Emissions Diagnosis Manual<sup>21</sup> for diagnosis. Perform Pinpoint Tests A, D and F using Rotunda Transmission Tester 007-00130 with Rotunda AODE / 4R70W Cable and Overlay 007-00122 and Rotunda MLP-C Cable 007-00128 or equivalent, as described. Service as required. Clear codes, road test and rerun self-test.</li> </ul>
<b>322 — HYDRAULIC / MECHANICAL ROUTINE</b>	
<b>Shift Linkage, TR Sensor</b> <ul style="list-style-type: none"> <li>● Damaged or out of adjustment</li> </ul>	<ul style="list-style-type: none"> <li>● Inspect and service as required. Verify linkage adjustment as described in Section 07-05. After servicing linkage, verify that the TR sensor is properly adjusted. Refer to Transmission, Assembly.</li> </ul>
<b>Improper Pressures</b> <ul style="list-style-type: none"> <li>● Forward clutch pressure, direct clutch pressure, line pressure</li> </ul>	<ul style="list-style-type: none"> <li>● Check line, direct and forward clutch pressures at appropriate taps. Refer to Other Concern: Pressure Reference Chart 401 for specifications. If pressures are out of specification, check main controls.</li> </ul>
<b>Main Controls</b> <ul style="list-style-type: none"> <li>● 3-4 shift valve, solenoid pressure regulator valve, OD servo regulator, 3-4 capacity modulator valve, 2-3 backout valve, 1-2 and 2-3 shift valves stuck, damaged</li> </ul>	<ul style="list-style-type: none"> <li>● Inspect for damaged and service as required.</li> </ul>

(Continued)

21 Can be purchased as a separate item.

## DIAGNOSIS AND TESTING (Continued)

## SHIFT CONCERNS: 3-4 SHIFT (AUTOMATIC) (Cont'd)

Possible Component	Reference/Action
<ul style="list-style-type: none"> <li>Loose bolts</li> <li>SS1 or SS2 malfunction</li> <li>Gaskets damaged</li> <li>OD servo cover, rod and piston cushion spring or seals damaged</li> <li>No's 2, 4, 7, and 9 check balls damaged or missing</li> <li>Solenoid screen (in main control) blocked or damaged</li> </ul>	<ul style="list-style-type: none"> <li>Tighten bolts to specification.</li> <li>Activate solenoid using transmission tester. If solenoid operation cannot be felt when placing hand on solenoid, replace solenoid. Inspect O-rings for damage. Service as required.</li> <li>Inspect for damage and replace.</li> <li>Inspect for damage. Service as required.</li> <li>Inspect for damage. Service as required.</li> <li>Clean or replace screen.</li> </ul>
<b>Pump</b> <ul style="list-style-type: none"> <li>Porosity/cross leaks, balls missing, damaged or leaking</li> <li>Gaskets damaged</li> </ul>	<ul style="list-style-type: none"> <li>Inspect for porosity/leaks, balls missing. Replace pump as required.</li> <li>Inspect for damage. Replace as required.</li> </ul>
<b>OD Band</b> <ul style="list-style-type: none"> <li>OD band and reverse clutch drum assembly damaged, worn</li> <li>Intermediate one-way clutch assembly damaged</li> </ul>	<ul style="list-style-type: none"> <li>Inspect for damage and service as required.</li> <li>Inspect for damage. Service as required.</li> </ul>
<b>Forward Clutch Assembly</b> <ul style="list-style-type: none"> <li>Seals or piston damaged</li> <li>Friction elements worn or damaged</li> <li>Check ball stuck, damaged or not seating properly</li> </ul>	<ul style="list-style-type: none"> <li>Inspect for damage. Service as required.</li> <li>Inspect for damage. Service as required.</li> <li>Inspect for damage. Service as required.</li> </ul>
<b>Input Shaft</b> <ul style="list-style-type: none"> <li>Seals damaged</li> </ul>	<ul style="list-style-type: none"> <li>Inspect for damage. Service as required.</li> </ul>

TD10405L

## SHIFT CONCERNS: 4-3 SHIFT (AUTOMATIC)

Possible Component	Reference/Action
<b>223 — ELECTRICAL ROUTINE</b>	
<b>Powertrain Control System</b> <ul style="list-style-type: none"> <li>Electrical inputs/outputs, vehicle wiring harnesses, PCM, TP, MAF, VSS, OSS, TR sensor, TCS, shift solenoids, EI system.</li> </ul>	<ul style="list-style-type: none"> <li>Run Self-Test. Refer to Powertrain Control/Emissions Diagnosis Manual<sup>22</sup> for diagnosis. Perform Pinpoint Tests A, D and F using Rotunda Transmission Tester 007-00130 with Rotunda AODE/4R70W Cable and Overlay 007-00122 and Rotunda MLP-C Cable 007-00128 or equivalent, as described. Service as required. Clear codes, road test and rerun self test.</li> </ul>
<b>323 — HYDRAULIC/MECHANICAL ROUTINE</b>	
<b>Improper Pressures</b> <ul style="list-style-type: none"> <li>Forward clutch pressure, line pressure</li> </ul>	<ul style="list-style-type: none"> <li>Check line and forward clutch at pressure taps. Refer to Other Concern: Pressure Reference Chart 401 for specifications. If out of specification, check main controls.</li> </ul>
<b>Main Controls</b> <ul style="list-style-type: none"> <li>3-4 shift valve, solenoid pressure regulator valve, OD servo regulator, 3-4 capacity modulator, 2-3 backout valve, 1-2, 2-3 shift valves stuck, damaged</li> <li>Check balls No. 2, No. 7, No. 9 damaged, missing or not seating properly</li> <li>Loose bolts</li> <li>SS1 malfunction</li> <li>Gaskets damaged</li> <li>OD servo, seal, rod damaged</li> <li>Solenoid screen (in main control) blocked or damaged</li> </ul>	<ul style="list-style-type: none"> <li>Inspect for damage. Service as required.</li> <li>Inspect for damage. Service as required.</li> <li>Tighten bolts to specification.</li> <li>Activate solenoid using transmission tester. If solenoid operation cannot be felt when placing hand on solenoid, replace solenoid. Inspect O-rings for damage. Service as required.</li> <li>Inspect for damage and replace.</li> <li>Inspect for damage. Service as required.</li> <li>Clean or replace screen.</li> </ul>
<b>Pump</b> <ul style="list-style-type: none"> <li>Porosity/cross leaks, balls missing, damaged or leaking</li> <li>Seal rings damaged.</li> <li>Gaskets damaged</li> </ul>	<ul style="list-style-type: none"> <li>Inspect for porosity/leaks, balls missing. Replace pump as required.</li> <li>Inspect for damage. Service as required.</li> <li>Inspect for damage and replace.</li> </ul>

(Continued)

22. Can be purchased as a separate item.

## DIAGNOSIS AND TESTING (Continued)

## SHIFT CONCERNS: 4-3 SHIFT (AUTOMATIC) (Cont'd)

Possible Component	Reference / Action
<b>Overdrive Band</b> <ul style="list-style-type: none"> <li>● OD band and reverse clutch assembly damaged, worn</li> <li>● Intermediate one-way clutch assembly damaged</li> </ul>	<ul style="list-style-type: none"> <li>● Inspect for damage. Service as required.</li> <li>● Inspect for damage. Service as required.</li> </ul>
<b>Forward Clutch Assembly</b> <ul style="list-style-type: none"> <li>● Seals or piston damaged</li> <li>● Friction elements damaged, worn</li> <li>● Check ball stuck, damaged or not seating properly</li> <li>● Forward clutch piston and return spring damaged</li> </ul>	<ul style="list-style-type: none"> <li>● Inspect for damage. Service as required.</li> <li>● Inspect for damage. Service as required.</li> <li>● Inspect for damage. Service as required.</li> <li>● Inspect for damage. Service as required.</li> </ul>
<b>Input Shaft</b> <ul style="list-style-type: none"> <li>● Seals damaged</li> </ul>	<ul style="list-style-type: none"> <li>● Inspect for damage. Service as required.</li> </ul>

TD 10407L

## SHIFT CONCERNS: 3-2 SHIFT (AUTOMATIC)

Possible Component	Reference / Action
<b>224 — ELECTRICAL ROUTINE</b>	
<b>Powertrain Control System</b> <ul style="list-style-type: none"> <li>● Electrical inputs / outputs, vehicle wiring harnesses, PCM, TP, MAF, VSS, OSS, TR sensor, shift solenoids, EI system.</li> </ul>	<ul style="list-style-type: none"> <li>● Run self-test. Refer to Powertrain Control / Emissions Diagnosis Manual<sup>23</sup> for diagnosis. Perform Pinpoint Tests A, D and F using Rotunda Transmission Tester 007-00130 with Rotunda AODE / 4R70W Cable and Overlay 007-00122 and Rotunda MLP-C Cable 007-00128 or equivalent, as described. Service as required. Clear codes, road test and rerun self test.</li> </ul>
<b>324 — HYDRAULIC / MECHANICAL ROUTINE</b>	
<b>Improper Pressures</b> <ul style="list-style-type: none"> <li>● Direct clutch</li> </ul>	<ul style="list-style-type: none"> <li>● Check pressure at direct clutch tap. Refer to Other Concern: Pressure Reference Chart 401 for specifications. If not within specification, check Main Controls.</li> </ul>
<b>Main Controls</b> <ul style="list-style-type: none"> <li>● 2-3 shift valve stuck or damaged</li> <li>● Check balls damaged or missing</li> <li>● Loose bolts</li> <li>● SS2 malfunction</li> </ul>	<ul style="list-style-type: none"> <li>● Inspect for damage. Service as required</li> <li>● Inspect for damage. Service as required.</li> <li>● Tighten bolts to specification.</li> <li>● Activate solenoid using transmission tester. If solenoid operation cannot be felt when placing hand on solenoid, replace solenoid. Inspect O-rings for damage. Service as required.</li> <li>● Inspect for damage and replace.</li> </ul>
<b>Intermediate One-Way Clutch</b> <ul style="list-style-type: none"> <li>● Not holding or damaged</li> </ul>	<ul style="list-style-type: none"> <li>● Inspect for damage. Service as required.</li> </ul>
<b>Direct Clutch Assembly</b> <ul style="list-style-type: none"> <li>● Seals or piston damaged</li> <li>● Friction element damaged, worn</li> <li>● Check ball stuck, damaged or not seating properly</li> </ul>	<ul style="list-style-type: none"> <li>● Inspect for damage. Service as required.</li> <li>● Inspect for damage. Service as required.</li> <li>● Inspect for damage. Service as required.</li> </ul>

TD 10409L

## SHIFT CONCERNS: 2-1 SHIFT (AUTOMATIC)

Possible Component	Reference / Action
<b>225 — ELECTRICAL ROUTINE</b>	
<b>Powertrain Control System</b> <ul style="list-style-type: none"> <li>● Electrical inputs / outputs, vehicle wiring harnesses, PCM, TP, MAF, VSS, OSS, TR sensor, shift solenoids, EI system.</li> </ul>	<ul style="list-style-type: none"> <li>● Run self-test. Refer to Powertrain Control / Emissions Diagnosis Manual<sup>23</sup> for diagnosis. Perform Pinpoint Tests A, D and F using Rotunda Transmission Tester 007-00130 with Rotunda AODE / 4R70W Cable and Overlay 007-00122 and Rotunda MLP-C Cable 007-00128 or equivalent, as described. Service as required. Clear codes, road test and rerun self test.</li> </ul>

(Continued)

23 Can be purchased as a separate item.

**DIAGNOSIS AND TESTING (Continued)**

**SHIFT CONCERNS: 2-1 SHIFT (AUTOMATIC) (Cont'd)**

Possible Component	Reference / Action
<b>325 — HYDRAULIC / MECHANICAL ROUTINE</b>	
<b>Improper Pressures</b> <ul style="list-style-type: none"> <li>● Intermediate clutch</li> </ul>	<ul style="list-style-type: none"> <li>● Check pressure at intermediate clutch tap. Refer to Other Concern: Pressure Reference Chart 401 for specifications. If not within specifications, check Main Controls and Pump.</li> </ul>
<b>Main Controls</b> <ul style="list-style-type: none"> <li>● 1-2 shift valve, 1-2 accumulator solenoid pressure regulator valve stuck, damaged</li> <li>● Loose bolts</li> <li>● SS1 malfunction</li> <li>● Gaskets damaged</li> </ul>	<ul style="list-style-type: none"> <li>● Inspect for damage. Service as required.</li> <li>● Tighten bolts to specification.</li> <li>● Activate solenoid using transmission tester. If solenoid operation cannot be felt when placing hand on solenoid, replace solenoid. Inspect O-rings for damage; service as required.</li> <li>● Inspect for damage and replace.</li> </ul>
<b>Pump</b> <ul style="list-style-type: none"> <li>● Gaskets damaged</li> <li>● Porosity / cross leaks</li> </ul>	<ul style="list-style-type: none"> <li>● Inspect for damage and replace.</li> <li>● Inspect for leak / porosity. Replace pump as required.</li> </ul>
<b>Intermediate Clutch Assembly</b> <ul style="list-style-type: none"> <li>● Piston damaged</li> <li>● Friction elements damaged, worn</li> <li>● End clearance improper</li> </ul>	<ul style="list-style-type: none"> <li>● Inspect for damage. Service as required.</li> <li>● Inspect for damage. Service as required.</li> <li>● Inspect and correct as described under Transmission, Assembly</li> </ul>
<b>Intermediate One-Way Clutch</b> <ul style="list-style-type: none"> <li>● Damaged</li> </ul>	<ul style="list-style-type: none"> <li>● Inspect for damage. Service as required.</li> </ul>
<b>Low One-Way Clutch</b> <ul style="list-style-type: none"> <li>● Not holding or damaged</li> </ul>	<ul style="list-style-type: none"> <li>● Inspect for damage. Service as required.</li> </ul>

TD10413K

**TORQUE CONVERTER OPERATION CONCERN: NO APPLY**

Possible Component	Reference / Action
<b>240 — ELECTRICAL ROUTINE</b>	
<b>Powertrain Control System</b> <ul style="list-style-type: none"> <li>● Electrical inputs / outputs, vehicle wiring harnesses, PCM, TP, MAF, VSS, OSS, TR sensor, TFT sensor, TCC solenoids, EI system.</li> </ul>	<ul style="list-style-type: none"> <li>● Run self-test. Refer to Powertrain Control / Emissions Diagnosis Manual<sup>24</sup> for diagnosis. Perform Pinpoint Tests B, C, D and F using Rotunda Transmission Tester 007-00130 with Rotunda AODE / 4R70W Cable and Overlay 007-00122 and Rotunda MLP-C Cable 007-00128 or equivalent, as described. Service as required. Clear codes, road test and rerun self test.</li> </ul>
<b>340 — HYDRAULIC / MECHANICAL ROUTINE</b>	
<b>Shift Linkage</b> <ul style="list-style-type: none"> <li>● Damaged, out of adjustment</li> </ul>	<ul style="list-style-type: none"> <li>● Inspect and service as required. Verify linkage adjustment as described in Section 07-05. After servicing linkage, verify that the TR sensor is properly adjusted. Refer to Transmission, Assembly.</li> </ul>
<b>Improper Pressures</b> <ul style="list-style-type: none"> <li>● Low line pressure, low EPC pressure</li> </ul>	<ul style="list-style-type: none"> <li>● Check pressure at line and EPC taps. Refer to Other Concern: Pressure Reference Chart 401 for specifications. If pressure is low, check EPC and main regulator valve. If within specification, check Main Controls.</li> </ul>
<b>Main Controls</b> <ul style="list-style-type: none"> <li>● Solenoid pressure regulator valve, manual valve, torque converter clutch control valve and plunger, converter pressure limit valve, drain back valve stuck, damaged</li> <li>● Loose bolts</li> <li>● Solenoid screen (in valve body) blocked or damaged</li> <li>● TCC solenoid malfunction</li> </ul>	<ul style="list-style-type: none"> <li>● Inspect for damage and service as required.</li> <li>● Tighten bolts to specification.</li> <li>● Clean or replace screen.</li> <li>● Activate solenoid using transmission tester. If solenoid operation cannot be felt when placing hand on solenoid, replace solenoid. Inspect O-rings for damage. Service as required.</li> </ul>

(Continued)

24 Can be purchased as a separate item.

## DIAGNOSIS AND TESTING (Continued)

## TORQUE CONVERTER OPERATION CONCERN: NO APPLY (Cont'd)

Possible Component	Reference / Action
<ul style="list-style-type: none"> <li>● Gaskets damaged</li> </ul>	<ul style="list-style-type: none"> <li>● Inspect for damage and replace.</li> </ul>
<b>Pump Assembly</b> <ul style="list-style-type: none"> <li>● Loose bolts</li> <li>● Porosity / cross leaks, balls leaking</li> <li>● Gaskets damaged</li> </ul>	<ul style="list-style-type: none"> <li>● Tighten bolts to specification.</li> <li>● Inspect for porosity / leaks, ball missing. Replace pump as required.</li> <li>● Inspect for damage and replace.</li> </ul>
<b>Input Shaft</b> <ul style="list-style-type: none"> <li>● Seals damaged</li> </ul>	<ul style="list-style-type: none"> <li>● Inspect for damage. Service as necessary.</li> </ul>
<b>Torque Converter Assembly</b> <ul style="list-style-type: none"> <li>● Leakage, friction material damaged, internal seals damaged</li> </ul>	<ul style="list-style-type: none"> <li>● Inspect torque converter as described. Service or replace as required.</li> </ul>

TD10415K

## TORQUE CONVERTER OPERATION CONCERN: ALWAYS APPLIED / STALLS VEHICLE

Possible Component	Reference / Action
<b>241 — ELECTRICAL ROUTINE</b>	
<b>Powertrain Control System</b> <ul style="list-style-type: none"> <li>● Electrical inputs / outputs, vehicle wiring harnesses, PCM, TP, MAF, VSS, OSS, TR sensor, TCS, shift solenoids, EI system.</li> </ul>	<ul style="list-style-type: none"> <li>● Run self-test. Refer to Powertrain Control / Emissions Diagnosis Manual<sup>25</sup> for diagnosis. Perform Pinpoint Tests A, D and F using Rotunda Transmission Tester 007-00130 with Rotunda AODE / 4R70W Cable and Overlay 007-00122 and Rotunda MLP-C Cable 007-00128 or equivalent, as described. Service as required. Clear codes, road test and rerun self test.</li> </ul>
<b>341 — HYDRAULIC / MECHANICAL ROUTINE</b>	
<b>Main Controls</b> <ul style="list-style-type: none"> <li>● Drain back valve, torque converter clutch and plunger stuck, damaged</li> <li>● Loose bolts</li> <li>● TCC solenoid malfunction</li> <li>● No. 7 ball improper seating</li> <li>● Gaskets damaged</li> </ul>	<ul style="list-style-type: none"> <li>● Inspect for damage and service as required.</li> <li>● Tighten bolts to specification.</li> <li>● Activate solenoid using transmission tester. If solenoid operation cannot be felt when placing hand on solenoid, replace solenoid. Inspect O-rings for damage. Service as required.</li> <li>● Inspect for damage. Service as required.</li> <li>● Inspect for damage and replace.</li> </ul>
<b>Pump Assembly</b> <ul style="list-style-type: none"> <li>● Loose bolts</li> <li>● Ball missing, leaking, porosity / cross leaks</li> <li>● Gaskets damaged</li> </ul>	<ul style="list-style-type: none"> <li>● Tighten bolts to specification.</li> <li>● Inspect for porosity / leaks, balls missing. Replace pump as required.</li> <li>● Inspect for damage and replace.</li> </ul>
<b>Input Shaft</b> <ul style="list-style-type: none"> <li>● Seals damaged</li> </ul>	<ul style="list-style-type: none"> <li>● Inspect for damage. Service as required.</li> </ul>
<b>Torque Converter Assembly</b> <ul style="list-style-type: none"> <li>● No end clearance</li> <li>● Piston plate damaged or stuck to cover</li> </ul>	<ul style="list-style-type: none"> <li>● Inspect converter as described and replace as required.</li> <li>● If cover is heat-stained, replace converter.</li> </ul>

TD10417J

25 Can be purchased as a separate item.

## DIAGNOSIS AND TESTING (Continued)

## TORQUE CONVERTER OPERATION CONCERN: CYCLING/SHUDDER/CHATTER

Possible Component	Reference/Action
<b>242 — ELECTRICAL ROUTINE</b>	
<b>Powertrain Control System</b> <ul style="list-style-type: none"> <li>● Electrical inputs/ outputs, vehicle wiring harnesses, powertrain control module, torque converter clutch (TCC) solenoid, OSS</li> </ul>	<ul style="list-style-type: none"> <li>● Run Self-Test. Refer to Powertrain Control/Emissions Diagnosis Manual<sup>26</sup> for diagnosis. Perform Pinpoint Tests C and F using Rotunda Transmission Tester 007-00130 and Rotunda AODE/4R70W Cable and Overlay 007-00122 or equivalent, as described. Service as required. Clear codes, road test and rerun Self-Test.</li> </ul>
<b>342 — HYDRAULIC/MECHANICAL ROUTINE</b>	
<b>Fluid</b> <ul style="list-style-type: none"> <li>● Condition</li> </ul>	<ul style="list-style-type: none"> <li>● Inspect fluid condition. If burnt, drain fluid and converter. Replace fluid and filter assembly. Bring vehicle to normal operating temperature. Perform Transmission Drive Cycle Test as described. Perform Self-Test. If condition still exists, continue diagnostics.</li> </ul>
<b>Main Controls</b> <ul style="list-style-type: none"> <li>● Solenoid pressure regulator valve, No. 7 check ball, bypass clutch control valve and plunger, converter pressure limit valve stuck, damaged or misassembled</li> <li>● Bolts out of torque specification</li> <li>● Solenoid screen (in valve body) blocked or damaged</li> <li>● TCC solenoid not functioning properly</li> <li>● Gaskets damaged</li> </ul>	<ul style="list-style-type: none"> <li>● Inspect for damage. Service as required.</li> <li>● Tighten bolts to specification.</li> <li>● Clean or replace screen.</li> <li>● Activate solenoid using transmission tester. If solenoid operation cannot be felt when placing hand on solenoid, replace solenoid. Inspect O-rings for damage. Service as required.</li> <li>● Inspect for damage and replace.</li> </ul>
<b>Pump Assembly</b> <ul style="list-style-type: none"> <li>● Bolts out of torque specification</li> <li>● Porosity/cross leaks, balls missing or leaking</li> <li>● Gaskets damaged</li> </ul>	<ul style="list-style-type: none"> <li>● Tighten bolts to specification.</li> <li>● Inspect for porosity/leaks or balls missing. Replace pump assembly as required.</li> <li>● Inspect for damage and replace.</li> </ul>
<b>Input Shaft</b> <ul style="list-style-type: none"> <li>● Seals damaged</li> </ul>	<ul style="list-style-type: none"> <li>● Inspect for damage. Service as required.</li> </ul>
<b>Torque Converter</b> <ul style="list-style-type: none"> <li>● Excessive end clearance</li> </ul>	<ul style="list-style-type: none"> <li>● Inspect converter as outlined. Replace as required.</li> </ul>

## OTHER CONCERNS: NO ENGINE BRAKING IN 2ND GEAR, MANUAL 2ND OR MANUAL 1ST POSITION

Possible Component	Reference/Action
<b>250 — ELECTRICAL ROUTINE</b>	
<ul style="list-style-type: none"> <li>● No Electrical Concerns</li> </ul>	
<b>350 — HYDRAULIC/MECHANICAL ROUTINE</b>	
<b>Shift Linkage</b> <ul style="list-style-type: none"> <li>● Damaged or out of adjustment</li> </ul>	<ul style="list-style-type: none"> <li>● Inspect and service as required. Verify linkage adjustment as described in Section 07-05. After servicing linkage, verify that the TR sensor is properly adjusted. Refer to Transmission, Assembly.</li> </ul>
<b>Main Controls</b> <ul style="list-style-type: none"> <li>● 3-4 shift valve, 1-2 and 2-3 shift valve, gaskets, 3-4 capacity modulator valve, stuck or damaged or misassembled</li> <li>● OD servo assembly damaged or stuck</li> </ul>	<ul style="list-style-type: none"> <li>● Inspect for damage. Service as required.</li> <li>● Inspect cover, piston and seal for damage. Service as required.</li> </ul>
<b>Overdrive</b> <ul style="list-style-type: none"> <li>● OD band, reverse clutch drum assembly worn or damaged</li> <li>● Intermediate overrunning clutch assembly damaged</li> </ul>	<ul style="list-style-type: none"> <li>● Inspect for damage. Service as required.</li> <li>● Inspect for damage. Service as required.</li> </ul>
<b>Reverse Band (Manual 1st Only)</b> <ul style="list-style-type: none"> <li>● Damaged, misadjusted</li> </ul>	<ul style="list-style-type: none"> <li>● Inspect for damage. Service as required.</li> </ul>

TD10421G

26 Can be purchased as a separate item.

## DIAGNOSIS AND TESTING (Continued)

## OTHER CONCERNS: SHIFT LEVER EFFORTS HIGH

Possible Component	Reference / Action
<b>251 — ELECTRICAL ROUTINE</b>	
<ul style="list-style-type: none"> <li>● No Electrical Concerns</li> </ul>	
<b>351 — HYDRAULIC / MECHANICAL ROUTINE</b>	
<b>Shift Linkage, TR Sensor</b> <ul style="list-style-type: none"> <li>● Damaged or out of adjustment</li> </ul>	<ul style="list-style-type: none"> <li>● Inspect and service as required. Verify linkage adjustment as described in Section 07-05. After servicing linkage, verify that the TR sensor is properly adjusted. Refer to Transmission, Assembly.</li> </ul>
<b>Manual Lever</b> <ul style="list-style-type: none"> <li>● Retaining pin damaged, nut loose, detent spring bent or damaged or PARK mechanism damaged</li> </ul>	<ul style="list-style-type: none"> <li>● Inspect for damage. Service as required.</li> </ul>
<b>Main Controls</b> <ul style="list-style-type: none"> <li>● Manual valve stuck or damaged</li> <li>● Bolts out of torque specification</li> </ul>	<ul style="list-style-type: none"> <li>● Inspect for damage. Service as required.</li> <li>● Tighten bolts to specification.</li> </ul>

TD10423G

## OTHER CONCERNS: EXTERNAL LEAKS

Possible Component	Reference / Action
<b>252 — ELECTRICAL ROUTINE</b>	
<b>Powertrain Control System</b> <ul style="list-style-type: none"> <li>● Electrical inputs / outputs, sensor seals leaking (TR, OSS, VSS or transmission connector)</li> </ul>	<ul style="list-style-type: none"> <li>● Inspect for leakage and service as required.</li> </ul>
<b>352 — HYDRAULIC / MECHANICAL ROUTINE</b>	
<b>Seals, Gaskets</b> <ul style="list-style-type: none"> <li>● Torque converter, pump assembly, pan, extension housing - gasket / seal, manual lever, fluid level indicator tube</li> </ul>	<ul style="list-style-type: none"> <li>● Locate source of leak. Service as required.</li> </ul>
<b>Other</b> <ul style="list-style-type: none"> <li>● Cooler fitting, pressure taps, converter drain plug, band anchor pins, cooler lines, case porosity, case cracked</li> <li>● Vent blocked or damaged</li> </ul>	<ul style="list-style-type: none"> <li>● Locate source of leak. Service as required.</li> <li>● Check vent for damage or blockage. Service as required.</li> </ul>

TD10425G

## OTHER CONCERNS: POOR VEHICLE PERFORMANCE

Possible Component	Reference / Action
<b>253 — ELECTRICAL ROUTINE</b>	
<b>Powertrain Control System</b> <ul style="list-style-type: none"> <li>● Electrical inputs / outputs, vehicle wiring harnesses, shift solenoids, TR sensor, torque converter clutch (TCC) solenoid, transmission oil temperature (TOT) sensor</li> </ul>	<ul style="list-style-type: none"> <li>● Run Self-Test. Refer to Powertrain Control / Emissions Diagnosis Manual<sup>27</sup> for diagnosis. Perform Pinpoint Tests A, B, C and D using Rotunda Transmission Tester 007-00130 with Rotunda AODE / 4R70W Cable and Overlay 007-00122 and Rotunda MLP-C Cable 007-00128 or equivalent, as described. Service as required. Clear codes, road test and rerun Self-Test. Also refer to Routines 241 / 341 Torque Converter Operation Concern: Always Applied / Stalls Vehicle.</li> </ul>
<b>353 — HYDRAULIC / MECHANICAL ROUTINE</b>	
<b>Shift Linkage, TR Sensor</b> <ul style="list-style-type: none"> <li>● Damaged or out of adjustment</li> </ul>	<ul style="list-style-type: none"> <li>● Inspect and service as required. Verify linkage adjustment as described in Section 07-05. After servicing linkage, verify that the TR sensor is properly adjusted. Refer to Transmission, Assembly.</li> </ul>

(Continued)

27 Can be purchased as a separate item.

**DIAGNOSIS AND TESTING (Continued)**

**OTHER CONCERNS: POOR VEHICLE PERFORMANCE (Cont'd)**

Possible Component	Reference / Action
Verify Proper Shift Scheduling and Engagements	<ul style="list-style-type: none"> <li>● Go to the appropriate Diagnostic Routines.</li> </ul>
Torque Converter Clutch Always Applied	<ul style="list-style-type: none"> <li>● Go to Hydraulic / Mechanical Routine 241 / 341.</li> </ul>
Torque Converter Clutch <ul style="list-style-type: none"> <li>● Damaged</li> </ul>	<ul style="list-style-type: none"> <li>● Inspect torque converter as described. Replace as described.</li> </ul>

TD10427K

**OTHER CONCERNS: NOISE / VIBRATION — FORWARD OR REVERSE**

Possible Component	Reference / Action
<b>254 — ELECTRICAL ROUTINE</b>	
<ul style="list-style-type: none"> <li>● No Electrical Concerns</li> </ul>	
<b>354 — HYDRAULIC / MECHANICAL ROUTINE</b>	
<b>For Noises / Vibrations That Change With Engine Speed:</b> <ul style="list-style-type: none"> <li>● Converter components</li> <li>● Fluid level (low) pump cavitation</li> <li>● Pump assembly</li> <li>● Engine drive accessories</li> <li>● Cooler lines grounding out</li> <li>● Flywheel</li> </ul>	<ul style="list-style-type: none"> <li>● Locate source of disturbance. Service as required.</li> </ul>
<b>For Noises / Vibrations That Change With Vehicle Speed:</b> <ul style="list-style-type: none"> <li>● Engine mounts loose or damaged</li> <li>● Driveline concerns:                             <ul style="list-style-type: none"> <li>— u-joints</li> <li>— rear axle</li> <li>— suspension</li> <li>— modifications</li> </ul> </li> <li>● First Gear:                             <ul style="list-style-type: none"> <li>— low one-way clutch</li> <li>— gearset</li> <li>— friction elements</li> </ul> </li> <li>● Second Gear:                             <ul style="list-style-type: none"> <li>— intermediate one-way clutch</li> <li>— intermediate clutch piston bleed hole out of 12 O'clock position</li> <li>— friction elements</li> </ul> </li> <li>● Third Gear:                             <ul style="list-style-type: none"> <li>— torque converter</li> <li>— anti-clunk spring</li> <li>— friction elements</li> </ul> </li> <li>● Fourth Gear:                             <ul style="list-style-type: none"> <li>— gear set</li> <li>— friction elements</li> <li>— torque converter</li> </ul> </li> <li>● Reverse:                             <ul style="list-style-type: none"> <li>— gear set</li> <li>— friction elements</li> </ul> </li> <li>● Output shaft splines worn or damaged</li> </ul>	<ul style="list-style-type: none"> <li>● Locate source of disturbance and service as required.</li> </ul> <ul style="list-style-type: none"> <li>● For specific shift or torque converter concerns, refer to the following routine(s) for further diagnosis:  <b>Shift 1-2, Routine, 320</b>  <b>Shift 2-3, Routine, 321</b>  <b>Shift 3-4, Routine, 322</b>  <b>Shift 4-3, Routine, 323</b>  <b>Shift 3-2, Routine, 324</b>  <b>Shift 2-1, Routine, 325</b>  <b>Torque Converter Cycling 242 / 342</b></li> </ul>
<b>Other Noises / Vibrations:</b> <ul style="list-style-type: none"> <li>● Main Controls, valve resonance</li> <li>● Shift Cable:                             <ul style="list-style-type: none"> <li>— vibration</li> <li>— grounding</li> <li>— cooler lines</li> <li>— grounding</li> </ul> </li> </ul>	<ul style="list-style-type: none"> <li>● Locate source of disturbance and service as required.</li> </ul>

## DIAGNOSIS AND TESTING (Continued)

## OTHER CONCERNS: ENGINE WILL NOT CRANK

Possible Component	Reference / Action
<b>255 — ELECTRICAL ROUTINE</b>	
<b>Powertrain Control System</b> <ul style="list-style-type: none"> <li>Electrical inputs / outputs, vehicle wiring harnesses, engine starting system hardware, TR sensor</li> </ul>	<ul style="list-style-type: none"> <li>Run Self-Test. Refer to Powertrain Control/Emissions Diagnosis Manual<sup>26</sup> for diagnosis. Perform Pinpoint Test D using Rotunda MLP-C Cable 007-00128 and Rotunda AODE / 4R70W Cable and Overlay 007-00122 or equivalent, as described. Service and adjust as required.</li> </ul>
<b>355 — HYDRAULIC/MECHANICAL ROUTINE</b>	
<b>Shift Linkage, TR Sensor</b> <ul style="list-style-type: none"> <li>Damaged or out of adjustment</li> </ul>	<ul style="list-style-type: none"> <li>Inspect and service as required. Verify linkage adjustment as described in Section 07-05. After servicing linkage, verify that the TR sensor is properly adjusted. Refer to Transmission, Assembly.</li> </ul>

TD10431H

## OTHER CONCERNS: NO PARK RANGE

Possible Component	Reference / Action
<b>256 — ELECTRICAL ROUTINE</b>	
<ul style="list-style-type: none"> <li>No Electrical Concerns</li> </ul>	
<b>356 — HYDRAULIC/MECHANICAL ROUTINE</b>	
<b>Shift Linkage, TR Sensor</b> <ul style="list-style-type: none"> <li>Damaged or out of adjustment</li> </ul>	<ul style="list-style-type: none"> <li>Inspect and service as required. Verify linkage adjustment as described in Section 07-05. After servicing linkage, verify that the TR sensor is properly adjusted. Refer to Transmission, Assembly.</li> </ul>
<b>Park Mechanism</b> <ul style="list-style-type: none"> <li>Output shaft ring, park brake pawl, parking pawl return spring, park rod guide cup, parking pawl shaft, parking pawl actuating rod, manual lever, manual lever detent spring damaged or misassembled</li> </ul>	<ul style="list-style-type: none"> <li>Inspect for damage or misassembly and service as required.</li> </ul>

TD10433F

## OTHER CONCERNS: TRANSMISSION OVERHEATING

Possible Component	Reference / Action
<b>257 — ELECTRICAL ROUTINE</b>	
<b>Refer to Routine 240/340, Torque Converter Operation Concern: No Apply</b>	
<b>357 — HYDRAULIC/MECHANICAL ROUTINE</b>	
<b>Fluid</b> <ul style="list-style-type: none"> <li>Improper level</li> <li>Condition</li> </ul>	<ul style="list-style-type: none"> <li>Adjust fluid to proper level.</li> <li>Inspect as described under Fluid Condition Check.</li> </ul>
<b>Cooler Lines</b> <ul style="list-style-type: none"> <li>Damaged, blocked or reversed</li> </ul>	<ul style="list-style-type: none"> <li>Inspect for damage and proper installation. Service as required.</li> </ul>
<b>Auxiliary Cooler</b> <ul style="list-style-type: none"> <li>Damaged, blocked or restricted or improperly installed</li> </ul>	<ul style="list-style-type: none"> <li>Inspect for damage and proper installation. Service as required.</li> </ul>
<b>Vehicle Concerns Causing Engine Overheating</b>	<ul style="list-style-type: none"> <li>Refer to Section 03-03.</li> </ul>
<b>Main Controls</b> <ul style="list-style-type: none"> <li>Drain back valve, torque clutch control valve, converter limit valve stuck, damaged or misassembled</li> </ul>	<ul style="list-style-type: none"> <li>Inspect for damage and service as required.</li> </ul>
<b>Torque Converter</b> <ul style="list-style-type: none"> <li>No Apply</li> </ul>	<ul style="list-style-type: none"> <li>Refer to Routine 240/340.</li> </ul>

TD10435F

26 Can be purchased as a separate item.

## DIAGNOSIS AND TESTING (Continued)

**CAUTION:** Do not install Transmission Tester when verifying these pressures.

**NOTE:** Vehicle harness must be installed at transmission connector to verify these pressures.

**NOTE:** Pressures may vary with model.

## REFERENCE: PRESSURE CHART #401

Application	Range	Idle		WOT Stall	
		EPC	Line Pressure	EPC	Line Pressure
4.6L Thunderbird, Cougar	P, N, OD, 2, 1	7-17 PSI	43-81 PSI	83-93 PSI	160-210 PSI
	R	7-17 PSI	68-112 PSI	83-93 PSI	207-267 PSI
3.8L Thunderbird, Cougar	P, N, OD, 2, 1	15-25	55-94	83-93	160-210
	R	3-13	60-104	83-93	207-267

## REFERENCE: BAND / CLUTCH APPLICATION CHART #601

Gear	Overdrive Band	Low Reverse Band	Forward Clutch	Direct Clutch	Interim Friction Clutch	Reverse Clutch	Interim One-Way Clutch	Planetary One-Way Clutch
1st Gear Manual Low		Applied	Applied					Holding
2nd Gear Manual Low	Applied		Applied		Applied		Holding	
1st Gear D (OVERDRIVE) or D(3)			Applied					Holding
2nd Gear D (OVERDRIVE) or D(3)			Applied		Applied		Holding	
3rd Gear D (OVERDRIVE) or D(3)			Applied	Applied	Applied			
4th Gear D (OVERDRIVE)	Applied			Applied	Applied			
Reverse (R)		Applied				Applied		

## REFERENCE: SOLENOID OPERATION CHART #701

Transmission Range Selector Lever Position	PCM Commanded Gear	Solenoids		
		SS-1	SS-2	TCC
P/R/N	1	ON	OFF	HD
D	1	ON	OFF	HD
D	2	OFF	OFF	EC
D	3	OFF	ON	EC
D	4	ON	ON	EC
D w/OD OFF				
1	1	ON	OFF	HD
2	2	OFF	OFF	EC
3	3	OFF	ON	EC
Manual 2	2	OFF	OFF	EC
Manual 1	1	ON	OFF	HD
1 <sup>a</sup>	2	OFF	OFF	EC

a When a manual pull-in occurs above a calibrated speed the transmission will downshift from the higher gear until the vehicle speed drops below this calibrated speed.

EC = Electronically Controlled

HD = Hydraulically Disabled

## IN-VEHICLE SERVICE

## Transmission Fluid Drain and Refill

Normal maintenance and lubrication requirements necessitate periodic automatic transmission fluid changes. If a major service, such as a clutch, band, bearing, etc., is required, the transmission will have to be removed for service. At this time, the torque converter (7902), transmission fluid cooler and fluid cooler tubes must be thoroughly flushed to remove any dirt. When used under continuous or severe conditions, the transmission and torque converter should be drained and refilled with fluid as specified.

**CAUTION:** Use of a fluid other than specified could result in transmission malfunction and/or failure.

Refer to the Vehicle Certification Label affixed to the LH front door lock face panel or door pillar for the transmission code.

When filling a dry transmission or torque converter, refer to Specifications for capacity. Check the fluid level.

Procedures for partial drain and refill, due to in-vehicle service operation, are as follows:

1. Raise and suitably support vehicle on a hoist or jack stands. Refer to Section 00-02.

**IN-VEHICLE SERVICE (Continued)**

2. Place drain pan under transmission.
3. Loosen transmission pan retaining bolts and drain fluid from transmission.
4. When fluid has drained to level of pan flange, remove the remaining pan bolts working from the RH side allowing the pan to lower and drain slowly.
5. Drain the torque converter by removing the torque converter drain plug.
6. After the torque converter has been drained, install a new torque converter drain plug and tighten to 28-30 N·m (21-22 lb-ft).
7. When all fluid has been drained from transmission, remove and thoroughly clean the transmission pan.
8. NOTE: Transmission oil pan to case gasket (7A191) is reusable if not damaged.  
Clean, inspect and install oil pan to case gasket on transmission pan, and install transmission pan on transmission.
9. Lower vehicle.
10. When filling a dry transmission and converter, start with a minimum of 6.1 liters (6.5 quarts). Refer to Specifications for capacity.
11. Fill transmission to proper level using Motorcraft MERCON® Multi-Purpose (ATF) Transmission Fluid XT-2-QDX or equivalent fluid meeting MERCON® specification.

**Vehicle Speed Sensor (VSS)****Removal**

1. Raise vehicle on a hoist. Refer to Section 00-02. Remove bolt retaining vehicle speed sensor mounting clip to transmission.
2. Remove vehicle speed sensor (VSS)(9E731) and driven gear from transmission.
3. Disconnect electrical connector from vehicle speed sensor.
4. Remove driven gear retainer and remove driven gear from sensor.

**Installation**

1. Position driven gear to vehicle speed sensor. Install gear retainer.
2. Connect electrical connector.
3. Make sure that internal O-ring (3Z728) is properly seated in the sensor housing.
4. Insert vehicle speed sensor assembly into transmission housing. Install retaining bolt and tighten to 7-10 N·m (62-88 lb-in).
5. Lower vehicle.

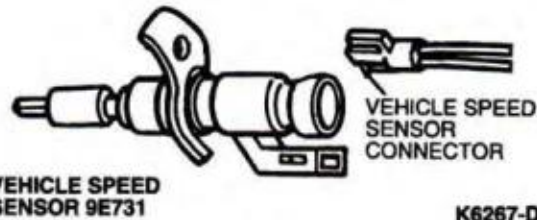
**Extension Housing Seal, Gasket and Bushing Removal****SPECIAL SERVICE TOOL(S) REQUIRED**

Description	Tool Number
Seal Remover	T74P-77248-A
Extension Housing Bushing Remover	T77L-7697-A
Extension Housing Bushing Replacer	T80L-77034-A
Extension Housing Seal Replacer	T61L-7657-A
Impact Slide Hammer	T50T-100-A

1. Disconnect the battery ground cable (14301). Refer to Section 14-01.
2. Raise vehicle on a hoist. Refer to Section 00-02.
3. Remove muffler inlet pipe and resonator (5A289). Refer to Section 09-00.
4. Drain transmission fluid as described.
5. Remove driveshaft. Refer to Section 05-01.
6. Disconnect and remove the vehicle speed sensor (VSS)(9E731) from the extension housing (7A039).
7. Position a transmission jack under the transmission and raise it slightly.
8. Remove the engine rear support-to-crossmember bolts.
9. Remove the crossmember-to-frame side support retaining bolts and remove the engine and transmission support insulator (6F063) and engine and transmission support (6F065) and engine damper mounting body bracket (6F067).
10. Lower the jack under the transmission and allow the transmission to hang.
11. NOTE: The extension housing bolts have been coated with a sealant. More break torque may be required to remove these bolts.  
Remove six extension housing bolts. Slide extension housing off output shaft. Remove and discard extension housing gasket (7086).

**IN-VEHICLE SERVICE (Continued)**

12. Remove extension housing seal using Seal Remover T74P-77248-A. Make sure seal remover lips are firmly seated under the flange on the extension housing seal.

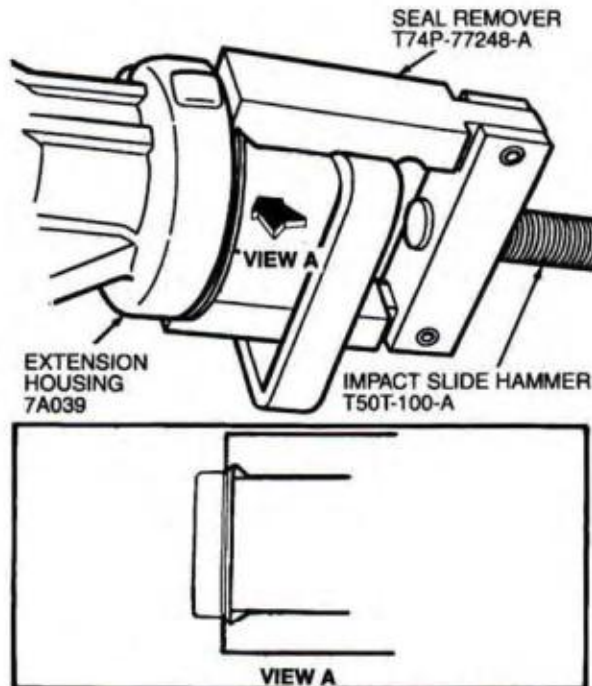

AD0319-A

13. Inspect extension housing bushing (7A034). If necessary, remove extension housing bushing using Extension Housing Bushing Remover T77L-7697-A.

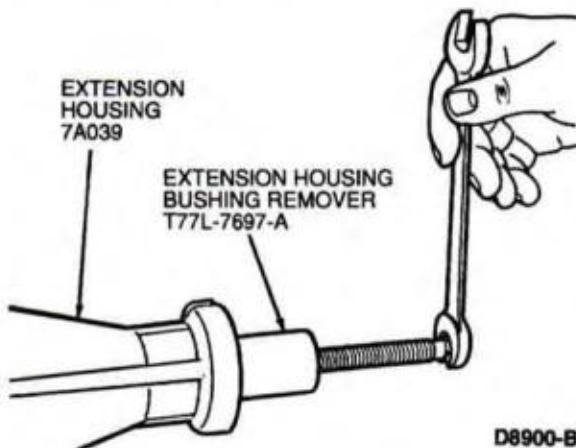
**Installation**

1. If removed, install new extension housing bushing using Extension Housing Bushing Replacer T80L-77034-A.
2. Install new extension housing gasket and extension housing. Tighten six bolts to 25-30 N-m (18-22 lb-ft).

3. Install new extension housing seal using Extension Housing Seal Replacer T61L-7657-A.
4. Raise the transmission. Position the engine and transmission support insulator and engine and transmission support and engine damper mounting body bracket to the frame side supports and install the retaining bolts. Refer to Section 02-03 for torque specifications.
5. Lower the transmission and install the rear engine support-to-crossmember nut. Refer to Section 02-03.
6. Remove the transmission jack.
7. Connect the muffler inlet pipe and resonator to the exhaust manifold (9430). Refer to Section 09-00.
8. Install the vehicle speed sensor and connect wiring.
9. Install the driveshaft (4602). Refer to Section 05-01.
10. Remove safety stands and lower the vehicle. Connect the battery ground cable. Refer to Section 14-01.
11. Pour 4.7 liters (5 quarts) of specified fluid into fluid filler tube. Start engine and add fluid as required to achieve the proper fluid level as outlined.
12. Check the transmission assembly for leaks.

**Main Control Valve Body****Removal**

1. Disconnect the battery ground cable (14301). Refer to Section 14-01.
2. Raise vehicle on a hoist. Refer to Section 00-02.
3. Drain transmission fluid as described.
4. Remove 14 pan retaining bolts, transmission pan and pan-to-case gasket. Clean and inspect pan to case gasket.

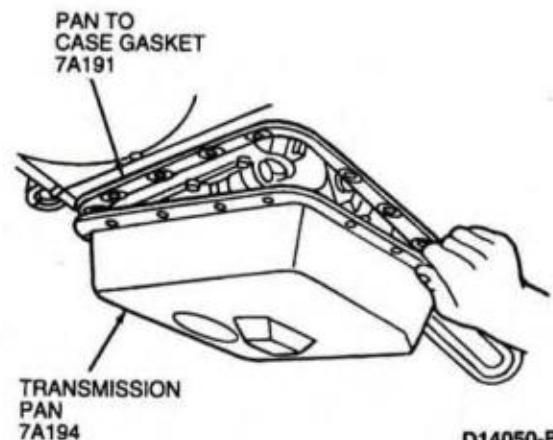

## IN-VEHICLE SERVICE (Continued)

5. Remove pan magnet. Clean transmission pan and pan magnet.

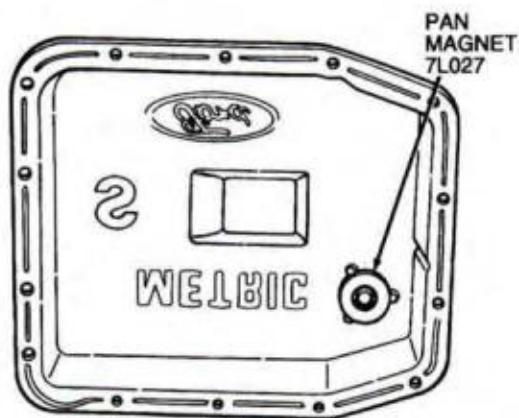

D10254-D

6. **CAUTION:** If installing a new filter, and grommet remains in the main control bore, carefully use a small screwdriver to remove the grommet. Use care not to damage the main control bore.

**NOTE:** If transmission is being serviced for a contamination-related failure, use a new filter and grommet. The filter may be reused if no excessive contamination is present.

Using both hands, remove filter by pulling downward.

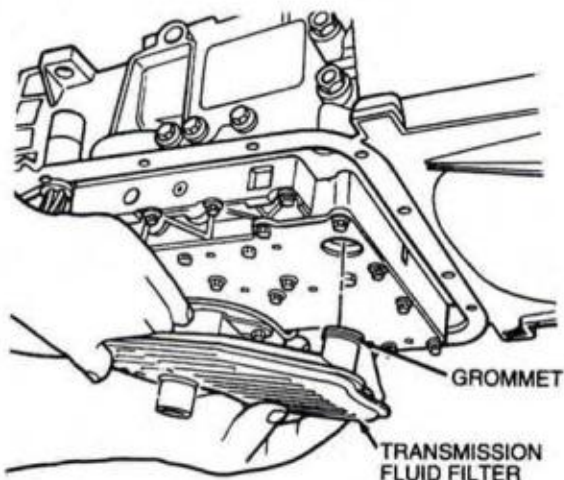

D14046-B

7. **CAUTION:** Do not pull on wires. This may damage wires or connector and could result in a transmission concern. If required, carefully pry up on locking tab and disconnect the connector.

Grasp connector at each solenoid or sensor and pull straight out to disconnect.

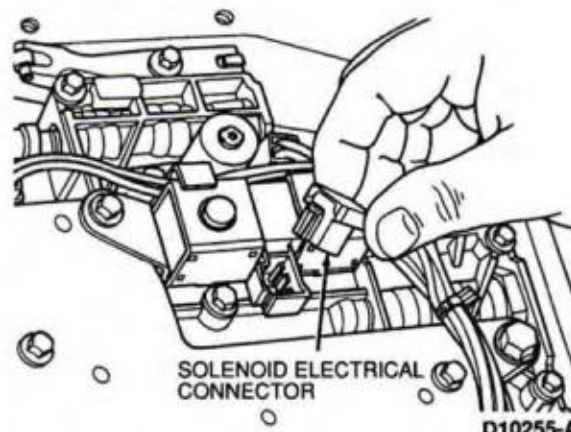

8. Remove one bolt retaining manual control valve detent lever spring (7A261) to the main control valve body (7A100).
9. Remove electronic pressure control (EPC) solenoid bracket retaining bolt. Remove bracket.

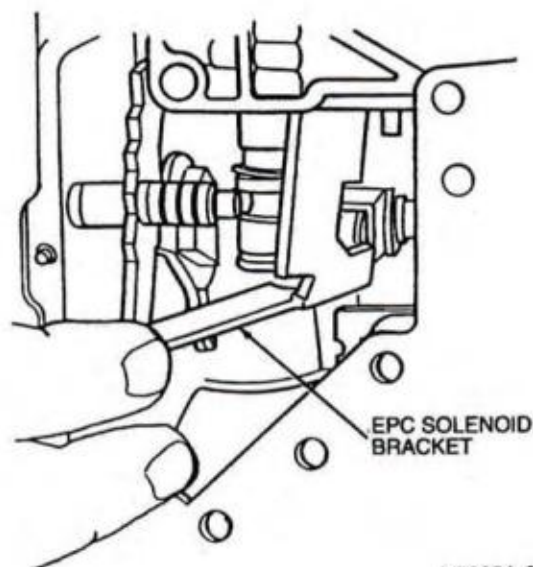

AD0321-A

**IN-VEHICLE SERVICE (Continued)**

10. Remove remaining 24 valve body-to-case retaining bolts, the main control valve body and the valve-to-body gasket.

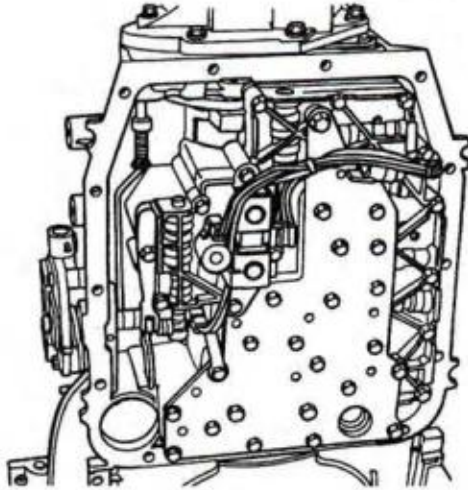

D14048-B

**Installation**

1. Position main control valve body using the two alignment bolts as a guide.
2. Install the electronic pressure control (EPC) solenoid bracket. Loosely install one long 6 mm bolt.

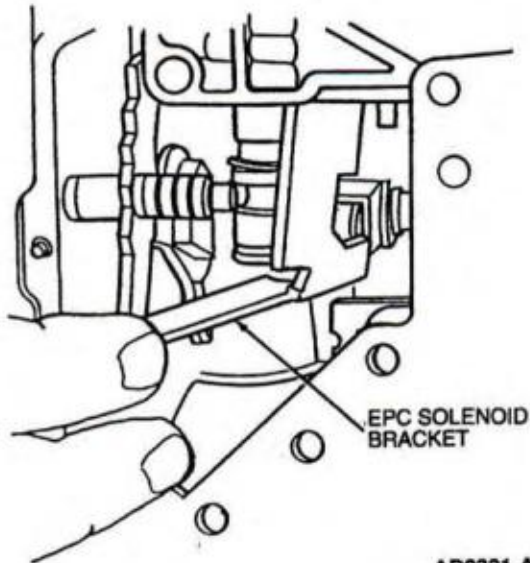

AD0321-A

3. Loosely install 11 long and 12 short bolts.

4. Install manual control valve detent lever spring and one bolt.

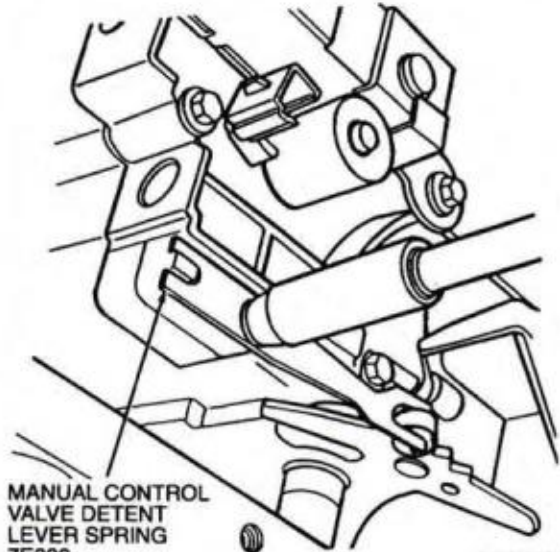

AD0322-A

5. Tighten the 25 main control-to-case valve body bolts to 9-11 N·m (80-100 lb-in).

**Main Control to Case**

**INSTALLATION**

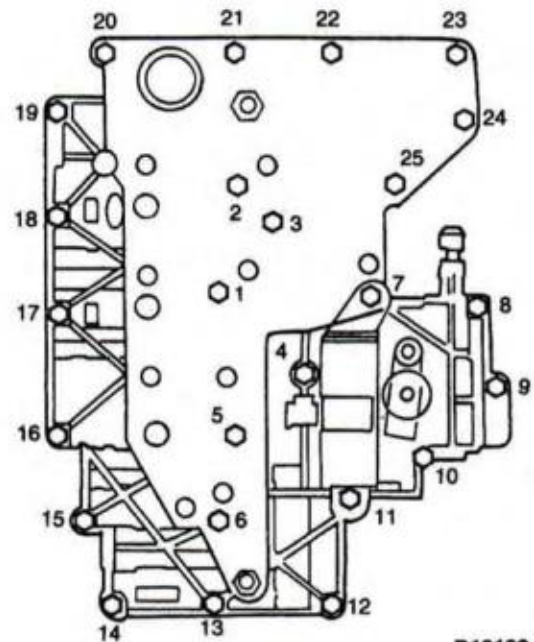

D12122-C

## IN-VEHICLE SERVICE (Continued)

6. Connect wiring connectors to transmission fluid temperature sensor (TFT sensor), shift solenoids (7G484), TCC solenoid and EPC solenoid.

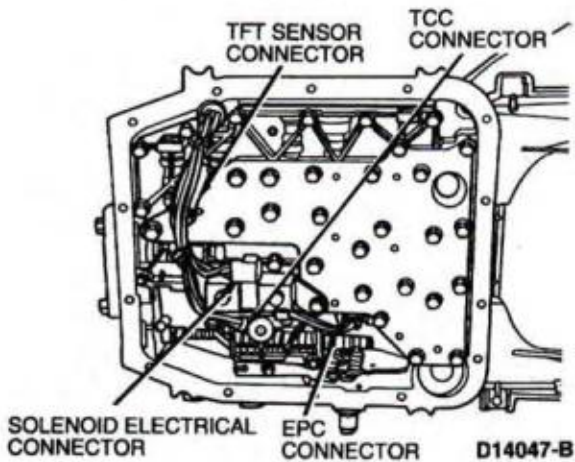

7. Install filter and grommet.

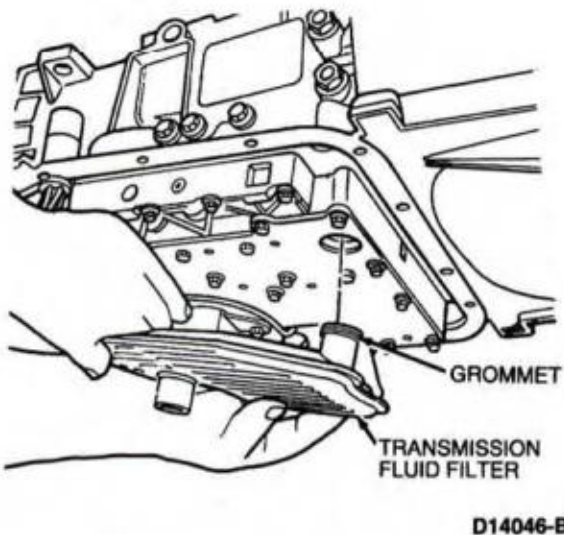

8. Install pan magnet to transmission pan.

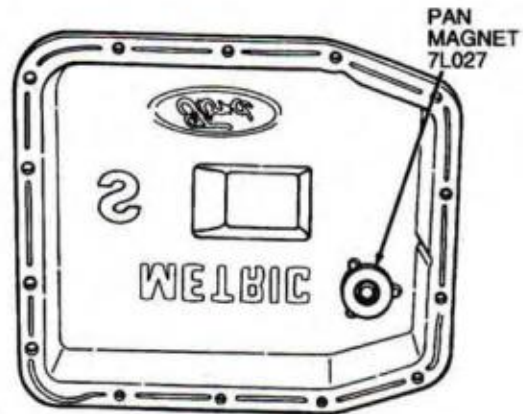

9. NOTE: Transmission pan-to-case gasket is reuseable if not damaged.

Clean, inspect and install pan-to-case gasket and transmission pan. Tighten all bolts to 12-15 N·m (9-11 lb-ft).

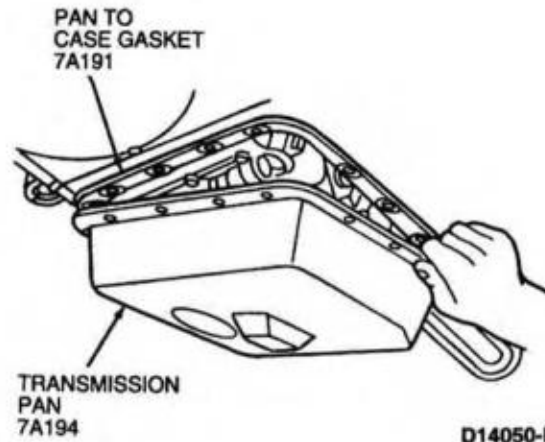

10. Lower vehicle.
11. Pour 4.7 liters (5 quarts) of Motorcraft MERCON® Multi-Purpose (ATF) Transmission Fluid XT-2-QDX or equivalent MERCON® approved fluid into filler tube.
12. Connect battery ground cable. Refer to Section 14-01.
13. Start the engine and add specified fluid as required to achieve the proper fluid level as described.
14. Check the transmission for leaks.

## IN-VEHICLE SERVICE (Continued)

## Electronic Pressure Control (EPC) Solenoid

## SPECIAL SERVICE TOOL(S) REQUIRED

Description	Tool Number
Transmission Range (TR) Sensor MLPS Alignment Tool	T93P-70010-A

## Removal

1. Open hood and disconnect the battery ground cable (14301). Refer to Section 14-01.
2. Raise vehicle on a hoist. Refer to Section 00-02.
3. Drain transmission fluid as described.
4. Remove 14 pan retaining bolts, transmission pan and pan to case gasket.

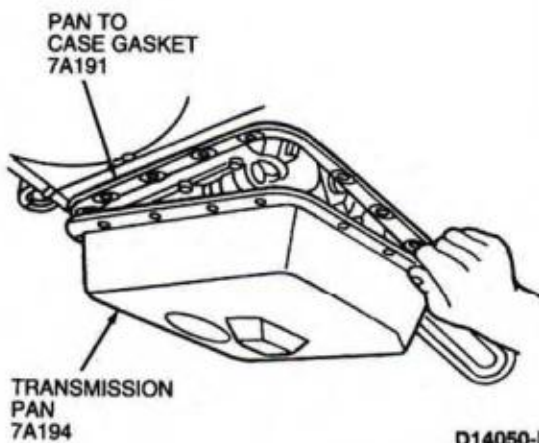

5. Remove pan magnet. Clean transmission pan and pan magnet.

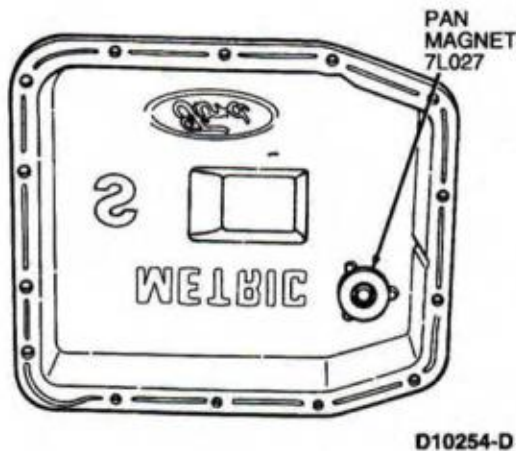

6. **CAUTION:** If installing a new filter, and grommet remains in the main control bore, carefully use a small screwdriver to remove the grommet. Use care not to damage the main control bore.

**NOTE:** If transmission is being serviced for a contamination-related failure, use a new filter and grommet. The filter may be reused if no excessive contamination is present.

Using both hands, remove filter by pulling downward.

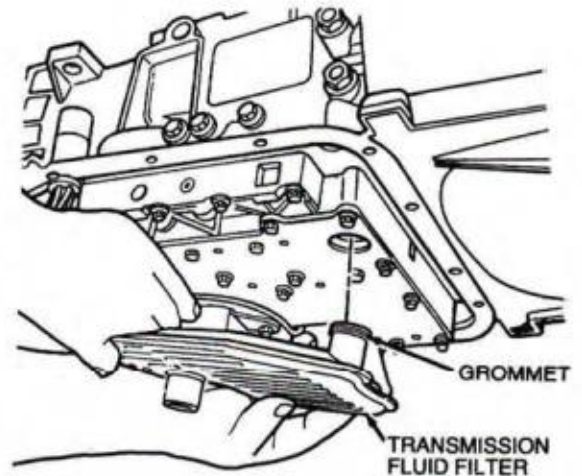

7. Remove one bolt retaining manual control valve detent lever spring (7A261) to the main control valve body (7A100). Remove manual control valve detent lever spring.

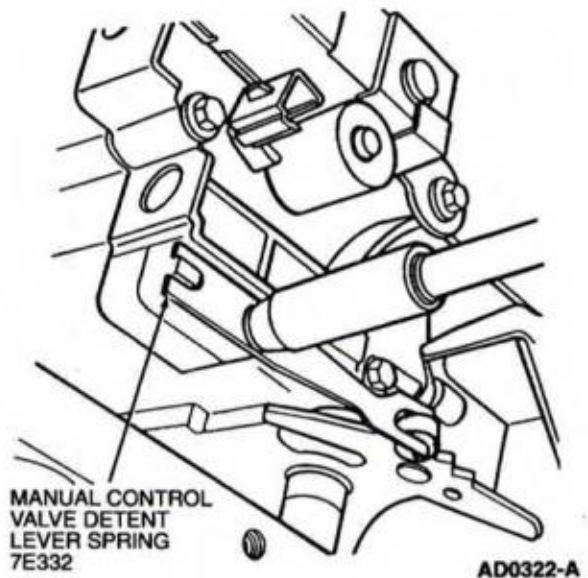

## IN-VEHICLE SERVICE (Continued)

8. Disconnect transmission shift linkage from manual control lever by removing the nut.
9. Remove two bolts retaining transmission range (TR) sensor to case (7005). Remove transmission range (TR) sensor from manual control lever (7A256).

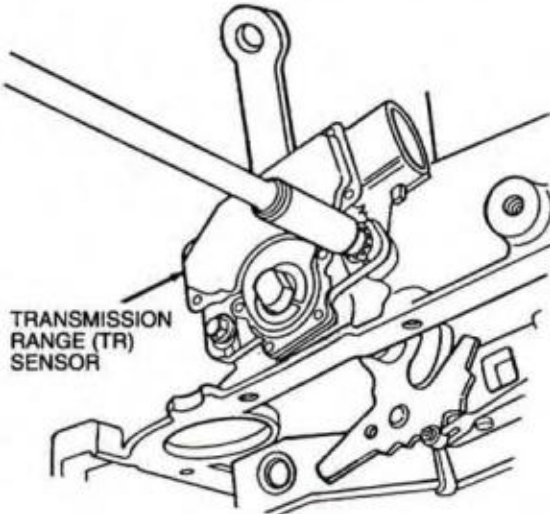

D14698-A

10. NOTE: For clarity, the following illustrations show the main control valve body removed. It is not necessary to remove the main control valve body for this procedure.

Remove the EPC solenoid bracket retaining bolt. Remove the EPC solenoid bracket.

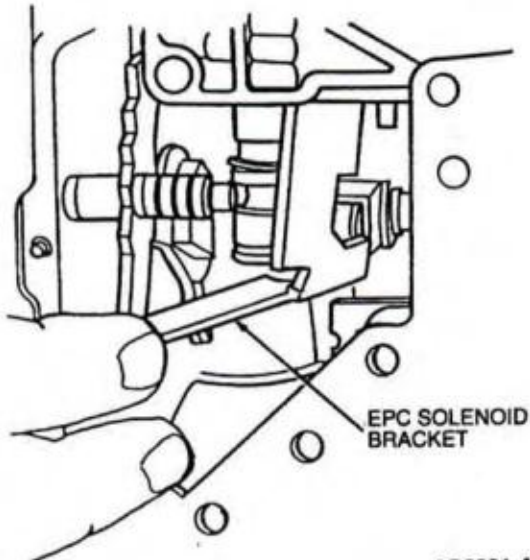

AD0321-A

11. NOTE: Use a shop cloth to protect pan-to-case surface.  
Remove manual lever shaft retaining pin (7B210).

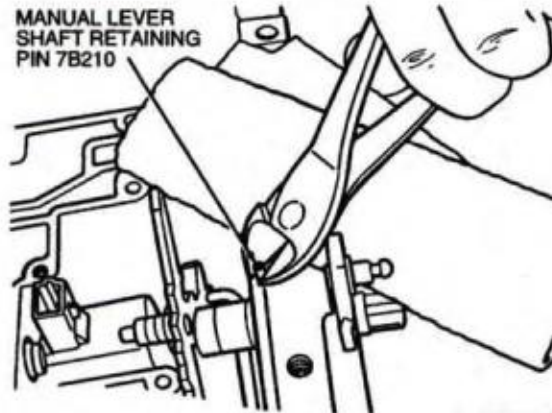

D8890-B

12. Using a 13/16-inch open-end wrench on the inner nut and a 12 mm wrench on the manual control lever shaft flats, loosen the inner nut.

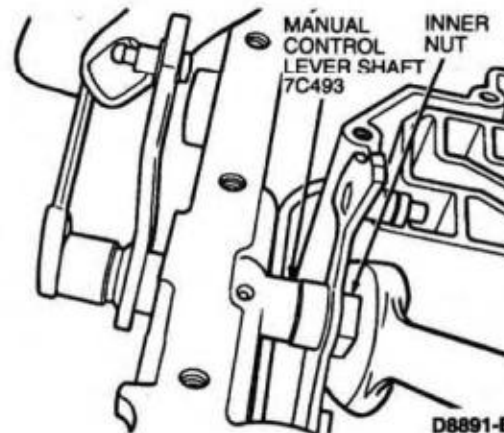

D8891-B

Slide manual control lever partially out of the case to complete removal of the inner nut from manual control lever.

## IN-VEHICLE SERVICE (Continued)

13. Slide manual control lever out of case. Position manual valve detent lever (7A115) so that EPC solenoid can be removed. Remove EPC solenoid connector by grasping connector body and pulling. Remove EPC solenoid by sliding it out of the case bore.

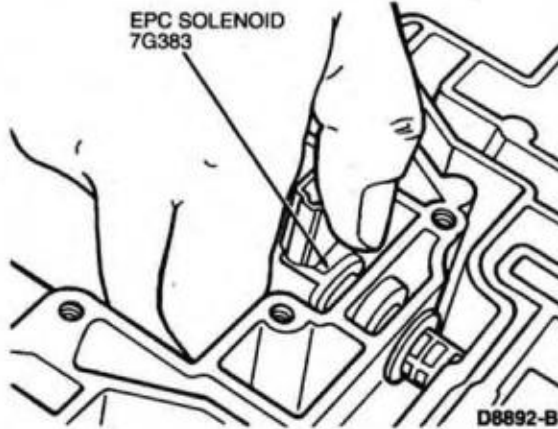

## Installation

1. Lubricate EPC solenoid seal and O-ring with a light coating of Motorcraft MERCON® Multi-Purpose (ATF) Transmission Fluid XT-2-QDX or equivalent MERCON® approved fluid. Install EPC solenoid by sliding it into the bore.

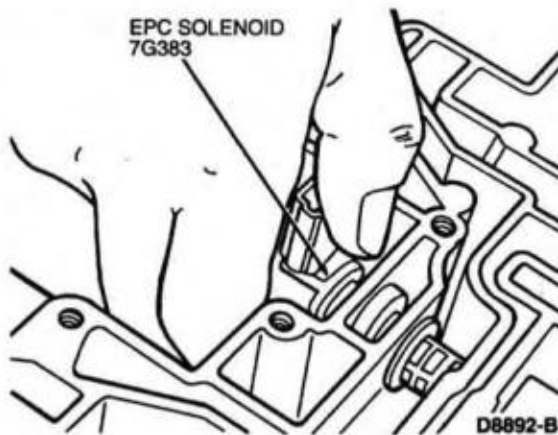

2. Install the EPC solenoid bracket. Install bolt and tighten to 11-15 N·m (98-132 lb-in).

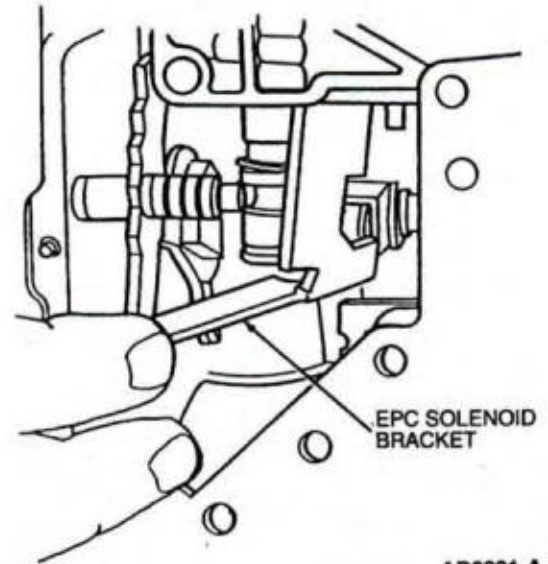

AD0321-A

3. Install connector to EPC solenoid by pushing connector body in place.
4. Position manual valve detent lever and parking lever actuating rod (7A232) into case. Parking lever actuating rod must be positioned over parking pawl (7A441).
5. Slide manual control lever into case and position through detent. Install nut and tighten to 26-37 N·m (20-27 lb-ft).
6. Install manual lever shaft retaining pin.
7. Install TR sensor on manual control lever and two shims, then loosely install bolts.

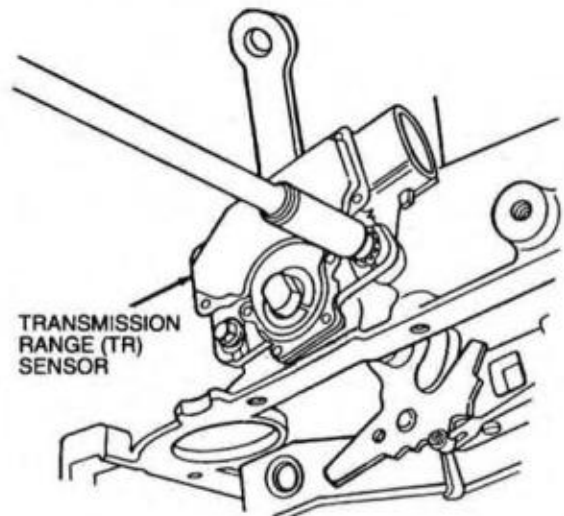

D14698-A

## IN-VEHICLE SERVICE (Continued)

8. **NOTE:** PARK is the last detent when the manual control lever is full forward. Return two detents toward output shaft (7060) for NEUTRAL. Position manual control lever in NEUTRAL.
9. Insert Transmission Range (TR) Sensor Alignment MLPS Tool T93P-70010-A into slots. Align all three slots on transmission range (TR) sensor with three tabs on tool.

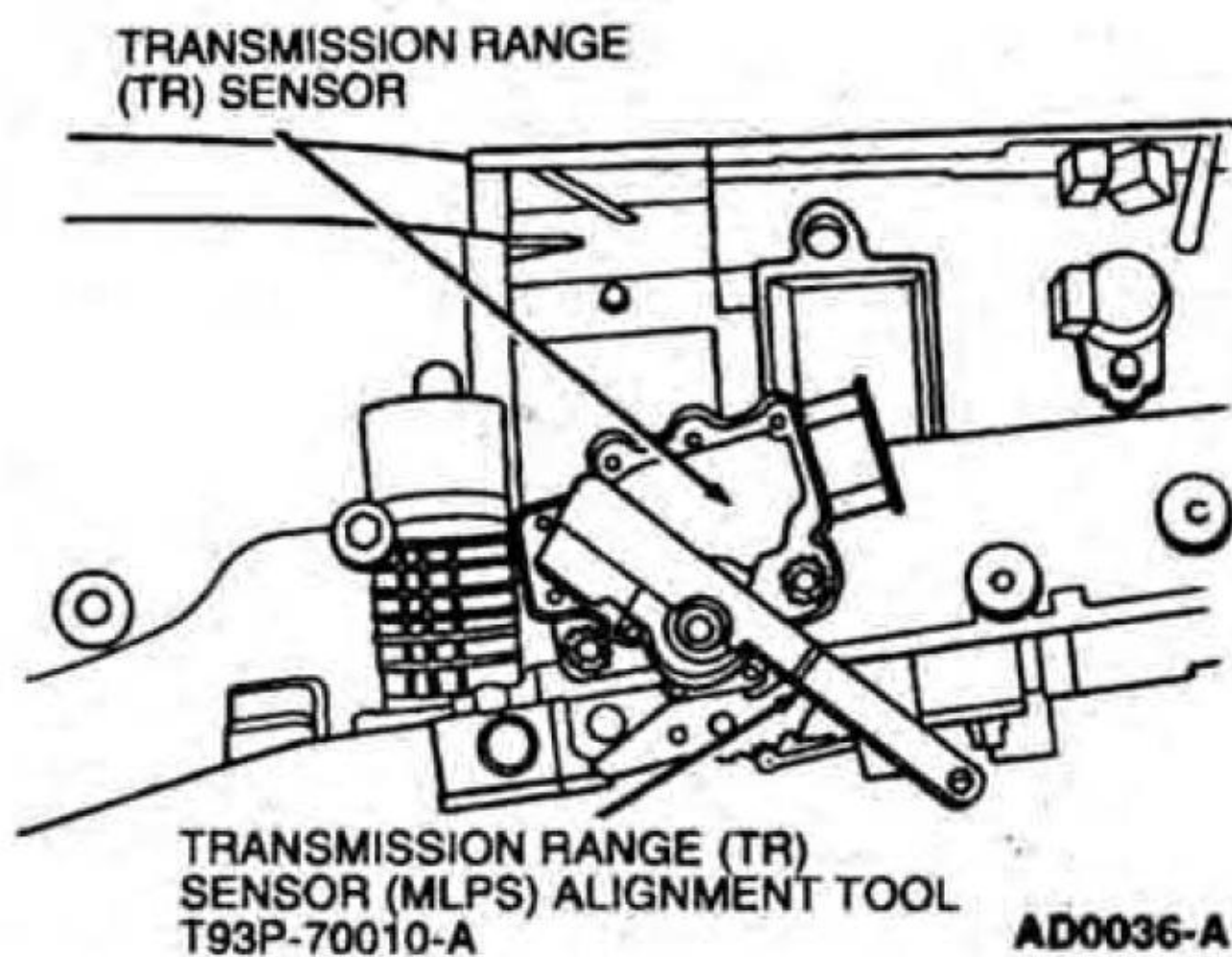

10. Tighten TR sensor bolts to 7-10 N·m (62-89 lb-in).
11. Install manual control valve detent lever spring and bolt. Tighten bolt to 11-15 N·m (98-132 lb-in).
12. **NOTE:** Transmission pan-to-case gasket is reuseable if not damaged. Clean, inspect and install pan-to-case gasket. Tighten all bolts to 12-15 N·m (9-11 lb-ft).
13. Attach transmission linkage to manual control lever. Tighten adjusting nut to 19-26 N·m (14-19 lb-ft).
14. Pour 4.7 liters (5 quarts) of Motorcraft MERCON® Multi-Purpose (ATF) Transmission Fluid XT-2-QDX or equivalent MERCON® approved fluid into oil filler tube (7A228).
15. Reconnect battery ground cable. Refer to Section 14-01.
16. Start the engine and add specified fluid as required to achieve the proper fluid level as described.
17. Check the transmission for leaks.

ProCarManuals.com

### Main Control Components

#### SPECIAL SERVICE TOOL(S) REQUIRED

Description	Tool Number
Servo Piston Remover / Replacer	T92P-70023-A
Servo Piston Selection Tool	T80L-77030-A

To service the 1-2 or 2-3 accumulators or the overdrive or reverse servo assemblies use the following procedure:

#### Removal

1. Remove the main control valve body (7A100) as described. This illustration shows the position of the overdrive servo, the reverse band servo piston and rod (7D189), 2-3 accumulator piston (7F251) and the 1-2 accumulator piston.

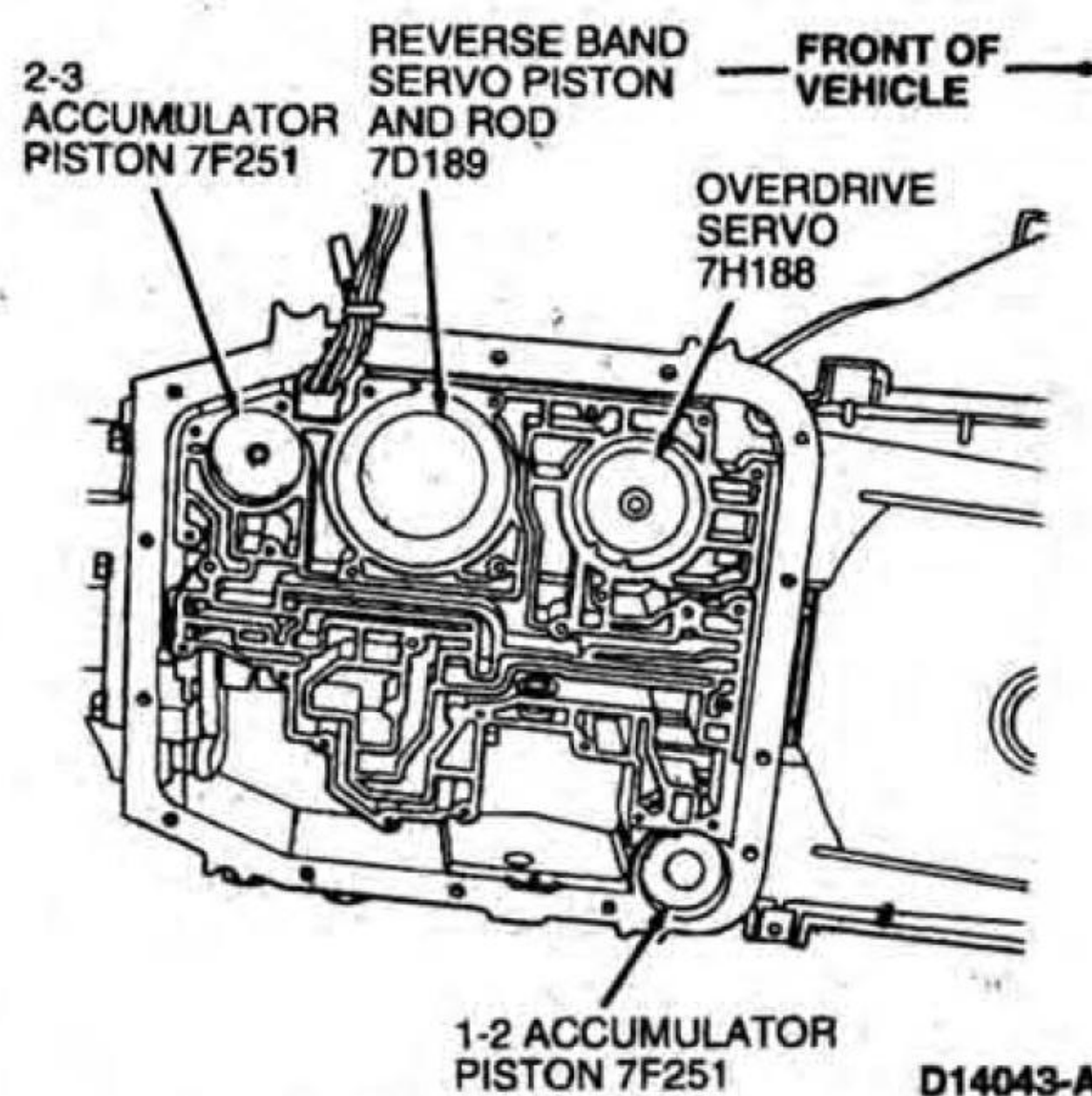

2. Remove the 2-3 accumulator spring retainer.

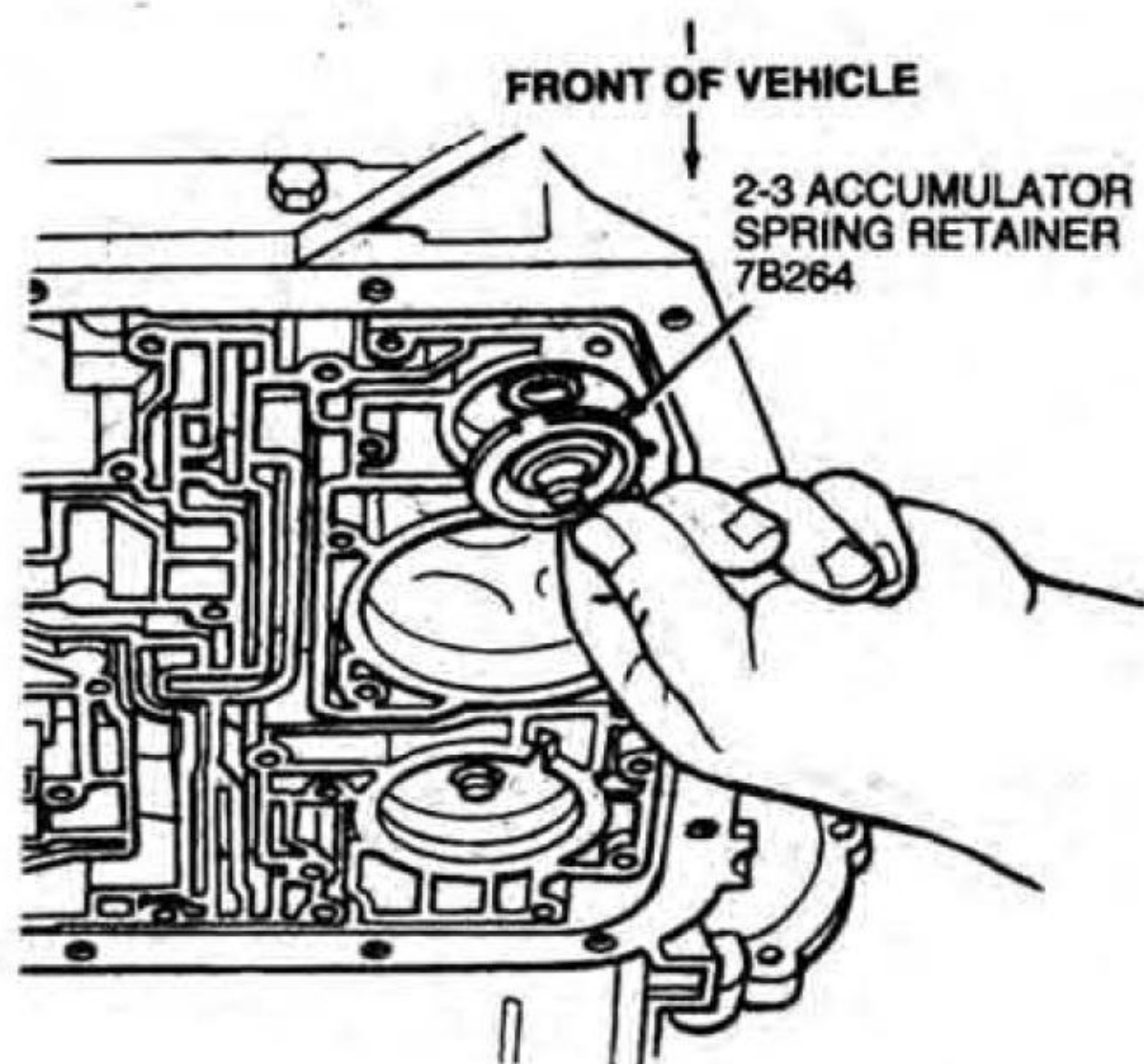

**IN-VEHICLE SERVICE (Continued)**

3. Remove 2-3 accumulator piston.

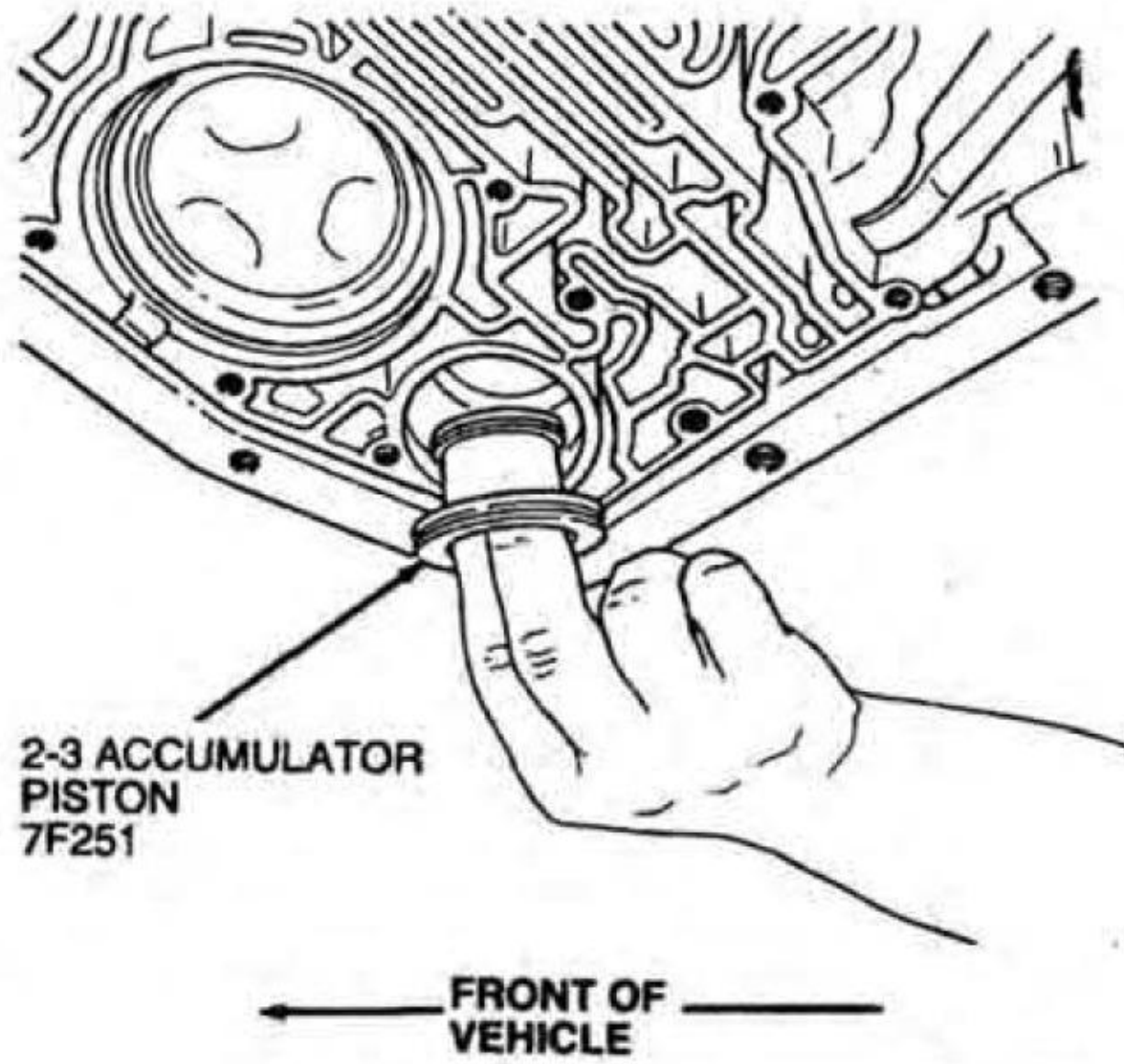

D14041-A

**Overdrive Servo**

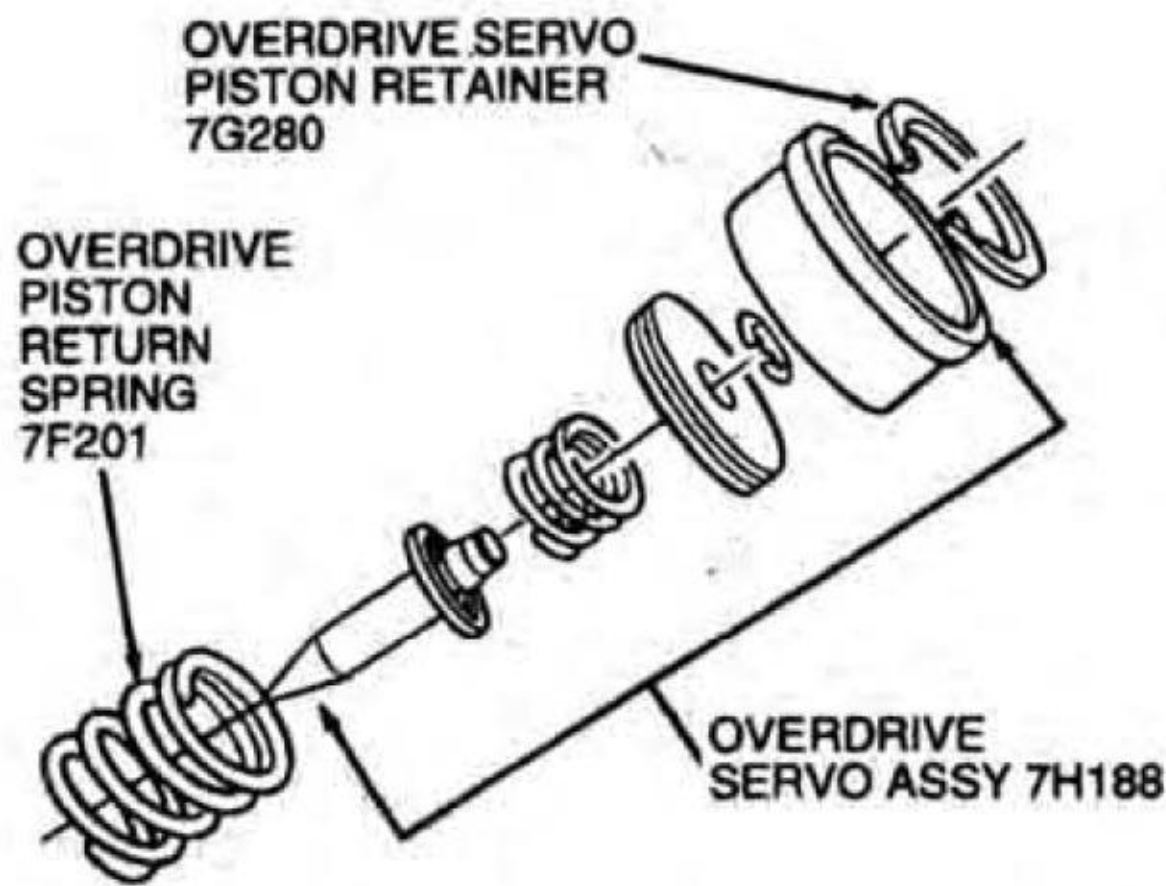

D11503-D

4. **NOTE:** If tool is not available, extreme care must be taken. Spring pressure will force overdrive servo piston (7F200) assembly out of case (7005). Case bore damage may result from trying to pry on overdrive servo piston retainer (7G280).

Use Servo Piston Remover / Replacer T92P-70023-A to compress the overdrive servo piston return spring (7F201). Use snap-ring pliers to remove retainer ring.

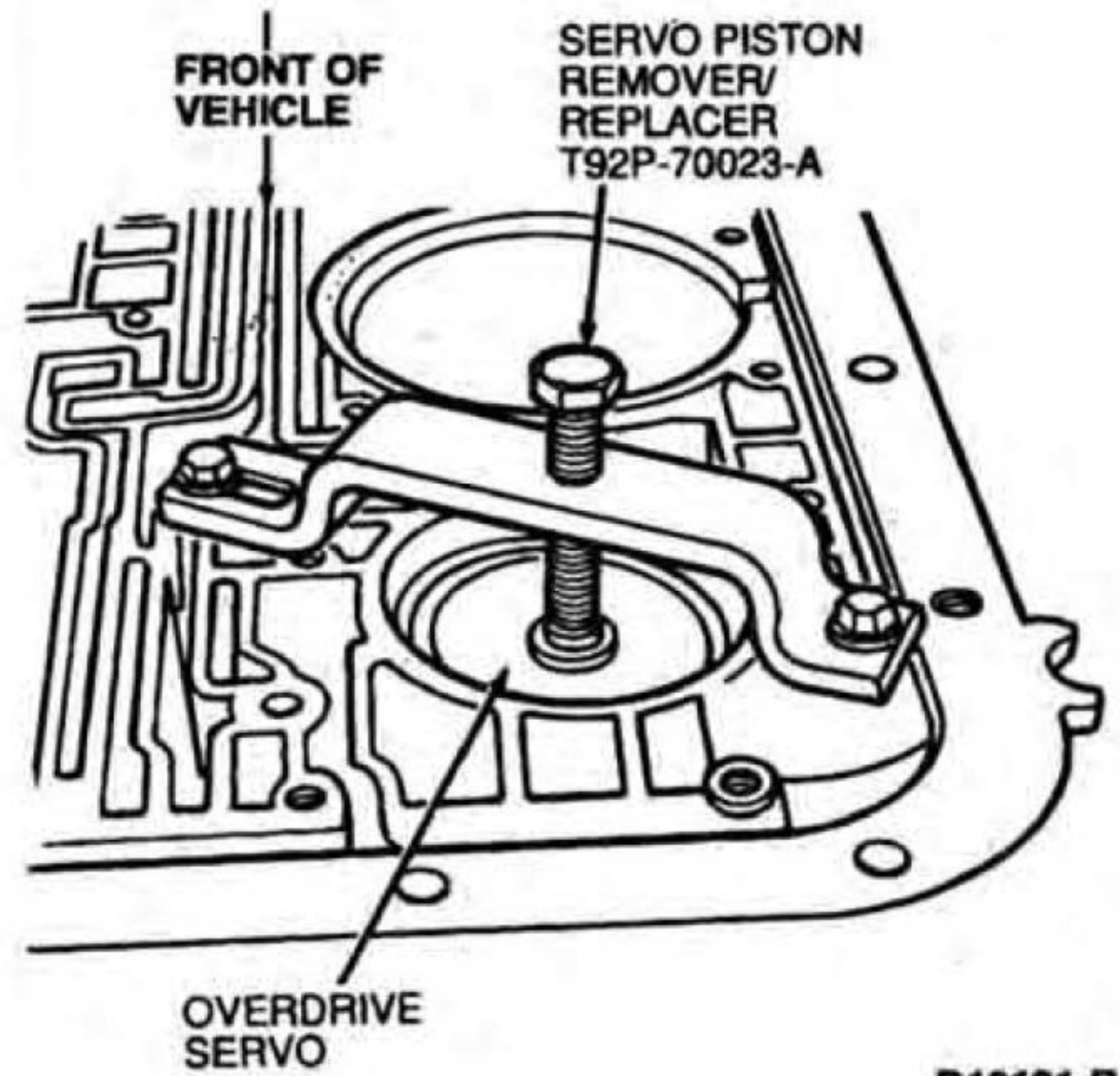

D10121-B

5. Remove piston assembly. Remove overdrive servo piston return spring.

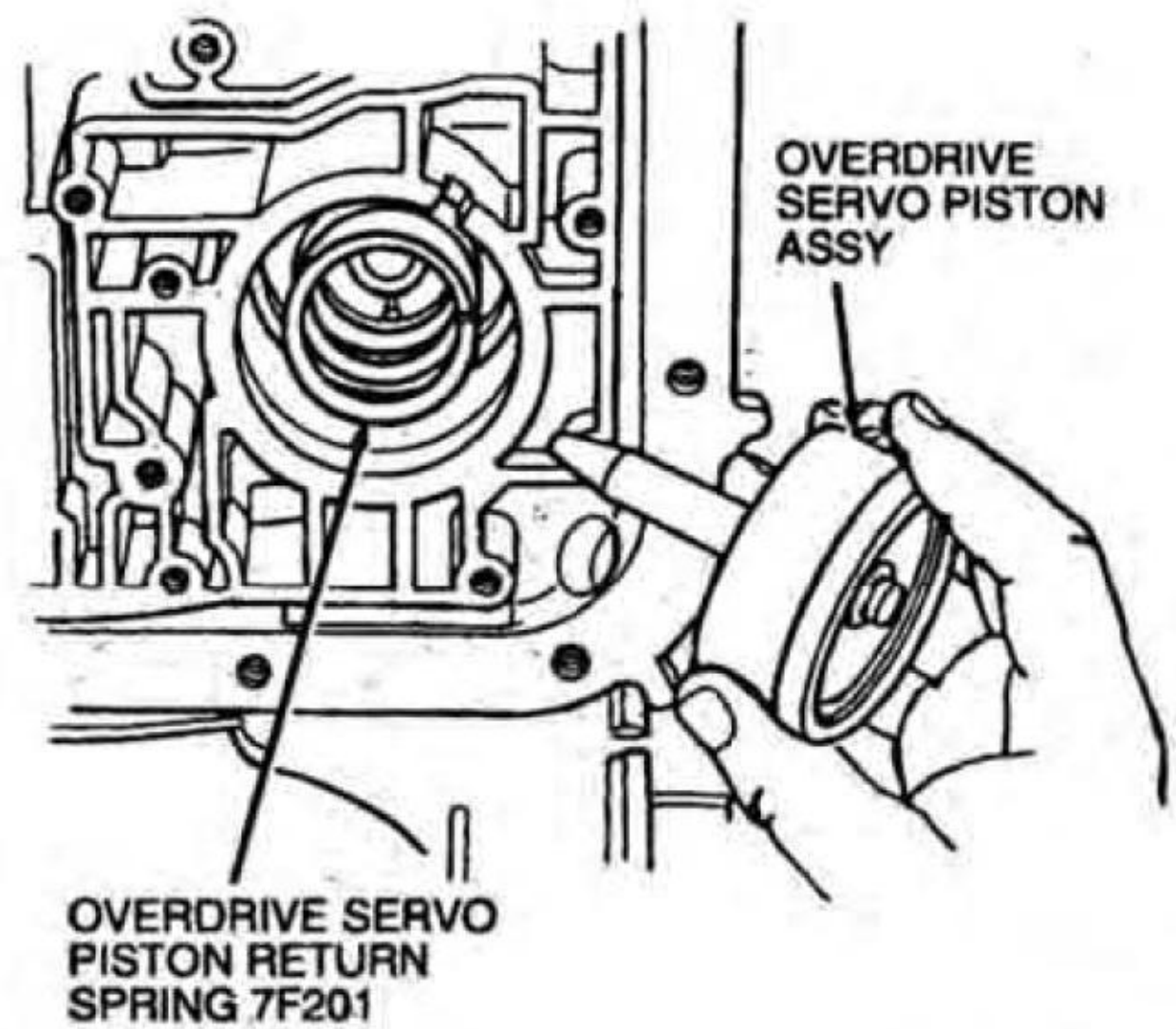

D14040-A

## IN-VEHICLE SERVICE (Continued)

## Reverse Band Servo

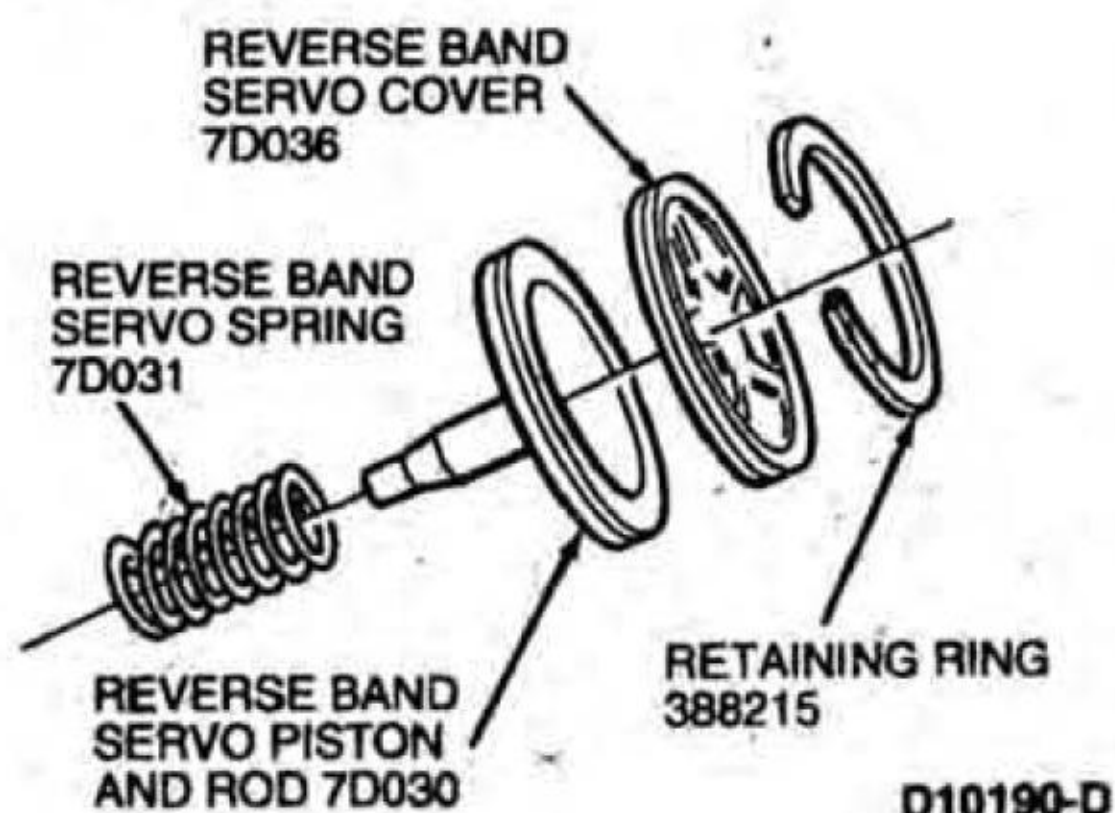

D10190-D

6. Use Servo Piston Remover / Replacer T92P-70023-A to contact the reverse band servo cover (7D036) and compress return spring and remove accumulator piston retaining ring.
7. **NOTE:** The length of the rod attached to the piston is graded for three different lengths. Therefore, they should not be installed in any transmission other than the transmission from which they were removed.

Remove reverse band servo cover, reverse band servo piston and rod and reverse band servo spring (7D031).

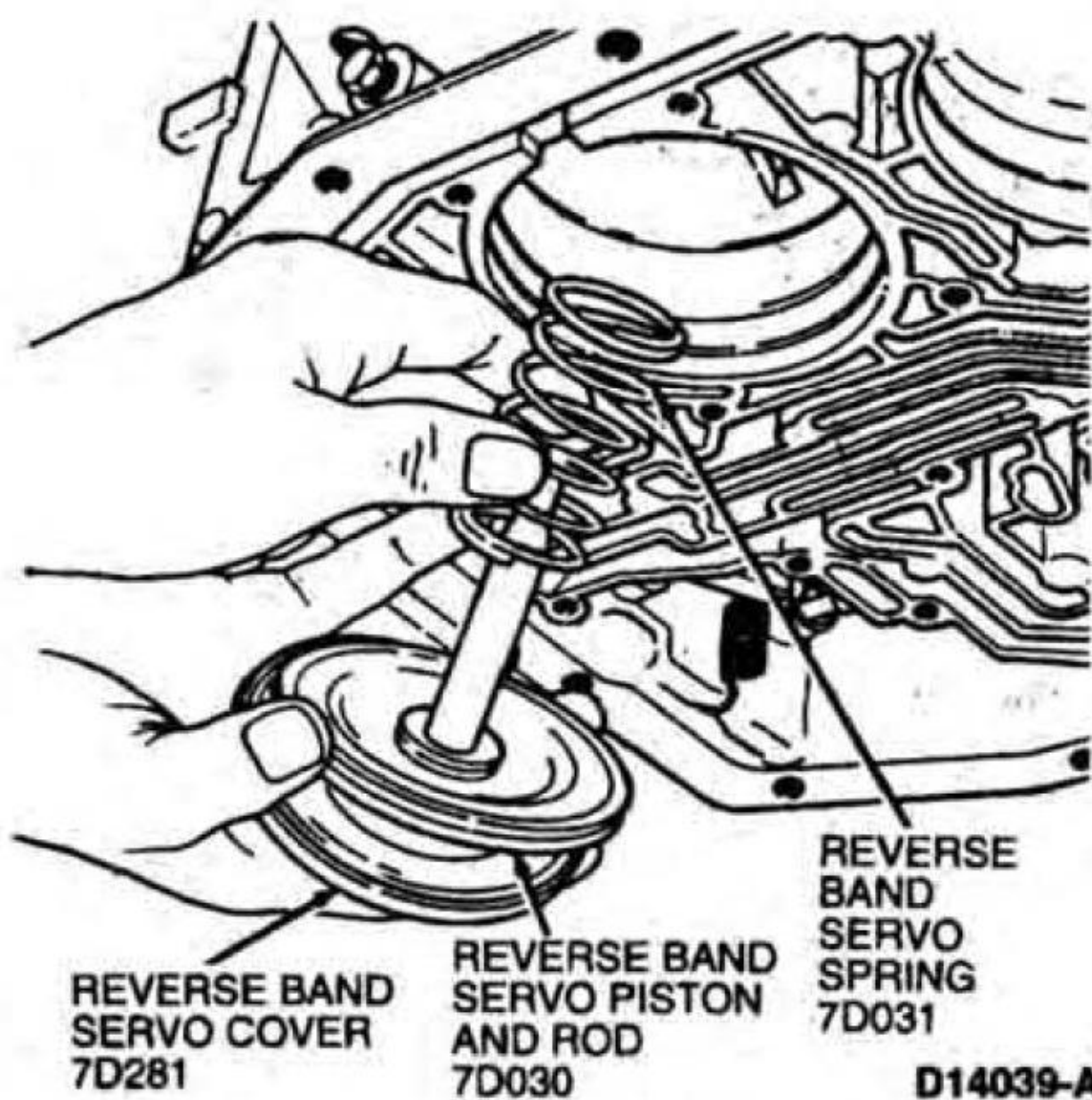

D14039-A

8. Apply downward pressure on 1-2 accumulator cover using Servo Piston Remover / Replacer T92P-70023-A. Using snap-ring pliers, remove 1-2 accumulator piston retaining ring.

## 1-2 Accumulator Cover

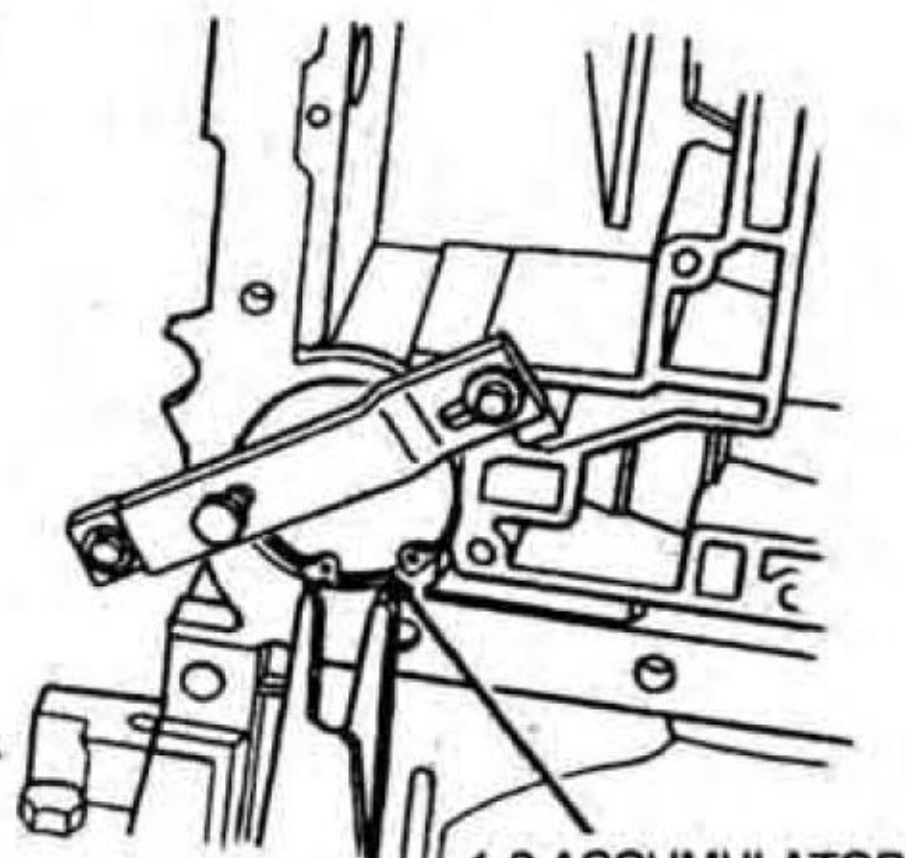

1-2 ACCUMULATOR  
PISTON RETAINING  
RING 97632

D14038-A

## 1-2 Accumulator

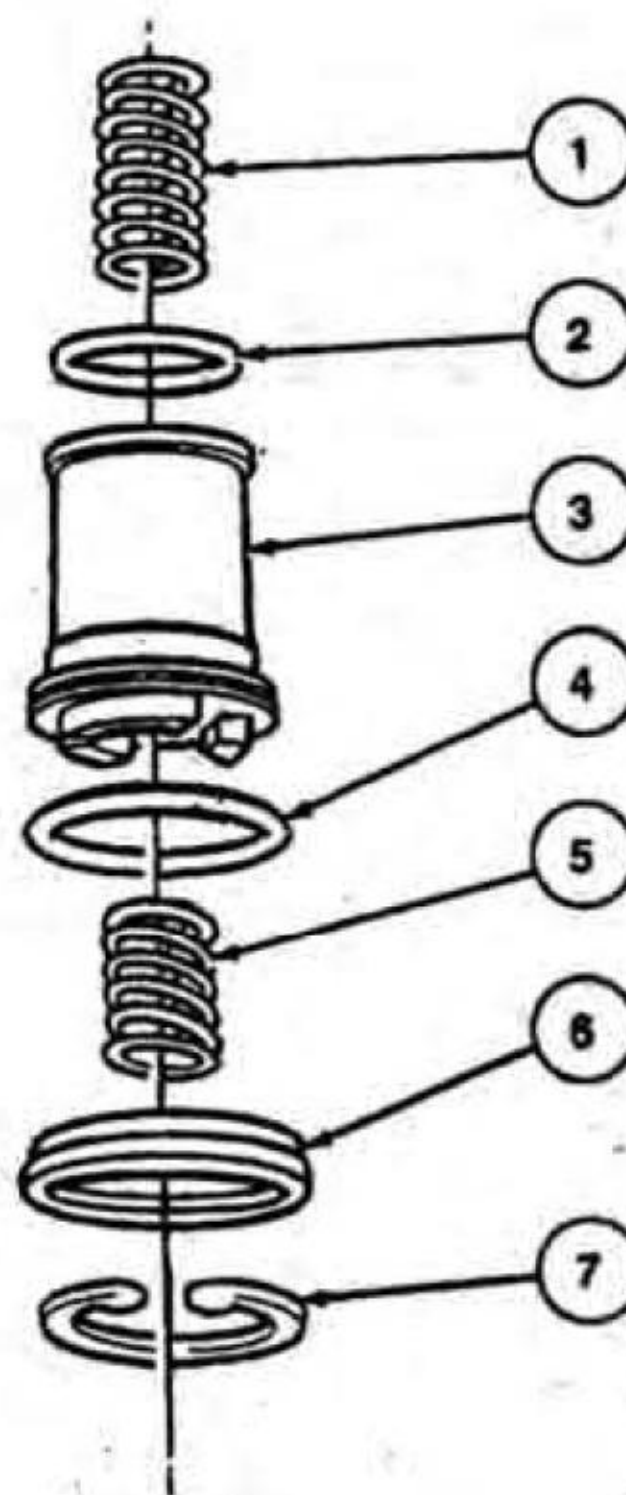

D10175-B

Item	Part Number	Description
1	7F284	1-2 Accumulator Spring
2	7F248	Accumulator Piston Seal
3	7F251	Accumulator Piston
4	7F249	Lower Accumulator Seal
5	7G267	1-2 Accumulator Spring
6	7G300	Cover and Seal Assembly
7	7384	Accumulator Piston Retaining Ring

## IN-VEHICLE SERVICE (Continued)

9. **NOTE:** Carefully note the location of the 1-2 accumulator spring and assemble in the same positions. Some models may use two 1-2 accumulator springs. The accumulator piston may also vary with applications.

Remove accumulator piston and 1-2 accumulator spring.

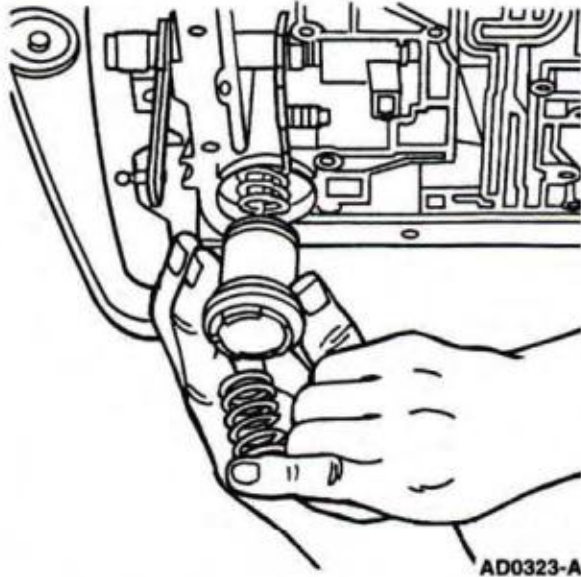

### Installation

1. **NOTE:** This is not an ordinary installation procedure nor does it compensate for band wear. Install reverse band servo spring, reverse band servo piston and rod. When piston and rod assembly replacement becomes necessary, or when the reverse band has been replaced, determine the correct length of the reverse servo piston and rod, proceed as follows:
- Lubricate the reverse piston seal to facilitate assembly and to prevent damage to the seal.
  - Install the reverse servo piston and return spring. Do not install the piston cover or retaining ring.
  - Install Servo Piston Selection Tool T80L-77030-A. Tighten the band apply bolt on Servo Piston Selection Tool T80L-77030-A to 5.6 N·m (49 lb-in).

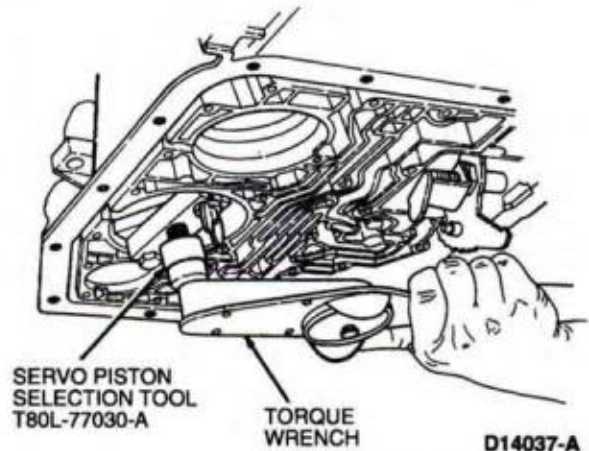

- d. Attach Dial Indicator with Bracketry TOOL-4201-C or equivalent and position the indicator stem on the flat portion of the piston. Zero the dial indicator.

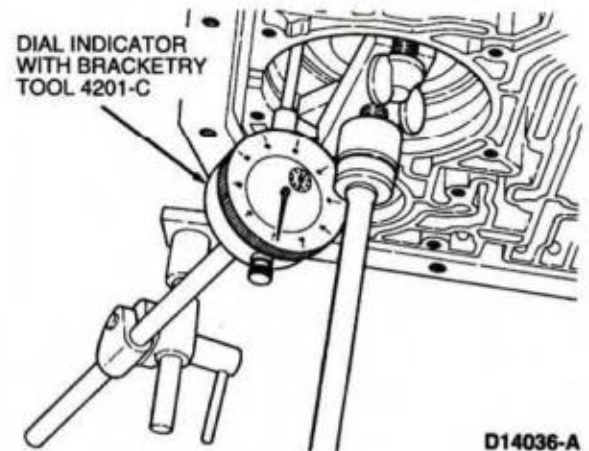

- Thread the bolt out of the selector tool until the piston stops against the bottom of the tool.
  - Read the amount of piston travel on the dial indicator.
- If the travel is 2.845-6.020 mm (0.112-0.237 inch), the piston length is within specification.
  - If the travel is not within specification, selective pistons are available in the following lengths:

ID

74.56 mm (2.936 inch) 1 groove

75.92 mm (2.989 inch) 2 grooves

77.29 mm (3.043 inch) 3 groove

Length of rod measured from piston surface to end of rod.

Select the proper rod to bring the servo piston travel within specification.

## IN-VEHICLE SERVICE (Continued)

- g. Lubricate the cover seal to facilitate assembly and to prevent damage to the seal.
  - h. Remove the servo selection tool and dial indicator.
2. Install Servo Piston Remover / Replacer T92P-70023-A to transmission case.
  3. Tighten screw on Servo Piston Remover / Replacer T92P-70023-A to allow enough clearance to install retaining ring.
  4. **CAUTION: Make sure reverse servo retaining ring is completely seated before removing tool.**  
Install reverse servo retaining ring and remove tool.

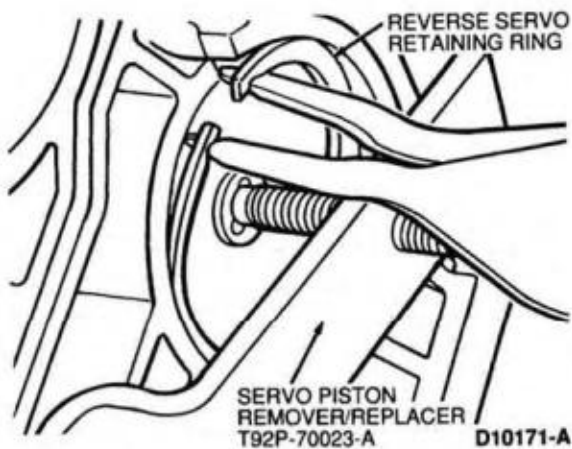

5. Install overdrive servo piston return spring and overdrive servo piston assembly. Verify tip of piston assembly engages the pocket of overdrive band. Using Servo Piston Remover / Replacer T92P-70023-A, install piston assembly into the case and compress overdrive servo piston return spring.

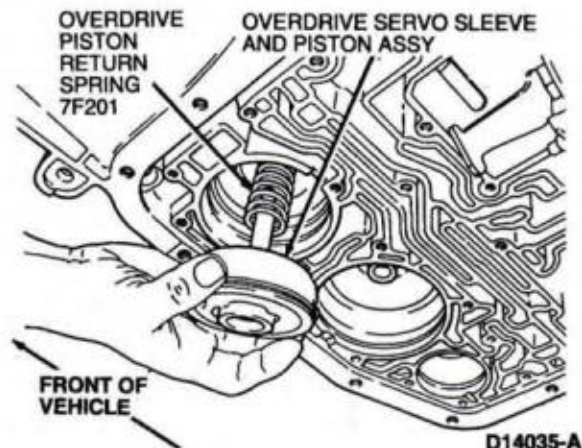

6. Tighten tool until piston is below retaining ring groove and install retaining ring, remove tool.
7. **NOTE: Retainer is secured by main control.**  
Install the components for 2-3 accumulator in the following order:

- upper accumulator seal (7F250)
- accumulator piston
- lower accumulator seal (7F249)
- accumulator piston spring (7F285)
- rear band servo spring retainer (7B264)

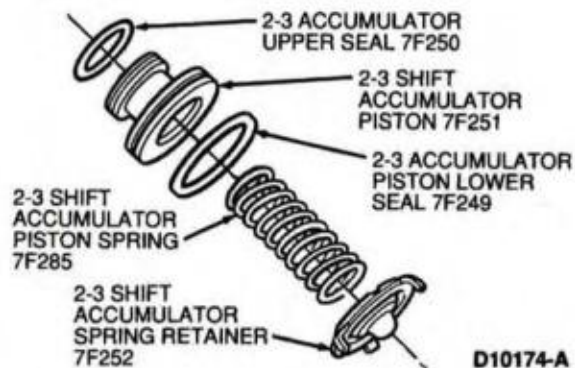

8. Assemble the components for 1-2 accumulator in the following order:
  - 1-2 accumulator spring
  - accumulator piston seal (7F248)
  - accumulator piston
  - lower accumulator seal

## IN-VEHICLE SERVICE (Continued)

- 1-2 accumulator spring
- cover and seal assembly
- accumulator piston retaining ring

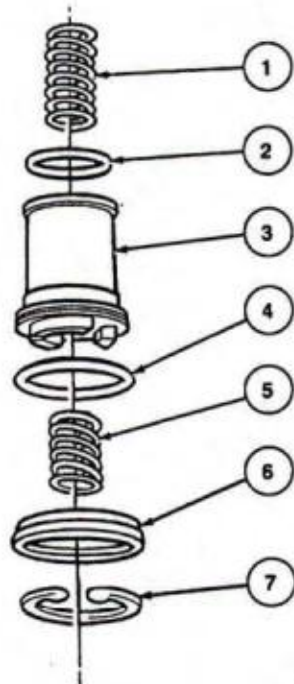

D10175-B

Item	Part Number	Description
1	7F284	1-2 Accumulator Spring
2	7F248	Accumulator Piston Seal
3	7F251	Accumulator Piston
4	7F249	Lower Accumulator Seal
5	7F284	1-2 Accumulator Spring
6	7G300	Cover and Seal Assy
7	7384	Accumulator Piston Retaining Ring

9. Install the 1-2 accumulator assembly and spring to case. Install cover and seal assembly. Install retaining ring.

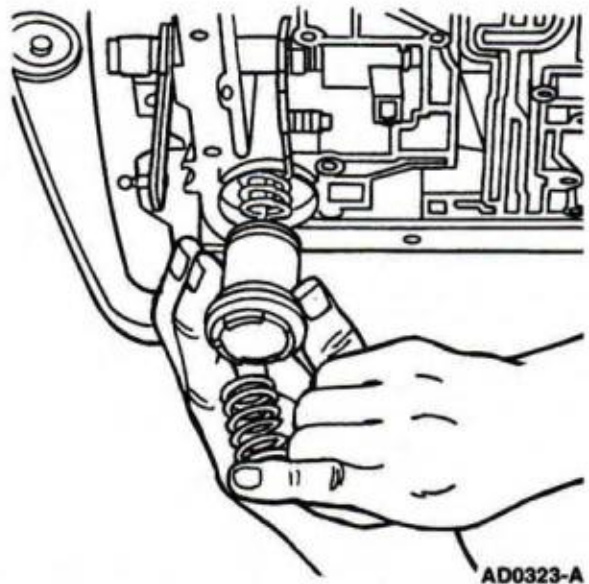

AD0323-A

10. Install main control valve body as described.  
11. Install fluid filter and grommet.

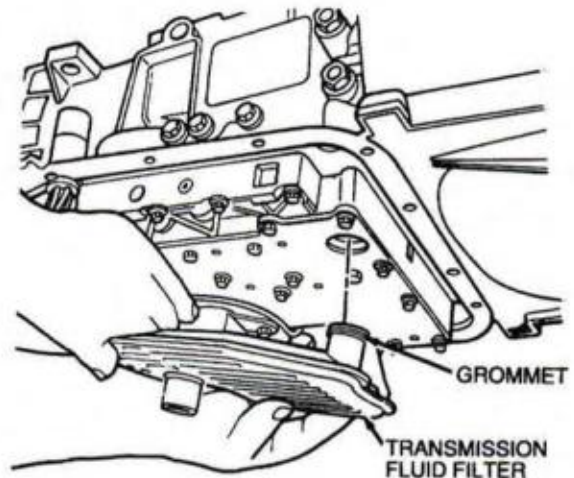

D14046-B

**IN-VEHICLE SERVICE (Continued)**

12. NOTE: Transmission pan-to-case gasket is reuseable if not damaged.  
Clean, inspect and install pan to case gasket and transmission pan. Tighten all bolts to 12-15 N·m (106-132 lb-in).

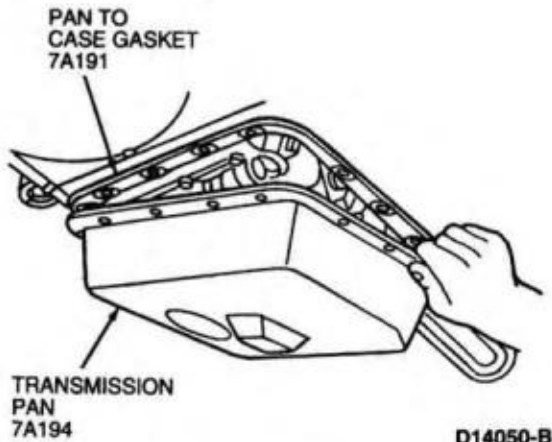

13. Install transmission shift linkage to manual control lever.
14. Pour 4.7 liters (5 quarts) of Motorcraft MERCON® Multi-Purpose (ATF) Transmission Fluid XT-2-QDX or equivalent MERCON® approved fluid into fluid filler tube.
15. Reconnect battery ground cable (14301). Refer to Section 14-01.
16. Start the engine and add specified fluid as required to achieve the proper fluid level as described.
17. Check the transmission for leaks.

2. Raise vehicle on a hoist. Refer to Section 00-02.
3. Drain transmission fluid as described.
4. Remove 14 pan retaining bolts, transmission pan and pan to case gasket.
5. Disconnect transmission shift linkage from manual control lever by removing adjusting nut.

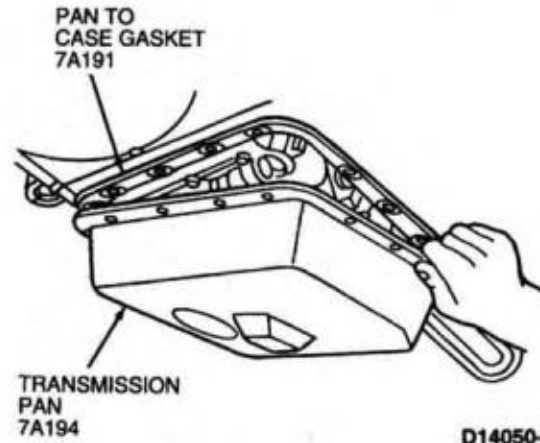

6. Remove pan magnet. Clean transmission pan and pan magnet.

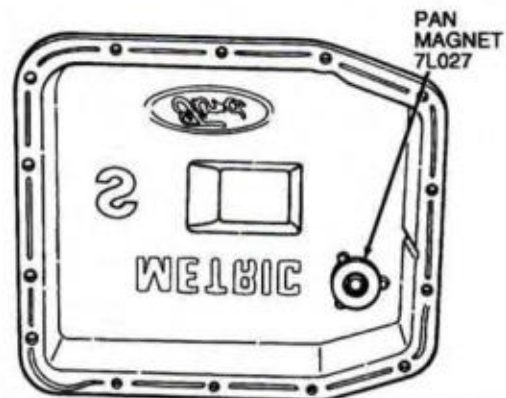
**Manual Control Lever Shaft Seal****SPECIAL SERVICE TOOL(S) REQUIRED**

Description	Tool Number
Shift Lever Seal Replacer	T74P-77498-A
Transmission Range (TR) Sensor Alignment Tool (MLPS Alignment Tool)	T93P-70010-A

**Removal**

1. Disconnect the battery ground cable (14301). Refer to Section 14-01.

## IN-VEHICLE SERVICE (Continued)

7. **CAUTION:** If installing a new filter, and grommet remains in the main control bore, carefully use a small screwdriver to remove the grommet. Use care not to damage the main control bore.

NOTE: If transmission is being serviced for a contamination-related failure, use a new filter and grommet. The filter may be reused if no excessive contamination is present.

Using both hands, remove filter by pulling downward.

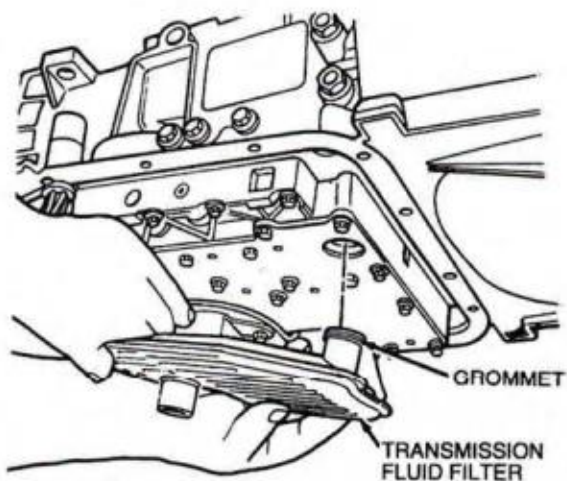

D14046-B

8. Remove two bolts retaining transmission range (TR) sensor to case (7005). Remove transmission range (TR) sensor from manual control lever (7A256).

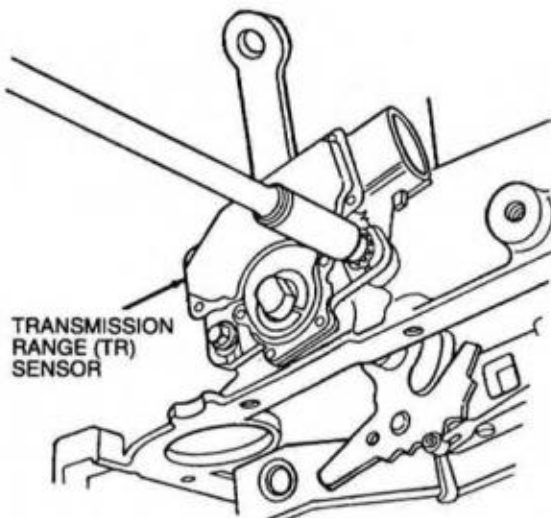

D14698-A

9. Remove one bolt retaining manual control valve detent lever spring (7A261) to the main control valve body (7A100).

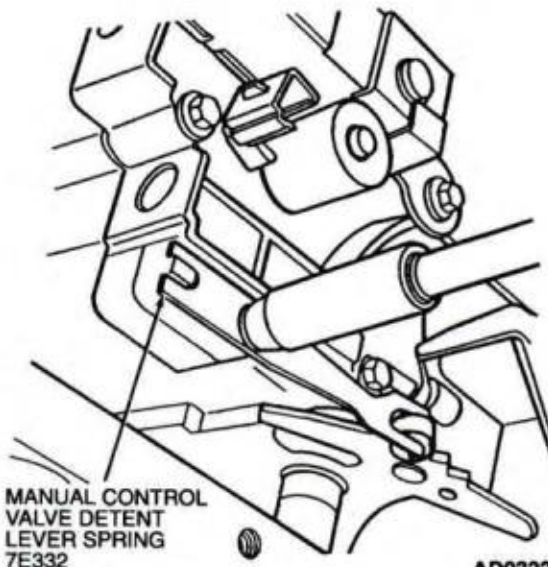

AD0322-A

10. NOTE: Use a shop cloth to protect pan-to-case surface.  
Remove manual lever shaft retaining pin (7B210).

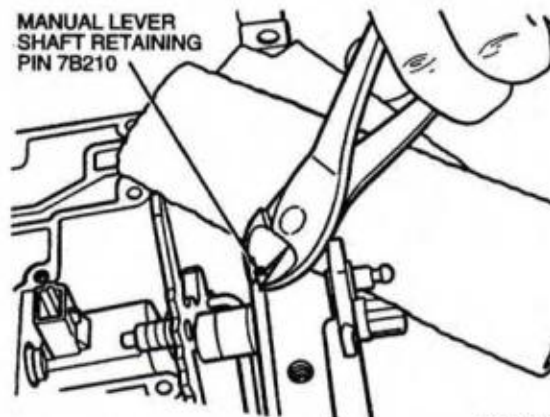

D8890-B

## IN-VEHICLE SERVICE (Continued)

11. Using a 13/16-inch open-end wrench on the inner nut and a 12 mm wrench on the manual control lever shaft flats, loosen the inner nut.

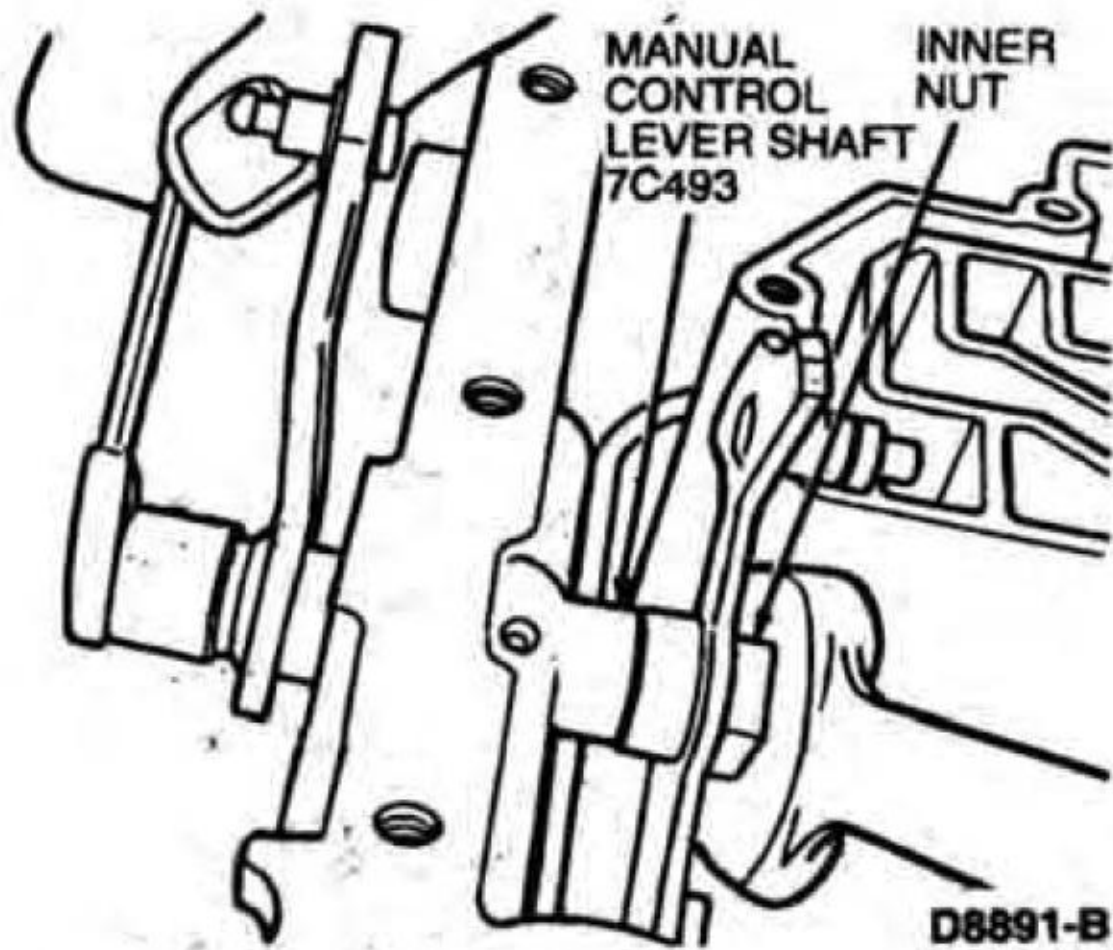

Slide manual control lever partially out of the case to complete removal of the inner nut from manual control lever. Remove manual control lever from case.

12. **NOTE:** Do not damage bore with the prying tool. Using a screwdriver on the manual control lever seal lower edge, carefully pry manual control lever seal out of case bore.

**Installation**

1. Install new manual control lever seal using Shift Lever Seal Replacer T74P-77498-A.

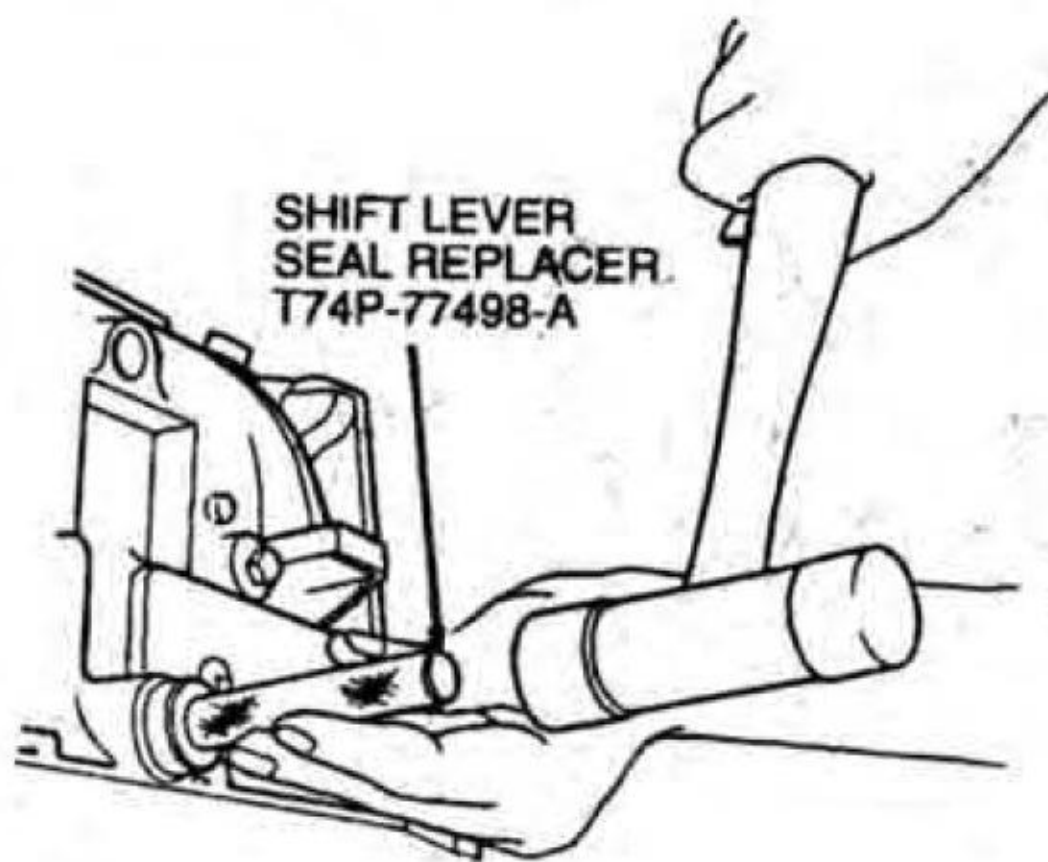

2. Position manual valve detent lever (7A115) and parking lever actuating rod (7A232) into case. Parking lever actuating rod must be positioned over parking pawl (7A441).

3. Slide manual control lever into case and position through detent. Install nut and tighten to 26-37 N-m (20-27 lb-ft).  
Install manual lever shaft retaining pin.
4. Install manual control valve detent lever spring and one bolt. Tighten to 11-15 N-m (98-132 lb-in).

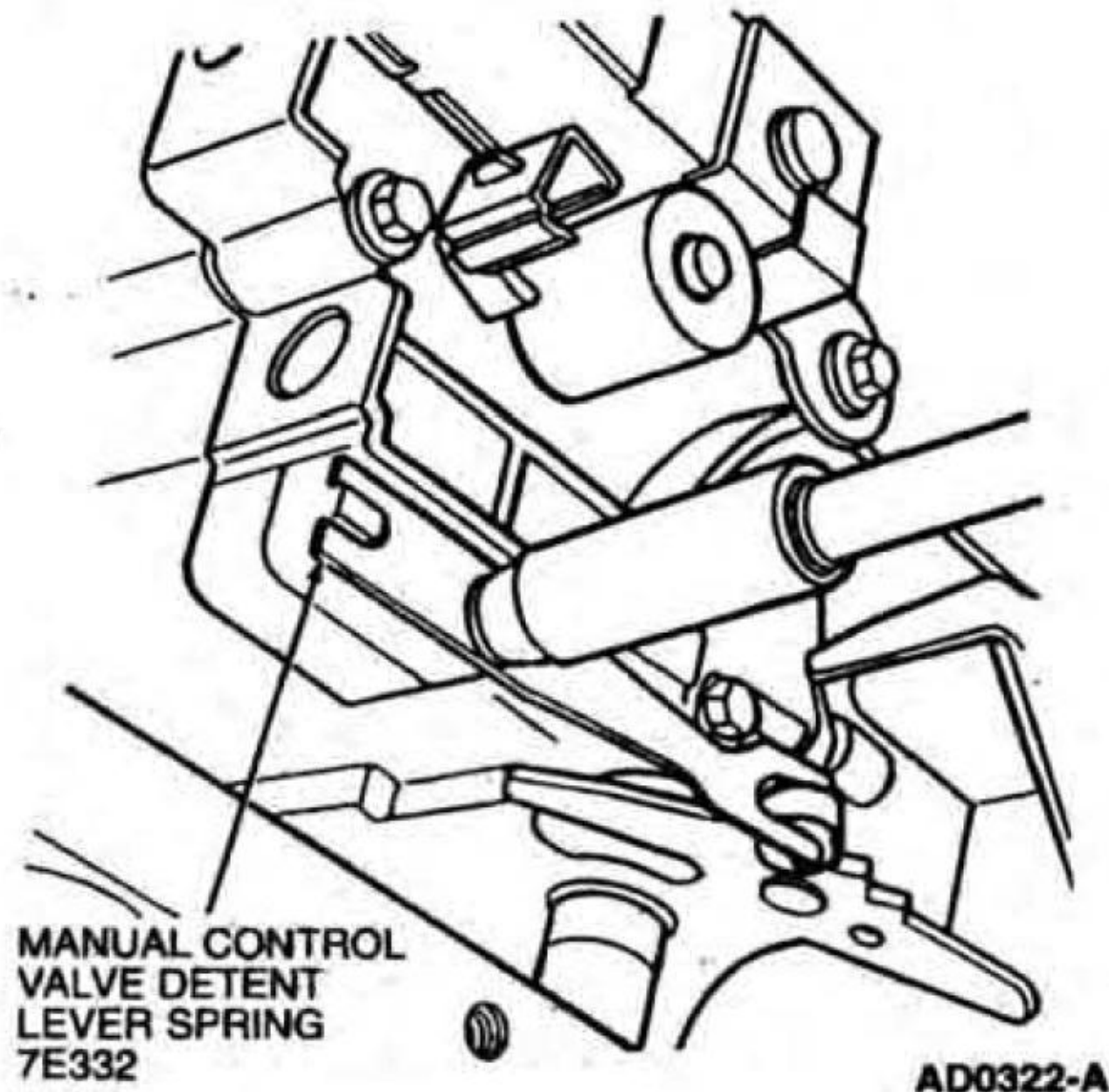

5. Install fluid filter and grommet.

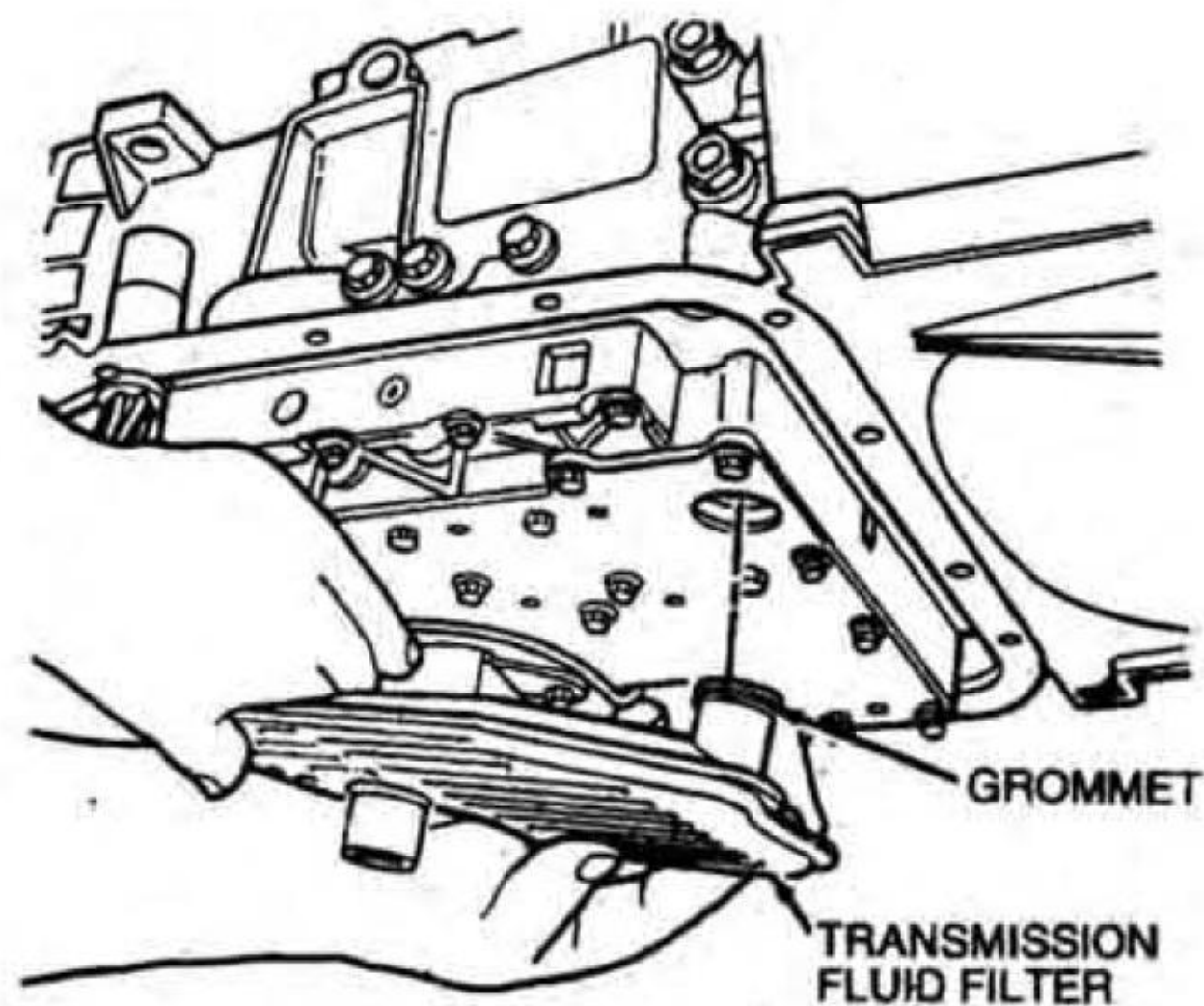

## IN-VEHICLE SERVICE (Continued)

6. Install TR sensor on manual control lever and two shims, then loosely install bolts.

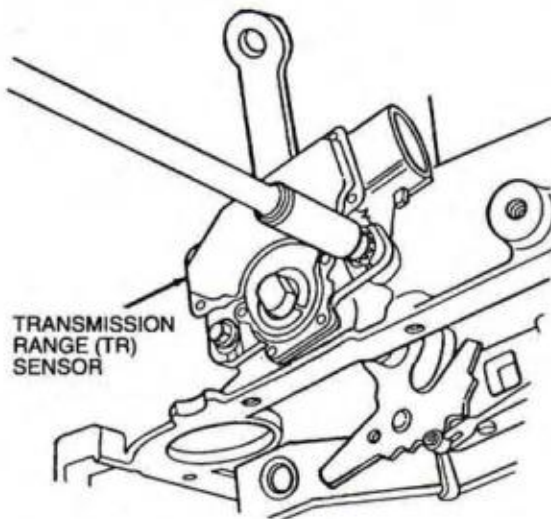

TRANSMISSION RANGE (TR) SENSOR

D14698-A

7. **NOTE:** PARK is the last detent when the manual control lever is full forward. Return two detents toward output shaft (7060) for NEUTRAL. Position manual control lever in NEUTRAL.
8. Insert Transmission Range (TR) Sensor (MLPS) Alignment Tool T93P-70010-A into slots. Align all three slots on TR sensor with three tabs on tool.

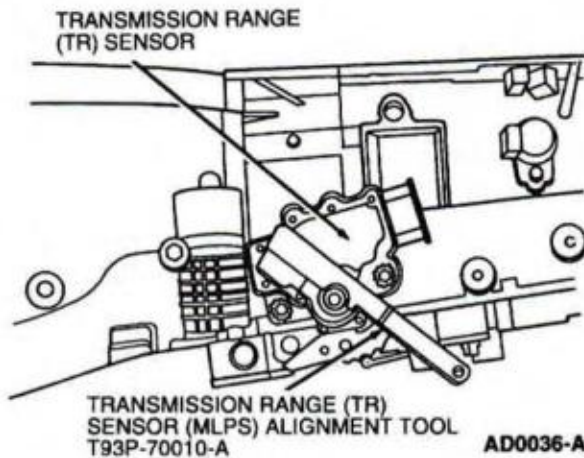

TRANSMISSION RANGE (TR) SENSOR

TRANSMISSION RANGE (TR) SENSOR (MLPS) ALIGNMENT TOOL T93P-70010-A

AD0036-A

9. Tighten TR sensor bolts to 7-10 N·m (62-88 lb-in).
10. **NOTE:** Transmission pan-to-case gasket is reuseable if not damaged. Clean, inspect and install pan to case gasket and transmission pan. Tighten all bolts to 12-15 N·m (106-132 lb-in).

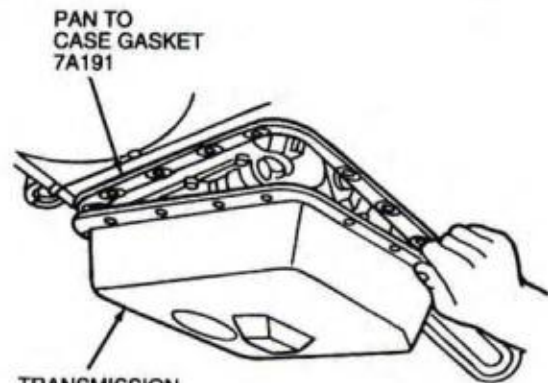

PAN TO CASE GASKET 7A191

TRANSMISSION PAN 7A194

D14050-B

11. Install transmission linkage to manual control lever.
12. Pour 4.7 liters (5 quarts) of Motorcraft MERCON® Multi-Purpose (ATF) Transmission Fluid XT-2-QDX or equivalent MERCON® approved fluid into fluid filler tube.
13. Reconnect battery ground cable. Refer to Section 14-01.
14. Start the engine and add specified fluid as required to achieve the proper fluid level as described.
15. Check the transmission for leaks.

### Fluid Cooler Tubes

When one or more of the cooler inlet tube and cooler tube must be replaced, each replacement tube must be fabricated from the same size steel tubing as the original line.

1. Using the old tube as a guide, bend the new tube as required. Add the necessary fittings and install the tube.
2. Tighten cooler tube-to-case fittings to 20-26 N·m (15-19 lb-ft).
3. Tighten cooler tube fittings to 24-31 N·m (18-22 lb-ft).
4. After the fittings have been tightened, add specified fluid as necessary and check for fluid leaks.

### Transmission Range (TR) Sensor

#### SPECIAL SERVICE TOOL(S) REQUIRED

Description	Tool Number
Transmission Range (TR) Sensor (MLPS) Alignment Tool	T93P-70010-A

**IN-VEHICLE SERVICE (Continued)****Removal**

1. Disconnect battery ground cable (14301). Refer to Section 14-01.
2. Raise vehicle on hoist. Refer to Section 00-02.
3. Disconnect electrical harness from transmission range (TR) sensor.
4. Remove two retaining bolts.
5. Remove transmission range (TR) sensor.

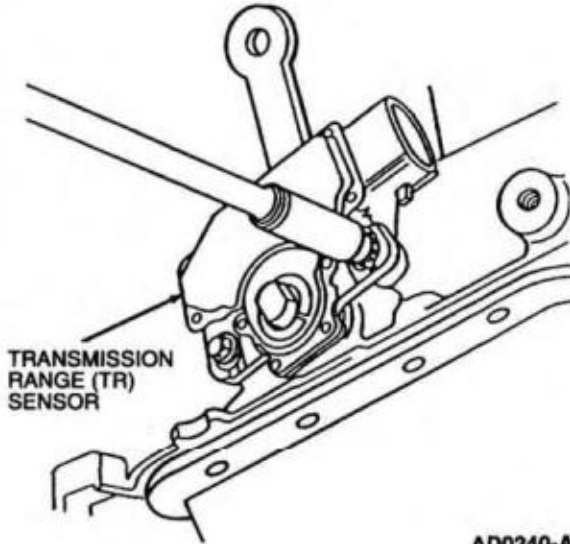

AD0240-A

**Installation**

1. Make sure manual control lever (7A256) is in the NEUTRAL position.
2. Install transmission range (TR) sensor and loosely install two retaining bolts.
3. Align TR sensor slots using Transmission Range (TR) Sensor (MLPS) Alignment Tool T93P-70010-A.

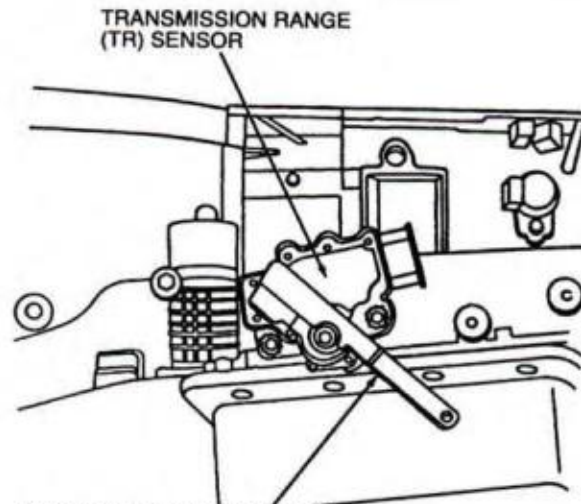
TRANSMISSION RANGE (TR)  
SENSOR (MLPS) ALIGNMENT TOOL  
T93P-70010-A

AD0241-A

4. Tighten retaining bolts to 7-10 N·m (62-88 lb-in) and remove tool.
5. Connect electrical harness to transmission range (TR) sensor.
6. Lower the vehicle.
7. Connect battery ground cable. Refer to Section 14-01.
8. Check for proper operation with parking brake control (2780) engaged. The engine should start only in PARK or NEUTRAL.

**REMOVAL****Transmission****SPECIAL SERVICE TOOL(S) REQUIRED**

Description	Tool Number
Extension Housing Seal Replacer	T61L-7657-B
Torque Converter Holding Tool	T97T-7902-A

**NOTE:** After transmission is removed for a major overhaul, it is important to completely clean all transmission components, including torque converter (7902), transmission cooler, cooler inlet tube, main control valve body (7A100), clutches and all coasting booster valve shuttle balls (7E195) after any transmission service that generates contamination. These contaminants are a major cause for recurring transmission concerns and must be removed from the system before the transmission is returned to service.

The cleaning of debris from the direct clutch check ball is often omitted. This omission can lead to a repeat servicing of the transmission.

Cleaning and flushing procedures for transmission components, including the direct clutch check ball, as described under Cleaning and Inspection.

## REMOVAL (Continued)

## Removal

1. Disconnect the battery ground cable (14301). Refer to Section 14-01.
2. Raise vehicle on a hoist. Refer to Section 00-02.
3. Drain transmission fluid as described.
4. Remove exhaust system as necessary for transmission removal. Refer to Section 09-00.
5. Remove the converter access cover and adapter plate bolts from the engine oil pan (6675).
6. **CAUTION: Care should be taken not to damage cooler lines.**  
NOTE: Never rotate the crankshaft pulley (6312) in a counterclockwise direction (as viewed from the front).  
Remove the four flywheel-to-converter retaining nuts by placing a 22 mm socket and breaker bar on the crankshaft pulley retaining bolt. Rotate the crankshaft pulley clockwise (as viewed from the front) to gain access to each of the nuts.
7. Remove driveshaft. Refer to Section 05-01.
8. Disconnect and remove the vehicle speed sensor (VSS)(9E731) from the extension housing (7A039).
9. Place a drain pan under the torque converter. With the wrench on the crankshaft pulley retaining bolt, turn the torque converter to gain access to the converter housing access plug (7N171) and remove. After the fluid has been drained, install the converter housing access plug.
10. Carefully disconnect shift cable from transmission manual control lever at transmission by removing adjusting nut.
11. Disconnect the transmission wiring harness connectors.
12. Remove starter-to-converter housing retaining bolts and position starter motor (11002) out of the way.
13. Position a transmission jack under the transmission and raise it slightly.
14. Remove the engine rear support-to-crossmember bolts.
15. Remove the crossmember-to-frame side support retaining bolts and remove the engine and transmission support insulator (6F063) and engine and transmission support (6F065) and engine damper mounting body bracket (6F067).
16. Lower the jack under the transmission and allow the transmission to hang.
17. Position a jack to the front of the engine and raise the engine to gain access to the two upper converter housing-to-engine retaining bolts.
18. Disconnect the cooler tubes at the transmission. Plug all openings to keep dirt out.
19. Remove the lower converter housing-to-engine retaining bolts.
20. Remove the transmission fluid filler tube.

21. Secure the transmission to the jack with a safety chain.
22. NOTE: If the transmission is to be removed for a period of time, support the engine with a safety stand and wood block.  
Remove the two upper converter housing-to-engine retaining bolts. Move the transmission to the rear so it disengages from the dowel pins and the torque converter is disengaged from the flywheel (6375).
23. Install Torque Converter Holding Tool T97T-7902-A to prevent torque converter from falling out. Lower the transmission from the vehicle.
24. Remove Torque Converter Holding Tool T97T-7902-A.
25. Remove torque converter from transmission.

## DISASSEMBLY

## Transmission

## SPECIAL SERVICE TOOL(S) REQUIRED

Description	Tool Number
Bench Mounted Holding Fixture	T67L-500-B
Servo Piston Remover / Replacer	T92P-70023-A
Seal Remover	T74P-7724B-A
Extension Housing Bushing Remover	T77L-7697-A
Impact Slide Hammer	T59L-100-B
Pump Puller Adapters	T89T-70010-A
Bearing Cup Puller	T77F-1102-A

NOTE: Before beginning Disassembly, perform / inspect the following:

- The transmission service area should be kept clean, well organized and supplied with clean, lint-free shop cloths.
- Thorough cleaning of the transmission exterior will reduce the possibility that damaging contaminants might enter the subassemblies during disassembly and assembly.
- If the transmission is being removed for major overhaul, it is important to completely clean all transmission components, including torque converter (7902), cooler, cooler inlet tubes, main control valve body (7A100), all clutches and all coasting booster valve shuttle balls (7E195) after any transmission servicing that generates contamination. These contaminants are a major cause for recurring transmission troubles and must be removed from the system before the transmission is returned to service. The cleaning of debris from the direct clutch check ball is often omitted. This omission can lead to a repeat servicing of the transmission.
- Debris that collects and builds up in the corners of the stamped clutches must be removed.

**DISASSEMBLY (Continued)**

- The pan magnet should be removed from transmission pan and wiped clean along with the transmission pan.
- Whenever a seal is removed from a piston, shaft or servo, note the type of seal and when applicable, the direction of the sealing lip.

**Disassembly**

1. Mount transmission in Bench Mounted Holding Fixture T57L-500-B.

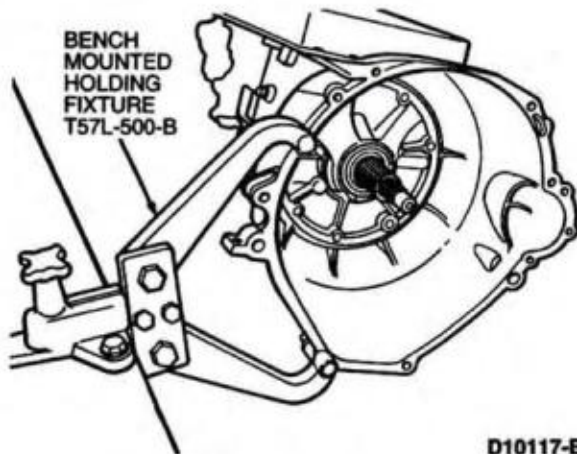

D10117-B

2. Remove 14 pan retaining bolts, transmission pan and pan-to-case gasket.

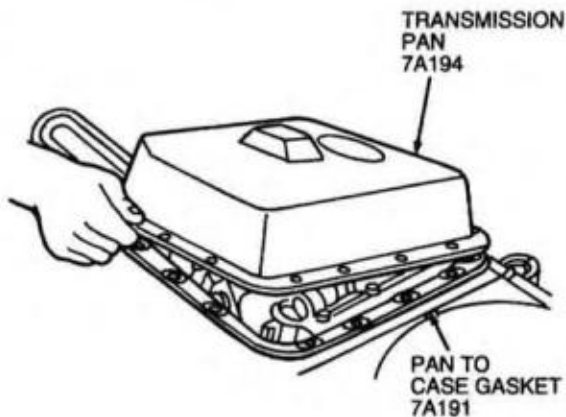

D10374-D

3. Remove pan magnet. Clean transmission pan and pan magnet.

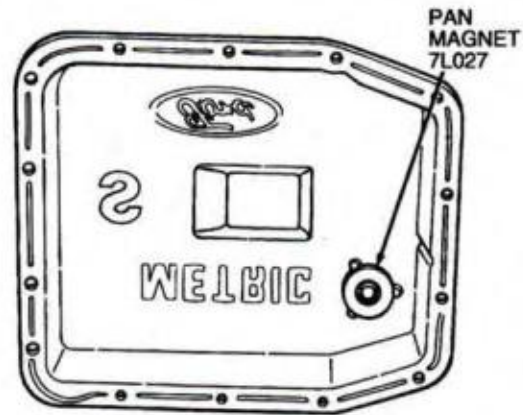

D10254-D

4. **CAUTION:** If installing a new filter, and grommet remains in the main control bore, carefully use a small screwdriver to remove the grommet. Use care not to damage the main control bore.

**NOTE:** If transmission is being serviced for a contamination-related failure, use a new filter and grommet. The filter may be reused if no excessive contamination is present.

Using both hands, remove filter by pulling upward.

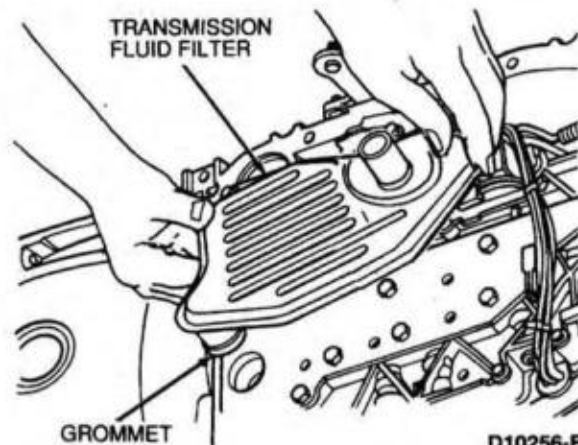

D10256-B

## DISASSEMBLY (Continued)

5. **CAUTION:** Do not pull on wires. This may damage wires or connectors and could result in a transmission concern. If required, carefully pry up on locking tab and disconnect the connector.

Grasp connector at each solenoid or sensor and pull straight out to disconnect.

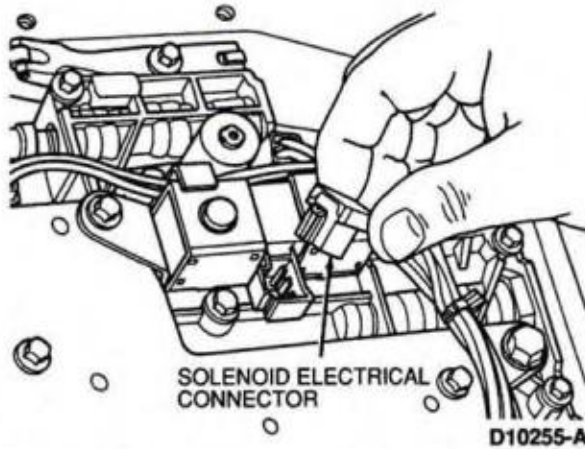

6. **NOTE:** Removal of the OSS at this time will prevent sensor damage when removing the output shaft (7060).  
Remove bolt retaining output shaft speed sensor (OSS) to case (7005) and remove OSS.

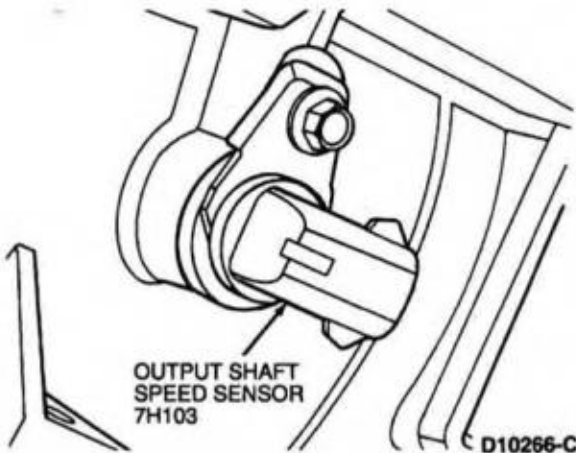

7. Remove two bolts retaining transmission range (TR) sensor to case. Remove transmission range (TR) sensor from manual control lever (7A256).

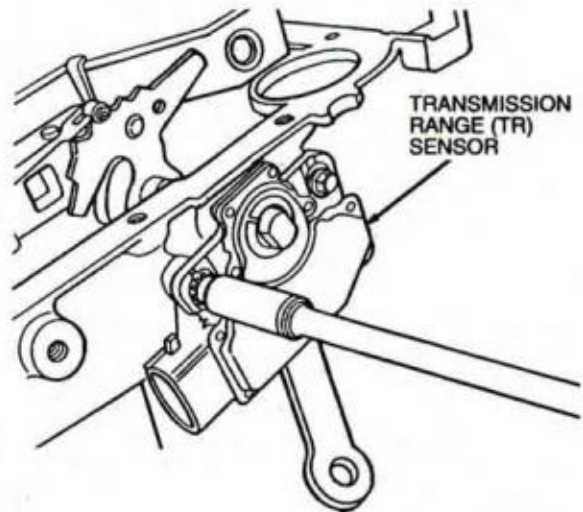

8. Remove one bolt retaining manual control valve detent lever spring (7A261) to the main control valve body.

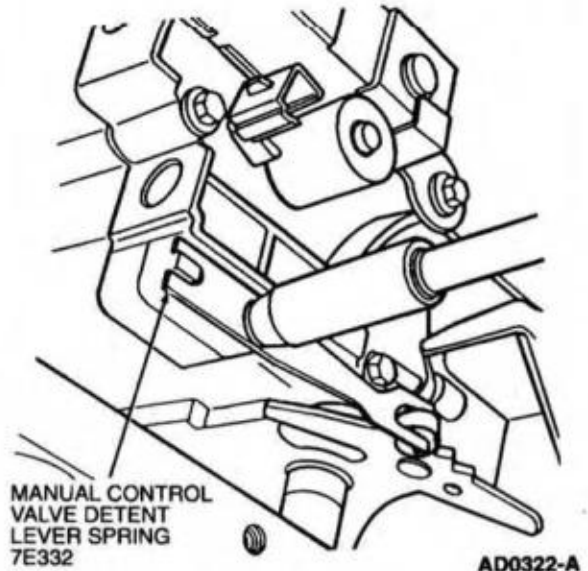

## DISASSEMBLY (Continued)

9. Remove remaining 24 valve body-to-case retaining bolts, the main control valve body and the valve-to-body gasket.

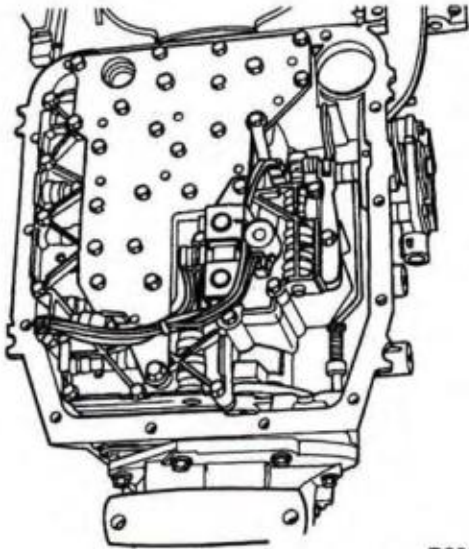

D8889-B

10. NOTE: Use a shop cloth to protect pan-to-case surface.  
Remove manual lever shaft retaining pin (7B210).

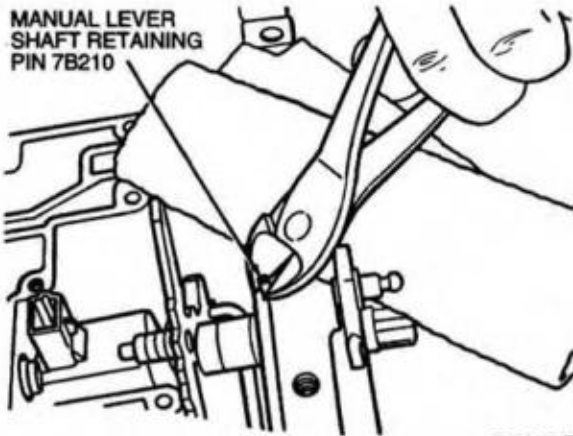

D8890-B

11. Using a 13/16-inch open-end wrench on the inner nut and a 12 mm wrench on the manual control lever shaft flats, loosen the inner nut.

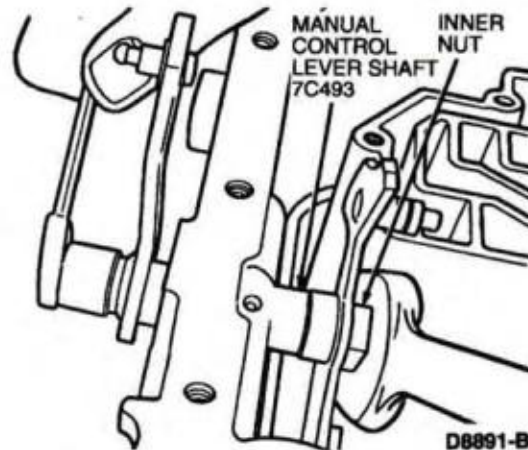

D8891-B

Slide manual control lever partially out of the case to complete removal of the inner nut from manual control lever.

12. NOTE: Do not damage bore with the prying tool.  
Using a screwdriver on the manual control lever seal lower edge, carefully pry manual control lever seal out of case bore.
13. Lift manual valve detent lever (7A115) and parking lever actuating rod (7A232) out of the case.

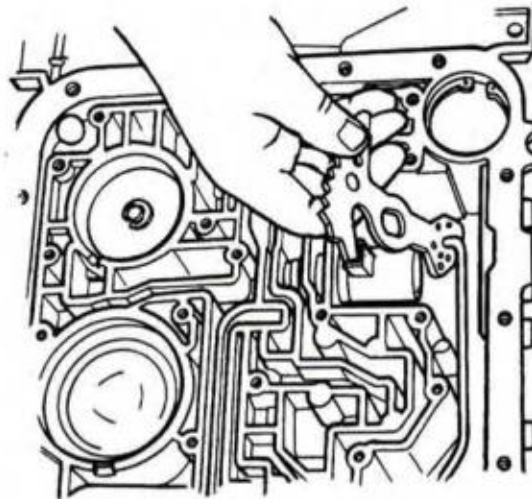

D10540-A

**DISASSEMBLY (Continued)**

- 14. Remove electronic pressure control (EPC) solenoid by sliding it out of the case bore.

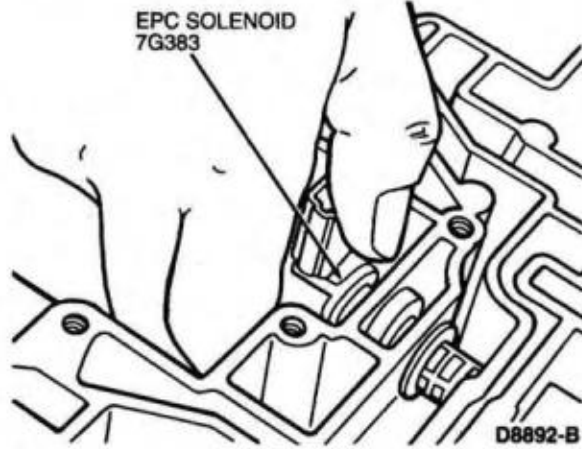

- 15. This illustration shows the position of the overdrive servo, the reverse band servo, 2-3 accumulator piston (7F251) and the 1-2 accumulator piston.

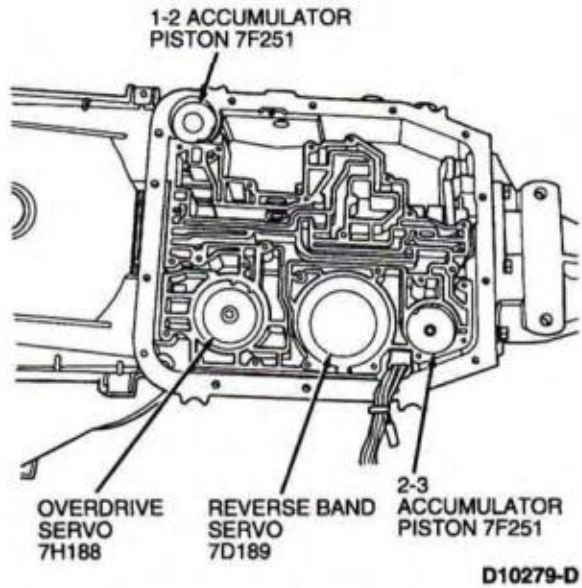

- 16. Remove the 2-3 accumulator spring retainer.

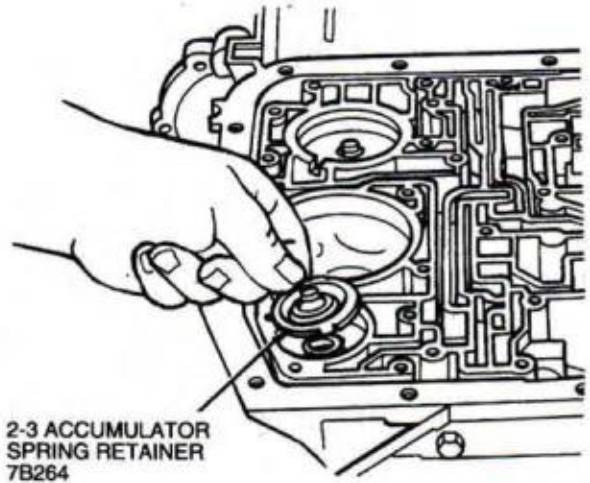

- 17. Remove 2-3 accumulator piston.

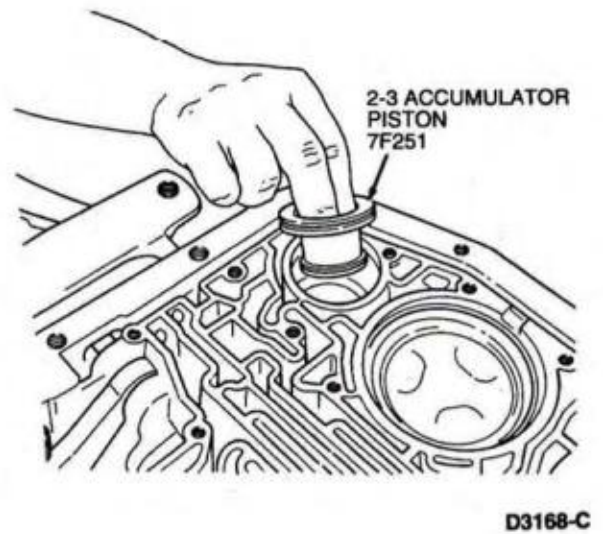

## DISASSEMBLY (Continued)

## Overdrive Servo

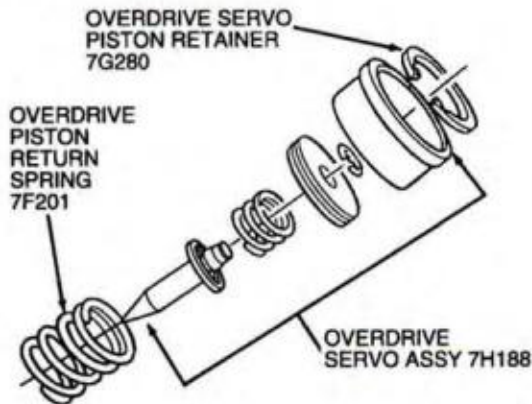

D11503-D

18. NOTE: If tool is not available, extreme care must be taken. Spring pressure will force overdrive servo piston (7F200) assembly out of case. Case bore damage may result from trying to pry on overdrive servo piston retainer (7G280).

Use Servo Piston Remover / Replacer T92P-70023-A to compress the overdrive servo piston return spring (7F201). Use snap-ring pliers to remove retainer ring.

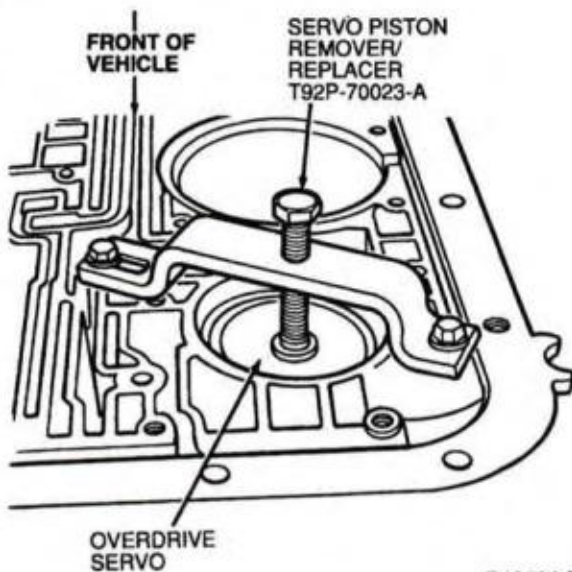

D10121-B

19. Remove piston assembly. Remove overdrive servo piston return spring.

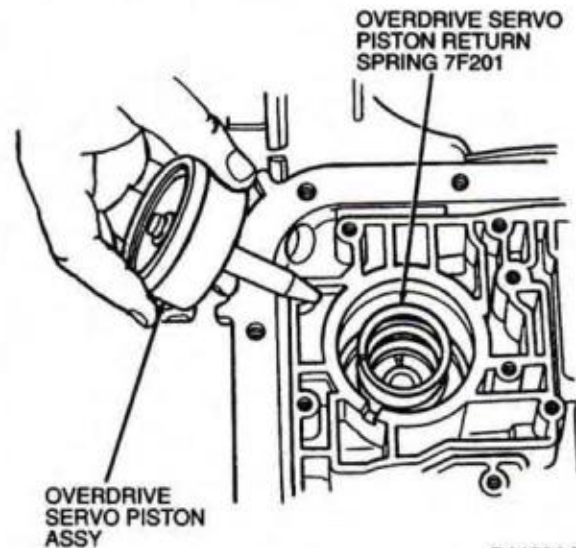

D11504-B

## Reverse Band Servo

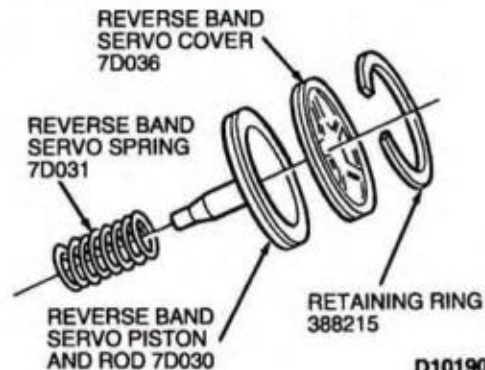

D10190-D

20. Use Servo Piston Remover / Replacer T92P-70023-A to contact the reverse band servo cover (7D036) and compress return spring and remove servo cover retaining ring.

**DISASSEMBLY (Continued)**

21. NOTE: The length of the rod attached to the piston is graded in three different lengths. Therefore, they should not be installed in any transmission other than the transmission from which they were removed.

Remove reverse band servo cover, reverse band servo piston and rod (7D189) and reverse band servo spring (7D031).

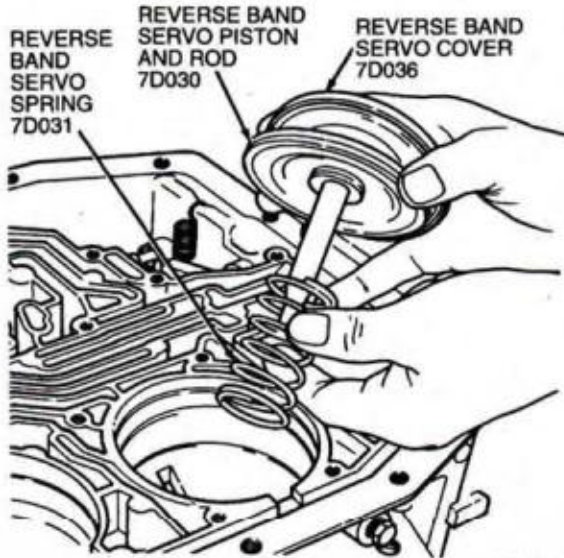

D5879-B

22. Apply downward pressure on 1-2 accumulator cover using Servo Piston Remover / Replacer T92P-70023-A. Using snap-ring pliers, remove 1-2 accumulator piston retaining ring (7384).

**1-2 Accumulator Cover**

1-2 ACCUMULATOR PISTON RETAINING RING 97632

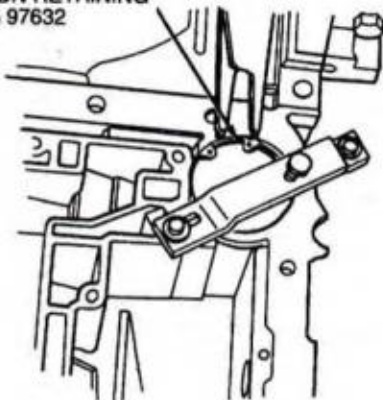

D10262-C

**1-2 Accumulator**

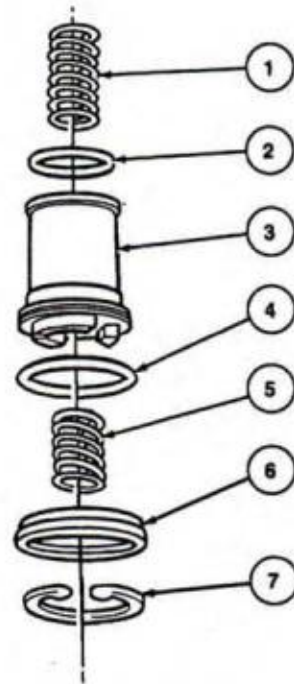

D10175-B

Item	Part Number	Description
1	7F284	1-2 Accumulator Spring
2	7F248	Accumulator Piston Seal
3	7F251	Accumulator Piston
4	7F249	Lower Accumulator Seal
5	7F284	1-2 Accumulator Spring
6	7G300	Cover and Seal Assembly
7	7384	Accumulator Piston Retaining Ring

## DISASSEMBLY (Continued)

23. Carefully note the location of the 1-2 accumulator springs and assemble in the same positions. Some models may use two 1-2 accumulator springs. The accumulator piston may also vary with applications. Remove accumulator piston and 1-2 accumulator springs.

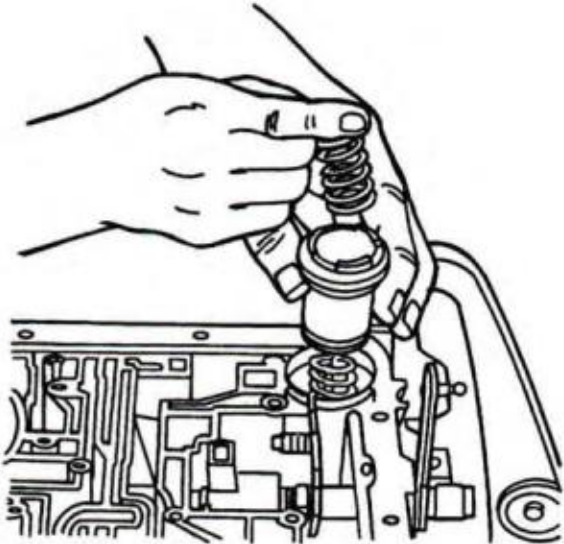

24. Remove fluid screen from case.

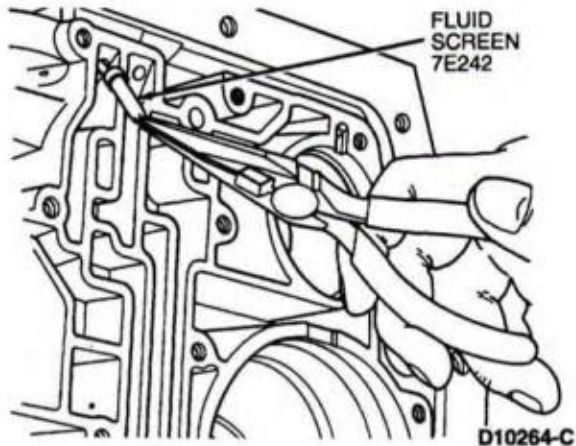

25. Remove extension housing seal using Seal Remover T74P-77248-A. Make sure seal remover lips are firmly seated under the flange on the extension housing seal.

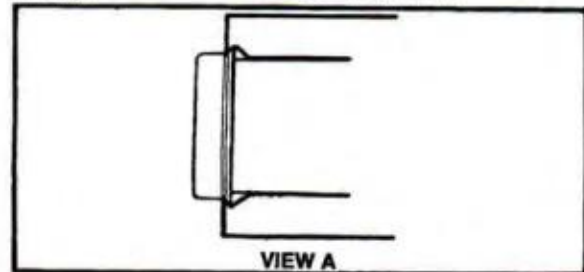
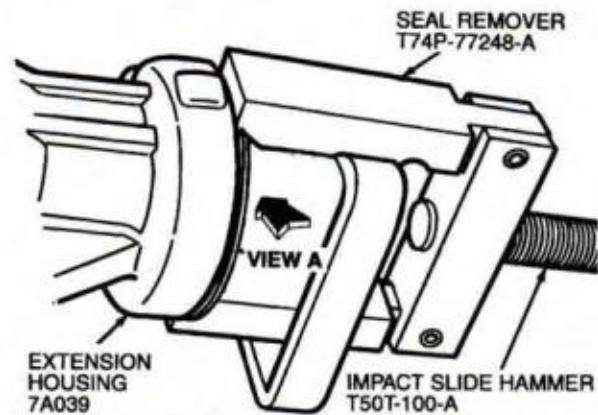

26. Inspect extension housing bushing (7A034). If required, remove the extension housing bushing using Extension Housing Bushing Remover T77L-7697-A.

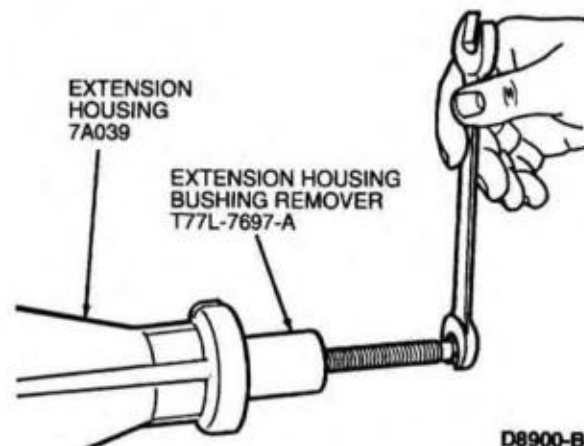

## DISASSEMBLY (Continued)

27. NOTE: The extension housing bolts have been coated with a sealant. More break torque may be required to remove these bolts.

Remove six extension housing bolts. Remove and discard extension housing gasket (7086).

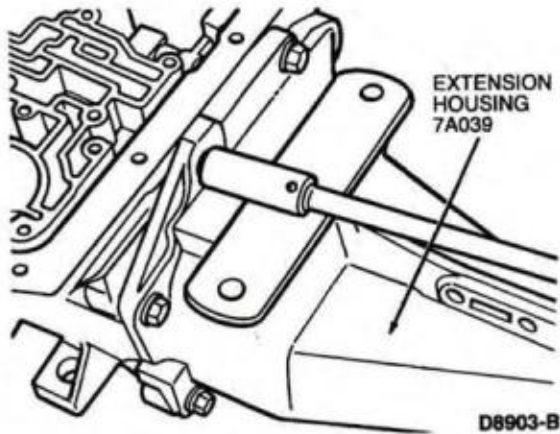

28. The output shaft may have shipping seal still attached. Remove and discard. This seal is not required for assembly.

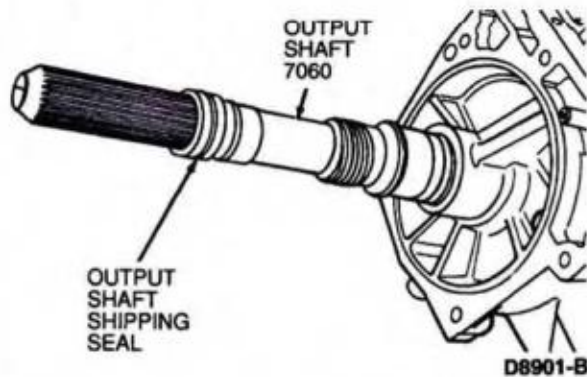

29. Slide parking pawl shaft (7D071) out of the case and remove parking pawl (7A441) and parking pawl return spring (7D070).
30. Place transmission in the vertical position with output shaft toward floor.

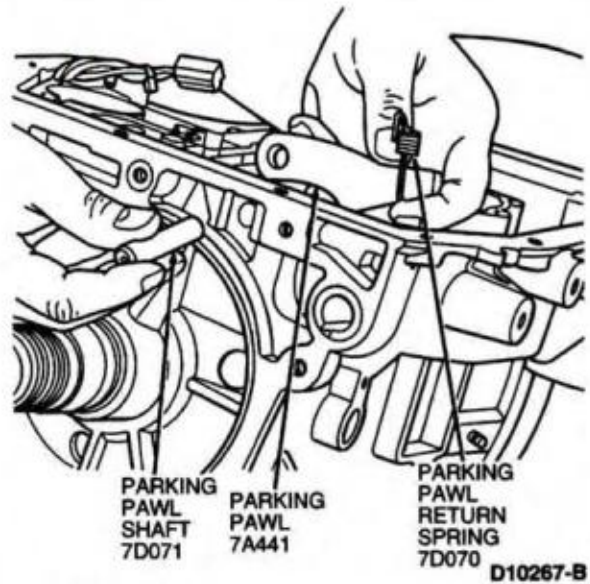

31. CAUTION: Extreme care must be taken during transmission connector removal. Do not pull on the wires, or use a hammer on the connector body. This will damage wires or connector and could result in a transmission concern.

Remove transmission connector from case. Place a screwdriver on the flat portion of the connector and drive the connector out through the bottom of the case.

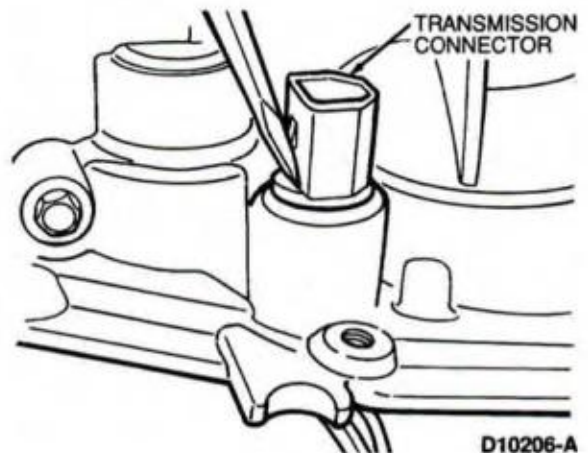

## DISASSEMBLY (Continued)

32. Remove front pump seal using Seal Remover TOOL-1175-AC or equivalent and Impact Slide Hammer T59L-100-B.

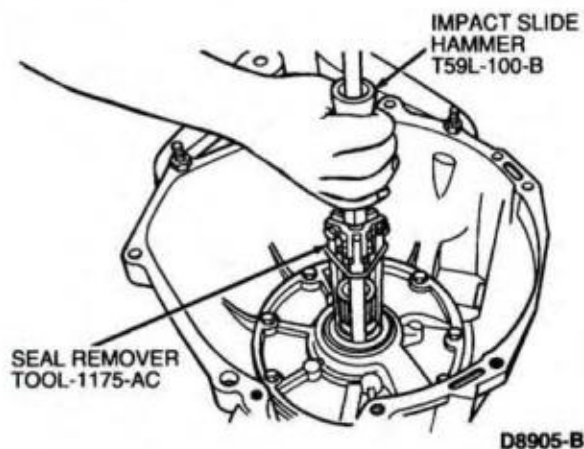

33. **NOTE:** All bolts have been coated with a sealant. More break torque might be required to remove bolts.  
Remove seven pump body retaining bolts.

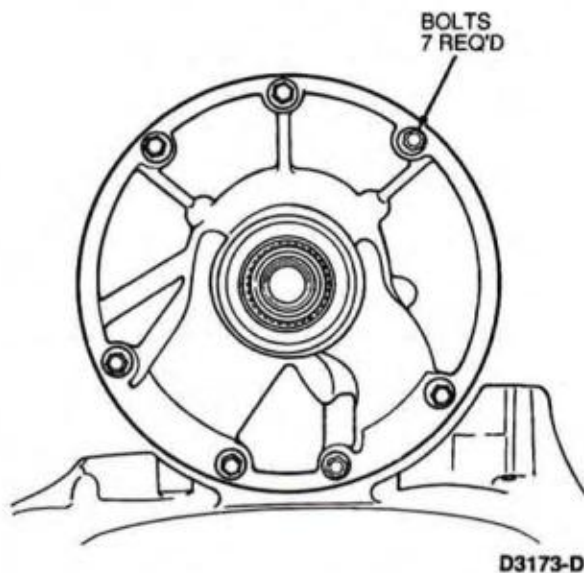

34. Remove front pump and support assembly using two Impact Slide Hammers T59L-100-B and Pump Puller Adapters T89T-70010-A.

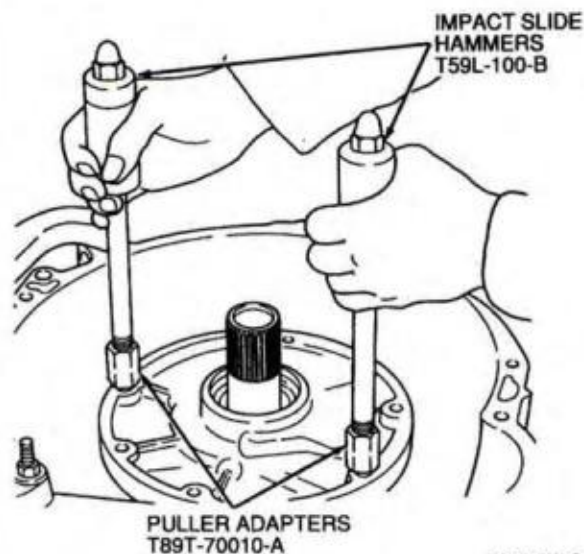

35. Remove and discard pump gasket.  
36. **CAUTION:** Remove the assembly carefully to prevent damage to the overdrive band friction material by the reverse clutch drive lugs.

Grasp the forward clutch cylinder and shaft (7F207) firmly and pull the following components out of the case as an assembly:

- intermediate clutch pack
- intermediate one-way clutch
- reverse clutch assembly
- forward clutch assembly

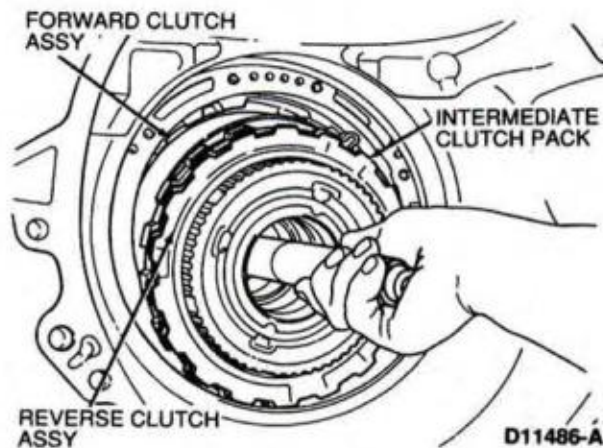

## DISASSEMBLY (Continued)

37. NOTE: Band may be removed with assembly.  
Disengage overdrive band (7F196) from overdrive band anchor pin (7F295) and remove.

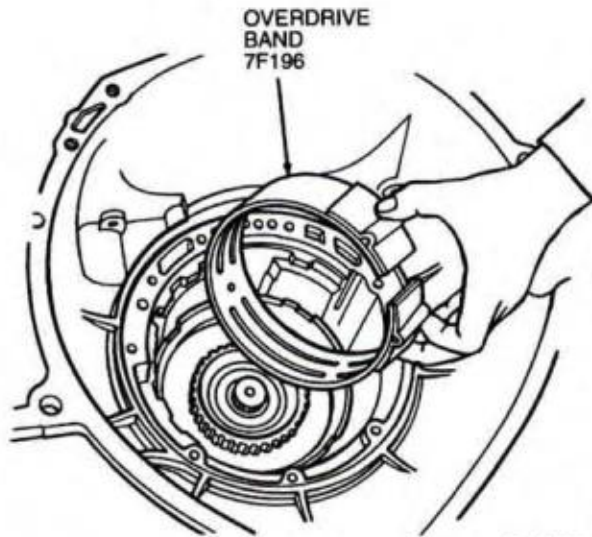

D8910-B

38. Remove forward clutch hub and the No. 3 forward clutch hub front bearing (7F231).

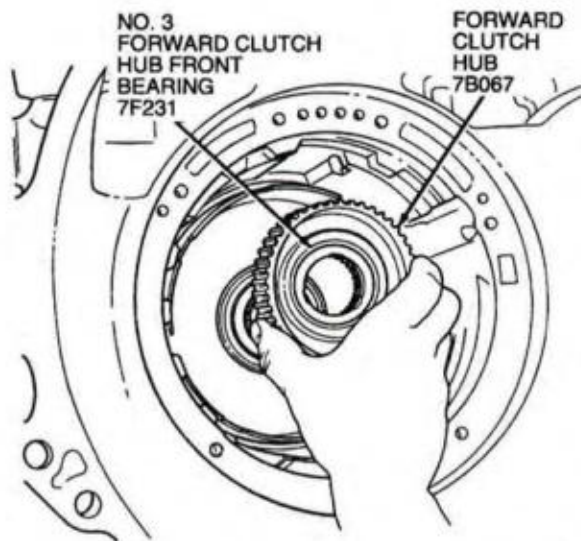

D3178-C

39. Remove intermediate stub shaft.

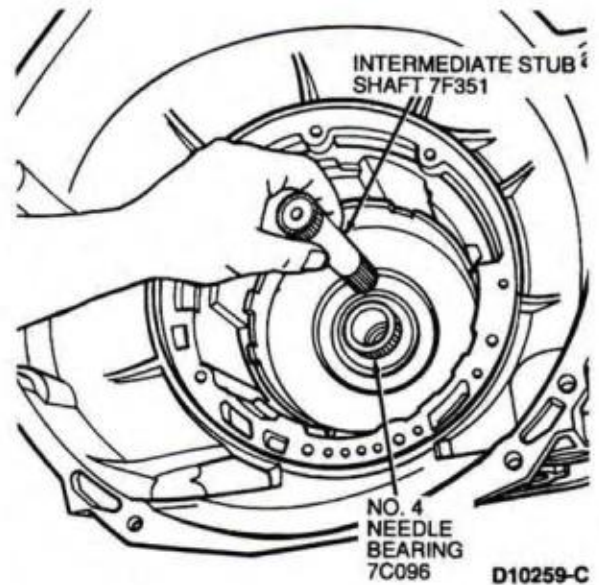

D10259-C

40. Rotate reverse clutch gear and shell (7A019) to align indent with overdrive band anchor pin.

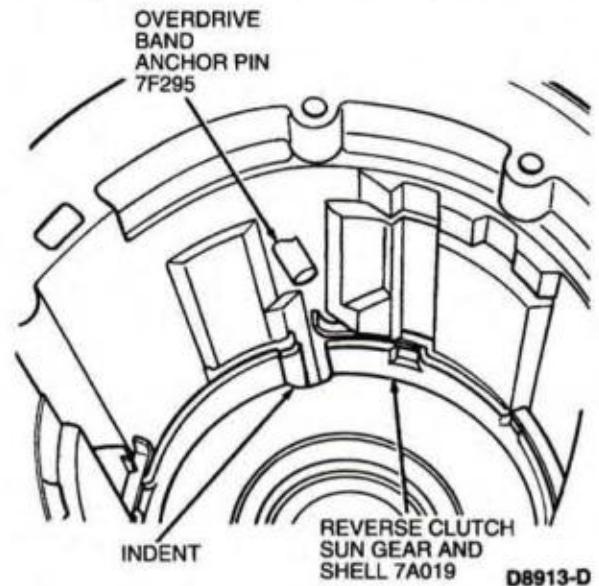

D8913-D

## DISASSEMBLY (Continued)

41. Remove forward clutch sun gear, No. 5 needle bearing, reverse clutch gear and shell and the No. 4 needle bearing as an assembly.

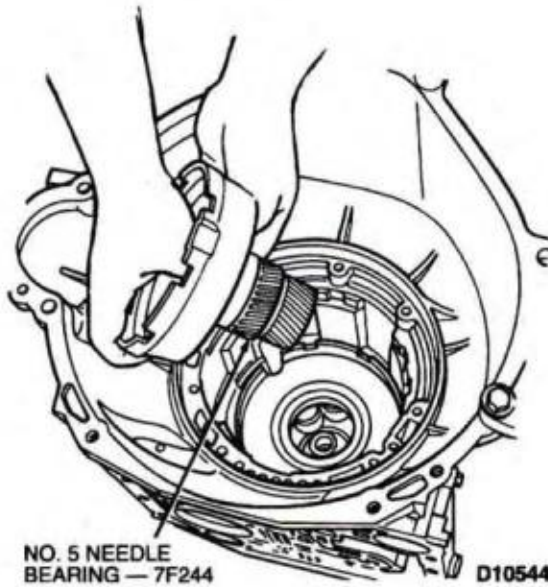

42. Remove center planet support retaining ring. Note position of retaining ring tabs for assembly.

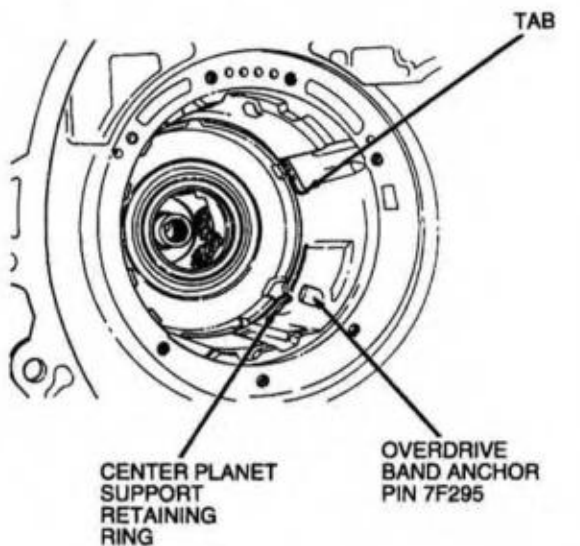

43. Using needle-nose pliers, remove case to center support spring out from between the center support and the case. Note location for assembly.

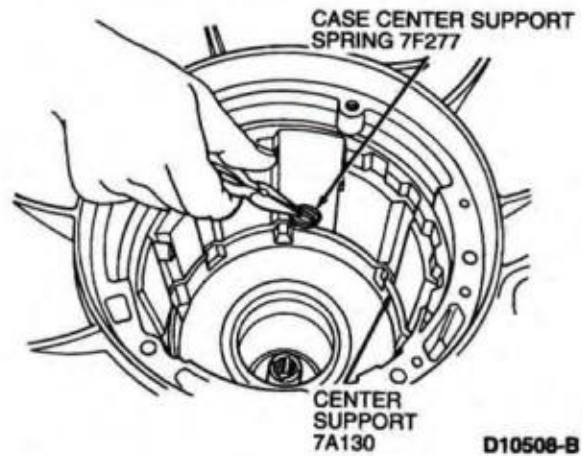

44. Remove planetary gear support and planetary as an assembly.

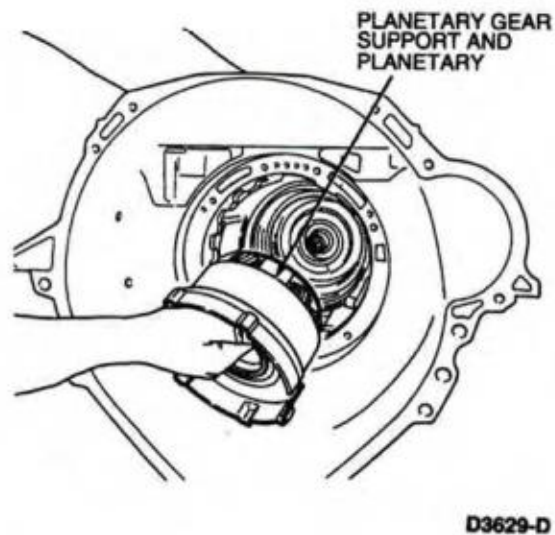

## DISASSEMBLY (Continued)

45. Remove reverse band.

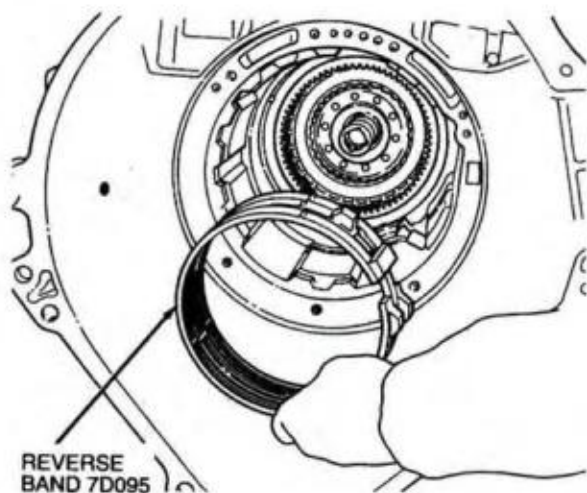

D3183-D

46. Remove retaining ring.

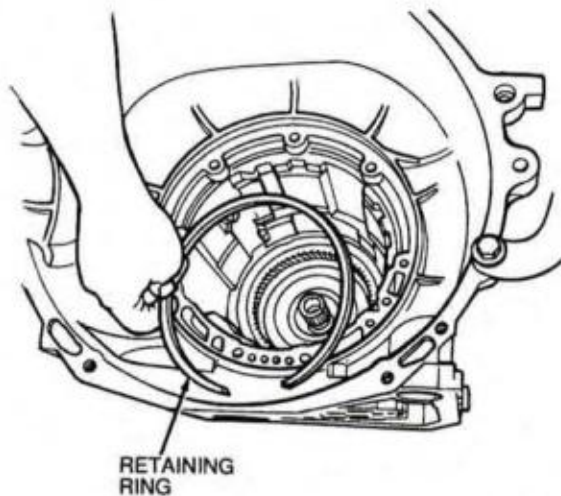

D10545-A

47. Remove output shaft, ring gear (7A153) and direct clutch assembly as a unit, from the front of the case.

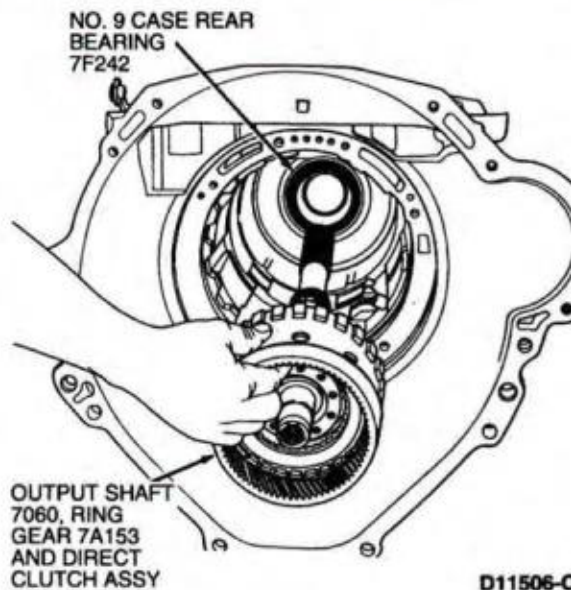

D11506-C

48. Remove No. 9 case rear bearing (7F242) from rear of the case.

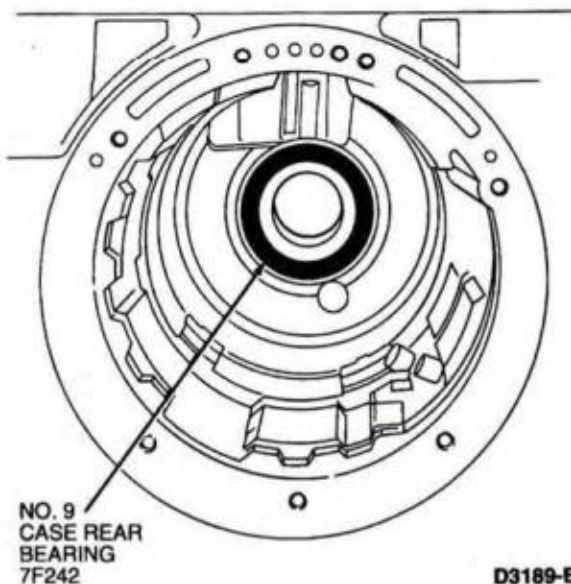

D3189-E

**DISASSEMBLY (Continued)**

49. Inspect output shaft bushing. If removal is required, use Bearing Cup Puller T77F-1102-A and Impact Slide Hammer T59L-100-B.

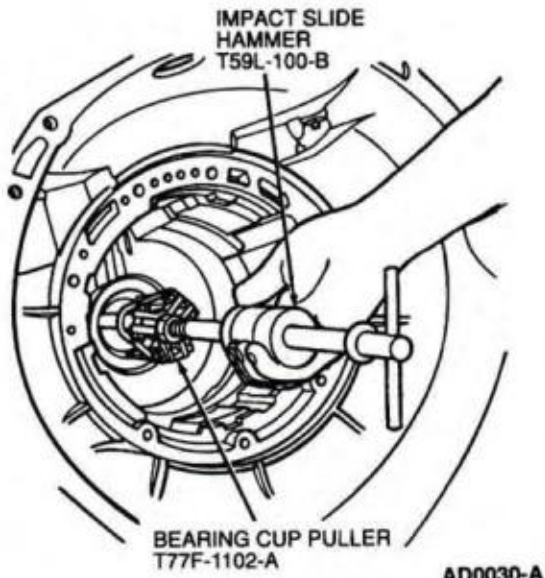
**DISASSEMBLY AND ASSEMBLY OF SUBASSEMBLIES****Service Notes**

**NOTE:** Before beginning Assembly, perform / inspect the following:

- All fasteners must be tightened to the torque indicated in the text. In addition to appearing in the text, the necessary torques can be found under Specifications.
- When building up subassemblies, each component part should be lubricated with clean Motorcraft MERCON® Multi-Purpose (ATF) Transmission XT-2-QDX or equivalent MERCON® approved fluid. It is also good practice to lubricate the subassemblies as they are installed in the case (7005).
- Needle bearings, thrust washers and seals should be lightly coated with petroleum jelly during subassembly build up or transmission assembly.
- Many components and surfaces in the transmission are precision machined. Careful handling during disassembly, cleaning, inspection and assembly can prevent unnecessary damage to machined surfaces.

When building up subassemblies and assembling the transmission, ALWAYS use new gaskets and seals.

### DISASSEMBLY AND ASSEMBLY OF SUBASSEMBLIES (Continued)

#### Main Control Valve Body

Disassembled View

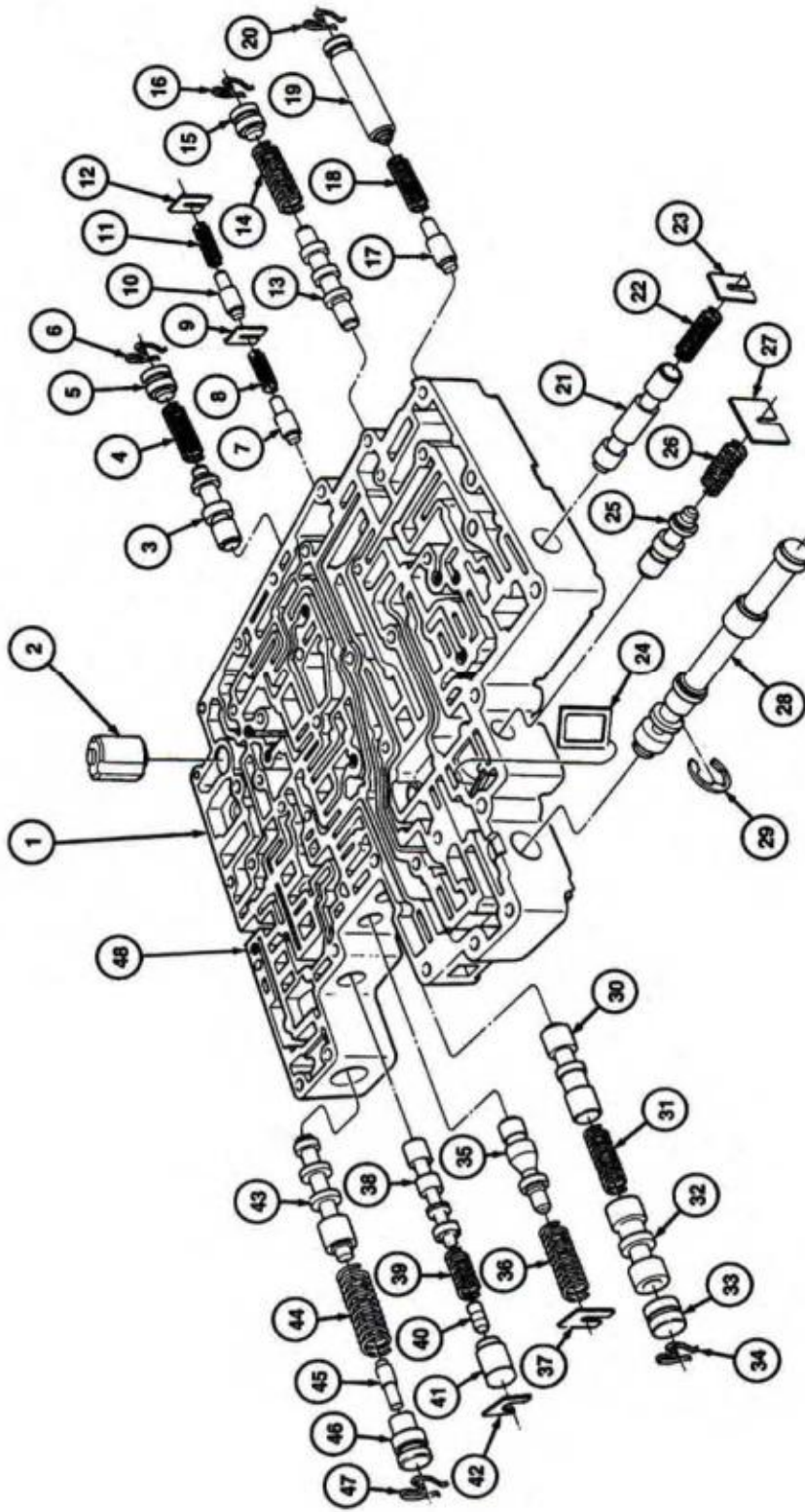

AD00033-A

**DISASSEMBLY AND ASSEMBLY OF  
SUBASSEMBLIES (Continued)**

Item	Part Number	Description
1	7A100	Main Control Valve Body Assy
2	—	Valve - Converter Drain Back (Part of 7A100)
3	—	Valve - Pressure Regulator (Part of 7A100)
4	—	Spring - Pressure Regulator Valve (Part of 7A100)
5	—	Plug - Valve Retainer (Part of 7A100)
6	—	Retainer - Valve Plug (Part of 7A100)
7	—	Valve - Capacity Modulator (Part of 7A100)
8	—	Spring - Capacity Modulator Valve (Part of 7A100)
9	—	Plate - Spring Retaining (Part of 7A100)
10	—	Valve - Capacity Modulator (Part of 7A100)
11	—	Spring - Capacity Modulator Valve (Part of 7A100)
12	—	Plate - Spring Retaining (Part of 7A100)
13	—	Valve - 3-4 Shift (Part of 7A100)
14	—	Spring - 3-4 Shift Valve (Part of 7A100)
15	—	Plug - Valve Retainer (Part of 7A100)
16	—	Retainer - Valve Plug (Part of 7A100)
17	—	Valve - Capacity Modulator (Part of 7A100)
18	—	Spring - Capacity Modulator Valve (Part of 7A100)
19	—	Plug - Valve Retainer (Part of 7A100)
20	—	Retainer - Valve Plug (Part of 7A100)
21	—	Valve - 2-3 Backout (Part of 7A100)
22	—	Spring - 2-3 Backout (Part of 7A100)
23	—	Plate - Spring Retaining (Part of 7A100)
24	—	Screen - Solenoid (Part of 7A100)
25	—	Valve - Pressure Regulator (Part of 7A100)

(Continued)

Item	Part Number	Description
26	—	Spring - Pressure Regulator Valve (Part of 7A100)
27	—	Plate - Spring Retaining (Part of 7A100)
28	—	Valve - Control Manual (Part of 7A100)
29	—	Ring - Retaining (Part of 7A100)
30	—	Valve - 1-2 Shift (Part of 7A100)
31	—	Spring - 2-3 Shift Valve (Part of 7A100)
32	—	Valve - 2-3 Shift (Part of 7A100)
33	—	Plug - Valve Retaining (Part of 7A100)
34	—	Retainer - Valve Plug (Part of 7A100)
35	—	Valve - Pressure Regulator (Part of 7A100)
36	—	Spring - Pressure Regulator Valve (Part of 7A100)
37	—	Plate - Spring Retaining (Part of 7A100)
38	—	Valve - Bypass Clutch Control (Part of 7A100)
39	—	Spring - Bypass Clutch Control Valve (Part of 7A100)
40	—	Plunger - Bypass Clutch Control Valve (Part of 7A100)
41	—	Sleeve - Bypass Clutch Control Plunger (Part of 7A100)
42	—	Plate - Control Valve (Part of 7A100)
43	—	Valve - Main Regulator (Part of 7A100)
44	—	Spring - Main Oil Pressure Regulator Valve (Part of 7A100)
45	—	Valve - Main Oil Pressure Booster (Part of 7A100)
46	—	Sleeve - Main Oil Pressure Booster Valve (Part of 7A100)
47	—	Retainer - Valve Plug (Part of 7A100)
48	—	Check Ball (8 Req'd) (Part of 7A100)

**Disassembly**

1. Remove retaining bolt and shift solenoid bracket.

## DISASSEMBLY AND ASSEMBLY OF SUBASSEMBLIES (Continued)

- Remove shift solenoid (7G484) assembly and torque converter clutch solenoid (TCC solenoid)(7G136) by pulling straight up.

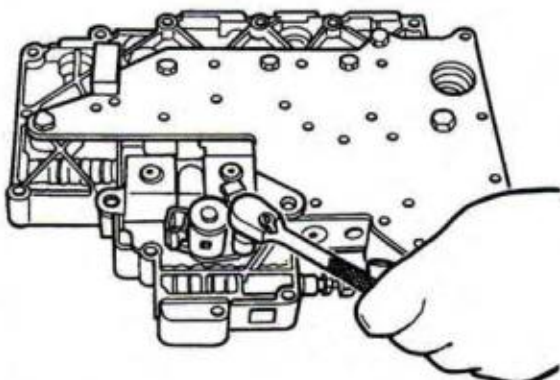

D10573-A

- Turn main control valve body (7A100) over and remove 10 bolts retaining reinforcement and separator plates.

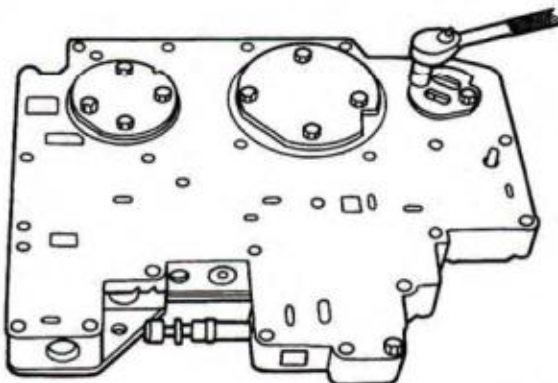

D10574-A

- Remove separator plate and gaskets. Discard gaskets.

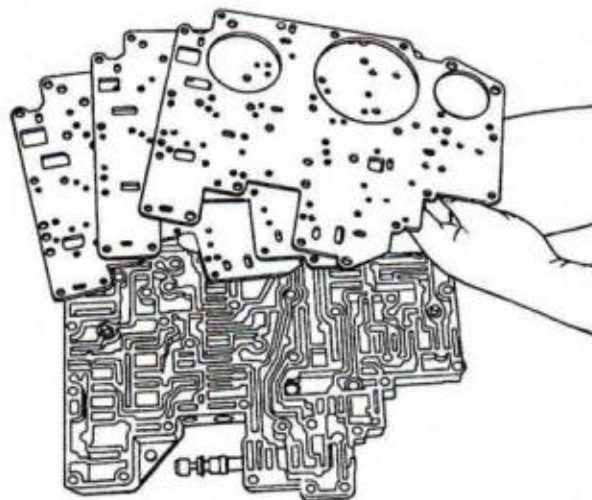

D10575-A

- Note location and remove check balls. Remove solenoid screen.

### DISASSEMBLY AND ASSEMBLY OF SUBASSEMBLIES (Continued)

#### Check Ball Locations

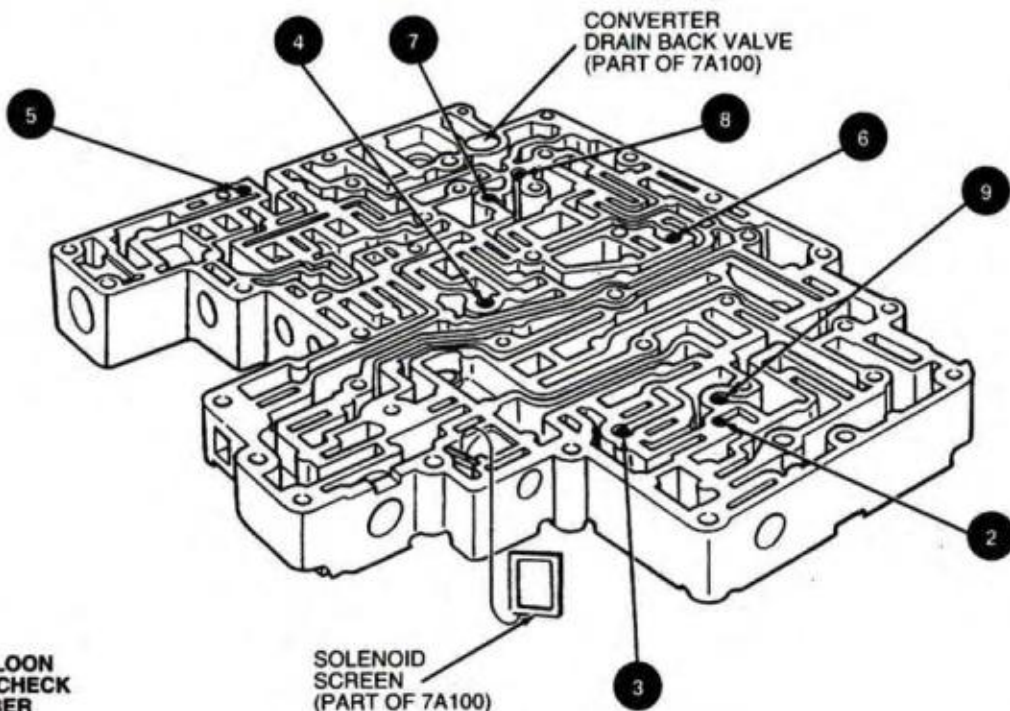

**NOTE: BALLOON INDICATES CHECK BALL NUMBER**

SOLENOID SCREEN (PART OF 7A100)

D14645-B

- 6. Remove converter drain back valve.
- 7. Remove eleven valve body cover plate bolts and two guide pin bolts.

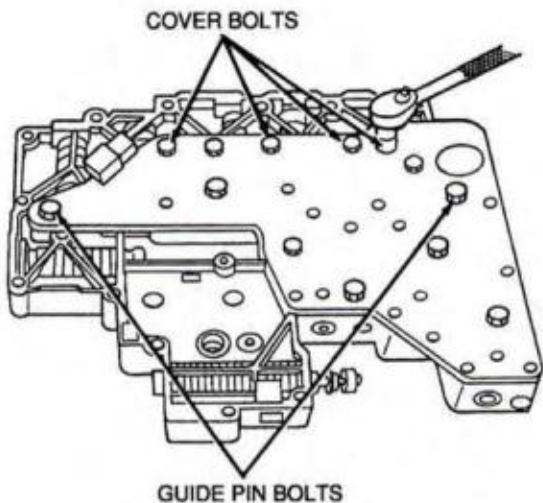

D10578-C

- 8. Remove main control cover (7G004).

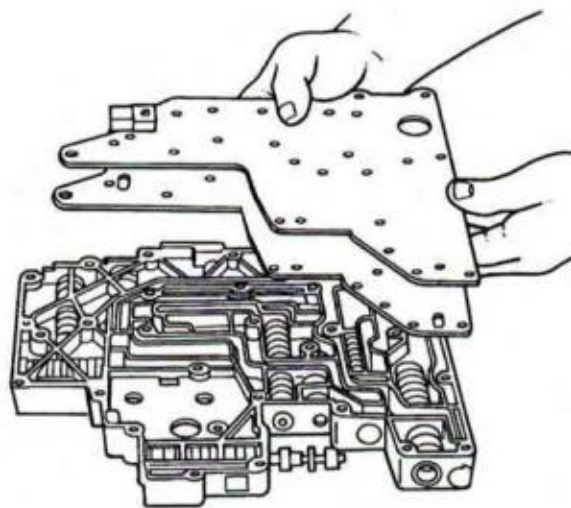

D10579-A

#### Assembly

- 1. Install main control cover.

ProCarMan.com

## DISASSEMBLY AND ASSEMBLY OF SUBASSEMBLIES (Continued)

2. Install two guide pin bolts and eleven valve body cover retaining bolts. Tighten guide pin bolts to 9-11 N·m (80-97 lb-in) and valve body cover retaining bolts to 9-11 N·m (80-97 lb-in) in sequence shown.

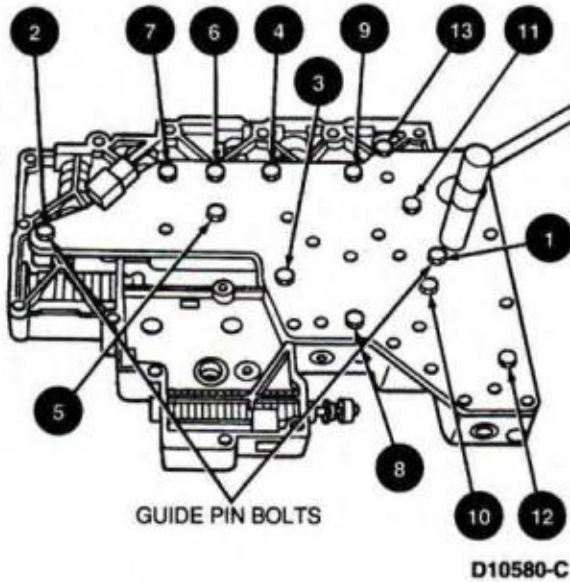

3. Install coasting booster valve shuttle balls (7E195), converter drain back valve and solenoid screen.
4. Install separator plate and new gaskets.
5. Install reinforcement plates. Tighten retaining bolts to 9-11 N·m (80-97 lb-in) in sequence shown.

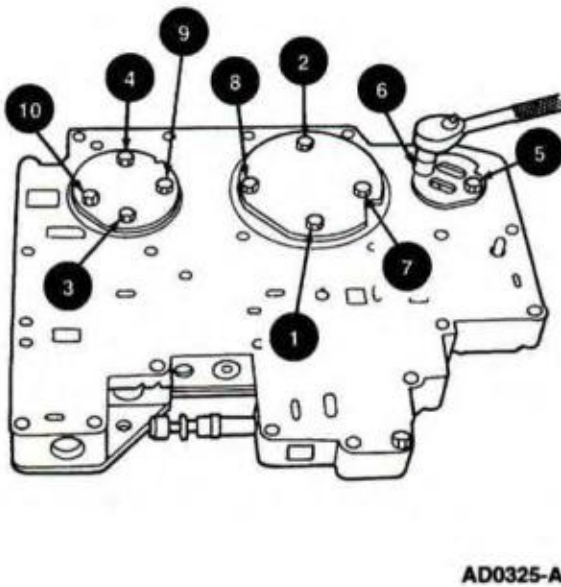

6. Inspect O-rings on solenoids for damage. Install shift solenoid assembly and torque converter clutch solenoid.

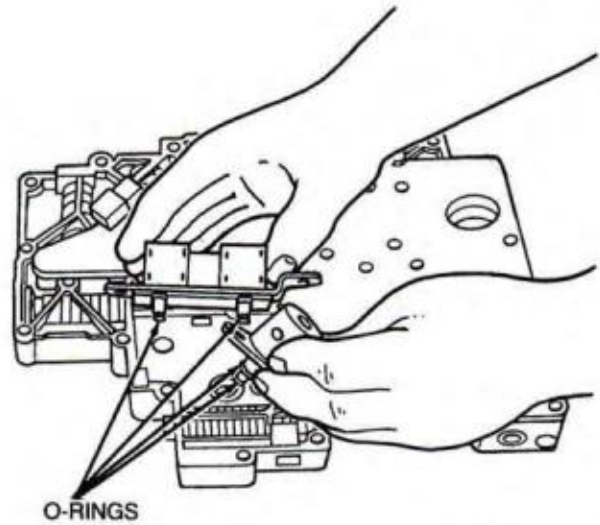

D10581-A

7. Install bracket and retaining bolt. Tighten to 9-11 N·m (80-97 lb-in).

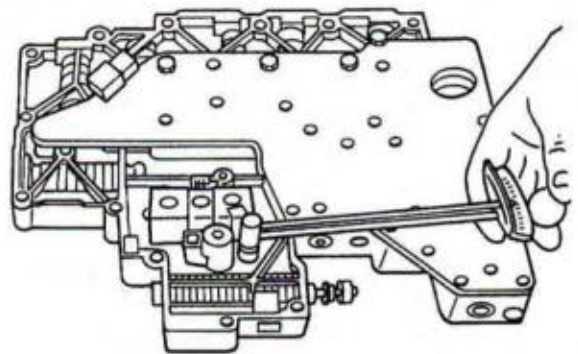

## DISASSEMBLY AND ASSEMBLY OF SUBASSEMBLIES (Continued)

### Pump and Intermediate Clutch Piston— Disassembly

Disassembled View

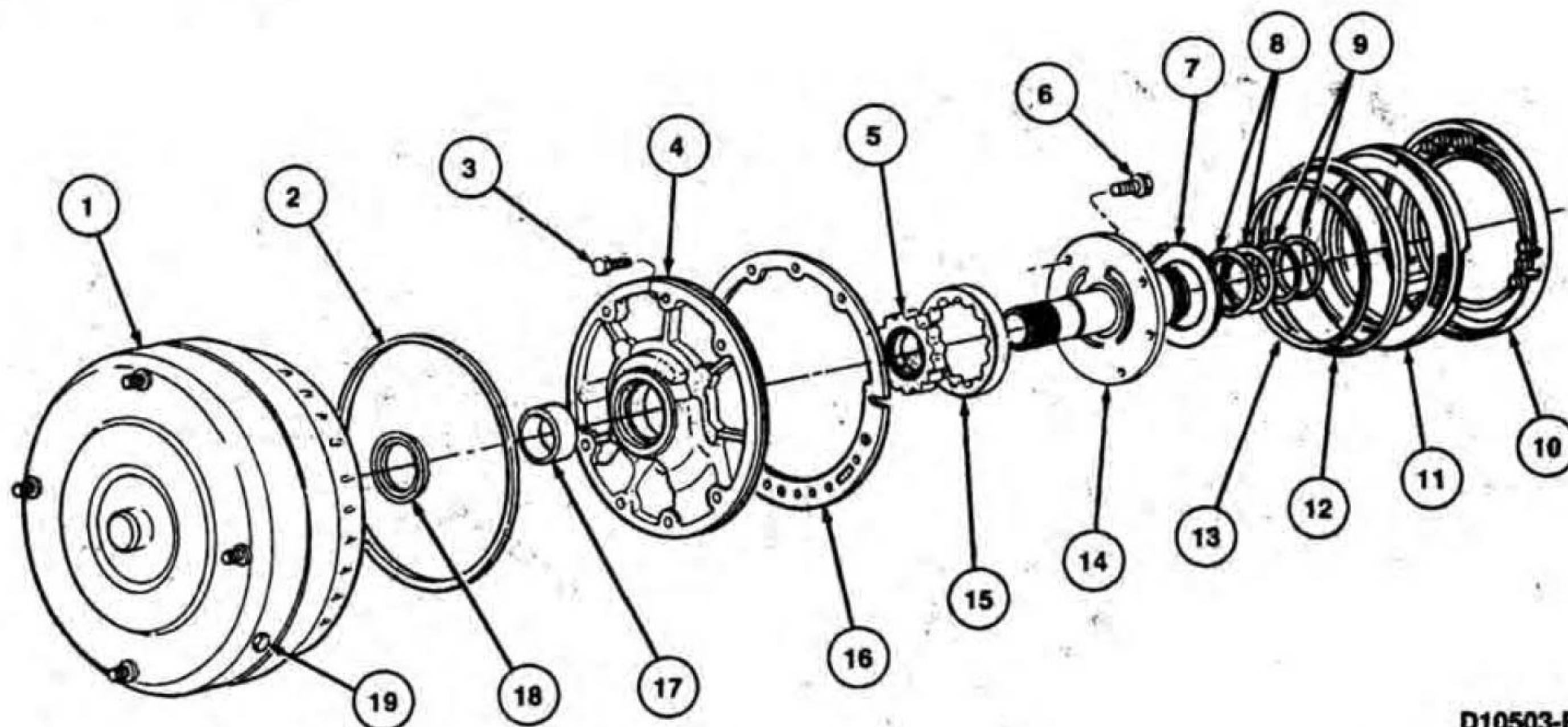

D10503-B

Item	Part Number	Description
1	7902	Torque Converter
2	7A248	Front Pump Seal
3	N605789-S100	Bolt (7 Req'd)
4	7A106	Front Pump Assy
5	7H169	Pump Inner Gerotor
6	N605787-S1000	Bolt (5 Req'd)
7	7D014	Thrust Washer
8	7D020	Reverse Clutch Cylinder Seal (2 Req'd)
9	7D019	Forward Clutch Cylinder Seals (2 Req'd)
10	7A577	Intermediate Clutch Retainer Spring Assy

Item	Part Number	Description
11	7E005	Intermediate Clutch Piston
12	7F224	Intermediate Clutch Piston Outer Seal
13	7F225	Intermediate Clutch Piston Inner Seal
14	7A108	Front Pump Stator Support
15	7H169	Pump Outer Gerotor
16	7A136	Pump Gasket
17	7B258	Front Pump Bushing
18	7A248	Front Pump Inner Seal
19	87650-S2	Converter Drain Plug

(Continued)

## DISASSEMBLY AND ASSEMBLY OF SUBASSEMBLIES (Continued)

### Disassembly

1. Remove the No. 1 thrust washer (7D014).

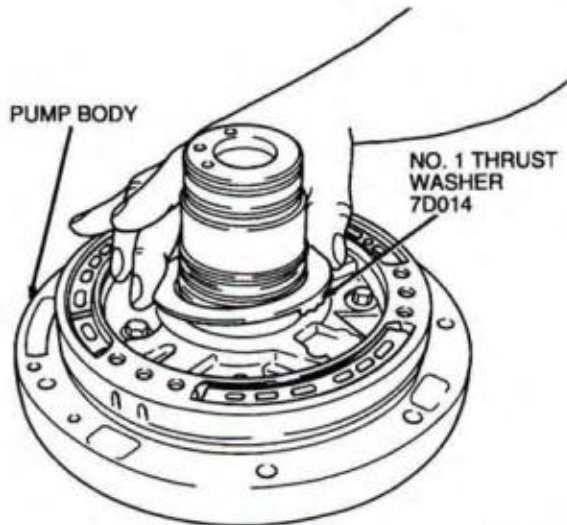

D3833-E

2. Remove five front pump support bolts. Separate front pump support (7A108) and pump assembly.

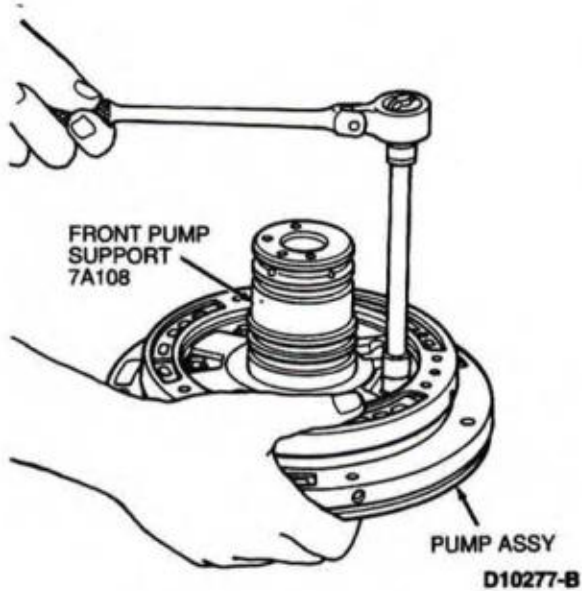

3. **NOTE:** The reverse clutch seals are larger than the forward clutch seals.  
Remove two each of reverse clutch cylinder seals (7D020) and forward clutch seals.

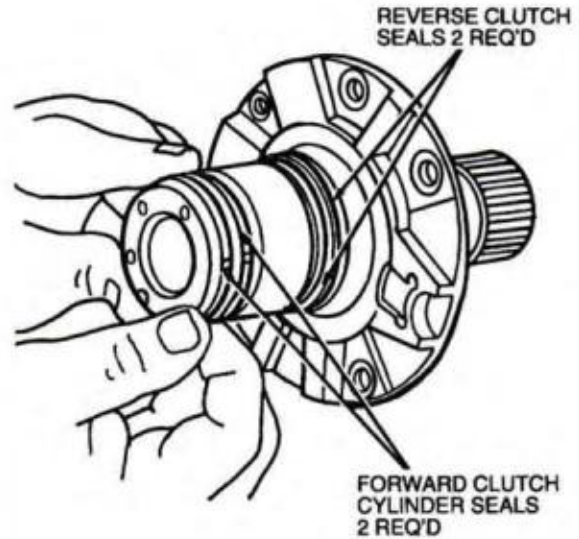

D11466-B

4. Remove inner and outer pump gerotors from pump body.

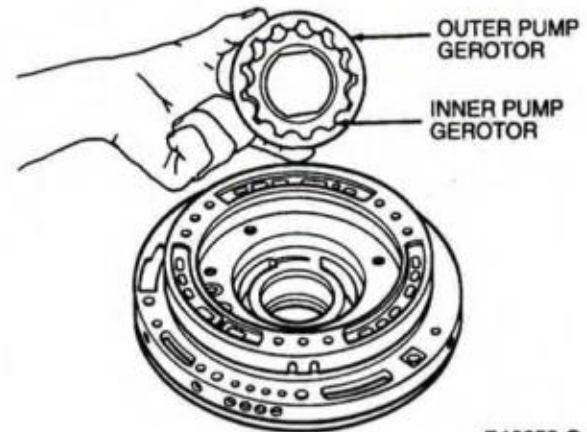

D10250-C

## DISASSEMBLY AND ASSEMBLY OF SUBASSEMBLIES (Continued)

5. Remove spring retainer assembly by carefully dislodging the tabs.

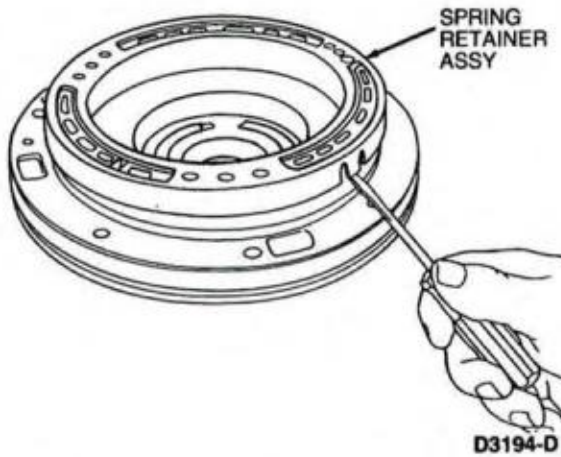

6. Remove intermediate clutch piston (7E005) and intermediate clutch piston inner seal (7F225) and intermediate clutch piston outer seal (7F224).

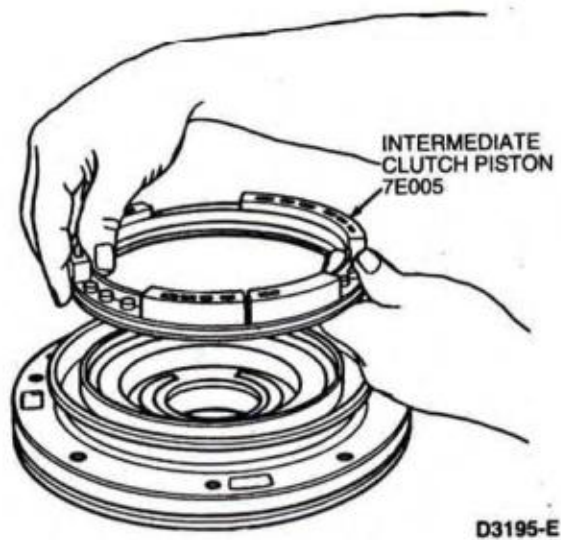

7. Remove front pump seal and discard.

FRONT PUMP SEAL 7A248

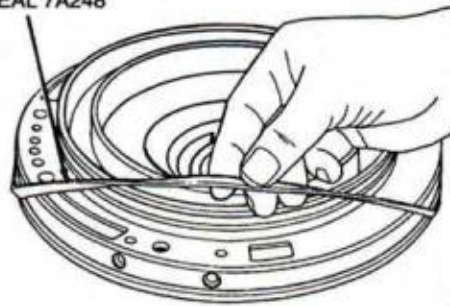

### Pump and Intermediate Clutch Piston—Assembly

#### SPECIAL SERVICE TOOL(S) REQUIRED

Description	Tool Number
Front Pump Seal Replacer	T63L-77837-A
Intermediate Clutch Piston Seal Protector	T95L-77005-A

#### Assembly

1. Install the front pump seal using Front Pump Seal Replacer T63L-77837-A.

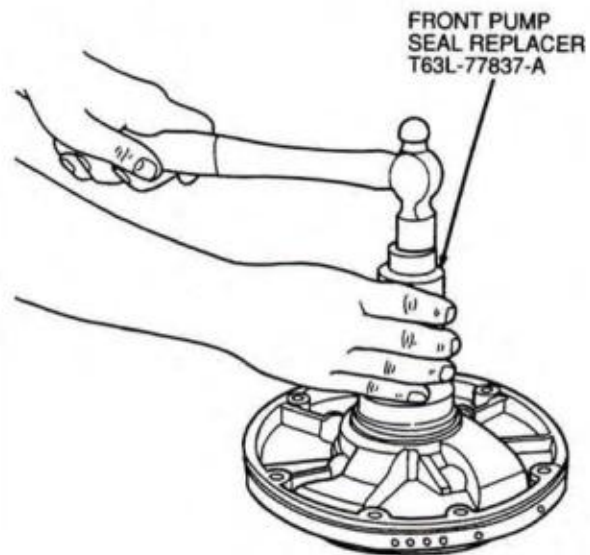

## DISASSEMBLY AND ASSEMBLY OF SUBASSEMBLIES (Continued)

2. Install new intermediate clutch piston inner seal (7F225) and intermediate clutch piston outer seal (7F224) on intermediate clutch piston (7E005).

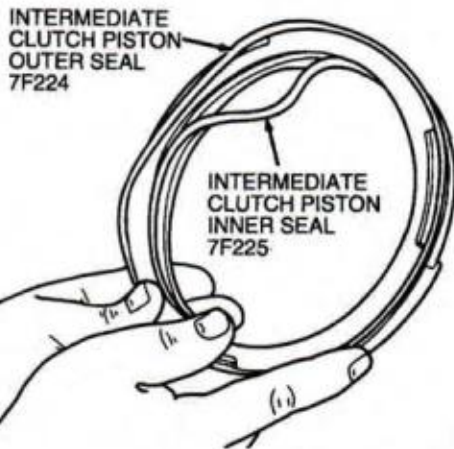

D10274-B

3. **CAUTION:** The piston bleed hole must be located at 12 o'clock position (toward top of transmission). If incorrectly installed, transmission may not operate properly.

NOTE: Piston bleed hole is the only round hole in the intermediate clutch piston assembly.

Note location of the piston bleed hole.

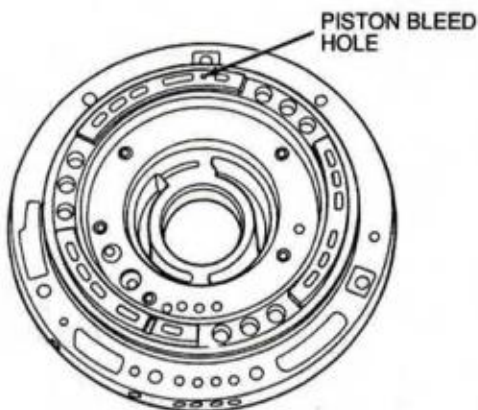

D10276-A

4. NOTE: Coat intermediate clutch piston outer seal and intermediate clutch piston inner seal and pump body sealing area with petroleum jelly. Install intermediate clutch piston as follows:
- Install intermediate clutch piston in Intermediate Clutch Piston Seal Protector T95L-77005-A.

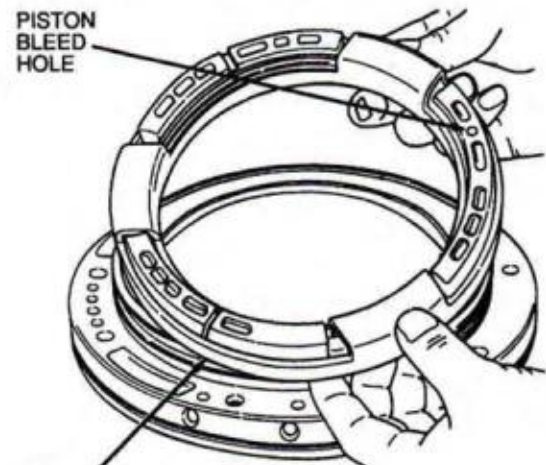

INTERMEDIATE CLUTCH PISTON SEAL PROTECTOR T95L-77005-A

D3269-D

5. Install intermediate clutch piston in pump body and push intermediate clutch piston to the bottom of the bore by exerting even pressure.



D3637-D

## DISASSEMBLY AND ASSEMBLY OF SUBASSEMBLIES (Continued)

6. Snap spring retainer assembly into place on pump body.

SPRING RETAINER  
APPLY EVEN PRESSURE  
TO INSTALL



D3270-C

7. Install the inner and outer pump gerotors in pump body.

The flats have steps that must face the pump body for ease of installing the torque converter (7902).

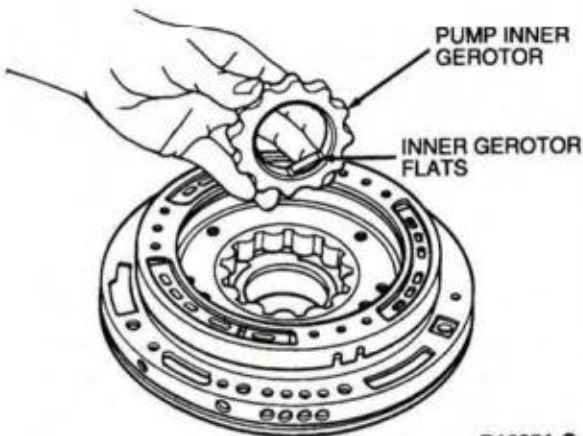

D10251-C

8. Install reverse clutch cylinder seal (7D020) and forward clutch cylinder seals.

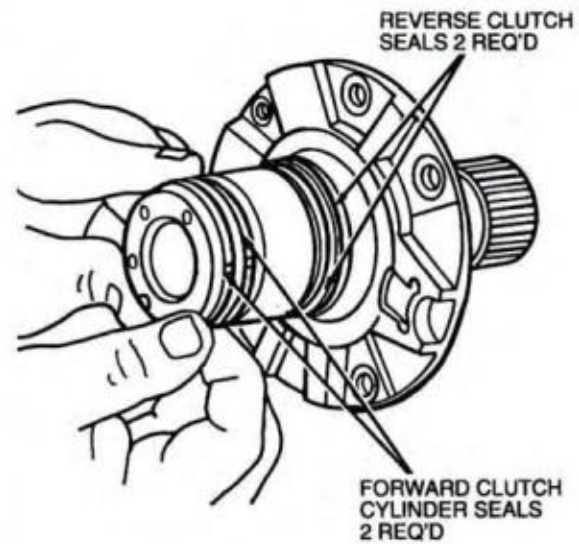

D11466-B

9. Position pump stator support to pump body and install retaining bolts. Tighten to 20-26 N·m (15-19 lb·ft).

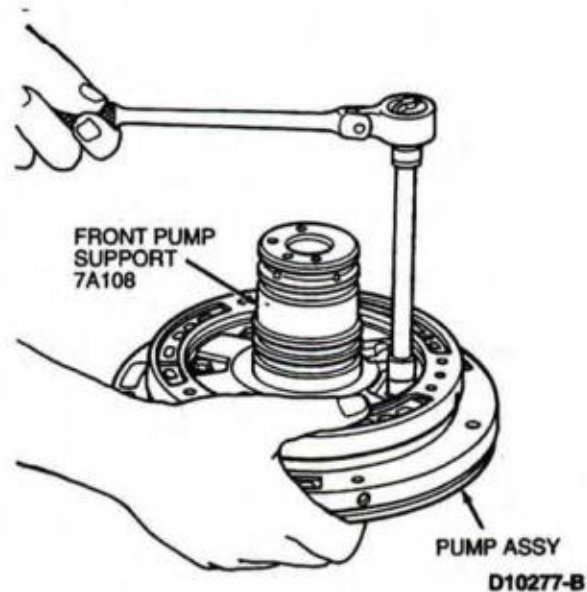

D10277-B

## DISASSEMBLY AND ASSEMBLY OF SUBASSEMBLIES (Continued)

### Intermediate Clutch Cylinder

NOTE: One-way clutch must rotate counterclockwise when installed on drum.

#### Disassembled View

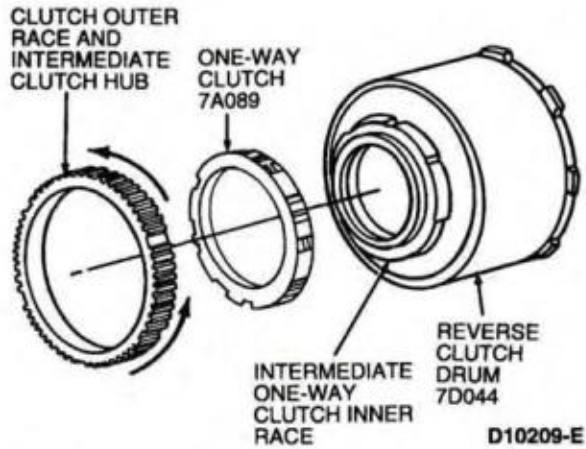

#### Disassembly

1. Remove clutch retaining ring.

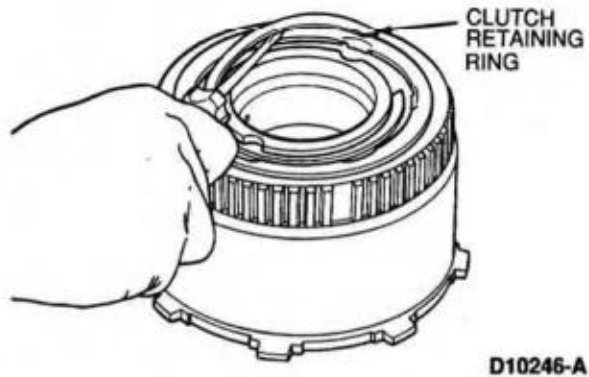

2. Remove one-way clutch retainer.

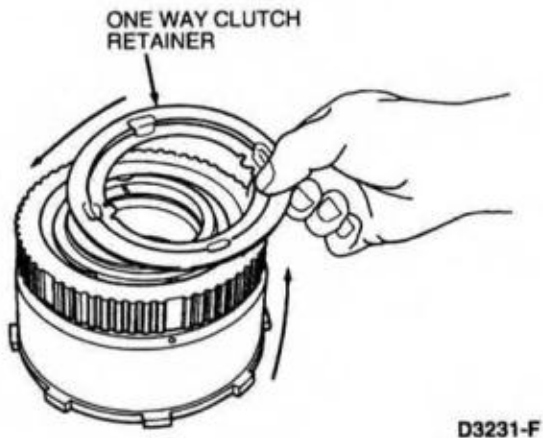

3. Remove clutch outer race by lifting on the race while turning counterclockwise.  
Carefully lift one-way clutch from reverse clutch drum (7D044).

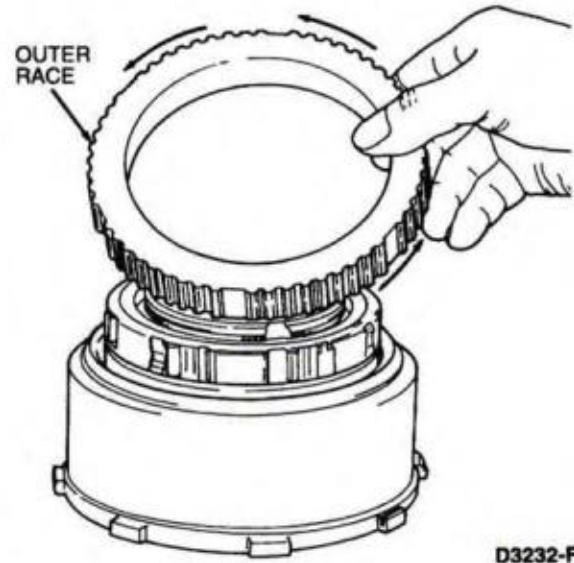

#### Assembly

NOTE: For ease in assembly, the chamfer on the outer clutch race splines should face upward.

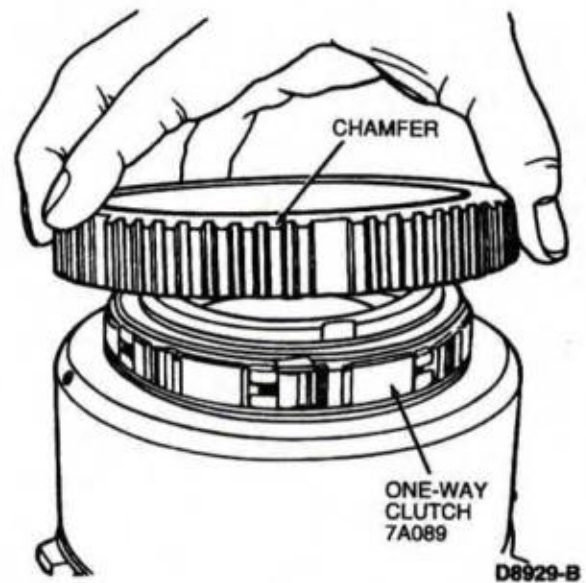

1. NOTE: One-way clutch must rotate counterclockwise when installed on reverse clutch drum.  
Install one-way clutch on reverse clutch drum.

## DISASSEMBLY AND ASSEMBLY OF SUBASSEMBLIES (Continued)

2. Install clutch outer race.

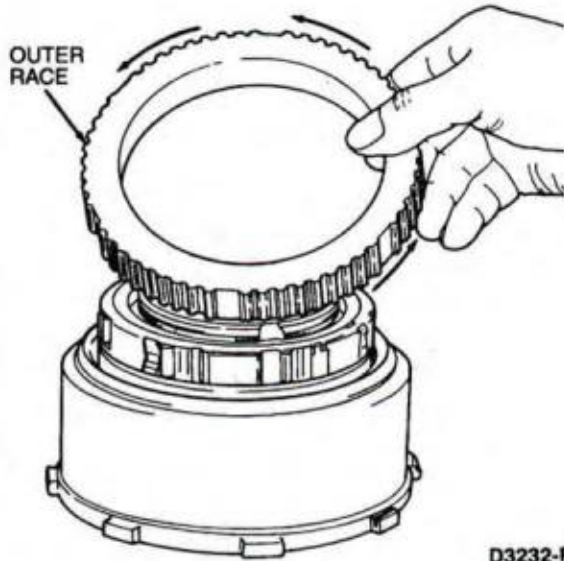

D3232-F

3. Install one-way clutch retainer and springs.

4. Install clutch retaining ring.

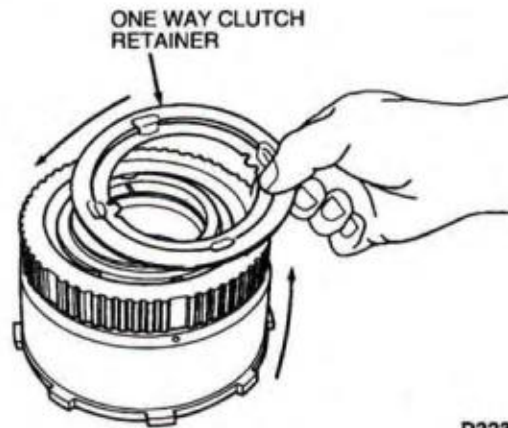

D3231-F

### Reverse Clutch

Disassembled View

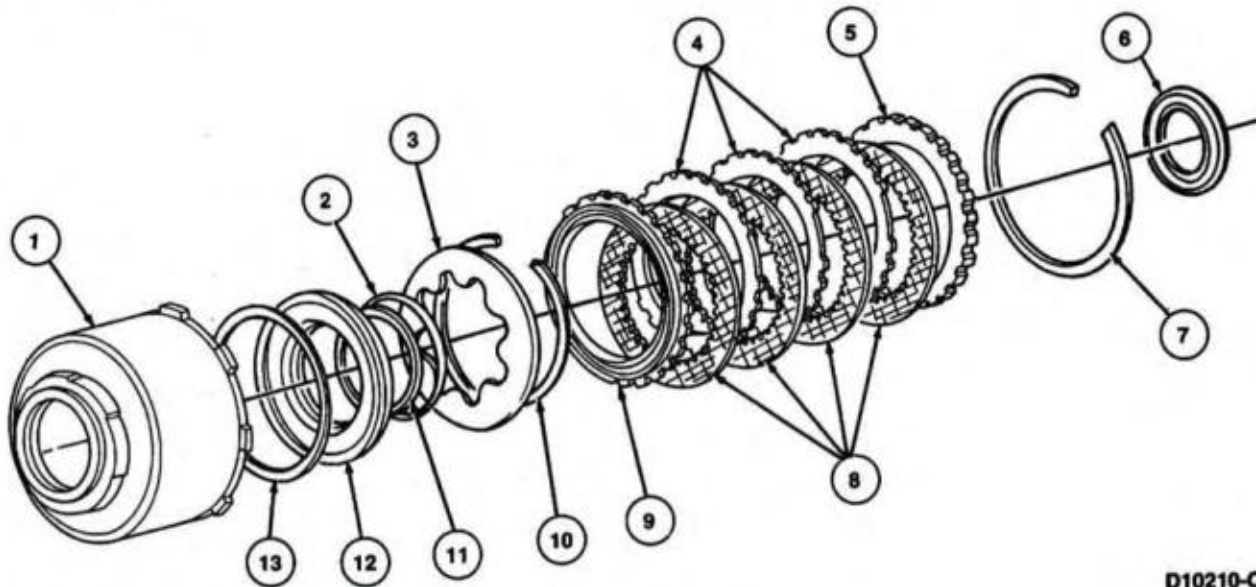

D10210-C

Item	Part Number	Description
1	7D044	Reverse Clutch Drum
2	7D256	Reverse Clutch Piston Spring Pressure Ring
3	7B070	Reverse Clutch Piston Spring

(Continued)

Item	Part Number	Description
4	7B442	Reverse Clutch External Spline Clutch Plate
5	7B066	Clutch Pressure Plate
6	7A166	Forward Clutch Bearing

(Continued)

## DISASSEMBLY AND ASSEMBLY OF SUBASSEMBLIES (Continued)

Item	Part Number	Description
7	7D483	Clutch Pressure Plate Retainer Snap Ring
8	7B164	Reverse Clutch Internal Spline (Friction) Plates
9	7B066	Clutch Pressure Plate
10	7A577	Clutch Pressure Plate Retainer Snap Ring

(Continued)

Item	Part Number	Description
11	7D404	Reverse Clutch Piston Small Seal
12	7D402	Reverse Clutch Piston
13	7D403	Reverse Clutch Piston Outer Seal

### Disassembly

#### SPECIAL SERVICE TOOL(S) REQUIRED

Description	Tool Number
Clutch Spring Compressor	T65L-77515-A
Reverse Clutch Spring Compressor	T80L-77405-A
Reverse Clutch Inner Seal Protector	T80L-77403-B
Reverse Clutch Outer Seal Protector	T80L-77403-A

1. Remove No. 2 needle bearing.

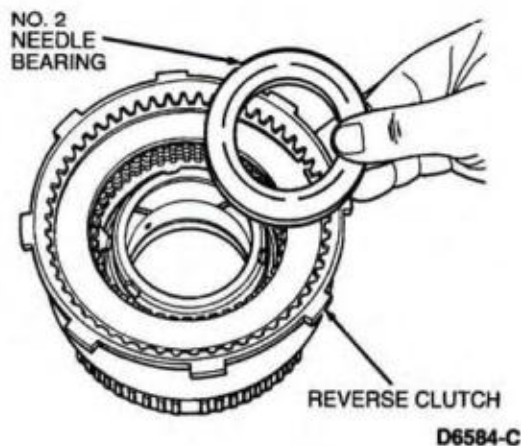

2. Remove clutch pressure plate retainer snap ring (7D483).

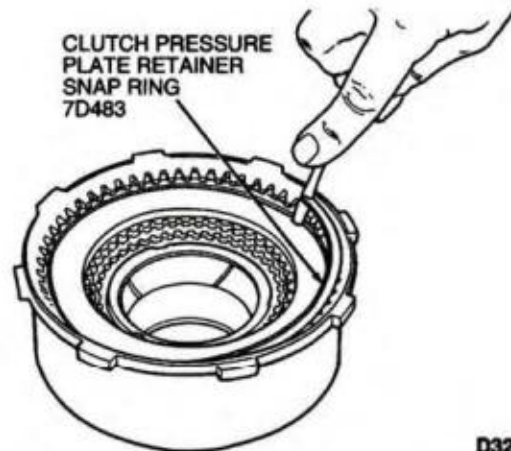

3. Remove clutch pack.

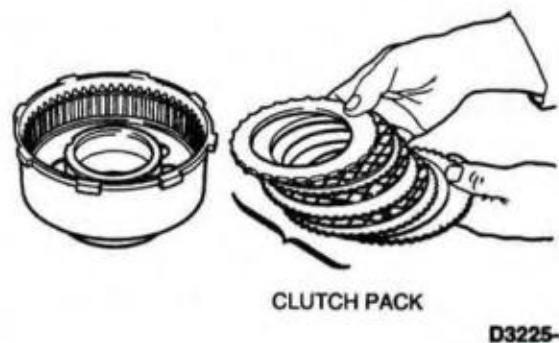

## DISASSEMBLY AND ASSEMBLY OF SUBASSEMBLIES (Continued)

4. Install Reverse Clutch Spring Compressor T80L-77405-A and Clutch Spring Compressor T65L-77515-A onto reverse clutch drum (7D044). Tighten enough to compress reverse clutch piston spring (7B070). Remove clutch pressure plate retainer snap ring (7A577).

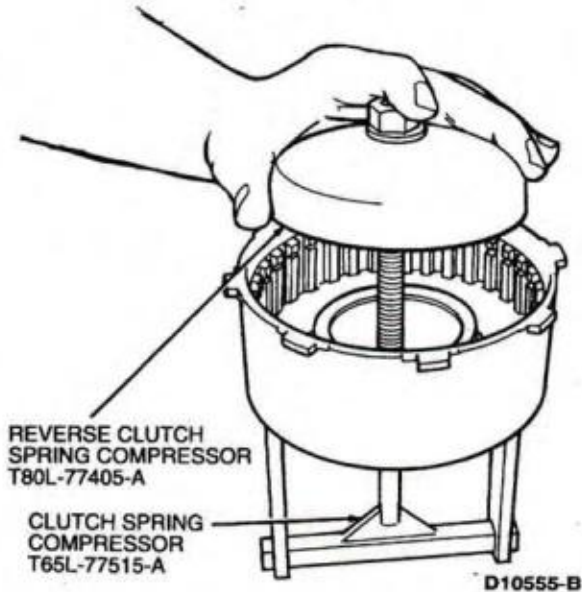

5. NOTE: To aid in reverse clutch piston spring removal, it may be necessary to apply air pressure to the reverse clutch drum. Block the opposite hole with a finger. Remove reverse clutch piston (7D402), reverse clutch piston spring and reverse clutch piston spring pressure ring (7D256).

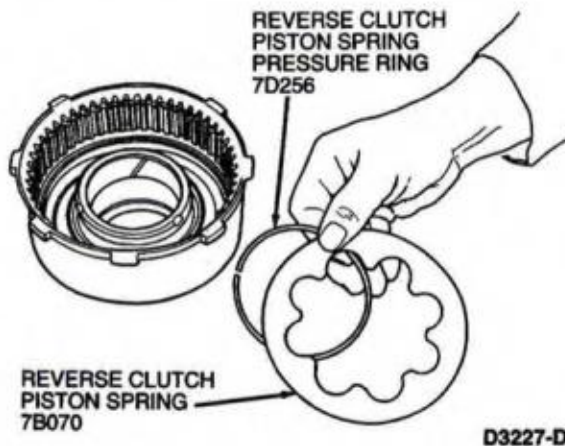

6. Remove reverse clutch piston and reverse clutch piston small seal (7D404) and reverse clutch piston outer seal (7D403).

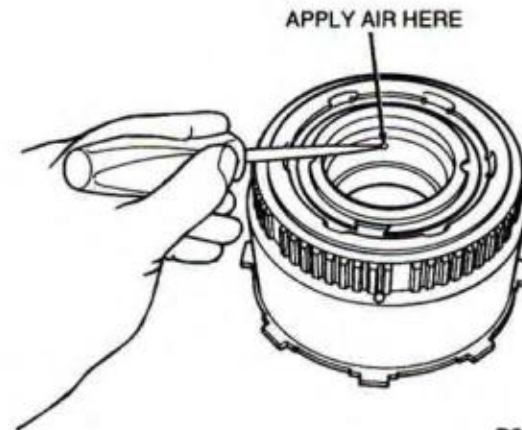

### Assembly

1. NOTE: The piston check ball must be present and moving freely.

NOTE: Coat reverse clutch piston outer seal and reverse clutch piston small seal, reverse clutch drum, sealing area and seal protector with petroleum jelly.

Install new reverse clutch piston small seal and reverse clutch piston outer seal on reverse clutch piston. Direction of installation is not important because seals are square cut.

**NOTE: THE SEALS ARE SQUARE AND THEREFORE CAN BE INSTALLED IN EITHER DIRECTION.**

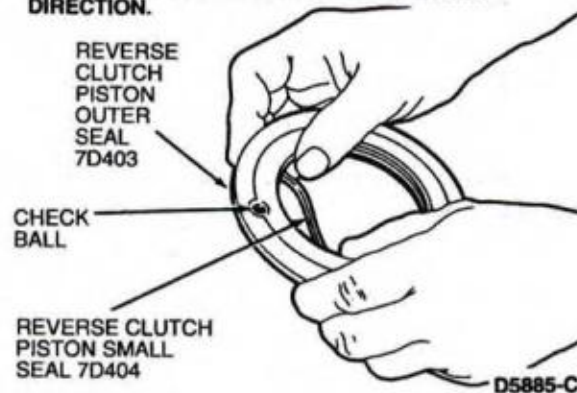

2. Install reverse clutch piston as follows:
- Install Reverse Clutch Inner Seal Protector T80L-77403-B on the clutch hub and Reverse Clutch Outer Seal Protector T80L-77403-A over the reverse clutch piston.

## DISASSEMBLY AND ASSEMBLY OF SUBASSEMBLIES (Continued)

- b. Position reverse clutch piston and push it to the bottom of the reverse clutch drum using even thumb pressure.

REVERSE CLUTCH  
SEAL PROTECTOR  
(INNER)  
T80L-77403-B

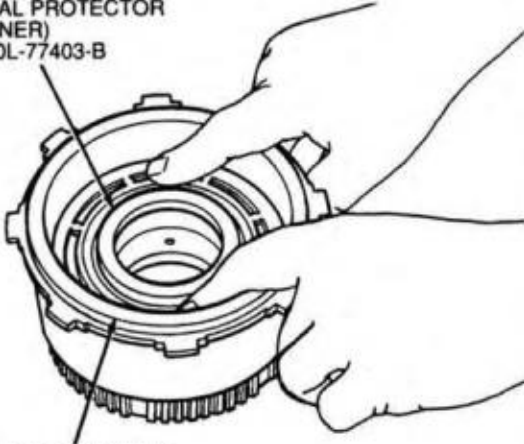

REVERSE CLUTCH  
SEAL PROTECTOR  
(OUTER) T80L-77403-A

D10249-A

3. Install reverse clutch piston spring pressure ring and reverse clutch piston spring. The dished side of reverse clutch piston spring must face toward the reverse clutch piston.

REVERSE CLUTCH  
PISTON SPRING  
PRESSURE RING  
7D256

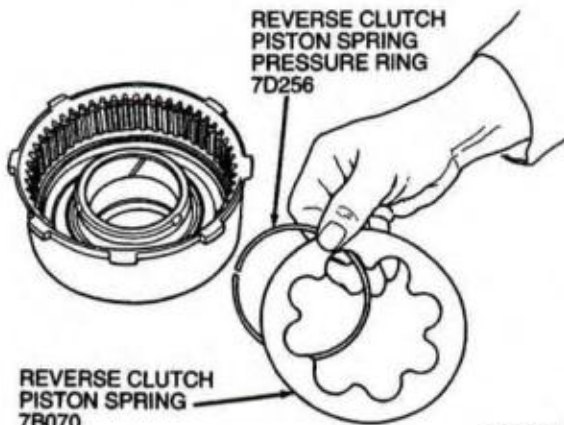

REVERSE CLUTCH  
PISTON SPRING  
7B070

D3227-D

4. Install reverse clutch piston spring pressure ring and retaining ring (with points down) using Reverse Clutch Spring Compressor T80L-77405-A and Clutch Spring Compressor T65L-77515-A.

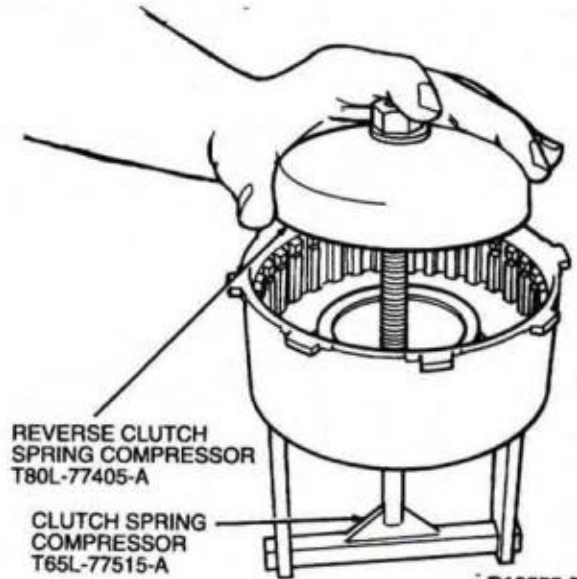

REVERSE CLUTCH  
SPRING COMPRESSOR  
T80L-77405-A

CLUTCH SPRING  
COMPRESSOR  
T65L-77515-A

D10555-B

5. Install front clutch pressure plate (7B066), clutch pack and rear clutch pressure plate. Position the stepped side of front clutch pressure plate down with flat side toward clutch pack and rear clutch pressure plate flat side toward clutch pack.

REAR PRESSURE  
PLATE  
7B066

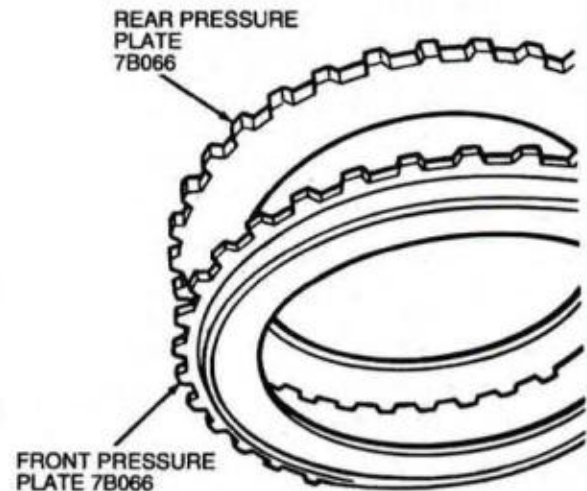

FRONT PRESSURE  
PLATE 7B066

D10128-B

## DISASSEMBLY AND ASSEMBLY OF SUBASSEMBLIES (Continued)

6. Install clutch pack clutch pressure plate retainer snap ring and check the clearance between the clutch pressure plate retainer snap ring and the clutch pressure plate using a feeler gauge. Clutch pressure plate should be held downward as clearance is checked using Dial Indicator with Bracketry TOOL-4201-C or equivalent.

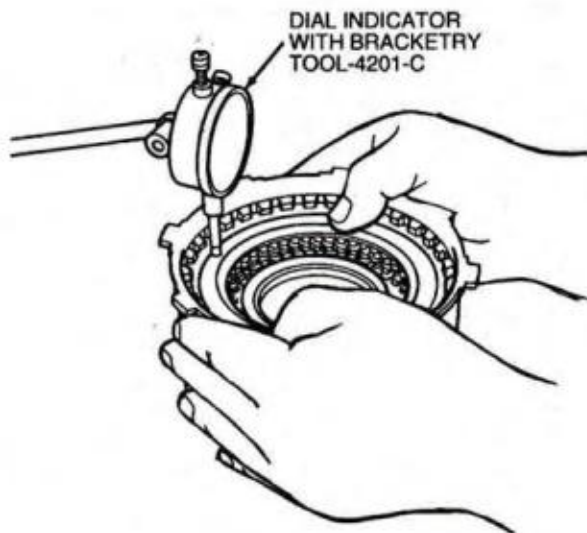

D10557-C

The clearance should be:

Four plate assembly

- 1.01-1.524 mm (0.040-0.060 inch)

If clearance is not within specification, install correct size retaining ring and check clearance. Selective retaining rings are available in the following thicknesses:

Selective Retaining Rings
1.52-1.62 mm (0.060-0.064 inch)
1.87-1.98 mm (0.074-0.078 inch)
2.23-2.33 mm (0.088-0.092 inch)
2.59-2.69 mm (0.102-0.106 inch)

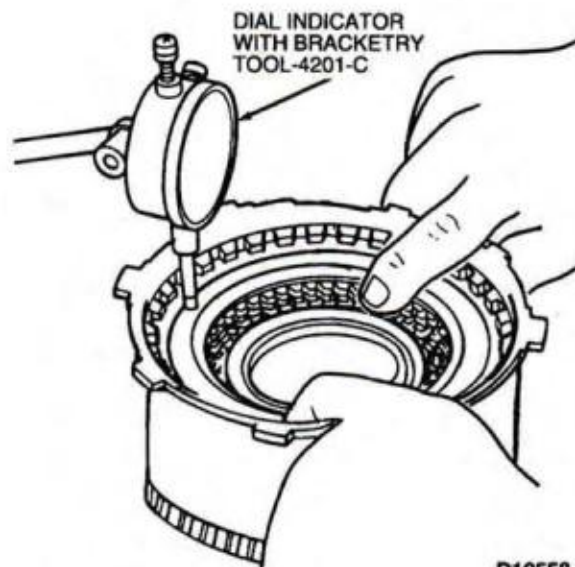

D10558-B

7. Check clutch for proper operation using Rubber-Tipped Air Gun D93L-7000-A or equivalent. The clutch should be heard and felt to work smoothly and without leakage.

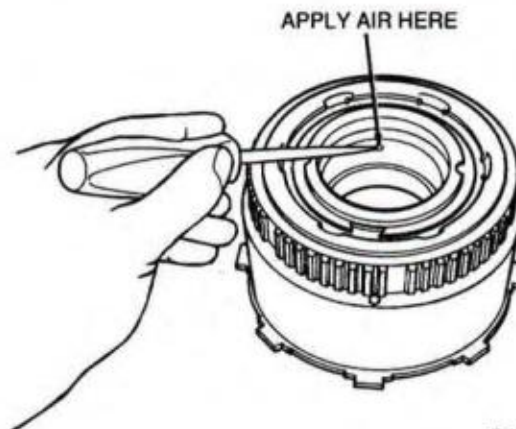

D8935-A

## DISASSEMBLY AND ASSEMBLY OF SUBASSEMBLIES (Continued)

### Forward Clutch Cylinder

#### Disassembled View

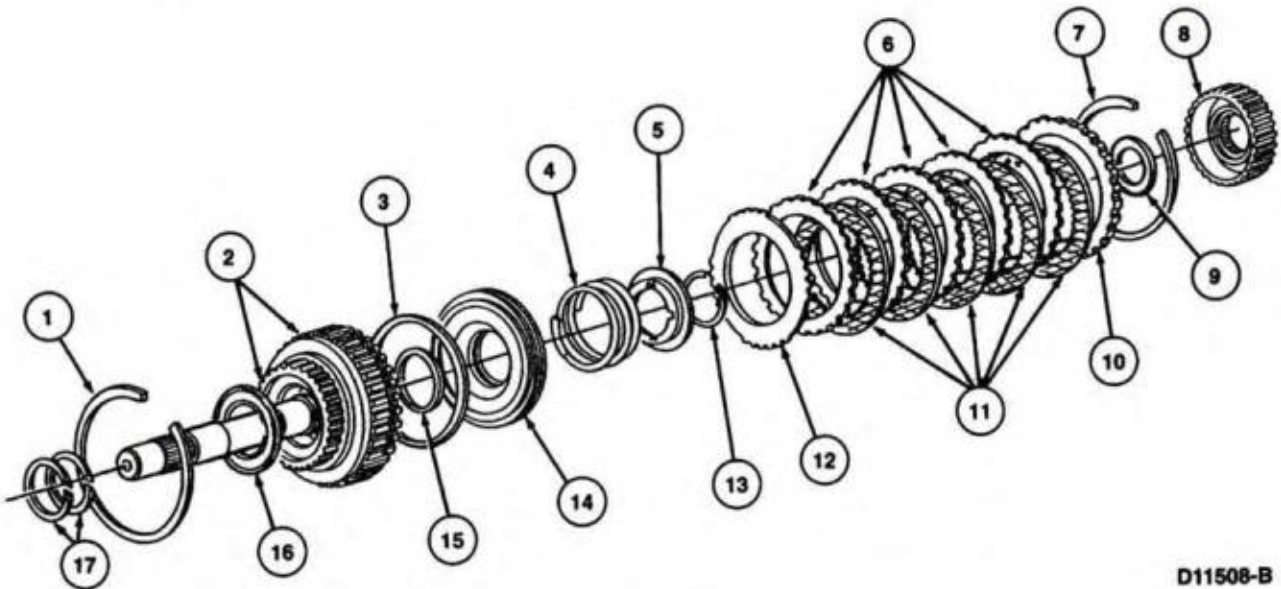

D11508-B

Item	Part Number	Description
1	7D483	Reverse Clutch Pressure Plate Retainer Snap Ring
2	7F207	Forward Clutch Cylinder and Shaft
3	7A548	Outer Seal
4	7A480	Return Spring
5	7A527	Forward Clutch Piston Spring Retainer
6	7B442	Forward Clutch External Spline Clutch Plate
7	7D483	Clutch Pressure Plate Retainer Snap Ring
8	7B067	Forward Clutch Hub

(Continued)

Item	Part Number	Description
9	7F231	Forward Clutch Hub Front Bearing, No. 3
10	7B066	Clutch Pressure Plate
11	7B164	Forward Clutch Internal Spline (Friction) Plates
12	7E085	Forward Clutch Pressure Spring
13	388099-S	Retaining Ring
14	7A262	Clutch Piston
15	7C099	Forward Clutch Inner Seal
16	7A166	Forward Clutch Bearing No. 2
17	7B497	Input Shaft Seal (2 Req'd)

### Disassembly

#### SPECIAL SERVICE TOOL(S) REQUIRED

Description	Tool Number
Clutch Spring Compressor	T65L-77515-A
Direct Clutch Spring Compressor	T81P-70235-A
Forward Clutch Lip Seal Protector (Inner)	T80L-77140-A
Lip Seal Protector (Outer)	T68P-7D158-A

## DISASSEMBLY AND ASSEMBLY OF SUBASSEMBLIES (Continued)

1. **NOTE:** Forward clutch hub may remain in shell during disassembly.  
Remove forward clutch hub and No. 3 forward clutch hub front bearing (7F231), if not already removed.

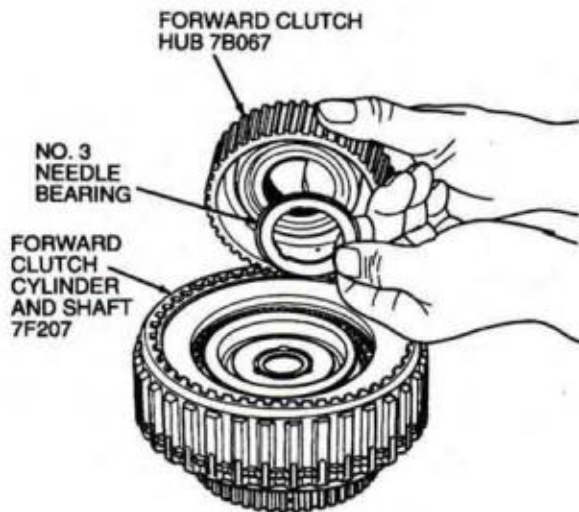

D3832-D

2. **NOTE:** To aid handling, clutch may be set in the extension housing (7A039) or a 51 mm (2 inch) diameter hole may be cut in the work bench.  
Remove clutch pack clutch pressure plate retainer snap ring (7D483).

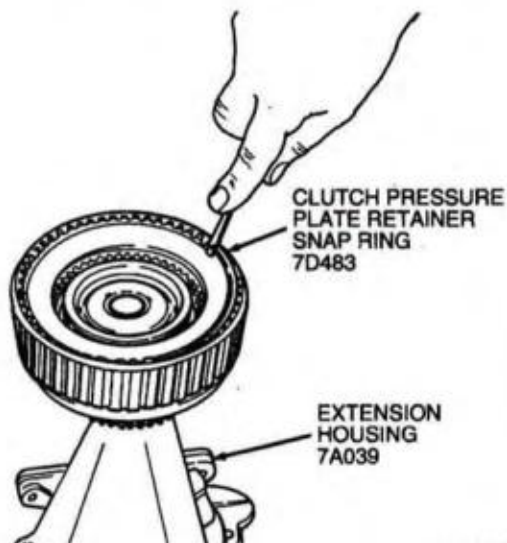

D3236-E

3. Remove clutch pack, clutch pressure plate (7B066) and forward clutch pressure spring.

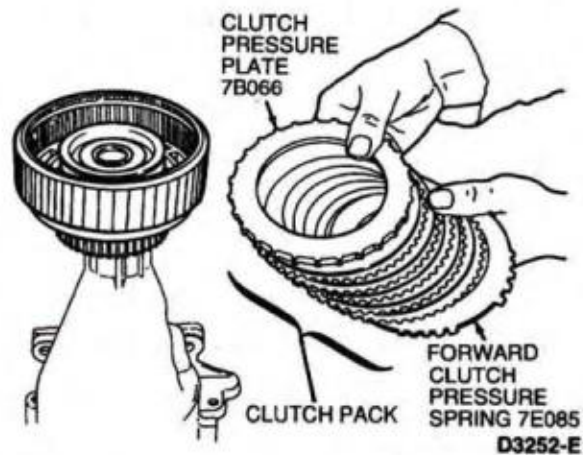

D3252-E

4. Compress clutch support and spring using Direct Clutch Spring Compressor T81P-70235-A.

Place into a shop arbor press and apply only enough pressure to release spring tension on the snap ring.

Remove snap ring and slowly release the press to remove spring compressor.

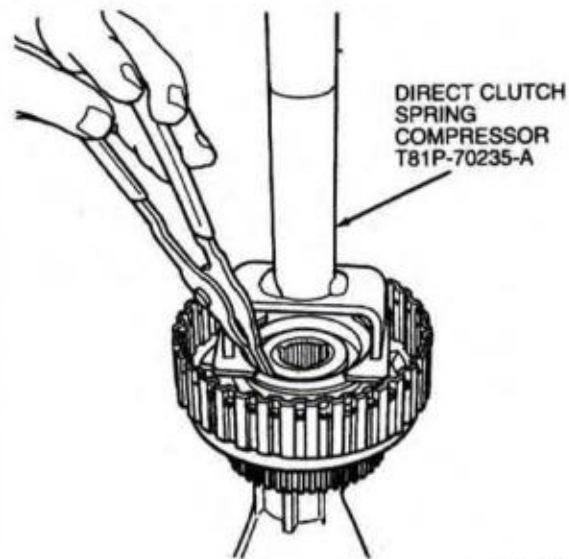

D10243-C

5. **NOTE:** Air pressure may be required to remove clutch piston (7A262).

Remove clutch piston spring retainer (7A527), return spring and clutch piston.

## DISASSEMBLY AND ASSEMBLY OF SUBASSEMBLIES (Continued)

6. Remove piston direct clutch inner seal (7C099) and outer piston seals.

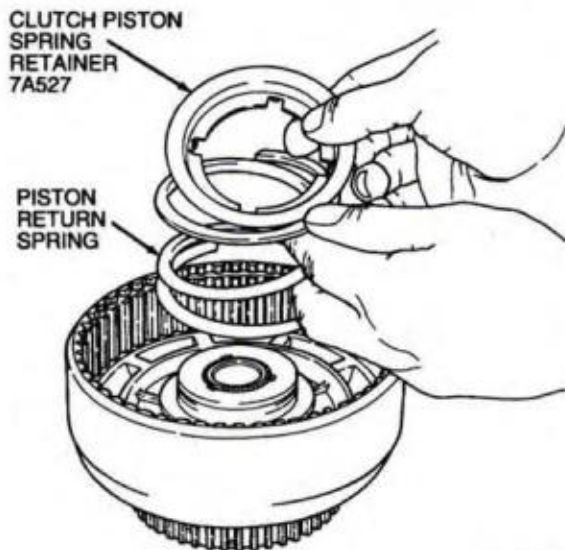

D3238-C

7. NOTE: Make sure input shaft Teflon® seals are not damaged.  
NOTE: Solid shaft seals may be replaced with scarf-cut seals for service.  
Remove seals from forward clutch cylinder and shaft (7F207).

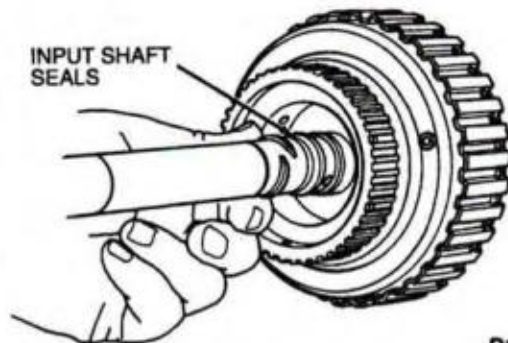

D10242-B

8. Make sure check ball in clutch cylinder is free and clean. Check for proper seating.

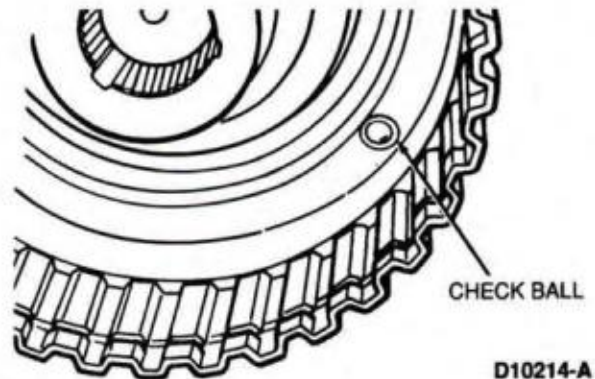

D10214-A

### Assembly

1. NOTE: Coat piston seals and clutch drum sealing area with petroleum jelly.  
Install new seals on clutch piston. Note direction of the sealing lip before installation.

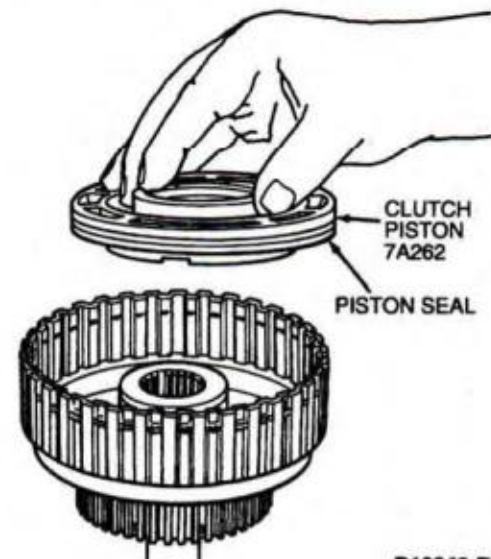

D10240-B

2. Install clutch piston as follows:
- Install Forward Clutch Lip Seal Protector (Inner) T80L-77140-A over clutch cylinder hub.

## DISASSEMBLY AND ASSEMBLY OF SUBASSEMBLIES (Continued)

- b. Install clutch piston in Forward Clutch Lip Seal Protector, T68P-7D158-A.

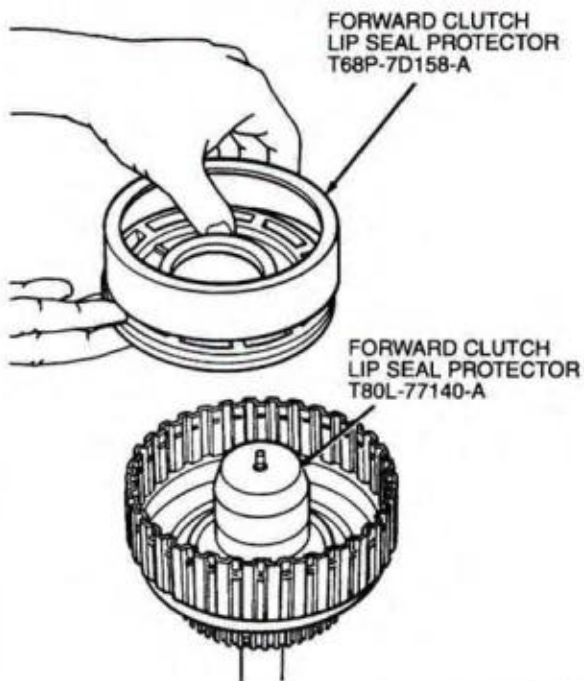

AD0501-A

3. Position seal protector and clutch piston in forward clutch cylinder and shaft. Push clutch piston to the bottom of the forward clutch cylinder and shaft using even thumb pressure. Remove seal protectors.

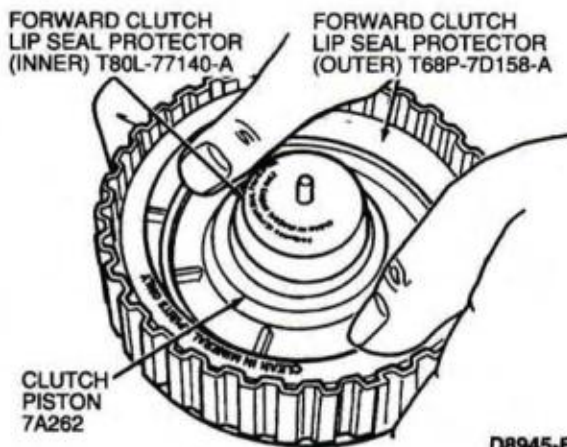

D8945-B

4. Install piston return spring and clutch piston spring retainer.

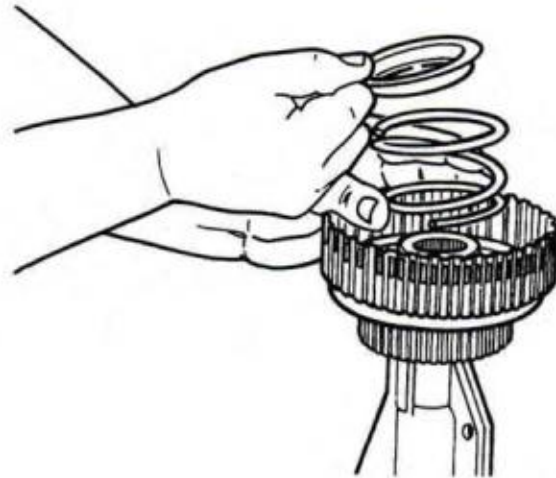

D10559-A

5. Compress piston return spring using Direct Clutch Spring Compressor T81P-70235-A. Compress clutch piston only enough to allow clearance to install snap ring.

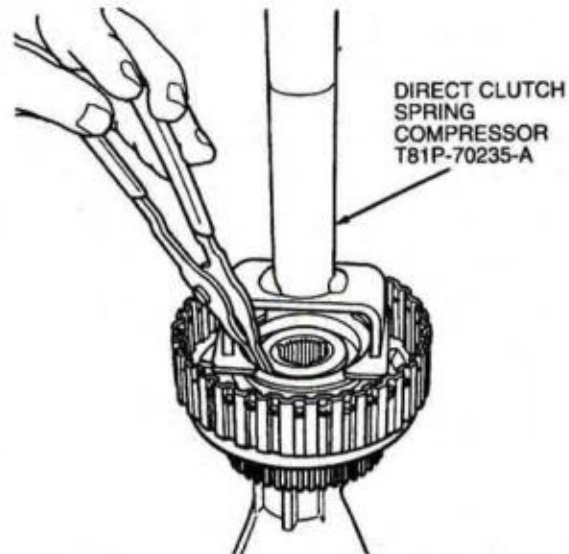

D10243-C

6. Install clutch pack in the following order:
- forward clutch pressure spring
  - clutch pack

**DISASSEMBLY AND ASSEMBLY OF SUBASSEMBLIES (Continued)**

c. clutch pressure plate

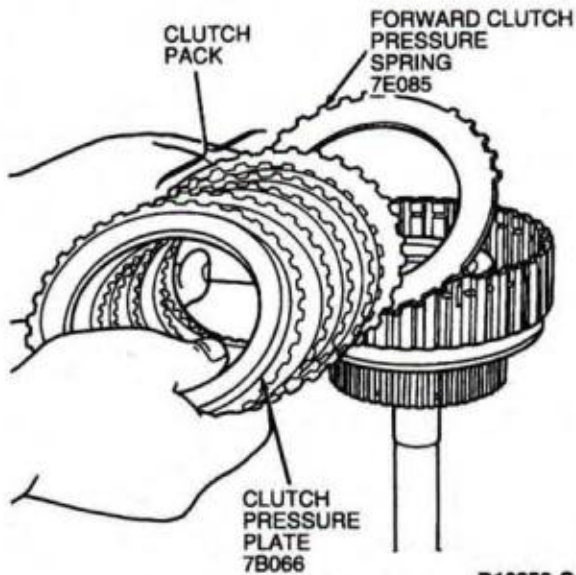

D10252-C

7. Install clutch pack clutch pressure plate retainer snap ring and check the clearance between the clutch pressure plate retainer snap ring and clutch pressure plate using Dial Indicator with Bracketry TOOL-4201-C or equivalent.

Clutch pressure plate should be held downward as the clearance is checked.

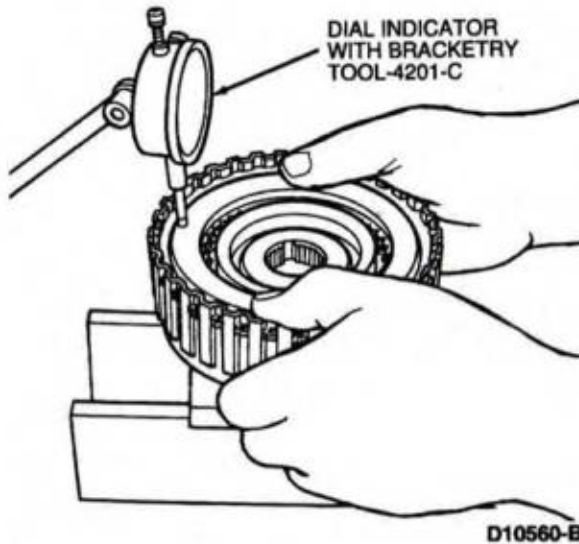

D10560-B

DIAL INDICATOR WITH BRACKETRY TOOL-4201-C

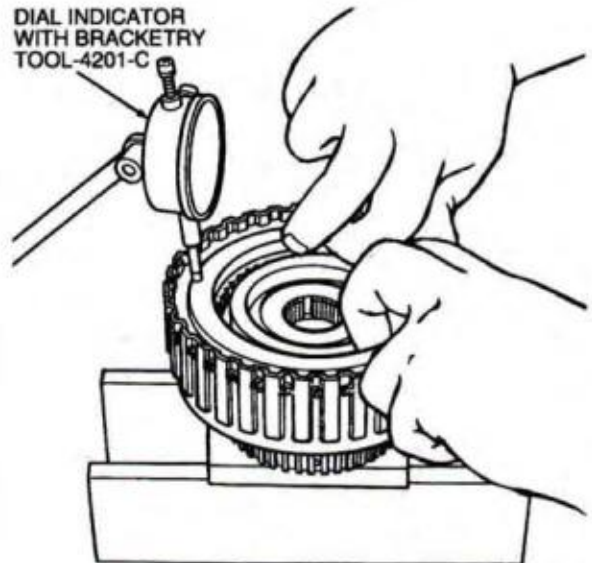

D10561-B

If the clearance is not within specification, install the correct size retaining ring and recheck the clearance. Selective retaining rings are available in the following thicknesses:

Selective Retaining Ring
1.52-1.62 mm (0.060-0.064 inch)
1.87-1.98 mm (0.074-0.078 inch)
2.23-2.69 mm (0.088-0.092 inch)
2.59-2.69 mm (0.102-0.106 inch)

8. **NOTE:** Scarf-cut seals must be installed with mating surfaces as shown. Install two scarf-cut seals on the forward clutch cylinder and shaft if original seals are damaged or missing.



CORRECT



INCORRECT

D10657-A

## DISASSEMBLY AND ASSEMBLY OF SUBASSEMBLIES (Continued)

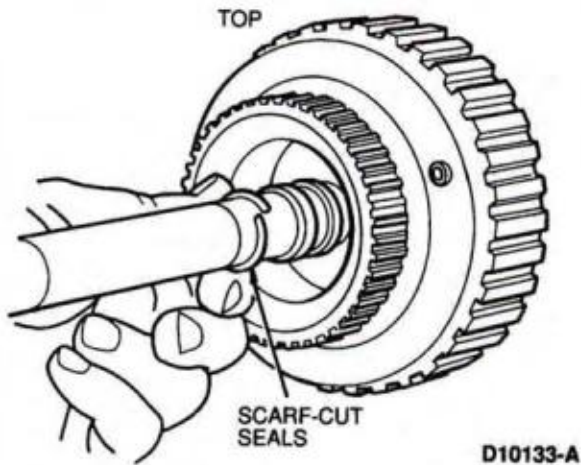

The clearance should be:

- 1.27-2.26 mm (0.50-0.089 inch)

9. Install No. 3 forward clutch hub front bearing. Install forward clutch hub into forward clutch cylinder and shaft. Make sure forward clutch hub is against No. 3 forward clutch hub front bearing.

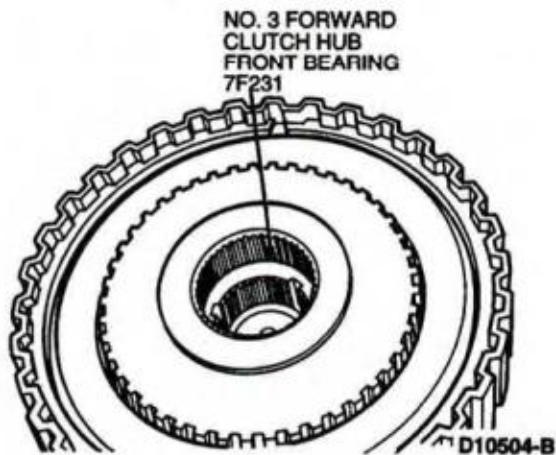

## Planetary Gear Support Assembly and Planetary Low One-Way Clutch Disassembly

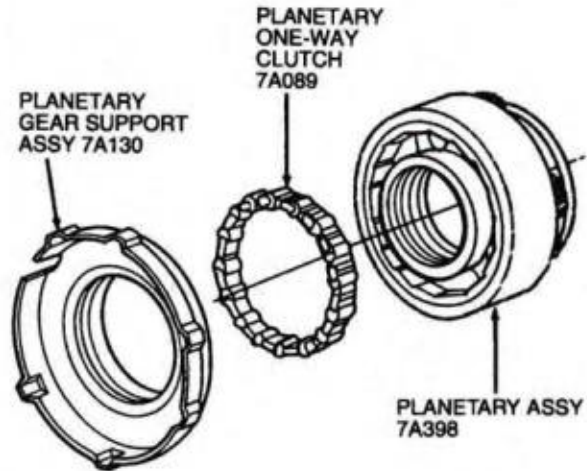

AD0502-A

1. Remove planetary gear support assembly from forward planetary assembly. Rotate the planetary gear support assembly counterclockwise and lift.

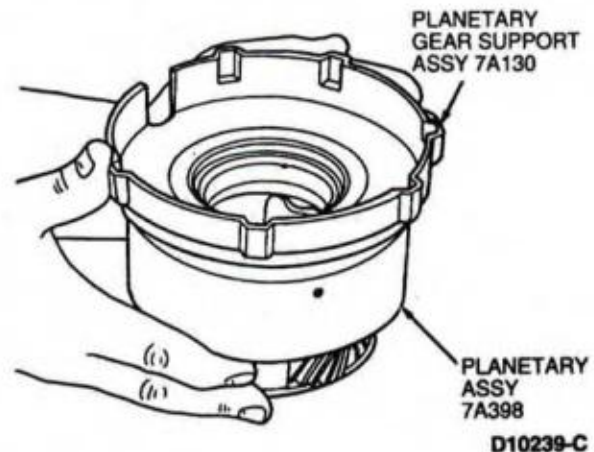

D10239-C

## DISASSEMBLY AND ASSEMBLY OF SUBASSEMBLIES (Continued)

2. Carefully remove planetary one-way clutch from forward planetary assembly.

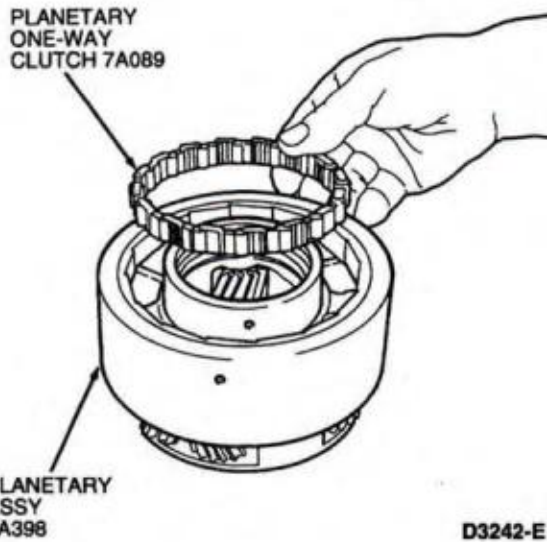

### Assembly

1. Inspect clutch outer race, inner race, band surface, pinion gears, bearings and thrust washer for roughness.
- Inspect planet support bushing for roughness.
- Inspect one-way clutch (7A089), rollers and springs for damaged rollers and broken springs.

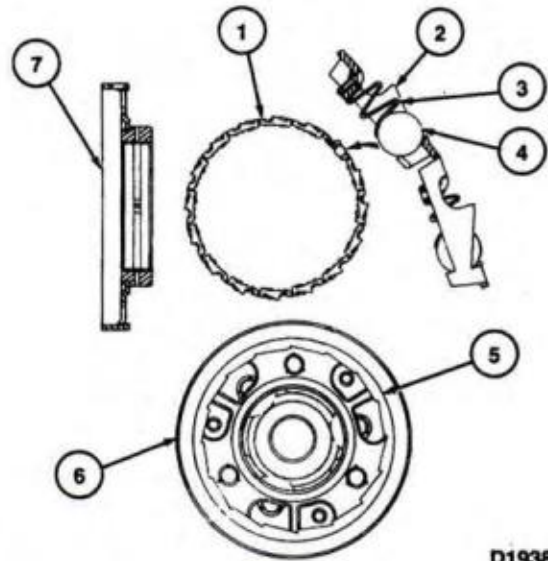

Item	Part Number	Description
1	7A089	Planetary One-Way Clutch
2	—	Cage (Part of 7A089)
3	—	Spring (Part of 7A089)
4	—	Roller (Part of 7A089)
5	—	"Cam Type" Clutch Race (Part of 7A398)
6	—	Planetary Carrier (Part of 7A398)
7	7A130	Planet Support

2. Install one-way clutch in forward planetary assembly.
3. Install planetary gear support assembly into one-way clutch by rotating the planetary gear support assembly counterclockwise.
- Lubricate clutch races and clutch assembly with petroleum jelly to aid in assembly.

## DISASSEMBLY AND ASSEMBLY OF SUBASSEMBLIES (Continued)

### Reverse Sun Gear Assembly

#### Disassembly

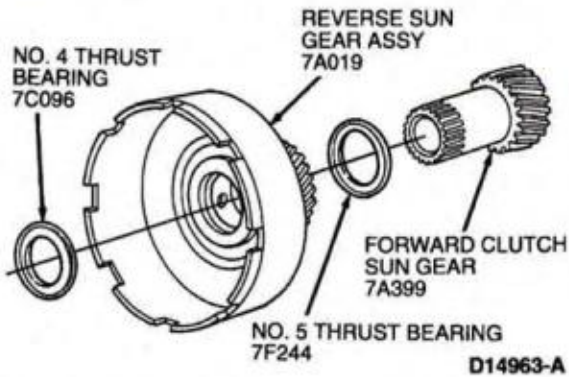

1. Remove the No. 4 thrust bearing (7C096) from reverse sun gear assembly.

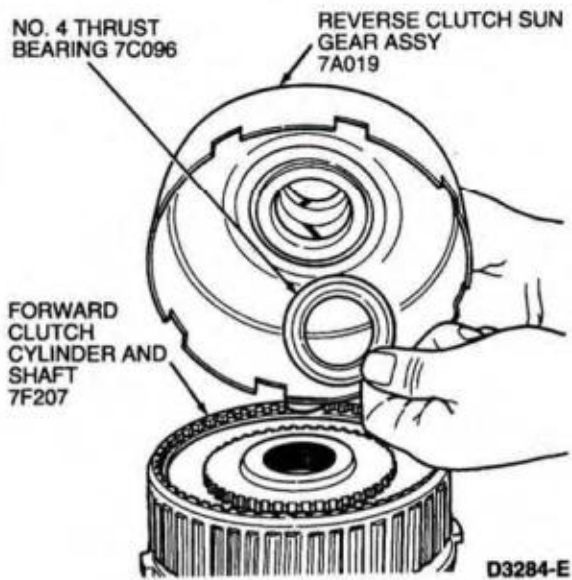

2. **NOTE:** The forward clutch sun gear and reverse sun gear assembly is assembled as part of the transmission assembly procedure.  
Remove forward clutch sun gear and No. 5 thrust bearing from reverse sun gear assembly.

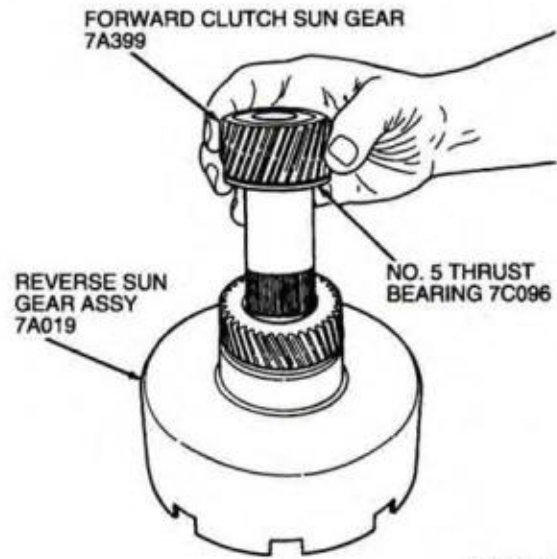

**DISASSEMBLY AND ASSEMBLY OF SUBASSEMBLIES (Continued)**

**Output Shaft and Direct Clutch Cylinder**

Disassembled View

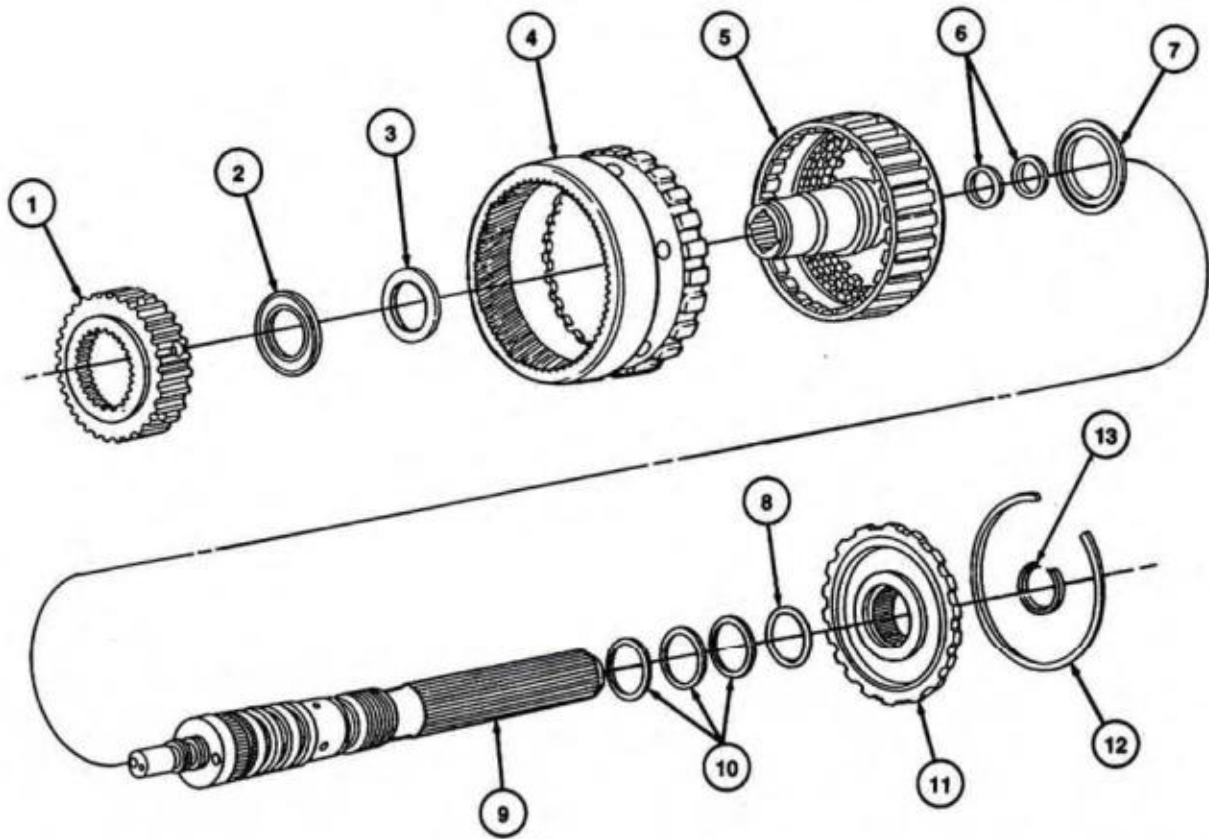

AD0503-A

Item	Part Number	Description
1	7F236	Direct Clutch Hub
2	7F243	Direct Clutch Inner Bearing No. 7
3	7F237	Direct Clutch Inner Bearing Support
4	7A153	Ring Gear
5	7F283	Direct Clutch Cylinder
6	7F274	Output Shaft to Direct Clutch Cylinder Seal (2 Req'd)

(Continued)

Item	Part Number	Description
7	7F240	Direct Clutch Bearing and Race No. 8
8	87054-S94	Seal (Piloted Output Shaft Only)
9	7060	Output Shaft
10	7F273	Output Shaft to Case Seal (3 Req'd)
11	7D164	Output Shaft Hub
12	7064	Snap Ring
13	97713-S	Snap Ring

**DISASSEMBLY AND ASSEMBLY OF SUBASSEMBLIES (Continued)**

**Disassembly**

1. Remove snap ring (7064) retaining the output shaft hub (7D164) to ring gear (7A153).

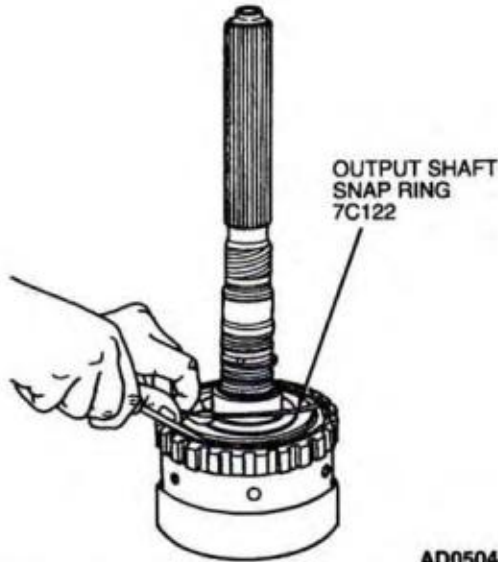

2. Separate output shaft (7060) from ring gear.

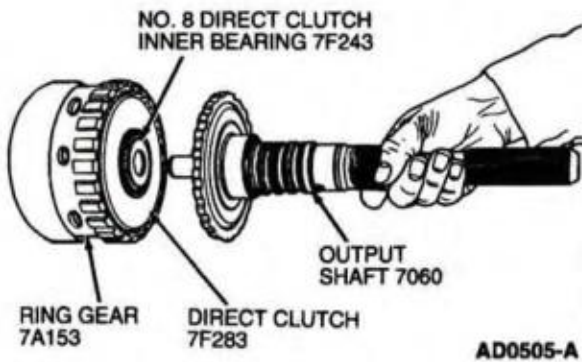

3. Remove snap ring retaining output shaft hub. Slide output shaft hub off rear of output shaft.

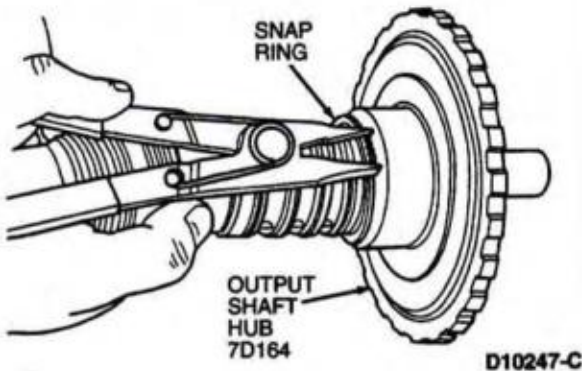

4. NOTE: The illustration shows the correct locations for output shaft to case seals (7F273). Remove three output shaft to case seals.

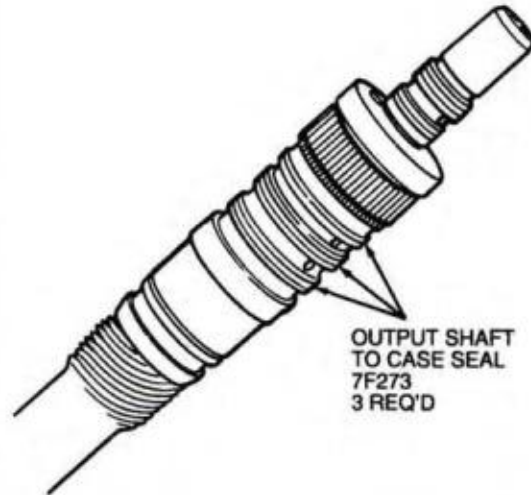

5. Remove two output shaft to direct clutch cylinder seals (7F274) from the output shaft. Note the direction of the output shaft to direct clutch cylinder seals.

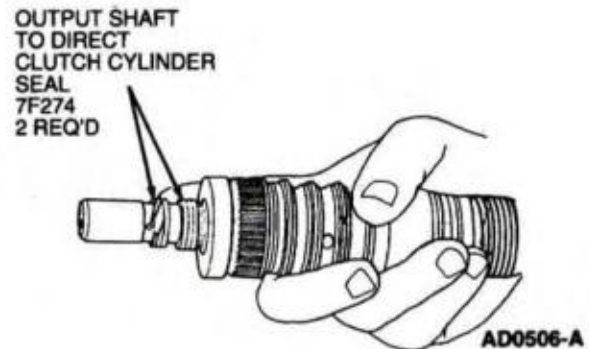

ProCarManuals.com

**DISASSEMBLY AND ASSEMBLY OF SUBASSEMBLIES (Continued)**

**Direct Clutch Cylinder**

Disassembled View

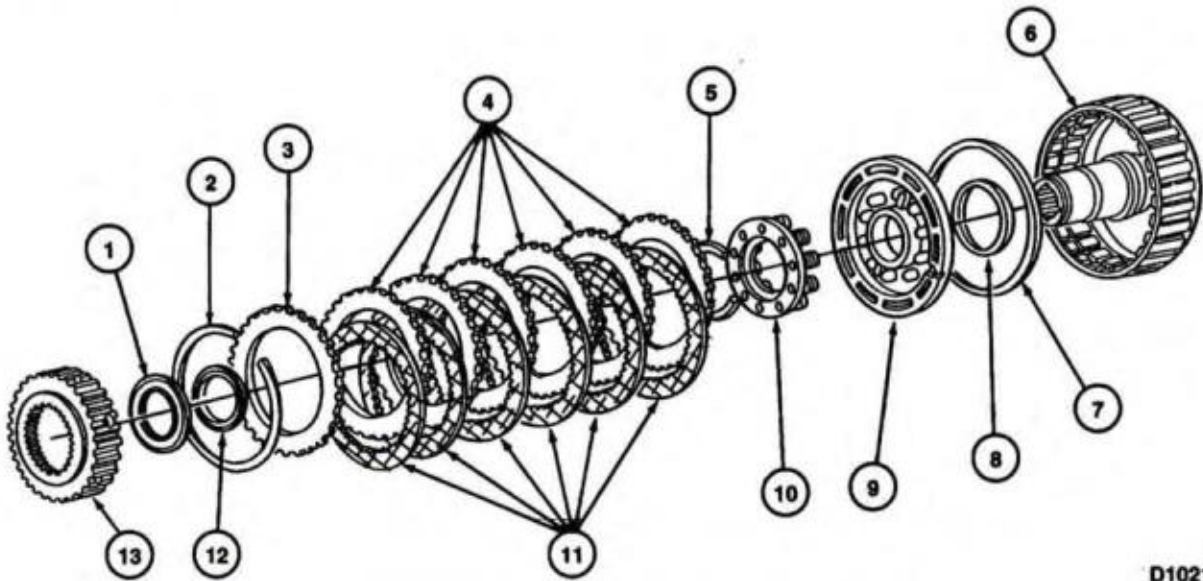

D10216-D

Item	Part Number	Description
1	7F243	Direct Clutch Inner Bearing No. 7
2	7D483	Clutch Pressure Plate Retainer Snap Ring
3	7B066	Clutch Pressure Plate
4	7B442	Direct Clutch External Spline Clutch Plate
5	388104-S	Retaining Ring
6	7F283	Direct Clutch Cylinder

(Continued)

Item	Part Number	Description
7	7A233	Outer Seal
8	7C099	Direct Clutch Inner Seal
9	7A262	Clutch Piston
10	7F235	Direct Clutch Retainer and Spring Assembly
11	7B164	Direct Clutch Internal Spline (Friction) Plates
12	7F237	Direct Clutch Inner Bearing Support
13	7F236	Direct Clutch Hub

**Disassembly**

**SPECIAL SERVICE TOOL(S) REQUIRED**

Description	Tool Number
Clutch Spring Compressor	T65L-77515-A
Direct Clutch Inner Lip Seal Protector	T80L-77234-A
Direct Clutch Outer Lip Seal Protector	T80L-77254-A

## DISASSEMBLY AND ASSEMBLY OF SUBASSEMBLIES (Continued)

1. After removing direct clutch hub, remove No. 7 direct clutch inner bearing (7F243) and direct clutch inner bearing support.

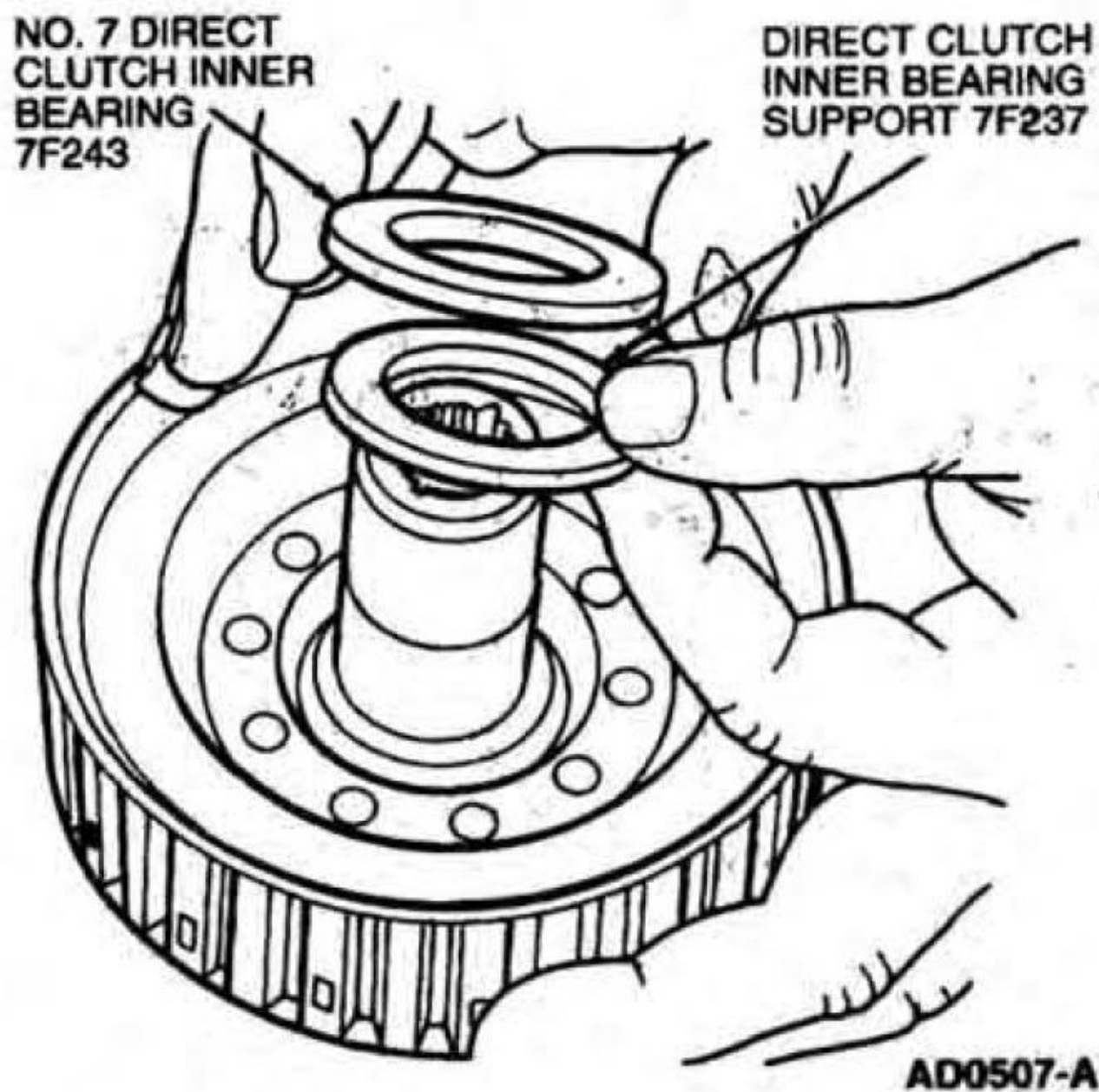

2. Remove clutch pressure plate retainer snap ring (7D483). Remove and inspect clutch pack. Note the relation of clutch pressure plates (7B066) for assembly.

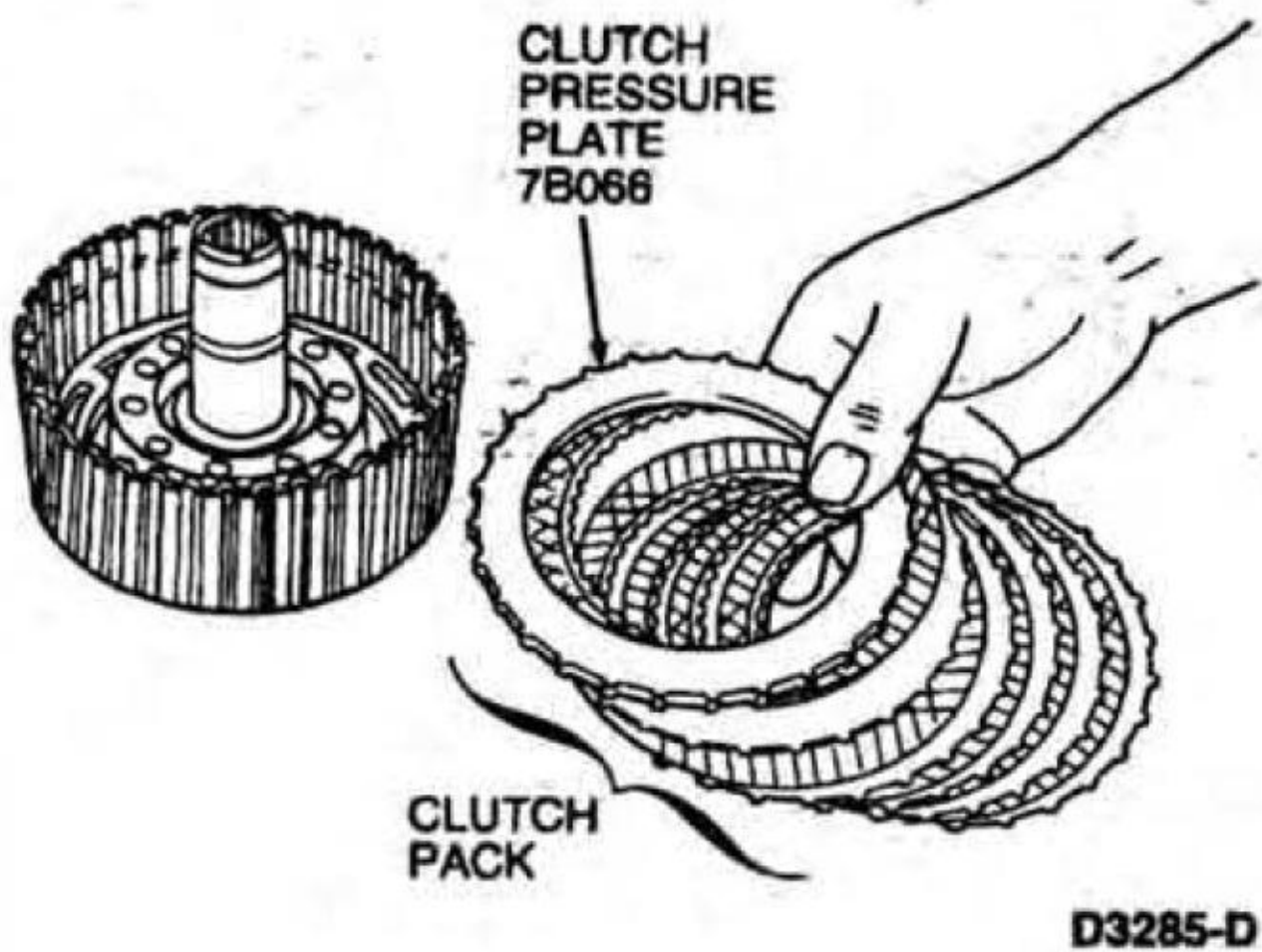

3. Using Clutch Spring Compressor T65L-77515-A compress the direct clutch support and spring (7F235). Remove piston retaining ring using expanding-type snap-ring pliers.

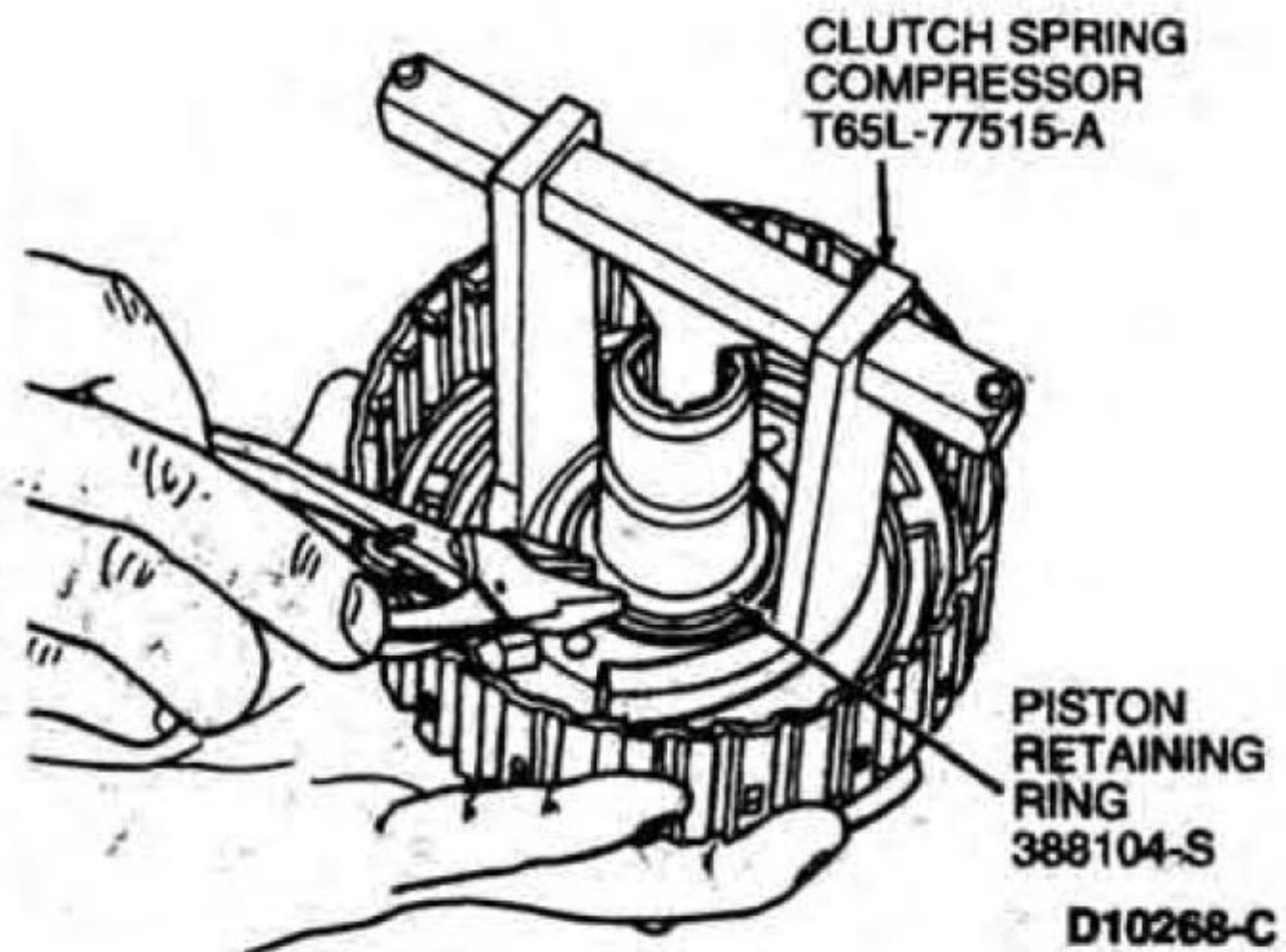

4. **NOTE:** Use air pressure if necessary to remove clutch piston (7A262). Remove direct clutch support and spring and clutch piston from direct clutch cylinder.

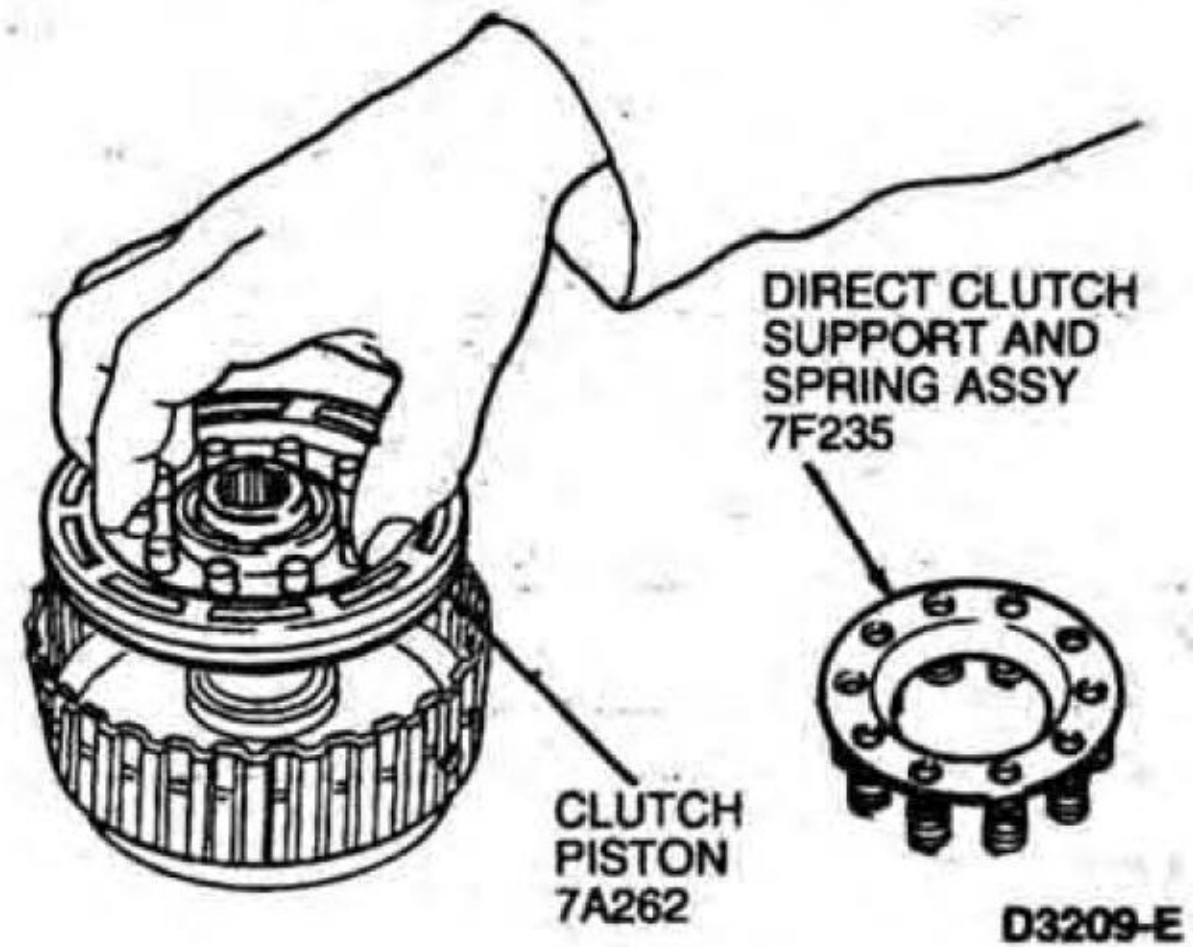

## DISASSEMBLY AND ASSEMBLY OF SUBASSEMBLIES (Continued)

5. Remove direct clutch inner seal (7C099) from direct clutch and outer seal from clutch piston. Verify presence of check ball and that it moves freely.

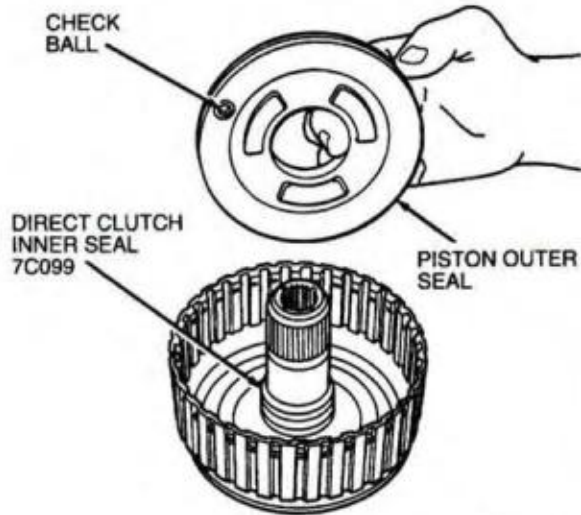

### Assembly

1. NOTE: Lubricate direct clutch inner seal and seal protector with petroleum jelly. Install direct clutch inner seal on direct clutch as follows:
- Position Direct Clutch Inner Lip Seal Protector T80L-77234-A over direct clutch cylinder.
  - Position direct clutch inner seal over protector tool with the sealing lip facing down.

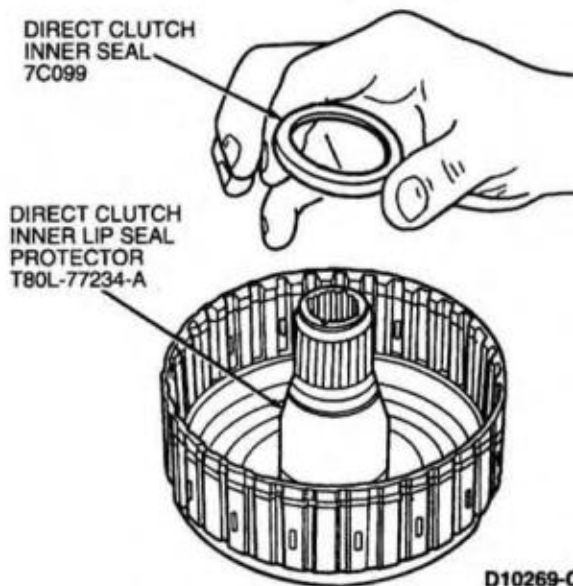

2. NOTE: Coat direct clutch inner seal and outer piston seals, clutch cylinder sealing area and piston inner sealing area with petroleum jelly. Install clutch piston outer seal. Note direction of sealing lip before installation. The lip should point toward bottom of clutch cylinder.



3. Install clutch piston as follows:
- Install clutch piston in Direct Clutch Outer Lip Seal Protector T80L-77254-A.

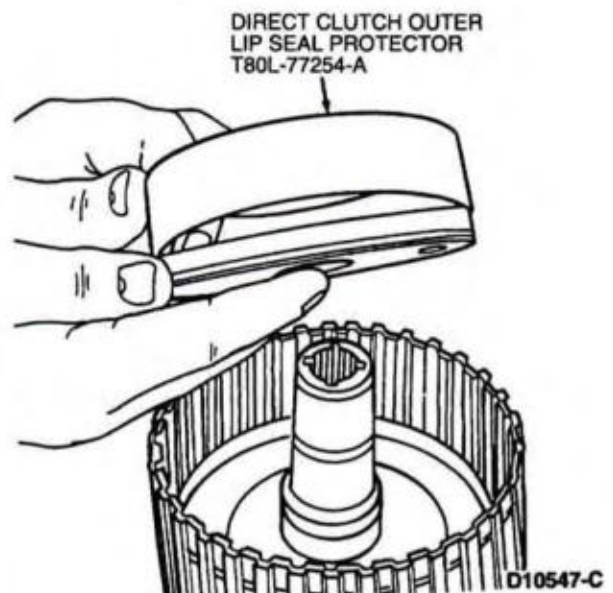

## DISASSEMBLY AND ASSEMBLY OF SUBASSEMBLIES (Continued)

- b. Position tool in the direct clutch and push the clutch piston to the bottom of the direct clutch cylinder using even thumb pressure.

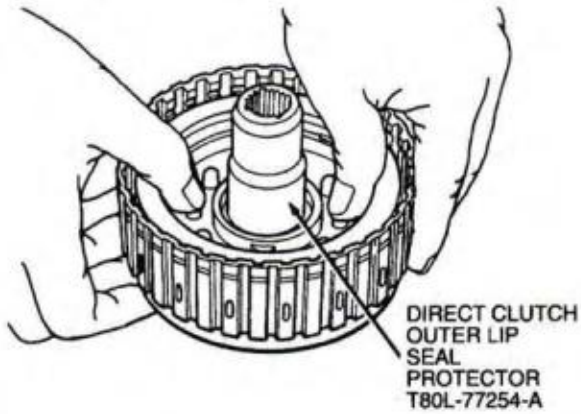

D10273-B

4. Install direct clutch support and spring and retaining ring using Clutch Spring Compressor T65L-77515-A.

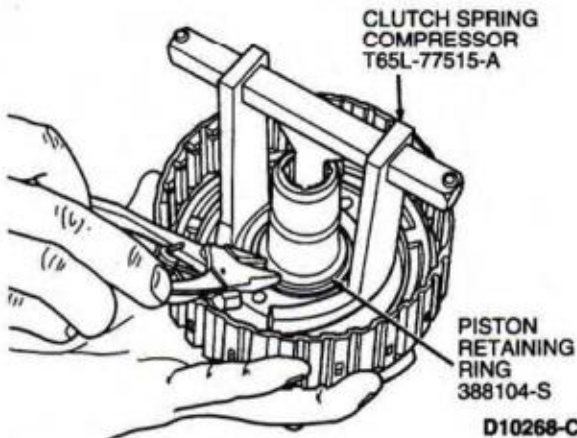

D10268-C

5. Install clutch pack and clutch pressure plate.

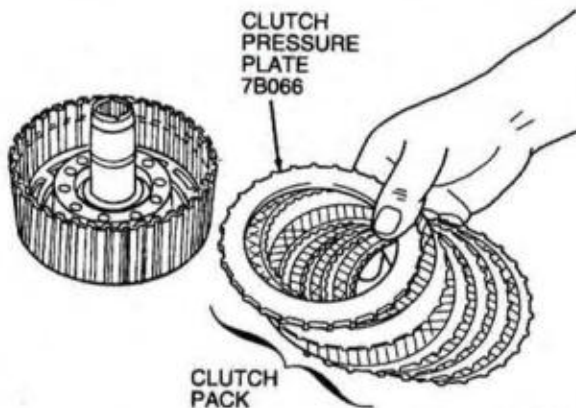

D3285-D

6. NOTE: TOOL-4201-C or equivalent may also be used for clearance check.

With clutch pressure plate retainer snap ring installed, check clearance between clutch pressure plate retainer snap ring and clutch pressure plate using a feeler gauge.

Clutch pressure plate should be held downward as the clearance is checked.

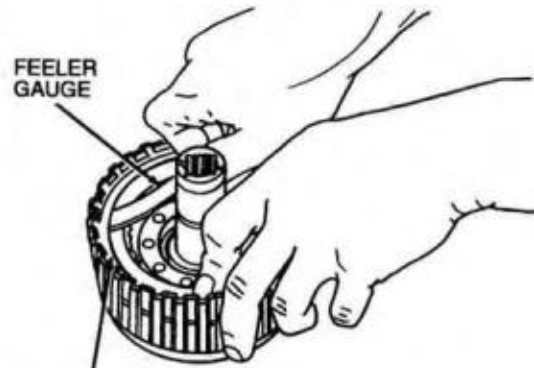

CLUTCH PRESSURE PLATE RETAINER RING 7D483

D3274-C

7. The clearance should be:

Engine	Number of Plates	mm	Inch
3.8L	5 Plate	1.27-1.80	0.050-0.071
4.6L	6 Plate	1.57-2.16	0.062-0.085

— If the clearance is not within limits, install the correct size retaining ring and check the clearance. Selective retaining rings are available in the following thicknesses:

Selective Retaining Rings
1.27-1.37 mm (0.050-0.054 inch)
1.62-1.72 mm (0.064-0.068 inch)
1.98-2.08 mm (0.078-0.082 inch)
2.33-2.43 mm (0.092-0.096 inch)

**DISASSEMBLY AND ASSEMBLY OF SUBASSEMBLIES (Continued)**

8. Install No. 7 direct clutch inner bearing support (with counter bore down) and No. 7 direct clutch inner bearing (black side up toward rear clutch hub).

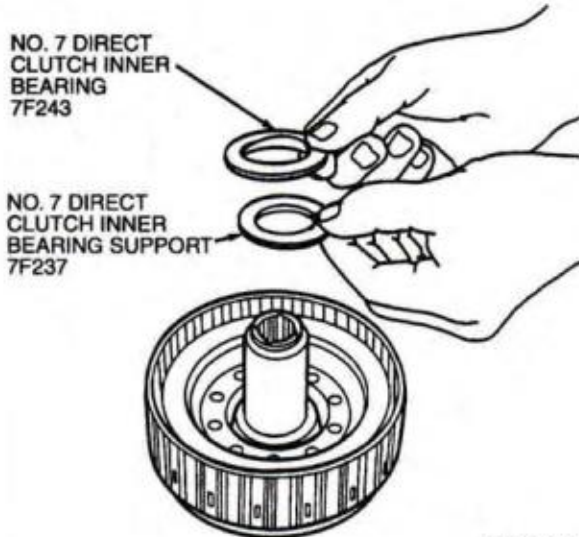

9. Install direct clutch hub (7F236).

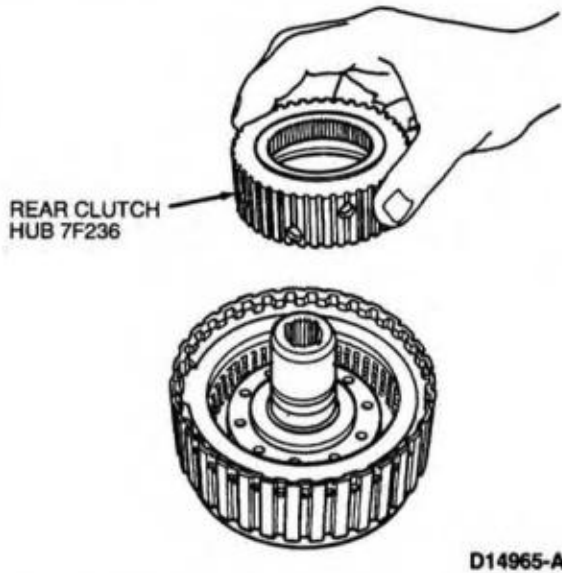

10. Install two output shaft to direct clutch cylinder seals (7F274). Make sure output shaft to direct clutch cylinder seals are properly lapped.



OUTPUT SHAFT TO DIRECT CLUTCH CYLINDER SEALS 7F274 2 REQ'D

D10548-B

11. Install output shaft hub (7D 164). Install snap ring (7064).

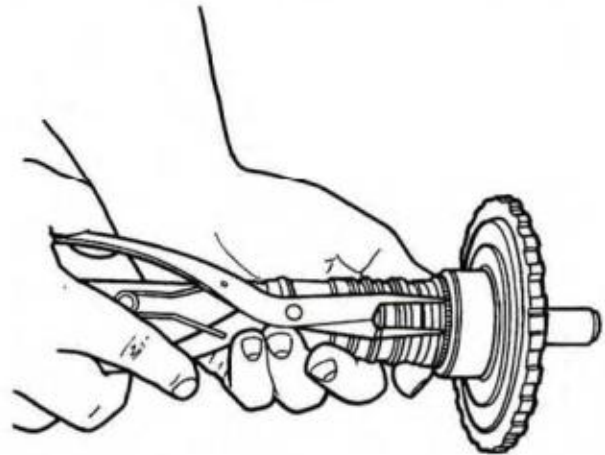

D10549-A

12. NOTE: Make sure output shaft to case seals (7F273) are lapped properly. Install three output shaft to case seals and output shaft O-ring seal.

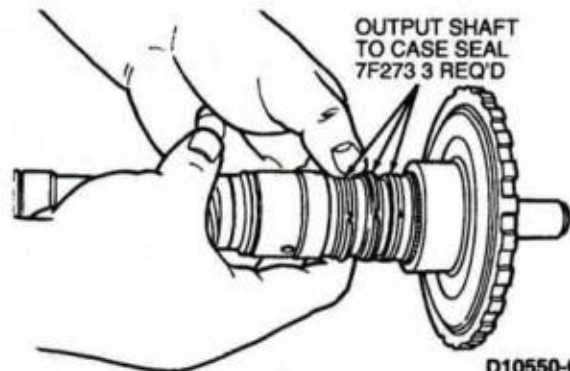

OUTPUT SHAFT TO CASE SEAL 7F273 3 REQ'D

D10550-C

## DISASSEMBLY AND ASSEMBLY OF SUBASSEMBLIES (Continued)

13. Install No. 8 direct clutch hub bearing and race (7F240) on direct clutch cylinder.

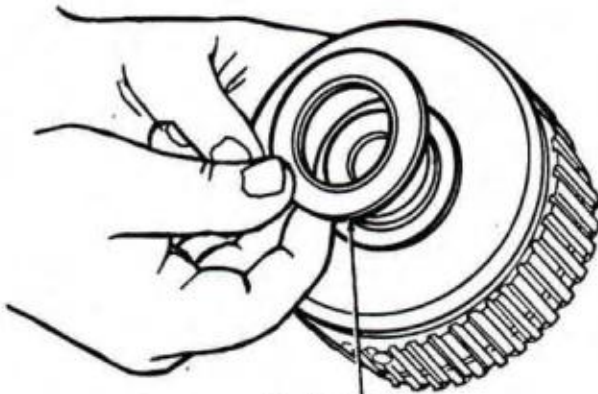

NO. 8 DIRECT CLUTCH HUB BEARING AND RACE 7F240

D10551-D

14. NOTE: Direct clutch cylinder may be installed after ring gear (7A153) is installed to output shaft hub.

Install direct clutch cylinder on output shaft (7060).

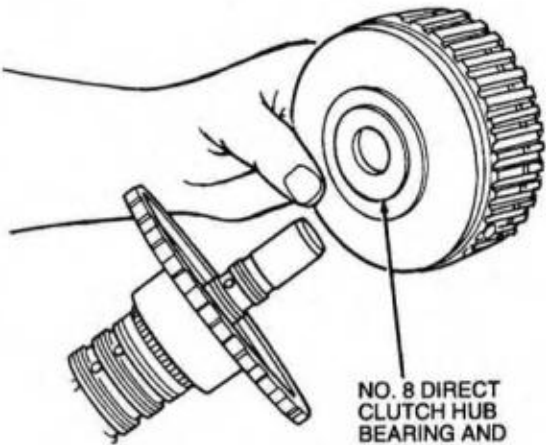

NO. 8 DIRECT CLUTCH HUB BEARING AND RACE 7F240

D10552-D

15. Install ring gear and snap ring on output shaft.

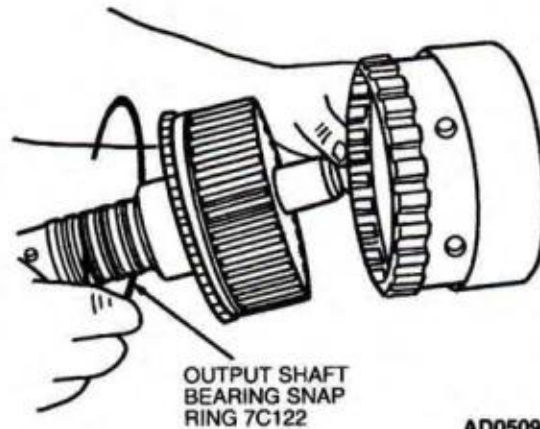

OUTPUT SHAFT BEARING SNAP RING 7C122

AD0509-A

16. The following components may be installed as an assembly:

- intermediate one-way clutch
- reverse clutch
- forward clutch

17. Install reverse clutch assembly on forward clutch assembly.

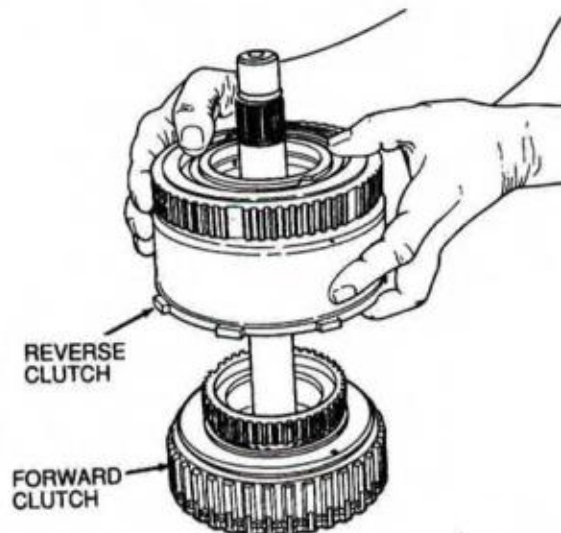

REVERSE CLUTCH

FORWARD CLUTCH

D11484-B

**DISASSEMBLY AND ASSEMBLY OF SUBASSEMBLIES (Continued)**

**Torque Converter Checks**

**Torque Converter Leakage Check**

If welds on the torque converter (7902) indicate leakage, remove the torque converter and make the following check:

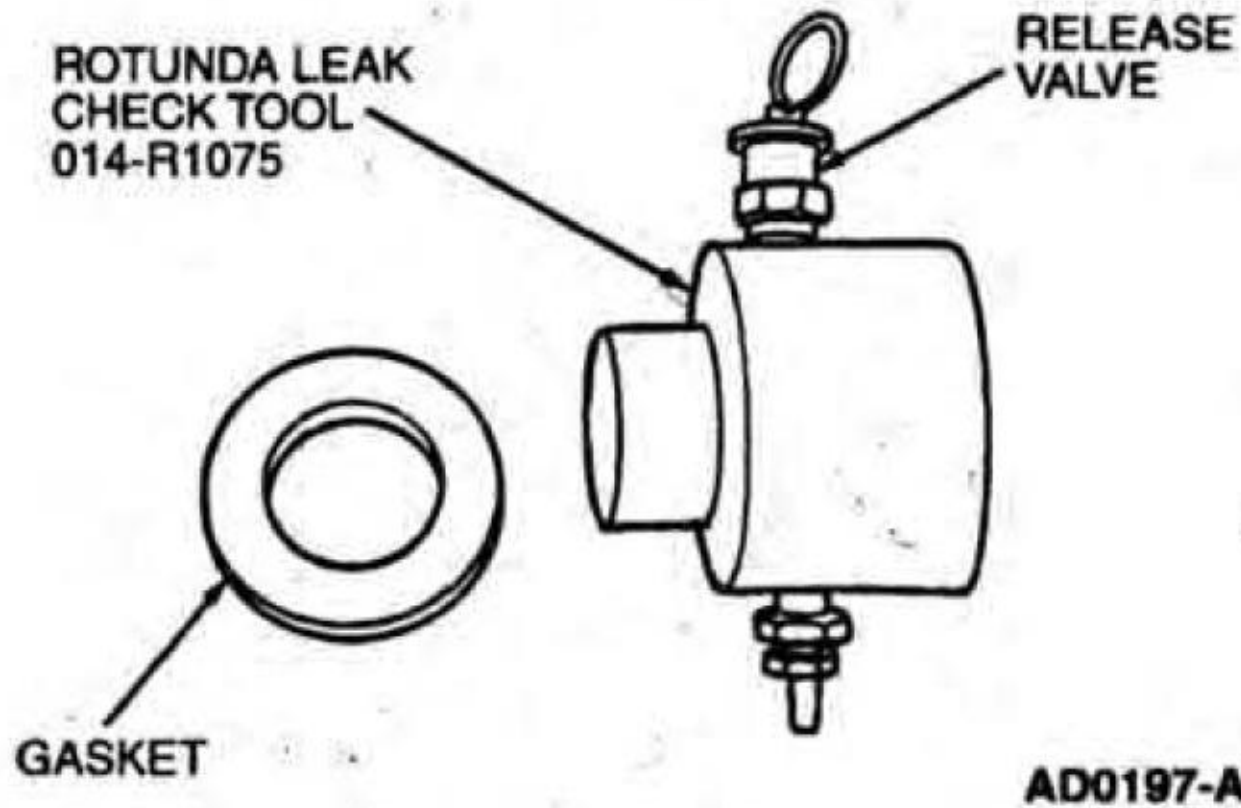

1. Clean the outer surface of the torque converter.
2. Install the Rotunda Leak Check Tool and Gasket 014-R1075 or equivalent into the torque converter hub.

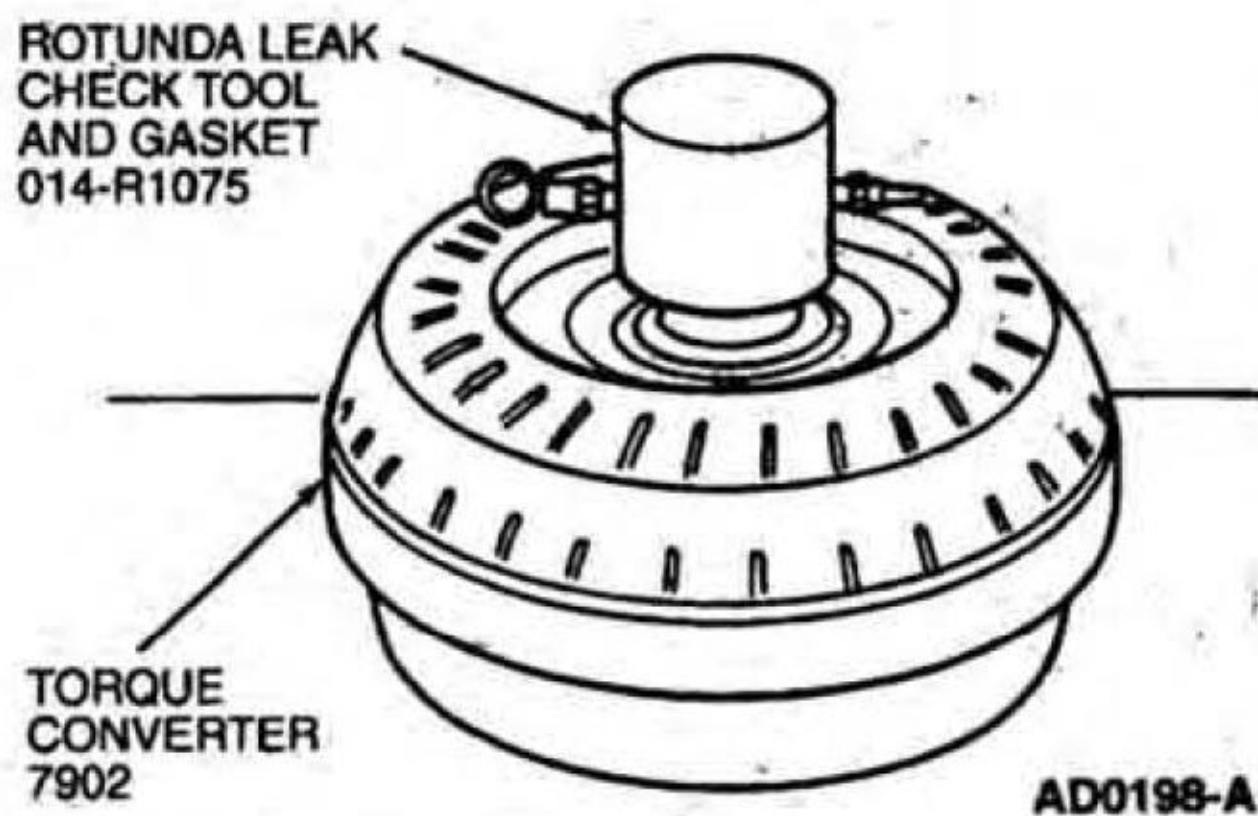

3. Install the torque converter into a press with flywheel studs facing up.

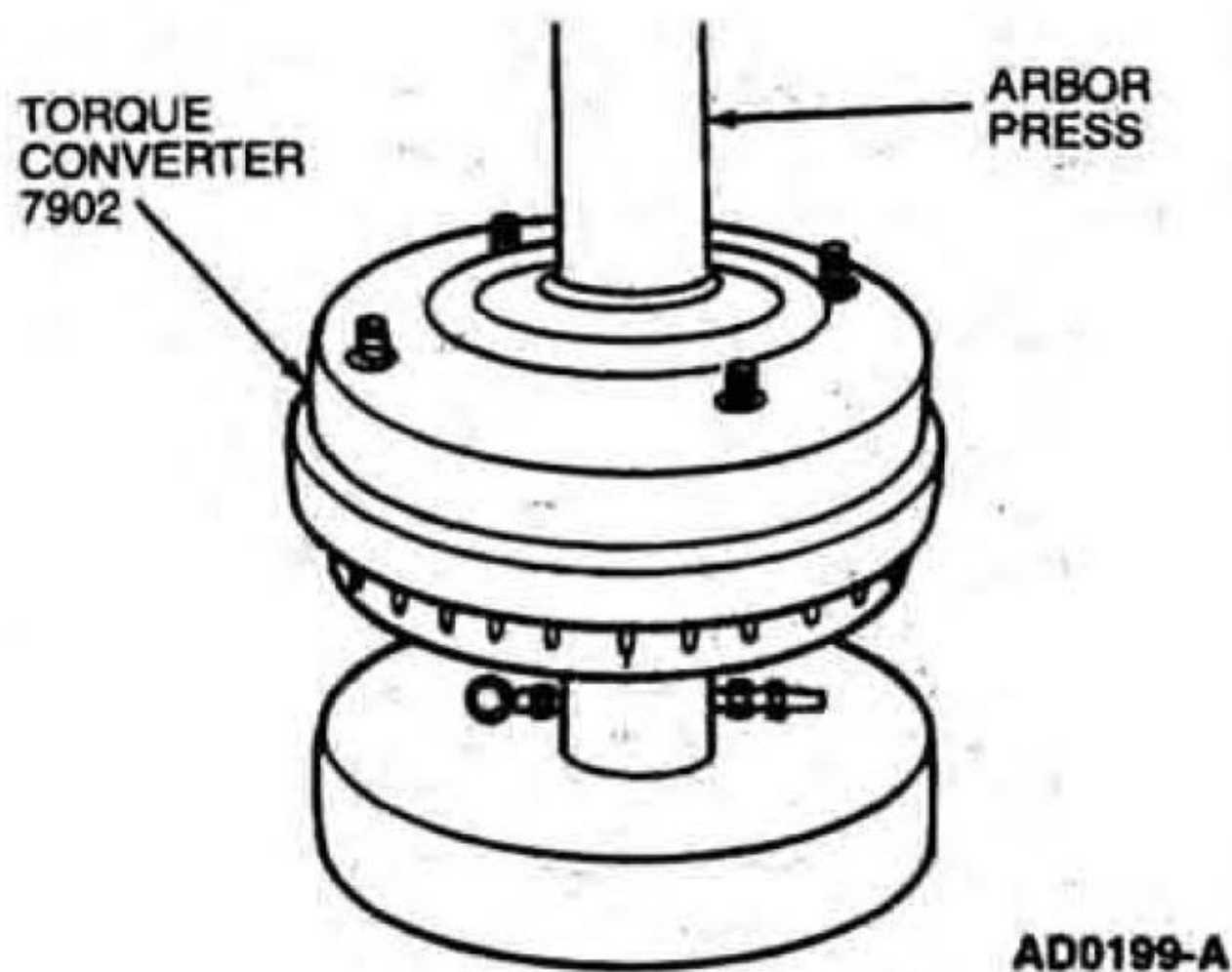

4. Apply enough pressure from the press to seal the tool into the hub of the converter.
5. Connect air hose to the tool, apply maximum 80 psi.

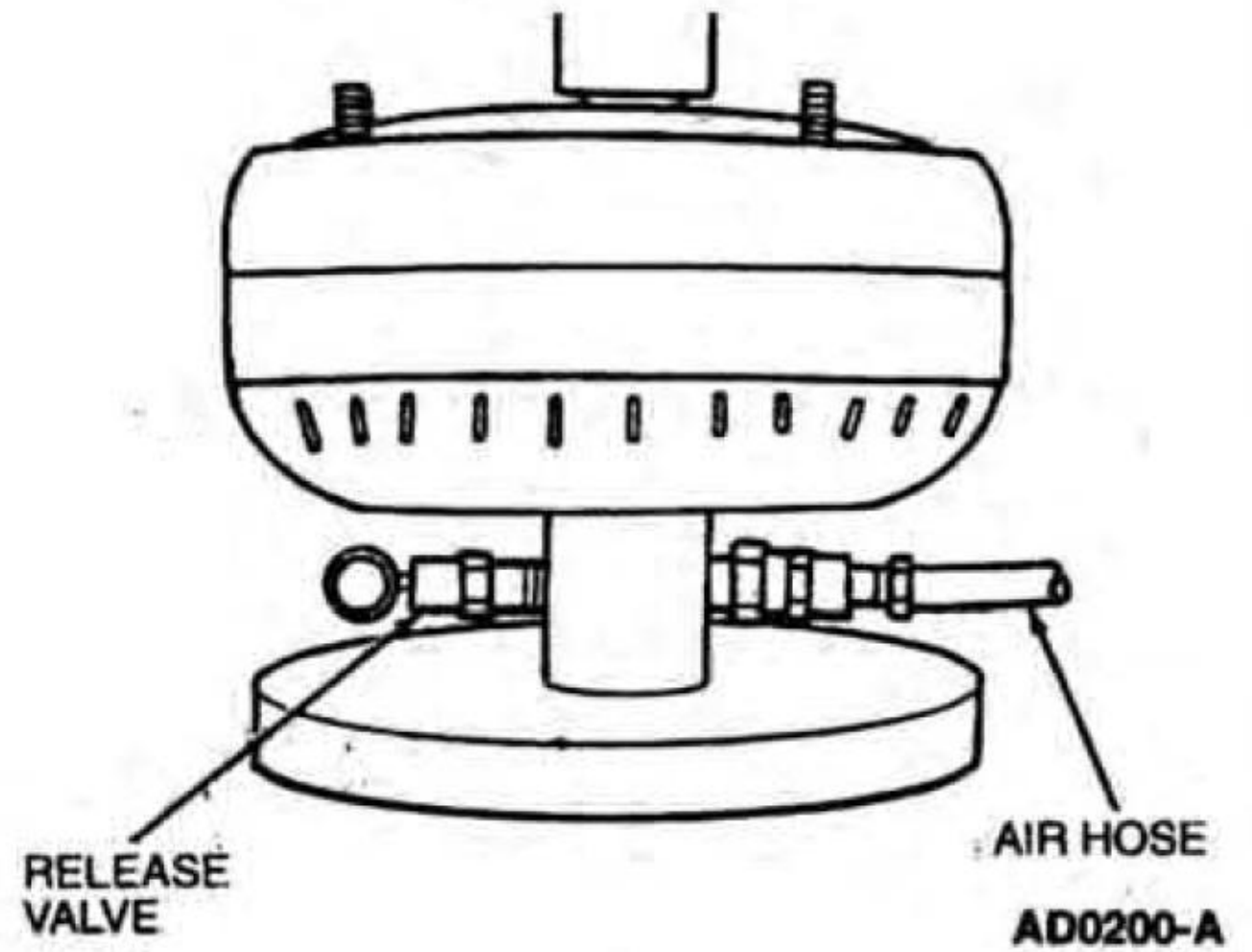

6. With air pressure applied to the torque converter, inspect for leaks at the seams, studs and pilot hub. A soapy water solution may be used in these areas to aid in diagnosis. If leaks are present in these areas replacement of the torque converter is necessary.

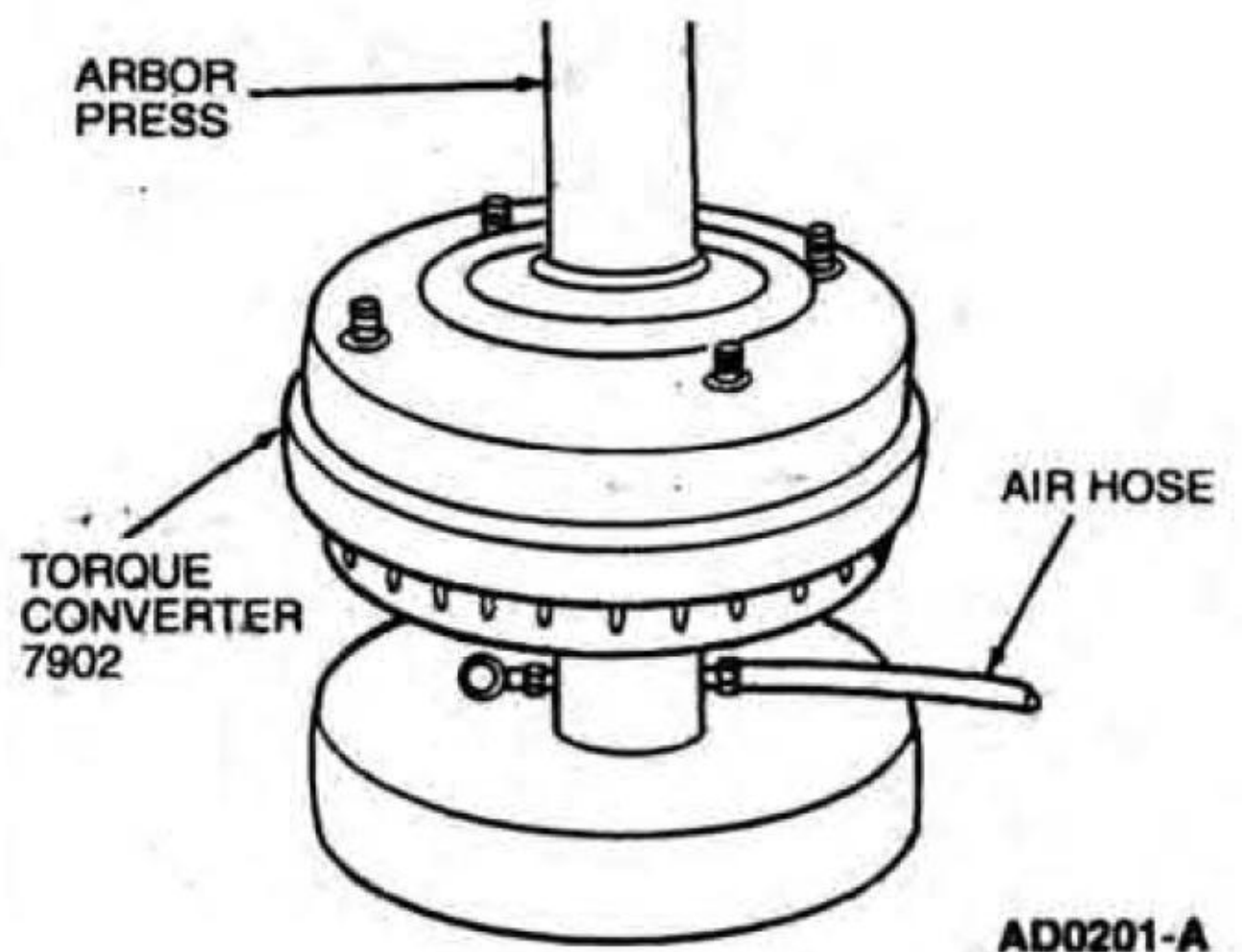

## DISASSEMBLY AND ASSEMBLY OF SUBASSEMBLIES (Continued)

7. Remove air hose, and release air pressure from tool by pulling on release valve ring.

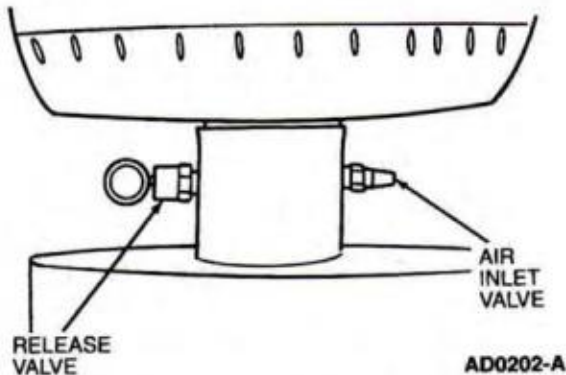

8. Release pressure from the press, and rotate the torque converter so the tool is facing up. Apply pressure from the press to seal the tool into the torque converter.

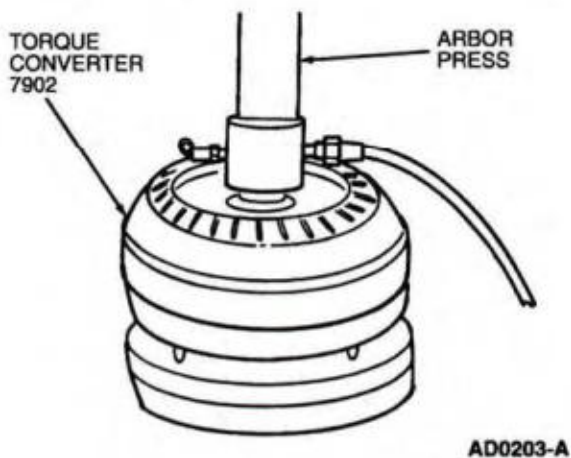

9. Connect air hose to the tool, apply maximum 80 psi.

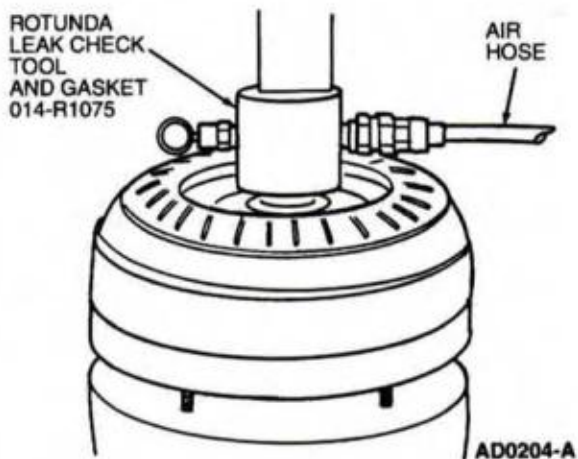

10. With air pressure applied to the torque converter, inspect for leaks at the seams and impeller hub. A soapy water solution may be used in these areas to aid in diagnosis. If leaks are present in these areas replacement of the torque converter is necessary.
11. Remove air hose, and release air pressure from tool by pulling on release valve ring.

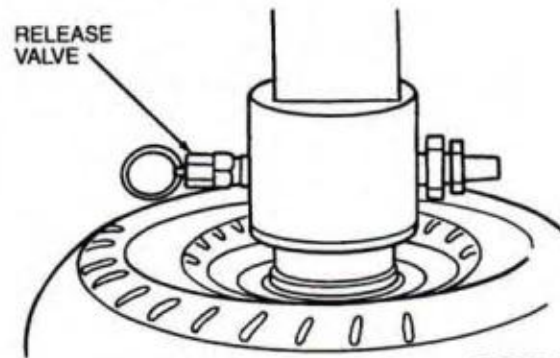

### One-Way Clutch Check

#### SPECIAL SERVICE TOOL(S) REQUIRED

Description	Tool Number
Converter Clutch Holding Tool	T77L-7902-R
Converter Clutch Torquing Tool	T76L-7902-C

1. Insert the Converter Clutch Holding Tool T77L-7902-R in one of the grooves in the stator thrust washer.

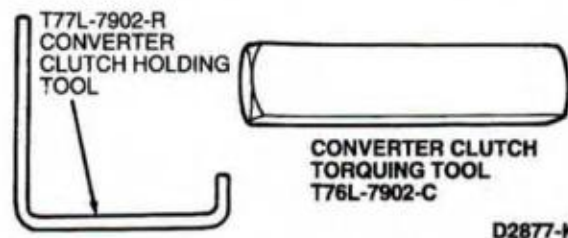

2. Insert the Converter Clutch Torquing Tool T76L-7902-C in converter pump drive hub to engage one-way clutch inner race.
3. Attach a torque wrench to the converter clutch torquing tool. With the converter clutch holding tool held stationary, turn the torque wrench counterclockwise. The torque converter one-way clutch should lock up and hold a 13 N-m (10 lb-ft) force. The torque converter one-way clutch should rotate freely in a clockwise direction until torquing tool contacts the holding tool. Try the clutch for lock up and hold in at least five different locations around the torque converter.
4. If the clutch fails to lock up and hold a 13 N-m (10 lb-ft) torque, replace the torque converter.

## DISASSEMBLY AND ASSEMBLY OF SUBASSEMBLIES (Continued)

### Torque Converter Clutch Checks

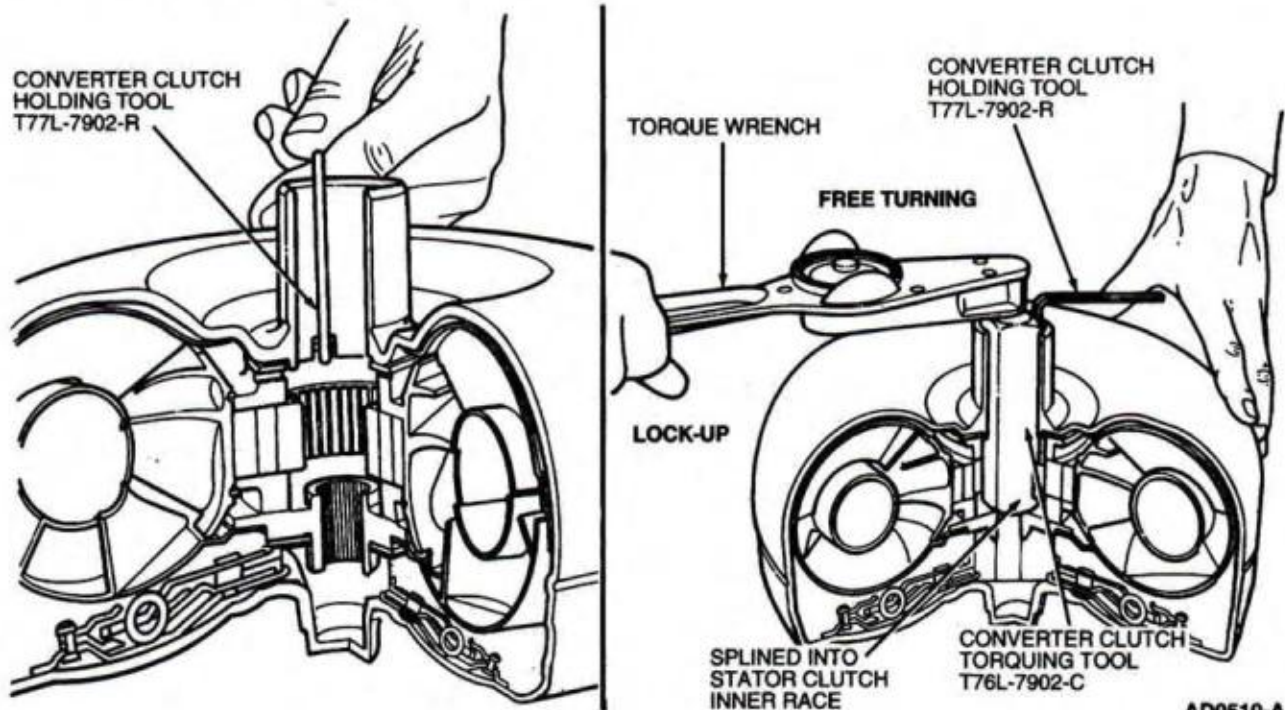

### Stator to Impeller Interference Check

- NOTE: Front pump support (7A108) may remain in front pump support and gear (7A103) during this test.

Position the front pump support on a bench with the spline end of the shaft pointing up.

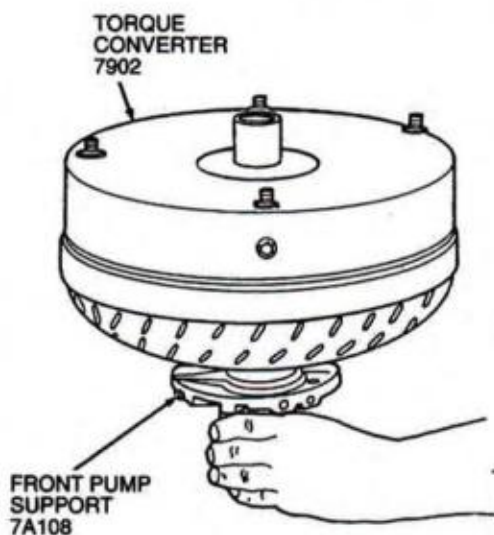

D10443-C

- Mount torque converter on the front pump support with the splines on the one-way clutch inner race, engaging the mating splines of the front pump support.
- Hold the front pump support stationary, and try to rotate the torque converter counterclockwise. The torque converter should rotate freely without any signs of interference or scraping within the torque converter.
- If there is an indication of scraping, the trailing edges of the stator blades may be interfering with the leading edges of the impeller blades. In such cases, replace the torque converter.

### Stator to Turbine Interference Check

- NOTE: Front pump support may remain in front pump support and gear during this test. Position the torque converter on the bench, front side down.
- Install front pump support to engage the mating splines of the front pump support shaft.

## DISASSEMBLY AND ASSEMBLY OF SUBASSEMBLIES (Continued)

3. Install the forward clutch cylinder and shaft (7F207), engaging the splines with the rear clutch hub (7B067).

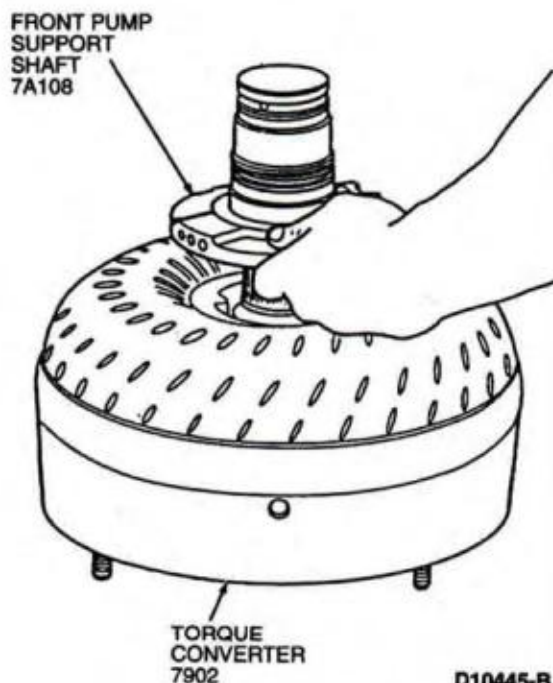

4. Hold the stator shaft stationary and attempt to rotate the rear clutch hub with the forward clutch cylinder and shaft. The turbine and torque converter clutch assemblies should rotate in both directions not exceeding maximum torque of 9.5 N-m (84 lb-in) without any signs of metallic interference or scraping noise.

5. If interference exists, the stator front thrust washer may be worn, allowing the stator to hit the turbine. In such cases, the torque converter must be replaced.

The converter crankshaft pilot should be checked for nicks or damaged surfaces that could cause interference when installing the torque converter into the crankshaft (6303). Check the converter front impeller hub for nicks or sharp edges that would damage the pump seal.

### End Play Check

#### SPECIAL SERVICE TOOL(S) REQUIRED

Description	Tool Number
End Play Checking Tool	T80L-7902-A

1. Insert End Play Checking Tool T80L-7902-A into the torque converter pump drive hub until it bottoms.

2. Expand the sleeve in the turbine spline by tightening the threaded inner post until the tool is securely locked in to the spline.

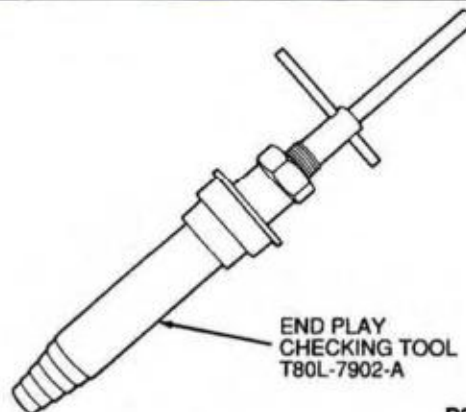
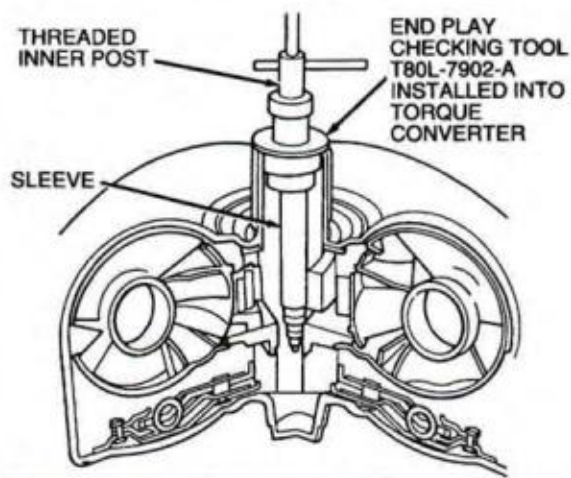

3. Attach Dial Indicator with Bracketry TOOL-4201-C or equivalent to the tool. Position the indicator button on the converter pump drive hub, and set the dial face at 0 (zero).
4. Lift the tool upward as far as it will go and note the indicator reading. The indicator reading is the total end play which the turbine and stator share. Replace the torque converter if the total end play exceeds the limits indicated in the chart below.
5. Loosen the threaded inner post to free the tool and remove the tool from the torque converter. Refer to the following chart for torque converter end-play specifications.

#### TORQUE CONVERTER END PLAY LIMITS

New or Rebuilt Torque Converter	Used Torque Converter
0.36-1.04 mm (0.014-0.041 inch) max	0.36-1.88 mm (0.014-0.074 inch) max

## ASSEMBLY

## Transmission

## SPECIAL SERVICE TOOL(S) REQUIRED

Description	Tool Number
Impact Slide Hammer	T50T-100-A
Servo Piston Remover / Replacer	T92P-70023-A
Gauge Bar	T80L-77003-A
Shift Lever Seal Replacer	T74P-77498-A
Extension Housing Bushing Replacer	T80L-77034-A
Extension Housing Seal Replacer	T61L-7657-A
Servo Piston Selection Tool	T80L-77030-A
Transmission Range (TR) Sensor (MLPS) Alignment Tool	T93P-70010-A
Case Rear Bushing Replacer	T80L-77110-A

## Assembly

1. If bushing was removed, position replacement bushing on Case Rear Bushing Replacer T80L-77110-A and install in bushing bore through the front of the case (7005).
2. Thread Impact Slide Hammer T50T-100-A into Seal Replacer through the back of the case. Install the bushing.

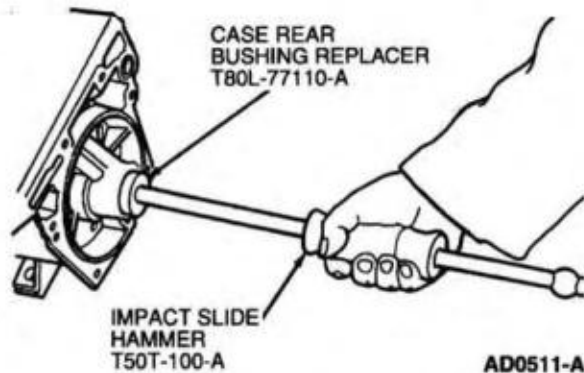

3. With transmission in the vertical position, coat case rear bearing (7F242) with petroleum jelly and install the No. 9 case rear bearing on the transmission case boss.

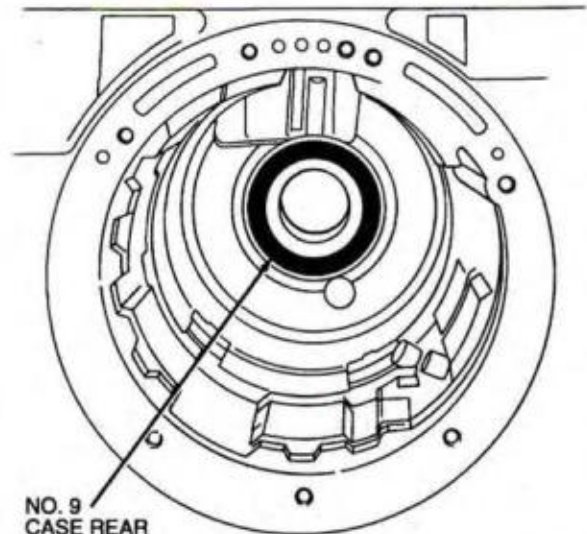

4. Install output shaft (7060), ring gear (7A153) and direct clutch as an assembly.

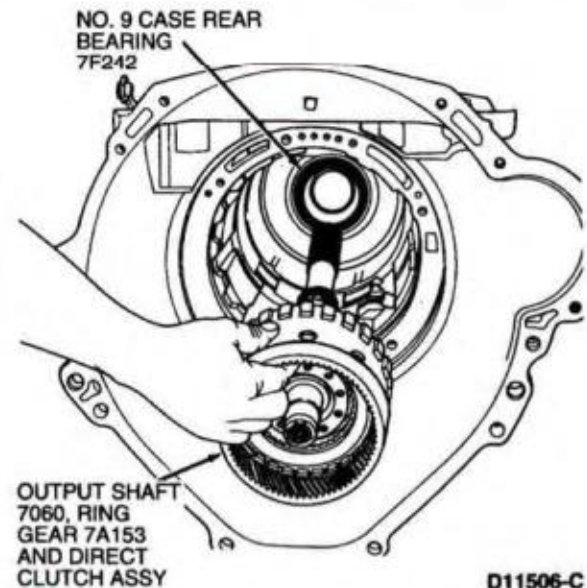

## ASSEMBLY (Continued)

5. Install retaining ring that supports reverse band.

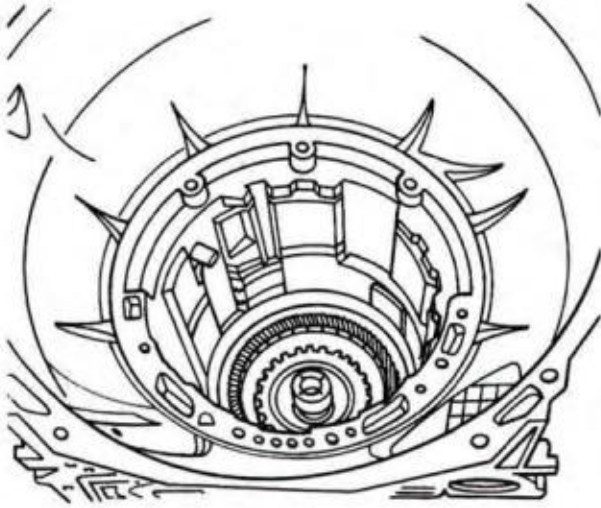

D10562-A

6. Install the reverse band. Make sure reverse band is seated on anchor pins.

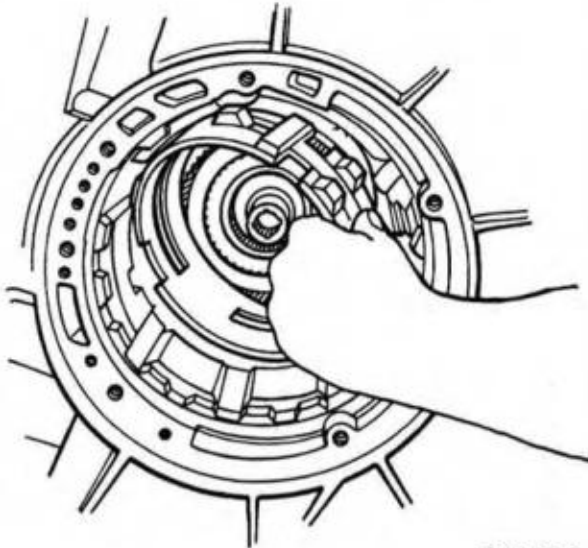

D10162-A

7. NOTE: Forward planetary assembly and planetary gear support assembly cannot be installed unless the notch cut in the planetary gear support assembly is aligned with the overdrive band anchor pin (7F295). Top of planetary gear support assembly should be below snap ring groove.

Install forward planetary assembly and planetary gear support assembly as a unit.

Align notch in planetary gear support assembly with overdrive band anchor pin.

Rotate the output shaft, if necessary, to align the planet carrier splines with the direct clutch hub splines.

8. NOTE: Forward planetary assembly and planetary gear support assembly cannot be installed unless notch cut in planetary gear support assembly is aligned with overdrive band anchor pin.

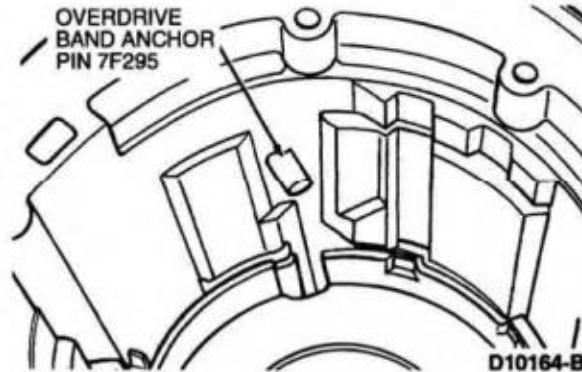

D10164-B

Install the case to planet support spring (7F277) using a screwdriver to position.

ASSEMBLY (Continued)

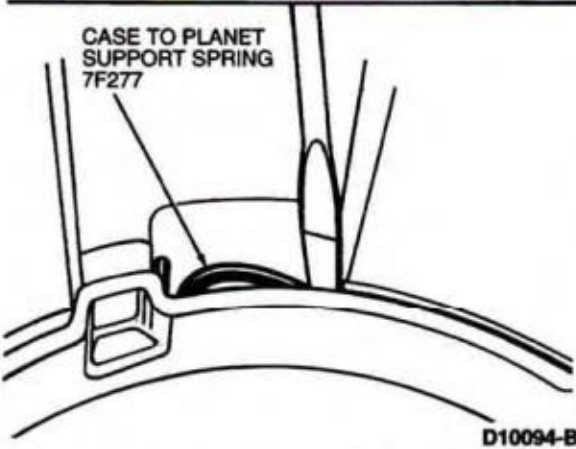
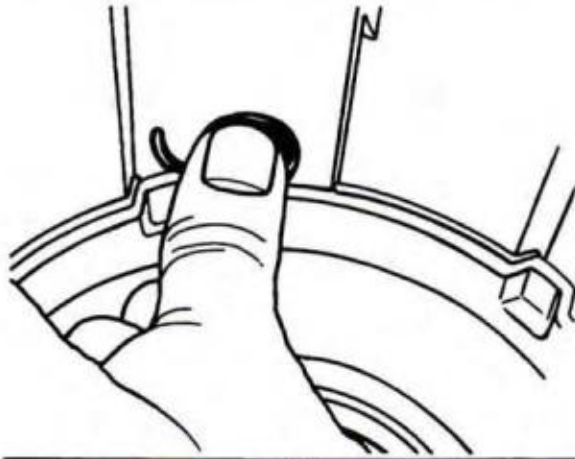

9. Install center planet support retaining ring. Reference retainer ring end tab to overdrive band anchor pin.

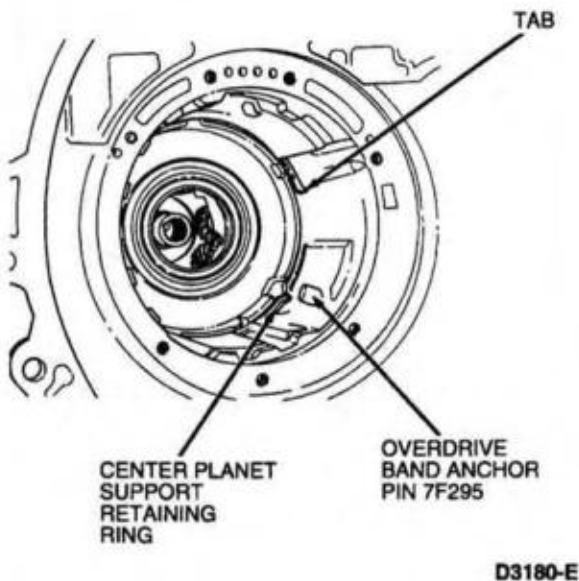

10. Install forward clutch sun gear, No. 5 thrust bearing (7C096), reverse sun gear and shell and No. 4 needle bearing.

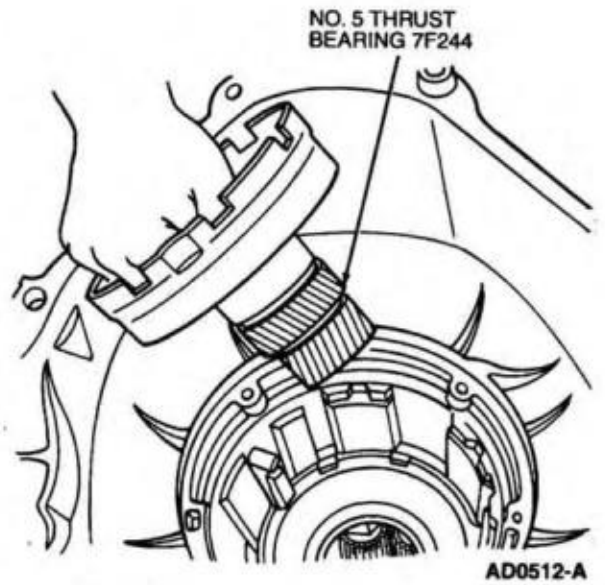

11. Install intermediate stub shaft.

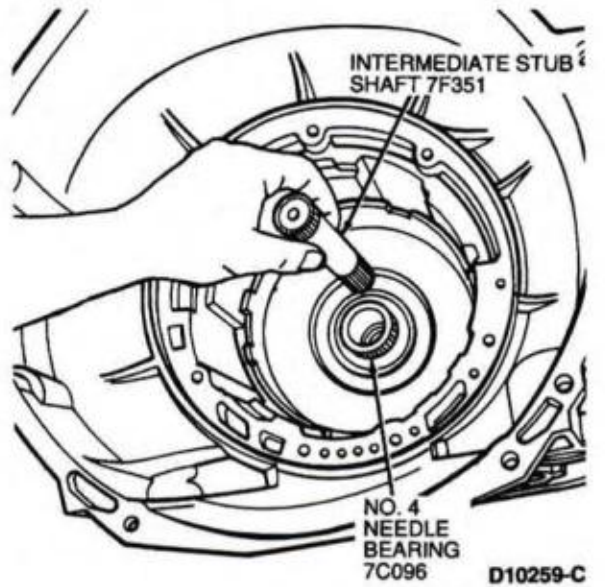

## ASSEMBLY (Continued)

12. Install forward clutch hub and No. 3 forward clutch hub front bearing (7F231).

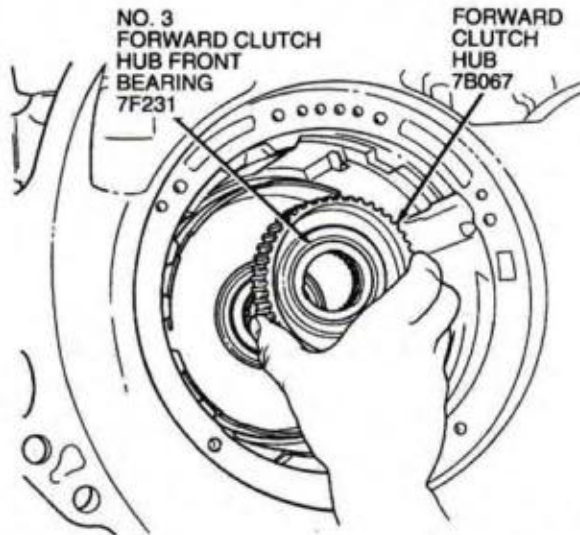

D3178-C

13. Install forward clutch assembly.

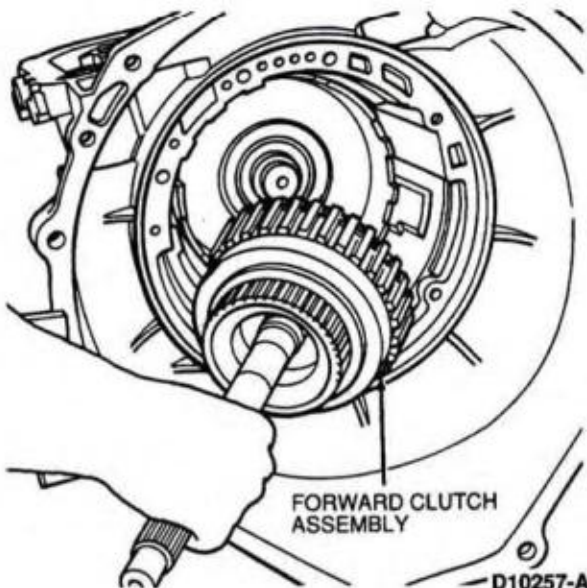

D10257-A

14. NOTE: Wiggle the input shaft while engaging the reverse clutch splines. Make sure the reverse clutch cylinder lugs are completely seated in the notches of the reverse clutch gear and shell (7A019).

Install reverse clutch cylinder assembly.

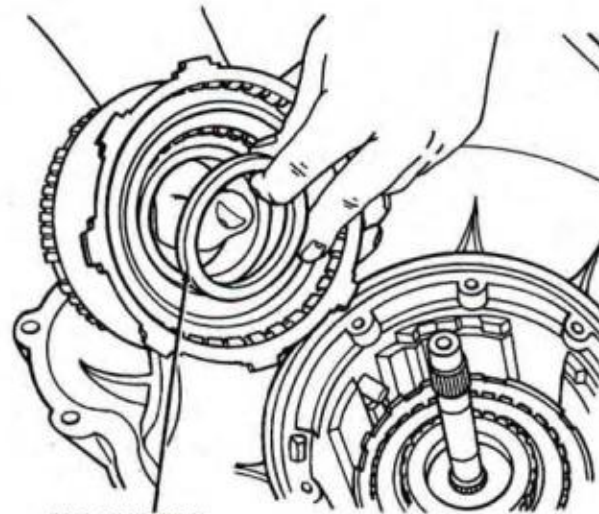

NO. 2 NEEDLE BEARING — 7A166

D10564-A

15. Install overdrive band (7F196) over reverse clutch assembly and position the pocket of the overdrive band against overdrive band anchor pin. Install overdrive servo piston return spring (7F201) and overdrive servo piston assembly. Verify tip of piston assembly engages the pocket of overdrive band. Using Servo Piston Remover / Replacer T92P-70023-A, install piston assembly into the case and compress overdrive servo piston return spring.



SERVO PISTON REMOVER/REPLACER T92P-70023-A

D10507-B

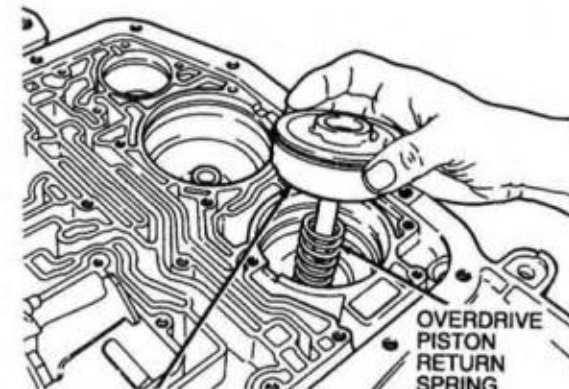

OVERDRIVE SERVO SLEEVE AND PISTON ASSY

OVERDRIVE PISTON RETURN SPRING 7F201

D3164-E

## ASSEMBLY (Continued)

16. Make sure band anchor and tip of the piston assembly are properly positioned against band pockets. Tighten tool until piston is below retaining ring groove, install retaining ring, then remove tool.

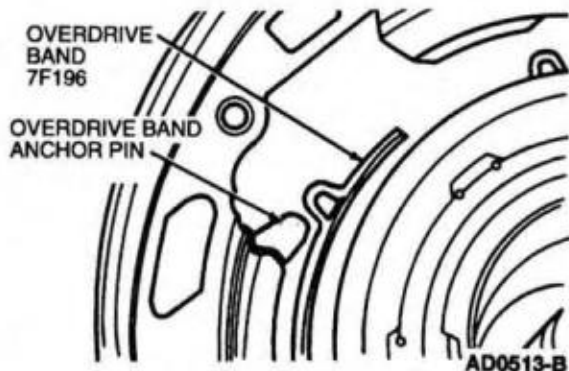

17. Install intermediate clutch as follows:
- Clutch pressure plate (7B066) is the thickest. Install this first with chamfer side down.
  - Clutch plates.
  - Perform Steps 18 and 19 to select the proper intermediate clutch selective steel plate.

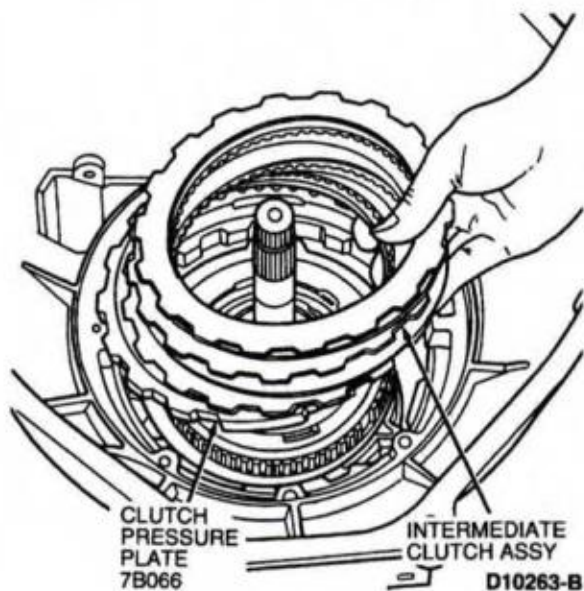

18. With proper intermediate plates selected and installed, perform end clearance check for No. 1 thrust washer using the same tools.

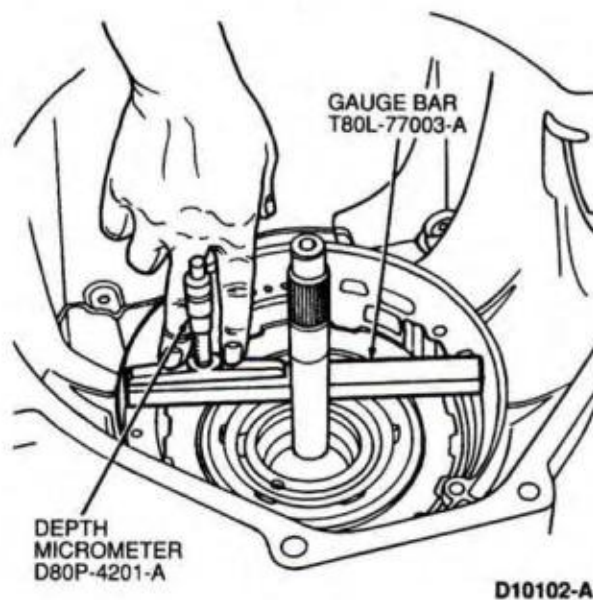

19. NOTE: Maintain downward pressure on clutch pack while measuring depth.
- Measure the intermediate clutch clearance using Depth Micrometer D80P-4201-A or equivalent and Gauge Bar T80L-77003-A.
- Set the gauge bar across the pump case mounting surfaces. The depth at the intermediate clutch separator plate is:
- 42.6-41.7 mm (1.677-1.643 inch)
- Check the clearance again 180 degrees opposite to ensure the average depth is within tolerance.
- If the depth is not within tolerance, the following size selective steel plates are available:

Selective Steel Plates
1.80-1.7 mm (0.071-0.067 inch)
2.05-1.95 mm (0.081-0.077 inch)
2.31-2.20 mm (0.091-0.087 inch)
2.56-2.46 mm (0.101-0.097 inch)

Install correct plate and check clearance.

## ASSEMBLY (Continued)

## Transmission Selective Thrust Washer Procedure

1. Position the Depth Micrometer D80P-4201-A or equivalent on Gauge Bar T80L-77003-A so that the depth is measured at the reverse clutch drum thrust face. Check the end play 180 degrees opposite to determine the average depth. Refer to the Selective Thrust Washers chart for specifications.

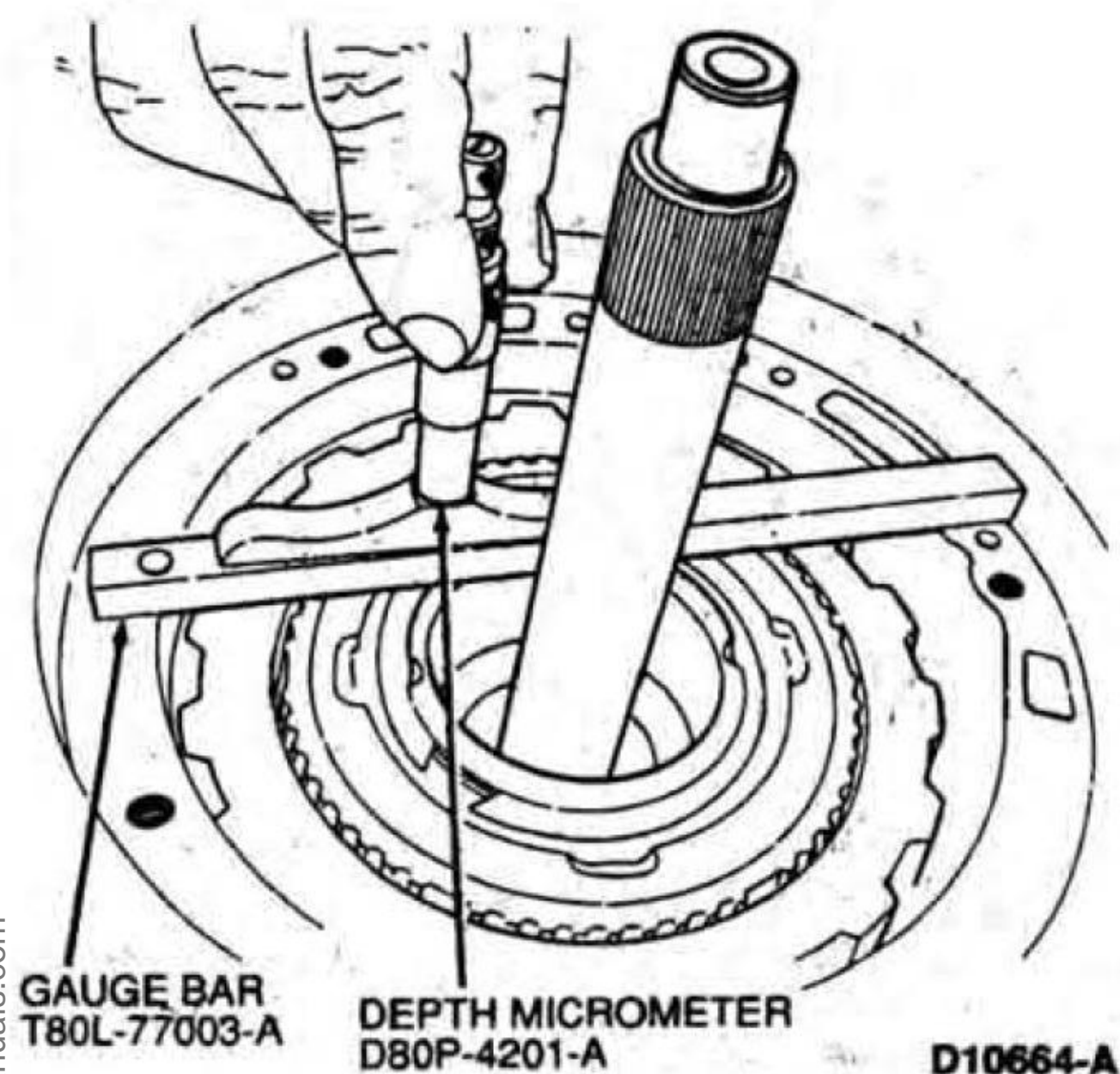

## SELECTIVE THRUST WASHERS\*

Depth	Thickness	Color Code
37.706-38.184 mm (1.485-1.503 inch)	1.270-1.372 mm (0.050-0.054 inch)	Green
38.185-38.641 mm (1.504-1.521 inch)	1.727-1.829 mm (0.068-0.072 inch)	Yellow
38.642-39.073 mm (1.522-1.538 inch)	2.159-2.261 mm (0.085-0.089 inch)	Natural
39.074-39.505 mm (1.539-1.555 inch)	2.591-2.692 mm (0.102-0.106 inch)	Red
39.506-40.165 mm (1.556-1.581 inch)	3.023-3.124 mm (0.119-0.123 inch)	Blue

- a. The thrust washer is located on the stator support which is attached to the back of the pump housing.

2. Install No. 1 thrust washer (7D014) on pump body using petroleum jelly to hold in place.

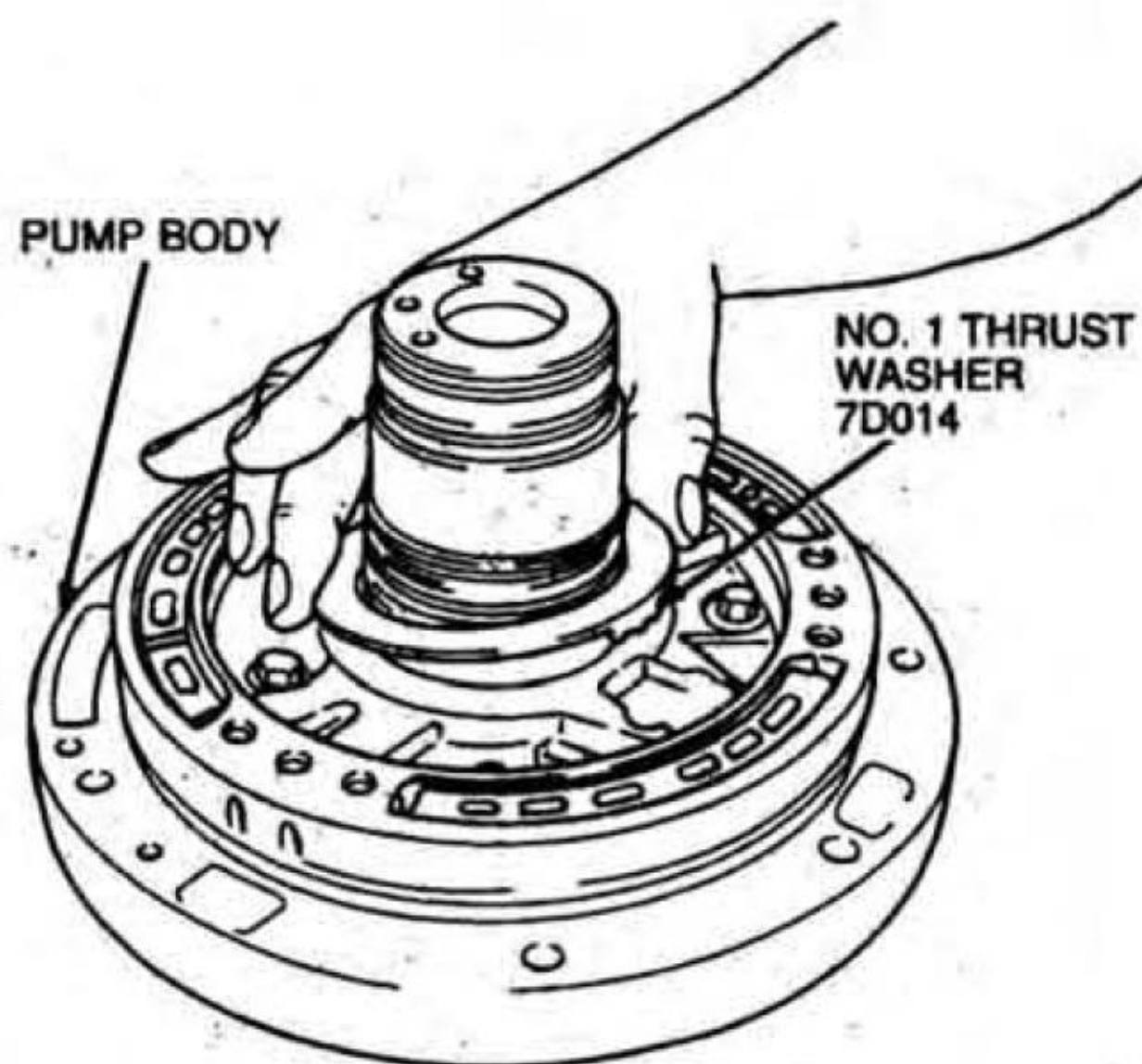

D3833-E

3. Install pump gasket. Make sure pump gasket is positioned and case passages are covered.
4. To maintain pump-to-case alignment, use a fabricated M8-1.25 mm bolt (head removed) as a guide. Install in the 12 o'clock position using petroleum jelly on pump-to-case seal surfaces to aid pump installation.

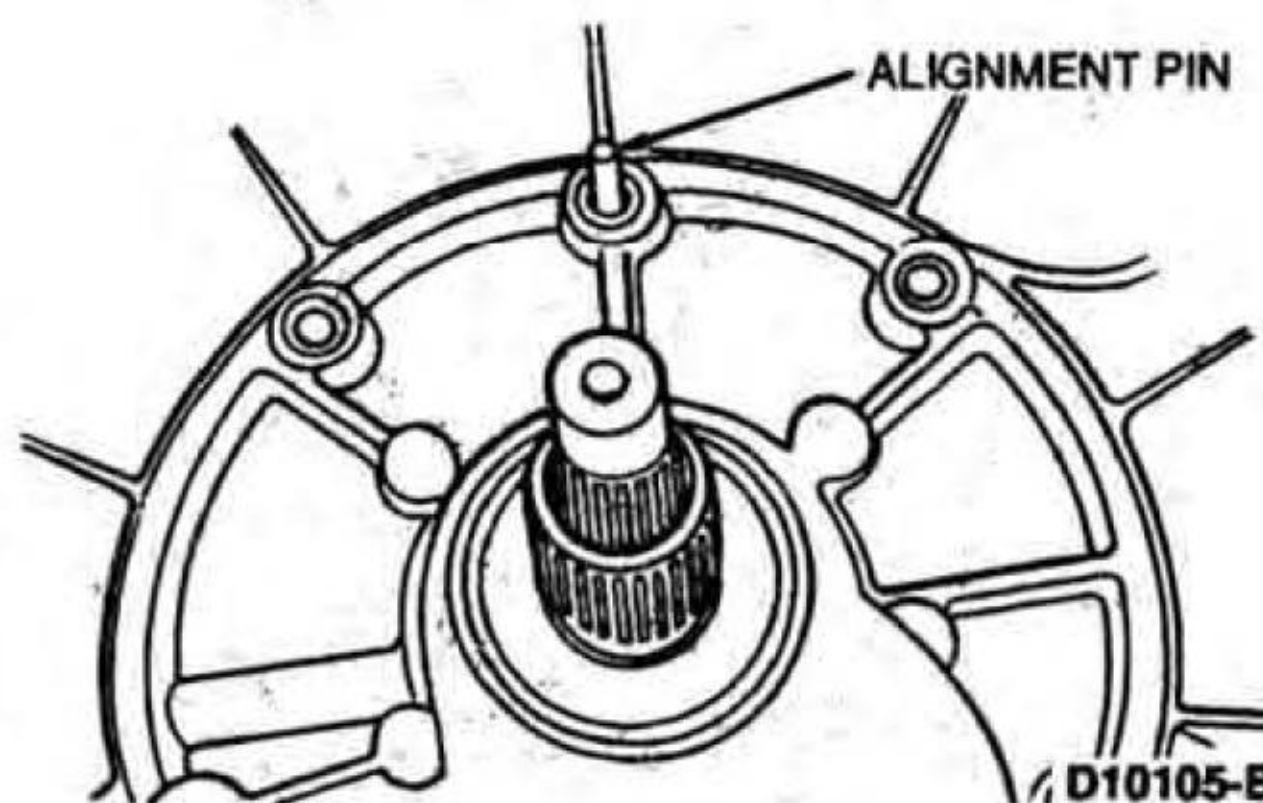

## ASSEMBLY (Continued)

5. To aid assembly, grasp input shaft and wiggle shaft while pressing down on pump.

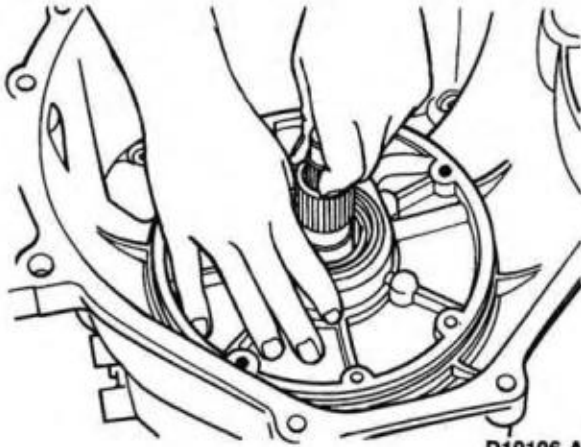

D10106-A

6. Remove alignment bolt and install pump-to-case bolts. Alternate bolt tightening to draw the pump fully into the case. Tighten to 20-26 N·m (15-19 lb-ft).

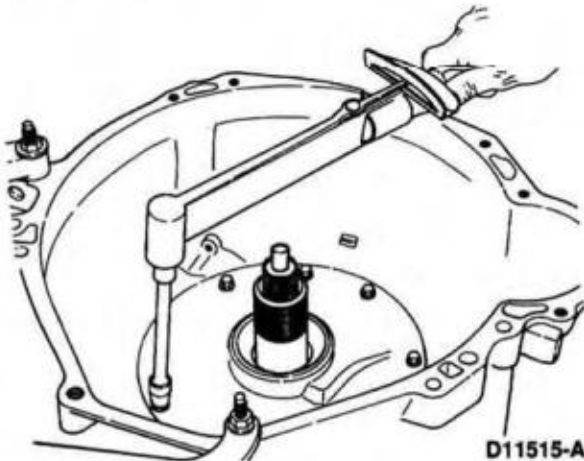

D11515-A

7. Place transmission in the horizontal position. Install parking pawl (7A441) and parking pawl return spring (7D070). Slide parking pawl shaft (7D071) into case through parking pawl.

PARKING PAWL  
7A441

PARKING PAWL  
RETURN SPRING  
7D070

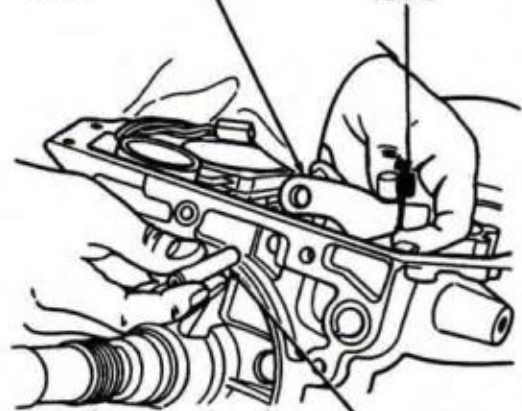

PARKING PAWL  
SHAFT  
7D071

D8902-B

8. Install output shaft speed sensor (OSS). Tighten bolt to 7-10 N·m (62-88 lb-in).

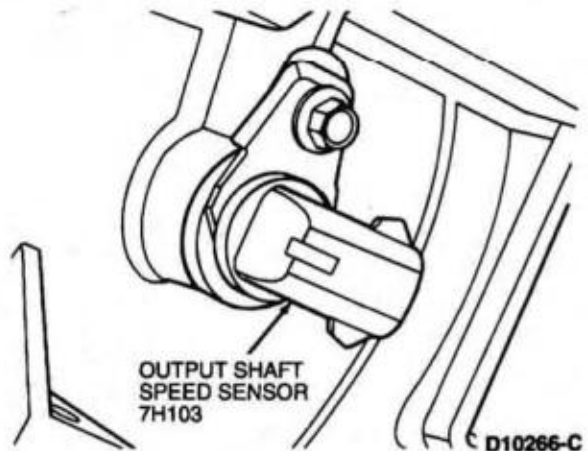

OUTPUT SHAFT  
SPEED SENSOR  
7H103

D10266-C

## ASSEMBLY (Continued)

9. Install manual control lever seal using Shift Lever Seal Replacer T74P-77498-A.

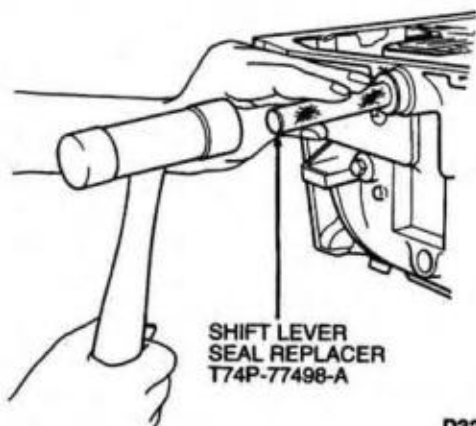

D3258-E

10. Install EPC solenoid.

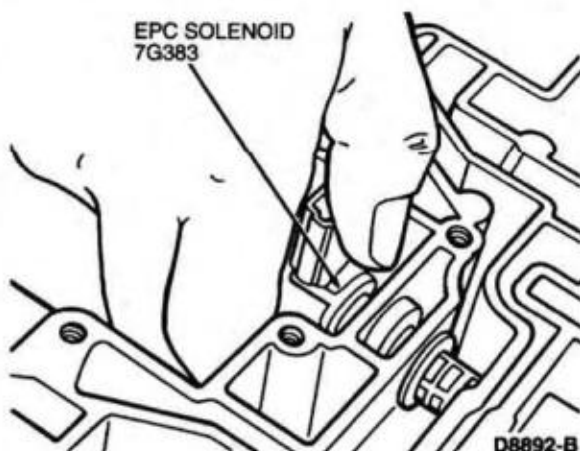

D8892-B

11. If removed, install new extension housing bushing using Extension Housing Bushing Replacer T80L-77034-A.

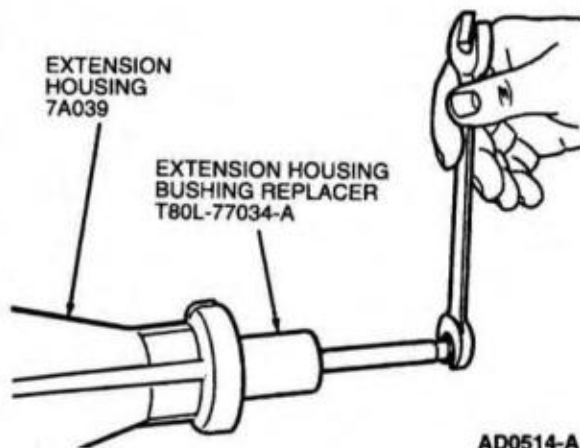

AD0514-A

12. Install new extension housing gasket (7086) and extension housing (7A039). Tighten bolts to 25-30 N·m (19-22 lb-ft).

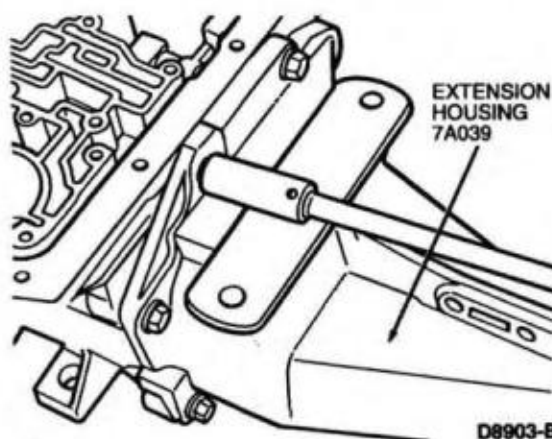

D8903-B

13. Install extension housing seal using Extension Housing Seal Replacer T61L-7657-A.

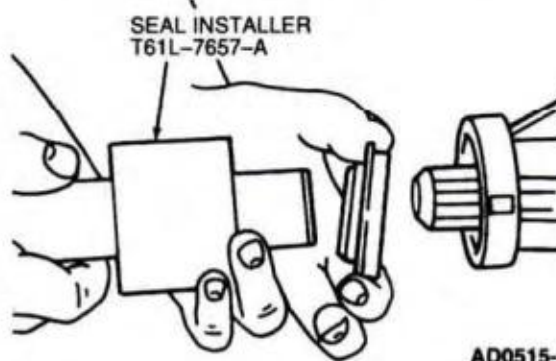

AD0515-A

## ASSEMBLY (Continued)

14. Position manual valve detent lever (7A115) and parking lever actuating rod (7A232) into case. Parking lever actuating rod must be positioned over parking pawl.

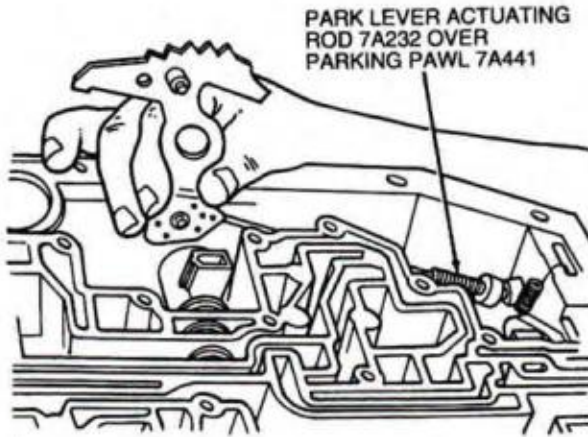

D10568-B

15. Slide manual control lever (7A256) into case and position through detent. Install nut and tighten to 26-37 N·m (20-27 lb-ft).
16. Install manual lever shaft retaining pin (7B210).
17. Install fluid screen into case (head first).

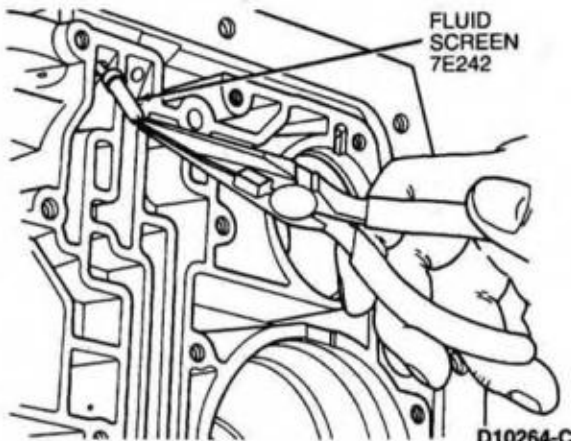

D10264-C

18. Install reverse band servo spring (7D031), reverse band servo piston and rod (7D189). When band and / or piston and rod assembly replacement becomes necessary, determine the correct length of the reverse servo piston, proceed as follows:
- Lubricate the reverse piston seal to facilitate assembly and to prevent damage to the seal.

- Install the reverse servo piston and return spring. Do not install the piston cover or retaining ring.
- Install Servo Piston Selection Tool T80L-77030-A. Tighten the band apply bolt on Servo Piston Selection Tool T80L-77030-A to 5.6 N·m (50 lb-in).

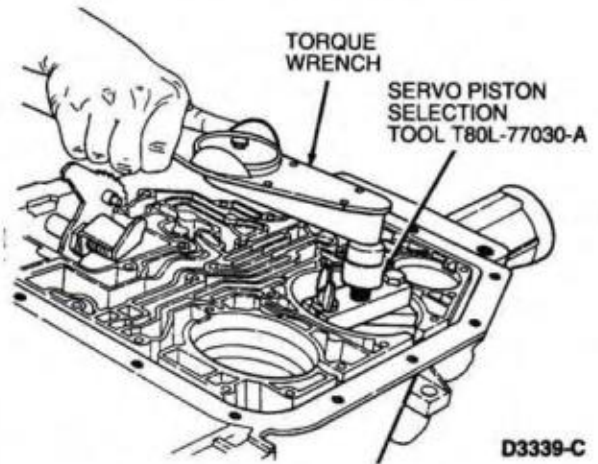

D3339-C

- Attach Dial Indicator with Bracketry TOOL-4201-C or equivalent and position the indicator stem on the flat portion of the piston. Zero the dial indicator.

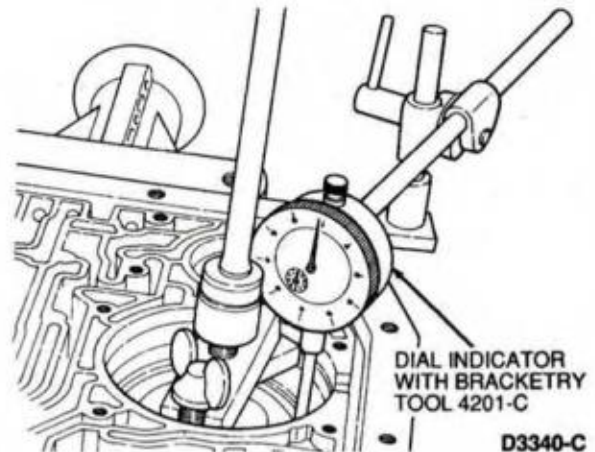

D3340-C

- Thread the bolt out of the selector tool until the piston stops against the bottom of the tool.

## ASSEMBLY (Continued)

f. Read the amount of piston travel on the dial indicator.

- If the travel is 2.845-6.020 mm (0.112-0.237 inch), the piston length is within specification.
- If the travel is not within specification, selective pistons are available in the following lengths:

ID

74.56 mm (2.936 inch) 1 groove

75.92 mm (2.989 inch) 2 grooves

77.29 mm (3.043 inch) 3 grooves

Length of rod measured from piston surface to end of rod.

Select the proper rod to bring the servo piston travel within specification.

- g. Remove the servo selection tool and dial indicator.
- h. Lubricate the cover seal to facilitate assembly and to prevent damage to the seal. Place servo cover and retaining ring in servo bore.

19. Tighten screw on Servo Piston Remover/Replacer T92P-70023-A to allow enough clearance to install retaining ring.

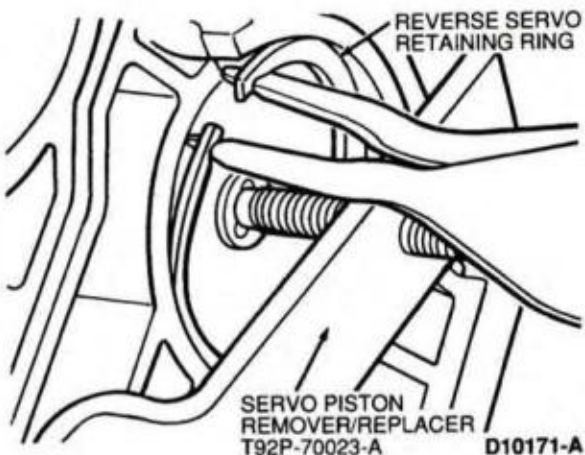

20. NOTE: Retainer is secured by main control. Install the components for 2-3 accumulator in the following order:

- upper accumulator seal (7F250)
- lower accumulator seal (7F249)
- accumulator piston (7F251)
- accumulator piston spring (7F285)
- accumulator spring retainer (7F252)

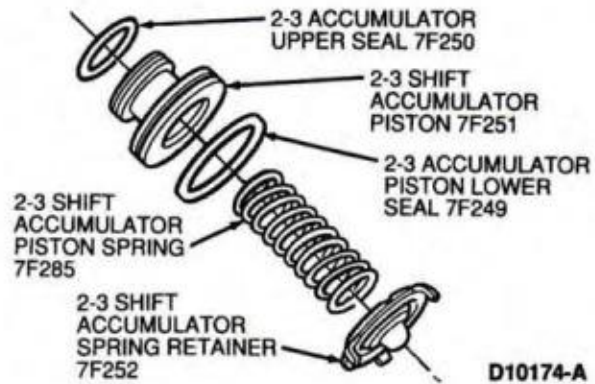

21. Install the components for 1-2 accumulator in the following order:

- 1-2 accumulator spring
- accumulator piston seal (7F248)
- accumulator piston
- lower accumulator seal
- 1-2 accumulator spring
- cover and seal assembly
- accumulator piston retaining ring (7384)

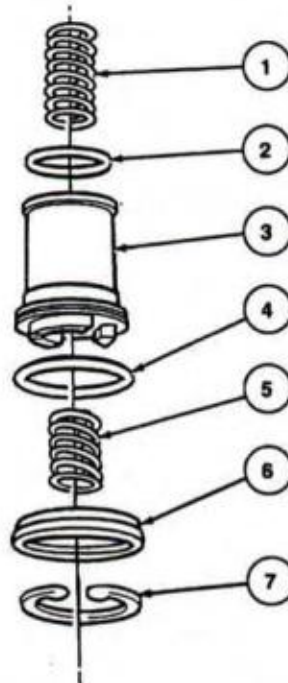

Item	Part Number	Description
1	7F284	1-2 Accumulator Spring
2	7F248	Accumulator Piston Seal
3	7F251	Accumulator Piston

(Continued)

## ASSEMBLY (Continued)

Item	Part Number	Description
4	7F249	Lower Accumulator Seal
5	7F284	1-2 Accumulator Spring
6	7G300	Cover and Seal Assy
7	7384	Accumulator Piston Retaining Ring

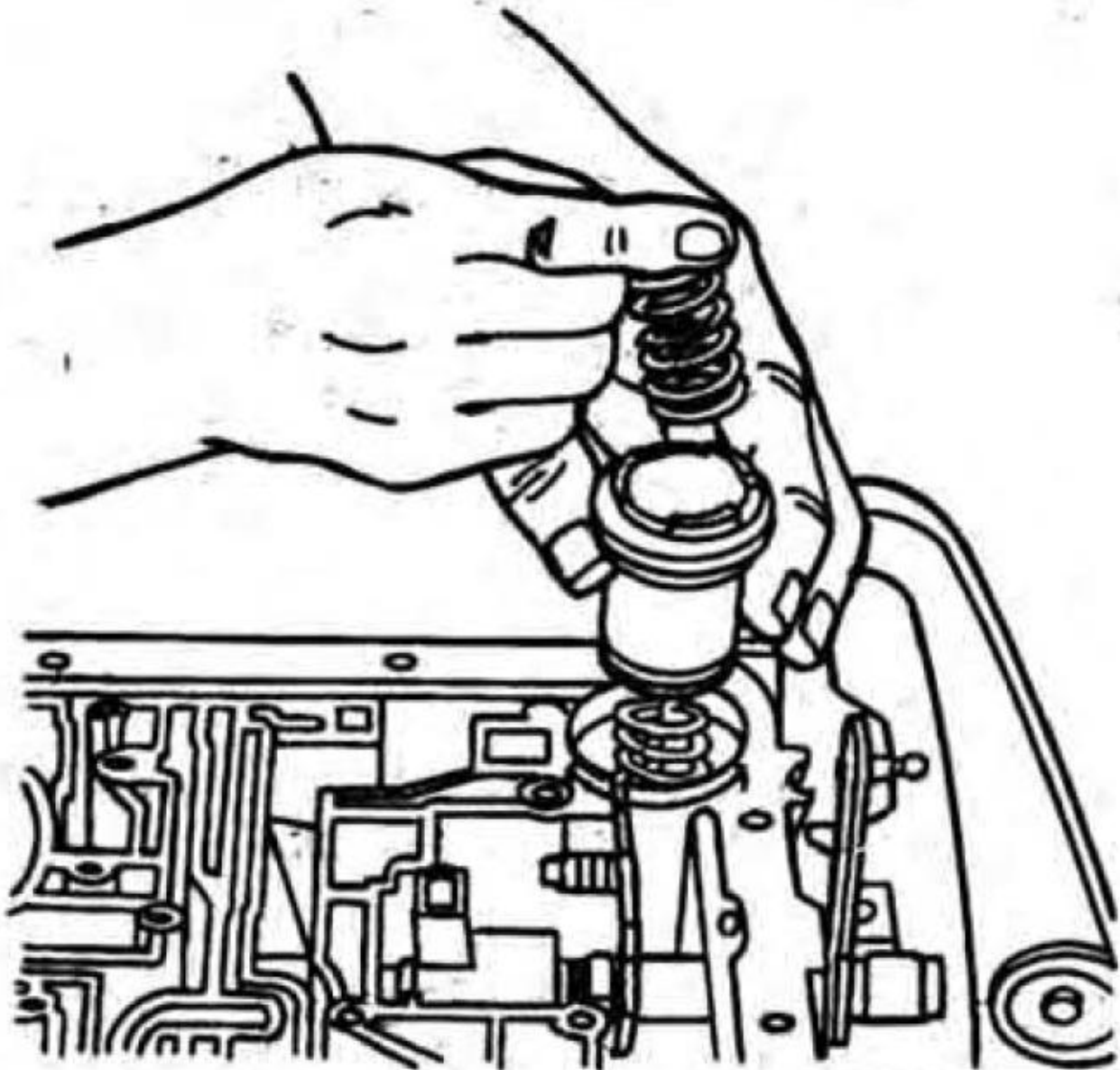

AD0324-A

22. NOTE: Tab on connector is secured by main control.

Align and install wiring connector into case. Inspect O-ring and replace if required.

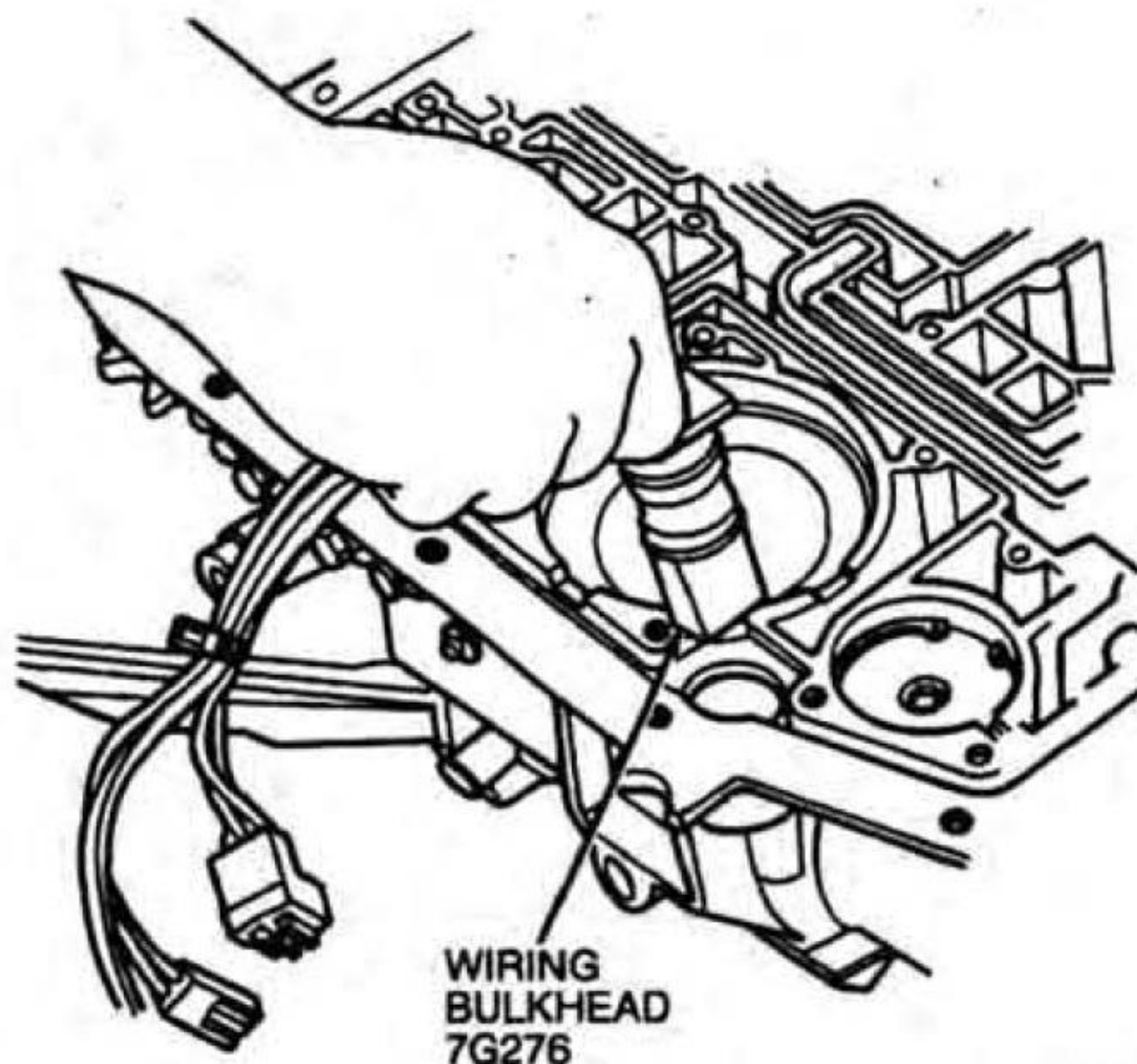
WIRING  
BULKHEAD  
7G276

D10261-B

23. Position main control valve body (7A100) using the two alignment bolts as a guide.
24. Install the EPC solenoid bracket. Loosely install one long bolt.

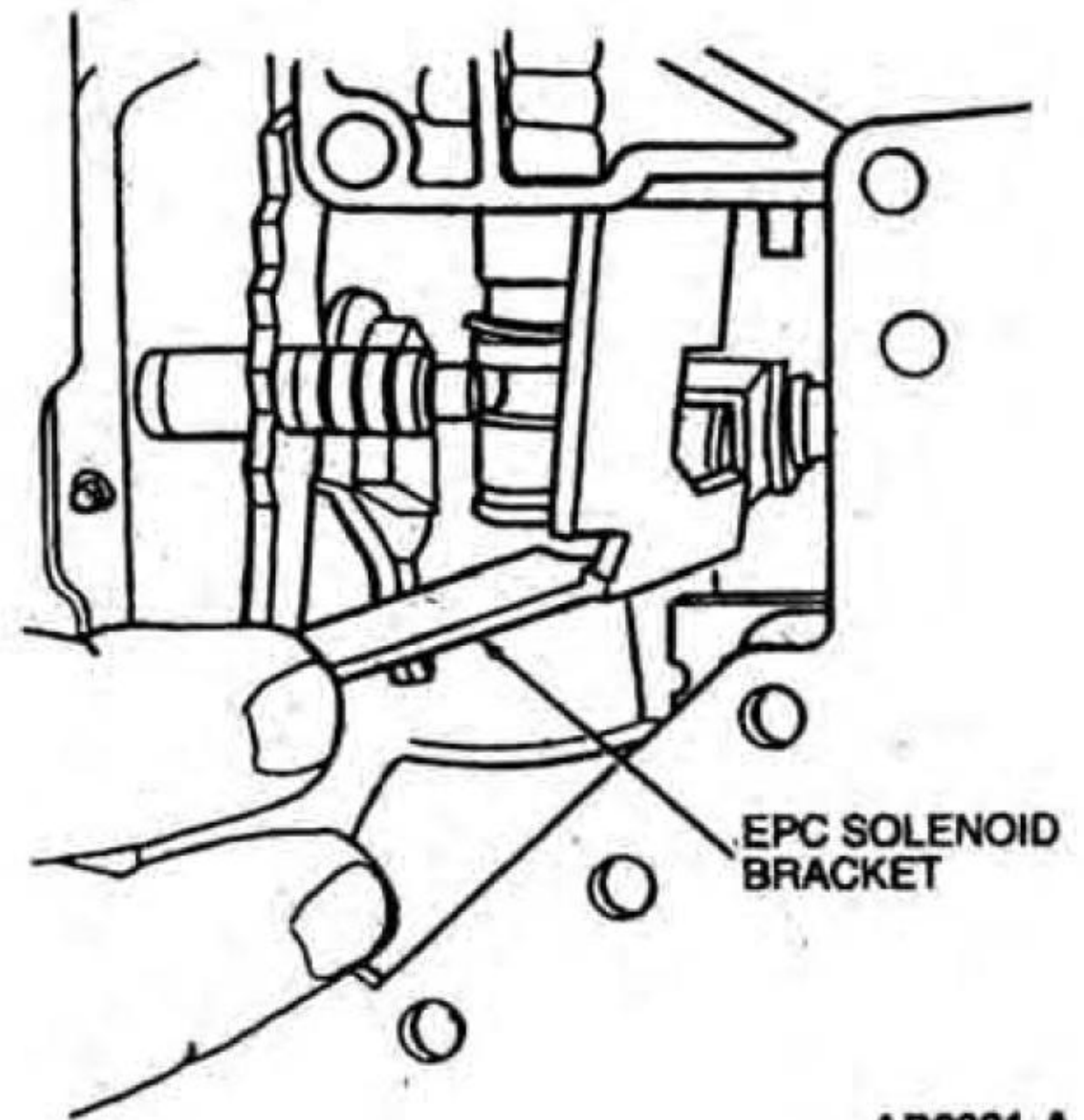
EPC SOLENOID  
BRACKET

AD0321-A

25. Loosely install 11 long and 12 short bolts.
26. Install manual control valve detent lever spring (7A261) and one bolt.

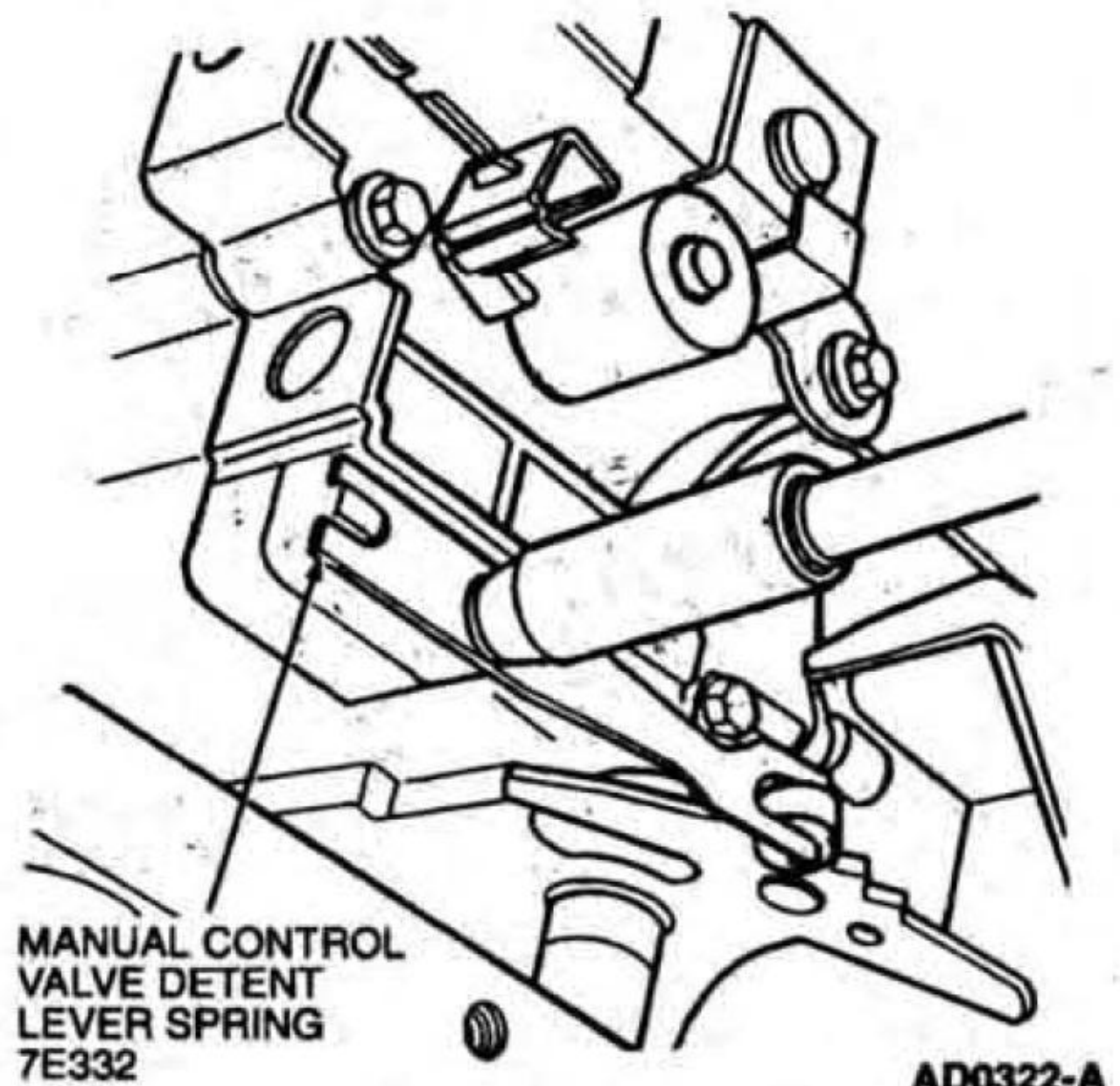
MANUAL CONTROL  
VALVE DETENT  
LEVER SPRING  
7E332

AD0322-A

27. Tighten the 25 main control valve body-to-case bolts to 9-11 N·m (80-97 lb-in).

ASSEMBLY (Continued)

Main Control to Case

INSTALLATION

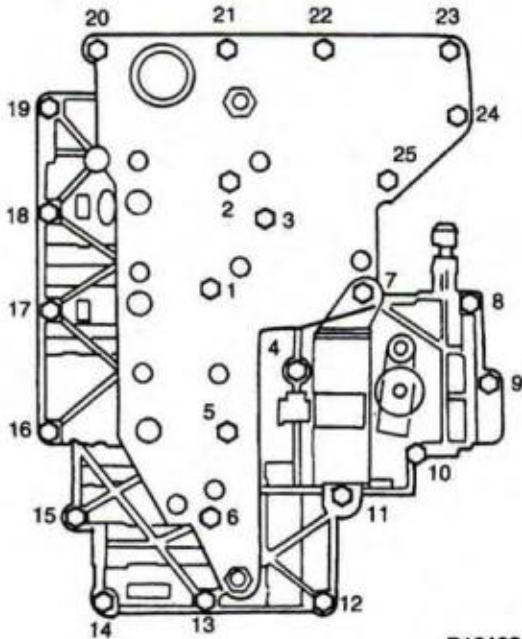

D12122-C

28. Connect wiring connectors to transmission fluid temperature sensor (TFT), shift solenoids (7G484), TCC solenoid and EPC solenoid.

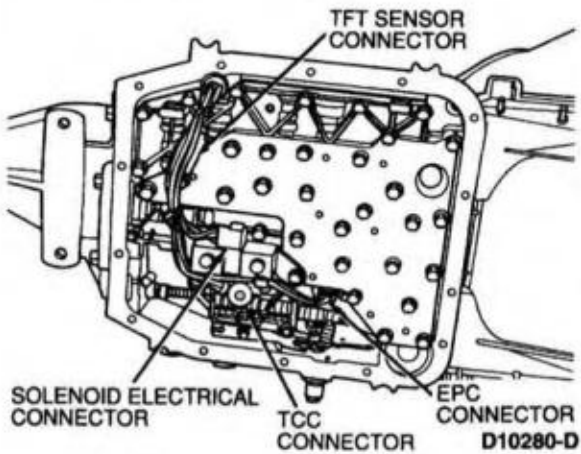

D10280-D

29. Install new filter and grommet.

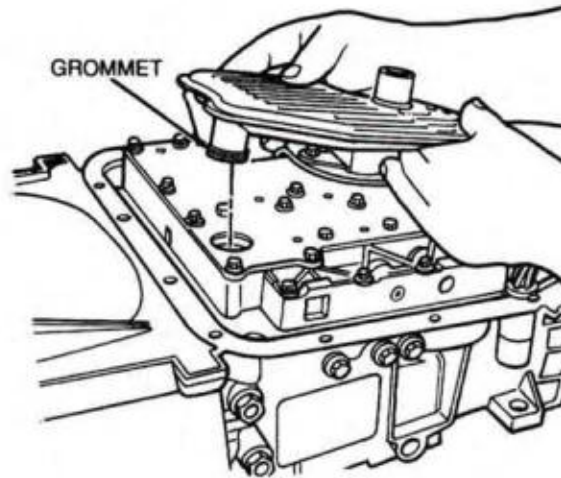

D10570-C

30. Install transmission range (TR) sensor on manual control lever and loosely install bolts.

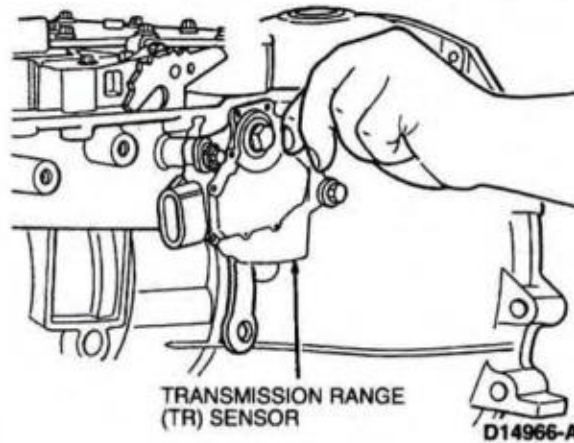

D14966-A

ProCarManuals.com

## ASSEMBLY (Continued)

31. NOTE: PARK is the last detent when the manual control lever is full forward. Return two detents toward output shaft for NEUTRAL.

Position manual control lever in NEUTRAL.

Insert Transmission Range (TR) Sensor (Manual Lever Position Sensor Alignment Tool) T93P-70010-A into slots. Align all three slots on transmission range (TR) sensor with three tabs on tool.

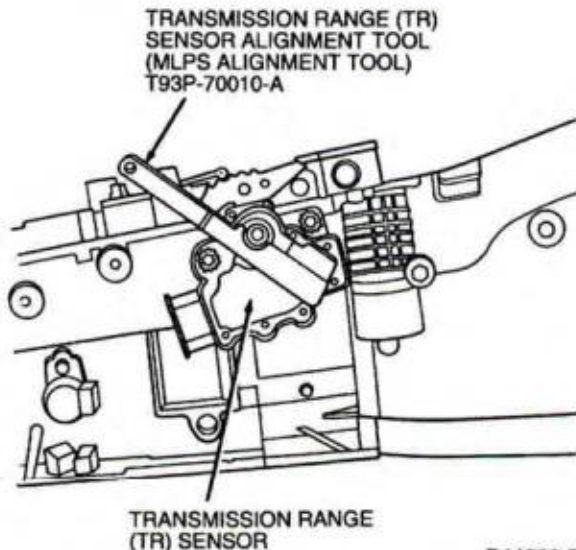

32. Tighten transmission range (TR) sensor bolts to 7-10 N-m (62-88 lb-in).
33. NOTE: Transmission pan-to-case gasket is reuseable if not damaged.
- Clean, inspect and install pan-to-case gasket and transmission pan. Tighten all bolts to 12-15 N-m (9-11 lb-ft).

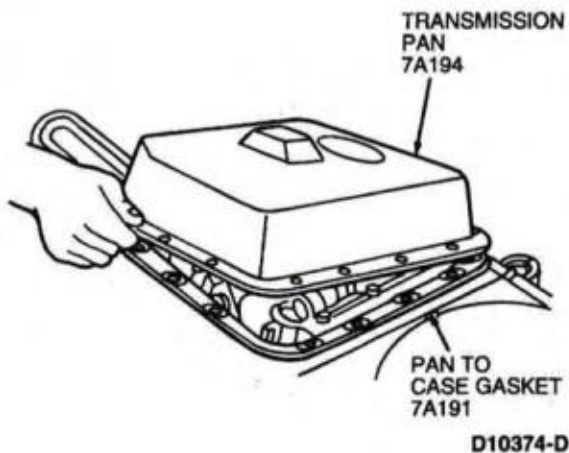

## INSTALLATION

## Transmission

## Installation

NOTE: Prior to installing transmission, apply Multi Purpose Grease DOAZ-19584-AA or equivalent meeting Ford specification ESA-M1C45-A to the pilot hub.

1. Tighten converter housing drain plug to 28-30 N-m (21-22 lb-ft).
2. Proper installation of the torque converter (7902) requires full engagement of the converter hub in the pump gear. To accomplish this, the torque converter must be pushed and at the same time rotated through what feels like two "notches" or bumps.

DIMENSION A TO BE 10.23-14.43 mm (7/16-9/16 INCH) APPROXIMATELY

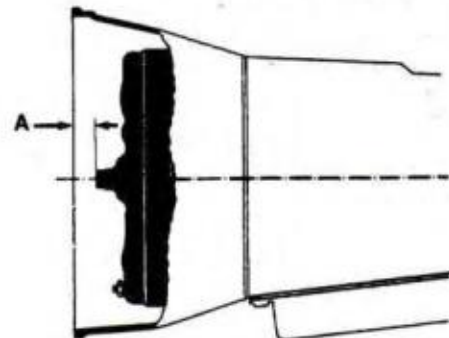

3. With torque converter properly installed, place transmission on jack and secure with safety chain and install Torque Converter Holding Tool T97T-7902-A.
4. Rotate the torque converter so the drive studs and converter housing access plug (7N171) are in alignment with their holes in the flywheel (6375).
5. **CAUTION: The converter housing is piloted into position by dowels in the rear of the engine block. The torque converter must rest squarely against the flywheel. This indicates that the converter pilot is not binding in the engine crankshaft (6303).**  
Align the orange balancing marks on converter stud and flywheel bolt hole if balancing marks are present.
6. With the transmission mounted on a transmission jack, move the torque converter and transmission assembly forward into position being careful not to damage the flywheel and the converter pilot. The torque converter face must rest squarely against the flywheel. This indicates that the converter pilot is not binding in the engine crankshaft.
7. Remove the Torque Converter Holding Tool T97T-7902-A.

**INSTALLATION (Continued)**

8. **NOTE:** Before installing the torque converter housing-to-flywheel retaining nut, a check should be made to make sure that the torque converter is properly seated. The torque converter should move freely with respect to the flywheel. Grasp the stud. Movement back and forth should result in a metallic clank noise if the converter is properly seated. If the torque converter will not move, the transmission must be removed and the torque converter repositioned so that the impeller hub is properly engaged in the pump gear.
- Install two converter housing-to-engine retaining bolts at the engine dowel locations. Tighten to 55-68 N·m (41-50 lb-ft).
9. Install the remaining converter housing-to-engine retaining bolts and tighten to 55-68 N·m (41-50 lb-ft).
10. Remove the safety chain from the automatic transmission/transaxle (A/T)(7000).
11. Install the fluid filler tube and secure it to the cylinder blocks (6010) with the retaining bolt. Tighten the bolt to 38-51 N·m (28-37 lb-ft). If the fluid filler tube is loose in the case, it should be replaced.
12. Install the cooler tubes to the transmission case (7005). Tighten lines to 20-26 N·m (15-19 lb-ft).
13. Remove the jack supporting the front of the engine.
14. Raise the transmission. Position the engine and transmission support insulator (6F063) and engine and transmission support (6F065) and engine damper mounting body bracket (6F067) to the frame side supports and install the retaining bolts. Refer to Section 02-03.
15. Lower the transmission and install the rear engine support-to-crossmember nut. Refer to Section 02-03.
16. Remove the transmission jack.
17. Connect the transmission wiring harness.
18. Install the starter motor (11002). Refer to Section 03-06.
19. Install four flywheel-to-converter retaining nuts. Tighten to 27-46 N·m (20-33 lb-ft).
20. Install converter access cover and cover plate bolts on engine oil pan (6675). Tighten to 16-22 N·m (12-16 lb-ft).
21. Install exhaust system. Refer to Section 09-00.
22. Install the vehicle speed sensor (VSS)(9E731) and connect wiring.
23. Install the driveshaft (4602). Refer to Section 05-01.
24. Remove safety stands and lower the vehicle. Connect the battery ground cable (14301). Refer to Section 14-01.
25. Fill transmission to specification. Start engine and add fluid as required to achieve the proper fluid level as specified.

26. Check the transmission, torque converter assembly and oil cooler tubes for leaks.

**CLEANING AND INSPECTION****Transmission**

Clean all parts with suitable solvent and use moisture-free air to dry off all parts and clean out fluid passages.

**NOTE:** The composition clutch plates, bands and synthetic seals should not be cleaned in a vapor degreaser or with any type of detergent solution.

To clean these parts, wipe with a lint-free cloth. New clutch plates or bands should be soaked in the specified transmission fluid for 15 minutes before assembly.

**Main Control Valve Body**

1. Clean all parts, except non-metallic coating booster valve shuttle balls (7E195), thoroughly in clean solvent and blow dry with moisture-free compressed air.
2. **NOTE:** If necessary, use crocus cloth to polish valves and plungers. Avoid rounding sharp edges of valves and plungers with crocus cloth.  
  
Inspect all valve and plunger bores for scores. Check all fluid passages for obstructions. Inspect all mating surfaces for burrs and scores.
3. Inspect all springs for distortion. Check all valves and plungers for free movement in their respective bores. Valves and plungers, when dry, must fall from their own weight in their respective bores.
4. Roll manual control valve on a flat surface to check for bent condition.

**Converter and Cooler**

When internal wear or damage has occurred in the transmission, metal particles, clutch plate material or band material may have been carried into the torque converter (7902) and transmission fluid cooler (7A095). These contaminants are a major cause of recurring transmission troubles and must be removed from the system before the transmission is put back into service.

Whenever a transmission has been disassembled to replace worn or damaged parts or because the valve body sticks from foreign material, the torque converter and transmission fluid cooler must be cleaned by using a mechanically agitated cleaner, such as Rotunda Torque Converter and Oil Cooler Cleaner 014-00028 or equivalent.

Flush the torque converter of the remaining solvent using this procedure:

**CLEANING AND INSPECTION (Continued)**

1. Thoroughly drain the remaining solvent through the converter housing access plug (7N171).
2. Add 1.9 liter (2 qt) of clean transmission fluid to the torque converter. Agitate by hand.
3. Thoroughly drain the solution through the converter housing access plug.

**Transmission Fluid Cooler—Backflushing / Cleaning**

1. Perform backflushing with a Rotunda Torque Converter Cleaner 014-00028 or equivalent. Test your equipment to make sure that a vigorous fluid flow is present before proceeding. Replace the system filter if flow is weak or contaminated.
2. To aid in attaching the cleaner to the transmission steel cooler tubes, connect two additional rubber hoses to the transmission end of the steel transmission cooler tubes as described below.
  - Connect the cleaner tank pressure line to the steel transmission cooler return tube (longer tube).
  - Connect a tank return hose to the steel transmission cooler pressure tube (shorter tube). Place the outlet end of this hose in the solvent tank reservoir.
3. Turn on solvent pump and allow the solvent to circulate a minimum of five minutes (cycling switch on and off will help dislodge contaminants in cooler system).
4. Switch off the solvent pump and disconnect the solvent pressure hose from the transmission cooler return tube.
5. Use compressed air to blow out the cooler(s) and tube (blow air into the transmission cooler return tube) until all solvent is removed.
6. Remove the rubber return hose from the remaining steel cooler tube.

**Forward, Direct, Intermediate, Overdrive and Reverse Clutches**

1. Inspect clutch cylinder thrust surfaces, piston bore and clutch plate serrations for scores or burrs. Minor scores or burrs may be removed with crocus cloth. Replace clutch cylinder if badly scored or damaged.
2. Check fluid passage in clutch cylinder for obstructions. Clean out all fluid passages. Inspect clutch piston for scores and replace if necessary. Inspect check balls for freedom of movement and proper seating.
3. Check clutch release spring for distortion and cracks. Replace spring (including wave spring) if distorted or cracked.

4. Inspect composition clutch plates, steel clutch plates and clutch pressure plate for worn or scored bearing surfaces. Replace all parts that are deeply scored or burred.
5. Check clutch plates for flatness and fit on clutch hub serrations. Discard any plate that does not slide freely on serrations or that is not flat.
6. Check clutch hub thrust surfaces for scores and clutch hub splines for wear.

**One-Way Clutch**

1. Inspect outer and inner races for scores or damaged surface areas where rollers contact races.
2. Inspect rollers and springs for excessive wear or damage.
3. Inspect spring and cage for bent or damaged spring retainers.

**Output Shaft**

1. Inspect output shaft bearing surfaces for scores. If excessive clearance or scores are found, replace output shaft (7060) and inspect components.
2. Check splines on output shaft for wear. Replace output shaft if splines are excessively worn. Inspect all bushings.

**Electrical Connectors**

Anytime an electrical connector is disconnected, inspect the connector for terminal condition, corrosion and contamination. Also inspect the connector seal for damage. Clean, service or replace as required.

**Case**

Inspect case (7005) for cracks and stripped threads. Inspect gasket surfaces and mating surfaces for burrs. Check vent for obstruction, and check all fluid passages for obstructions and leakage.

Inspect case bushing for scores. Check all parking linkage parts for wear or damage.

**Planet Assemblies**

1. NOTE: Individual parts of the planet assemblies are not serviceable.

Check pins and shafts in planet assemblies for loose fit and / or complete disengagement. Use new planet assembly if either condition exists.

**CLEANING AND INSPECTION (Continued)**

2. Inspect pinion gears for damaged or excessively worn teeth.

3. Check for free rotation of pinion gears.

**Thrust Bearings**

Wash thrust bearings thoroughly in cleaning solvent. Blow bearings dry with compressed air.

Make certain bearings are clean and then lubricate with transmission fluid. Replace any bearings and races which show signs of pitting or roughness. Thrust bearings should not be disassembled. Therefore, pitting is not visible. If any thrust bearing feels rough after proper cleaning and lubrication, it should be replaced. Disassembled thrust bearings should never be reused.

**SPECIFICATIONS****AUTOMATIC TRANSMISSION REFILL CAPACITY**

Liters	Quarts
13.2	13.9

**STALL SPEED SPECIFICATIONS**

Engine	Stall Speed (rpm)	
	Minimum	Maximum
3.8L	1880	2210
4.6L (2V)	2012	2375

**Checks and Adjustments**

NOTE: Transmission end play can be adjusted using one of the selective thrust washers available for service. After measuring the depth, install the required thrust washer.

**TORQUE CONVERTER END PLAY**

New or Rebuilt	Used
0.36-1.04 mm (0.014-0.041 inch)	0.36-1.88 mm (0.014-0.074 inch) max

**SELECTIVE SNAP RINGS**

Clutch	Steel	Friction	Clearance	Selective Snap <sup>®</sup> Rings-Thickness
Forward Clutch	5 <sup>b</sup>	5	1.27-2.38 mm (0.050-0.094 inch)	1.88-1.98 mm (0.074-0.078 in) 2.24-2.34 mm (0.088-0.092 in) 2.59-2.69 mm (0.102-0.106 in)
Reverse Clutch	3	4	1.02-1.91 mm (0.040-0.075 inch)	1.88-1.98 mm (0.074-0.078 in) 2.24-2.34 mm (0.088-0.092 in) 2.59-2.64 mm (0.102-0.106 in)
Direct Clutch	6	6	5 Plate: 1.27-1.80 mm (0.050-0.071 inch) 6 Plate: 1.57-2.16 mm (0.062-0.085 inch)	1.27-1.37 mm (0.050-0.054 in) 1.63-1.73 mm (0.064-0.068 in) 1.98-2.08 mm (0.078-0.082 in) 2.34-2.44 mm (0.092-0.096 in)

(Continued)

## SPECIFICATIONS (Continued)

## SELECTIVE SNAP RINGS (Cont'd)

Clutch	Steel	Friction	Clearance	Selective Snap® Rings-Thickness
Intermediate Clutch	3 <sup>c</sup>	3 <sup>d</sup>	41.504-41.808 mm (1.644-1.661 inch)	1.70-1.80 mm (0.067-0.071 in) 1.96-2.06 mm (0.077-0.081 in) 2.21-2.31 mm (0.087-0.091 in)

- a Selective steel plates for intermediate clutch.  
 b Plus a waved plate (installed next to piston).  
 c Includes selective steel plates.  
 d Must use three friction plates.

REVERSE SERVO PISTON TRAVEL<sup>a</sup>

mm	Inch
2.845-6.020	0.112-0.237

- a. Piston travel can be adjusted using one of the selective servo pistons available for service.

## SELECTIVE SERVO PISTONS

Rod Length <sup>a</sup>	I.D.
74.56 mm (2.936 inch)	1 Groove
75.92 mm (2.989 inch)	2 Groove
77.29 mm (3.043 inch)	3 Groove

- a Measured from the piston surface to the end of the rod.

SELECTIVE THRUST WASHERS<sup>a</sup>

Depth	Thickness	Color Code
36.7342-38.1838 mm (1.4856-1.5033 inch)	1.217-1.371 mm (0.050-0.054 inch)	Green
38.1864-38.641 mm (1.5034-1.5213 inch)	1.727-1.828 mm (0.068-0.072 inch)	Yellow
38.6436-39.0728 mm (1.5214-1.5383 inch)	2.159-2.260 mm (0.085-0.089 inch)	Natural
39.0754-39.5046 mm (1.5384-1.5553 inch)	2.590-2.692 mm (0.102-0.106 inch)	Red
39.5072-40.1396 mm (1.5554-1.5803 inch)	3.022-3.124 mm (0.119-0.123 inch)	Blue

- a. The thrust washer is located on the stator support which is attached to the back of the pump housing.

## LUBRICANT/ADHESIVE/CLEANER SPECIFICATIONS



Description	Part Number	Ford Specification
Pipe Sealant with Teflon <sup>a</sup>	D8AZ-19554-A	WSK-M2G350-AZ
Motorcraft MERCON <sup>®</sup> Multi-Purpose (ATF) Transmission Fluid	XT-2-QDX	MERCON

## TORQUE SPECIFICATIONS

Description	N-m	Lb-Ft	Lb-In
Extension Housing Bolts	25-30	19-22	—
Pan Retaining Bolts	12-15	—	106-132
Stator Support-to-Pump Body	20-26	15-19	—
Main Control Bolts	9-11	—	80-97
Crossmember-to-Transmission	87-110	65-81	—
Converter-to-Flywheel Nuts	27-46	20-33	—
Converter Housing Drain Plug	28-30	21-22	—
Converter Housing-to-Engine Bolts	55-68	41-50	—
Cooler Tube Nut to Fitting	20-26	15-19	—
Cooler Fitting to Case	24-31	18-22	—
Front Pump-to-Case	20-26	15-19	—
TCC Solenoid-to-Main Control	9-11	—	80-97
Reinforcement Plates-to-Main Control	9-11	—	80-97
Cover Plate-to-Valve Body	9-11	—	80-97
Main Control Guide Pin Bolts	9-11	—	80-97
Pressure Tap Plugs	8-16	—	71-141
Output Shaft Speed Sensor	7-10	—	62-88
Manual Lever-to-Case	26-37	20-27	—
TR Sensor Bolts	7-10	—	62-88
Vehicle Speed Sensor (VSS) Retaining Bolt	7-10	—	62-88
Converter Access Cover Plate Bolts	16-22	12-16	—
Fluid Filler Tube Bolt	38-51	28-37	—
Manual Control Valve Detent Lever Spring Bolt	11-15	—	98-132
Transmission Linkage Adjustment Nut	19-26	14-19	—
Electronic Pressure Control Solenoid EPC	11-15	—	98-132



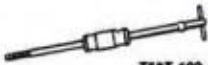
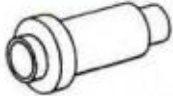







## SPECIAL SERVICE TOOLS/EQUIPMENT

## SPECIAL SERVICE TOOLS REQUIRED

Tool Number/ Description	Illustration
T50T-100-A Impact Slide Hammer	 T50T-100-A
T57L-500-B Bench Mounted Holding Fixture	 T57L-500-B
T59L-100-B Impact Slide Hammer	 T59L-100-B
T61L-7657-B Extension Housing Seal Replacer	 T61L-7657-B
T63L-77837-A Front Pump Seal Replacer	 T63L-77837-A
T65L-77515-A Clutch Spring Compressor	 T65L-77515-A
T68P-7D158-A Lip Seal Protector	 T68P-7D158-A
T74P-77248-A Seal Remover	 T74P-77248-A
T74P-77498-A Shift Lever Seal Replacer	 T74P-77498-A
T76L-7902-C Converter Clutch Torquing Tool	 T76L-7902-C







(Continued)

## SPECIAL SERVICE TOOLS REQUIRED (Cont'd)

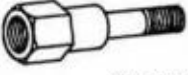

Tool Number/ Description	Illustration
T77F-1102-A Bearing Cup Puller	 T77F-1102-A
T77L-7697-A Extension Housing Bushing Remover	 T77L-7697-A
T77L-7902-R Converter Clutch Holding Tool	 T77L-7902-R
T80L-7902-A End Play Checking Tool	 T80L-7902-A
T80L-77003-A Gauge Bar	 T80L-77003-A
T80L-77030-A Servo Piston Selection Tool	 T80L-77030-A
T80L-77034-A Extension Housing Bushing Replacer	 T80L-77034-A
T80L-77110-A Case Rear Bushing Replacer	 T80L-77110-A
T80L-77140-A Forward Clutch Lip Seal Protector	 T80L-77140-A
T80L-77234-A Direct Clutch Inner Lip Seal Protector	 T80L-77234-A

(Continued)

**SPECIAL SERVICE TOOLS / EQUIPMENT  
(Continued)**

SPECIAL SERVICE TOOLS REQUIRED (Cont'd)	
Tool Number/ Description	Illustration
T80L-77254-A Direct Clutch Outer Lip Seal Protector	 T80L-77254-A
T80L-77403-A Reverse Clutch Outer Seal Protector	 T80L-77403-A
T80L-77403-B Reverse Clutch Inner Seal Protector	 T80L-77403-B
T80L-77405-A Reverse Clutch Spring Compressor	 T80L-77405-A
T81P-70235-A Direct Clutch Spring Compressor	 T81P-70235-A
T89T-70010-A Pump Puller Adapters	 T89T-70010-A
T92P-7006-A AODE Transmission Test Plate T92P-7006-A1 Replacement Gasket	 T92P-7006-A
T92P-70023-A Servo Piston Remover / Replacer	 T92P-70023-A

(Continued)

SPECIAL SERVICE TOOLS REQUIRED (Cont'd)	
Tool Number/ Description	Illustration
T93P-70010-A Transmission Range Sensor Alignment Tool (MLPS Alignment Tool)	 3P70010A
T95L-77005-A Intermediate Clutch Piston Seal Protector	 T95L-77005-A
T97T-7902-A Torque Converter Holding Tool	 ST1636-A

SPECIAL SERVICE TOOLS DESIRED	
Tool Number	Description
D80P-4201-A	Depth Micrometer
D93L-7000-A	Rubber-Tipped Air Gun
TOOL-1175-AC	Seal Remover
TOOL-4201-C	Dial Indicator with Bracketry

ROTUNDA EQUIPMENT	
Model	Description
007-00130	Transmission Tester
007-00122	AODE / 4R70W Cable and Overlay
007-00128	MLP-C Cable AODE / 4R70W 93 and Up; 4R44E / 4R55E 93 and Up
007-00500	New Generation Star (NGS) Tester
014-00028	Torque Converter / Oil Cooler Cleaner
014-00950	104-Pin Breakout Box
014-R1075	Rotunda Leak Check Tool and Gasket
105-R0051	73 Digital Multimeter

ProCarManuals.com

# SECTION 07-02 Transmission, Automatic—Cooling

SUBJECT	PAGE	SUBJECT	PAGE
VEHICLE APPLICATION .....	07-02-1	REMOVAL AND INSTALLATION	
DESCRIPTION AND OPERATION		Fluid Cooler Tube .....	07-02-6
Fluid Cooler, Integral .....	07-02-1	CLEANING AND INSPECTION	
DIAGNOSIS AND TESTING		Transmission Fluid Cooler and Tubes .....	07-02-6
Component Tests .....	07-02-5	SPECIFICATIONS .....	07-02-6
Inspection and Verification .....	07-02-5	SPECIAL SERVICE TOOLS/EQUIPMENT .....	07-02-7
Symptom Chart.....	07-02-5		

**VEHICLE APPLICATION**  
Thunderbird, Cougar

## DESCRIPTION AND OPERATION

### Fluid Cooler, Integral

The transmission fluid cooler is integral to the radiator (8005). Whenever leaks or damage to the radiator are found, replace the entire radiator. Refer to Section 03-03.

ProCarManuals.com

DESCRIPTION AND OPERATION (Continued)

Transmission Fluid Cooler System—3.8L Engine

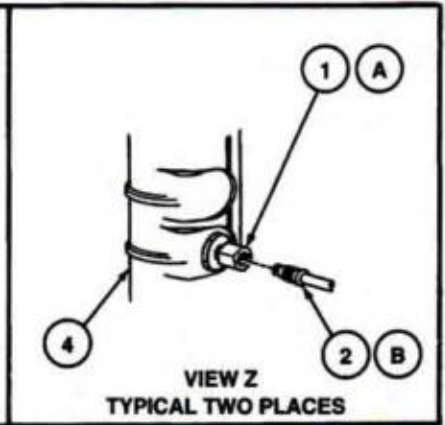
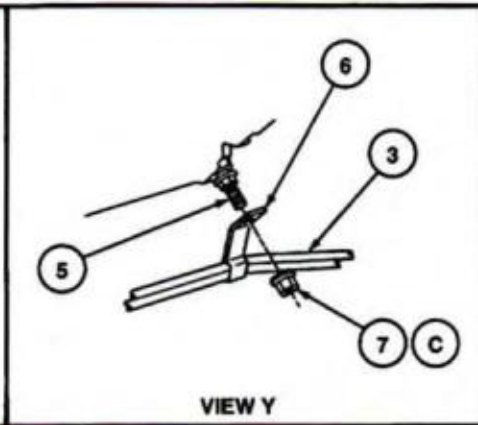
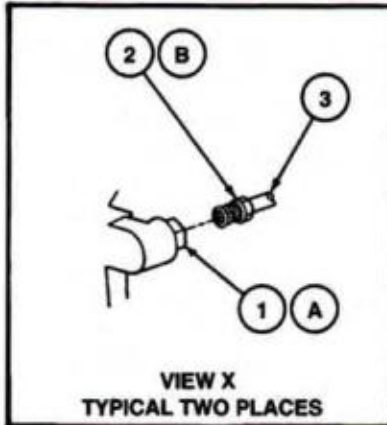
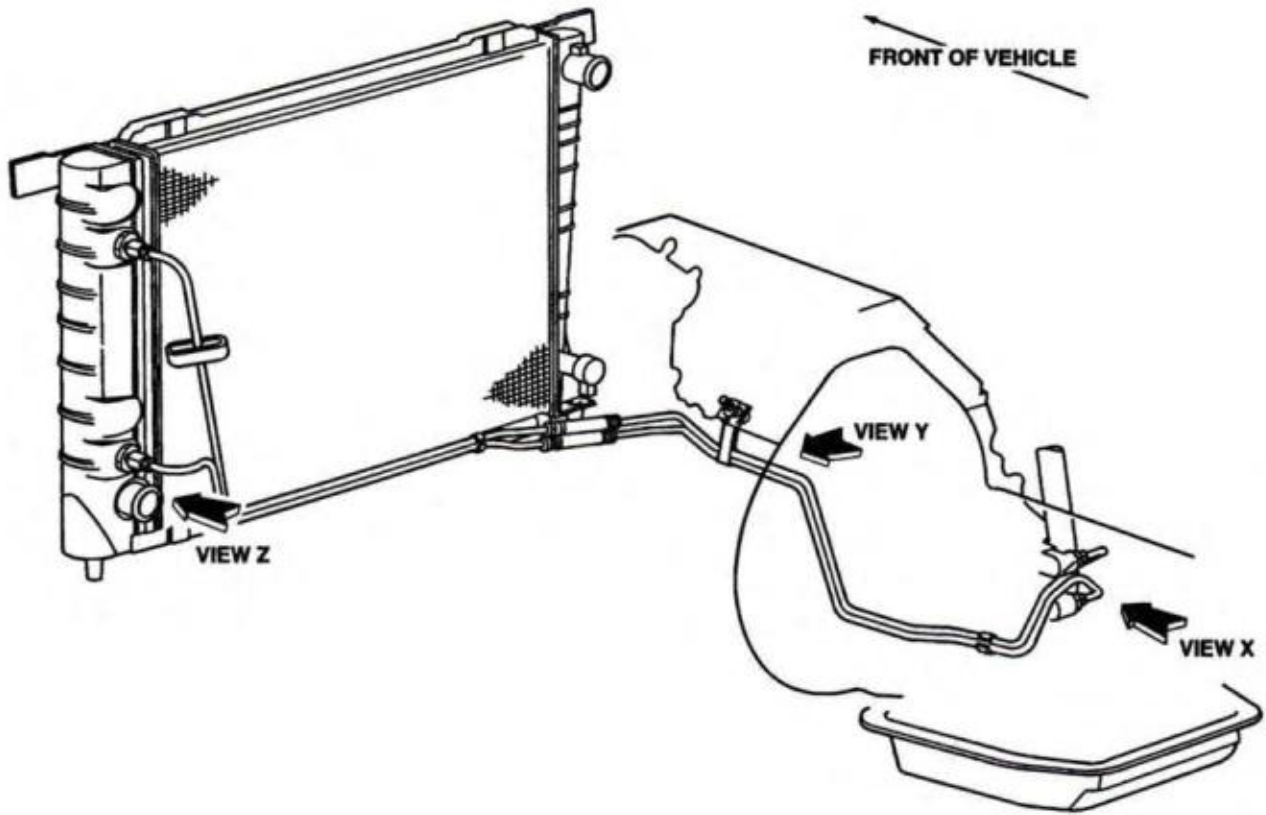

D14634-B

Item	Part Number	Description
1	7D273	Transmission Tube Connector
2	87944-S56	Tube Nut

(Continued)

Item	Part Number	Description
3	7A031	Transmission Fluid Cooler Tube
4	8005	Radiator
5	—	Engine Mount Stud

(Continued)

## DESCRIPTION AND OPERATION (Continued)

Item	Part Number	Description
6	7N291	Transmission Fluid Cooler Line Clip
7	N620482-S56	Nut
A	—	Tighten to 16-20 N-m (12-14 Lb-Ft)

(Continued)

Item	Part Number	Description
B	—	Tighten to 17-23 N-m (13-16 Lb-Ft)
C	—	Tighten to 40-55 N-m (30-40 Lb-Ft)

DESCRIPTION AND OPERATION (Continued)

Transmission Fluid Cooler System—4.6L Engine

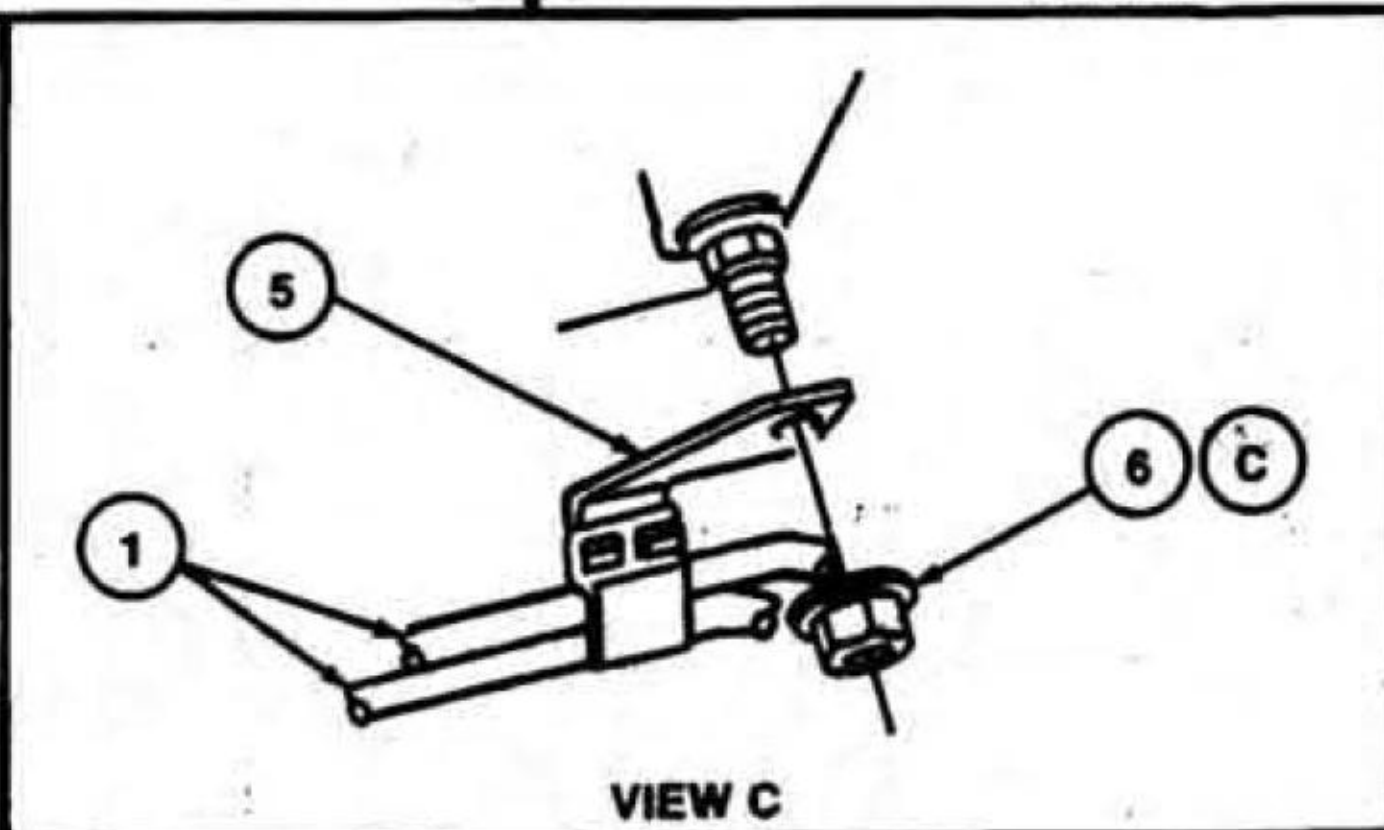
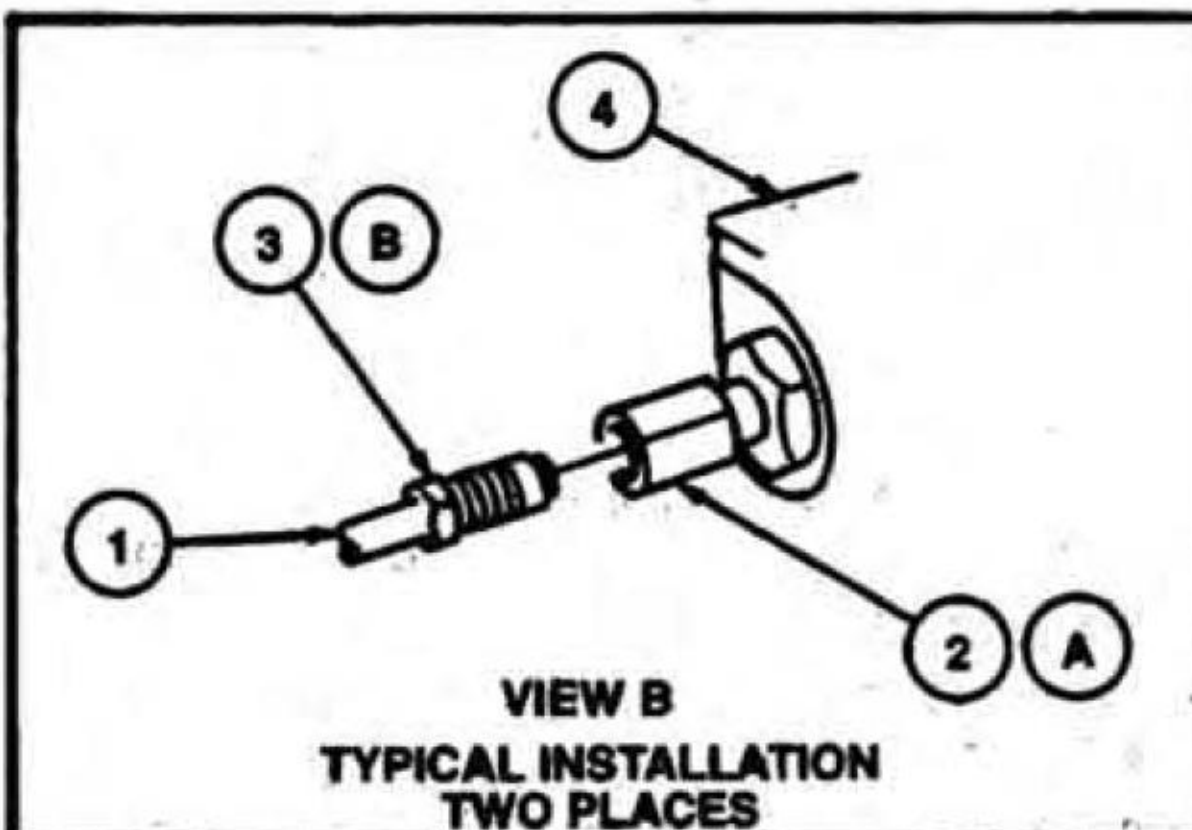
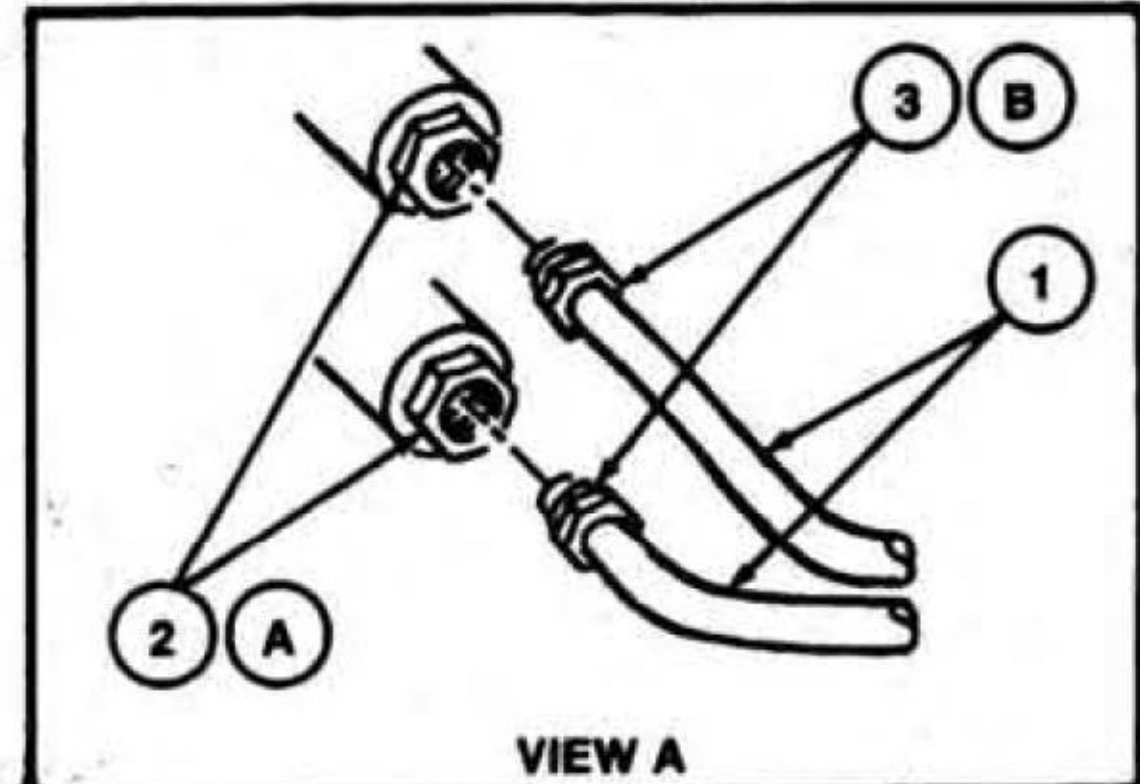
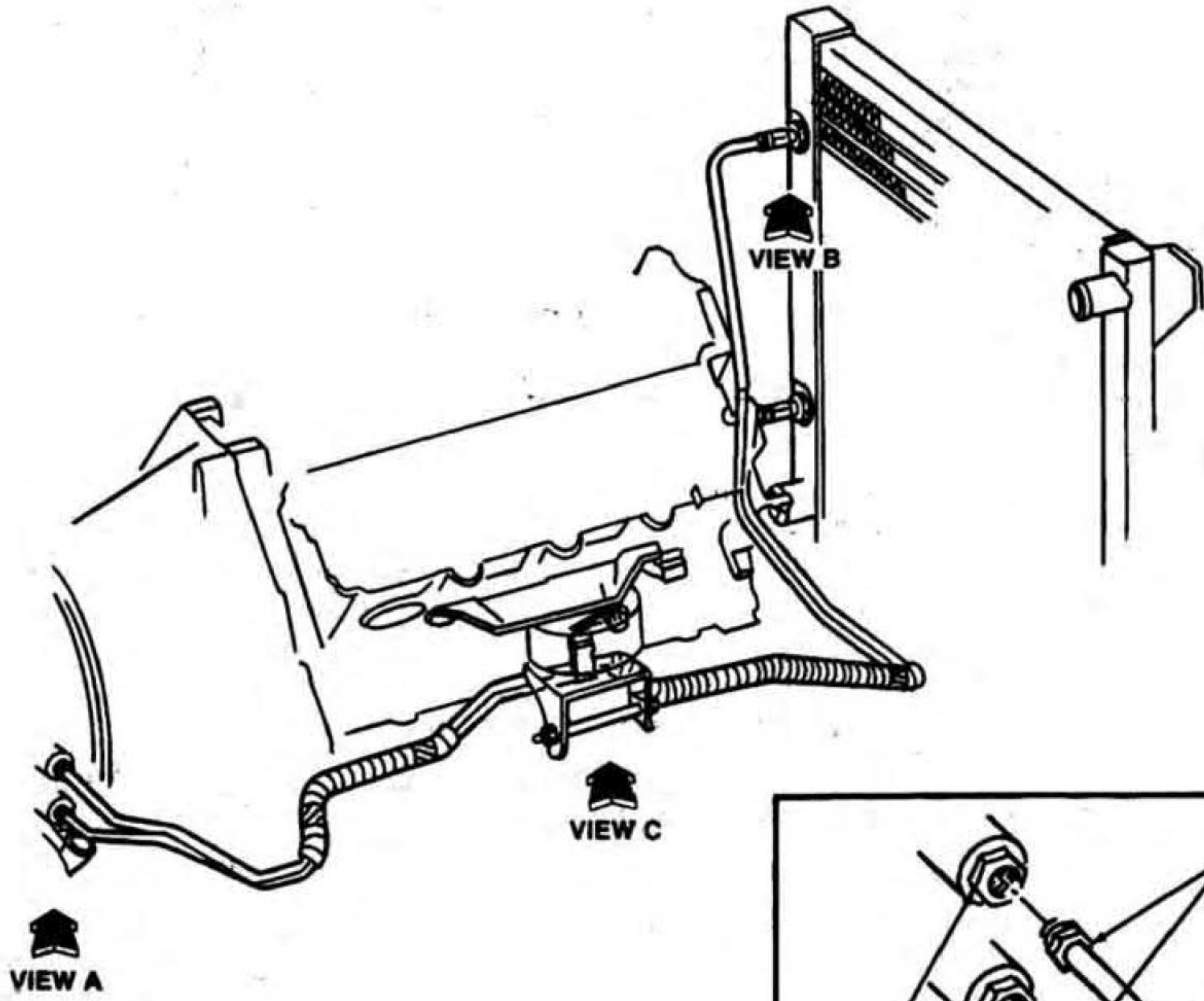

D16311-A

ProCarManuals.com

## DESCRIPTION AND OPERATION (Continued)

Item	Part Number	Description
1	7A031	Transmission Fluid Cooler Tube
2	7D273	Transmission Fluid Tube Connector
3	87944-S56	Tube Nut
4	8005	Radiator
5	7N291	Transmission Fluid Cooler Line Clip

(Continued)

Item	Part Number	Description
6	N620482-S56	Nut
A	—	Tighten to 16-20 N-m (12-14 Lb-Ft)
B	—	Tighten to 17-23 N-m (13-16 Lb-Ft)
C	—	Tighten to 40-55 N-m (30-40 Lb-Ft)

## DIAGNOSIS AND TESTING

## Inspection and Verification

When transmission fluid leakage is found in radiator (8005), replace radiator. Refer to Section 03-03.

## Symptom Chart

## AUTOMATIC TRANSMISSION COOLING

Condition	Possible Source	Action
<ul style="list-style-type: none"> <li>Transmission Overheating</li> </ul>	<ul style="list-style-type: none"> <li>Damaged radiator.</li> <li>System leaks.</li> <li>Improper fluid level.</li> <li>Fluid condition.</li> <li>Damaged, blocked, reversed, leaking, or restricted cooler lines cooler tubes.</li> <li>Engine concerns causing transmission to overheat.</li> <li>Excessive towing loads.</li> <li>Incorrect idle or performance.</li> <li>Heat shields missing or damaged.</li> </ul>	<ul style="list-style-type: none"> <li>SERVICE as necessary. REFER to Section 03-03.</li> <li>INSPECT for leaks. SERVICE as described.</li> <li>ADJUST to proper level.</li> <li>INSPECT according to instructions under Fluid Level Condition Check. REFER to Section 07-01.</li> <li>INSPECT and FLUSH cooler lines as described. SERVICE as required.</li> <li>REFER to Section 03-03.</li> <li>CHECK gross vehicle weight.</li> <li>REFER to Powertrain Control/Emissions Diagnosis Manual<sup>1</sup>.</li> <li>INSPECT and SERVICE as required.</li> </ul>

## Component Tests

## Transmission Fluid Cooler Flow Check

NOTE: The transmission linkage adjustment, fluid level and line pressure must be within specification before performing this test. Refer to Section 07-05.

- Remove fluid level indicator from fluid filler tube.
- Place a funnel in filler tube.
- Raise vehicle on hoist and position suitable safety stands under vehicle.
- Remove cooler return line (rear fitting) from fitting on transmission case.

- Connect one end of a hose to the cooler return line and route the other end of the hose up to a point where it can be inserted into a funnel at the fluid filler tube.
- Remove safety stands and lower vehicle. Insert end of hose into funnel.
- Start engine and run at idle with transmission in neutral position.
- When fluid flowing from hose is all liquid, an adequate amount of fluid should be observed (approximately 1 liter (1 quart) delivered in 30 seconds). If adequate flow is observed, test is complete.

<sup>1</sup> Can be purchased as a separate item.

**DIAGNOSIS AND TESTING (Continued)**

9. If flow is not adequate, stop engine. Disconnect hose from cooler return line and connect it to converter - out line (front fitting) on case.
10. Repeat Steps 7 and 8. If flow is now approximately 1 liter (1 quart) in 30 seconds, perform Transmission Fluid Cooler—Backflushing / Cleaning. Refer to Section 07-01. If flow is still not approximately 1 liter (1 quart) in 30 seconds, service the pump and / or converter. Refer to Section 07-01.

**REMOVAL AND INSTALLATION****Fluid Cooler Tube****Removal and Installation**

1. If leakage is noted at cooler tube fitting on the transmission or radiator (8005), unscrew the tube nut while holding the fitting in the transmission or radiator with a wrench.
2. Install a 1/4 x 18 straight thread connector into the transmission case (7005) or a 1/4 x 18 tapered thread connector into radiator, using thread sealer or Teflon® tape on the male threads of the connector. Tighten to 16-20 N·m (12-14 lb-ft).
3. Install tube nut into connector. Tighten to 17-23 N·m (13-16 lb-ft).
4. If transmission fluid cooler line clip removal was necessary, tighten bolt to 40-55 N·m (30-40 lb-ft).

**CLEANING AND INSPECTION****Transmission Fluid Cooler and Tubes**

When internal wear or damage has occurred in the transmission, metal particles, clutch plate material or band material may have been carried into the torque converter (7902) and radiator (8005). These contaminants are a major cause of recurring transmission troubles and must be removed from the system before the transmission is put back into service.

Whenever a transmission has been disassembled to replace worn or damaged parts, the radiator must be cleaned by using a mechanically-agitated cleaner, such as Rotunda Torque Converter / Oil Cooler Cleaner 014-00028 or equivalent.

Inspect cooler tubes and fittings for damage and leaks. Tighten fittings to specification. If leak persists, replace fittings and tubes as necessary.

When one or more of the transmission fluid cooler tubes must be replaced, each replacement tube must be fabricated from the same size steel tubing as the original tube.

Using the old tube as a guide, bend the new tube as required. Add the necessary fittings and install the tube.

After the fittings have been tightened to specification, add Motorcraft MERCON® Multi-Purpose (ATF) Transmission Fluid XT-2-QDX or equivalent meeting Ford MERCON® specification as necessary and check for fluid leaks.

Whenever a transmission has been disassembled to replace worn or damaged parts or when fluid contamination is suspected, the following procedure should be used:

1. Conduct backflushing with a Rotunda Torque Converter / Oil Cooler 14-00028 or equivalent. Test your equipment to make sure that a vigorous fluid flow is present before proceeding. Replace the system filter if flow is weak or contaminated.
2. To aid in attaching the cleaner to the transmission steel cooler tubes, connect two additional rubber hoses to the transmission end of the steel transmission cooler tubes as described below.
  - Connect the cleaner tank pressure line to the steel transmission cooler return tube (longest tube).
  - Connect a tank return hose to the steel transmission cooler pressure tube (shorter tube). Place the outlet end of this hose in the solvent tank reservoir.
3. Turn on solvent pump and allow the solvent to circulate a minimum of five minutes (cycling switch on and off will help dislodge contaminants in cooler system).
4. Switch off the solvent pump and disconnect the solvent pressure hose from the transmission cooler return tube.
5. Use compressed air to blow out the cooler(s) and tubes (blow air into the transmission cooler return tube) until all solvent is removed.
6. Remove the rubber return hose from the remaining steel cooler tube.

**SPECIFICATIONS****LUBRICANT / ADHESIVE / CLEANER SPECIFICATIONS**

Description	Part Number	Ford Specification
Motorcraft MERCON® Multi-Purpose ATF Transmission Fluid	XT-2-QDX	MERCON®

**TORQUE SPECIFICATIONS**

Description	N·m	Lb·Ft
Fluid Cooler Line Clip to Engine Mount Nut	40-55	30-40
Fluid Cooler Tube Connector	16-20	12-14
Fluid Cooler Tube Nuts	17-23	13-16

**SPECIAL SERVICE TOOLS/EQUIPMENT**

ROTUNDA EQUIPMENT	
Model	Description
014-00028	Torque Converter / Oil Cooler Cleaner

# SECTION 07-05 Transmission, Automatic—External Controls

SUBJECT	PAGE	SUBJECT	PAGE
VEHICLE APPLICATION .....	07-05-1	REMOVAL AND INSTALLATION (Cont'd.)	
DESCRIPTION AND OPERATION		Transmission Range (TR) Sensor .....	07-05-8
Shift Control Linkage .....	07-05-1	Transmission Range Indicator Lamp Bulb, Floor Shift .....	07-05-8
Shift Interlock System .....	07-05-1	Transmission Range Selector Lever .....	07-05-5
Transmission Control Switch .....	07-05-2	Transmission Shift Cable and Bracket .....	07-05-7
DIAGNOSIS AND TESTING		CLEANING AND INSPECTION	
Electrical Schematics .....	07-05-2	Brake / Shift Interlock System .....	07-05-8
Transmission, Automatic—External Controls .....	07-05-2	Transmission Range Selector Lever .....	07-05-8
Inspection and Verification .....	07-05-2	ADJUSTMENTS	
Pinpoint Tests .....	07-05-3	Transmission Shift Control Cable and Bracket .....	07-05-8
Symptom Chart .....	07-05-2	SPECIFICATIONS .....	07-05-9
REMOVAL AND INSTALLATION		SPECIAL SERVICE TOOLS/EQUIPMENT .....	07-05-9
Bezel, Transmission Control Selector Dial .....	07-05-5		
Ignition / Shifter Interlock Cable .....	07-05-6		

## VEHICLE APPLICATION

Thunderbird, Cougar

## DESCRIPTION AND OPERATION

### Shift Control Linkage

The transmission range selector control linkage consists of the following components:

- a floor-mounted transmission range selector lever
- a transmission control switch on the transmission range selector lever
- a cable connecting the transmission range selector lever to the transmission
- a brake / shifter interlock system
- an ignition / shifter interlock cable (3F7 19) to the steering column lock assembly

### Shift Interlock System

A brake / shifter interlock mechanism prevents shifting the transmission out of the PARK position unless the brake pedal is applied. The system consists of the following components:

- an actuator assembly attached to the key interlock assembly
  - necessary wiring
  - It also requires the transmission range lever selector to be in the PARK position to turn the ignition switch to the LOCK position.
- The system operates as follows:
- The actuator is energized when the ignition switch is turned to the RUN position. This locks the shifter in the PARK position. When the brake pedal (2455) is applied and the stoplight switch (13480) is activated, the brake shift lock actuator is deactivated and the selector lever can be moved out of the PARK position.
  - The ignition / shifter interlock cable (3F7 19) locks the transmission range lever selector in the PARK position when the ignition switch is in the LOCK position.

**DESCRIPTION AND OPERATION (Continued)****Transmission Control Switch**

The floor-mounted transmission range selector lever includes a transmission control switch in the transmission range selector lever knob. Operation is as follows:

- The system automatically engages into the OVERDRIVE mode each time the ignition switch is turned to RUN.
- Pressing the transmission control switch with the ignition switch in RUN disengages the OVERDRIVE mode.

- Pressing the transmission control switch once again engages the OVERDRIVE mode.

**DIAGNOSIS AND TESTING****Electrical Schematics**

Refer to Electrical and Vacuum Troubleshooting Manual, Cell 37, Shift Lock for schematic and connector information.

Refer to Electrical and Vacuum Troubleshooting Manual, Cell 29, Transmission Controls (4R70W) for schematic and connector information.

**Transmission, Automatic—External Controls****Inspection and Verification**

1. Visually inspect the components of the transmission range selector linkage and brake shift interlock system.
2. Inspect to determine if one of the following mechanical or electrical concerns apply:

**VISUAL INSPECTION CHART**

Mechanical	Electrical
<ul style="list-style-type: none"> <li>● Damaged or misadjusted selector lever cable.</li> <li>● Damaged ignition key cylinder.</li> <li>● Damaged transmission control switch.</li> </ul>	<ul style="list-style-type: none"> <li>● Open fuse junction panel RUN (5A), STOP LPS (15A) fuse(s).</li> <li>● Damaged brake shift interlock actuator.</li> <li>● Damaged wiring harness.</li> <li>● Loose or corroded connections.</li> </ul>

3. If the inspection reveals obvious concern(s) that can be readily identified, service as required.
4. If the concern(s) remains after the inspection, determine the condition(s) and go to the Symptom Chart.

**Symptom Chart**

Refer to the Electrical and Vacuum Troubleshooting Manual for the connector numbers cited in the pinpoint tests.

Use Rotunda 73 Digital Multimeter 105-R0051 or equivalent to perform pinpoint tests.

**AUTOMATIC TRANSMISSION EXTERNAL CONTROLS**

Condition	Possible Source	Action
<ul style="list-style-type: none"> <li>● Shift Interlock System Does Not Release or Lock Properly</li> </ul>	<ul style="list-style-type: none"> <li>● Circuitry open / shorted.</li> <li>● Open fuse.</li> <li>● Damaged stoplight switch.</li> <li>● Damaged shift lock actuator.</li> </ul>	<ul style="list-style-type: none"> <li>● GO to Pinpoint Test A.</li> </ul>
<ul style="list-style-type: none"> <li>● Shift Control Linkage Binding, Out of Proper Gear Relationship</li> </ul>	<ul style="list-style-type: none"> <li>● Damaged ignition / shifter interlock cable.</li> <li>● Loose ignition / shifter interlock cable.</li> <li>● Loose retainer bracket.</li> <li>● Gearshift linkage misadjusted.</li> </ul>	<ul style="list-style-type: none"> <li>● GO to Pinpoint Test B.</li> </ul>
<ul style="list-style-type: none"> <li>● Transmission Control Indicator Lamp Not Operating Properly</li> </ul>	<ul style="list-style-type: none"> <li>● Damaged transmission control switch.</li> <li>● Circuitry open / shorted.</li> <li>● Open fuse.</li> <li>● Open miniature bulb.</li> <li>● Damaged powertrain control module.</li> </ul>	<ul style="list-style-type: none"> <li>● GO to Pinpoint Test C.</li> </ul>

## DIAGNOSIS AND TESTING (Continued)

## Pinpoint Tests

## PINPOINT TEST A: SHIFT INTERLOCK SYSTEM DOES NOT RELEASE OR LOCK PROPERLY

Test Step	Result	Action to Take
<b>A1</b> CHECK RUN FUSE		
<ul style="list-style-type: none"> <li>CHECK RUN Fuse (5A) located in fuse junction panel.</li> <li>Is fuse OK?</li> </ul>	Yes No	GO to A3. GO to A2.
<b>A2</b> CHECK RESISTANCE OF CIRCUIT 298 (P/O)		
<ul style="list-style-type: none"> <li>Turn ignition switch OFF.</li> <li>Remove RUN Fuse (5A).</li> <li>Disconnect shiftlock actuator connector C209.</li> <li>Measure resistance of Circuit 298 (P/O) and ground.</li> <li>Is resistance greater than 10,000 ohms?</li> </ul>	Yes No	GO to A3. SERVICE Circuit 298 (P/O) for short to ground. RESTORE vehicle. RETEST system.
<b>A3</b> CHECK POWER SUPPLY FROM RUN FUSE (5A)		
<ul style="list-style-type: none"> <li>Reinstall RUN Fuse (5A).</li> <li>Disconnect shiftlock actuator connector C209.</li> <li>Measure voltage on Circuit 298 (P/O) and ground.</li> <li>Turn ignition ON.</li> <li>Is voltage B+?</li> </ul>	Yes No	GO to A4. SERVICE Circuit 298 (P/O) for open. RESTORE vehicle. RETEST system.
<b>A4</b> CHECK STOP LAMP OPERATION		
<ul style="list-style-type: none"> <li>Press brake pedal.</li> <li>Does stoplamp operate?</li> </ul>	Yes No	GO to A5. SERVICE stoplamp circuit. REFER to Section 17-02.
<b>A5</b> CHECK POWER SUPPLY BETWEEN BRAKE PEDAL AND SHIFTLOCK ACTUATOR		
<ul style="list-style-type: none"> <li>Apply brake pedal.</li> <li>Measure voltage on Circuit 511 (LG) and ground.</li> <li>Is voltage B+ with brake pedal applied?</li> </ul>	Yes No	GO to A6. SERVICE Circuit 511 (LG) for open. RESTORE vehicle. RETEST system.
<b>A6</b> MEASURE RESISTANCE IN GROUND CIRCUIT		
<ul style="list-style-type: none"> <li>With C209 disconnected, measure resistance of Circuit 57 (BK) and ground.</li> <li>Is resistance less than 5 ohms?</li> </ul>	Yes No	REPLACE shiftlock actuator. SERVICE Circuit 57 (BK) for open. RESTORE vehicle. RETEST system.

## PINPOINT TEST B: SHIFT CONTROL LINKAGE BINDING, OUT OF PROPER GEAR RELATIONSHIP

Test Step	Result	Action to Take
<b>B1</b> CHECK SHIFT CONTROL LINKAGE		
<ul style="list-style-type: none"> <li>Gain access to transmission range selector lever linkage as described.</li> <li>Actuate transmission range selector lever linkage in all ranges.</li> <li>Observe all linkage during operation.</li> <li>Is linkage damaged?</li> </ul>	Yes No	REPLACE transmission range selector lever linkage. RESTORE vehicle. RETEST system. GO to B2.
<b>B2</b> CHECK SHIFT CONTROL CABLE		
<ul style="list-style-type: none"> <li>Check transmission shift cable and bracket installation and tightness.</li> <li>Is transmission shift cable and bracket properly installed?</li> </ul>	Yes No	ADJUST linkage as described in Adjustments. GO to B3. SERVICE as necessary. RESTORE vehicle. RETEST system.
<b>B3</b> CHECK LINKAGE / CABLE FOR PROPER GEAR RELATIONSHIP		
<ul style="list-style-type: none"> <li>Actuate transmission range selector lever in all ranges.</li> <li>Does indicator match selector lever selection?</li> </ul>	Yes No	SERVICE is complete. RESTORE vehicle. RETEST system. REPLACE damaged linkage / cable. RESTORE vehicle. RETEST system.

## DIAGNOSIS AND TESTING (Continued)

## PINPOINT TEST C: TRANSMISSION CONTROL INDICATOR LAMP NOT OPERATING PROPERLY

Test Step		Result	Action to Take
<b>C1</b>	<b>CHECK SUPPLY VOLTAGE TO TRANSMISSION CONTROL SWITCH</b>		
	<ul style="list-style-type: none"> <li>● Turn ignition switch OFF.</li> <li>● Disconnect C341.</li> <li>● Turn ignition switch to RUN.</li> <li>● Using a voltmeter connected to ground, check voltage at Circuit 298 (P/O).</li> <li>● <b>Is voltage B+?</b></li> </ul>	Yes No	GO to C3. SERVICE RUN Fuse. If fuse is OK, GO to C2.
<b>C2</b>	<b>CHECK RESISTANCE IN CIRCUIT 298 (P/O)</b>		
	<ul style="list-style-type: none"> <li>● Turn ignition switch OFF.</li> <li>● Measure resistance of Circuit 298 (P/O) to ground.</li> <li>● <b>Is resistance greater than 10,000 ohms?</b></li> </ul>	Yes No	SERVICE Circuit 298 (P/O) for open. RESTORE vehicle. RETEST system. SERVICE Circuit 298 (P/O) for short to ground. RESTORE vehicle. RETEST system.
<b>C3</b>	<b>CHECK TRANSMISSION CONTROL SWITCH</b>		
	<ul style="list-style-type: none"> <li>● Using an ohmmeter, measure resistance between switch terminals.</li> <li>● Actuate and hold the transmission control switch.</li> <li>● <b>Is resistance less than 5 ohms with switch closed or greater than 10,000 ohms with switch open?</b></li> </ul>	Yes No	GO to C4. REPLACE transmission control switch. RESTORE vehicle. RETEST system.
<b>C4</b>	<b>CHECK TRANSMISSION CONTROL SWITCH INPUT TO POWERTRAIN CONTROL MODULE</b>		
	<ul style="list-style-type: none"> <li>● Reconnect C341.</li> <li>● Gain access to the powertrain control module.</li> <li>● Turn ignition switch to OFF.</li> <li>● Disconnect C269.</li> <li>● Install Rotunda 104-Pin Breakout Box 014-00950 or equivalent. Leave powertrain control module disconnected.</li> <li>● Turn ignition switch to RUN.</li> <li>● Actuate and hold the transmission control switch.</li> <li>● Using a voltmeter check for voltage at Pin 29, Circuit 224 (T/W) and ground.</li> <li>● <b>Is voltage B+?</b></li> </ul>	Yes No	GO to C6. GO to C5.
<b>C5</b>	<b>CHECK RESISTANCE OF CIRCUIT 224 (T/W)</b>		
	<ul style="list-style-type: none"> <li>● Turn ignition switch OFF.</li> <li>● Using an ohmmeter, measure resistance at breakout box Pin C269-29, Circuit 224 (T/W) to ground.</li> <li>● <b>Is resistance greater than 10,000 ohms?</b></li> </ul>	Yes No	SERVICE Circuit 224 (T/W) for short to ground. RESTORE vehicle. RETEST system. SERVICE Circuit 224 (T/W) for open. RESTORE vehicle. RETEST system.
<b>C6</b>	<b>CHECK RESISTANCE OF CIRCUIT 911 (W/LG)</b>		
	<ul style="list-style-type: none"> <li>● Turn ignition switch OFF.</li> <li>● Using an ohmmeter, measure resistance at Breakout Box Pin C269-29, Circuit 911 (W/LG) to ground.</li> <li>● <b>Is resistance greater than 10,000 ohms?</b></li> </ul>	Yes No	GO to C7. SERVICE Circuit 911 (W/LB) for short to ground. RESTORE vehicle. RETEST system.
<b>C7</b>	<b>CHECK CIRCUIT 911 (W/LG)</b>		
	<ul style="list-style-type: none"> <li>● Reconnect powertrain control module.</li> <li>● Turn ignition switch to RUN.</li> <li>● Actuate and hold the transmission control switch.</li> <li>● Measure voltage on Pin C269-79, Circuit 911 (W/LG).</li> <li>● <b>Is voltage B+ with switch closed?</b></li> </ul>	Yes No	GO to C8. SERVICE Circuit 911 (W/LG) for open. RESTORE vehicle. RETEST system.

## DIAGNOSIS AND TESTING (Continued)

## PINPOINT TEST C: TRANSMISSION CONTROL INDICATOR LAMP NOT OPERATING PROPERLY (Continued)

Test Step		Result	Action to Take
C8	CHECK CIRCUIT 911 (W/LG) FOR SHORT TO GROUND		
	<ul style="list-style-type: none"> <li>● Disconnect C250.</li> <li>● Measure resistance of Circuit 911 (W/LG) between C269 and C250.</li> <li>● Is resistance greater than 5 ohms?</li> </ul>	Yes	SERVICE Circuit 911 (W/LG) for open. RESTORE vehicle. RETEST system.
		No	SERVICE indicator bulb or cluster. REFER to Section 13-01, Inspection and Verification to continue diagnosis.

## REMOVAL AND INSTALLATION

## Transmission Range Selector Lever

## Removal

1. Place transmission range selector lever in DRIVE. Remove console finish panel (04567). Refer to Section 01-12.
2. Remove ignition / shifter interlock cable (3F719) and disconnect cable from range interlock cam.
3. Disconnect transmission range indicator lamp / transmission control switch electrical connector.
4. Raise vehicle on hoist.
5. Remove range cable retaining nut from transmission bracket. Disconnect shift cable and bracket (7E395) from transmission control selector connecting rod adjustment stud (7B415).
6. Lower vehicle. Remove transmission range selector lever and housing retaining bolts and remove transmission range selector lever.

## Installation

1. Install transmission range selector lever to front floor pan (11135) with retaining bolts. Tighten to 6-8 N-m (54-70 lb-in).
2. Connect shift cable and bracket. Tighten retaining screw to 3-4 N-m (27-35 lb-in). Install retaining clip and connect transmission range indicator lamp wire.
3. Install console finish panel.

4. Place the transmission range selector lever in DRIVE and apply a 1.4 kg (3 lb) rearward force to the lever.
5. Raise vehicle on hoist.
6. Connect shift cable and bracket to manual control lever (7A256) and transmission bracket. Make sure manual control lever is in DRIVE and tighten nut at bracket to 13-25 N-m (10-18 lb-ft).
7. Lower vehicle and check range selector for proper operation.

## Bezel, Transmission Control Selector Dial

## Removal

1. Remove transmission control switch using a small screwdriver and gently prying between switch housing and transmission range selector lever knobs.
2. Remove retaining clip from transmission range selector lever knob.
3. Hold transmission range selector lever knob securely and press release button.
4. Pull up on transmission range selector lever knob and remove button and spring from lever knob.
5. Remove console finish panel (04567). Refer to Section 01-12.

## REMOVAL AND INSTALLATION (Continued)

6. Remove transmission control selector dial bezel retaining screws. Raise transmission control selector dial bezel (7D443) and disconnect transmission range indicator lamp connector. Remove transmission control selector dial bezel.

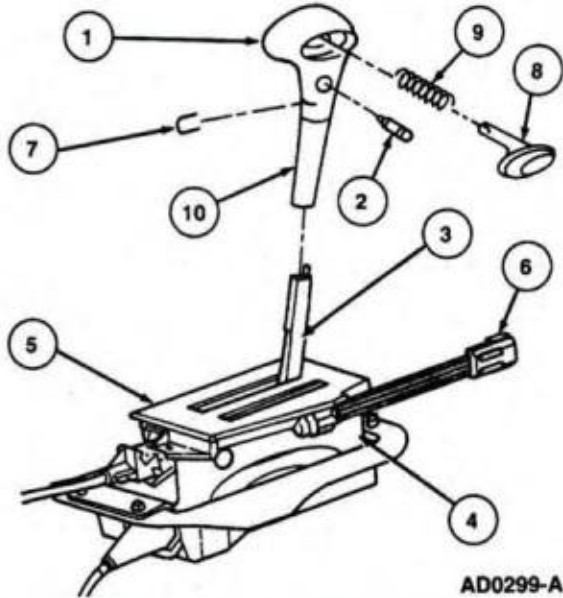

AD0299-A

Item	Part Number	Description
1	7213	Gearshift Lever Knob
2	7G550	Transmission Control Switch
3	—	Transmission Shift Control Selector Lever (Part of 7210)
4	7210	Transmission Range Selector Lever
5	7D443	Transmission Control Selector Dial Bezel
6	—	Transmission Control Switch Wire Harness (Part of 7210)
7	—	Selector Knob Retainer (Part of 7213)
8	7C489	Transmission Range Selector Lever Button
9	7C307	Transmission Range Selector Lever Spring
10	—	Transmission Range Selector Lever Shroud (Part of 7213)

**Installation**

- Replace transmission control selector dial bezel over shift lever while lining up indicator slot with indicator driver.
- Fasten retaining screws and connect the transmission range indicator lamp connector.
- Position transmission range selector lever in PARK.
- Position transmission control switch wiring connector against shift lever notch and hold while sliding transmission range selector lever assembly over transmission control switch wiring connector.
- Install transmission range selector lever assembly into slide opening and press transmission range selector lever knob onto transmission range selector lever firmly.
- Verify transmission range selector lever knob is installed completely onto lever and install retaining clip.
- Install spring and button into selector lever knob.
- Install transmission control switch into transmission range selector lever knob assembly.
- Replace console finish panel. Refer to Section 01-12.
- Check transmission range selector lever for proper operation.
- Check transmission control switch for proper operation. Instrument cluster indicator should indicate switch function.

**Ignition / Shifter Interlock Cable****Removal**

- Remove console. Refer to Section 01-12.
- Remove LH lower instrument panel trim and lower steering column shroud (3530).
- Remove interlock cable retaining screw and clip, disconnect ignition / shifter interlock cable (3F719) from lever cam.
- Remove steering column retaining nuts and lower steering column to floor. Disconnect electrical connector at interlock solenoid.
- Remove ignition / shifter interlock cable retaining screws from steering column.
- Guide ignition / shifter interlock cable out from under floor carpet (13000).

**Installation**

- Follow removal procedure in reverse order.
- Tighten steering column retaining nuts to 20-33 N·m (15-24 lb-ft). Tighten the ignition / shifter interlock cable retaining screws at the steering column to 2 N·m (18 lb-in), and at transmission range selector lever to 3-4 N·m (27-35 lb-in).
- Test for proper operation. The ignition key should only be removable with the transmission range selector lever in PARK. The transmission range selector lever should be locked in PARK with the key removed. The transmission range selector lever should be locked in the PARK position with the ignition switch in the RUN position and should release when the brake pedal (2455) is applied.

**REMOVAL AND INSTALLATION (Continued)**

**Transmission Shift Cable and Bracket**

**Removal**

1. Remove console finish panel (04567). Refer to Section 01-12.
2. Remove screws retaining transmission control selector dial bezel (7D443) to transmission range selector lever and housing.
3. Remove screws retaining transmission range selector lever and housing to floorpan.
4. Remove transmission shift cable and bracket-to-transmission range selector lever and housing retaining bolts. Disconnect cable from transmission range selector lever.
5. Raise vehicle on hoist.

6. Disconnect shift cable and bracket (7E395) from transmission control selector connecting rod adjustment stud (7B415).
7. Remove retaining nut from shift cable and bracket to bracket at transmission.

**Installation**

1. Follow removal procedure in reverse order.
2. Tighten shift cable and bracket nut to 13-25 N-m (10-18 lb-ft). Tighten shifter-to-floor pan bolts to 6-8 N-m (54-71 lb-in). Adjust transmission shift cable as described and tighten range selector lever-to-cable stud retaining nut to 17-23 N-m (13-16 lb-ft).

**Transmission Shift Cable and Bracket**

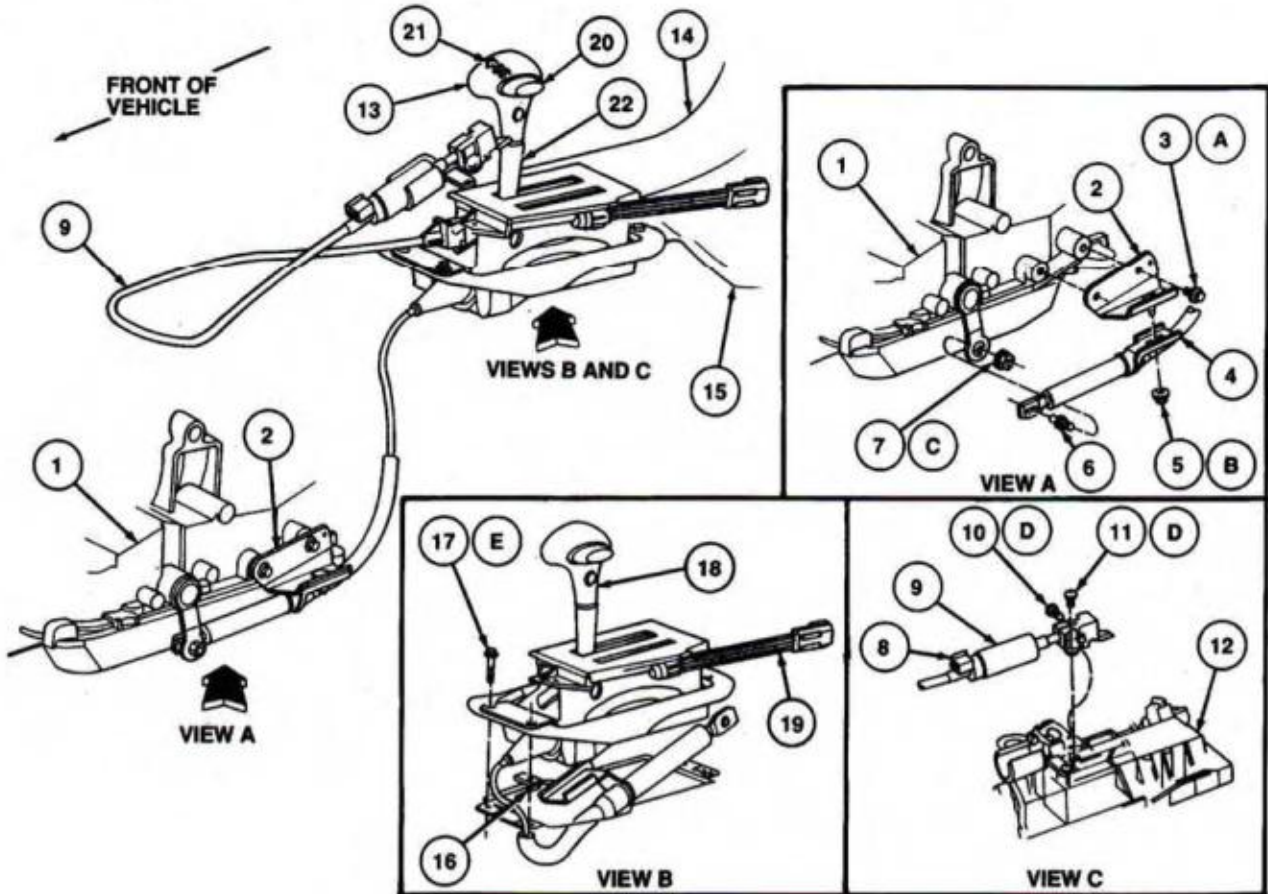

AD0296-A

Item	Part Number	Description
1	7000	Transmission Assy
2	7B229	Transmission Shift Cable Bracket
3	N605785-S56	Bolt (2 Req'd)
4	7E395	Shift Cable and Bracket
5	N806423-S56	Nut

(Continued)

Item	Part Number	Description
6	7B415	Transmission Control Selector Connecting Rod Adjustment Stud
7	N801555-S56	Nut
8	—	Interlock Wire Harness Connector (Part of 3F719)

(Continued)

**REMOVAL AND INSTALLATION (Continued)**

Item	Part Number	Description
9	3F719	Ignition / Shifter Interlock Cable
10	N808124-S8M	Screw
11	N806038-S2	Screw
12	3514	Steering Column Tube
13	7213	Selector Knob
14	045A36	Console Panel Assy
15	A11135	Front Floorpan
16	N623342-S56	U Nut (4 Req'd)
17	N605893-S56	Screw (4 Req'd)
18	7G550	Transmission Control Switch
19	15A808	Wire Assy-Transmission Range Indicator Lamp Bulb
20	7C489	Transmission Range Selector Lever Button

(Continued)

Item	Part Number	Description
21	7C307	Transmission Range Selector Lever Spring
22	—	Transmission Range Selector Lever Shroud (Part of 7213)
A	—	Tighten to 24-31 N-m (18-22 Lb-Ft)
B	—	Tighten to 13-25 N-m (10-18 Lb-Ft)
C	—	Tighten to 17-23 N-m (13-16 Lb-Ft)
D	—	Tighten to 2 N-m (18 Lb-In)
E	—	Tighten to 6-8 N-m (54-71 Lb-In)

**Transmission Range (TR) Sensor**

Refer to Section 07-01.

**Transmission Range Indicator Lamp Bulb, Floor Shift****Removal**

1. Remove transmission control selector dial bezel (7D443) as described.
2. Remove bulb assembly from bezel.
3. Remove indicator bulb.

**Installation**

1. Install indicator bulb onto lamp assembly.
2. Connect bulb assembly to transmission control selector dial bezel.
3. Install transmission control selector dial bezel as described.

5. Shift transmission range selector lever to REVERSE.
6. Verify that ignition switch cannot be turned to the LOCK position.
7. Move transmission range selector lever to PARK.
8. Verify that ignition switch can be turned to the LOCK position.
9. If the brake shift lock system is not operating as specified, refer to Diagnosis and Testing.

**Transmission Range Selector Lever**

**NOTE:** The ignition switch must be in RUN and brake pedal (2455) applied, or transmission range selector lever cannot be moved from PARK.

1. Make sure there is a click at each range when moved from PARK to LOW.
2. Check that transmission range selector lever release button returns smoothly after being pushed in.

**CLEANING AND INSPECTION****Brake / Shift Interlock System**

1. Turn the ignition switch to RUN.
2. Verify that transmission range selector lever is in PARK.
3. Without brake pedal (2455) applied, verify that transmission range selector lever cannot be moved from PARK.
4. Apply brake pedal. Verify that transmission range selector lever can be moved from PARK.

**ADJUSTMENTS****Transmission Shift Control Cable and Bracket**

**NOTE:** Transmission range selector lever linkage adjustments should be performed in the order in which they appear.

1. Position the transmission range selector lever in DRIVE position.
2. Raise vehicle on hoist.

**ADJUSTMENTS (Continued)**

3. Loosen the transmission shift cable and bracket to cable bracket retaining nut.
4. Move the transmission manual control lever (7A256) to the DRIVE position third detent position from the full clockwise position.
5. With the transmission range selector lever and manual control lever in the DRIVE position, tighten the retaining nut to 13-25 N·m (10-18 lb-ft).
6. Check the operation of the transmission in each transmission range.

**TORQUE SPECIFICATIONS (Cont'd)**

Description	N-m	Lb-Ft	Lb-In
Steering Column Retaining Nuts	20-33	15-24	—
Ignition / Shifter Interlock Cable To Shifter Assy Screw	3-4	—	27-35
Shift Cable and Bracket Nut	13-25	10-18	—
Transmission Shift Cable Bracket Bolt	24-31	18-22	—
Ignition / Shifter Interlock Cable To Column Retaining Screws	2	—	18

**SPECIFICATIONS****TORQUE SPECIFICATIONS**

Description	N-m	Lb-Ft	Lb-In
Range Selector Lever To Cable Stud Retaining Nut	17-23	13-16	—
Shifter-to-Floorpan Bolts	6-8	—	54-70

(Continued)

**SPECIAL SERVICE TOOLS/EQUIPMENT****ROTUNDA EQUIPMENT**

Model	Description
105-R0051	73 Digital Multimeter