

## 20.8 RF Connectors and Transmission Lines

There are many different types of transmission lines and RF connectors for coaxial cable, but the three most common for amateur use are the UHF, Type N and BNC families. The type of connector used for a specific job depends on the size of the cable, the frequency of operation and the power levels involved. **Table 20.12** shows the characteristics of many popular transmission lines, while **Table 20.13** details coax connectors.

### 20.8.1 UHF Connectors

The so-called UHF connector (the series name is not related to frequency) is found on most HF and some VHF equipment. It is the only connector many hams will ever see on coaxial cable. PL-259 is another name for the UHF male, and the female is also known as the SO-239. These connectors are rated for full legal amateur power at HF. They are poor for UHF work because they do not present a constant impedance, so the UHF label is a misnomer. PL-259 connectors are designed to fit RG-8 and RG-11 size cable (0.405-inch OD). Adapters are available for use with smaller RG-58, RG-59 and RG-8X size cable. UHF connectors are not weatherproof. Most PL-259s are nickel plated, but silver-plated connectors are much easier to solder and only slightly more expensive.

**Figure 20.40** shows how to install the solder type of PL-259 on RG-8 cable. Proper preparation of the cable end is the key to success. Follow these simple steps. Measure back about  $\frac{3}{4}$ -inch from the cable end and slightly

score the outer jacket around its circumference. With a sharp knife, cut through the outer jacket, through the braid and through the dielectric — almost to the center conductor. Be careful not to score the center conductor. Cutting through all outer layers at once keeps the braid from separating. (Using a coax stripping tool with preset blade depth makes this and subsequent trimming steps much easier.)

Pull the severed outer jacket, braid and dielectric off the end of the cable as one piece. Inspect the area around the cut, looking for any strands of braid hanging loose and snip them off. There won't be any if your knife was sharp enough. Next, score the outer jacket about  $\frac{5}{16}$ -inch back from the first cut. Cut through the jacket lightly; do not score the braid. This step takes practice. If you score the braid, start again. Remove the outer jacket.

Tin the exposed braid and center conductor, but apply the solder sparingly and avoid melting the dielectric. Slide the coupling ring onto the cable. Screw the connector body onto the cable. If you prepared the cable to the right dimensions, the center conductor will protrude through the center pin, the braid will show through the solder holes, and the body will actually thread onto the outer cable jacket. A very small amount of lubricant on the cable jacket will help the threading process.

Solder the braid through the solder holes. Solder through all four holes; poor connection to the braid is the most common form of PL-259 failure. A good connection between connector and braid is just as important as that between the center conductor and connector.

Use a large soldering iron for this job. With practice, you'll learn how much heat to use. If you use too little heat, the solder will bead up, not really flowing onto the connector body. If you use too much heat, the dielectric will melt, letting the braid and center conductor touch. After soldering, to prevent distorting the dielectric do not move the connector or cable until both are cool. A damp rag or sponge can be used to cool the connector quickly.

Solder the center conductor to the center pin. The solder should flow on the inside, not the outside, of the center pin. If you wait until the connector body cools off from soldering the braid, you'll have less trouble with the dielectric melting. Trim the center conductor to be even with the end of the center pin. Use a small file to round the end, removing any solder that built up on the outer surface of the center pin. Use a sharp knife, very fine sandpaper or steel wool to remove any solder flux from the outer surface of the center pin. Screw the coupling ring onto the body, and you're finished.

**Figure 20.41** shows how to install a PL-259 connector on RG-58 or RG-59 cable. An adapter is used for the smaller cable with standard RG-8 size PL-259s. (UG-175 for RG-58 and UG-176 for RG-59.) Prepare the cable as shown. Once the braid is prepared, screw the adapter into the PL-259 shell and finish the job as you would a PL-259 on RG-8 cable.

**Figure 20.42** shows the instructions and dimensions for crimp-on UHF connectors that fit all common sizes of coaxial cable.

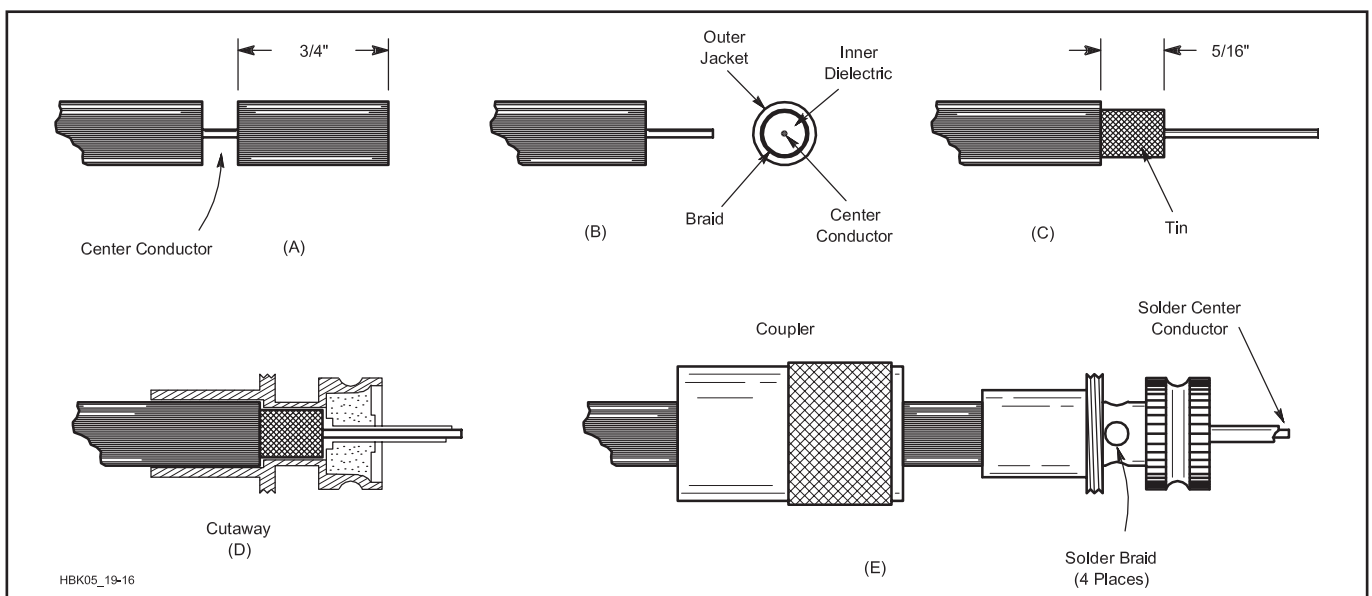

**Figure 20.40** — The PL-259, or UHF, connector is almost universal for amateur HF work and is popular for equipment operating in the VHF range. Steps A through E are described in detail in the text.

While amateurs have been reluctant to adopt crimp-on connectors, the availability of good quality connectors and inexpensive crimping tools make crimp technology a good choice, even for connectors used outside. Soldering the center conductor to the connector tip is optional.

UHF connectors are not waterproof and must be waterproofed whether soldered or crimped as shown in the section of the Safety chapter on Antenna and Tower Safety.

### 20.8.2 BNC, N, and F Connectors

The BNC connectors illustrated in **Figure 20.43** are popular for low power levels at VHF and UHF. They accept RG-58 and RG-59 cable, and are available for cable mounting in both male and female versions. Several different styles are available, so be sure to use the dimensions for the type you have. Follow the installation instructions carefully. If you prepare the cable to the wrong dimensions, the center pin will not seat properly with connectors of the opposite gender. Sharp scissors are a big help for trimming the braid evenly. Crimp-on BNC connectors are also available, with a large number of variations, including a twist-on version. A guide to installing these connectors is available with the downloadable supplemental content.

The Type N connector, illustrated in **Figure 20.44**, is a must for high-power VHF and UHF operation. N connectors are available in male and female versions for cable mounting and are designed for RG-8 size cable. Unlike UHF connectors, they are designed to maintain a constant impedance at cable joints. Like BNC connectors, it is important to prepare the cable to the right dimensions. The center pin must be positioned correctly to mate with the center pin of connectors of the opposite gender. Use the right dimensions for the connector style you have. Crimp-on N connectors are also available, again with a large number of

variations. A guide to installing these connectors is available with the downloadable supplemental content.

Type F connectors, used primarily on cable TV connections, are also popular for receive-only antennas and can be used with RG-59 or the increasingly popular RG-6 cable available at low cost. Crimp-on connectors are the only option for these connectors and **Figure 20.45** shows a general guide for installing them. The exact dimensions vary between connector styles and manufacturers — information on crimping is generally provided with the connectors. There are two styles of crimp; ferrule and compression. The ferrule crimp method is similar to that for UHF, BNC, and N connectors in which a metal ring is compressed around the exposed coax shield. The compression crimp forces a bushing into the back of the connector, clamping the shield against the connector body. In all cases, the exposed center conductor of the cable — a solid wire — must end flush with the end of the connector. A center conductor that is too short may not make a good connection.

### 20.8.3 Connector Identifier and Range Chart

The following pages of figures provide dimensions and side views to help identify the different types of connectors used for RF through microwave frequencies. Dimensions are provided in both imperial and metric units as appropriate. For mm-wave and microwave connectors, calipers or a micrometer may be required to provide an accurate measurement capable of distinguishing between similar connectors. These specifications are intended for connector identification only and should not be the sole dimensions used when laying out a circuit board or drilling a mounting hole.

These figures and chart were provided by Pasternack ([www.pasternack.com](http://www.pasternack.com)), a major distributor of coaxial connectors, cable, tools, and other RF materials and supplies.

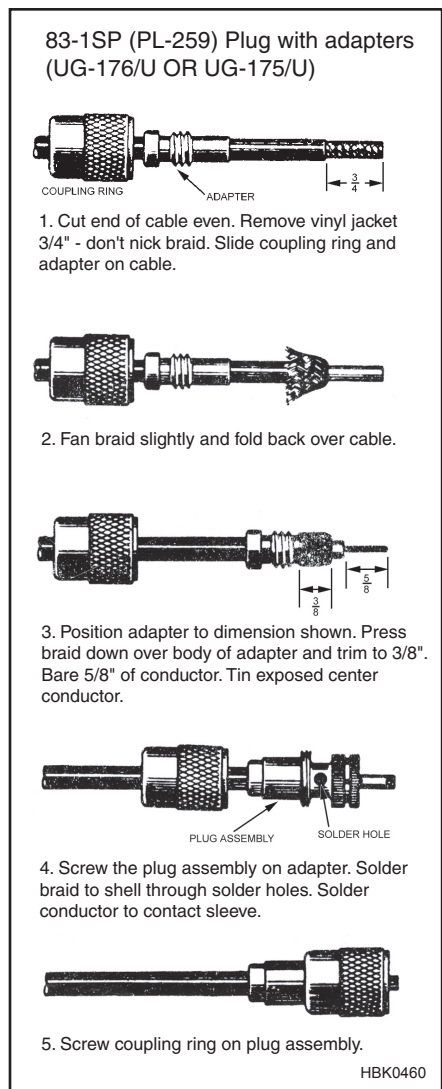

**Figure 20.41 — Installing PL-259 plugs on RG-58 or RG-59 cable requires the use of UG-175 or UG-176 adapters, respectively. The adapter screws into the plug body using the threads of the connector that grip the jacket on larger cables. (Courtesy Amphenol Electronic Components)**

**Table 22.12**

**Nominal Characteristics of Commonly Used Transmission Lines**

RG or Type	Part Number	Nom. $Z_0$ $\Omega$	VF %	Cap. pF/ft	Cent. Cond. AWG	Diel. Type	Shield Type	Jacket Matl	OD inches	Max V (RMS)	Matched Loss (dB/100')			
											1 MHz	10	100	1000
RG-6	Belden 1694A	75	82	16.2	#18 Solid BC	FPE	FC	P1	0.275	300	0.3	.7	1.8	5.9
RG-6	Belden 8215	75	66	20.5	#21 Solid CCS	PE	D	PE	0.332	2700	0.4	0.8	2.7	9.8
RG-8	Belden 7810A	50	86	23.0	#10 Solid BC	FPE	FC	PE	0.405	300	0.1	0.4	1.2	4.0
RG-8	TMS LMR400	50	85	23.9	#10 Solid CCA	FPE	FC	PE	0.405	600	0.1	0.4	1.3	4.1
RG-8	Belden 9913	50	84	24.6	#10 Solid BC	ASPE	FC	P1	0.405	300	0.1	0.4	1.3	4.5
RG-8	CXP1318FX	50	84	24.0	#10 Flex BC	FPE	FC	P2N	0.405	600	0.1	0.4	1.3	4.5
RG-8	Belden 9913F	50	83	24.6	#11 Flex BC	FPE	FC	P1	0.405	300	0.2	0.6	1.5	4.8
RG-8	Belden 9914	50	82	24.8	#10 Solid BC	FPE	FC	P1	0.405	300	0.2	0.5	1.5	4.8
RG-8	TMS LMR400UF	50	85	23.9	#10 Flex BC	FPE	FC	PE	0.405	600	0.1	0.4	1.4	4.9
RG-8	DRF-BF	50	84	24.5	#9.5 Flex BC	FPE	FC	PE	0.405	600	0.1	0.5	1.6	5.2
RG-8	WM CQ106	50	84	24.5	#9.5 Flex BC	FPE	FC	P2N	0.405	600	0.2	0.6	1.8	5.3
RG-8	CXP008	50	78	26.0	#13 Flex BC	FPE	S	P1	0.405	600	0.1	0.5	1.8	7.1
RG-8	Belden 8237	52	66	29.5	#13 Flex BC	PE	S	P1	0.405	3700	0.2	0.6	1.9	7.4
RG-8X	Belden 7808A	50	86	23.5	#15 Solid BC	FPE	FC	PE	0.240	300	0.2	0.7	2.3	7.4
RG-8X	TMS LMR240	50	84	24.2	#15 Solid BC	FPE	FC	PE	0.242	300	0.2	0.8	2.5	8.0
RG-8X	WM CQ118	50	82	25.0	#16 Flex BC	FPE	FC	P2N	0.242	300	0.3	0.9	2.8	8.4
RG-8X	TMS LMR240UF	50	84	24.2	#15 Flex BC	FPE	FC	PE	0.242	300	0.2	0.8	2.8	9.6
RG-8X	Belden 9258	50	82	24.8	#16 Flex BC	FPE	S	P1	0.242	300	0.3	0.9	3.2	11.2
RG-8X	CXP08XB	50	80	25.3	#16 Flex BC	FPE	S	P1	0.242	300	0.3	1.0	3.1	14.0
RG-9	Belden 8242	51	66	30.0	#13 Flex SPC	PE	SCBC	P2N	0.420	5000	0.2	0.6	2.1	8.2
RG-11	Belden 8213	75	84	16.1	#14 Solid BC	FPE	S	PE	0.405	300	0.1	0.4	1.3	5.2
RG-11	Belden 8238	75	66	20.5	#18 Flex TC	PE	S	P1	0.405	300	0.2	0.7	2.0	7.1
RG-58	Belden 7807A	50	85	23.7	#18 Solid BC	FPE	FC	PE	0.195	300	0.3	1.0	3.0	9.7
RG-58	TMS LMR200	50	83	24.5	#17 Solid BC	FPE	FC	PE	0.195	300	0.3	1.0	3.2	10.5
RG-58	WM CQ124	52	66	28.5	#20 Solid BC	PE	S	PE	0.195	1400	0.4	1.3	4.3	14.3
RG-58	Belden 8240	52	66	29.9	#20 Solid BC	PE	S	P1	0.193	1400	0.3	1.1	3.8	14.5
RG-58A	Belden 8219	53	73	26.5	#20 Flex TC	FPE	S	P1	0.195	300	0.4	1.3	4.5	18.1
RG-58C	Belden 8262	50	66	30.8	#20 Flex TC	PE	S	P2N	0.195	1400	0.4	1.4	4.9	21.5
RG-58A	Belden 8259	50	66	30.8	#20 Flex TC	PE	S	P1	0.192	1400	0.5	1.5	5.4	22.8
RG-59	Belden 1426A	75	83	16.3	#20 Solid BC	FPE	S	P1	0.242	300	0.3	0.9	2.6	8.5
RG-59	CXP 0815	75	82	16.2	#20 Solid BC	FPE	S	P1	0.232	300	0.5	0.9	2.2	9.1
RG-59	Belden 8212	75	78	17.3	#20 Solid CCS	FPE	S	P1	0.242	300	0.2	1.0	3.0	10.9
RG-59	Belden 8241	75	66	20.4	#23 Solid CCS	PE	S	P1	0.242	1700	0.6	1.1	3.4	12.0
RG-62A	Belden 9269	93	84	13.5	#22 Solid CCS	ASPE	S	P1	0.240	750	0.3	0.9	2.7	8.7
RG-62B	Belden 8255	93	84	13.5	#24 Flex CCS	ASPE	S	P2N	0.242	750	0.3	0.9	2.9	11.0
RG-63B	Belden 9857	125	84	9.7	#22 Solid CCS	ASPE	S	P2N	0.405	750	0.2	0.5	1.5	5.8
RG-83	WM165	35	66	44.0	#10 Solid BC	PE	S	P2	0.405	2000	0.23	0.8	2.8	9.6
RG-142	CXP 183242	50	69.5	29.4	#19 Solid SCCS	TFE	D	FEP	0.195	1900	0.3	1.1	3.8	12.8
RG-142B	Belden 83242	50	69.5	29.0	#19 Solid SCCS	TFE	D	TFE	0.195	1400	0.3	1.1	3.9	13.5
RG-174	Belden 7805R	50	73.5	26.2	#25 Solid BC	FPE	FC	P1	0.110	300	0.6	2.0	6.5	21.3
RG-174	Belden 8216	50	66	30.8	#26 Flex CCS	PE	S	P1	0.110	1100	0.8	2.5	8.6	33.7
RG-213	Belden 8267	50	66	30.8	#13 Flex BC	PE	S	P2N	0.405	3700	0.2	0.6	2.1	8.0
RG-213	CXP213	50	66	30.8	#13 Flex BC	PE	S	P2N	0.405	600	0.2	0.6	2.0	8.2
RG-214	Belden 8268	50	66	30.8	#13 Flex SPC	PE	D	P2N	0.425	3700	0.2	0.7	2.2	8.0
RG-216	Belden 9850	75	66	20.5	#18 Flex TC	PE	D	P2N	0.425	3700	0.2	0.7	2.0	7.1
RG-217	WM CQ217F	50	66	30.8	#10 Flex BC	PE	D	PE	0.545	7000	0.1	0.4	1.4	5.2
RG-217	M17778-RG217	50	66	30.8	#10 Solid BC	PE	D	P2N	0.545	7000	0.1	0.4	1.4	5.2
RG-218	M17779-RG218	50	66	29.5	#4.5 Solid BC	PE	S	P2N	0.870	11000	0.1	0.2	0.8	3.4
RG-223	Belden 9273	50	66	30.8	#19 Solid SPC	PE	D	P2N	0.212	1400	0.4	1.2	4.1	14.5
RG-303	Belden 84303	50	69.5	29.0	#18 Solid SCCS	TFE	S	TFE	0.170	1400	0.3	1.1	3.9	13.5
RG-316	CXP TJ1316	50	69.5	29.4	#26 Flex BC	TFE	S	FEP	0.098	1200	1.2	2.7	8.0	26.1
RG-316	Belden 84316	50	69.5	29.0	#26 Flex SCCS	TFE	S	FEP	0.096	900	0.8	2.5	8.3	26.0
RG-393	M17127-RG393	50	69.5	29.4	#12 Flex SPC	TFE	D	FEP	0.390	5000	0.2	0.5	1.7	6.1
RG-400	M17128-RG400	50	69.5	29.4	#20 Flex SPC	TFE	D	FEP	0.195	1400	0.4	1.3	4.3	15.0
LMR500	TMS LMR500UF	50	85	23.9	#7 Flex BC	FPE	FC	PE	0.500	2500	0.1	0.4	1.2	4.0
LMR500	TMS LMR500	50	85	23.9	#7 Solid CCA	FPE	FC	PE	0.500	2500	0.1	0.3	0.9	3.3
LMR600	TMS LMR600	50	86	23.4	#5.5 Solid CCA	FPE	FC	PE	0.590	4000	0.1	0.2	0.8	2.7
LMR600	TMS LMR600UF	50	86	23.4	#5.5 Flex BC	FPE	FC	PE	0.590	4000	0.1	0.2	0.8	2.7
LMR1200	TMS LMR1200	50	88	23.1	#0 Copper Tube	FPE	FC	PE	1.200	4500	0.04	0.1	0.4	1.3
<b>Hardline</b>														
1/2"	CATV Hardline	50	81	25.0	#5.5 BC	FPE	SM	none	0.500	2500	0.05	0.2	0.8	3.2
1/2"	CATV Hardline	75	81	16.7	#11.5 BC	FPE	SM	none	0.500	2500	0.1	0.2	0.8	3.2
7/8"	CATV Hardline	50	81	25.0	#1 BC	FPE	SM	none	0.875	4000	0.03	0.1	0.6	2.9
7/8"	CATV Hardline	75	81	16.7	#5.5 BC	FPE	SM	none	0.875	4000	0.03	0.1	0.6	2.9
LDF4-50A	Helix - 1/2"	50	88	25.9	#5 Solid BC	FPE	CC	PE	0.630	1400	0.02	0.2	0.6	2.4
LDF5-50A	Helix - 7/8"	50	88	25.9	0.355" BC	FPE	CC	PE	1.090	2100	0.03	0.10	0.4	1.3
LDF6-50A	Helix - 1 1/4"	50	88	25.9	0.516" BC	FPE	CC	PE	1.550	3200	0.02	0.08	0.3	1.1
<b>Parallel Lines</b>														
TV Twinlead (Belden 9085)		300	80	4.5	#22 Flex CCS	PE	none	P1	0.400	**	0.1	0.3	1.4	5.9
Twinlead (Belden 8225)		300	80	4.4	#20 Flex BC	PE	none	P1	0.400	8000	0.1	0.2	1.1	4.8
Generic Window Line		450	91	2.5	#18 Solid CCS	PE	none	P1	1.000	10000	0.02	0.08	0.3	1.1
WM CQ 554		440	91	2.7	#14 Flex CCS	PE	none	P1	1.000	10000	0.04	0.01	0.6	3.0
WM CQ 552		440	91	2.5	#16 Flex CCS	PE	none	P1	1.000	10000	0.05	0.2	0.6	2.6
WM CQ 553		450	91	2.5	#18 Flex CCS	PE	none	P1	1.000	10000	0.06	0.2	0.7	2.9
WM CQ 551		450	91	2.5	#18 Solid CCS	PE	none	P1	1.000	10000	0.05	0.02	0.6	2.8
Open-Wire Line		600	0.95-99***	1.7	#12 BC	none	none	none	**	12000	0.02	0.06	0.2	—

(continues on next page)

(continued from page 3)

**Approximate Power Handling Capability (1:1 SWR, 40°C Ambient):**

	1.8 MHz	7	14	30	50	150	220	450	1 GHz
RG-58 Style	1350	700	500	350	250	150	120	100	50
RG-59 Style	2300	1100	800	550	400	250	200	130	90
RG-8X Style	1830	840	560	360	270	145	115	80	50
RG-8/213 Style	5900	3000	2000	1500	1000	600	500	350	250
RG-217 Style	20000	9200	6100	3900	2900	1500	1200	800	500
LDF4-50A	38000	18000	13000	8200	6200	3400	2800	1900	1200
LDF5-50A	67000	32000	22000	14000	11000	5900	4800	3200	2100
LMR500	18000	9200	6500	4400	3400	1900	1600	1100	700
LMR1200	52000	26000	19000	13000	10000	5500	4500	3000	2000

**Legend:**

- \*\* Not Available or varies
- \*\*\* Varies with spacer material and spacing
- ASPE Air Spaced Polyethylene
- BC Bare Copper
- CC Corrugated Copper
- CCA Copper Cover Aluminum
- CCS Copper Covered Steel
- CXP Cable X-Perts, Inc.
- D Double Copper Braids
- DRF Davis RF
- FC Foil + Tinned Copper Braid
- FEP Teflon® Type IX
- Flex Flexible Stranded Wire
- FPE Foamed Polyethylene
- Heliax Andrew Corp Heliax

**UHF Connectors**

**Braid Crimp - Solder Center Contact**

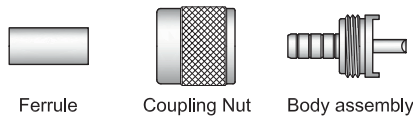

Amphenol	Cable RG-U	Cable Attachment		Hex Crimp Data			Stripping Dims, inches (mm)		
		Outer	Inner	Cavity for Outer Ferrule	Die Set Tool 227-994	CTL Series Tool No.	a	b	c
83-58SP	58, 141	Crimp	Solder	0.213(5.4)	227-1221-11	CTL-1	1.14 (29.0)	0.780 (19.9)	0.250 (6.4)
83-58SP-1002	400	Crimp	Solder	0.213(5.4)	227-1221-11	CTL-1	1.14 (29.0)	0.780 (19.9)	0.250 (6.4)
83-59DCP-RFX	59	Crimp	Solder	0.255(6.5)	227-1221-13	CTL-1	1.22 (30.9)	0.890* (22.6)	0.543 (13.8)
83-58SCP-RFX	58	Crimp	Solder	0.213(5.4)	227-1221-11	CTL-1	1.22 (30.9)	0.890* (22.6)	0.543 (13.8)
83-59SP	59	Crimp	Solder	0.255(6.5)	227-1221-13	CTL-1	1.22 (30.9)	0.890* (22.6)	0.543 (13.8)
83-8SP-RFX	8	Crimp	Solder	0.429(10.9)	227-1221-25	CTL-3	1.22 (30.9)	0.890* (22.6)	0.543 (13.8)

See [www.AmphenolRF.com](http://www.AmphenolRF.com) for assembly instructions for all other connector types. These dimensions only apply to Amphenol connectors and may not be correct for other manufacturers.  
 \* Manufacturer's assembly dimensions incorrectly show 0.574 inches.



**Step 1** Cut end of cable even. Strip cable to dimensions shown in table. All cuts are to be sharp and square. Do not nick braid, dielectric or center conductor. Tin center conductor avoiding excessive heat.

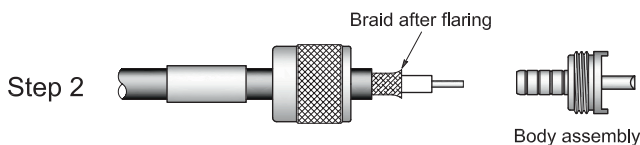

**Step 2** Slide coupling nut and ferrule over cable jacket. Flair braid slightly as shown. Install cable into body assembly, so inner ferrule portion slides under braid, until braid butts shoulder. Slide outer ferrule over braid until it butts shoulder. Crimp ferrule with tool and die set indicated in table.

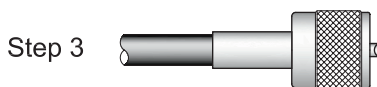

**Step 3** Soft solder center conductor to contact. Avoid heating contact excessively to prevent damaging insulator. Slide/screw coupling nut over body.

HBK0475

**Figure 20.42 — Crimp-on UHF connectors are available for all sizes of popular coaxial cable and save considerable time over soldered connectors. The performance and reliability of these connectors is equivalent to soldered connectors, if crimped properly. (Courtesy Amphenol Electronic Components)**

## BNC CONNECTORS

### Standard Clamp

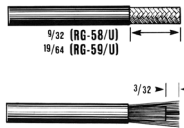

1. Cut cable even. Strip jacket. Fray braid and strip dielectric. **Don't nick braid or center conductor.** Tin center conductor.

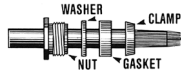

2. Taper braid. Slide nut, washer, gasket and clamp over braid. Clamp inner shoulder should fit squarely against end of jacket.

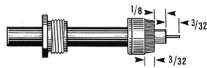

3. With clamp in place, comb out braid, fold back smooth as shown. Trim center conductor.



4. Solder contact on conductor through solder hole. Contact should butt against dielectric. Remove excess solder from outside of contact. Avoid excess heat to prevent swollen dielectric which would interfere with connector body.

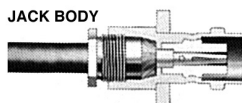
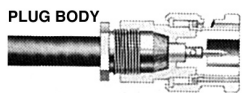

5. Push assembly into body. Screw nut into body with wrench until tight. **Don't rotate body on cable to tighten.**

### Improved Clamp

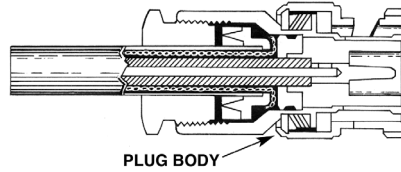
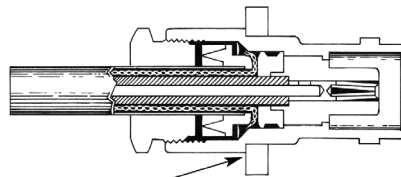
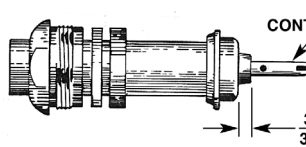
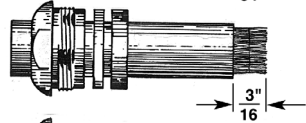
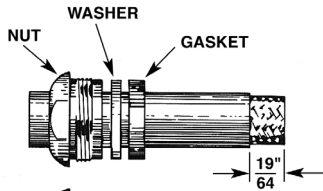

Follow 1, 2, 3 and 4 in BNC connectors (standard clamp) except as noted. Strip cable as shown. Slide gasket on cable with groove facing clamp. Slide clamp with sharp edge facing gasket. Clamp should cut gasket to seal properly.

HBK05\_19-18

### C. C. Clamp

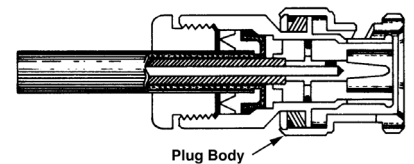
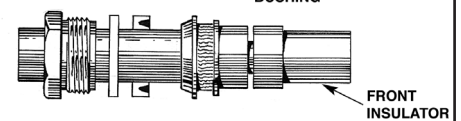
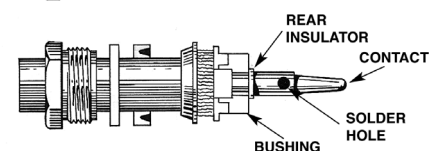
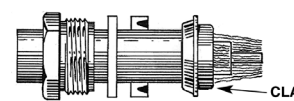
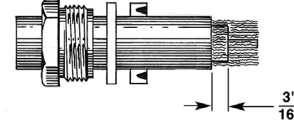
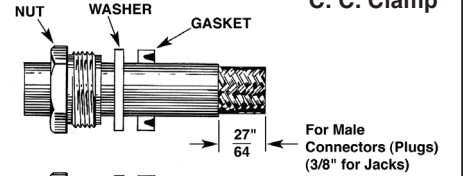

1. Follow steps 1, 2, and 3 as outlined for the standard-clamp BNC connector.

2. Slide on bushing, rear insulator and contact. The parts must butt securely against each other, as shown.

3. Solder the center conductor to the contact. Remove flux and excess solder.

4. Slide the front insulator over the contact, making sure it butts against the contact shoulder.

5. Insert the prepared cable end into the connector body and tighten the nut. Make sure the sharp edge of the clamp seats properly in the gasket.

Figure 20.43 — BNC connectors are common on VHF and UHF equipment at low power levels. (Courtesy Amphenol Electronic Components)

**Table 22.13**

**Coaxial Cable Connectors**

**UHF Connectors**

Military No.	Style	Cable RG- or Description
PL-259	Str (m)	8, 9, 11, 13, 63, 87, 149, 213, 214, 216, 225
UG-111	Str (m)	59, 62, 71, 140, 210
SO-239	Pnl (f)	Std, mica/phenolic insulation
UG-266	Blkhd (f)	Rear mount, pressurized, copolymer of styrene ins.

**Adapters**

PL-258	Str (f/f)	Polystyrene ins.
UG-224,363	Blkhd (f/f)	Polystyrene ins.
UG-646	Ang (f/m)	Polystyrene ins.
M-359A	Ang (m/f)	Polystyrene ins.
M-358	T (f/m/f)	Polystyrene ins.

**Reducers**

UG-175	55, 58, 141, 142 (except 55A)
UG-176	59, 62, 71, 140, 210

**Family Characteristics:**

All are nonweatherproof and have a nonconstant impedance. Frequency range: 0-500 MHz. Maximum voltage rating: 500 V (peak).

**N Connectors**

Military No.	Style	Cable RG-	Notes
UG-21	Str (m)	8, 9, 213, 214	50 Ω
UG-94A	Str (m)	11, 13, 149, 216	70 Ω
UG-536	Str (m)	58, 141, 142	50 Ω
UG-603	Str (m)	59, 62, 71, 140, 210	50 Ω
UG-23, B-E	Str (f)	8, 9, 87, 213, 214, 225	50 Ω
UG-602	Str (f)	59, 62, 71, 140, 210	—
UG-228B, D, E	Pnl (f)	8, 9, 87, 213, 214, 225	—
UG-1052	Pnl (f)	58, 141, 142	50 Ω
UG-593	Pnl (f)	59, 62, 71, 140, 210	50 Ω
UG-160A, B, D	Blkhd (f)	8, 9, 87, 213, 214, 225	50 Ω
UG-556	Blkhd (f)	58, 141, 142	50 Ω
UG-58, A	Pnl (f)		50 Ω
UG-997A	Ang (f)		50 Ω

Panel mount (f) with clearance above panel

M39012/04-	Blkhd (f)	Front mount hermetically sealed
UG-680	Blkhd (f)	Front mount pressurized

**N Adapters**

Military No.	Style	Notes
UG-29,A,B	Str (f/f)	50 Ω, TFE ins.
UG-57A,B	Str (m/m)	50 Ω, TFE ins.
UG-27A,B	Ang (f/m)	Mitre body
UG-212A	Ang (f/m)	Mitre body
UG-107A	T (f/m/f)	—
UG-28A	T (f/f/f)	—
UG-107B	T (f/m/f)	—

**Family Characteristics:**

N connectors with gaskets are weatherproof. RF leakage: -90 dB min @ 3 GHz. Temperature limits: TFE: -67° to 390°F (-55° to 199°C). Insertion loss 0.15 dB max @ 10 GHz. Copolymer of styrene: -67° to 185°F (-55° to 85°C). Frequency range: 0-11 GHz. Maximum voltage rating: 1500 V P-P. Dielectric withstanding voltage 2500 V RMS. SWR (MIL-C-39012 cable connectors) 1.3 max 0-11 GHz.

**BNC Connectors**

Military No.	Style	Cable RG-	Notes
UG-88C	Str (m)	55, 58, 141, 142, 223, 400	
Military No.	Style	Cable RG-	Notes
UG-959	Str (m)	8, 9	
UG-260,A	Str (m)	59, 62, 71, 140, 210	Rexolite ins.
UG-262	Pnl (f)	59, 62, 71, 140, 210	Rexolite ins.
UG-262A	Pnl (f)	59, 62, 71, 140, 210	nwx, Rexolite ins.
UG-291	Pnl (f)	55, 58, 141, 142, 223, 400	
UG-291A	Pnl (f)	55, 58, 141, 142, 223, 400	nwx
UG-624	Blkhd (f)	59, 62, 71, 140, 210	Front mount Rexolite ins. Standard
UG-1094A	Blkhd		
UG-625B	Receptacle		
UG-625			

**BNC Adapters**

Military No.	Style	Notes
UG-491,A	Str (m/m)	
UG-491B	Str (m/m)	Beryllium, outer contact
UG-914	Str (f/f)	
UG-306	Ang (f/m)	
UG-306A,B	Ang (f/m)	Beryllium outer contact
UG-414,A	Pnl (f/f)	# 3-56 tapped flange holes
UG-306	Ang (f/m)	
UG-306A,B	Ang (f/m)	Beryllium outer contact
UG-274	T (f/m/f)	
UG-274A,B	T (f/m/f)	Beryllium outer contact

**Family Characteristics:**

Z = 50 Ω. Frequency range: 0-4 GHz w/low reflection; usable to 11 GHz. Voltage rating: 500 V P-P. Dielectric withstanding voltage 500 V RMS. SWR: 1.3 max 0-4 GHz. RF leakage -55 dB min @ 3 GHz. Insertion loss: 0.2 dB max @ 3 GHz. Temperature limits: TFE: -67° to 390°F (-55° to 199°C); Rexolite insulators: -67° to 185°F (-55° to 85°C). "Nwx" = not weatherproof.

**HN Connectors**

Military No.	Style	Cable RG-	Notes
UG-59A	Str (m)	8, 9, 213, 214	
UG-1214	Str (f)	8, 9, 87, 213, 214, 225	Captivated contact
UG-60A	Str (f)	8, 9, 213, 214	Copolymer of styrene ins.
UG-1215	Pnl (f)	8, 9, 87, 213, 214, 225	Captivated contact
UG-560	Pnl (f)		
UG-496	Pnl (f)		
UG-212C	Ang (f/m)		Beryllium outer contact

**Family Characteristics:**

Connector Styles: Str = straight; Pnl = panel; Ang = Angle; Blkhd = bulkhead. Z = 50 Ω. Frequency range = 0-4 GHz. Maximum voltage rating = 1500 V P-P. Dielectric withstanding voltage = 5000 V RMS. SWR = 1.3. All HN series are weatherproof. Temperature limits: TFE: -67° to 390°F (-55° to 199°C); copolymer of styrene: -67° to 185°F (-55° to 85°C).

**Cross-Family Adapters**

Families	Description	Military No.
HN to BNC	HN-m/BNC-f	UG-309
N to BNC	N-m/BNC-f	UG-201,A
	N-f/BNC-m	UG-349,A
	N-m/BNC-m	UG-1034
N to UHF	N-m/UHF-f	UG-146
	N-f/UHF-m	UG-83,B
	N-m/UHF-m	UG-318
UHF to BNC	UHF-m/BNC-f	UG-273
	UHF-f/BNC-m	UG-255

# Type N assembly instructions

HBK05\_19-19

## CLAMP TYPES

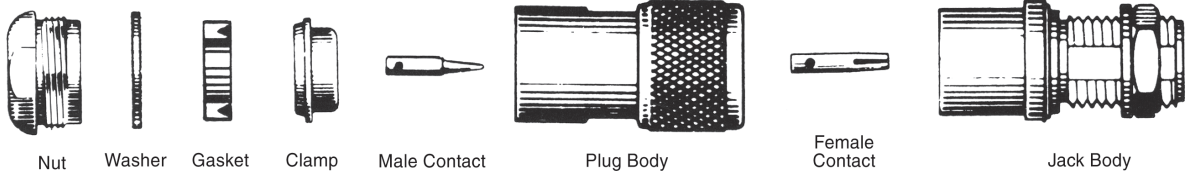

### Step 1

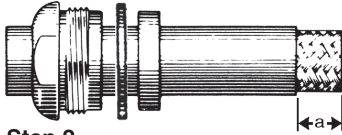

### Step 2

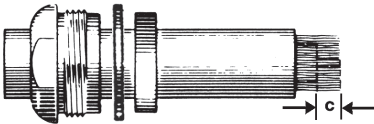

### Step 3

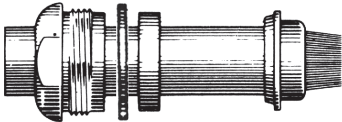

### Step 4

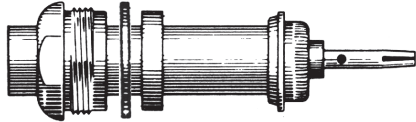

### Step 5

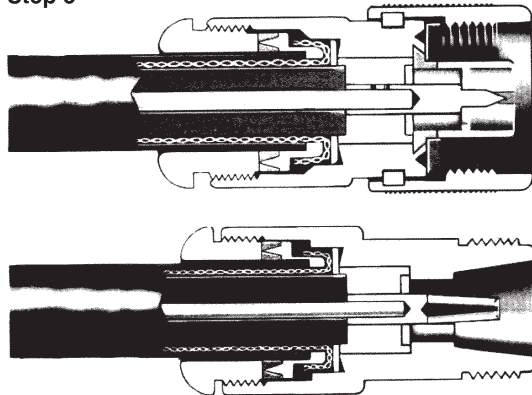

Amphenol Number	Connector Type	Cable RG-/U	Strip Dims., inches (mm)	
			a	c
82-61	N Plug	8, 9, 144, 165, 213, 214, 216, 225	0.359(9.1)	0.234(6.0)
82-62	N Panel Jack	8, 9, 87A, 144, 165, 213, 214, 216, 225	0.312(7.9)	0.187(4.7)
82-63	N Jack		0.281(7.1)	0.156(4.0)
82-67	N Bulkhead Jack			
82-202	N Plug	8, 9, 144, 165, 213, 214, 216, 225	0.359(9.1)	0.234(6.0)
82-202-RFX	N Plug	8, 213, 214	0.315(8.0)	0.177(4.5)
82-202-1006	N Plug	Beiden 9913	0.359(9.1)	0.234(6.0)
82-835	N Angle Plug	8, 9, 87A, 144, 165, 213, 214, 216, 225	0.281(7.1)	0.156(4.0)
18750	N Angle Plug	58, 141, 142	0.484(12.3)	0.234(5.9)
34025	N Plug		0.390(9.9)	0.203(5.2)
34525	N Plug	59, 62, 71, 140, 210	0.410(10.4)	0.230(5.8)
35025	N Jack	58, 141, 142	0.375(9.5)	0.187(4.7)
36500	N Jack	59, 62, 71, 140, 210	0.484(12.3)	0.200(5.1)

See [www.AmphenolRF.com](http://www.AmphenolRF.com) for assembly instructions for all other connector types. These dimensions only apply to Amphenol connectors and may not be correct for other manufacturers.

**Step 1** Place nut, washer, and gasket, with "V" groove toward clamp, over cable and cut off jacket to dimension a.

**Step 2** Comb out braid and fold out. Cut off cable dielectric to dim. c as shown.

**Step 3** Pull braid wires forward and taper toward center conductor. Place clamp over braid and push back against cable jacket.

**Step 4** Fold back braid wires as shown, trim braid to proper length and form over clamp as shown. Solder contact to center conductor.

**Step 5** Insert cable and parts into connector body. Make sure sharp edge of clamp seats properly in gasket. Tighten nut.

Figure 20.44 — Type N connectors are a must for high-power VHF and UHF operation. (Courtesy Amphenol Electronic Components)

### Crimp-style F-connector Installation

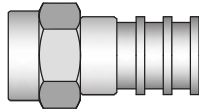

**Step 1** All parts of the connector are shown. A crimp tool is necessary to complete the connection.

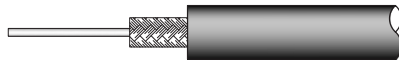

**Step 2** Strip the conductor, dielectric, braid and jacket as per "RECOMMENDED CABLE STRIPPING DIM'S" in catalog.

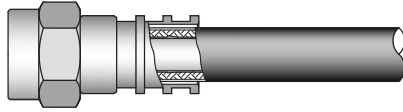

**Step 3** Insert cable into the back of the main body gently, and feed it into the guide hole.

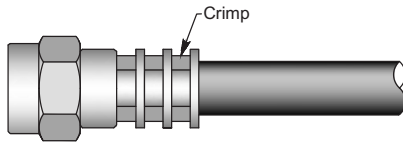

**Step 4** Crimp it with the crimp tool as shown.

### Compression-style F-connector Installation

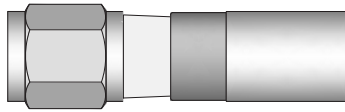

**Step 1:** The connector is a one-piece design. Use a stripping tool and compression tool to install the connector.

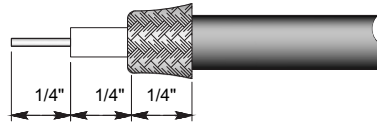

**Step 2:** Strip the conductor, dielectric, braid, and jacket. (Refer to manufacturer's recommendations.)

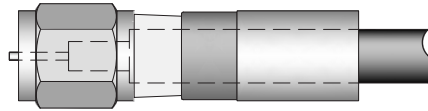

**Step 3:** Insert the cable into the connector until the dielectric is flush with the internal connector base and the center conductor extends just past the threaded end of the connector.

**Step 4:** Place connector in compression tool and seat firmly.

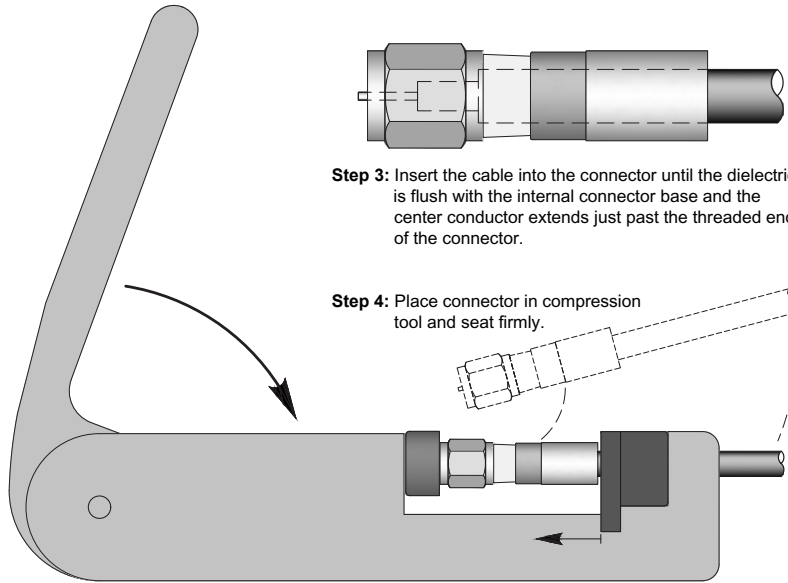

**Step 5** Compress the connector until compression housing is completely installed.

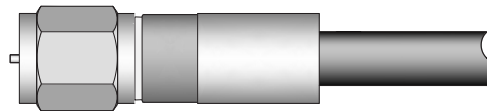

Hbk0871

Figure 20.45 — Type F connectors, commonly used for cable TV connections, can be used for receive-only antennas with inexpensive RG-59 and RG-6 cable. The older crimp-style connectors have largely been replaced by the more reliable and weather-resistant compression-style connectors. Follow the manufacturer's instruction for the cable and connector selected. [Courtesy Amphenol Electronic Components and Technetix, Inc.]

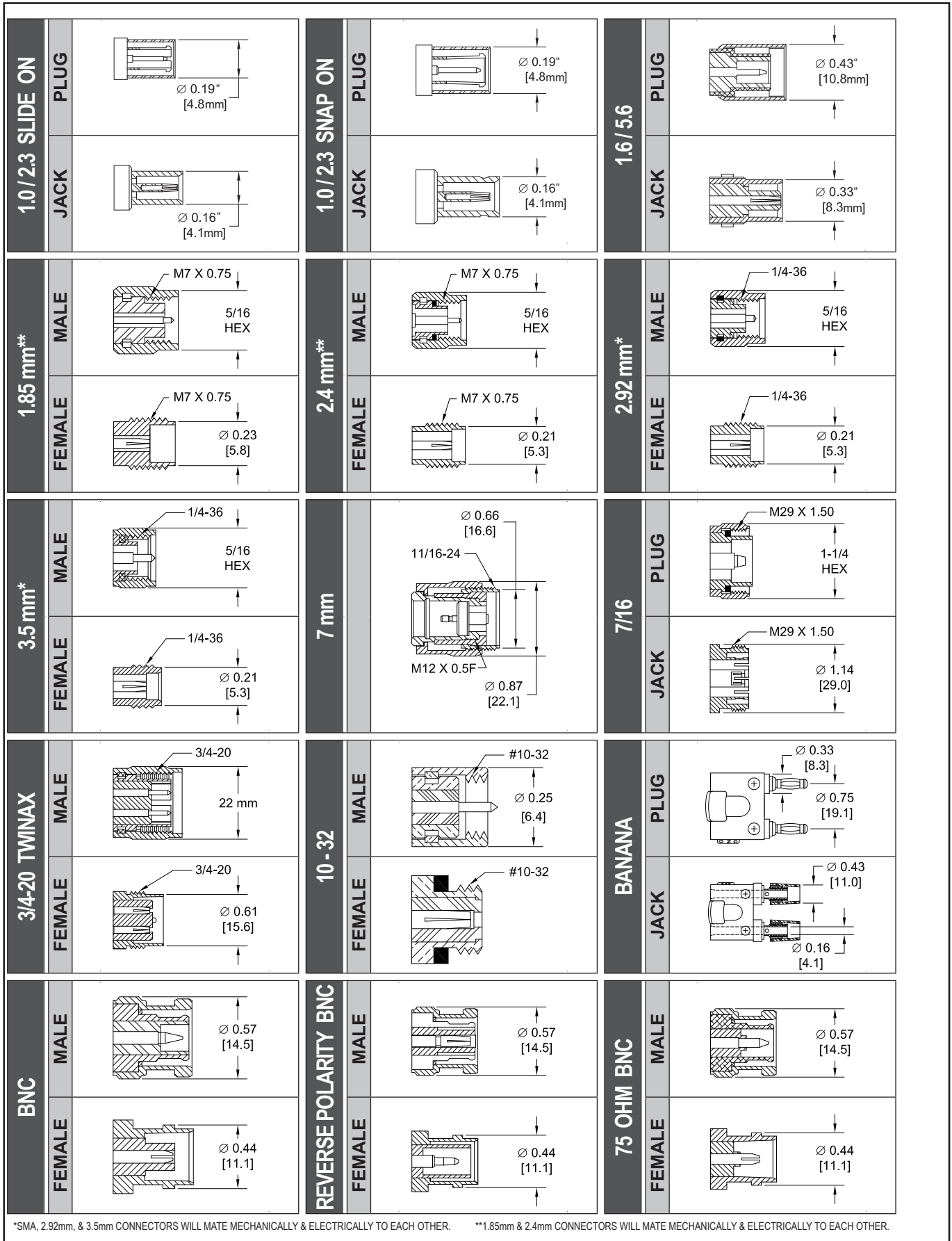

Figure 20.46A — Connector side views, set 1 of 4. [Courtesy of Pasternak]

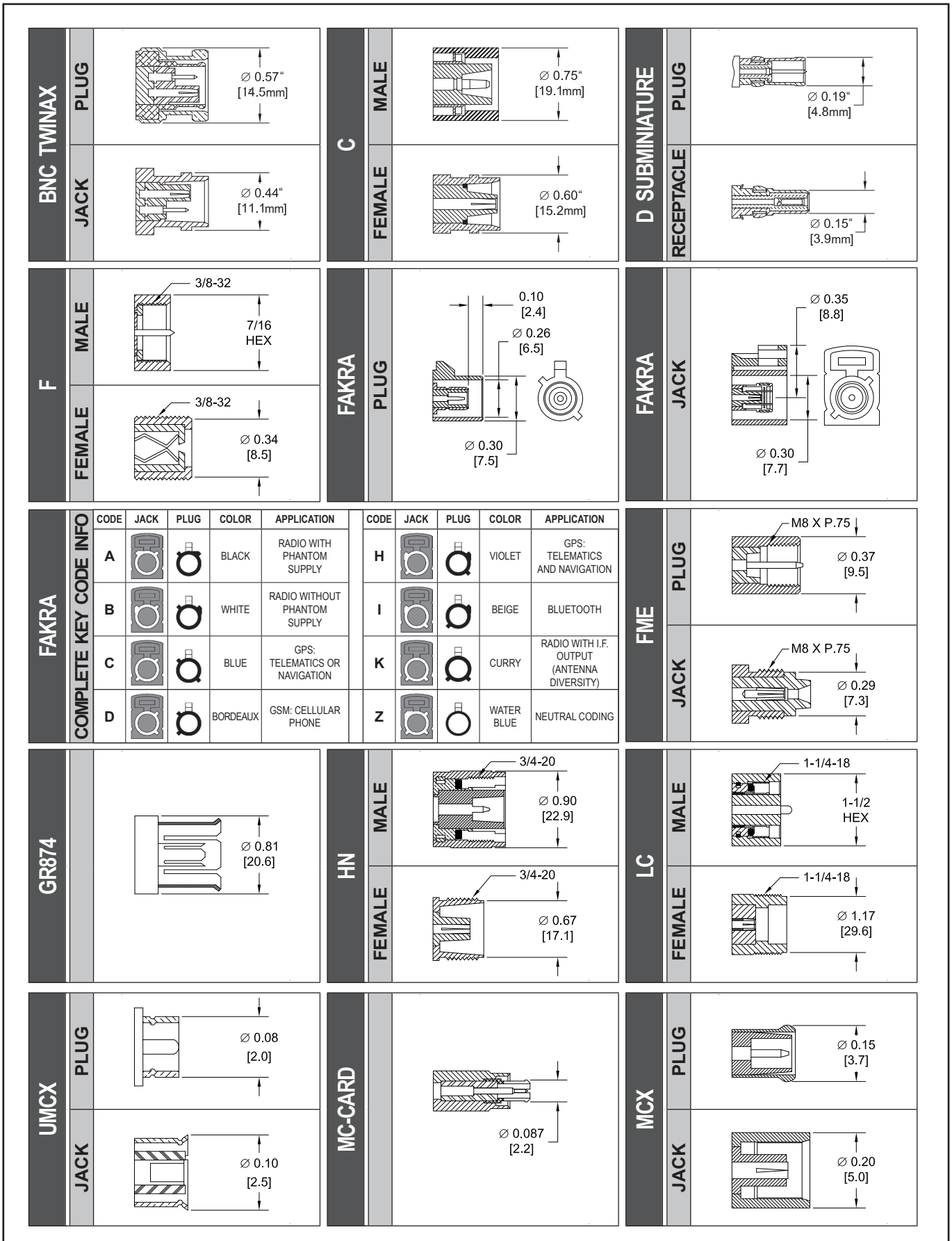

Figure 20.46B — Connector side views, set 2 of 4. [Courtesy of Pasternak]

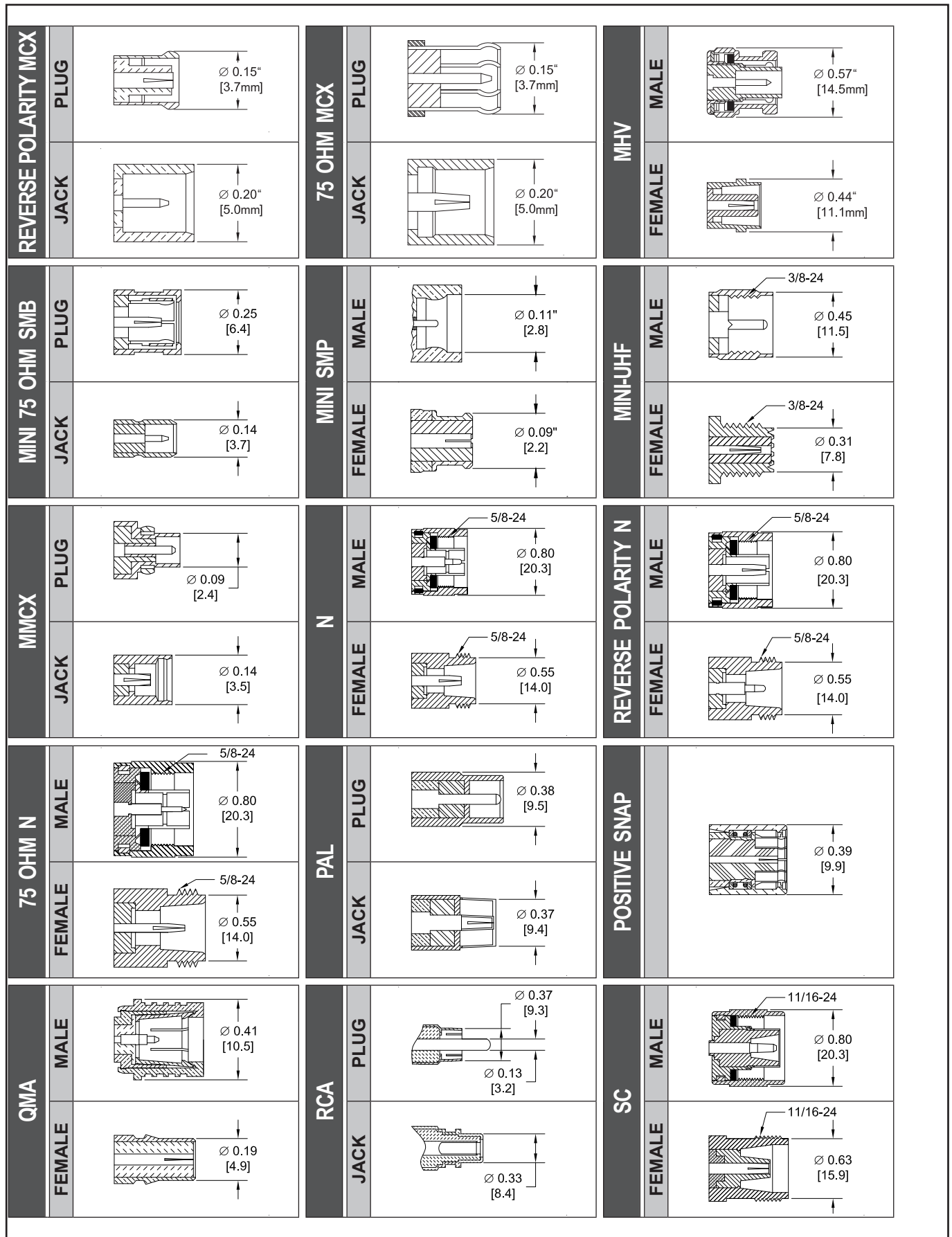

Figure 20.46C — Connector side views, set 3 of 4. [Courtesy of Pasternak]

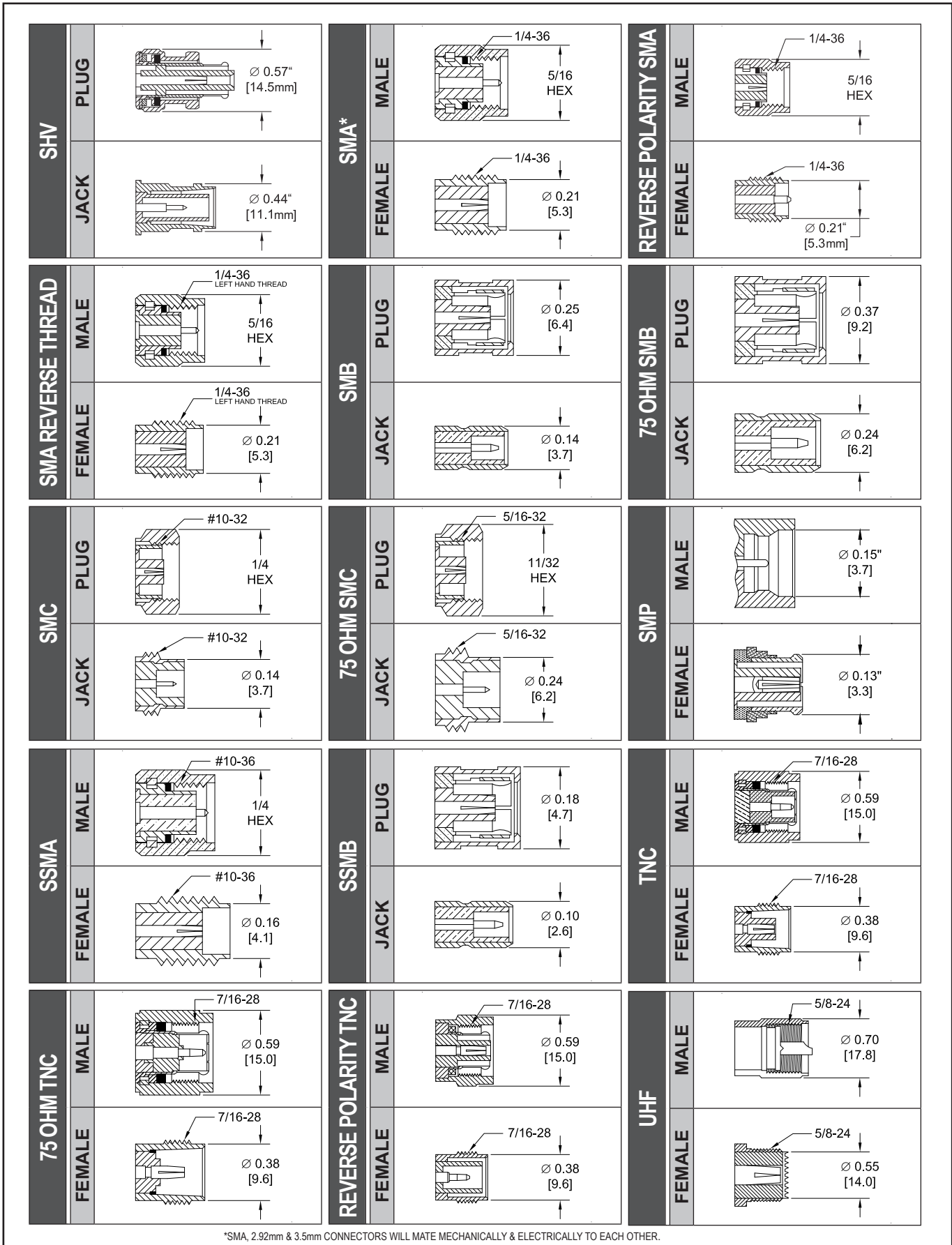
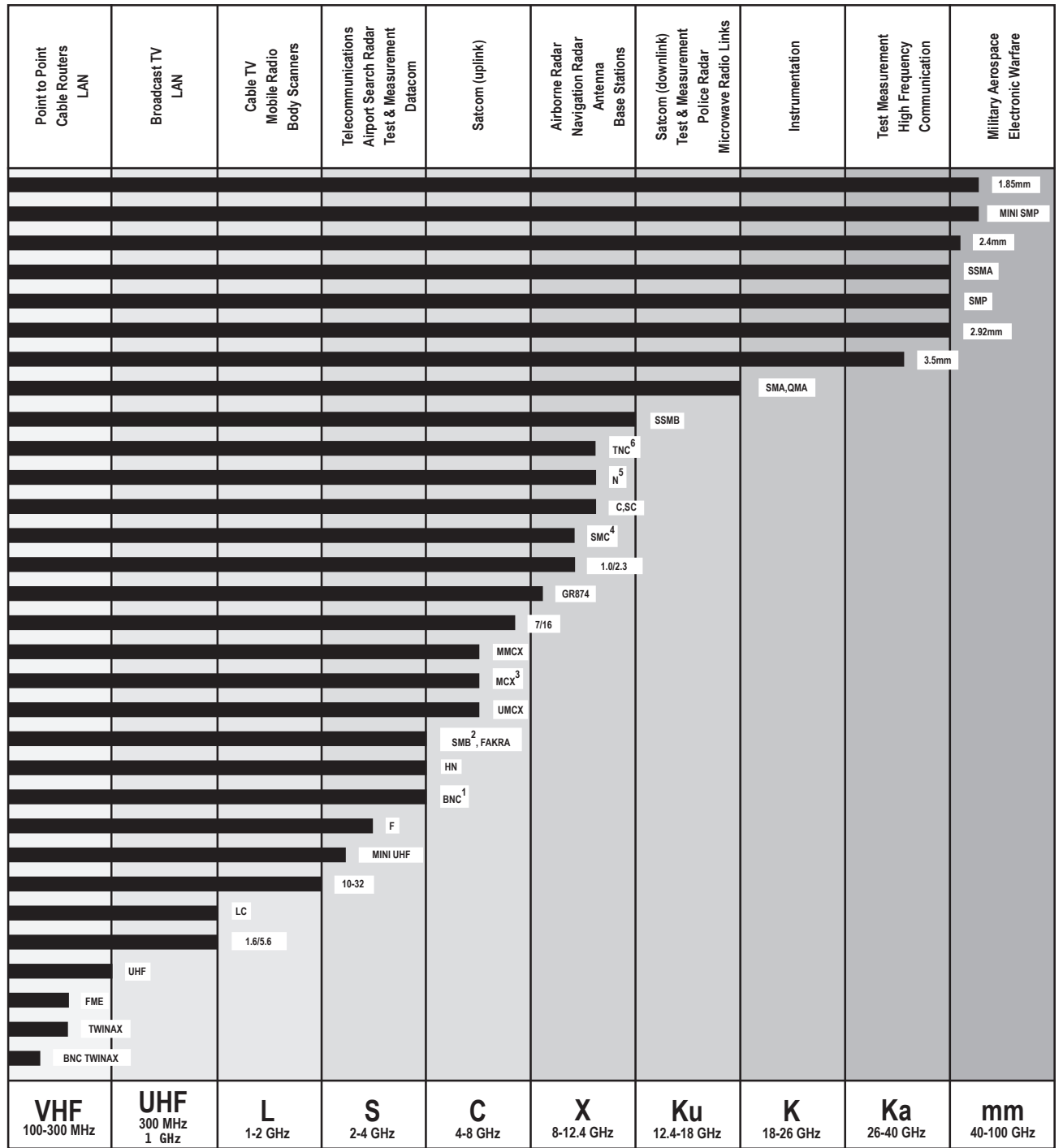

Figure 20.46D — Connector side views, set 4 of 4. [Courtesy of Pasternak]



**Notes:**

- 1: BNC-75 Ohm connectors operate up to 1 GHz
- 2: SMB-75 Ohm & Mini SMB-75 Ohm connectors operate up to 4 GHz
- 3: MCX-75 Ohm connectors operate up to 6 GHz
- 4: SMC-75 Ohm connectors operate up to 10 GHz
- 5: N-75 Ohm connectors operate up to 1.5 GHz
- 6: TNC-75 Ohm connectors operate up to 1 GHz

Figure 20.47 — Recommended frequency ranges by connector type. [Courtesy of Pasternak]

