

Contents

- 21.1 Antenna Basics
 - 21.1.1 Directivity and Gain
 - 21.1.2 Antenna Polarization
 - 21.1.3 Current and Voltage Distribution
 - 21.1.4 Impedance
 - 21.1.5 Impedance and Height Above Ground
 - 21.1.6 Antenna Bandwidth
 - 21.1.7 Effects of Conductor Diameter
 - 21.1.8 Radiation Patterns
 - 21.1.9 Elevation Angle
 - 21.1.10 Imperfect Ground
 - 21.1.11 Antenna Modeling
- 21.2 Dipoles and the Half-Wave Antenna
 - 21.2.1 Radiation Characteristics
 - 21.2.2 Feed Methods
 - 21.2.3 Feed Point Baluns
 - 21.2.4 Building Dipoles and Other Wire Antennas
 - 21.2.5 Bent Dipoles
 - 21.2.6 Inverted-V Dipole
 - 21.2.7 Sloping Dipole
 - 21.2.8 End-Fed Half-Wave (EFHW)
 - 21.2.9 Inductively Loaded Dipoles
 - 21.2.10 Folded Dipoles
 - 21.2.11 Parallel (Fan) Dipoles
 - 21.2.12 Trap Dipoles
 - 21.2.13 Dipoles for NVIS
 - 21.2.14 Off-Center-Fed (OCF) Dipoles
 - Project: Multiband Center-Fed Dipole*
 - Project: 40 to 15 Meter Dual-Band Dipole*
 - Project: W4RNL Rotatable Dipole Inverted-U Antenna*
 - Project: Two W8NX Multiband, Coax-Trap Dipoles*
 - Project: Triband Dipole for 30, 17, and 12 Meters*
- 21.3 Vertical (Ground-Plane) Antennas
 - 21.3.1 Ground Systems
 - 21.3.2 Full-Size Vertical Antennas
 - 21.3.3 Physically Short Verticals
 - Project: Top-Loaded Low-Band Antenna*
 - 21.3.4 Cables and Control Wires on Towers
 - 21.3.5 Multiband Trap Verticals
- 21.4 T and Inverted-L Antennas
- 21.5 Slopers and Vertical Dipoles
 - 21.5.1 Half-Sloper Antenna
 - 21.5.2 Half-Wave Vertical Dipole
 - Project: Half-Wave Vertical Dipole (HVD)*
 - Project: Compact Vertical Dipole (CVD)*
 - Project: All-Wire 30 Meter CVD*
- 21.6 Yagi Antennas
 - 21.6.1 Parasitic Excitation
 - 21.6.2 Yagi Gain, Front-to-Back Ratio, and SWR
 - 21.6.3 Two-Element Beams
 - 21.6.4 Three-Element Beams
 - 21.6.5 Construction of Yagi Antennas
 - Project: Family of Computer-Optimized HF Yagis*
- 21.7 Quad and Loop Antennas
 - Project: Five-Band, Two-Element HF Quad*
 - 21.7.1 Large Loop Antennas
 - 21.7.2 Small Transmitting Loop Antennas
 - Project: Low-Band Quad and Delta Loops*
 - Project: Two-Band Loop for 30 and 40 Meters*
 - Project: Multiband Horizontal Loop Antenna*
- 21.8 HF Mobile Antennas
 - 21.8.1 Simple Whips
 - 21.8.2 Coil-Loaded Whips
 - 21.8.3 Base vs Center vs Continuous Loading
 - 21.8.4 Top-Loaded Whips
 - 21.8.5 Remotely Controlled HF Mobile Antennas
 - 21.8.6 Ground Losses
 - 21.8.7 Antenna Mounting
 - 21.8.8 Mobile HF Antenna Matching
 - 21.8.9 Remotely-Tuned Antenna Controllers
 - 21.8.10 Efficiency
 - Project: Mounts for Remotely Tuned Antennas*
 - Project: Retuning a CB Whip Antenna*
- 21.9 VHF/UHF Mobile Antennas
 - 21.9.1 VHF/UHF Mobile Antenna Mounts
 - 21.9.2 VHF/UHF Mobile Antennas for SSB and CW
- 21.10 VHF/UHF Antennas
 - 21.10.1 Gain
 - 21.10.2 Radiation Pattern
 - 21.10.3 Height Gain
 - 21.10.4 Physical Size
 - 21.10.5 Polarization
 - 21.10.6 Circular Polarization
 - 21.10.7 Transmission Lines
 - 21.10.8 Impedance Matching
 - 21.10.9 Baluns and Impedance Transformers
 - Project: Simple, Portable Ground-Plane Antenna*
 - Project: Coaxial Dipole for VHF or UHF*
- 21.11 VHF/UHF Beams
 - 21.11.1 Stacking Yagis
 - Project: Three and Five-Element Yagis for 6 Meters*
 - Project: Medium-Gain 2 Meter Yagi*
 - Project: Utility Yagi for 432 MHz*
 - Project: Cheap Yagis by WA5VJB*
 - Project: Fixed Moxons for Satellite Operation*
- 21.12 Radio Direction Finding Antennas
 - 21.12.1 RDF Antennas for HF Bands
 - 21.12.2 Methods for VHF/UHF RDF
- 21.13 Rotators
 - 21.13.1 Rotator Ratings
 - 21.13.2 Types of Rotators
 - 21.13.3 Rotator Control
- 21.14 References and Bibliography

Chapter 21

Antennas

In the world of radio, the antenna is “where the rubber meets the road!” With antennas so fundamental to communication, it is important that the amateur have a basic understanding of their function. That understanding enables effective selection and application of basic designs to whatever communications task is at hand. In addition, the amateur is then equipped to engage in one of the most active areas of amateur experimentation, antenna design. The goal of this chapter is to define and illustrate the fundamentals of antennas and provide a selection of basic designs: simple

verticals and dipoles, quads and Yagi beams, and other antennas, plus a section on rotator use and selection. The reader will find additional in-depth coverage of these and other topics in the *ARRL Antenna Book* and other references provided. This chapter was originally written by Chuck Hutchinson, K8CH, and has been updated by Ward Silver, NØAX. Alan Applegate, KØBG, maintains the material on mobile antennas. The section on Radio Direction Finding Antennas was written by Joe Moell, KØOV.

Chapter 21 — Online Content

Articles

- A Simple Direction-Finding Receiver for 80 Meters by Dale Hunt, WB6BYU
- A Simple Broadband Dipole for 80 Meters by Frank Witt AI1H
- A Wideband 80-Meter Dipole by Rudy Severns N6LF
- Broad-Band 80-Meter Antenna by Allen Harbach WA4DRU
- Design of a Two-band Loaded Dipole Antenna by David Birnbaum, K2LYV
- Direction Finding Techniques by Joe Moell, KØOV
- Half-Wave and Multiband Dipole Azimuth and Elevation Patterns
- Small Gap-Resonated Loop Antennas by Kai Siwiak KE4PT and Richard Quick W4RQ
- The 3/8-Wavelength Vertical — A Hidden Gem by Joe Reisert, W1JR
- The Fan Dipole as a Wideband and Multiband Antenna Element by Joel Hallas W1ZR
- Weatherizing Outdoor Inductors and Traps by Dick Sander, K5QY
- Workshop Chronicles: Alloy Designations by Don Daso, K4ZA

HF Projects

- A Compact Multiband Dipole by Zack Lau W1VT
- A No Compromise Off-Center Fed Dipole for Four Bands by Rick Littlefield, K1BQT
- An Off-Center End-Fed Dipole for Portable Operation on 40 to 6 Meters by Kai Siwiak, KE4PT
- Extended Double-Zepp for 17 Meters
- Five-Band Two-Element Quad by Al Doig, W6NBH, and William Stein, KC6T

- Having a Field Day with the Moxon Rectangle, by L.B. Cebik, W4RNL
- The J78 Antenna: An Eight-band Off-Center-Fed HF Dipole by Brian Machesney, K1LI/J75Y
- The Trimox — A Moxon Tribander for a Holiday DXpedition by Brian Machesney, K1LI
- The W4SSY Spudgun by Byron Black, W4SSY
- Top-Loaded Low-Band Antenna Construction Details by Dick Stroud, W9SR
- Triband Dipole for 30, 17, and 12 Meters by Zack Lau W1VT
- Two-Band Loop for 30 and 40 Meters by James Brenner, NT4B
- Two W8NX Multiband, Coax-Trap Dipoles
- Wire Quad for 40 Meters by Dean Straw, N6BV

VHF and UHF Projects

- 6-Meter Halo Antenna for DXing by Jerry Clement, VE6AB
- A New Spin on the Big Wheel by L.B. Cebik, W4RNL, and Bob Cerreto, WA1FXT
- A Simple Fixed Antenna for VHF/UHF Satellite Work, by L.B. Cebik, W4RNL
- A Small 70-cm Yagi by Zack Lau, W1VT
- A True Plumber's Delight for 2 Meters — An All-Copper J-Pole by Michael Hood, KD8JB
- Cheap Antennas for the AMSAT LEOs by Kent Britain, WA5VJB
- Dual-Band Antenna for 146/446 MHz by Wayne Bartholomew, K3MF
- Medium-Gain 2 Meter Yagi by L.B. Cebik, W4RNL
- Quick and Cheap Omni Antenna for 1296 MHz by Paul Wade, W1GHZ

21.1 Antenna Basics

This section covers a range of topics that are fundamental to understanding how antennas work and defines several key terms. (A glossary is included in this book's online content.) While the discussion in this section uses the dipole as the primary example, the concepts apply to all antennas.

21.1.1 Directivity and Gain

All antennas, even the simplest types, exhibit directive effects in that the intensity of radiation is not the same in all directions from the antenna. This property of radiating more strongly in some directions than in others is called the *directivity* of the antenna. Directivity is the

same for receiving as transmitting.

The directive pattern of an antenna at a given frequency is determined by its size and shape and on its position and orientation relative to the Earth and any other reflecting or absorbing surfaces.

The more an antenna's directivity is enhanced in a particular direction, the greater the *gain* of the antenna. This is a result of the radiated energy being concentrated in some directions at the expense of others. Similarly, gain describes the ability of the antenna to receive signals preferentially from certain directions. Gain does not create additional power beyond that delivered by the feed line — it only focuses that energy.

Gain is usually expressed in decibels, and is always stated with reference to a *standard* antenna — usually a dipole or an *isotropic radiator*. An isotropic radiator is a theoretical antenna that would, if placed in the center of an imaginary sphere, evenly illuminate that sphere with radiation. The isotropic radiator is an unambiguous standard, and for that reason is frequently used as the comparison for gain measurements.

When the reference for gain is the isotropic radiator in *free space*, gain is expressed in dBi. When the standard is a dipole also located in free space, gain is expressed in dBd. Because the dipole has some gain (2.15 dB with respect to the isotropic antenna as explained in the section on dipoles) in its favored direction, its gain can be expressed as 2.15 dBi. Gain in dBi can be converted to dBd by subtracting 2.15 dB and from dBd to dBi by adding 2.15 dB.

Gain also takes losses in the antenna or surrounding environment into account. For example, if a practical dipole antenna's wire element dissipated 0.5 dB of the transmitter power as heat, that specific dipole's gain with respect to an isotropic antenna would be $2.15 - 0.5 = 1.65$ dBi.

21.1.2 Antenna Polarization

An electromagnetic wave has two components: an electric field and a magnetic field at right angles to each other. For most antennas, the field of primary interest is the electric, or *E-field*. The magnetic field is called the *H-field*. (The abbreviations E- and H- come from Maxwell's equations that describe electromagnetic waves.) By convention, the orientation of the E-field is the reference for determining the electromagnetic wave's *polarization*. The E-field of an electromagnetic wave can be oriented in any direction, so orientation with respect to the Earth's surface is the usual frame of reference. The wave's polarization can be vertical, horizontal, or some intermediate angle. If the E- and H-field orientations rotate as the wave travels, that is elliptical or circular polarization.

Antennas are also considered to have

polarization determined by the orientation of the E-field of the electromagnetic field radiated by the antenna. Because the E-field of the radiated wave is parallel to the direction of current flow in the antenna's elements, the polarization of the wave and the orientation of the antenna elements is usually the same. For example, the E-field radiated by an antenna with linear elements is parallel to those elements, so that the polarization of the radiated wave is the same as the orientation of the elements. (This is somewhat over-simplified, and additional considerations apply for elements that are not linear.) Thus a radiator that is parallel to the Earth radiates a horizontally polarized wave, while a vertical antenna radiates a vertically polarized wave. If a wire antenna is slanted, it radiates waves with an E-field that has both vertical and horizontal components.

Antennas function symmetrically — a received signal will create the strongest antenna current when the antenna's elements are parallel to the E-field of the incoming wave, just as the radiated wave's E-field will be strongest parallel to current in the antenna's radiating elements. This also means that for the strongest received signal, the antenna elements should have the same polarization as that of the incoming wave. Misalignment of the receiving antenna's elements with the passing wave's E-field reduces the amount of signal received. This is called *cross-polarization*. When the polarizations of antenna and wave are at right angles, very little antenna current is created by the incoming signal.

For best results in line-of-sight communi-

cations, antennas at both ends of the circuit should have the same polarization. However, it is not essential for both stations to use the same antenna polarity for ionospheric propagation or sky wave (see the **Propagation** chapter). This is because the radiated wave is bent and rotated considerably during its travel through the ionosphere. At the far end of the communications path the wave may be horizontal, vertical, or somewhere in between at any given instant. For that reason, the main consideration for a good DX antenna is a low angle of radiation rather than the polarization.

Most HF-band antennas are either vertically or horizontally polarized. Although circular polarization is possible, just as it is at VHF and UHF, it is seldom used at HF. While most amateur antenna installations use the Earth's surface as their frame of reference, in cases such as satellite communication or EME the terms "vertical" and "horizontal" have no meaning with respect to polarization.

21.1.3 Current and Voltage Distribution

Using the dipole as an example, when power is fed to an antenna, the current and voltage vary along its length. The current is minimum at the ends, regardless of the antenna's length. The current does not actually reach zero at the current minima, because of capacitance at the antenna ends, and support wires all contribute to this capacitance, which is also called the *end effect*. The opposite is true of the RF voltage. That is, there is a voltage maximum at each end.

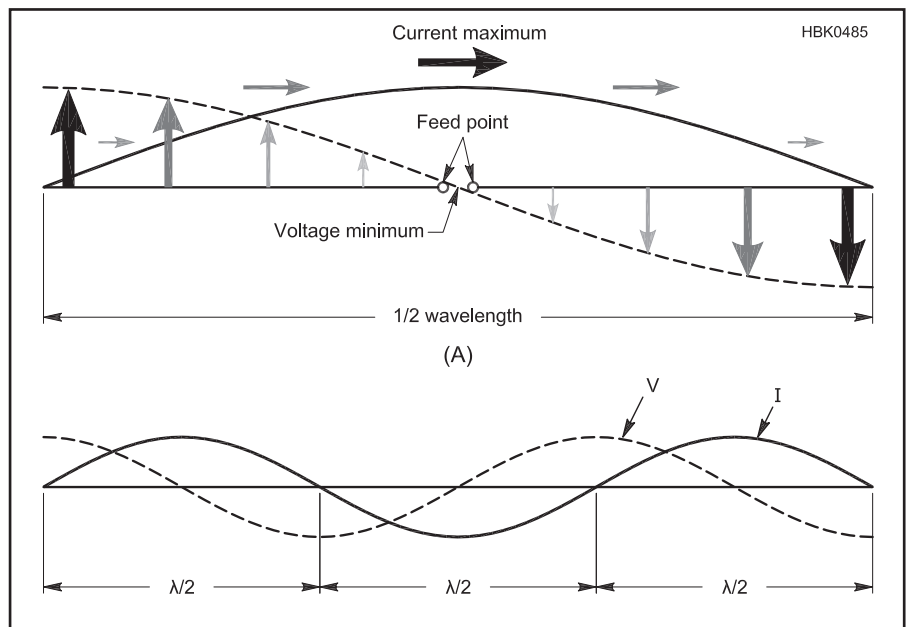

Figure 21.1 — The magnitude of current and voltage along a half-wave dipole (A) and for an antenna made from a series of half-wave dipoles (B). Both antennas are shown operating at a resonant frequency. Non-resonant antennas will exhibit a different pattern of voltage and current.

In the case of a half-wave dipole at its resonant frequency there is a current maximum at the center and a voltage minimum at the center, as illustrated in **Figure 21.1**. The graphs of current and voltage along the wire represent the magnitude of the current and voltage waveforms similarly to the envelope of a modulated signal. The magnitude of the voltage and current distributions are 90° out of phase, although the actual current and voltage waveforms are in phase, resulting in a purely resistive feed point impedance.

The pattern of alternating current and voltage maxima a quarter-wavelength apart repeats every half-wavelength along a resonant linear antenna, as shown in Figure 21.1B. The phase of the current and voltage are inverted in each successive half-wavelength section. (If the antenna is non-resonant, there will still be a current minimum at an open end but the voltage and current patterns on the antenna will be different than shown here.)

Power is dissipated as heat or as signals by the resistance of the antenna, which consists of both the RF resistance of the wire (ohmic loss resistance) and the *radiation resistance*. The radiation resistance is the equivalent resistance that would dissipate the power the antenna radiates, with a current flowing in it equal to the antenna current at a current maximum. Radiation resistance represents the work done by creating current in the antenna that transfers the energy from the signal source to the radiated electromagnetic wave. The loss resistance of a half-wave antenna is ordinarily small, compared with the radiation resistance, and can usually be neglected for practical purposes except in electrically small antennas, such as mobile HF antennas.

21.1.4 Impedance

The *impedance* at a given point in the antenna is determined by the ratio of the voltage to the current at that point. For example, if there were 100 V and 1.4 A of RF current at a specified point in an antenna and if they were in phase, the impedance would be approximately 71 Ω. The antenna's *feed point impedance* is the impedance at the point where the feed line is attached. If the feed point location changes, so does the feed point impedance.

Antenna impedance may be either resistive or complex (that is, containing resistance and reactance). The impedance of a *resonant* antenna is purely resistive anywhere on the antenna, no matter what value that impedance may be. For example, the impedance of a resonant half-wave dipole may be low at the center of the antenna and high at the ends, but it is purely resistive in all cases, even though its magnitude changes.

The feed point impedance is important in determining the appropriate method of matching the impedance of the antenna and the

transmission line. The effects of mismatched antenna and feed line impedances are described in detail in the **Transmission Lines** chapter of this book. Some mistakenly believe that a mismatch, however small, is a serious matter. This is not true. The significance of a perfect match becomes more pronounced only at VHF and higher, where feed line losses are a major factor. Minor mismatches at HF are rarely significant.

21.1.5 Impedance and Height Above Ground

The feed point impedance of an antenna varies with height above ground because of the effects of energy reflected from and absorbed by the ground. For example, a ½ λ (or half-wave) center-fed dipole will have a feed point impedance of approximately 75 Ω in free space far from ground, but **Figure 21.2** shows that only at certain electrical heights above ground will the feed point impedance be 75 Ω. The feed point impedance will vary from very low when the antenna is close to the ground to a maximum of nearly 100 Ω at 0.34 λ above ground, varying between ±5 Ω as the antenna is raised farther. The 75 Ω feed point impedance is most likely to be realized in a practical installation when the horizontal dipole is approximately ½, ¾ or 1 wavelength above ground. This is why few amateur λ/2 dipoles exhibit a center-fed feed point impedance of 75 Ω, even though they may be resonant.

Figure 21.2 compares the effects of perfect ground and typical soil at low antenna heights. The effect of height on the radiation resistance of a horizontal half-wave antenna is not drastic so long as the height of the antenna is greater than 0.2 λ. Below this height, while decreasing rapidly to zero over perfectly con-

ducting ground, the resistance decreases less rapidly with height over actual lossy ground. At lower heights the resistance stops decreasing at around 0.15 λ, and thereafter increases as height decreases further. The reason for the increasing resistance is that more and more energy from the antenna is absorbed by the ground as the height drops below ¼ λ, seen as an increase in feed point impedance.

21.1.6 Antenna Bandwidth

The *bandwidth* of an antenna refers generally to the range of frequencies over which the antenna exhibits a specified level of performance. The bandwidth can be specified in units of frequency (MHz or kHz) or as a percentage of the antenna's design frequency.

Popular amateur usage of the term antenna bandwidth most often refers to the 2:1 *SWR bandwidth*, such as, "The 2:1 SWR bandwidth is 3.5 to 3.8 MHz" or "The antenna has a 10% SWR bandwidth" or "On 20 meters, the antenna has an SWR bandwidth of 200 kHz." Other specific bandwidth terms are also used, such as the *gain bandwidth* (the bandwidth over which gain is greater than a specified level) and the *front-to-back ratio bandwidth* (the bandwidth over which front-to-back ratio is greater than a specified level).

As operating frequency is lowered, an equivalent bandwidth in percentage becomes narrower in terms of frequency range in kHz or MHz. For example, a 5% bandwidth at 21 MHz is 1.05 MHz (more than wide enough to cover the whole band) but at 3.75 MHz only 187.5 kHz! Because of the wide percentage bandwidth of the lower frequency bands (160 meters is 10.5% wide, 80 meters is 3.4% wide), it is difficult to design an antenna with a bandwidth sufficient to include the whole band.

It is important to recognize that SWR bandwidth does not always relate directly to gain bandwidth. Depending on the amount of feed line loss, an 80 meter dipole with a relatively narrow 2:1 SWR bandwidth can still radiate a good signal at each end of the band, provided that an antenna tuner is used to allow the transmitter to load properly and feed line loss is not excessive. Broadbanding techniques, such as fanning the far ends of a dipole to simulate a conical type of dipole, can help broaden the SWR bandwidth.

21.1.7 Effects of Conductor Diameter

The impedance and resonant frequency of an antenna also depend on the diameter of the conductors that make up its elements in relation to the wavelength. As the diameter of a conductor increases, its capacitance per unit length increases and inductance per unit length decreases. This has the net effect of lowering

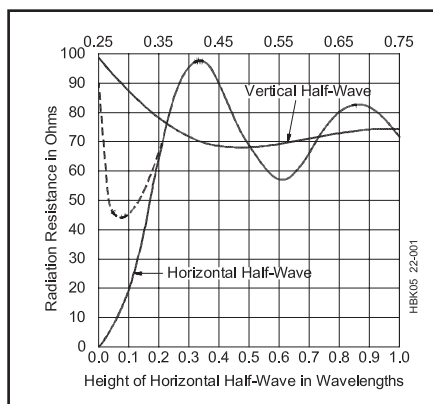

Figure 21.2 — Curves showing the radiation resistance of vertical and horizontal half-wavelength dipoles at various heights above ground. The broken-line portion of the curve for a horizontal dipole shows the resistance over average real ground, the solid line for perfectly conducting ground.

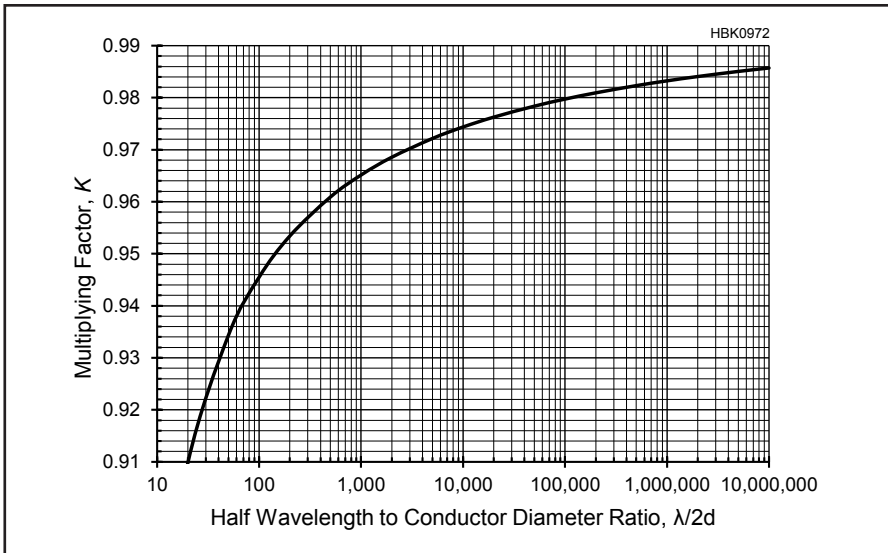

Figure 21.3 — Effect of antenna diameter on length for half-wavelength resonance in free-space, shown as a multiplying factor, K . The thicker the conductor relative to the wavelength, the shorter the physical length of the antenna at resonance. For antennas over ground, additional factors affect the antenna's electrical length.

the frequency at which the antenna element is resonant, as illustrated in **Figure 21.3**. The larger the conductor diameter in terms of wavelength, the smaller its *length-to-diameter ratio* (l/d) and the lower the frequency at which a specific length of that conductor is $\frac{1}{2}$ wavelength long electrically, in free space.

K FACTOR

Based on the standard value for the speed of light, the wavelength λ of an electromagnetic wave in free-space at frequency f is given by:

$$\lambda(\text{in feet}) = \frac{983.571}{f(\text{in MHz})} \quad (1A)$$

and for one-half wavelength:

$$\frac{\lambda}{2}(\text{in feet}) = \frac{491.786}{f(\text{in MHz})} \quad (1B)$$

A dipole with a length of exactly one-half of a free-space wavelength $\lambda/2$ has an impedance of $73.079 + j42.515 \Omega$, essentially independent of wire diameter. The dipole must be shortened to achieve resonance where reactance is equal to zero. As the diameter of a conductor increases, its capacitance per unit length increases and inductance per unit length decreases. This increases the ratio of stored electric field energy to magnetic field energy, with the result of lowering the frequency at which the antenna element is resonant. Stated another way: For a given frequency, the larger a conductor's diameter, the lower the frequency at which a dipole made of that conductor is resonant.

A dipole's resonant length is given by the product of the free-space half-wavelength and a constant,

$$L_{\text{Resonant}}(\text{in feet}) = K \times \frac{491.786}{f(\text{in MHz})} \quad \text{or} \quad (2)$$

$$L_{\text{Resonant}}(\text{in inches}) = K \times \frac{5901.43}{f(\text{in MHz})}$$

where K is a constant between zero and one, $0 < K < 1$, that depends on the dipole's "fatness" or "thickness." There are several ways to express dipole thickness. Antenna builders prefer to specify dipole thickness in terms of the half-wavelength-to-diameter ratio $(\lambda/2)/d$ because a builder generally knows d and wants to calculate L . The graph in **Figure 21.3** satisfies this need and allows dipole resonant length to be determined for a given physical thickness and frequency. Most half-wavelength dipoles at HF typically have $(\lambda/2)/d$ ratios in the range of 2500 to 25,000 with values of K from 0.97 to 0.98.

The graph shown in **Figure 21.3** and Eq 2A below were determined by Steve Stearns, K6OIK, who evaluated and compared theoretical and numerical methods for calculating dipole and monopole impedance. (See the Bibliography entries for Stearns, Tai and Long, Elliott, and Schelkunoff.) If better accuracy than the graph is needed, the formula in Eq 2A should be used. (A more complete discussion of the K factor and related topics is provided in the *ARRL Antenna Book's* 24th edition.)

$$K = 1 - \frac{0.225706}{\ln\left(\frac{\lambda/2}{d}\right) - 0.429451} \quad (2A)$$

Example 1: A half-wavelength dipole for

7.2 MHz has an uncorrected length of $491.786 / 7.2 = 68.3$ feet. If it is made from #12 AWG wire (0.081 inch diameter), it has a $(\lambda/2)/d$ ratio of:

$$\frac{491.786}{7.2}(\text{ft}) \times \frac{12 \text{ in/ft}}{0.081 \text{ in}} = 10,119$$

From **Figure 21.3** or Eq 2A, a $(\lambda/2)/d$ ratio of 10,119 gives $K = 0.974$. Thus, by Eq 2, the resonant length of the half-wavelength dipole is $0.974 \times 68.3 = 66$ feet 7 inches.

It should be understood that K is not a velocity factor because it is unrelated to waves or the speed of wave travel. Rather, K arises because if a dipole is exactly one-half wavelength long, the stored energies in the electric and magnetic fields are not exactly equal. A dipole must be shortened to obtain equality and resonance.

21.1.8 Radiation Patterns

Radiation patterns are graphic representations of an antenna's directivity. Two examples are given in **Figures 21.4** and **21.5**. Shown in polar coordinates (see the **Radio Mathematics** online supplement for information about polar coordinates), the angular scale shows direction, and the scale from the center of the plot to the outer ring, calibrated in dB, shows the relative strength of the antenna's radiated signal (gain) at each

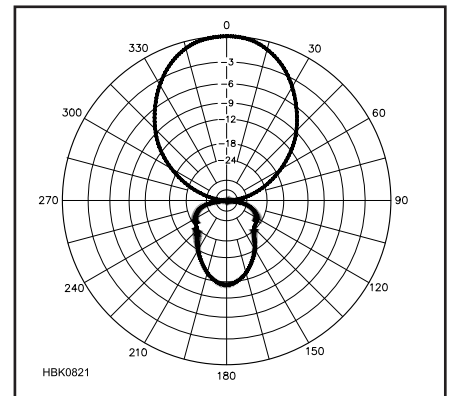

Figure 21.4 — Azimuthal pattern of a typical three-element Yagi beam antenna in free space. The Yagi's boom is along the 0° to 180° axis.

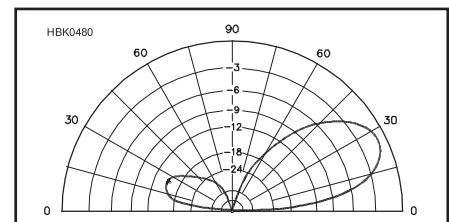

Figure 21.5 — Elevation pattern of a three-element Yagi beam antenna placed $\frac{1}{2} \lambda$ above perfect ground.

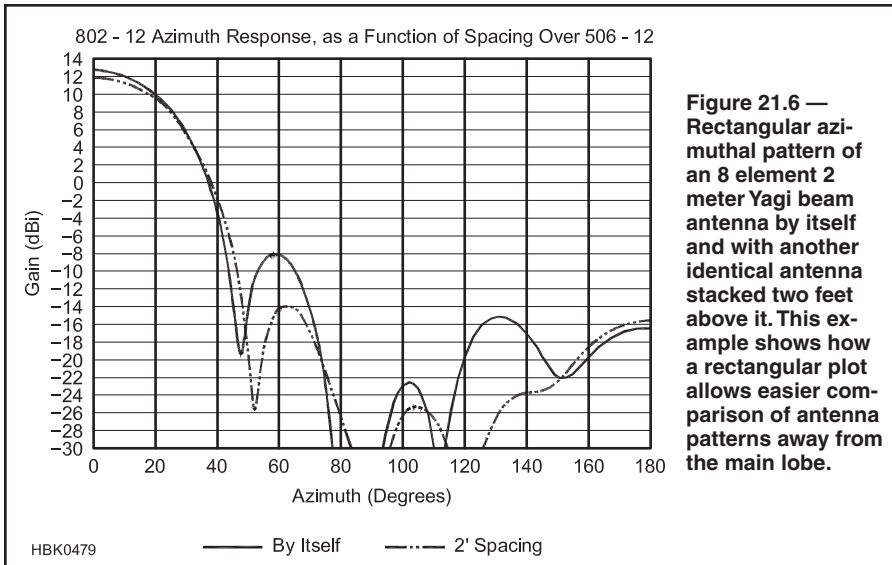

Figure 21.6 — Rectangular azimuthal pattern of an 8 element 2 meter Yagi beam antenna by itself and with another identical antenna stacked two feet above it. This example shows how a rectangular plot allows easier comparison of antenna patterns away from the main lobe.

angle. A line is plotted showing the antenna’s relative gain (transmitting and receiving) at each angle. The antenna is located at the exact center of the plot with its orientation specified separately.

The pattern is composed of *nulls* (angles at which a gain minimum occurs) and *lobes* (a range of angles in which a gain maximum occurs). The *main lobe* is the lobe with the highest amplitude unless noted otherwise and unless several plots are being compared the peak amplitude of the main lobe is placed at the outer ring as a 0 dB reference point. The peak of the main lobe can be located at any angle. All other lobes are *side lobes* which can be at any angle, including to the rear of the antenna.

Figure 21.4 is an *azimuthal* or *azimuth pattern* that shows the antenna’s gain in all horizontal directions (azimuths) around the antenna. As with a map, 0° is at the top and bearing angle increases clockwise. (This is different from polar plots generated for mathematical functions in which 0° is at the right and angle increases counterclockwise.)

Figure 21.5 is an *elevation pattern* that shows the antenna’s gain at all vertical angles. In this case, the horizon at 0° is located to both sides of the antenna and the zenith (directly overhead) at 90°. The plot shown in Figure 21.5 assumes a ground plane (drawn from 0° to 0°), but in free-space the plot would include the missing semicircle with -90° at the bottom. Without the ground reference, the term “elevation” has little meaning, however.

You’ll also encounter E-plane and H-plane radiation patterns. These show the antenna’s radiation pattern in the plane parallel to the E-field or H-field of the antenna. It’s important to remember that the E-plane and H-plane do not have a fixed relationship to the Earth’s surface. For example, the E-plane pattern from a horizontal dipole is an azimuthal pattern, but if the same dipole is oriented vertically, the

E-plane pattern becomes an elevation pattern.

Antenna radiation patterns can also be plotted on rectangular coordinates with gain on the vertical axis in dB and angle on the horizontal axis as shown in **Figure 21.6**. This is particularly useful when several antennas are being compared. Multiple patterns in polar coordinates can be difficult to read, particularly close to the center of the plot.

The amplitude scale of antenna patterns is almost always in dB. The scale rings can be calibrated in several ways. The most common is for the outer ring to represent the peak amplitude of the antenna’s strongest lobe as 0 dB. All other points on the pattern represent *relative gain* to the peak gain. The antenna’s *absolute gain* with respect to an isotropic (dBi) antenna or dipole (dBd) is printed as a label somewhere near the pattern. If several antenna radiation patterns are shown on the same plot for comparison, the pattern with the largest gain value is usually assigned the role of 0 dB reference.

The gain amplitude scale is usually divided in one of two ways. The ARRL standard scale has rings at 0, -3, -6, -12, -18, and -24 dB. This makes it easy to see where the gain has fallen to one-half of the reference or peak value (-3 dB), one-quarter (-6 dB), one-sixteenth (-12 dB), and so on. Another popular division of the amplitude scale is 0, -10, -20, -30, and -40 dB with intermediate rings or tick marks to show the -2, -4, -6, and -8 dB levels. You will encounter a number of variations on these basic scales.

RADIATION PATTERN MEASUREMENTS

Given the basic radiation pattern and scales, it becomes easy to define several useful measurements or metrics by which antennas are compared, using their azimuthal patterns. Next to gain, the most commonly used metric for

directional antennas is the *front-to-back ratio* (*F/B*) or just “front-to-back.” This is the difference in dB between the antenna’s gain in the specified “forward” direction and in the opposite or “back” direction. The front-to-back ratio of the antenna in Figure 21.4 is about 11 dB. *Front-to-side ratio* is the difference between the antenna’s “forward” gain and gain at right angles to the forward direction. This assumes the radiation pattern is symmetric, and is of most use to antennas such as Yagis and quads that have elements arranged in parallel planes. The front-to-side ratio of the antenna in Figure 21.4 is more than 30 dB. Because the antenna’s rearward pattern can have large amplitude variations, the *front-to-rear ratio* is sometimes used. Front-to-rear uses the average of rearward gain over a specified angle, usually the 180° semicircle opposite the direction of the antenna’s maximum gain, instead of a single gain figure at precisely 180° from the forward direction.

The antenna’s *beamwidth* is the angle over which the antenna’s main lobe gain is within 3 dB of the peak gain. Stated another way, the beamwidth is the angle between the directions at which the antenna’s gain is -3 dB. In Figure 21.4, the antenna’s main lobe beamwidth is about 54°, since the pattern crosses the -3 dB gain scale approximately 27° to either side of the peak direction. Antenna patterns with comparatively small beamwidths are referred to as “sharp” or “narrow.”

An antenna with an azimuthal pattern that shows equal gain in all directions is called *omnidirectional*. This is not the same as an isotropic antenna that has equal gain in all directions, both vertical both horizontal.

21.1.9 Elevation Angle

For long-distance HF communication, the (vertical) *elevation angle* of maximum radiation, or *radiation angle*, is of considerable importance. You will want to erect your antenna

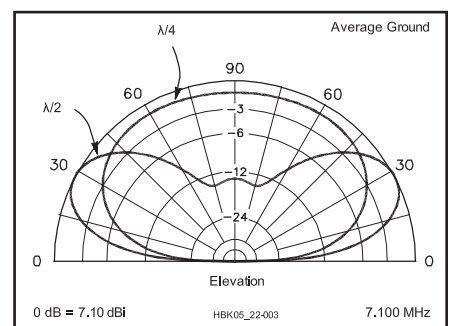

Figure 21.7 — Elevation patterns for two 40 meter dipoles over average ground (conductivity of 5 mS/m and dielectric constant of 13) at ¼λ (33 foot) and ½λ (66 foot) heights. The higher dipole has a peak gain of 7.1 dBi at an elevation angle of about 26°, while the lower dipole has more response at high elevation angles.

so that its strongest radiation occurs at vertical angles resulting in the best performance at the distances over which you want to communicate. In general, the greater the height of a horizontally polarized antenna, the stronger its gain will be at lower vertical angles. **Figure 21.7** shows this effect at work in horizontal dipole antennas. (See the **Propagation of Radio Signals** chapter and the *ARRL Antenna Book* for more information about how to determine the best elevation angles for communication.)

Since low radiation angles usually are most effective for long-distance communications, this generally means that horizontal antennas should be high—higher is usually better. (The optimum angle for intercontinental contacts on the HF bands is generally 15° or lower.) Experience shows that satisfactory results can be attained on the bands above 14 MHz with antenna heights between 40 and 70 feet.

Higher vertical angles can be useful for medium to short-range communications. For example, elevation angles between 20° and 65° are useful on the 40 and 80 meter bands over the roughly 550 mile path between Cleveland and Boston. Even higher angles may be useful on shorter paths when using these lower HF frequencies. A 75 meter dipole between 30 and 70 feet high works well for ranges out to several hundred miles.

For even shorter-range communications centered on your location, such as for emergency communications and regional nets, a very low antenna is used, generating its strongest radiation straight up. This is referred to as *Near-Vertical Incidence Skywave (NVIS)* communication. The antenna should be around 0.2λ above ground, and the frequency used should be below the ionosphere's critical frequency so that the signal is completely reflected back toward the ground over a wide area.

Azimuthal patterns must also specify at what elevation angle the antenna gain is measured or calculated. While an azimuthal pattern may be in the plane of the antenna (an elevation angle of 0°), for antennas located above ground the gain will vary strongly with elevation angle.

21.1.10 Imperfect Ground

Ground (soil) conducts, but is far from being a perfect conductor. This influences the radiation pattern of the antennas that we use. The effect is most pronounced at high vertical angles (the ones most important for short-range communications and least important for

long-distance communications) for horizontally polarized antennas. The consequences for vertical antennas are greatest at low angles, and are quite dramatic as can be clearly seen in **Figure 21.8**, where the elevation pattern for a 40 meter vertical half-wave dipole located over average ground is compared to one located over saltwater. At 10° elevation, the saltwater antenna has about 7 dB more gain than its landlocked counterpart.

An HF vertical antenna may work very well for a ham living in an area with rich soil. Ground of this type has very good conductivity. By contrast, a ham living where the soil is rocky or in a desert area may not be satisfied with the performance of a vertical HF antenna over such poorly conducting ground. Regardless of ground conductivity, the use of a ground screen of radial wires for HF verticals on land is necessary for good results.

When evaluating or comparing antennas, it is also important to include the effects of ground on antenna gain. Depending on height above ground and the qualities of the ground, reflections can increase apparent antenna gain by up to 6 dB. Because the actual installation of the antenna is unlikely to duplicate the environment in which the gain with reflections is claimed or measured, it is preferable to rely on free-space gain measurements or specifications that are independent of reflecting surfaces.

21.1.11 Antenna Modeling

Computer modeling of antennas has made it a lot easier to evaluate antenna performance and design antennas. Most modeling software available to hams is based on *NEC* (Numerical Electromagnetics Code). *NEC* is a general-purpose program, capable of modeling almost any antenna type from simple dipoles to complex Yagis and more. By itself, *NEC* is difficult for non-professionals to use, so software has been developed that provides a more user-friendly interface. The best-known versions are *EZNEC* (eznec.com) and *4nec2* (www.qsl.net/4nec2). Both are available at no cost and run on any recent version of Windows.

NEC uses a *Method of Moments* algorithm. The basic principle is simple: An antenna is broken down into a set of straight-line wire *segments*. The fields resulting from the current in each segment and from the mutual interaction between segments are vector-summed in the far field to create azimuth and elevation-plane patterns. Feed point impedance and other parameters are also calculated. The antenna can

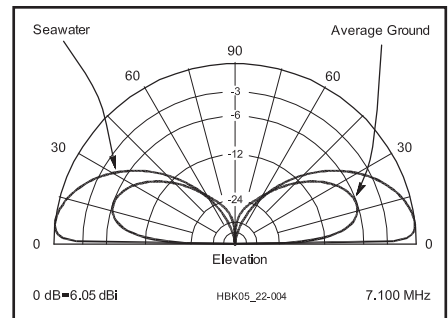

Figure 21.8 — Elevation patterns for a vertical dipole over sea water compared to average ground. In each case the center of the dipole is just over $\frac{1}{4} \lambda$ high. The low-angle response is greatly degraded over average ground compared to sea water, which is virtually a perfect ground.

Antenna Systems for Small Stations

When getting started on HF, one of the most common questions is, “What is the best antenna?” The answer always begins with “It depends!” There are so many possibilities, but the choices frequently come down to a vertical dipole or ground plane versus horizontal dipoles. Many things affect the choice: ground conductivity, terrain, available supports, and esthetics have the most impact. Jim Brown, K9YC, addresses many of these concerns with data and measurements in his paper “Planning Antenna Systems for the Little Gun Station.” Limits on the space available for “antenna farms” also present challenges to the station builder, as discussed by Jim in “Wire Antennas for Limited Space.” Both papers are available online at k9yc.com/publish.htm.

be evaluated in free space or above ground with a wide variety of electrical characteristics.

There are a number of tutorials on using *EZNEC* and *4nec2*. Some are listed on the software's main web page. An internet search will turn up videos on how to use and apply these programs. In addition, there are many designs for antennas already created for these programs. If you are just getting started, practicing with one of the simple designs is an excellent way to learn the program and modeling process. The subject of antenna modeling is also discussed in some detail in the *ARRL Antenna Book*.

21.2 Dipoles and the Half-Wave Antenna

A fundamental form of antenna is a wire whose length is half the transmitting wavelength. It is the unit from which many more complex forms of antennas are constructed and is known as a *dipole antenna*. (The name di- meaning *two* and -pole meaning *electrical charge or polarity* comes from the antenna having two distinct regions of electrical polarity as shown in Figure 21.1.) A dipole is resonant when the current and voltage in the antenna are exactly in phase. Even though the magnitudes of current and voltage along the antenna vary as shown in Figure 21.1, the actual RF current and voltage are in phase, and the feed point impedance is entirely resistive at resonance.

The actual length of a resonant $\frac{1}{2} \lambda$ antenna will not be exactly equal to the half wavelength of the radio wave of that frequency in free space, but depends on the thickness of the conductor in relation to the wavelength as shown in Figure 21.3. An additional shortening effect occurs with wire antennas supported by insulators at the ends because of current flow through the capacitance at the wire ends due to the end effect. Interaction with the ground and any nearby conductors also affects the resonant length of the physical antenna.

The following formula is sufficiently accurate for dipoles below 10 MHz at heights of $\frac{1}{8}$ to $\frac{1}{4} \lambda$ and made of common wire sizes. To calculate the length of a half-wave antenna in feet,

$$\text{Length (ft)} = \frac{492 \times 0.95}{f \text{ (MHz)}} = \frac{468}{f \text{ (MHz)}} \quad (3)$$

Example: A half-wave antenna for 7150 kHz (7.15 MHz) is $468/7.15 = 65.5$ feet, or 65 feet 6 inches. This length is from end insulator to end insulator, including the loops of wire through the insulator and the length of wires

that connect to the feed line. The loops and extra connections will add a small amount of electrical length to the antenna, so be prepared to make small adjustments in antenna length before making a final installation.

For antennas at higher frequencies and/or higher above ground, the best approach is to build the initial dipole using a numerator value of 485 to 490. Make temporary connections at the end insulators. Install the antenna and measure its SWR or impedance. Calculate the percentage difference between the desired and measured resonant frequencies. Adjust the antenna's length by the same amount. For example, for a high dipole at 14.150 MHz, start with an antenna that is $490 / 14.150 = 34.63$ feet long. If the antenna's measured frequency of minimum SWR is 14.6 MHz, the antenna is $100 \times 14.6 / 14.150 = 3.2\%$ too long and should be shortened by that amount, removing an equal amount of wire from each side of the antenna.

Above 30 MHz use the following formulas, particularly for antennas constructed from rod or tubing. K is taken from Figure 21.3.

$$\text{Length (ft)} = \frac{492 \times K}{f \text{ (MHz)}} \quad (4A)$$

$$\text{Length (in)} = \frac{5904 \times K}{f \text{ (MHz)}} \quad (4B)$$

Example: Find the length of a half-wave antenna at 50.1 MHz, if the antenna is made of $\frac{1}{2}$ inch-diameter tubing. At 50.1 MHz, a half wavelength in space is

$$\frac{492}{50.1} = 9.82 \text{ ft}$$

The ratio of half wavelength to conductor diameter (changing wavelength to inches) is

$$\frac{(9.82 \text{ ft} \times 12 \text{ in./ft})}{0.5 \text{ in.}} = 235.7$$

From Figure 21.3, $K = 0.945$ for this ratio. The length of the antenna from equation 3 is

$$\frac{492 \times 0.945}{50.1} = 9.28 \text{ ft}$$

or 9 feet 3- $\frac{3}{8}$ inches. The answer is obtained directly in inches by substitution in equation 4B

$$\frac{5904 \times 0.945}{50.1} = 111.4 \text{ in}$$

Regardless of the formula used to calculate the length of the half-wave antenna, the effects of ground and conductive objects within a wavelength or so of the antenna usually make it necessary to adjust the installed length in order to obtain the lowest SWR at the desired frequency. Use of antenna modeling software may provide a more accurate initial length than a single formula.

The value of the SWR indicates the quality of the match between the impedance of the antenna and the feed line. If the lowest SWR obtainable is too high, an impedance-matching network may be used, as described in the **Transmission Lines** chapter. (High SWR may cause modern transmitters with solid-state power amplifiers to reduce power output as a protective measure for the output transistors.)

21.2.1 Radiation Characteristics

The radiation pattern of a dipole antenna in free space is strongest at right angles to the wire as shown in Figure 21.9. In an actual installation, the figure-eight pattern is less directive due to reflections from ground and other conducting surfaces. As the dipole is raised to $\frac{1}{2} \lambda$

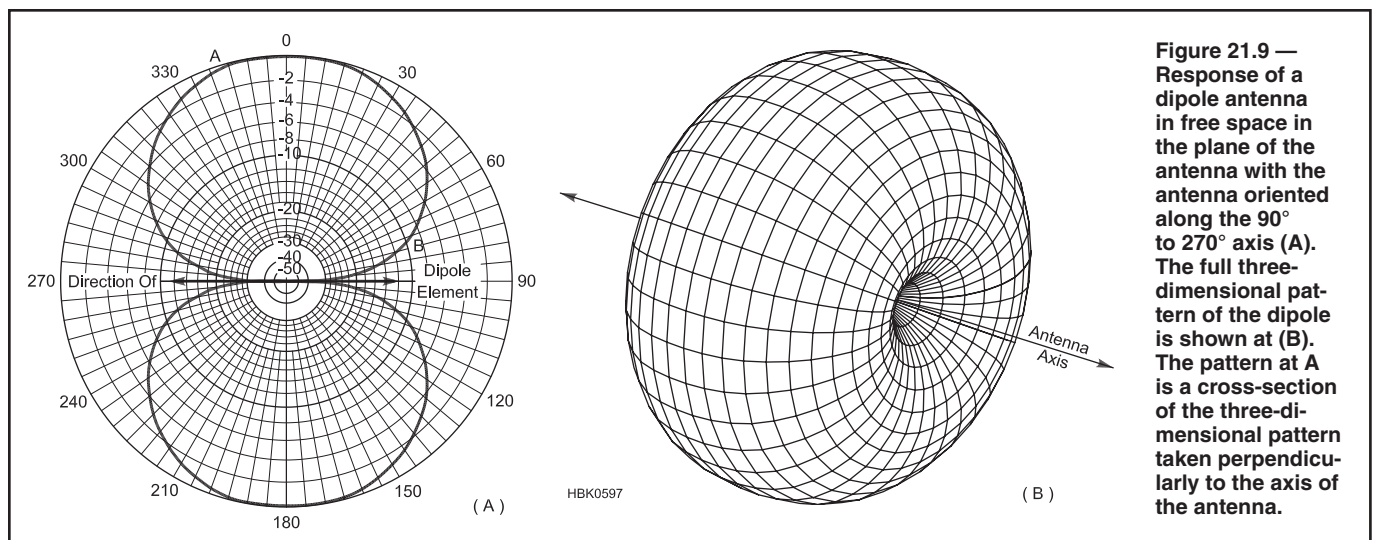

Figure 21.9 — Response of a dipole antenna in free space in the plane of the antenna with the antenna oriented along the 90° to 270° axis (A). The full three-dimensional pattern of the dipole is shown at (B). The pattern at A is a cross-section of the three-dimensional pattern taken perpendicularly to the axis of the antenna.

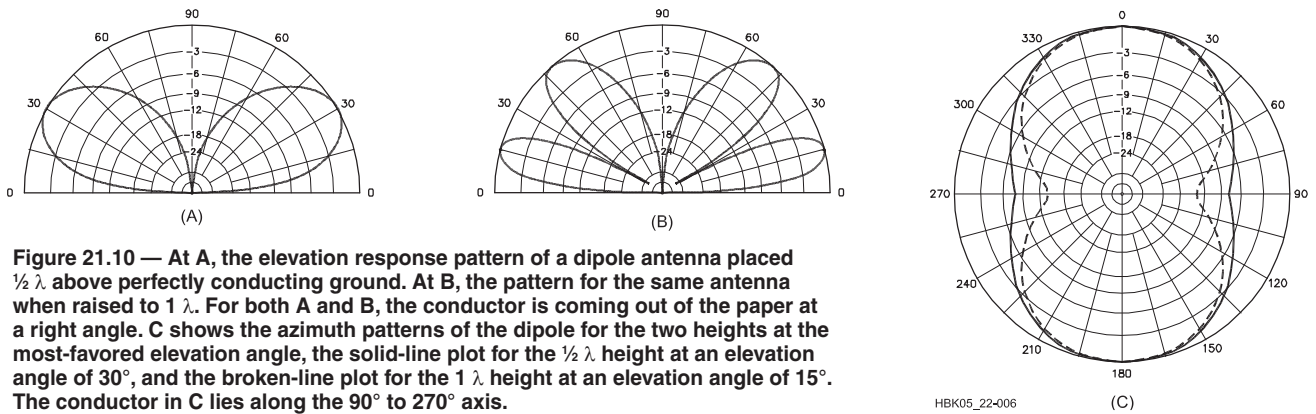
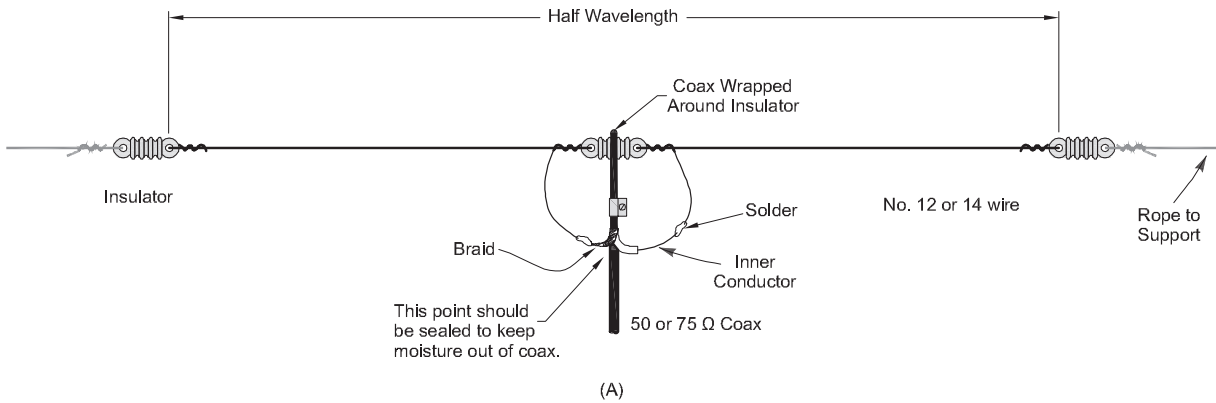

Figure 21.10 — At A, the elevation response pattern of a dipole antenna placed $\frac{1}{2}\lambda$ above perfectly conducting ground. At B, the pattern for the same antenna when raised to 1λ . For both A and B, the conductor is coming out of the paper at a right angle. C shows the azimuth patterns of the dipole for the two heights at the most-favored elevation angle, the solid-line plot for the $\frac{1}{2}\lambda$ height at an elevation angle of 30°, and the broken-line plot for the 1λ height at an elevation angle of 15°. The conductor in C lies along the 90° to 270° axis.

HBK05_22-006

(C)



(A)

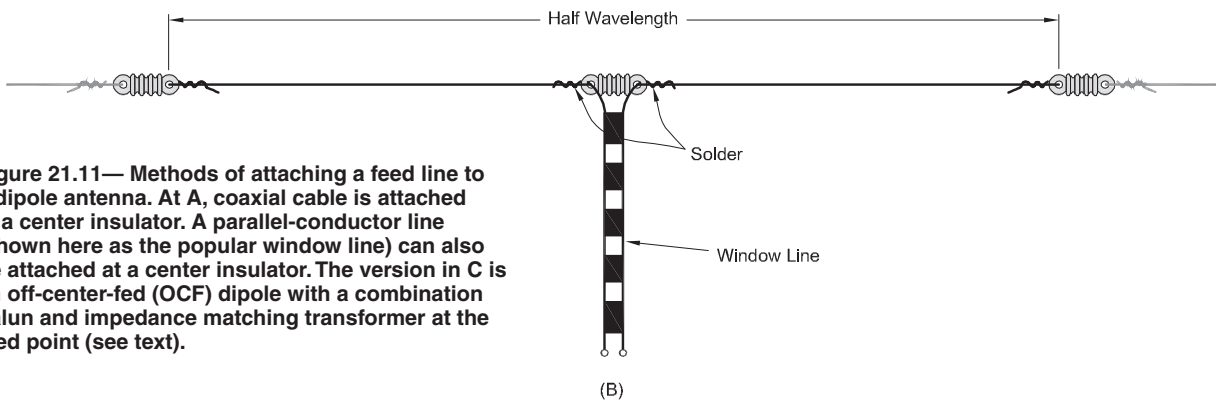

(B)

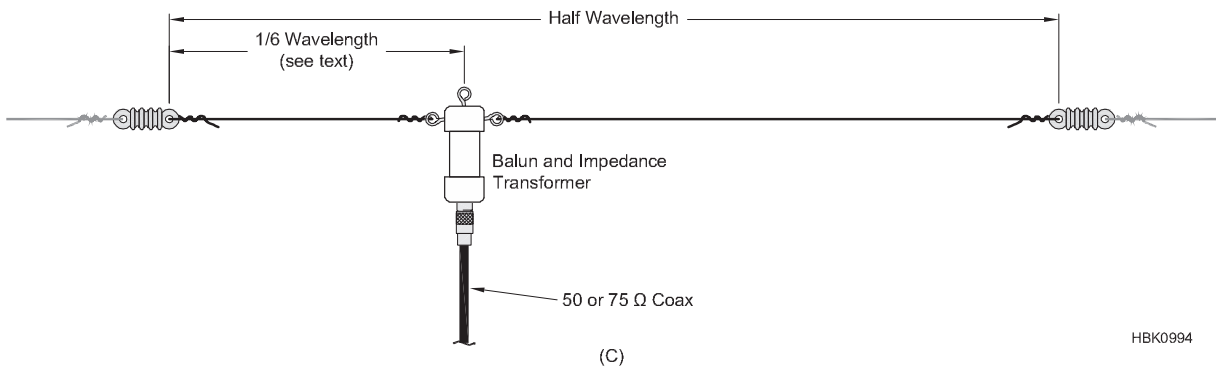

(C)

HBK0994

or greater above ground, nulls off the ends of the dipole become more pronounced. Sloping the antenna and coupling to the feed line tend to distort the pattern somewhat.

As a horizontal antenna is brought closer to ground, the elevation pattern peaks at a higher elevation angle as shown in Figure 21.7. **Figure 21.10** illustrates what happens to the directional pattern as antenna height changes. Figure 21.10C shows that there is significant radiation off the ends of a low horizontal dipole. For the $\frac{1}{2} \lambda$ height (solid line), the radiation off the ends is only 7.6 dB lower than that in the broadside direction.

Figure 21.10 also shows that for short-range communication that depends on high vertical angles of radiation (NVIS communications), a dipole can be too high. For these applications, the dipole should be installed at about 0.2λ so that the antenna radiates strongly at high vertical angles and with little horizontal directivity.

21.2.2 Feed Methods

A feed line is attached directly to the dipole, generally at the center, where an insulator separates the antenna's conductor into two sections or "legs." This is the antenna's *feed point*. One conductor of the feed line is attached to each leg. **Figures 21.11A** and **21.11B** show how the two types of feed lines are attached. There are numerous variations, of course

The low feed point impedance of the half-wave dipole at its resonant frequency, f_0 , and odd harmonics results in a low SWR when fed with coaxial cable. The feed point impedance and resulting SWR with coaxial cable or "coax" will be high at even harmonics and other frequencies.

When fed with ladder line and a wide-range impedance-matching unit, a center-fed antenna can be used on nearly any frequency, including non-resonant frequencies. (An example of such an antenna system is presented as a project farther along in this section.) Another variation, shown in Figure 21.11B, is the *Zepp* (or *end-fed half wave, EFHW*), named for its original application as an antenna deployed from Zeppelin airships. The feed point impedance of a "Zepp" is quite high, requiring impedance matching to deliver power effectively.

The EFHW has become popular for portable, low-power operation since it can be temporarily installed with only one support and a short coax feed line from an impedance-matching transformer at the feed point. The EFHW can also be used as a variation of the *random-wire antenna*, where it is attached directly to the output of the transmitter as described later in this chapter.

A dipole can be fed anywhere along its length, although the impedance of the antenna will vary as discussed earlier. One common variation is the *off-center-fed (OCF)* dipole (Figure 21.11C), where the feed point is offset from center by some amount and an impedance transformer matches the resulting moderately high impedance to that of coaxial cable. The impedance transformer is usually paired with a choke balun to decouple the feed line, as described in the next section. The OCF can also be fed with open-wire line. OCF dipoles are further discussed later in this chapter.

21.2.3 Feed Point Baluns

Open-wire transmission lines and center-fed dipole antennas are *balanced*, that is, each conductor or section has the same impedance to the system reference, usually Earth ground. This is different from *unbalanced* coaxial cable, in which the shield is generally connected to an Earth ground at some point, generally at the transmitter. To use balanced open-wire transmission lines with unbalanced equipment — most amateur equipment is unbalanced — a *balun* is required to make the transition between the balanced and unbalanced parts of the antenna system. "Balun" is an abbreviation of "balanced-to-unbalanced," the function of the device — it allows power to be transferred between the balanced and unbalanced portions of an antenna system in either direction. The most common application of baluns is to connect an unbalanced feed line to a balanced antenna. (Baluns and the related *ununs* are discussed in the **Transmission Lines** chapter.) Because dipoles are balanced, a balun is often used at the feed point when a dipole is fed with coax.

Due to the skin effect discussed in the **RF Techniques** chapter, the inside and outside of the coaxial cable shield act as separate conductors at RF. This "third conductor" of a coaxial

cable unbalances the symmetry of the dipole antenna when the coax is connected directly to the dipole, as shown in Figure 21.11A. As a result, RF current can flow on the outside of the cable shield to the enclosures of station equipment connected to the cable. This combination of the dipole and feed line shield is likely to have a different resonant frequency and feed point impedance than what was intended.

In order to *decouple* the coax shield from the antenna, a *choke* or *current balun* is recommended as shown in **Figure 21.12**. The choke balun creates a high impedance on the outside of the coax shield while leaving currents inside the coax unaffected. See the **Transmission Lines** chapter for choke balun designs.

Shield currents can also impair the function of instruments connected to the line (such as SWR meters and SWR-protection circuits in the transmitter). The shield current also produces some feed line radiation, which changes the antenna radiation pattern and allows objects near the cable to affect the antenna-system performance.

The consequences may be negligible: A slight skewing of the antenna pattern usually goes unnoticed. Or, they may be significant: False SWR readings may cause the transmitter to reduce power unnecessarily; radiating coax near a TV feed line may cause strong local interference from overload. Therefore, it is better to eliminate feed line radiation whenever possible, and a choke balun should be used at any transition between balanced and unbalanced systems. Even so, balanced or unbalanced systems without a balun often operate with no apparent problems. For temporary or emergency stations, do not let the lack of a balun deter you from operating.

21.2.4 Building Dipoles and Other Wire Antennas

The purpose of this section is to offer information on the actual physical construction of wire antennas. Because the dipole, in one of its configurations, is probably the most common amateur wire antenna, it is used in the following examples. The techniques described here, however, enhance the reliability and safety of all wire antennas.

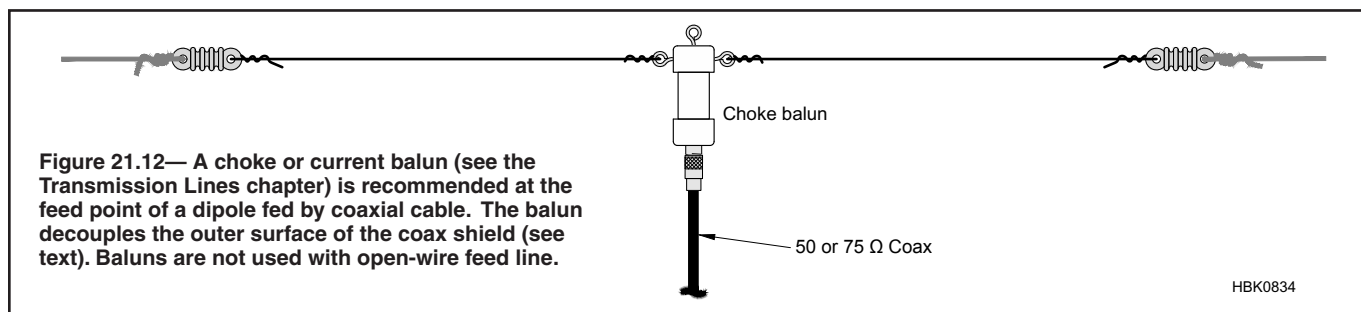

Figure 21.12— A choke or current balun (see the **Transmission Lines** chapter) is recommended at the feed point of a dipole fed by coaxial cable. The balun decouples the outer surface of the coax shield (see text). Baluns are not used with open-wire feed line.

HBK0834

WIRE

Choosing the right type of wire for the project at hand is the key to a successful antenna — the kind that works well and stays up through a winter ice storm or a gusty spring wind storm. What gauge of wire to use is the first question to settle; the answer depends on strength, ease of handling, cost, availability, and visibility. Generally, antennas that are expected to support their own weight plus the weight of the feed line should be made from #12AWG or larger wire. (The National Electrical Code [NEC] specifies a minimum size of #10 AWG for external antennas.) Horizontal dipoles, Zepps, some long wires, and the like fall into this category. Antennas supported in the center, such as inverted-V dipoles and delta loops, may be made from lighter material such as #14 AWG wire.

The type of wire to be used is the next important decision. The wire specifications table at the end of this chapter shows popular wire styles and sizes. The strongest wire suitable for antenna service is *copper-clad steel*, also known as *copperweld*. The copper coating is necessary for RF service because steel is a relatively poor conductor. Practically all of the RF current is confined to the copper coating because of skin effect. Copper-clad steel is outstanding for permanent installations, but it can be difficult to work with because of the stiffness of the steel core. Kinks, abrasion, or repeated flexing can crack the copper cladding, leading to rusting of the inner steel core. Damage to the cladding can result in increased resistance and loss. Rusting of the inner core will eventually weaken the antenna. Regularly inspecting the antenna visually or checking SWR for changes can help spot problems.

Solid-copper wire, either hard-drawn or soft-drawn, is another popular material. Easier to handle than copper-clad steel, solid copper is available in a wide range of sizes. It is generally more expensive however, because it is all copper. Soft-drawn stretches under tension, so periodic pruning of the antenna may be necessary in some cases. Enamel-coated *magnet-wire* is a suitable choice for experimental antennas

because it is easy to manage, and the coating protects the wire from the weather. Although it stretches under tension, the wire may be pre-stretched before final installation and adjustment. A local electric motor rebuilder might be a good source for magnet wire.

Hook-up wire, speaker wire, or even ac lamp cord are suitable for temporary installations. Almost any copper wire may be used, as long as it is strong enough for the demands of the installation.

Aluminum wire can be used for antennas, but is not as strong as copper or steel for the same diameter, and soldering it to feed lines requires special techniques. Galvanized and steel wire, such as that used for electric fences, is inexpensive, but it is a much poorer conductor at RF than copper and should be avoided.

Kinking, which severely weakens wire, is a potential problem when handling any solid conductor. When uncoiling solid wire of any type — copper, steel, or aluminum — take care to unroll the wire or untangle it without pulling on a kink to straighten it. A kink is actually a very sharp twist in the wire and the wire will break at such a twist when flexed, such as from vibration in the wind.

Solid wire also tends to fail at connection or attachment points at which part of the wire is rigidly clamped. The repeated flexing from wind and other vibrations eventually causes metal fatigue and the wire breaks. Stranded wire is preferred for antennas that will be subjected to a lot of vibration and flexing. If stranded wire is not suitable, use a heavier gauge of solid wire to compensate.

Insulated vs Bare Wire

Losses are the same (in the HF region at least) whether the antenna wire is insulated or bare. If insulated wire is used, a 3 to 5% shortening from the length calculated for a bare wire is required to obtain resonance at the desired frequency. This is caused by the increased distributed capacitance resulting from the higher dielectric constant of the plastic insulating material compared to air. The actual length for resonance must be determined experimentally by pruning and measuring be-

cause the dielectric constant of the insulating material varies from wire to wire. Wires that might come into contact with humans or animals should be insulated to reduce the chance of shock or burns.

INSULATORS

Wire antennas must be insulated at the ends and usually at the feed point. Commercially available insulators are made from ceramic, glass, or plastic. Insulators are available from many amateur radio dealers. Local hardware and farm stores are other possible sources of insulators for electric fences. Ceramic or glass insulators will usually outlast the wire, so they are highly recommended for a safe, reliable, permanent installation. **Figure 21.13C** shows the proper way to attach a wire to a strain or “egg” insulator. **Figures 21.13A** and **21.13B** show examples of center insulators. **Figure 21.13A** is popularly known as a “dog bone” insulator and is available in glass, ceramic, and plastic. The ridges prevent water or dust from forming a conductive path across the insulator. **Figure 21.13B** shows a Budwig HQ-1 insulator with a built-in SO-239 and wires for attaching to the antenna. Acceptable homemade insulators may be made from a variety of material including (but not limited to) polycarbonate sheet or rod, PVC tubing or plumbing fixtures, or fiberglass rod. Temporary or emergency antennas can even make use of stiff plastic from a discarded container or dry wood. **Figures 21.14A** and **21.14B** show some homemade insulators. If you make your own insulators, be sure the material is sturdy enough to withstand the mechanical stress and is UV-resistant to be suitable for prolonged outdoor use.

ATTACHING FEED LINES

Most wire antennas require an insulator at the feed point. Although there are many ways to connect the feed line, there are a few things to keep in mind. If you feed your antenna with coaxial cable, you have two choices. You can install an SO-239 connector on the center insulator and use a PL-259 on the end of your coax, or you can separate the center conductor from the braid, creating a pigtail connection,

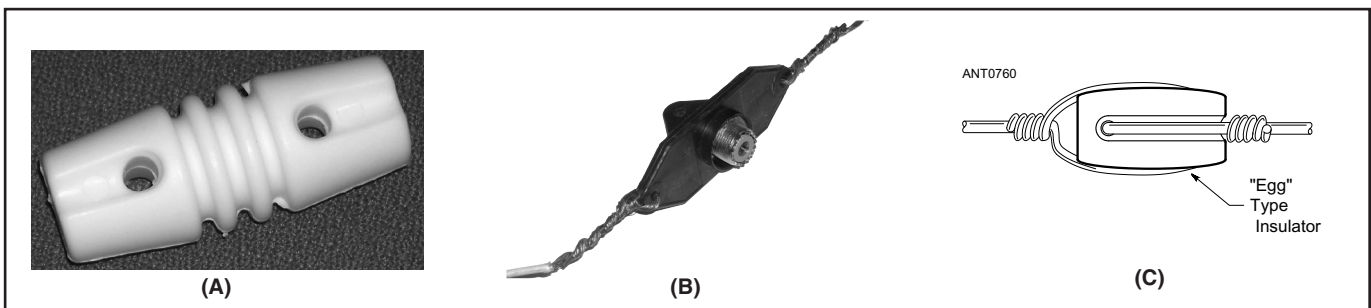

Figure 21.13 — (A) and (B) show examples of commercial center insulators: a dog-bone insulator and a Budwig HQ-1 insulator. (C) The correct way to attach a wire to a strain or “egg” insulator.

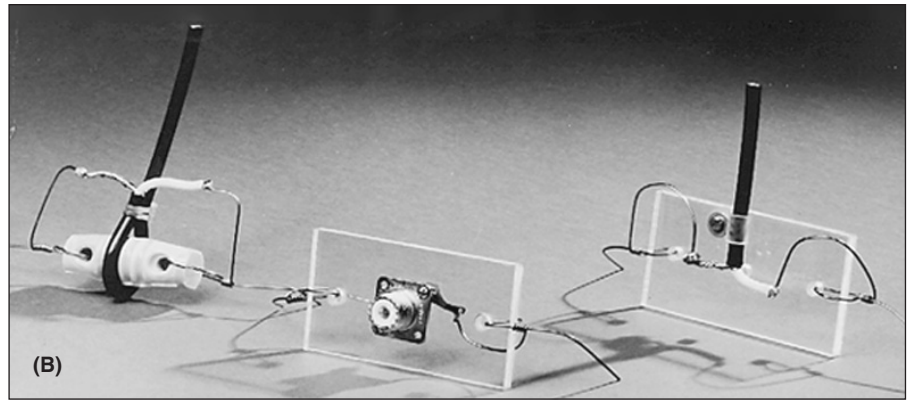
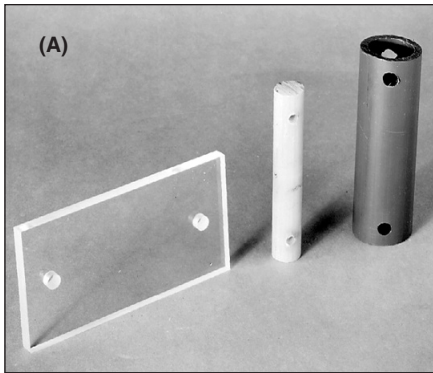

Figure 21.14 — (A) Some ideas for homemade antenna insulators. (B) Some homemade dipole center insulators. The one in the center includes a built-in SO-239 connector. Others are designed for direct connection to the feed line. Be sure to use UV-resistant plastic for insulators.

and attach the feed line directly to the antenna wire. Although it costs less to connect directly to the antenna, the use of connectors offers several advantages. (See the **Transmission Lines** chapter for more information about selecting and installing feed lines.)

Coaxial cable braid acts as a wick to soak up water. If you do not adequately seal the antenna end of the feed line, water will find its way into the braid. Water in the feed line will contaminate the braid, causing high losses and rendering the coax useless long before its normal lifetime is up. It is not uncommon for water to drip from the end of the coax inside the station after a year or so of service if the antenna connection is not properly waterproofed. Use of a PL-259/SO-239 combination (or other connector of your choice) makes the task of waterproofing connections much easier. Another advantage to using the PL-259/SO-239 combination is that feed line replacement is much easier, should that become necessary or desirable.

Whether you use coaxial cable, ladder line, or twin lead to feed your antenna, an often-overlooked consideration is the mechanical strength of the connection. Wire antennas and feed lines tend to move a lot in the wind, and unless the feed line is attached securely, the connection will weaken with time. The resulting failure can range from a frustrating intermittent electrical connection to a complete separation of feed line and antenna. Figure 21.14B illustrates several different ways of attaching the feed line to the antenna. An idea for supporting ladder line is shown in **Figure 21.15**.

PUTTING IT TOGETHER

If made from the right materials and installed in the clear, the dipole should give years of maintenance-free service. As you build your antenna, keep in mind that if you get it right the first time, you won't have to do it again for a long time.

Figure 21.11 shows details of antenna con-

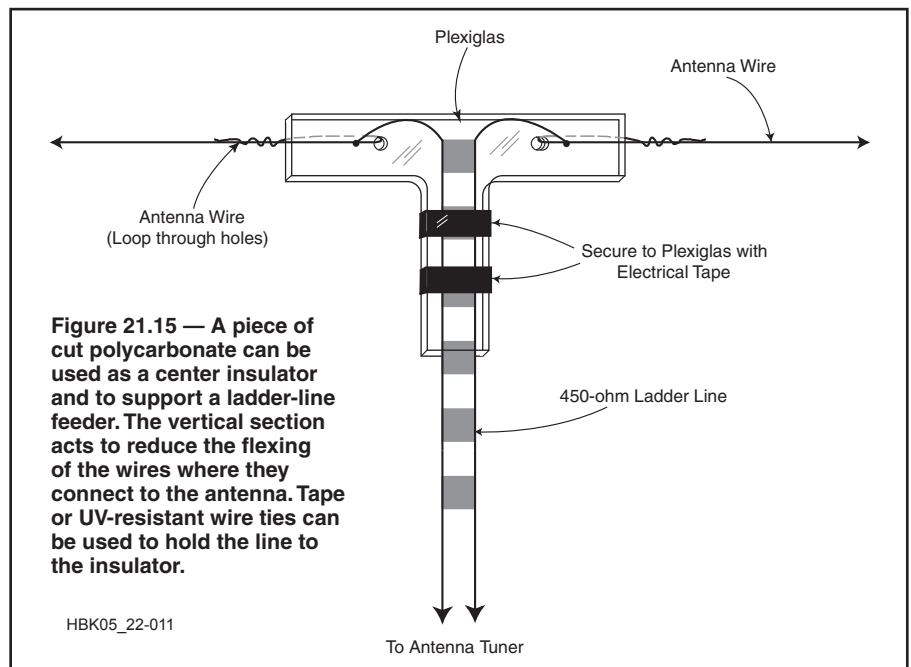

struction. Although a dipole is used for the examples, the techniques illustrated here apply to any type of wire antenna. **Table 21.1** shows dipole lengths for the amateur HF bands. These lengths do not include the extra wire required to attach the wire to the insulator as shown in Figure 21.11. Determine the extra amount of wire required by experimenting with the insulator you intend to use. Add twice this amount of wire to the leg lengths in Table 21.1, one extra length for each insulator. (Four such attachments are required for each dipole — two on each leg.)

Most dipoles require a little pruning to reach the desired resonant frequency due to the effects of ground and nearby conducting objects and surfaces. (See the beginning of this section for an explanation.) Table 21.1 includes lengths based on the classic $468/f$ formula and on $490/f$ intended to be a starting

length. Record the constructed length with all insulators attached. (The constructed length is measured between the ends of the loops at each end of the wire and includes the length of any feed line-to-antenna connections.) Next, raise the dipole to the working height and find the frequency at which minimum SWR occurs. Multiply the frequency of the SWR minimum by the antenna length and divide the result by the desired f_0 . The result is the finished length; trim both ends equally to reach that length and you're done. For example, if you want the SWR minimum to occur at 14.1 MHz and the first attempt with a constructed length of 33.8 feet results in an SWR minimum at 13.9 MHz, the final length for the antenna is

$$33.8 \times (13.9/14.1) = 33.3 \text{ ft}$$

In determining how well your antenna will work over the long term, how well you put the

Table 21.1**Dipole Dimensions for Amateur Bands***Table A – Dipole Lengths based on 468/f*

Freq (MHz)	-----Overall Length -----			----- Leg Length -----		
	ft	in	m	ft	in	m
1.82	257	2	78.4	128	7	39.2
3.6	130	0	39.7	65	0	19.8
5.378	7	2	43.6	43	7	21.8
7.1	65	10	20.1	32	11	10.05
10.1	46	4	14.13	23	2	7.06
14.1	33	2	10.12	16	7	5.06
18.1	25	10	7.89	12	11	3.94
21.1	22	2	6.76	11	1	3.38
24.9	18	9½	5.73	9	4¾	2.87
28.4	16	6	5.03	8	3	2.51

Table B – Dipole Lengths based on 490/f

Freq (MHz)	-----Overall Length -----			----- Leg Length -----		
	ft	in	m	ft	in	m
1.82	269	3	82.1	134	7	41.1
3.6	136	1	41.5	66	1	20.8
5.37	91	3	27.8	45	7	13.9
7.1	69	0	21.0	34	6	10.5
10.1	48	6	14.8	24	3	7.4
14.1	34	9	10.6	17	5	5.3
18.1	27	1	8.26	13	6½	4.13
21.1	23	2½	7.08	11	7¼	3.54
24.9	19	8	6.00	9	10	3.00
28.4	17	3	5.26	8	7½	2.63

pieces together is second only to the ultimate strength of the materials used. Even the smallest details, such as how you connect the wire to the insulators, contribute significantly to antenna longevity. Where wires are soldered, use only enough heat to make a good connection. Excessive heat, such as from a propane torch, can anneal the wire, weakening it at the solder point.

By using plenty of wire at the end insulators and wrapping it tightly, you will decrease the possibility of the wire pulling loose in the wind. There is no need to solder the wire once it is wrapped. There is no electrical connection here, only mechanical.

Similarly, the feed line connection at the center insulator should be made to the antenna wires after they have been secured to the insulator. This way, you will be assured of a good electrical connection between the antenna and feed line without compromising the mechanical strength. Do a good job of soldering the antenna and feed line connections. Use a heavy iron or a soldering gun (200 W is a good size to use for this job), and be sure to clean the materials thoroughly before starting the job. If possible, solder the connections at a workbench, where the best possible joints may be made. Poorly soldered or unsoldered connections will become headaches as the wire oxidizes and the electrical integrity degrades with time. Besides degrading your antenna performance, poorly made joints can even be a cause of TVI because of rectification. Spray

the connections with a UV-resistant acrylic coating or use a brush-on insulation coating for waterproofing.

NON-SOLDERED ATTACHMENTS

There are other options than soldering for securing wires to insulators and attaching feed lines, particularly parallel conductor lines. You can use crimping or clamping connectors as well as waterproof terminals. As with soldered connections, some form of mechanical strain relief will be necessary to prevent repeated flexing from breaking the wires at the connection.

Split-bolt connectors used for grounding conductors can be used to hold large wires together. (Search for “split-bolt” at www.grainger.com.) They are available in bronze and copper alloys (for copper-copper connections). The smallest standard sizes such as Burndy KS90 accept up to #8 AWG wires and can be used to clamp combinations of smaller wires down to #16 AWG. These connectors are not waterproof, so coat all of the conductors with a contact protective compound intended for outdoor use. Sleeve-style crimp connectors can also be used with the same caution about using an outdoor-listed protective compound.

For lighter duty and temporary connections, Anderson Powerpole and quick-disconnect crimp terminals are good choices. You must solder or crimp the wires into the terminals. These non-locking connections will pull apart under tension, so some strain relief is neces-

sary. Both types of connectors can be waterproofed with a heat-shrink or other protective sleeve.

ATTACHING ANTENNA SUPPORTS

If towers, masts, or buildings are available, attaching the antenna support ropes or cables is fairly straightforward. Pulleys or guides such as stainless steel or aluminum carabiners or large screw eyes rated for the expected load should be used. Counterweights or springs can be used to allow the antenna to move in the wind.

Trees are a time-honored and very common solution to holding the antenna up in the air. They present some difficulties in attaching the support rope or cable, however. The most important consideration is safety. Any time a tree support is being considered, take care to ensure that there are no power lines at any voltage in or near the tree. The lines are not always easily visible. If a weight is propelled over or through the tree, it may fly well beyond the tree and cause the trailing line to contact power lines that way. In any case, don't become a statistic! Check the entire area around the tree for hazards.

If you can climb the tree and attach the support hardware, the main problem involves providing enough tension and flexibility to allow the supports to move with the tree during wind and storms. Climbing or hiring a tree climber can pay benefits over the long term with tree-supported antennas, since a pulley and halyard can be securely attached to the tree. (More information on tree-mounting antennas can be found in the *ARRL Antenna Book*.)

If climbing is not an option, such as for a temporary or portable station or for trees not suitable for climbing, getting a line into the tree is a challenge. Hams have devised many different methods of getting a line over a branch, from the “Armstrong method” (throwing a weight such as an arborist's weight bag or a tennis ball throwing toy), to various fishing techniques, and even archery. Two very popular current methods are the slingshot and the compressed-air “spud gun.” Both launch a small projectile attached to lightweight monofilament fishing line through or over a tree. (Hint — paint the projectile a bright color so it's easy to find in brush or long grass.) That line is used to pull a length of twine or string over the branch and then the rope or cable that forms the final support. (The *QST* article “The W4SSY Spudgun” is available in this book's online content and several vendors offer commercial versions of the compressed-air or slingshot launcher.)

Another option is the use of an RPV (remotely piloted vehicle), better known as a “drone.” The lightest line is attached to the drone, which is then piloted over the tree and back to the ground where the next line is attached, as with the launcher or slingshot. Drones can rarely be

Wide-Band Dipoles for 80 and 75 Meters

Amateur radio's widest HF band (about 13%), the 80 – 75-meter band can vex the station builder limited to a single wire antenna. Several approaches have been shown to work without extraordinary tricks. These range from increasing the conductor size (cage dipoles), to parallel elements (fan dipole and coupled resonators), and transmission line transformers. Several articles are included in this book's online information to provide options that may be suitable for your needs and circumstances:

"Broad-Band 80-Meter Antenna," by Allen Harbach WA4DRU (*QST*, Dec. 1980)

"A Simple Broadband Dipole for 80 Meters," by Frank Witt AI1H (*QST*, Sep. 1993)

"A Wideband 80-Meter Dipole," by Rudy Severns N6LF (*QST*, July 1995)

"The Fan Dipole as a Wideband and Multiband Antenna Element," by Joel Hallas W1ZR (*QST*, May 2005)

The ARRL Antenna Book chapter on Single-Band MF and HF Antennas goes into detail about several techniques with example designs. Finally, the article "The Story of the Broadband Dipole," by Dave Leeson W6NL (*QEX*, Nov 2018) includes a list of references for the truly interested reader to learn about solutions to one of ham radio's longest-running challenges.

flown *through* a tree, limiting line placement to the uppermost branches. This results in the highest possible support point but the branches are the smallest on the tree.

If you use a pulley, select a size that prevents the rope from slipping between the sheave and housing as the antenna and ropes move in the wind. So that the antenna stays up after installation, keep it away from tree branches and other objects that might rub or fall on the antenna. If the supports for the antenna, such as trees, move in the wind, leave enough slack in the antenna that it is not pulled overly tight in normal winds. Other options are to use pulleys and counterweights to allow the antenna supports to flex without pulling on the antenna. (This and other installation topics are covered in the *ARRL Antenna Book*.)

For long spans or heavy wire antennas, it may be necessary to know the expected amount of sag across the span. There are on-line cable sag calculators, such as at www.easycalculation.com/analytical/cable-sag-error.php. You will need to know the weight per unit length of the wire (and rope, if significant), the span to be covered, and the weight of feed line attached to the antenna.

You can experiment with the tension on the support ropes to get the desired sag or enter the desired tension and calculate the resulting sag. The tables Copper Wire Specifications and Antenna Wire Strength at the end of this chapter will be useful.

ANTENNA SUPPORT ROPE

A good rope for holding up wire antennas with spans up to 150 or 200 feet is $\frac{1}{4}$ -inch nylon rope, UV-resistant $\frac{5}{32}$ - or $\frac{3}{16}$ -inch Dacron rope is also popular. After an installation with any new rope, it will be necessary to repeatedly take up the slack created by stretching. This process will continue over a period of several weeks, at which time most of the stretching will have taken place. Even a year after installation, however, some slack may still arise from stretching.

Make certain that the rope ends will not unravel. Most supply stores will cut the length with a hot knife; that will do the best job of sealing the ends. You can do it at home by simply melting the ends with a match or cigarette lighter. An alternative is to tightly wrap a few layers of electrical tape or heat shrink tubing around the ends. Be sure to tape the ends of all your ropes to protect them.

21.2.5 Bent Dipoles

Dipole antennas need not be installed in a straight horizontal line. They are generally tolerant of bending, sloping or drooping. Bent dipoles may be used where antenna space is at a premium. **Figure 21.16** shows a couple of possibilities; there are many more. Bending distorts the radiation pattern somewhat and may affect the impedance as well, but compromises may be acceptable when the situation demands them. When an antenna bends back on itself (as in **Figure 21.16B**) some of the signal is canceled; avoid this if possible. Remember that the ends of the dipole are high-voltage points. Keep them away from conductors, flammable materials, and where they can be accidentally touched.

21.2.6 Inverted-V Dipole

An *inverted-V* dipole shown in **Figure 21.16C** is supported at the center with a single support, such as a tree or mast. While *V* describes the shape of this antenna, it should not be confused with long-wire horizontal-*V* antennas, which are highly directive.

The inverted-*V*'s radiation pattern and feed point impedance depend on the *apex angle* between the legs: As the apex angle decreases, so does feed point impedance, and the radiation pattern becomes less directive. At apex angles below 90° , the antenna efficiency begins to decrease as well.

The proximity of ground to the antenna ends will lower the resonant frequency of the an-

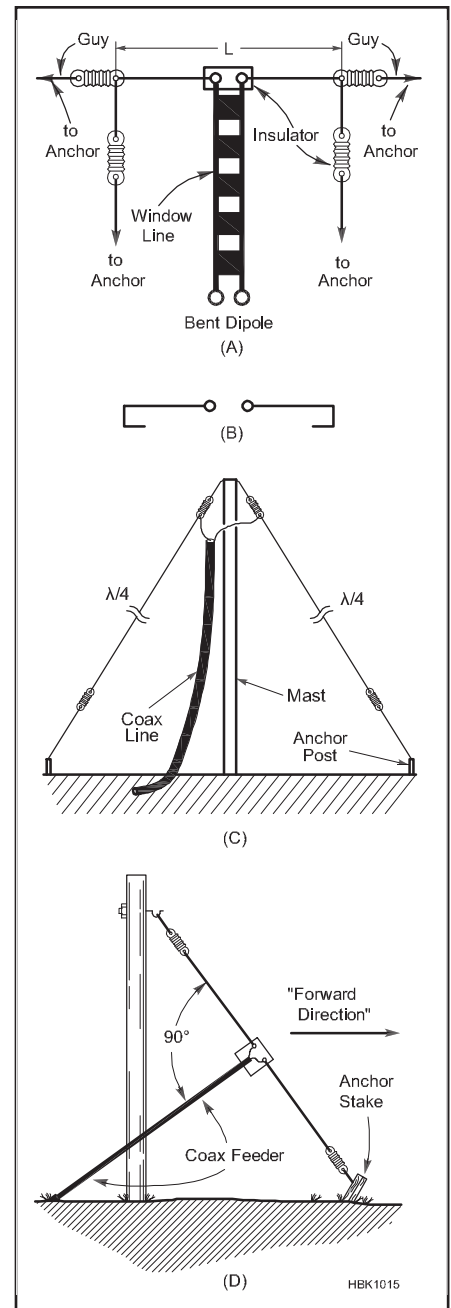

Figure 21.16 — When limited space is available for a dipole antenna, the ends can be bent downward as shown at A, or back on the radiator as shown at B. The inverted-*V* at C can be erected with the ends bent parallel with the ground when the available supporting structure is not high enough. At D is an example of a sloping $\frac{1}{2} \lambda$ dipole, or *full sloper*.

tenna so that a dipole may have to be shortened in the inverted-*V* configuration. Losses in the ground increase when the antenna ends are close to the ground. Keeping the ends eight feet or higher above ground reduces ground loss and also prevents accidental contact with the antenna.

Remember that antenna current produces the radiated signal, and current is maximum at the dipole center. Therefore, performance is best when the central area of the antenna is high and clear of nearby objects.

21.2.7 Sloping Dipole

A sloping dipole is shown in Figure 21.16D. This antenna is often used to favor one direction (the *forward direction* in the figure). With a non-conducting support and poor ground, signals off the back are somewhat weaker than those off the front. With a non-conducting mast and good ground, the response is approximately omnidirectional.

A conductive support such as a tower can act as a parasitic element. (So does the coax shield, unless it is routed at 90° from the antenna or decoupled with a choke balun.) The parasitic effects vary with ground quality, support height, and other conductors on the support (such as a beam at the top or other wire antennas). With such variables, performance is very difficult to predict, although modeling may give some insight into how the antenna will perform.

Losses increase as the antenna ends approach the support or the ground since the antenna ends are high-voltage points, the same cautions about their height apply as for the inverted-V antenna. To minimize feed line coupling and radiation, route the coax away from the feed point at 90° from the antenna as far as possible or use a choke balun.

21.2.8 End-Fed Half-Wave (EFHW)

Figure 21.17 shows the EFHW antenna, a half-wavelength dipole fed at one end. The open end is supported by a tree, mast, or other convenient attachment point and the feed point can be close to the ground or elevated. The EFHW is popular for portable and temporary operation in the sloping configuration shown. It can also be installed horizontally with the feed point elevated. Both ends of the antenna will be high voltage points and should be kept clear of tree branches and leaves, and away from where they can be touched accidentally.

The EFHW can be used on any band for which it is an integer number of half-wavelengths long. It may also present an acceptable impedance on non-resonant bands. For example, an EFHW for 80 meters will also be useable on 40, 20, 15, and 10 meters, as well as 30, 17, and 12 meters with a somewhat higher SWR.

The feed point's high impedance must be transformed to a lower value so that coaxial feed line can be used. A 49:1 impedance transformer (7:1 turns ratio) as shown in Figure 21.18 is a popular choice, although 9:1 and 16:1 ratios may work acceptably. Placing the

feed point a few feet from one end will also lower the impedance somewhat.

The EFHW requires a counterpoise to stabilize the feed point impedance. The outer surface of the coaxial feed line often serves as the counterpoise, so do not use a feed point choke balun without a counterpoise wire. If it is necessary to reduce common-mode RF current on the feed line, a choke balun or "line isolator" can be added 10 feet or more from the feed point, or where the feed line reaches ground level if the feed point is elevated. In the common configuration with the feed point near the ground, a few feet of wire connected to the feed line shield will supplement the feed line shield in stabilizing the feed point impedance. If installed with the feed point elevated, the feed line shield serves as a counterpoise and a separate wire is not used. A ground rod is not necessary.

The EFHW antenna is explained in more detail in a presentation from Steve Dick, K1RF, at gnarc.org/wp-content/uploads/The-End-Fed-Half-Wave-Antenna.pdf and on the website of Steve Yates, AA5TB, at www.aa5tb.com/efha.html.

21.2.9 Inductively Loaded Dipoles

Inductive loading increases the electrical length of a conductor without increasing its physical length. Therefore, we can build physically short dipole antennas by placing inductors in the antenna. These are called *loaded dipoles*, and *The ARRL Antenna Book* includes information on how to design them. There are some trade-offs involved: Inductively loaded antennas are less efficient and have narrower bandwidths than full-size antennas. Generally they should not be shortened more than 50%. David Birnbaum, K2LYV, explains the process of designing loaded dipoles that work on two bands in an article contained in this book's online information.

21.2.10 Folded Dipoles

Figure 21.19 shows a *folded dipole* constructed from open-wire transmission line. The dipole is made from a $\frac{1}{2} \lambda$ section of open-wire line with the two conductors connected together at each end of the antenna. The top

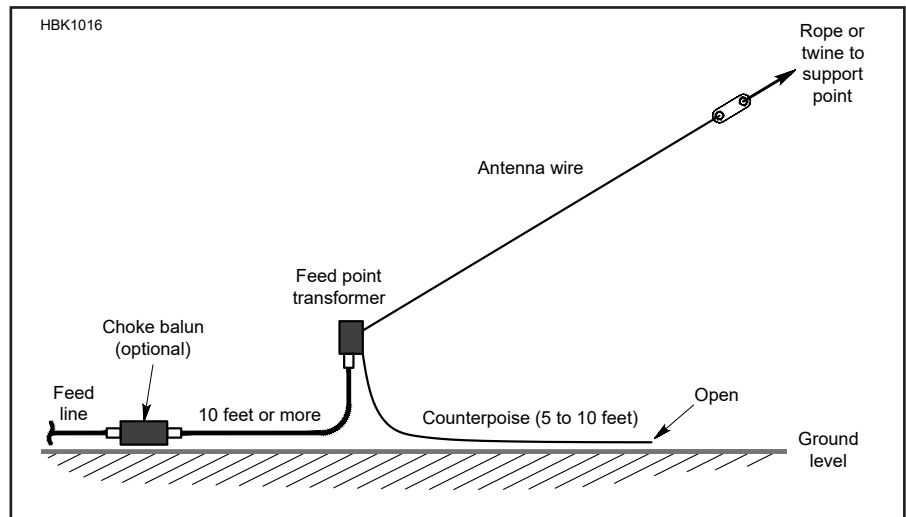

Figure 21.17 — The end-fed half-wave (EFHW) antenna. For permanent use, it can be installed horizontally with both ends well above ground. For portable or temporary use, it is common to keep the feed point near ground level and support the other end with a multi-section fiberglass mast or with a rope over a tree branch.

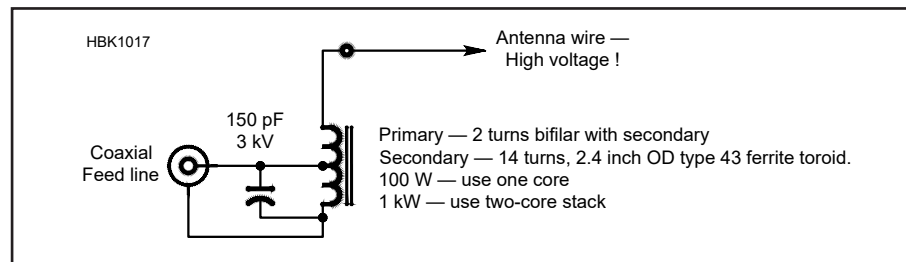

Figure 21.18 — A common 49:1 impedance transformer design. The transformer consists of a 2-turn primary and 14-turn secondary. The primary and first two secondary turns are bifilar. The 150 pF capacitor compensates for transformer inductance above 20 MHz. A low-loss 3 kV ceramic capacitor is recommended.

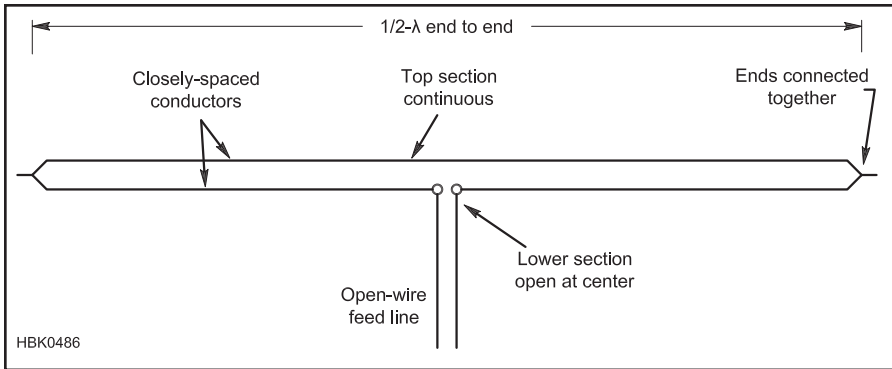

Figure 21.19 — The folded dipole is constructed from open-wire transmission line with the ends connected together. The close proximity of the two conductors and the resulting coupling act as an impedance transformer to raise the feed point impedance over that of a single-wire dipole by the square of the number of conductors used.

conductor of the open-wire length is continuous from end to end. The lower conductor, however, is cut in the middle and the feed line, attached at that point. Open-wire transmission line is then used to connect the transmitter.

A folded dipole has exactly the same gain and radiation pattern as a single-wire dipole. However, because of the mutual coupling between the upper and lower conductors that divides antenna current equally between the conductors, the feed point impedance of a single-wire dipole is multiplied by the square of the number of conductors in the antenna. In this case, there are two conductors in the antenna, so the feed point impedance is $2^2 = 4$ times that of a single-wire dipole. (A three-wire folded dipole would have a nine times higher feed point impedance and so forth.)

A common use of the folded dipole is to raise the feed point impedance of the antenna to present a better impedance match to a high impedance feed line. For example, if a very long feed line to a dipole is required, open-wire feed line would be used. By raising the dipole's feed point impedance, the SWR on the open-wire line is reduced from that of a single-wire dipole fed with open-wire feed line. Impedance matching to the usual $50\ \Omega$ can then be done at the transmitter.

A variation of the folded dipole called the *twin-folded terminated dipole (TFTD)* adds a resistor in the top conductor. Values of 300 to 600 Ω are used. The function of the resistor is to act as a *swamping* load, reducing the higher feed point impedances over a wide frequency range. A TFTD $\frac{1}{2}\lambda$ long at 80 meters can be constructed to cover the entire 2 to 30 MHz range with SWR of 3:1 or less. The resistor dissipates some of the transmitter power (more than 50% at some frequencies!), but the improvement in SWR allows a coaxial feed line to be used without an impedance-matching unit. The increased convenience and installation outweigh the reduction in radiated signal. TFTD antennas are popular for emergency

communications and where only a single HF antenna can be installed and high performance is not required, such as for regional coverage via NVIS as described below.

21.2.11 Parallel (Fan) Dipoles

Parallel dipoles (also called *fan dipoles*) as shown in **Figure 21.20** are a simple and convenient answer. Center-fed dipoles have low feed point impedance on the fundamental and odd harmonics, and high impedances at other frequencies. This lets us construct simple multiband systems in which the antenna for the desired band is automatically active. Consider a $50\ \Omega$ resistor connected in parallel with a 5 k Ω resistor. A generator connected across the two resistors will see 49.5 Ω , and 99% of the current will flow through the $50\ \Omega$ resistor. When resonant and non-resonant antennas are connected in parallel, the same result occurs: The non-resonant antenna has a high impedance, so little current flows in it and

it has little effect on the total feed point impedance. Thus, we can connect several dipoles together at the feed point, and power naturally flows to the resonant antenna.

There are some limits, however. Wires in close proximity tend to be strongly coupled. In parallel dipoles, this coupling means that the resonant length of the shorter dipoles lengthens by a few percent. Shorter antennas don't affect longer ones much, so adjust for resonance in order from longest to shortest. Coupling also reduces the bandwidth of shorter dipoles, so an impedance-matching unit may be needed to achieve an acceptable SWR across all bands covered. These effects can be reduced by spreading the ends of the dipoles apart. (This is where the name "fan dipole" comes from.)

Also, the power-distribution mechanism requires that only one of the parallel dipoles is near resonance on any amateur band. Separate dipoles for 80 and 30 meters should not be connected in parallel because the higher frequency band is near an odd harmonic of the lower frequency band and center-fed dipoles have low impedance near odd harmonics. (The 40 and 15 meter bands have a similar relationship.) This means that you must either accept the performance of the low-band antenna operating on a harmonic or erect a separate antenna for those odd-harmonic bands. For example, four parallel-connected dipoles cut for 80, 40, 20 and 10 meters (fed by a single impedance-matching unit and coaxial cable) work reasonably on all HF bands from 80 through 10 meters.

The fan dipole technique can also be used to construct a wide-band dipole for 80 and 75 meters. Begin with a full-size 80-meter dipole and tune to a preferred frequency near 3.500 MHz, leaving several feet of wire for adjustment at the end insulators by wrapping it back around the main antenna wire. Add a 75-meter

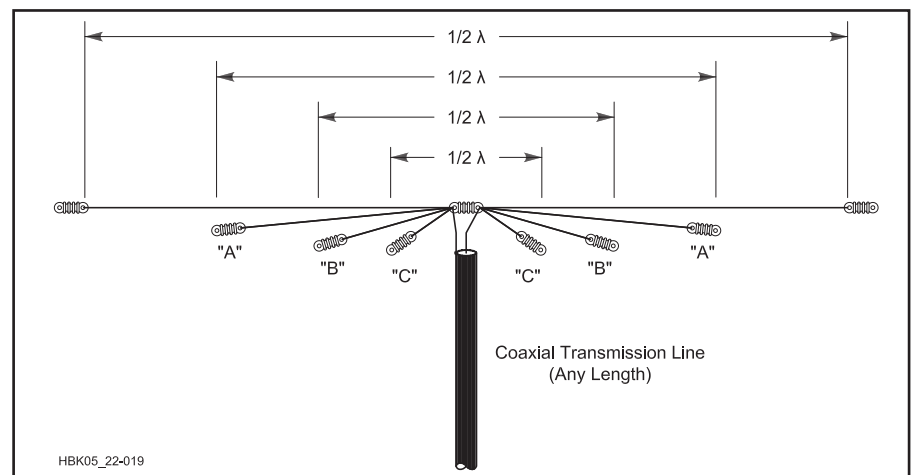

Figure 21.20 — Multiband antenna using paralleled dipoles, all connected to a common 50 or 75 Ω coax line. The $\frac{1}{2}\lambda$ dimensions are chosen for the desired operating frequency on each band — the fundamental, A, B, and C. Be prepared to adjust the length of the various elements — both longer and shorter — because of interaction among them. See text.

dipole for 3.800 MHz, again with extra wire for adjustment, and raise the dipole into the final position. Shorten each dipole in small steps of around one foot until minimum SWR is obtained at the desired frequencies. The adjustments will interact, so avoid cutting off the excess wire until the final lengths are reached.

21.2.12 Trap Dipoles

Trap dipoles (also called “trapped dipoles”) provide multiband operation from a coax-fed single-wire dipole. **Figure 21.21** shows a two-band trap antenna. A trap consists of parallel inductance and capacitance with a resonant frequency on the higher of the two bands of operation. The high impedance of the trap at its resonant frequency effectively disconnects the wire beyond the trap. Thus, on the higher of the two bands of operation at which traps are resonant, only the portion of the antenna between the traps is active.

Above resonance, the trap presents a capacitive reactance. Below resonance, the trap is inductive. On the lower of the two bands of operation, then, the inductive reactance of the trap acts as a loading coil to create a shortened or loaded dipole with the wire beyond the trap.

Traps may be constructed from coiled sections of coax (see the W8NX article in the online information) or from discrete inductors and capacitors. (Traps are also available commercially.) Choose capacitors (C1 in the figure) that are rated for high current and voltage. Mica transmitting capacitors are good. Ceramic “doorknob” transmitting capacitors will work, but be sure to use NP0 temperature coefficient parts to minimize changes in capacitance with temperature. Use large wire for the inductors to reduce loss. Any reactance (X_L and X_C) above $100\ \Omega$ at the resonant frequency will work, but bandwidth increases with reactance (up to several thousand ohms). Check trap resonance before installation. This can be done with a grid-dip meter and a receiver, or with an SWR analyzer or impedance bridge.

To construct a trap antenna, build a dipole for the higher band of operation and connect the pre-tuned traps to its ends. It is fairly complicated to calculate the additional wire needed for each band, so just add enough wire to achieve $\frac{1}{2}$ -wave resonance on the lower band of operation, pruning it as necessary. Because the inductance in each trap reduces the physical length needed for resonance, the finished antenna will be shorter than a simple $\frac{1}{2}\ \lambda$ dipole on the lower band.

21.2.13 Dipoles for NVIS

The use of very low dipole antennas that radiate at high elevation angles for regional communication has become popular in emergency communications (“emcomm”) systems. This works at frequencies (3 to 10 MHz) be-

low the ionosphere’s critical frequency — the highest frequency for which a signal traveling vertically will be reflected. (See the **Propagation** chapter.) The most common band for NVIS communication is 75 meters because the critical frequency is almost always above 4 MHz. 60 meters is growing in popularity, and 40 meters is often useful for NVIS communication through the day.

No special construction techniques are required to use a dipole for NVIS communication. Just build a regular $\lambda/2$ dipole and install it at a height of around 0.2 – $0.3\ \lambda$. At these low heights, the effects of ground will lower the dipole’s resonant frequency and feed point impedance. Expect to shorten the antenna

to achieve resonance. As height increases to $0.5\ \lambda$, a high-angle null develops in the antenna pattern, reducing NVIS effectiveness considerably. See the References entry for Witvliet for a recent paper on the subject.

Below $0.2\ \lambda$, feed point impedance will drop rapidly (see Figure 21.2) and ground losses may become significant. If feed point impedance (at resonance) drops to $40\ \Omega$ or lower, that is an indication of increasing ground loss. Ground screens or reflector wires are not needed due to the efficiency of NVIS propagation. A simple inverted-V dipole at a modest height over normal conductive soil works well, and the dB or two of improvement is not worth the additional complexity of screens or reflectors.

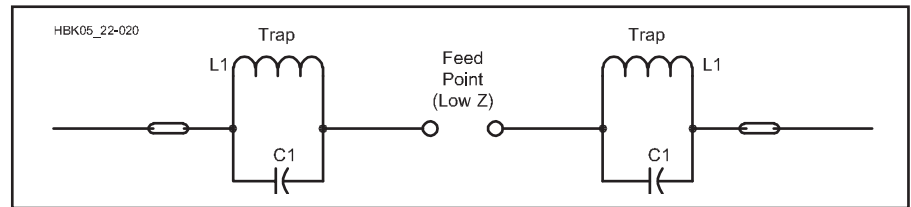

Figure 21.21 — Example of a trap dipole antenna. L1 and C1 can be tuned to the desired frequency by means of a grid-dip meter or SWR analyzer *before* they are installed in the antenna.

Turn a Horizontal Antenna Vertical

An option for adding at least one more band to a flat-top or inverted-V dipole is to turn it into a flat-top T vertical antenna. (See the T and Inverted-L Antennas section.) To do this, disconnect the feed line at the ground level, short the feed line conductors together, and connect them to the transmitter as a single wire. The remaining connection to the transmitter should be connected to a ground rod (as shown), counterpoise, or system of ground radials. (The antenna system’s safety ground connection is still required.) A coaxial feed line is shown but the same technique works just as well for open-wire feed lines. An antenna tuner is required for either type of feed line.

This technique often allows a dipole to be used effectively at frequencies below those at which its horizontal section is resonant. For example, a 40 meter dipole can be used this way on 160 and 80 meters.

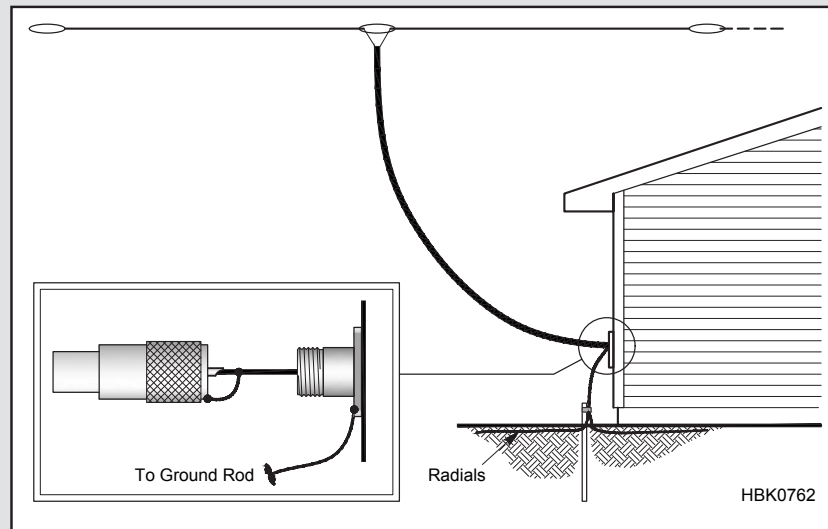

Figure 21.A – A dipole can be fed as a flat-top T vertical antenna by reconfiguring the feed line connections and exciting the antenna against ground.

21.2.14 Off-Center-Fed (OCF) Dipoles

The usual practice is to feed a $\lambda/2$ dipole in the center where the feed point impedance is low and makes a suitable match to coaxial cables. The dipole will accept energy from a feed point anywhere along its length, however, assuming that the source is matched to the higher impedance that is presented away from the center point.

The *off-center-fed* dipole takes advantage of placing the feed point in a location along the dipole at which the impedance is similar on more than one band, generally in the neighborhood of 150-300 Ω . A suitable impedance matching device such as an impedance transformer is then used to reduce the feed point impedance to something closer to 50 Ω . Note that the feed point impedance of the antenna varies with height above ground and so will SWR.

Figure 21.22 shows two off-center-fed or OCF dipoles. Because it is similar in appearance, this antenna is often mistakenly called a “Windom,” or sometimes a “coax-fed Windom.” The two antennas are not the same, since the Windom is driven against an Earth ground, while the OCF dipole is fed like a regular dipole — just not at its center. The extreme case of an OCF is the end-fed Zepp where the feed point is moved all the way to the end of the antenna.

The OCF dipole, fed $1/3$ of its length from one end, may be used on its fundamental and even harmonics. Its free-space antenna-terminal impedance at 3.5, 7, and 14 MHz is on the order of 150 to 200 Ω . At the 6th harmonic, 21 MHz, the antenna is three wavelengths long and fed at a voltage maximum instead of a current maximum. The feed point impedance at this frequency is high, a few thousand ohms, so the antenna is unsuitable for use on this band. OCF dipole designs for various HF bands by NT4B, K1BQT, K1LL, and KE4PT are included in the online material for this chapter.

IMPEDANCE TRANSFORMER AND BALUN REQUIREMENTS

All OCF dipole antennas require an impedance transformer at the feed point. A 4:1 or 6:1 ratio typically provides good results. A choke balun on the feed line is also required to reduce coupling between the antenna and feed line, which can affect feed point impedance. Height above ground also affects feed point impedance — be prepared to adjust the dipole length to achieve an acceptable match on the bands to be used.

Because the OCF dipole is not fed at the center of the radiator, the feed line is not placed symmetrically with respect to the antenna’s radiated field. As a result, common-mode current will flow on the feed line, usually coaxial cable. How much current flows de-

pends on the impedance of the coax shield’s outer surface, which, in turn, depends on the orientation of the cable, how long it is, height above ground, and so forth. (Some of the common-mode current results from the slightly unequal impedances presented by the OCF legs, but most of the shield current results from the feed line’s asymmetric location in the antenna’s field.)

Regardless of the cause, common-mode current flow on the feed line is generally viewed as undesirable and a current or choke balun is used to increase the impedance of coax shield’s outer surface. Radiation from the feed line may not be a problem in your installation and may even improve the antenna’s radiation pattern by filling in nulls. In that case, no choke balun is required. (Feed line chokes are discussed in the chapter **Transmission Lines**.)

Project: Multiband Center-Fed Dipole

An 80 meter dipole fed with ladder line is a versatile antenna. If you add a wide-range matching network, you have a low-cost antenna system that works well across the entire HF spectrum, even 6 meters. Countless hams have used one of these in single-antenna stations and for Field Day operations.

Figure 21.23 shows a typical installation for such an antenna. The inverted-V configuration is shown, lowering the total antenna length to 130 feet from the 135 feet used if the entire antenna is horizontal. Either configuration will work well. You can use a balanced impedance-

matching unit with a balun between it and the transmitter. Many amateurs are successful in using unbalanced impedance-matching units with a balun at either the output or the input of the tuner. Don’t be afraid to experiment!

This configuration is popular with other lengths for the antenna:

- 105 feet — 80 through 10 meters
- 88 feet — 80 through 10 meters
- The next lower band may also be covered if the impedance-matching unit has sufficient range, although the adjustment will be fairly sharp. Six meter coverage is possible but de-

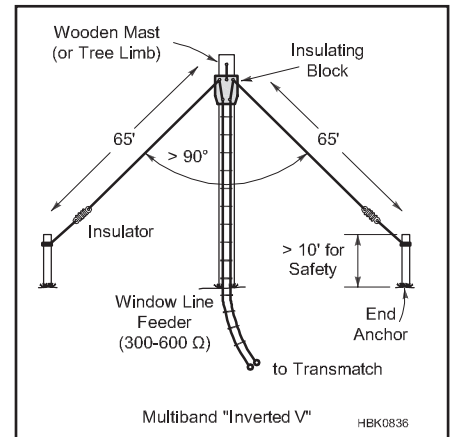

Figure 21.23 — Details for an inverted-V fed with open-wire line for multiband HF operation. The included angle between the two legs should be greater than 90° for best performance.

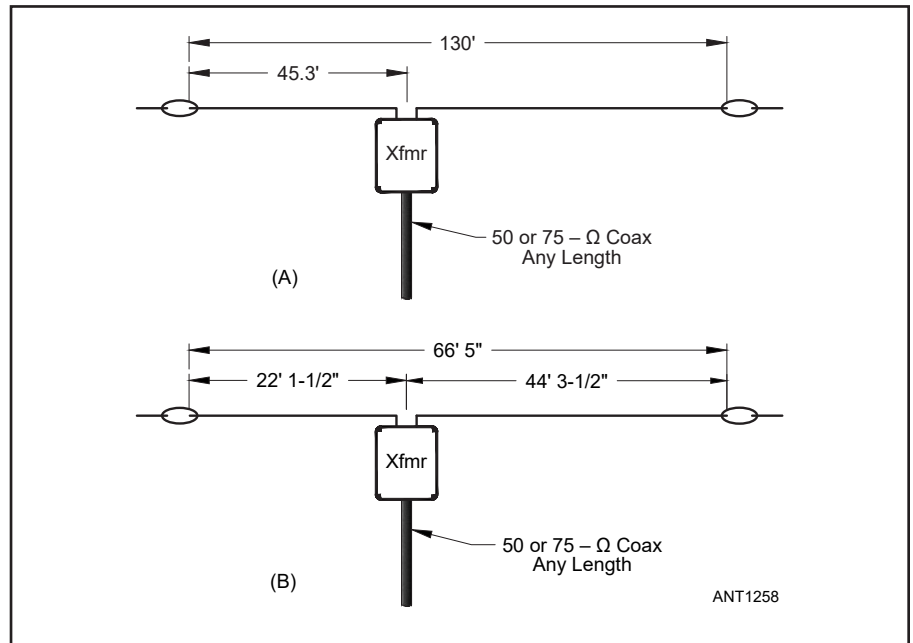

Figure 21.22 – Off-center-fed (OCF) dipoles for use on several bands. Length A is generally $\lambda/2$ on the lowest frequency of operation. Length B is usually approximately $1/3$ of A. The impedance transformer is typically a 4:1 or 6:1 design. A feed line choke at the impedance transformer will provide feed line isolation, if desired. Feed point impedance and SWR will be affected by the antenna’s height above ground.

depends on the station layout, length of feed line, and impedance-matching unit abilities. Again, don't be afraid to experiment!

For best results place the antenna as high as you can, and keep the antenna and ladder line clear of metal and other conductive objects. Despite significant SWR on some bands, the open-wire feed line keeps system losses low, as described in the **Transmission Lines** chapter.

ARRL staff analyzed a 135 foot dipole at 50 feet above typical ground and compared that to an inverted-V with the center at 50 feet, and the ends at 10 feet. The results show that on the 80 meter band, it won't make much difference which configuration you choose. The inverted-V exhibits additional losses because of its proximity to ground. (Radiation patterns are available in the online information.)

Installed horizontally, or as an inverted-V, the 135 foot center-fed dipole is a simple antenna that works well from 3.5 to 30 MHz (and on 1.8 MHz if the impedance-matching unit has sufficient range). The feed line impedance at the transmitter end may be out of range for the impedance-matching unit. In such a case, add $\frac{1}{8}$ wavelength of feed line at that frequency. This may change the impedance to a value the impedance-matching unit can handle.

Project: 40 to 15 Meter Dual-Band Dipole

As mentioned earlier, dipoles have harmonic resonances at odd multiples of their fundamental resonances. Because 21 MHz is the third harmonic of 7 MHz, 7 MHz dipoles are harmonically resonant in the popular ham band at 21 MHz. This is attractive because it allows you to install a 40 meter dipole, feed it with coax, and use it without an antenna tuner on both 40 and 15 meters.

But there's a catch: The third harmonic resonance is actually higher than three times the fundamental resonant frequency. This is because there is no end effect in the center portion of the antenna where there are no insulators.

An easy fix for this, as shown in **Figure 21.24**, is to add capacitive loading to the an-

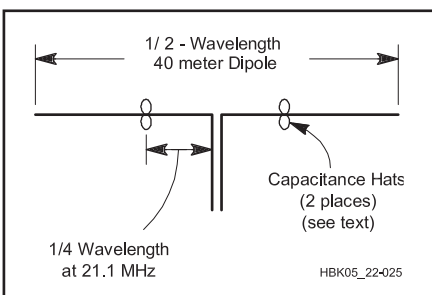

Figure 21.24 — Figure-8-shaped capacitance hats made and placed as described in the text, can make a 40 meter dipole resonate anywhere in the 15 meter band.

tenna about $\frac{1}{4} \lambda$ wavelength (at 21.2 MHz) away from the feed point in both halves of the dipole. Known as *capacitance hats*, the simple loading wires shown lower the antenna's resonant frequency on 15 meters without substantially affecting resonance on 40 meters. This scheme can also be used to build a dipole that can be used on 80 and 30 meters and on 75 and 10 meters. (A project for a 75 and 10 meter dipole is included with the online content.)

Measure, cut, and adjust the dipole to resonance at the desired 40 meter frequency. Then, cut two 2-foot-long pieces of stiff wire (such as #12 or #14 AWG house wire) and solder the ends of each one together to form two loops. Twist the loops in the middle to form figure-8s, and strip and solder the wires where they cross. Install these capacitance hats on the dipole by stripping the antenna wire (if necessary) and soldering the hats to the dipole about a third of the way out from the feed point (placement isn't critical) on each wire. To resonate the antenna on 15 meters, use an antenna analyzer to adjust the loop shapes until the SWR is acceptable in the desired segment of the 15 meter band. Conversely, you can move the hats back and forth along the antenna until the desired SWR is achieved and then solder the hats to the antenna.

Project: W4RNL Rotatable Dipole Inverted-U Antenna

This simple rotatable dipole was designed and built by L.B. Cebik, W4RNL (SK), for use during the ARRL Field Day. For this and other portable operations we look for three antenna characteristics: simplicity, small size, and light weight. Today, a number of light-weight collapsible masts are available. When properly guyed, some will support antennas in the 5 to 10 pound range. Most are suitable for 10 meter tubular dipoles and allow the user to hand-rotate the antenna. Extend the range of the antenna to cover 20 through 10 meters, and you put these 20 to 30 foot masts to even better use. The inverted-U meets this need. **Figure 21.25** shows the basic kit for the antenna. Complete construction details and more information about antenna performance are available with the online content.

A dipole's highest current occurs within the first half of the distance from the feed point to the outer tips. Therefore, very little performance is lost if the outer end sections are bent. The W4RNL inverted-U starts with a 10 meter tubular dipole. You add wire extensions for 12, 15, 17 or 20 meters to cover those bands.

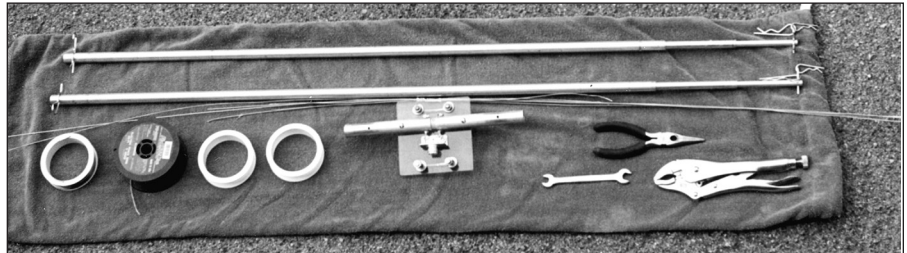

Figure 21.25 — The entire inverted-U antenna parts collection in semi-nested form, with its carrying bag. The tools stored with the antenna include a wrench to tighten the U-bolts for the mast-to-plate mount and a pair of pliers to help remove end wires from the tubing.

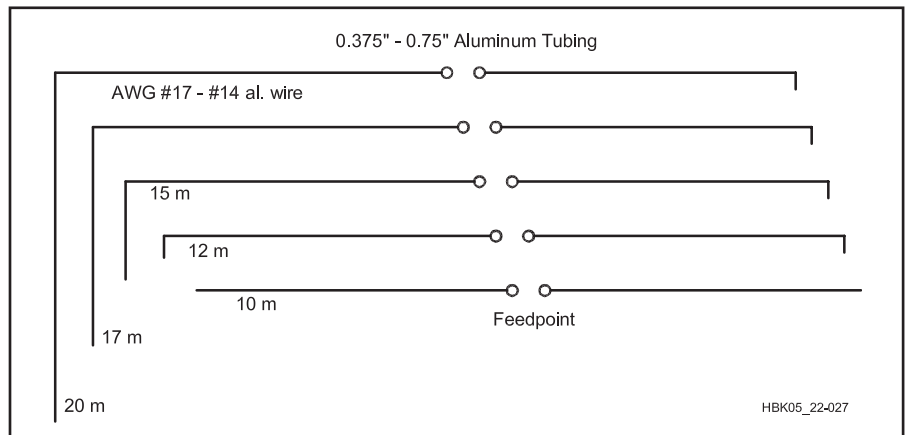

Figure 21.26 — The general outline of the inverted-U field dipole for 20 through 10 meters. Note that the vertical end extension wires apply to both ends of the main 10 meter dipole, which is constant for all bands.

You only need enough space to erect a 10 meter rotatable dipole. The extensions hang down. **Figure 21.26** shows the relative proportions of the antenna on all bands from 10 to 20 meters. The 20 meter extensions are the length of half the 10 meter dipole.

Not much signal strength is lost by drooping up to half the overall element length straight down. What is lost in bidirectional gain shows up in decreased side nulls. There is an undetectable decrease in gain between the 10 meter and 15 meter versions. The 20 meter version shows a little over ½ dB gain decrease and a signal increase off the antenna ends.

The feed point impedance of the inverted-U remains well within acceptable limits for virtually all equipment, even at 20 feet above ground. Also, the SWR curves are very broad, so it's not as critical to find exact dimensions, even for special field conditions.

Changing bands is a simple matter. Remove the extensions for the band you are using and install the ends for the new band. An SWR check and possibly one more adjustment of the end lengths will put you back on the air.

With a dipole having drooping ends, safety is very important. At any power level, the ends of a dipole have high RF voltages, and we must keep them out of contact with human body parts. Do not use the antenna unless the wire ends for 20 meters are higher than any person can touch when the antenna is in use. Even with QRP power levels, the RF voltage on the wire ends can be dangerous. With the antenna at 20 feet at its center, the ends should be at least 10 feet above ground.

Project: Two W8NX Multiband, Coax-Trap Dipoles

Two different antennas are described here. The first covers the traditional 80, 40, 20, 15 and 10 meter bands, and the second covers 80, 40, 17 and 12 meters. (The complete article describing these antenna projects is available as part of this book's online information.) Each uses the same type of W8NX trap — connected for different modes of operation — and a pair of short capacitive stubs to enhance coverage. The W8NX coaxial-cable traps have two different modes: a high- and a low-impedance mode. The inner-conductor windings and shield windings of the traps are connected in series for both modes. However, either the low- or high-impedance point can be used as the trap's output terminal. For low-impedance trap operation, only the center conductor turns of the trap windings are used. For high-impedance operation, all turns are used in the conventional manner for a trap. The short stubs on each antenna are strategically sized and located to permit more flexibility in adjusting the resonant frequencies of the antenna.

80, 40, 20, 15 AND 10 M DIPOLE

Figure 21.27 shows the configuration of the 80, 40, 20, 15 and 10 meter antenna. The radiating elements are made of #14 AWG stranded copper wire. The element lengths are the wire span lengths in feet. These lengths do not include the lengths of the pigtails at the balun, traps, and insulators. The 32.3-foot-long inner 40 meter segments are measured from the eyelet of the input balun to the tension-relief hole in the trap coil form. The 4.9 foot segment length is measured from the tension-relief hole in the trap to the 6 foot stub. The 16.1 foot outer-segment span is measured from the stub to the eyelet of the end insulator.

80, 40, 17 AND 12 METER DIPOLE

Figure 21.28 shows the configuration of the 80, 40, 17 and 12 meter antenna. Notice that the capacitive stubs are attached immediately outboard after the traps and are 6.5 feet long, ½ foot longer than those used in the other antenna. The traps are the same as those of the other antenna, but are connected for the high-impedance parallel-resonant output mode. Since only four bands are covered by this antenna, it is easier to fine tune it to precisely the desired frequency on all bands.

Project: Triband Dipole for 30, 17, and 12 Meters

(This antenna was originally described in the article “A Triband Dipole for 30, 17, and 12 Meters” by Zack Lau, W1VT, in the Mar/Apr 2015 issue of *QEX*. A similar design by W1VT for 10, 20, and 40 meters described in the ar-

ticle “A Compact Multiband Dipole” from the March 2016 issue of *QST*. Both articles are available as PDF files with the online content.)

The triband dipole in **Figure 21.29** is a 58 foot doublet made out of #14 THHN solid house wire fed with a 35.5 foot matching section of 600 Ω ladder line having a velocity factor of 0.91. It has modest gain over a dipole on all three of the design bands, and SWR at the balun input is approximately 1.5:1 on 17 meters and 2.4:1 on 12 meters and 30 meters. These values of SWR are all easily matched to 1:1 with the auto-tuner built into many transceivers, or with an external impedance matching unit.

If the antenna will be installed at a significantly different height, the length of the doublet and the open-wire feed line may have to be adjusted to obtain resonances in all three bands. The length of the 50 Ω cable feed line isn't critical.

The #14 THHN house wire has two layers of insulation: 15 mils of PVC and another 4 mils of nylon. While the nylon typically flakes off in less than a year, the antenna was modeled in *EZNEC* using an insulation thickness of 19 mils and a dielectric constant of 3.5. Changing the insulation thickness to 15 mils doesn't appreciably change the resonance points.

The somewhat low velocity factor of the open-wire line assumes it is constructed using the same insulated wire as the doublet. A spacing of 3 inches is recommended for constructing the 600 Ω open-wire line. If other wire types are used to construct the open-wire line, an accurate approximation for the impedance of air-insulated open-wire line is:

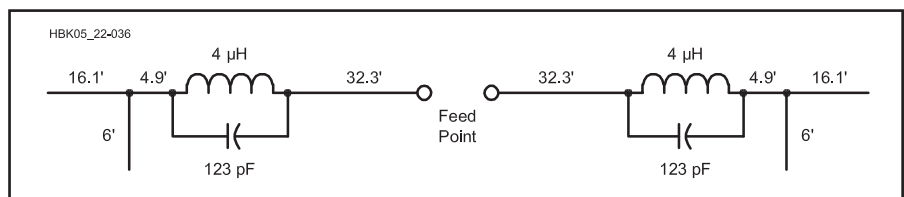

Figure 21.27 — A W8NX multiband dipole for 80, 40, 20, 15 and 10 meters. The values shown (123 pF and 4 μH) for the coaxial-cable traps are for parallel resonance at 7.15 MHz. The low-impedance output of each trap is used for this antenna.

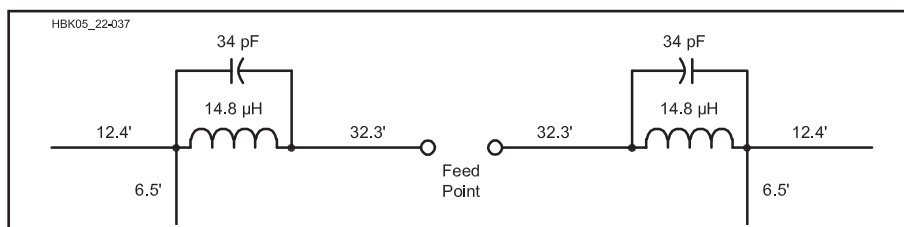

Figure 21.28 — A W8NX multiband dipole for 80, 40, 17 and 12 meters. For this antenna, the high-impedance output is used on each trap. The resonant frequency of the traps is 7.15 MHz.

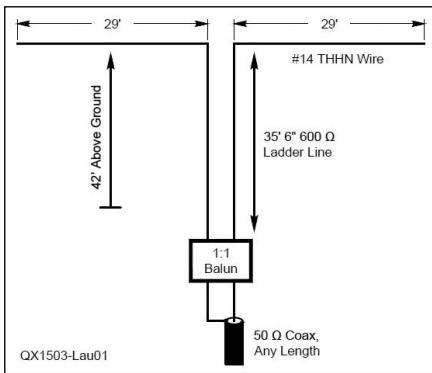

Figure 21.29 — Basic configuration of the triband dipole, consisting of a 58-foot doublet fed with 35.5 feet of 600 Ω open-wire feed line. SWR at the balun input is approximately 1.5:1 on 17 meters and 2.4:1 on 12 meters and 30 meters.

$$Z_0 = 276 \log_{10} (2S/d) \quad (5)$$

where S is the center-to-center distance between the conductors and d is the diameter of the conductors in the same units as S . (Z_0 for open-wire line is discussed in detail in the “Fundamentals” section of the **Transmission Lines** chapter.)

A 1:1 current or choke balun is required between the open wire feed line and the coax to prevent the outside of the coax shield from becoming a radiating antenna element and affecting feed point impedance. (See the section “Baluns and Transmission Line Transformers” in the **Transmission Lines** chapter.) The author recommends 11 turns of RG-58A/U on an FT-140-43 core as working well from 10 to 30 MHz. Steve Hunt, G3TXQ published an

excellent balun design using 11 turns of RG-58 on a stacked pair of FT-240-52 toroids that provides a higher choking impedance, which may be necessary if the antenna is to be used on other bands than 30, 17, or 12 meters where the open-wire line length does not result in a low impedance.

Assuming a height of 42 feet, on 17 meters the antenna has a clean, bidirectional pattern, with maximum gain of 8.9 dBi broadside to the wires, just like a dipole. (All antenna patterns are included in the full article.) On 30 meters, the antenna also has gain broadside to the wires of 6.9 dBi. On 12 meters the antenna has an azimuthal radiation pattern with four main lobes having 8.2 dBi gain, 50° off broadside. The broadside lobes are 3.5 dB weaker than the main lobes.

21.3 Vertical (Ground-Plane) Antennas

One of the more popular amateur HF antennas is the *vertical*. It usually refers to a single radiating element erected vertically over a *ground plane* of radial wires. A typical vertical is $\frac{1}{4} \lambda$ long electrically and is constructed of wire or tubing. The vertical antenna is more accurately named the ground plane because the conductive surface (the ground plane) creates a path for return currents to the feed point, effectively creating the “missing half” of a $\frac{1}{2} \lambda$ antenna. Another name for this type of antenna is the *monopole* (sometimes *unipole*).

The ground plane can be a solid, conducting surface, such as a vehicle body at VHF/UHF mobile antenna. At HF, this is impractical and systems of *ground radials* are used: wires laid out on the ground radially from the base of the antenna. One conductor of the feed line is attached to the vertical radiating element of the antenna, and the remaining conductor is attached to the ground plane. The radial wires form a *ground screen* that gives the return currents a low-resistance path instead of flowing through lossy soil.

Single vertical antennas are omnidirectional radiators. This can be beneficial or detrimental, depending on the situation. On transmission there are no nulls in any direction, unlike most horizontal antennas. However, QRM on receive can’t be nulled out from the directions that are not of interest unless multiple verticals are used in an array.

Ground-plane antennas need not be mounted vertically. A ground-plane antenna can operate in any orientation as long as the ground plane is perpendicular to the radiating element. Other considerations, such as minimizing cross-polarization between stations,

may require a specific mounting orientation. In addition, due to the size of HF antennas, mounting them vertically is usually the most practical solution.

A vertical antenna can be mounted at the Earth’s surface, in which case it is a *ground-mounted vertical*. The ground plane is then constructed on the surface of the ground. A vertical antenna and the associated ground plane can also be installed above the ground. This often reduces ground losses, but it is more difficult to install the necessary number of radials. *Ground-independent* verticals are often mounted well above the ground because their operation does not rely on a ground plane.

21.3.1 Ground Systems

When compared to horizontal antennas, verticals also suffer more acutely from two main types of losses — *ground return losses* for currents in the near field, and *far-field ground losses*. Ground losses in the near field can be minimized by using many ground radials. This is covered in the sidebar, “Optimum Ground Systems for Vertical Antennas.”

Far-field losses are highly dependent on the conductivity and dielectric constant of the soil around the antenna, extending out as far as 100 wavelengths from its base. There is very little that someone can do to change the character of the ground that far away — other than moving to a small island surrounded by saltwater! Far-field losses greatly affect low-angle radiation, causing the radiation patterns of practical vertical antennas to fall far short of theoretical patterns over *perfect ground*, often seen in classical texts.

Figure 21.30 shows the elevation pattern

response for two different 40 meter quarter-wave verticals. One is placed over a theoretical infinitely large, infinitely conducting ground. The second is placed over an extensive radial system over average soil, having a conductivity of 5 mS/m and a dielectric constant of 13. This sort of soil is typical of heavy clay found in pastoral regions of the US mid-Atlantic states. At a 10° elevation angle, the real antenna losses are almost 6 dB compared to the theoretical antenna; at 20° the difference is about 3 dB. See *The ARRL Antenna Book* chapter on the effects of ground for further details.

While real verticals over real ground are not a magic method to achieve low-angle radiation, cost versus performance and ease of installation are incentives that inspire many

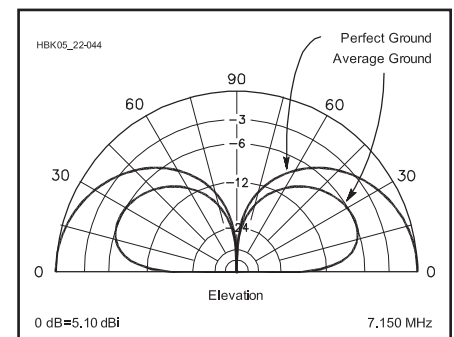

Figure 21.30 — Elevation patterns for two quarter-wave vertical antennas over different ground. One vertical is placed over perfect ground, and the other is placed over average ground. The far-field response at low elevation angles is greatly affected by the quality of the ground — as far as 100 λ away from the vertical antenna.

antenna builders. For use on the lower frequency amateur bands — notably 160 and 80 meters — it is not always practical to erect a full-size vertical. At 1.8 MHz, a full-sized quarter-wave vertical is 130 feet high. In such instances it is often necessary to accept a shorter radiating element and use some form of loading.

Figure 21.31 provides curves for the physical height of verticals in wavelength versus radiation resistance and reactance. Although the plots are based on perfectly conducting ground, they show general trends for installations where many radials have been laid out to make a ground screen. As the radiator is made shorter, the radiation resistance decreases — with 6Ω being typical for a 0.1λ high antenna. The lower the radiation resistance, the more the antenna efficiency depends on ground conductivity and the effectiveness of the ground screen. Also, the bandwidth decreases markedly as the length is reduced toward the left of the scale in Figure 21.31. It can be difficult to develop suitable matching networks when radiation resistance is very low.

Generally a large number of shorter radials results in a better ground system than a few longer ones. For example, eight $\frac{1}{4} \lambda$ radials are preferred over four $\frac{1}{2} \lambda$ radials. Optimum radial lengths are described in the sidebar.

The conductor size of the radials is not especially significant. Wire gauges from #4 to #20 AWG have been used successfully by amateurs. Copper wire is preferred, but where soil is low in acid (or alkali), aluminum wire can be used. The wires may be bare or insulated, and they can be laid on the surface or buried a few inches below ground. Insulated wires will have greater longevity by virtue of reduced corrosion and dissolution from soil chemicals.

When property dimensions do not allow a classic installation of equally spaced radial

wires, they can be placed on the ground as space permits. They may run away from the antenna in only one or two compass directions. They may be bent to fit on your property. Hardware cloth and chicken wire are also quite effective, although the galvanizing must be of high quality to prevent rapid rusting.

A single ground rod, or group of them bonded together, is seldom as effective as a collection of random-length radial wires. (A ground rod at the vertical's base should be used for lightning protection.)

All radial wires should be connected together at the base of the vertical antenna. The electrical bond needs to be of low resistance. Best results will be obtained when the wires are soldered together at the junction point. When a grounded vertical is used, the ground wires should be affixed securely to the base of the driven element.

Ground return losses are lower when vertical antennas and their radials are elevated above ground, a point that is well known by those using ground plane antennas on their

Optimum Ground Systems for Vertical Antennas

A frequent question brought up by old-timers and newcomers alike is: “So, how many ground radials do I *really* need for my vertical antenna?” Most hams have heard the old standby tales about radials, such as “if a few are good, more must be better” or “lots of short radials are better than a few long ones.”

John Stanley, K4ERO, eloquently summarized a study he did of the professional literature on this subject in his article “Optimum Ground Systems for Vertical Antennas” in December 1976 *QST*. His approach was to present the data in a sort of “cost-benefit” style in **Table 21.A**, reproduced here. John somewhat wryly created a new figure of merit — the total amount of wire needed for various radial configurations. This is expressed in terms of wavelengths of total radial wire.

Table 21.A

Optimum Ground-System Configurations

Configuration Designation	A	B	C	D	E	F
Number of radials	16	24	36	60	90	120
Length of each radial in wavelengths	0.1	0.125	0.15	0.2	0.25	0.4
Spacing of radials in degrees	22.5	15	10	6	4	3
Total length of radial wire installed, in wavelengths	1.6	3	5.4	12	22.5	48
Power loss in dB at low angles with a quarter-wave radiating element	3	2	1.5	1	0.5	0*
Feed point impedance in ohms with a quarter-wave radiating element	52	46	43	40	37	35

Note: Configuration designations are indicated only for text reference.

*Reference. The loss of this configuration is negligible compared to a perfectly conducting ground.

The results almost jumping out of this table are:

- If you can only install 16 radials (Case A), they needn't be very long — 0.1λ is sufficient. You'll use 1.6λ of radial wire in total, which is about 450 feet at 3.5 MHz.
- If you have the luxury of laying down 120 radials (Case F), they should be 0.4λ long, and you'll gain about 3 dB over the 16 radial case. You'll also use 48λ of total wire — For 80 meters, that would be about 13,500 feet!
- If you can't put out 120 radials but can install 36 radials that are 0.15λ long (Case C), you'll lose only 1.5 dB compared to the optimal Case F. You'll also use 5.4λ of total wire, or 1,500 feet at 3.5 MHz.
- A 50Ω SWR of 1:1 isn't necessarily a good thing — the worst-case ground system in Case A has the lowest SWR.

Table 21.A represents the case for “average” quality soil, and it is valid for radial wires either laid on the ground or buried several inches in the ground. Note that such ground-mounted radials are detuned because of their proximity to that ground and hence don't have to be the classical quarter-wavelength that they need to be in “free space.”

In his article John also made the point that ground-radial losses would only be significant on transmit, since the atmospheric noise on the amateur bands below 30 MHz is attenuated by ground losses, just as actual signals would be. This limits the ultimate signal-to-noise ratio in receiving.

So, there you have the tradeoffs — the loss in transmitted signal compared to the cost (and effort) needed to install more radial wires. You take your pick.

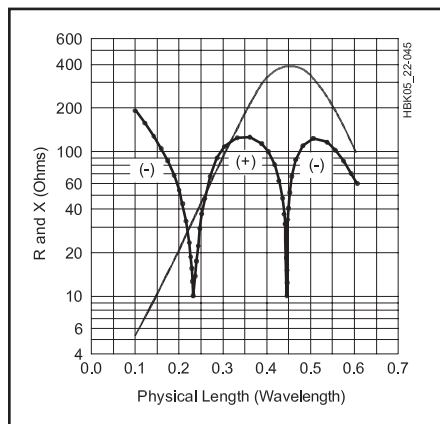

Figure 21.31 — Radiation resistance (solid curve) and reactance (dotted curve) of vertical antennas as a function of their electrical height.

roofs. Even on 160 or 80 meters, effective vertical antenna systems can be made with as few as four $\frac{1}{4} \lambda$ long radials elevated 10 to 20 feet off the ground.

21.3.2 Full-Size Vertical Antennas

When it is practical to erect a full-size $\frac{1}{4} \lambda$ vertical antenna, the forms shown in **Figure 21.32** are worthy of consideration. The example at A is the well-known *vertical ground plane*. The ground system consists of four above-ground radial wires. The length of the driven element and $\frac{1}{4} \lambda$ radials is derived from the standard equation

$$L(\text{ft}) = 234 / f(\text{MHz}) \quad (6)$$

With four equidistant radial wires drooped at approximately 30° (Figure 21.32A), the feed point impedance is roughly 50Ω . When the radials are at right angles to the radiator (Figure 21.32B), the impedance approaches 36Ω .

Besides minimizing ground return losses, another major advantage in this type of vertical antenna over a ground-mounted type is that the system can be elevated well above nearby conductive objects (power lines, trees, buildings and so on). When drooping radials are used, they can also serve as guy wires for the mast that supports the antenna. The coax shield braid is connected to the radials, and the center conductor to the driven element.

The *Marconi* vertical antenna shown in Figure 21.32C is the classic form taken by a ground-mounted vertical. It can be grounded at the base and *shunt fed*, or it can be isolated from ground, as shown, and *series fed*. As always, this vertical antenna depends on an effective ground system for efficient performance. If a perfect ground were located below the antenna, the feed impedance would be near 36Ω . In a practical case, owing to imperfect ground, the impedance is more likely to be in the vicinity of 50Ω .

Vertical antennas can be longer than $\frac{1}{4} \lambda$, too; $\frac{3}{8} \lambda$, $\frac{1}{2} \lambda$, and $\frac{3}{4} \lambda$ verticals can all be used with good results, although none will present a 50Ω feed point impedance at the base. Non-resonant lengths have become popular for the same reasons as non-resonant horizontal antennas; when fed with low-loss feed line and a wide-range impedance matching unit, the antenna can be used on multiple bands. Various matching networks, described in the **Transmission Lines** chapter, can be employed. Antenna lengths above $\frac{1}{2} \lambda$ are not recommended because the radiation pattern begins to break up into more than one lobe, developing a null at the horizon at 1λ .

A gamma-match feed system for a grounded $\frac{1}{4} \lambda$ vertical is presented in Figure 21.32D. (The gamma match is also discussed in the

Transmission Lines chapter.) Some rules of thumb for arriving at workable gamma-arm and capacitor dimensions are to make the rod length 0.04 to 0.05λ , its diameter $\frac{1}{3}$ to $\frac{1}{2}$ that of the driven element, and the center-to-center spacing between the gamma arm and the driven element roughly 0.007λ . The capacitance of C1 at a 50Ω matched condition will be about 7 pF per meter of wavelength. The absolute value of C1 will depend on whether the vertical is resonant and on the precise value of the radiation resistance. For best results, make the radiator approximately 3% shorter than the resonant length.

Amateur antenna towers lend themselves to use as shunt-fed verticals, even though an HF-band beam antenna is usually mounted on the tower. The overall system should be close to resonance at the desired operating frequency if a gamma feed is used. The HF-band beam will contribute somewhat to *top loading* of the tower. The natural resonance of such a system can be checked by dropping a #12 or #14 AWG wire from the top of the tower (connecting it to the tower top) to form a folded monopole (Figure 21.32E). A four- or five-turn link can be inserted between the lower end of the drop wire and the ground system. A dip meter is then inserted in the link or an antenna analyzer coupled to the link to determine the resonant frequency. Shunt feeding towers is discussed extensively in the *ARRL Antenna Book* and in

ON4UN's *Low Band DXing*.

If the tower is equipped with guy wires, they should be broken up with strain insulators to prevent unwanted loading of the vertical. In such cases where the tower and beam antennas are not able to provide $\frac{1}{4} \lambda$ resonance, portions of the top guy wires can be used as top-loading capacitance. Experiment with the guy-wire lengths (using the dip-meter technique) while determining the proper dimensions. Modeling can save a lot of time in this part of the design.

A folded-monopole is depicted in Figure 21.32E. This system has the advantage of increased feed point impedance. Furthermore, an impedance-matching unit can be connected between the bottom of the drop wire and the ground system to permit operation on more than one band. For example, if the tower is resonant on 80 meters, it can be used as shown on 160 and 40 meters with reasonable results, even though it is not electrically long enough on 160 to act as a full-size antenna. The drop wire need not be a specific distance from the tower, but you might try spacings between 12 and 30 inches.

The method of feed shown at Figure 21.32F is commonly referred to as *slant-wire feed*. The guy wires and the tower combine to provide quarter-wave resonance. A matching network is placed between the lower end of one guy wire and ground and adjusted for an

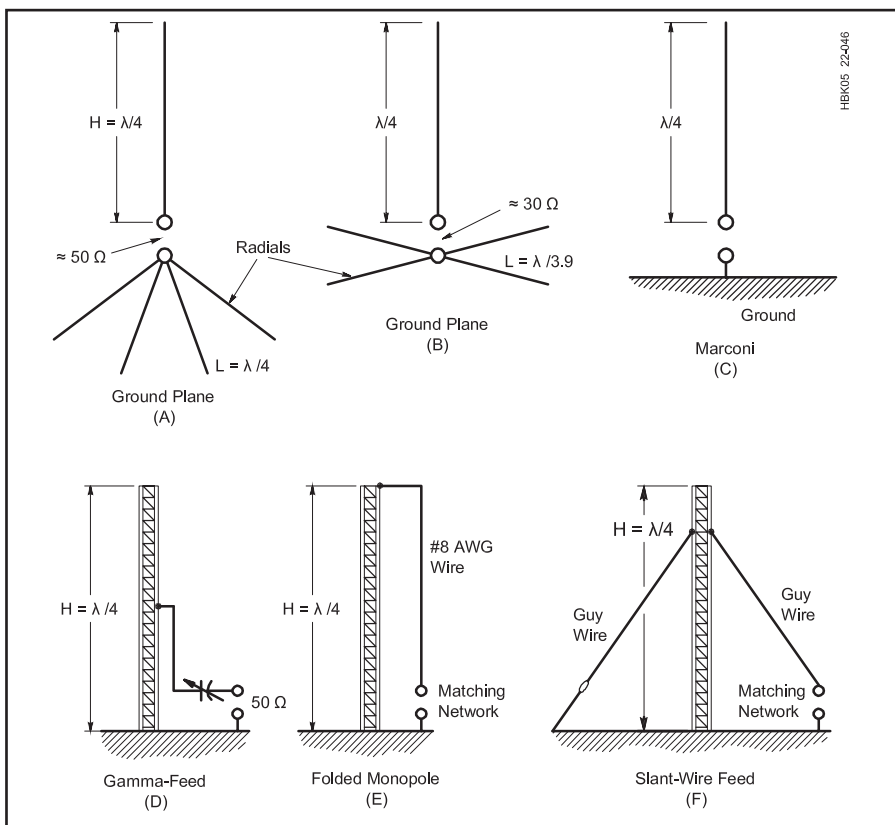

Figure 21.32 — Various types of one-quarter wavelength vertical antennas.

SWR of 1:1. It does not matter at which level on the tower the guy wires are connected, assuming that the impedance-matching unit is capable of effecting a match to 50 Ω.

3/8-Wavelength Verticals

The 3/8-wavelength vertical antenna is often an overlooked design. It has several advantages over the common quarter-wave vertical and just adds 50% to the height. Here are some advantages:

- It has a low takeoff angle of radiation at 23° compared to 26° for the 1/4-wavelength antenna.
- It will work well even ground-mounted because its maximum radiation point is 1/8 wavelength above the ground. This is above the typical clutter present at ground level.
- Its feed point impedance is easy to match for a wide bandwidth with low SWR.
- Finally, it has a much higher radiation impedance. Therefore, only four 1/4-λ radials are required for good performance, although more radials will reduce ground losses.

For 20 meters, a vertical height of 26 feet with 17.5-foot radials has a series impedance of approximately 200 Ω resistive with a series inductive reactance of 300 to 700 Ω. Therefore, a 4:1 transformer will match the resistive component, and a series inductor tunes out the inductive reactance. Typically, the required series capacitance is approximately 40 to 50 pF at 14 MHz and is not critical. The design is easy to scale to other bands. See the article by Joe Reisert, W1JR, in the online material for the details of construction and matching.

21.3.3 Physically Short Verticals

A group of short vertical radiators is presented in **Figure 21.33**. Illustrations A and B are for top and center loading. A capacitance hat is shown in each example. The hat should be as large as practical to increase the radiation resistance of the antenna and improve the bandwidth. The wire in the loading coil is chosen for the largest gauge consistent with ease of winding and coil-form size. The larger wire diameters will reduce the resistive (I^2R) losses in the system. The coil-form material should have a medium or high dielectric constant. Phenolic or fiberglass tubing is entirely adequate.

A base-loaded vertical is shown at C of **Figure 21.33**. The primary limitation is that the high current portion of the vertical exists in the coil rather than the driven element. With center loading, the portion of the antenna below the coil carries high current, and in the top-loaded version the entire vertical element carries high current. Since the high-current part of the antenna is responsible

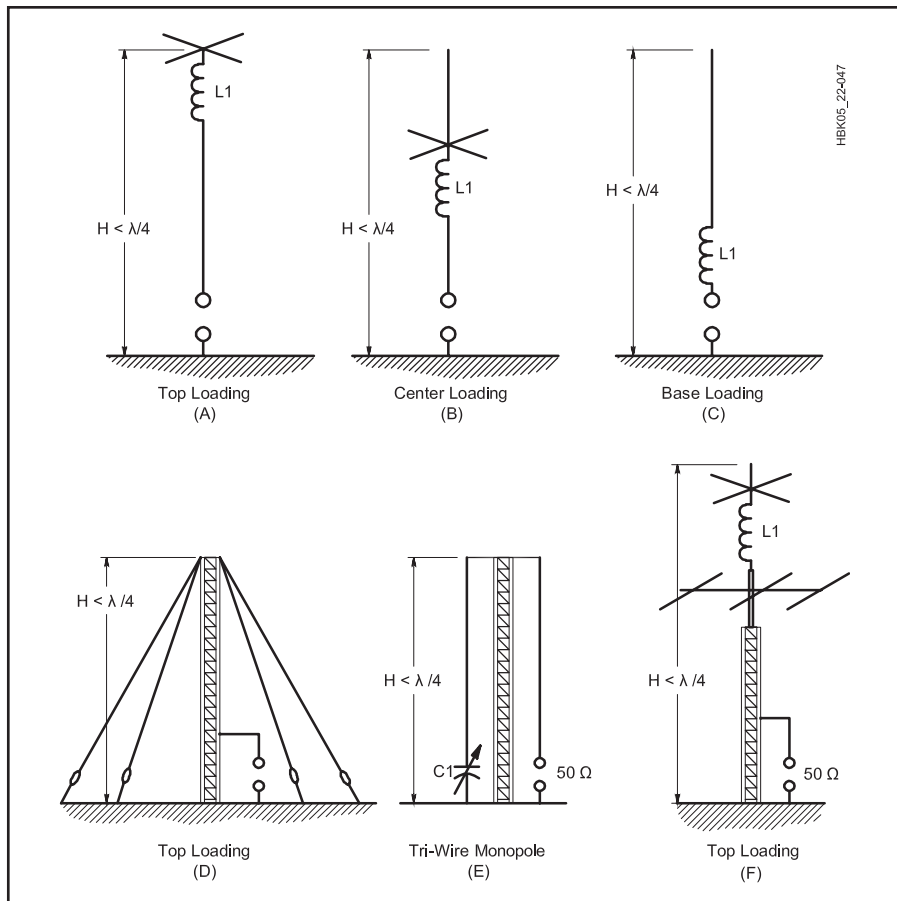

Figure 21.33 — Vertical antennas that are less than one-quarter wavelength in height.

for most of the radiating, base loading is the least effective of the three methods. The radiation resistance of the coil-loaded antennas shown is usually less than 16 Ω.

A method for using guy wires to top load a short vertical is illustrated in **Figure 21.33D**. This system works well with gamma feed. The loading wires are trimmed to provide an electrical quarter wavelength for the overall system. This method of loading will result in a higher radiation resistance and greater bandwidth than the systems shown in A through C. If an HF or VHF array is at the top of the tower, it will simply contribute to the top loading.

A three-wire monopole is shown in **Figure 21.33E**. Two #8 AWG drop wires are connected to the top of the tower and brought to ground level. The wires can be spaced at any convenient distance from the tower — normally 12 to 30 inches from the sides. C1 is adjusted for best SWR. This type of vertical has a fairly narrow bandwidth, but because C1 can be motor driven and controlled from the operating position, frequency changes can be accomplished easily. This technique will not be suitable for matching to 50 Ω line unless the tower is less than an electrical quarter wavelength high.

A different method for top loading is shown in **Figure 21.33F**. Barry Boothe, W9UCW, described this method in the December 1974 *QST*. An extension is used at the top of the tower to create an electrical quarter-wavelength vertical. L1 is a loading coil with sufficient inductance to provide antenna resonance. This type of antenna lends itself to operation on 160 meters.

Project: Top-Loaded Low-Band Antenna

The short, top-loaded vertical antenna described here by Dick Stroud, W9SR, is of interest to hams with limited space or who are portable operators. It has been used on 40, 80 and 160 meters. The antenna uses a single 10 foot TV mast section for the vertical radiator, along with a capacitance hat, loading coil, and short top mast. The overall height is less than 15 feet, as seen in **Figure 21.34**. The capacitance hat and loading coil assembly can be used with longer vertical radiators with changes to the coil inductance. A drawing showing complete dimensions and construction details is available with the online content.



Figure 21.34 — W9SR’s short vertical uses top loading and a capacitance hat with a 10 foot TV mast to make a compact antenna for 160, 80 or 40 meters.

CAPACITANCE HAT

The capacitance hat consists of a hub that mounts to the top mast above the coil and six elements made from aluminum rod. The machining, drilling, and tapping of the hub assembly can be done by nearly any machine shop if you don’t have the facilities. Be sure to use stainless steel hardware throughout. (Thanks to Fred Gantzer, W0AWD, for building the original hub.)



(A)

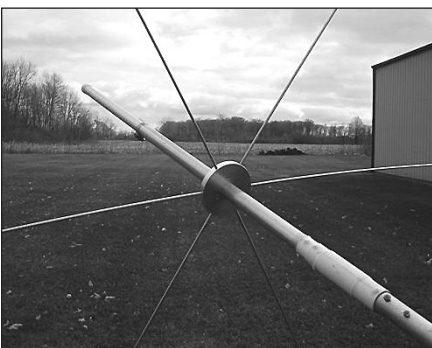

(B)

Figure 21.35 — The completed capacitance hat assembly is shown at A, and B shows a view of the upper mast assembly with the loading coil and capacitance hat.

The hub is made of two pieces of ½ inch thick aluminum as shown in Figure 21.35. The two pieces are bolted together to form the hub, which slides over the 1½ inch top mast. It is held in place with three 10-32 screws. The six elements of the capacitance hat are made from ⅜ inch aluminum rod, each 4.5 feet long. These are held in place with 6-32 screws.

LOADING COIL

The coil form is made from fiberglass tubing. A 6 inch length of 1.25 inch OD fiberglass tubing is centered over a 10 inch length of 1 inch OD tubing. The tubes telescope tightly, and it may be necessary to lightly sand the smaller tube for a smooth fit.

The loading coil is wound on the 1.25 inch OD fiberglass tube. After the coil is optimized, it is covered with a length of shrink sleeving for weather protection. Coil winding information in the drawing in the online content is for use with a 10 foot mast.

The bottom section of the coil assembly fits directly into the tapered upper section of the TV mast, and the exposed upper fiberglass section of the coil assembly fits into a 2.5 foot long, 1.125 inch OD, aluminum upper mast. Stainless 8-32 screws join the pieces together and also provide a connection point for the loading coil wires. If you use a painted steel mast, be sure to remove paint from the connection point, and then weather-seal it after adjustment is complete.

The capacitance hat hub slides over the upper mast and is held in place with three screws. The hub is about 6 inches above the coil, but the location can be moved to change the resonance of the antenna slightly.

The completed capacitance hat and loading coil assembly are shown in Figure 21.35. A dab of Glyptal (exterior varnish or Loctite also works) locks the screws in place once adjustments have been made, and the antenna is then ready for installation.

The coaxial feed line attaches to the bottom of the TV mast. Again, use an 8-32 screw for attachment and clean any paint from the metal. To match the antenna to a 50 Ω transmission line, a small parallel (shunt) inductance is needed at the base. The inductor is air-wound with #16 AWG wire (see Table 21.2).

Table 21.2
Shunt Inductor Winding Details

Frequency (MHz)	Turns
1.8	10 turns #16, spaced ⅛ inch
3.5	8.75 turns #16, spaced ⅛ inch
7	7.5 turns #16, spaced ⅛ inch

Note: All inductors are air wound, 1.75 inch ID. Dimensions shown are for use with 10 foot mast.

MOUNTING THE ANTENNA

A glass beverage bottle serves well as the base insulator, with the neck of the bottle fitting snugly into the TV mast. To support the base insulator, drill a hole large enough to accept the base of the bottle in the center of a 2 × 6 board about 14 inches long. Nail a piece of ¼ inch plywood over the bottom to keep the bottle from slipping through. To keep the base support board from moving around, drill a couple of holes and secure it to the ground with stakes.

The antenna is top-heavy and will need to be guyed. A simple insulated guy ring can be made from a 2 inch PVC coupling and placed on the mast just below the loading coil. The PVC is locked to the mast with three ¼-20 bolts. They are 1 inch long and have nuts on the inside and outside of the PVC. Three ¼ inch holes are drilled for the guy lines, made from lengths of ⅜ inch nonabsorbent rope.

OPERATION

On-air results with a 10 foot mast have been very good, even with low power. The ground system for the early tests was nothing more than an 8 foot ground rod hammered into the soil. With this setup, and using about 90 W, many DX contacts were made over one week’s time, and stateside contacts were plentiful.

There is plenty of room to experiment, however. Performance could be improved by using an extended radial system or raised and insulated radials. (Expect much better performance over average ground with a system of radials) Two, or even three, mast sections could be used with additional guys and proper loading coil inductance. If you use multiple masts, be sure to make a good electrical connection at the joints. The upper assembly is now permanently used to top load a 60 foot pole for transmitting on 160 meters.

21.3.4 Cables and Control Wires on Towers

Most vertical antennas of the type shown in Figure 21.32 and 21.33C-E consist of towers, usually with HF or VHF beam antennas at the top. The rotator control wires and the coaxial feeders to the top of the tower will not affect antenna performance adversely. In fact, they become a part of the composite antenna. To prevent unwanted RF currents from following the wires into the station, simply dress them close to the tower legs and bring them to ground level. (Running the cables inside the tower works even better.) This decouples the wires at RF. The wires should then be routed along the ground’s surface (or buried underground) to the operating position. It is not necessary to use bypass capacitors or RF chokes in the rotator control leads if this is done, even when maximum legal power is employed.

21.3.5 Multiband Trap Verticals

The two-band trap vertical antenna of **Figure 21.36** operates in much the same manner as a trap dipole or trap Yagi. The notable difference is that the vertical is one-half of a dipole. The radial system (in-ground or above-ground) functions as a ground plane for the antenna and provides an equivalent for the missing half of the dipole. Once again, the more effective the ground system, the better will be the antenna performance.

Trap verticals usually are designed to work as $\frac{1}{4} \lambda$ radiators. The portion of the antenna below the trap is adjusted as a $\frac{1}{4} \lambda$ radiator at the higher proposed operating frequency. That is, a 20/15 meter trap vertical would be a resonant quarter wavelength at 15 meters from the feed point to the bottom of the trap. The trap and that portion of the antenna above the trap (plus the 15 meter section below the trap) constitute the complete antenna during 20 meter operation. But because the trap is in the circuit, the overall physical length of the vertical antenna will be slightly less than that of a single-band, full-size 20 meter vertical.

“Ground-independent” multiband vertical antennas also have traps, but are designed to be electrically longer than $\frac{1}{4} \lambda$. A common electrical length is $\frac{3}{8} \lambda$, for example. The “traps” in these antennas are generally not parallel-LC circuits as described above. A variety of techniques are used with both parallel-LC traps and short resonant structures similar to stubs being used to change the antenna’s electrical length at different frequencies.

TRAPS

The trap functions as the name implies: the high impedance of the parallel resonant circuit “traps” the 15 meter energy and confines it to the part of the antenna below the trap. (See the **Electrical Fundamentals** chapter for more information on resonant LC circuits.) During

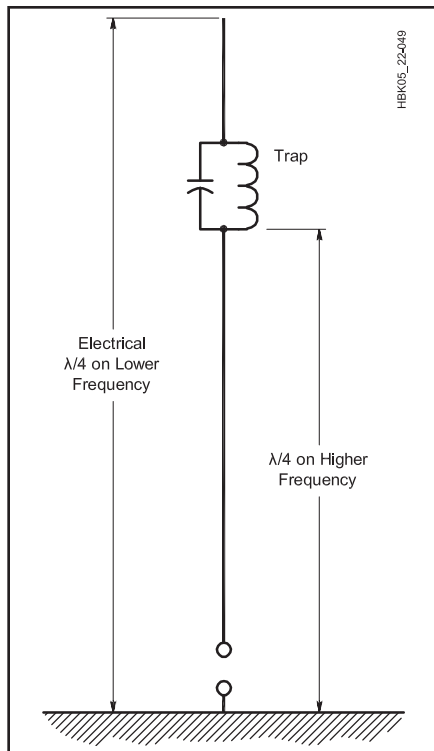

Figure 21.36 — A two-band trap vertical antenna. The trap should be resonated by itself as a parallel resonant circuit at the center of the operating range for the higher frequency band. The reactance of either the inductor or the capacitor range from 100 to 300 Ω. At the lower frequency the trap will act as a loading inductor, adding electrical length to the total antenna.

20 meter operation it allows the RF energy to reach all of the antenna. The trap in this example is tuned as a parallel resonant circuit to 21 MHz. At this frequency it electrically disconnects the top section of the vertical from the lower section because it presents a high impedance at 21 MHz, blocking 21 MHz current. Generally, the trap inductor and capaci-

tor have a reactance of 100 to 300 Ω. Within that range it is not critical.

The trap is built and adjusted separately from the antenna. It should be resonated at the center of the portion of the band to be operated. Thus, if one’s favorite part of the 15 meter band is between 21.0 and 21.1 MHz, the trap should be tuned to 21.05 MHz.

Resonance is checked by using a dip meter and detecting the signal in a calibrated receiver. An SWR analyzer can also be used. Once the trap is adjusted it can be installed in the antenna, and no further adjustment will be required. It is easy, however, to be misled after the system is assembled: Attempts to check the trap resonance in the antenna will suggest that the trap has moved much lower in frequency (approximately 5 MHz lower in a 20/15 meter vertical). This is because the trap is now part of the overall antenna, and the resultant resonance is that of the total antenna. Measure the trap’s resonant frequency separately from the rest of the antenna.

Multiband operation made quite practical by using the appropriate number of traps and tubing sections. The construction and adjustment procedure is the same, regardless of the number of bands covered. The highest frequency trap is always closest to the feed end of the antenna, and the lowest frequency trap is always the farthest from the feed point. As the operating frequency is progressively lowered, more traps and more tubing sections become a functional part of the antenna.

Traps should be weatherproofed to prevent moisture from detuning them. Several coatings of high dielectric compound are effective, such as polystyrene Q Dope or insulating varnish (see the article on weatherproofing by Dick Sander, K5QY, included with the online content). Alternatively, a protective sleeve of heat-shrink tubing can be applied to the coil after completion. The coil form for the trap should be of high insulating quality and rugged enough to sustain stress during periods of wind.

21.4 T and Inverted-L Antennas

The T and inverted L are variations on the vertical antenna. **Figure 21.37** shows a flat-top T vertical. The T is basically a shortened $\frac{1}{4} \lambda$ vertical with the flat-top T section acting as capacitive loading to length the antenna electrically. Dimension H should be as large as possible (up to $\frac{1}{4} \lambda$) for best results. The horizontal section, L, is adjusted to a length that provides resonance. Maximum radiation is polarized vertically despite the horizontal top-loading wire because current in each horizontal half creates out-of-phase radiation that cancels.

A variation of the T antenna is depicted in **Figure 21.38**. This antenna is commonly referred to as an *inverted-L* and is basically a $\frac{5}{16} \lambda$ vertical bent in the middle so that the top

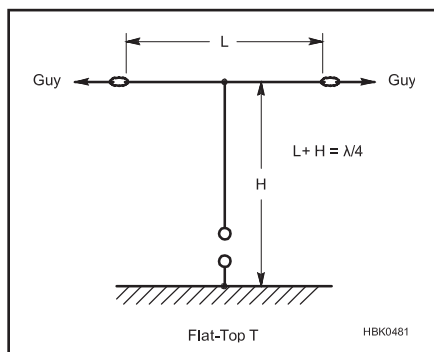

Figure 21.37 — The T antenna is basically a shortened $\frac{1}{4} \lambda$ vertical with the flat-top T section acting as capacitive loading to length the antenna electrically.

section runs parallel to the ground. As with the T antenna, the vertical section should be as long as possible. L is then added to provide an electrical $\frac{5}{16} \lambda$ overall.

Because the horizontal section does carry some current, there will be some horizontally polarized radiation at high angles. This is often considered desirable because it provides local and regional coverage. The horizontal section need not be perfectly horizontal — sloping the wire at a shallow angle from horizontal does not greatly affect antenna performance. This allows the inverted-L to be constructed with a single vertical support.

A sidearm or a length of line attached to a tower can be used to support the vertical

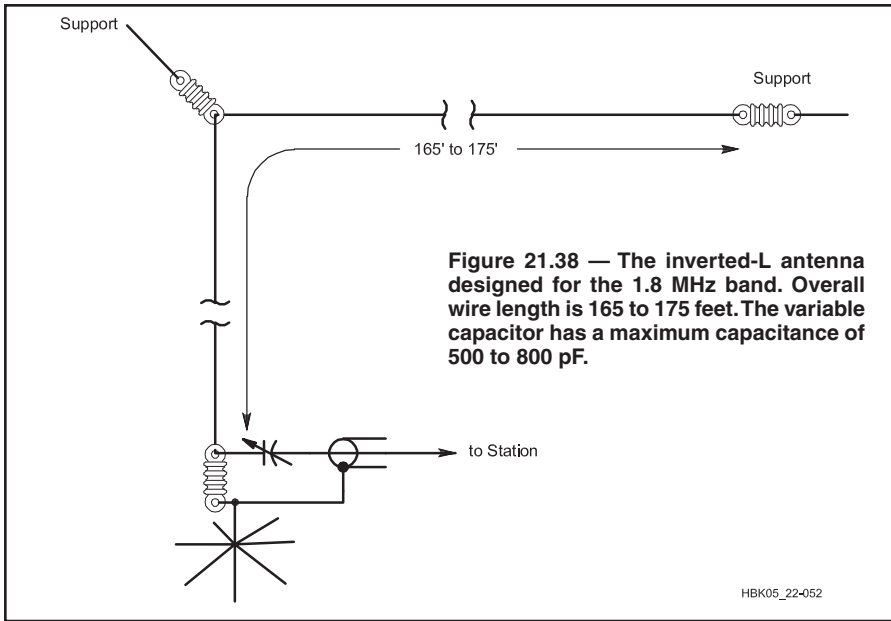

Figure 21.38 — The inverted-L antenna designed for the 1.8 MHz band. Overall wire length is 165 to 175 feet. The variable capacitor has a maximum capacitance of 500 to 800 pF.

section of the T or inverted-L antenna. (Keep the vertical section of the antennas as far from the tower as is practical. Certain combinations of tower height and top loading can create a resonance that interacts severely with the antennas — a 70 foot tower and a 5-element

Yagi, for example.)

Both the T and inverted-L are ground-plane antennas and require a good ground system to be effective. If the T or inverted-L are used with a very good ground system, the feed-point impedance will approach 35 to 40 Ω

Table 21.3

Inverted-L Dimensions for 50- Ω Feed Point Impedance at 1.82 MHz

Vertical Height (m)	Horizontal Length (m)	Inductive Reactance (Ω)	Capacitance Required (pF)
10	59.9	1238	71
20	39.7	517	169
30	21	235	372

Results modeled by EZNEC 5.0 over real ground. Capacitance specified as series value to cancel inductive reactance.

so that the SWR approaches 1.4:1. The inverted-L or T can be constructed to be longer than needed for resonance as illustrated in Figure 21.38. This increases the feed point resistance to 50 Ω plus some inductive reactance due to the extra length. A series capacitor at the feed point then cancels the reactance, leaving a 50 Ω impedance suitable for direct connection by coaxial cable. **Table 21.3** provides values of capacitance for some combinations of vertical and horizontal height. A transmitting variable capacitor is recommended to allow the impedance match to be tuned.

21.5 Slopers and Vertical Dipoles

21.5.1 Half-Sloper Antenna

Many hams have had excellent results with *half-sloper* antennas, while others have not had such luck. Investigations by ARRL Technical Advisor John S. Belrose, VE2CV, have brought some insight to the situation through computer modeling and antenna-range tests. The following is taken from VE2CV's Technical Correspondence in Feb 1991 *QST*, pp. 39 and 40. Essentially, the half-sloper is a top-fed vertical antenna that uses the structure at the top of the tower plane (such as a grounded Yagi antenna) as a ground plane and the tower acts as a reflector (see **Figure 21.39**).

For half-slopers, the input impedance, the resonant length of the sloping wire and the antenna pattern all depend on the tower height, the angle (between the sloper and tower), the type of Yagi, and the Yagi orientation. Here are several configurations extracted from VE2CV's work:

At 160 meters — a 40 meter beam on top of a 95 foot tower with a 55° sloper apex angle. The radiation pattern varies little with Yagi type. The pattern is slightly cardioid with about 8 dB front-to-back ratio at a 25° takeoff angle

(see Figure 21.39B and C). Input impedance is about 50 Ω .

At 80 meters — a 20 meter beam on top of a 50 foot tower with a 55° sloper apex angle. The radiation pattern and input impedance are similar to those of the 160 meter half-sloper.

At 40 meters — a 20 meter beam on top of a 50 foot tower with a 55° sloper apex angle. The radiation pattern and impedance depend strongly on the azimuth orientation of the Yagi. Impedance varies from 76 to 127 Ω depending on Yagi direction.

There are many configurations that will produce a reasonable feed point impedance and acceptable radiation pattern. Experimentation is usually required to find a design that works for a particular installation.

21.5.2 Half-Wave Vertical Dipole

Unlike its horizontal counterpart, which has a figure-8 pattern, the azimuthal pattern of a vertical dipole is omnidirectional. Look again at Figures 21.7 and 21.8 and note the comparison between horizontal and vertical dipole elevation patterns. These two figures illustrate

the fact that performance of a horizontal dipole depends to a great extent on its height above ground. By contrast, *half-wave vertical dipole (HVD)* performance is highly dependent on ground conductivity and dielectric constant.

Experiments by K8CH show that an HVD can compete favorably with horizontal dipole or inverted-V antennas at a similar height. The HVD only requires one main support (see the caution below on feed line orientation), which makes it a good choice for portable or temporary operation.

Figure 21.40 shows the elevation patterns for the vertical dipole and for the reference dipole at a pattern peak and at a null. The large lobe in the HVD pattern at 48° is caused by the antenna being elevated 14 feet above ground. This lobe will shrink at lower heights. The patterns of both antennas depend strongly on antenna height.

One challenge to building the HVD is feed line decoupling. The feed line attached in the middle must be routed away from the antenna at right angles to prevent excessive shield current from distorting the antenna's pattern, even if a choke balun is used. This can be mechanically challenging.

Figure 21.39 — The half-sloper antenna (A). B is the vertical radiation pattern in the plane of a half sloper, with the sloper to the right. C is the azimuthal pattern of the half sloper (90° azimuth is the direction of the sloping wire). Both patterns apply to 160 and 80 meter antennas described in the text.

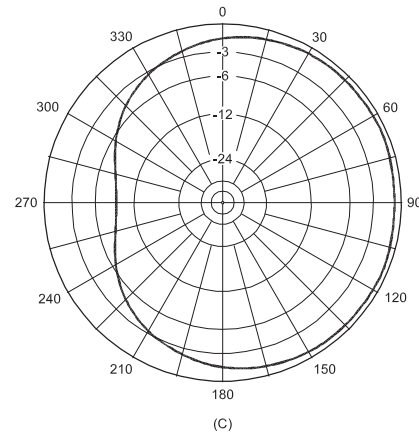
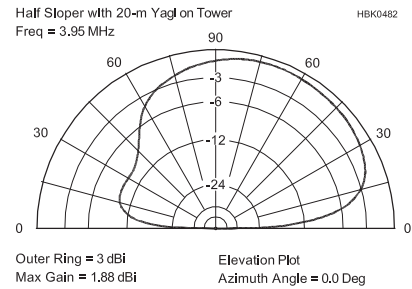
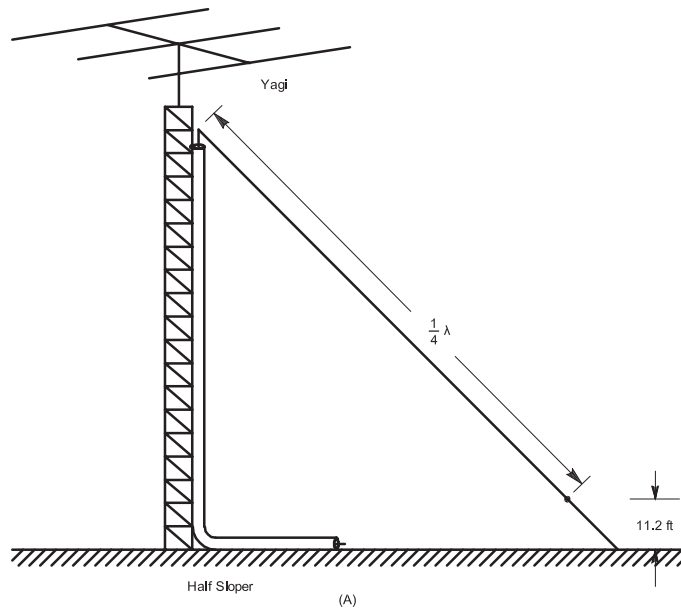

Project: Half-Wave Vertical Dipole (HVD)

Chuck Hutchinson, K8CH, describes a 15 meter vertical dipole (HVD) that he built for the ARRL book, *Simple and Fun Antennas for Hams*. The performance of this antenna, with its base at 14 feet, compares favorably with a horizontal dipole at 30 feet when making intercontinental QSOs.

CONSTRUCTION OF A 15 METER HVD

The 15 meter HVD consists of four 6 foot lengths of 0.875 inch aluminum tube with 0.058 wall thickness. In addition there are two 1 foot lengths of 0.75 inch tubing for splices, and two 1 foot lengths of 0.75 inch fiberglass rod for insulators (see **Table 21.4** for dimensions).

Start by cutting off 1 foot from a 6 foot length of 0.875 inch tubing. Next, insert six inches of one of the 1-foot-long 0.75 inch tubes into the machine-cut end of your tubing and fasten the tubes together using sheet metal screws or pop rivets. Now, slide an end of a 6 foot length of 0.875 inch tube over the protruding end of the 0.75 inch tube and fasten them together. Repeat this procedure with the remaining 0.875 inch tubing. You should now have two 11-foot-long sections.

Because handmade cuts are not perfectly square, put those element ends at the center of the antenna. Slip these cut ends over the ends of a 1 foot length of 0.75 inch fiberglass

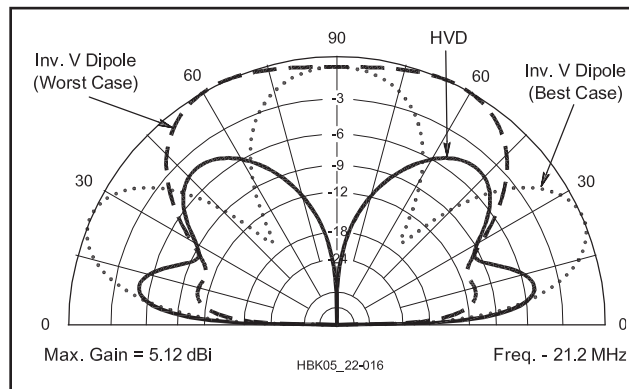

Figure 21.40 — Elevation patterns for the HVD (solid line) and the inverted-V comparison antenna in its best case (dotted line) and worst case (dashed line).

rod. This rod serves as the center insulator. Leave about a 1 inch gap at the center. Drill aluminum and fiberglass for #8 hardware as shown in **Figure 21.41**.

Now, slip half of the remaining 1 foot length of 0.75 inch fiberglass rod into one end of the

dipole. (This end will be the bottom end or base.) Drill and secure with #8 hardware (see **Figure 21.42**).

The final step is to secure the guy wires to your vertical. You can see how K8CH did that in **Figure 21.43**. Start by drilling a pilot hole and then drive a sheet metal screw into the antenna about a foot above the center. The purpose of that screw is to prevent the clamp and guys from sliding down the antenna.

The guys are continuous lengths of 3/16 inch Dacron line. (The Dacron serves a dual purpose: it supports the antenna vertically, and it acts as an insulator.) Tie secure knots into the guy ends and secure these knotted ends to the antenna with a stainless-steel worm-screw-type hose clamp. Take care to not over tighten the clamps. You don't want the clamp to slip

Table 21.4

HVD Dimensions

Length using 0.875-inch aluminum tubing

MHz	Feet	Inches
18.11	33	11
21.2	22	0
24.94	18	9
28.4	16	5

These lengths should be divided by two to determine the length of the dipole legs.

(the knots and the sheet-metal screw will help), but you especially don't want to cut your guy lines. Your antenna is ready for installation.

INSTALLATION

Installation requires two things. First, a place to sit or mount the base insulator. Second,

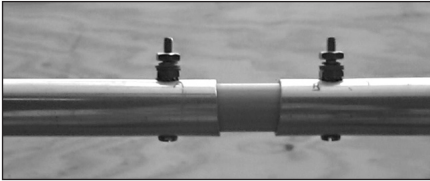

Figure 21.41 — The center insulator of the 15 meter HVD is a 1 foot length of 0.75 inch fiberglass rod. Insulator and elements have been drilled to accept #8 hardware.

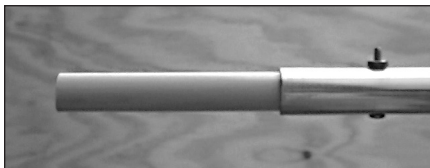

Figure 21.42 — The HVD base insulator is a 1 foot length of 0.75 inch fiberglass rod.

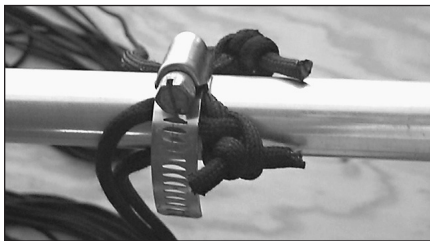

Figure 21.43 — Guys are made of Dacron line that is attached to the HVD by a stainless-steel worm-screw-type hose clamp. A self-tapping sheet-metal screw (not visible in the photo) prevents the clamp from sliding down the antenna.



Figure 21.44 — At K8CH, the HVD base insulator sits in this saddle-shaped wooden fixture. This was photo was taken before the fixture was painted — a necessary step to protect against the weather.

you need anchors for the support guys.

K8CH used a piece of 2 × 6 lumber to make a socket to hold the HVD base securely in place. He drilled a ¾ inch-deep hole with a ¾ inch spade bit. A couple of pieces of 2 × 2 lumber at the ends of the base form a saddle that nicely straddles the ridge at the peak of his garage roof. You can see this in **Figure 21.44**. The dimensions are not critical. Paint your base to protect it from the weather.

BALUN

This antenna needs a common-mode choke balun to ensure that RF doesn't flow on the shield of the coax. (See the **Transmission Lines** chapter for more information on choke baluns.) Unlike a horizontal dipole, don't consider it an option to omit the common-mode choke when building and installing an HVD.

You can use 8 feet of the RG-213 feed line wound into 7 turns for a balun. Secure the turns together with electrical tape so that each turn lies parallel with the next turn, forming a solenoid coil. Secure the feed line and balun to one of the guy lines with UV-resistant cable ties.

Because the feed line slants away from the antenna, you'll want to do *all* that you can to eliminate common-mode currents from the feed line. For that reason, make another balun about 11.5 feet from the first one. This balun also consists of 8 feet of the RG-213 feed line wound into 7 turns. See **Figure 21.45** for a photo of the installed antenna.

Project: Compact Vertical Dipole (CVD)

An HVD for 20 meters will be about 33 feet tall, and for 30 meters it will be around 46 feet tall. Even the 20 meter version can prove to be a mechanical challenge. The compact vertical dipole (CVD), designed by Chuck Hutchinson, K8CH, uses capacitance loading to shorten the antenna. Starting with the 15 meter HVD described in the previous project, Chuck added capacitance loading wires to lower the resonance to 30 meters. Later, he shortened the wires to move resonance to the 20 meter band. This project describes those two CVDs.

PERFORMANCE ISSUES

Shortened antennas frequently suffer reduced performance caused by the shortening. A dipole that is less than ½ λ in length is a compromise antenna. The issue becomes how much is lost in the compromise. In this case there are two areas of primary interest, radiation efficiency and SWR bandwidth.

Radiation Efficiency

Capacitance loading at the dipole ends is the most efficient method of shortening the antenna. Current distribution in the high-



Figure 21.45 — The HVD installed at K8CH. An eye screw that is used for securing one of the guy lines is visible in the foreground. You can also see the two choke baluns that are used in the feed system (see text).

current center of the antenna remains virtually unchanged. Since radiation is related directly to current, this is the most desirable form of loading. Computer modeling shows that radiation from a 30 meter CVD is only 0.66 dB less than that from a full-size 30 meter HVD when both have their bases 8 feet above ground. The angle of maximum radiation shifts up a bit for the CVD. Not a bad compromise when you consider that the CVD is 22 feet long compared to the approximately 46 foot length of the HVD.

SWR and SWR Bandwidth

Shortened antennas usually have lower radiation resistance and less SWR bandwidth than the full-size versions. The amount of change in the radiation resistance is related to the amount and type of loading (shortening) being lower with shorter antennas. This can be a benefit in the case of a shortened vertical dipole. In **Figure 21.2** you can see that vertical dipoles have a fairly high radiation resistance. With the dipole's lower end ⅛ λ above ground, the radiation resistance is roughly 80 Ω. In this case, a shorter antenna can have a better SWR when fed with 50 Ω coax.

SWR bandwidth tends to be wide for vertical dipoles in general. A properly designed CVD for 7 MHz or higher should give you good SWR (1.5:1 or better) across the entire band!

As you can see, in theory the CVD provides

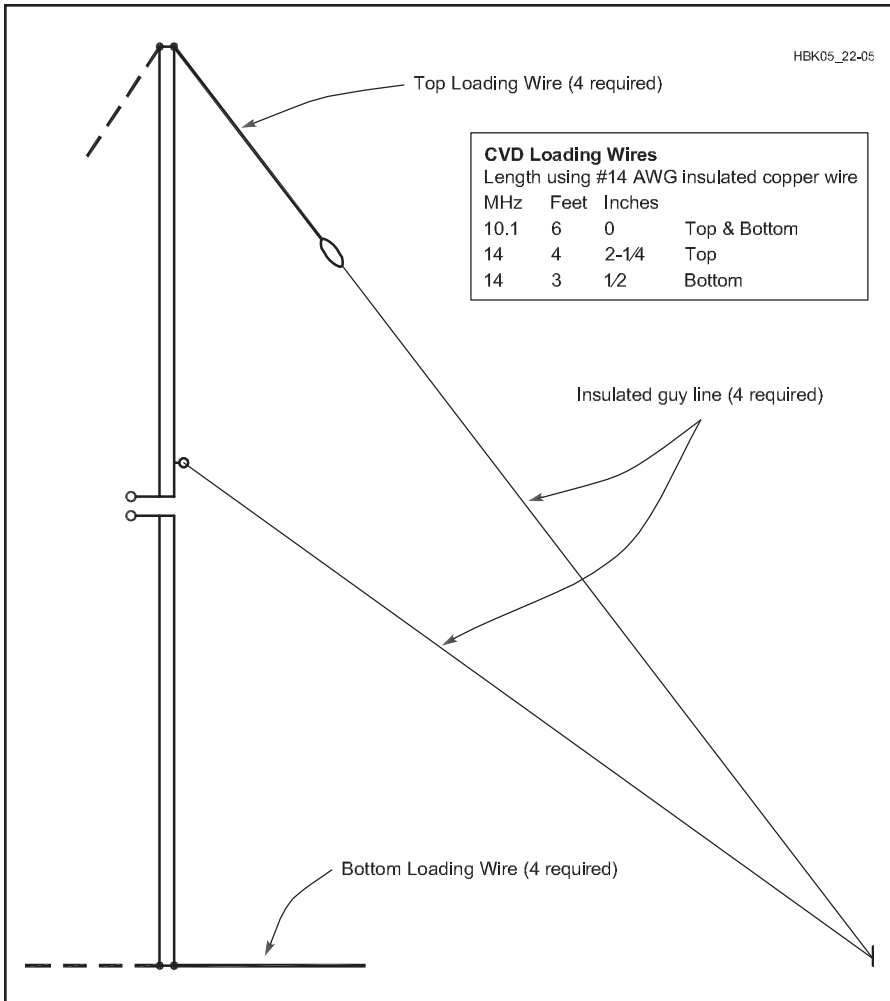

Figure 21.46 — The CVD consists of a vertical dipole and loading wires. Only one set of the four loading wires and only one guy line is shown in this drawing. See text for details.

excellent performance in a compact package. Experience confirms the theory.

CONSTRUCTION

To convert the K8CH 15 meter HVD to 20 or 30 meters, you'll need to add four loading wires at the top and four more at the bottom of the HVD. The lengths are given in the table in **Figure 21.46**. The upper wires droop at a 45° angle and the lower wires run horizontally. The antenna is supported by four guy lines. You can connect the wires to the vertical portion with #8 hardware. Crimp and solder terminals on the wire ends to make connections easier. The technique is illustrated in **Figure 21.47**.

The upper loading wires can be extended with insulated line and used for additional guying. The lower wires are extended with insulated line and fasten to the guy lines so that the lower wires run horizontally.

Prune the lower wires for best SWR across the band of interest. The K8CH CVD has its base at 14 feet. This antenna has an SWR of

less than 1.2:1 on 30 meters and less than 1.3:1 across the entire 20 meter band.

EXPERIENCE

The 30 meter CVD was compared to a ground-mounted quarter-wave vertical and a horizontal dipole at 30 feet. In tests, the CVD was always the superior antenna.

Later, the CVD loading wires were shortened for operation on 20 meters. Once again the results were very encouraging.

Project: All-Wire 30 Meter CVD

If you have a tree or other support that will support the upper end of a CVD at 32 feet above the ground, you might want to consider an all-wire version of the 30 meter CVD. The vertical is 24 feet long, and it will have an SWR of less than 1.1:1 across the band. The four loading wires at top and bottom are each 5 feet, 2 inches long.

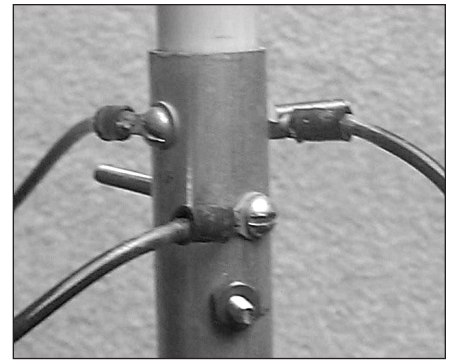

Figure 21.47 — CVD loading wires can be attached using #8 hardware. Crimp and solder terminals on the wire ends to make connections easier.

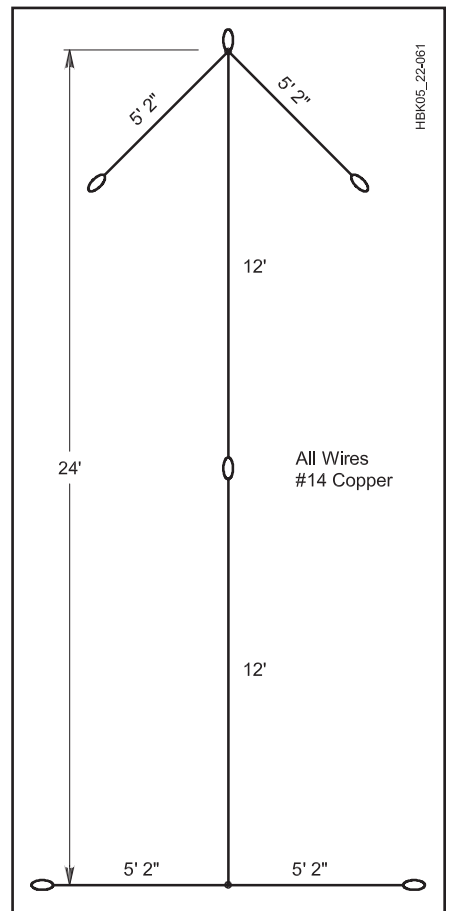

Figure 21.48 — The all-wire 30 meter CVD consists of a vertical dipole and loading wires. It can be made entirely with #14 AWG wire. Support lines have been omitted for simplicity. See text for details.

The configuration is shown in **Figure 21.48**. As with any vertical dipole, you'll need to use a balun between the feed line and the antenna.

Alternatively you can use two loading wires at the top and two at the bottom. In this case each of the loading wires is 8 feet, 7.5 inches long.

21.6 Yagi Antennas

Most antennas described earlier in this chapter have unity gain compared to a dipole, or just slightly more. For the purpose of obtaining gain and directivity it is convenient to use a Yagi-Uda beam antenna. The former is commonly called a *Yagi*. There are other forms of directive antennas, but the Yagi is by far the most popular used by amateurs. (For more information on phased arrays and other types of directive antennas, see the *ARRL Antenna Book*.)

Most operators prefer to erect these antennas for horizontal polarization, but they can be used as vertically polarized antennas merely by rotating the elements by 90°. In effect, the beam antenna is turned on its side for vertical polarization. The number of elements used will depend on the gain desired and the limits of the supporting structure. At HF, many amateurs obtain satisfactory results with only two elements in a beam antenna, while others have four or five elements operating on a single amateur band, called a *monoband beam*. On VHF and above, Yagis with many elements are common, particularly for simplex communication without repeaters. For fixed point-to-point communications such as repeater links, Yagis with three or four elements are more common.

Regardless of the number of elements used, the height-above-ground considerations discussed earlier for dipole antennas remain valid with respect to the angle of radiation. This is demonstrated in **Figure 21.49** at A and B where a comparison of radiation characteristics is given for a 3 element Yagi at one-half and one wavelength above average ground. It can be seen that the higher antenna (Figure 21.49B) has a main lobe that is more favorable for DX work (roughly 15°) than the lobe of the lower antenna in Figure 21.49A (approximately 30°). The pattern at B shows that some useful high-angle radiation exists also, and the higher lobe is suitable for short-skip contacts when propagation conditions dictate the need.

The azimuth pattern for the same antenna is provided in **Figure 21.50**. (This is a free-space pattern, so the pattern is taken in the plane of the antenna. Remember that azimuth patterns taken over a reflecting surface must also specify the elevation angle at which the pattern was measured or calculated.) Most of the power is concentrated in the main lobe at 0° azimuth. The lobe directly behind the main lobe at 180° is often called the *back lobe* or *rear lobe*. The front-to-back ratio (F/B) of this antenna is just less than 12 dB — the peak power difference, in decibels, between the main lobe at 0° and the rearward lobe at 180°. It is infrequent that two 3 element Yagis with different element spacing and tuning will yield the same lobe patterns. The patterns also change with frequency of operation. The pattern of Figure 21.50 is shown only for illustrative purposes.

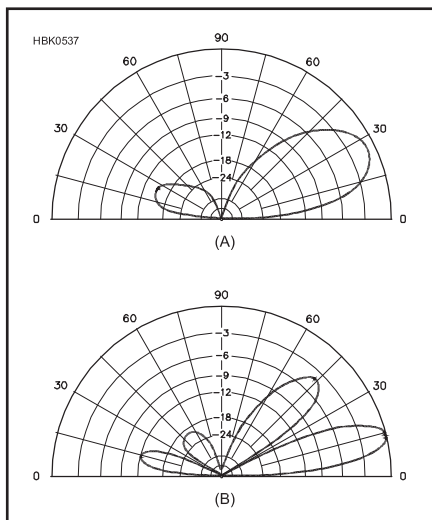

Figure 21.49 — Elevation-plane response of a 3 element Yagi placed $\frac{1}{2} \lambda$ above perfect ground at A and the same antenna spaced 1λ above ground at B.

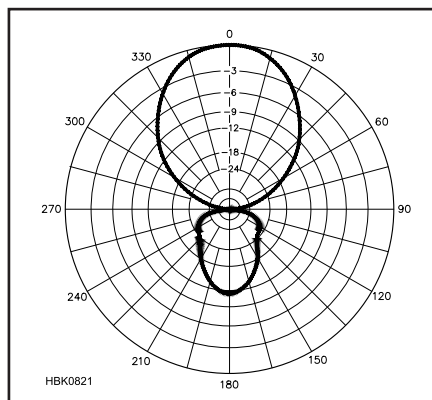

Figure 21.50 — Azimuthal pattern of a typical three-element Yagi in free space. The Yagi's boom is along the 0° to 180° axis.

21.6.1 Parasitic Excitation

In a Yagi antenna only one element (the *driven element*) is connected to the feed line. The additional elements are *coupled* to the driven element because they are so close. (Element-to-element spacing in a Yagi antenna is generally on the order of $\frac{1}{10}$ to $\frac{1}{8}$ wavelength.) This *mutual coupling* results in currents being induced in the non-driven elements from the radiated field of the driven element. These elements are called *parasitic elements*, and the Yagi antenna is therefore a *parasitic array*. (An antenna in which multiple elements all receive power from the transmitter is called a *driven array*.) The currents induced in the parasitic elements also result in radiated

fields, just as if the current were the result of power from a feed line. This is called *re-radiation*, and it has a 180° phase shift from the current-inducing field. The combination of the field radiated by the driven element, the fields from the parasitic elements, and the physical spacing of the elements results in the fields having the proper phase relationship so as to focus the radiated energy in the desired direction and reject it in other directions.

The parasitic element is called a *director* when it reinforces radiation along a line pointing to it from the driven element, and a *reflector* in the opposite case. Whether the parasitic element is a director or reflector depends on the parasitic element tuning, which is usually adjusted by changing its length. The structure on which the elements are mounted is called the *boom* of the antenna.

21.6.2 Yagi Gain, Front-to-Back Ratio, and SWR

The gain of a Yagi antenna with parasitic elements varies with the spacing and tuning of the elements. Element tuning is a function of length, diameter, and *taper schedule* (the steps in length and diameter) if the element is constructed with telescoping tubing. For any given number of elements and the spacing between them, there is a tuning condition that will result in maximum gain. However, the maximum front-to-back ratio seldom, if ever, occurs at the same condition that gives maximum forward gain. The impedance of the driven element in a parasitic array, and thus the SWR, also varies with the tuning and spacing.

It is important to remember that all these parameters change as the operating frequency is varied. For example, if you operate both the CW and phone portions of the 20 meter band with a Yagi antenna, you probably will want an antenna with consistent performance over most of the band. Such designs typically must sacrifice a little gain in order to achieve good F/B and SWR performance across the band.

Gain and F/B performance generally improve with the number of elements. In Yagi antennas with more than three elements (a driven element and one director and reflector), the additional elements are added as directors, since little additional benefit is obtained from multiple reflectors. Wider spacing also improves gain and F/B up to a certain point, depending on a number of factors, beyond which performance begins to fall. Optimizing element spacing is a complex problem, and no single spacing satisfies all design requirements. For the lower HF bands, the size of the antenna quickly becomes impractical for truly *optimal* designs, and compromise is necessary.

OWA Designs

The Optimized Wideband Antenna (OWA) was originally developed by Jim Breakall,

WA3FET. It is a matching method that increases feed point impedance and widens the VSWR bandwidth. It can be applied to dipoles and monopoles, but it is most widely used for monoband Yagi designs. (The technique is described in more detail at www.naic.edu/~angel/kp4ao/ham/owa.html.)

A parasitic element placed ahead of and very close (less than 0.01 wavelength) to a driven element results in wide-band performance. That is, a low SWR relative to 50 Ω, smooth gain, and front-to-back performance over a wide HF amateur band (such as 20, 15, or 10 meters). The developers of the antenna suggest that the driver and first director perform as if they were a single element having a diameter equal to the spacing between the two elements.

The OWA is implemented in a Yagi antenna by placing the first director 0.05 λ in front of (in the forward direction) the driven element. By raising the feed point impedance to 50 Ω, coaxial feed lines can be attached directly using a simple 1:1 choke balun. This eliminates the more complex gamma or beta matching systems used to match the low impedance of most Yagi antennas.

OWA Yagis give up a small amount of forward gain, typically less than 0.5 dB, from the lower-impedance designs. This is rarely significant in regular operation and is a good trade-off for the simplicity of direct feed and improved bandwidth.

21.6.3 Two-Element Beams

A two-element beam is useful — especially where space or other considerations prevent the use of a three-element, or larger, beam. The general practice is to tune the parasitic element as a reflector and space it about 0.15 λ from the driven element, although some successful antennas have been built with 0.1-λ spacing and director tuning.

Gain vs. element spacing for a two-element antenna is given in **Figure 21.51** for the special case where the parasitic element is

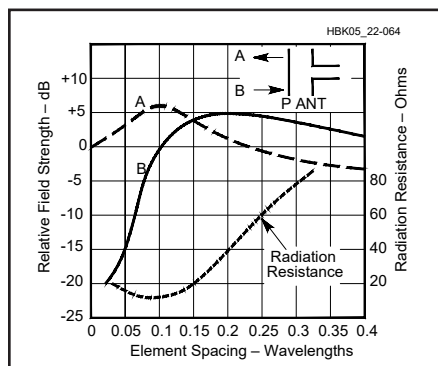

Figure 21.51 — Gain vs element spacing for a two-element Yagi, having one driven and one parasitic element. The reference point, 0 dB, is the field strength from a half-wave antenna alone.

resonant. It is indicative of the performance to be expected under maximum-gain tuning conditions. Changing the tuning of the driven element in a Yagi or quad will not materially affect the gain or F/R. Thus, only the spacing and the tuning of the single parasitic element have any effect on the performance of a 2 element Yagi.

In **Figure 21.51**, the greatest gain is in the direction A (in which the parasitic element is acting as a director) at spacings of less than 0.14 λ, and in direction B (in which the parasitic element is a reflector) at greater spacings. The front-to-back ratio is the difference in decibels between curves A and B along the boom of the antenna. The figure also shows variation in radiation resistance of the driven element.

These curves are for the special case of a self-resonant parasitic element, but are representative of how a two-element Yagi works. At most spacings the gain as a reflector can be increased by slight lengthening of the parasitic element; the gain as a director can be increased by shortening. This also improves the front-to-rear ratio.

Most two-element Yagi designs achieve a compromise F/R of about 10 dB, together with an acceptable SWR and gain across a frequency band with a percentage bandwidth less than about 4%.

21.6.4 Three-Element Beams

A theoretical investigation of the three-element case (director, driven element, and reflector) has indicated a maximum gain of about 9.7 dBi (7.6 dBd). A number of experimental investigations have shown that the spacing between the driven element and reflector for maximum gain is in the region of 0.15 to 0.25 λ. With 0.2 λ reflector spacing, **Figure 21.52** shows that the gain variation with director spacing is not especially critical. Also, the overall length of the array (boom length in the case of a rotatable antenna) can be anywhere between 0.35 and 0.45 λ with no appreciable difference in the maximum gain obtainable.

If maximum gain is desired, wide spacing

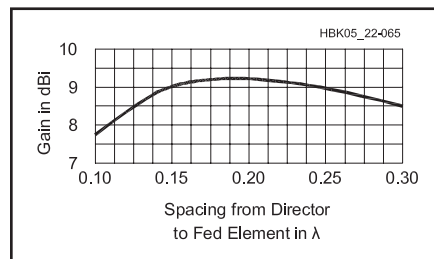

Figure 21.52 — General relationship of gain of three-element Yagi vs. director spacing, the reflector being fixed at 0.2 λ. This antenna is tuned for maximum forward gain.

of both elements is beneficial because adjustment of tuning or element length is less critical and the input resistance of the driven element is generally higher than with close spacing. A higher input resistance improves the efficiency of the antenna and makes a greater bandwidth possible. However, a total antenna length, director to reflector, of more than 0.3 λ at frequencies of the order of 14 MHz introduces difficulty from a construction standpoint. Lengths of 0.25 to 0.3 λ are therefore used frequently for this band, even though they are less than optimum from the viewpoint of maximum gain.

In general, Yagi antenna gain drops off less rapidly when the reflector length is increased beyond the optimum value than it does for a corresponding decrease below the optimum value. The opposite is true of a director. It is therefore advisable to err, if necessary, on the long side for a reflector and on the short side for a director. This also tends to make the antenna performance less dependent on the exact frequency at which it is operated. An increase above the design frequency has the same effect as increasing the length of both parasitic elements, while a decrease in frequency has the same effect as shortening both elements. By making the director slightly short and the reflector slightly long, there will be a greater spread between the upper and lower frequencies at which the gain starts to show a rapid decrease.

21.6.5 Construction of Yagi Antennas

Most beams and verticals are made from sections of aluminum tubing. Compromise beams have been fashioned from less-expensive materials such as electrical conduit (steel) or bamboo poles wrapped with conductive tape or aluminum foil. The steel conduit is heavy, is a poor conductor, and is subject to rust. Similarly, bamboo with conducting material attached to it may deteriorate rapidly in the weather. Given the drawbacks of alternative materials, aluminum tubing (or rod for VHF and UHF Yagis) is far and away the best choice for antenna construction.

For reference, **Table 21.5** details the standard sizes of aluminum tubing, available in many metropolitan areas. Metal distributors, local and online, usually stock popular sizes of aluminum tubing. Several *QST* advertisers stock an extensive line of tubing specifically for antenna construction and cut to shippable lengths. Tubing usually comes in 12 foot lengths, although 20 foot lengths are available in some sizes. Your aluminum dealer will probably also sell aluminum plate in various thicknesses needed for boom-to-mast and boom-to-element connections.

Aluminum is rated according to its hardness. The most common material used in antenna

Table 21.5
Standard Sizes of Aluminum Tubing

6061-T6 (61S-T6) Round Aluminum Tube in 12-ft Lengths

OD (in)	Wall Thickness		ID (in)	Approx Weight (lb)		OD (in)	Wall Thickness		ID (in)	Approx Weight (lb)	
	(in)	stubs ga		per ft	per length		(in)	stubs ga		per ft	per length
3/16	0.035	no. 20	0.117	0.019	0.228	1 1/4	0.035	no. 20	1.180	0.155	1.860
	0.049	no. 18	0.089	0.025	0.330		0.049	no. 18	1.152	0.210	2.520
1/4	0.035	no. 20	0.180	0.027	0.324	1 1/2	0.058	no. 17	1.134	0.256	3.072
	0.049	no. 18	0.152	0.036	0.432		0.065	no. 16	1.120	0.284	3.408
	0.058	no. 17	0.134	0.041	0.492		0.083	no. 14	1.084	0.357	4.284
5/16	0.035	no. 20	0.242	0.036	0.432	1 3/8	0.035	no. 20	1.305	0.173	2.076
	0.049	no. 18	0.214	0.047	0.564		0.058	no. 17	1.259	0.282	3.384
	0.058	no. 17	0.196	0.055	0.660	1 1/2	0.035	no. 20	1.430	0.180	2.160
3/8	0.035	no. 20	0.305	0.043	0.516	1 3/4	0.049	no. 18	1.402	0.260	3.120
	0.049	no. 18	0.277	0.060	0.720		0.058	no. 17	1.384	0.309	3.708
	0.058	no. 17	0.259	0.068	0.816		0.065	no. 16	1.370	0.344	4.128
	0.065	no. 16	0.245	0.074	0.888		0.083	no. 14	1.334	0.434	5.208
7/16	0.035	no. 20	0.367	0.051	0.612	1 5/8	*0.125	1/8"	1.250	0.630	7.416
	0.049	no. 18	0.339	0.070	0.840		*0.250	1/4"	1.000	1.150	14.823
	0.065	no. 16	0.307	0.089	1.068		1 3/4	0.035	no. 20	1.555	0.206
1/2	0.028	no. 22	0.444	0.049	0.588	1 7/8	0.058	no. 17	1.509	0.336	4.032
	0.035	no. 20	0.430	0.059	0.708		1 3/4	0.058	no. 17	1.634	0.363
	0.049	no. 18	0.402	0.082	0.948	1 7/8	0.083	no. 14	1.584	0.510	6.120
	0.058	no. 17	0.384	0.095	1.040		0.508	no. 17	1.759	0.389	4.668
	0.065	no. 16	0.370	0.107	1.284		2	0.049	no. 18	1.902	0.350
5/8	0.028	no. 22	0.569	0.061	0.732	2 1/4	0.065	no. 16	1.870	0.450	5.400
	0.035	no. 20	0.555	0.075	0.900		0.083	no. 14	1.834	0.590	7.080
	0.049	no. 18	0.527	0.106	1.272		*0.125	1/8"	1.750	0.870	9.960
	0.058	no. 17	0.509	0.121	1.452		*0.250	1/4"	1.500	1.620	19.920
	0.065	no. 16	0.495	0.137	1.644		2 1/2	0.049	no. 18	2.152	0.398
3/4	0.035	no. 20	0.680	0.091	1.092	2 1/2	0.065	no. 16	2.120	0.520	6.240
	0.049	no. 18	0.652	0.125	1.500		0.083	no. 14	2.084	0.660	7.920
	0.058	no. 17	0.634	0.148	1.776		0.065	no. 16	2.370	0.587	7.044
	0.065	no. 16	0.620	0.160	1.920	0.083	no. 14	2.334	0.740	8.880	
	0.083	no. 14	0.584	0.204	2.448	*0.125	1/8"	2.250	1.100	12.720	
7/8	0.035	no. 20	0.805	0.108	1.308	3	*0.250	1/4"	2.000	2.080	25.440
	0.049	no. 18	0.777	0.151	1.810		0.065	no. 16	2.870	0.710	8.520
	0.058	no. 17	0.759	0.175	2.100		*0.125	1/8"	2.700	1.330	15.600
	0.065	no. 16	0.745	0.199	2.399		*0.250	1/4"	2.500	2.540	31.200
1	0.035	no. 20	0.930	0.123	1.467	*These sizes are extruded; all other sizes are drawn tubes. Shown here are standard sizes of aluminum tubing that are stocked by most aluminum suppliers or distributors in the United States and Canada. Don Daso, K4ZA, explains the different aluminum alloy types in this book's online article "Workshop Chronicles: Alloy Designations."					
	0.049	no. 18	0.902	0.170	2.040						
	0.058	no. 17	0.884	0.202	2.424						
	0.065	no. 16	0.870	0.220	2.640						
	0.083	no. 14	0.834	0.281	3.372						
1 1/8	0.035	no. 20	1.055	0.139	1.668						
	0.058	no. 17	1.009	0.228	2.736						

construction is grade 6061-T6. This material is relatively strong and has good workability. In addition, it will bend without taking a set, an advantage in antenna applications where the pieces are constantly flexing in the wind. The softer grades (5051, 3003, and so on) will bend much more easily, while harder grades (7075 and so on) are more brittle.

Wall thickness is of primary concern when selecting tubing. It is of utmost importance that the tubing fits snugly where the element sections join. Sloppy joints will make a mechanically unstable antenna. The magic wall thickness is 0.058 inch. For example (from Table 21.5), 1 inch outside diameter (OD) tubing with a 0.058 inch wall has an inside

diameter (ID) of 0.884 inch. The next smaller size of tubing, 7/8 inch, has an OD of 0.875 inch. The 0.009 inch difference provides just the right amount of clearance for a snug fit.

Figure 21.53 shows several methods of fastening antenna element sections together. The slot and hose clamp method shown at the upper left is probably the best for joints where adjustments are needed. Generally, one adjustable joint on each side of the element is sufficient to tune the antenna—usually the tips at each end of an element are made adjustable. Stainless steel hose clamps (beware—some “stainless steel” models do not have a stainless screw and will rust) are recommended for longest antenna life.

The remaining photos show possible fastening methods for joints that are not adjustable. At the upper right, machine screws and nuts hold the elements in place. At the lower left, sheet metal screws are used. At the lower right, rivets secure the tubing. If the antenna is to be assembled permanently, rivets are the best choice. Once in place, they are permanent. Properly installed, they rarely work free, regardless of vibration or wind. If aluminum rivets with aluminum mandrels are employed, they will never rust. Also, being aluminum, there is no danger of corrosion from interaction between dissimilar metals. If the antenna is to be disassembled and moved periodically, either machine or sheet

metal screws will work. If machine screws are used, however, take precautions to keep the nuts from vibrating free. Use of lock washers, lock nuts, and flexible adhesive such as silicone bathtub sealant or a thread-locking compound will keep the hardware in place. For portable or temporary use, such as Field Day, rivets may be held in place with electrical tape and removed when the operation is finished.

Use of a conductive grease at the element joints is essential for long life. Left untreated, the aluminum surfaces will oxidize in the weather, resulting in a poor connection. Some trade names for this conductive grease are Penetrox, OxGard, and Noalox. The copper-bearing anti-sieze compound SS-30 is another good choice. Many electrical supply houses and hardware stores carry these products.

DRIVEN ELEMENT

The ARRL recommends *plumbers de-light* construction, in which all elements are mounted directly on, and grounded to, the boom. This puts the entire array at dc ground potential, affording better lightning protection. A gamma- or T-match section can be used for matching the feed line to the array.

An alternative method is to insulate the driven element from the boom, but using a *hairpin* or *beta match*, the center point of which is electrically neutral and can be attached directly to the boom, restoring the dc ground for the driven element.

Direct feed designs in which the feed point impedance of the driven element is close to $50\ \Omega$ require no impedance matching structure. Like hairpin-matched designs, the driven element must be insulated from the boom, requiring some additional mechanical complexity.

Regardless of the design, a current or choke balun should be used (see the **Transmission Lines** chapter) to prevent the outer surface of the feed line shield from interacting with the antenna directly or picking up the radiated signal. Such interaction can degrade the

antenna's radiation pattern, especially by compromising signal rejection to the side and rear.

BOOM MATERIAL

The boom size for a rotatable Yagi or quad should be selected to provide stability to the entire system. The best diameter for the boom depends on several factors, but mostly the element weight, number of elements, and overall length. Two-inch-diameter booms should not be made any longer than 24 feet unless additional support is given to reduce both vertical and horizontal bending forces. Suitable reinforcement for a long 2 inch boom can consist of a truss or a truss and lateral support, as shown in **Figure 21.54**.

A boom length of 24 feet is about the point where a 3 inch diameter begins to be very worthwhile. This dimension provides a considerable amount of improvement in overall mechanical stability as well as increased clamping surface area for element hardware. The latter is extremely important to prevent rotation of elements around the boom if heavy icing is commonplace. Pinning an element to the boom with a large bolt helps in this regard. On smaller diameter booms, however, the elements sometimes work loose and tend to elongate the pinning holes in both the element and the boom. After some time the elements shift their positions slightly (sometimes from day to day) and give a ragged appearance to the system, even though this may not harm the electrical performance.

A 3 inch diameter boom with a wall thickness of 0.065 inch is very satisfactory for antennas up to about a five-element, 20 meter array that is spaced on a 40 foot boom. A truss is recommended for any boom longer than 24 feet. One possible source for large boom material is irrigation tubing sold at farm supply houses.

PUTTING IT TOGETHER

Once you assemble the boom and elements, the next step is to fasten the elements to the

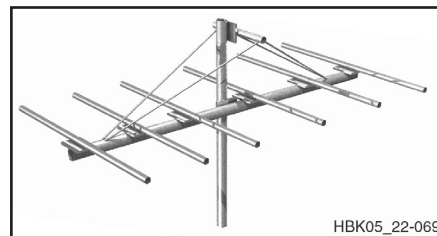

Figure 21.54 — A long boom needs both vertical and horizontal support. The cross-bar mounted above the boom can support a double truss, which will help keep the antenna in position.

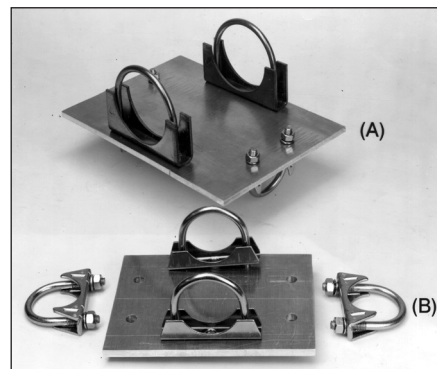

Figure 21.55 — The boom-to-element plate at A uses muffler-clamp-type U-bolts and saddles to secure the round tubing to the flat plate. The boom-to-mast plate at B is similar to the boom-to-element plate. The main difference is the size of materials used.

boom securely and then fasten the boom to the mast or supporting structure using mounting plates, as shown in **Figure 21.55**. Be sure to leave plenty of material on either side of the U-bolt holes on the element-to-boom mounting plates. The U-bolts selected should be a snug fit for the tubing. If possible, buy muffler-clamp U-bolts that come with saddles.

The *boom-to-mast* plate shown in **Figure 21.55B** is similar to the *boom-to-element* plate in 21.55A. The size of the plate and number of U-bolts used will depend on the size of the antenna. Generally, antennas for the bands up through 20 meters require only two U-bolts each for the mast and boom. Longer antennas for 15 and 20 meters (35 foot booms and up) and most 40 meter beams should have four U-bolts each for the boom and mast because of the torque that the long booms and elements exert as the antennas move in the wind. When tightening the U-bolts, be careful not to crush the tubing. Once the wall begins to collapse, the connection begins to weaken. Many aluminum suppliers sell $\frac{1}{4}$ inch or $\frac{3}{8}$ inch thick plates just right for this application. Often they will shear pieces to the correct size on request. As with tubing,

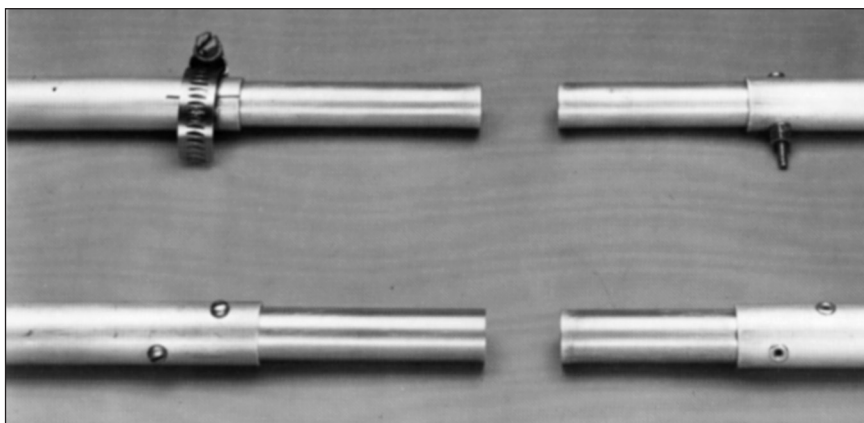

Figure 21.53 — Some methods of connecting telescoping tubing sections to build beam elements. See text for a discussion of each method.

the relatively hard 6061-T6 grade is a good choice for mounting plates.

The antenna should be put together with good-quality hardware. Stainless steel or galvanized hardware is best for long life and is available from several amateur radio dealers. Stainless steel hardware can develop surface defects called *galling* that can cause threads on nuts and bolts to seize. On hardware 1/4 inch and larger, the use of an anti-seize compound is recommended. Anti-seize compound is available from auto parts stores, or a small amount of grease or anti-oxidation compound can help lubricate the threads.

Rust will attack plated steel hardware after a short time, making nuts difficult, if not impossible, to remove. If you use plated hardware, paint it with a good zinc-chromate primer and a finish coat or two.

Good-quality hardware is more expensive initially, but if you do it right the first time, you won't have to take the antenna down after a few years and replace the hardware. Also, when repairing or modifying an installation, nothing is more frustrating than fighting rusty hardware at the top of a tower.

Project: Family of Computer-Optimized HF Yagis

Yagi designers are now able to take advantage of powerful personal computers and software to optimize their designs for the parameters of gain, F/R, and SWR across frequency bands. Dean Straw, N6BV, has designed a family of Yagis for HF bands. These can be found in **Tables 21.6 to 21.10**, for the 10, 12, 15, 17 and 20 meter amateur bands, respectively.

For 12 through 20 meters, each design has been optimized for better than 20 dB F/R and an SWR of less than 2:1 across the entire amateur frequency band. For the 10 meter band, the designs were optimized for the lower 800 kHz of the band, from 28.0 to 28.8 MHz. Each Yagi element is made of telescoping 6061-T6 aluminum tubing with 0.058 inch thick walls. This type of element can be telescoped easily, using techniques shown in Figure 21.53. Measuring each element to an accuracy of 1/8 inch results in performance remarkably consistent with the computations, without any need for tweaking or fine-tuning when the Yagi is on the tower.

The dimensions shown are designed for specific telescoping aluminum elements, but the elements may be scaled to different sizes by using the information about tapering and scaling in *The ARRL Antenna Book*, although with a likelihood of deterioration in performance over the whole frequency band.

Each element is mounted above the boom with a heavy rectangular aluminum boom-to-element plate, by means of galvanized U-bolts with saddles, as shown in Figure 21.55. This

Table 21.6

10 Meter Optimized Yagi Designs

	Spacing Between Elements (in)	Seg 1 Length (in)	Seg 2 Length (in)	Seg 3 Length (in)	Midband Gain F/R
310-08					
Refl	0	24	18	66.750	7.2 dBi
DE	36	24	18	57.625	22.9 dB
Dir 1	54	24	18	53.125	
410-14					
Refl	0	24	18	64.875	8.4 dBi
DE	36	24	18	58.625	30.9 dB
Dir 1	36	24	18	57.000	
Dir 2	90	24	18	47.750	
510-24					
Refl	0	24	18	65.625	10.3 dBi
DE	36	24	18	58.000	25.9 dB
Dir 1	36	24	18	57.125	
Dir 2	99	24	18	55.000	
Dir 3	111	24	18	50.750	

Note: For all antennas, the tube diameters are Seg 1=0.750 inch, Seg 2=0.625 inch, Seg 3=0.500 inch.

Table 21.7

12 Meter Optimized Yagi Designs

	Spacing Between Elements (in)	Seg 1 Length (in)	Seg 2 Length (in)	Seg 3 Length (in)	Midband Gain F/R
312-10					
Refl	0	36	18	69.000	7.5 dBi
DE	40	36	18	59.125	24.8 dB
Dir 1	74	36	18	54.000	
412-15					
Refl	0	36	18	66.875	8.5 dBi
DE	46	36	18	60.625	27.8 dB
Dir 1	46	36	18	58.625	
Dir 2	82	36	18	50.875	
512-20					
Refl	0	36	18	69.750	9.5 dBi
DE	46	36	18	61.750	24.9 dB
Dir 1	46	36	18	60.500	
Dir 2	48	36	18	55.500	
Dir 3	94	36	18	54.625	

Note: For all antennas, the tube diameters are: Seg 1 = 0.750 inch, Seg 2 = 0.625 inch, Seg 3 = 0.500 inch.

method of element mounting is rugged and stable, and because the element is mounted away from the boom, the amount of element detuning due to the presence of the boom is minimal. The element dimensions given in each table already take into account any element detuning due to the mounting plate. The element mounting plate for all the 10 meter Yagis is a 0.250 inch thick flat aluminum plate, 4 inches wide by 4 inches long. For the 12 and 15 meter Yagis, a 0.375 inch thick flat aluminum plate 5 inches wide by 6 inches long is used, and for the 17 and 20 meter Yagis a

0.375 inch thick flat aluminum plate, 6 inches wide by 8 inches long is used. Where the plate is rectangular, the long dimension is in line with the element.

Each design table shows the dimensions for *one-half* of each element, mounted on one side of the boom. The other half of each element is the same, mounted on the other side of the boom. Use a tubing sleeve inside the center portion of the element so that the element is not crushed by the mounting U-bolts. Each telescoping section is inserted 3 inches into the next size of tubing. For example, in the 310-08

Table 21.8

15 Meter Optimized Yagi Designs

	Spacing Between Elements (in)	Seg 1 Length (in)	Seg 2 Length (in)	Seg 3 Length (in)	Seg 4 Length (in)	Midband Gain F/R
315-12						
Refl	0	30	36	18	61.375	7.6 dBi
DE	48	30	36	18	49.625	25.5 dB
Dir 1	92	30	36	18	43.500	
415-18						
Refl	0	30	36	18	59.750	8.3 dBi
DE	56	30	36	18	50.875	31.2 dB
Dir 1	56	30	36	18	48.000	
Dir 2	98	30	36	18	36.625	
515-24						
Refl	0	30	36	18	62.000	9.4 dBi
DE	48	30	36	18	52.375	25.8 dB
Dir 1	48	30	36	18	47.875	
Dir 2	52	30	36	18	47.000	
Dir 3	134	30	36	18	41.000	

Note: For all antennas, the tube diameters (in inches) are: Seg 1 = 0.875, Seg 2 = 0.750, Seg 3 = 0.625, Seg 4 = 0.500.

Table 21.9

17 Meter Optimized Yagi Designs

	Spacing Between Elements (in)	Seg 1 Length (in)	Seg 2 Length (in)	Seg 3 Length (in)	Seg 4 Length (in)	Seg 5 Length (in)	Midband Gain F/R
317-14							
Refl	0	24	24	36	24	60.125	8.1 dBi
DE	65	24	24	36	24	52.625	24.3 dB
Dir 1	97	24	24	36	24	48.500	
417-20							
Refl	0	24	24	36	24	61.500	8.5 dBi
DE	48	24	24	36	24	54.250	27.7 dB
Dir 1	48	24	24	36	24	52.625	
Dir 2	138	24	24	36	24	40.500	

Note: For all antennas, tube diameters (inches) are: Seg 1=1.000, Seg 2=0.875, Seg 3=0.750, Seg 4=0.625, Seg 5=0.500.

Table 21.10

20 Meter Optimized Yagi Designs

	Spacing Between Elements (in)	Seg 1 Length (in)	Seg 2 Length (in)	Seg 3 Length (in)	Seg 4 Length (in)	Seg 5 Length (in)	Seg 6 Length (in)	Midband Gain F/R
320-16								
Refl	0	48	24	20	42	20	69.625	7.3 dBi
DE	80	48	24	20	42	20	51.250	23.4 dB
Dir 1	106	48	24	20	42	20	42.625	
420-26								
Refl	0	48	24	20	42	20	65.625	8.6 dBi
DE	72	48	24	20	42	20	53.375	23.4 dB
Dir 1	60	48	24	20	42	20	51.750	
Dir 2	174	48	24	20	42	20	38.625	

Note: For all antennas, tube diameters (inches) are: Seg 1=1.000, Seg 2=0.875, Seg 3=0.750, Seg 4=0.625, Seg 5=0.500, Seg 6=0.375.

design for 10 meters (3 elements on an 8 foot boom), the reflector tip, made out of 1/2 inch OD tubing, sticks out 66.75 inches from the 5/8 inch OD tubing. For each 10 meter element, the overall length of each 5/8 inch OD piece of tubing is 21 inches, before insertion into the 3/4 inch piece. Since the 3/4 inch OD tubing is 24 inches long on each side of the boom, the center portion of each element is actually 48 inches of uncut 3/4 inch OD tubing.

The boom for all these antennas should be constructed with at least 2 inch OD tubing, with 0.065 inch wall thickness. Because each boom has three inches of extra length at each end, the reflector is actually placed three inches from one end of the boom. For the 310-08 design, the driven element is placed 36 inches ahead of the reflector, and the director is placed 54 inches ahead of the driven element. The antenna is attached to the mast with the boom-to-mast mounting plate shown in Figure 21.55.

Each antenna is designed with a driven element length appropriate for a gamma or T matching network, as shown in Figure 21.56. The variable gamma or T capacitors can be

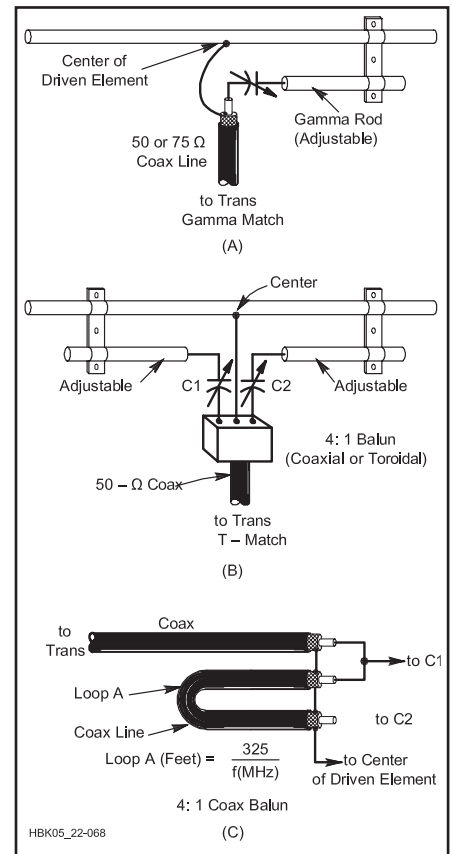

Figure 21.56 — Illustrations of gamma and T matching systems. At A, the gamma rod is adjusted along with the capacitor until the lowest SWR is obtained. A T match is shown at B. It is the same as two gamma-match rods. A 4:1 coaxial balun transformer for use with the T match is shown at C.

housed in small plastic enclosures for weatherproofing; receiving-type variable capacitors with close plate spacing can be used at powers up to a few hundred watts. Maximum capacitance required is usually 140 pF at 14 MHz and proportionally less at the higher frequencies.

The driven-element's length may require slight readjustment for best match, particularly if a different matching network is used. *Do not change either the lengths or the telescoping tubing schedule of the parasitic elements* — they have been optimized for best performance and will not be affected by tuning of the driven element.

TUNING ADJUSTMENTS

To tune the gamma match, adjust the gamma capacitor for best SWR, then adjust the position of the shorting strap or bar that connects

the gamma rod to the driven element. Repeat this alternating sequence of adjustments until a satisfactory SWR is reached.

To tune the T-match, the position of the shorting straps and C1 and C2 are adjusted alternately for a best SWR. To maintain balance of the antenna, the position of the straps and capacitor settings should be the same for each side and adjusted together. A coaxial 4:1 balun transformer is shown at Figure 21.56C. A toroidal balun can be used in place of the coax model shown. The toroidal version has a broader frequency range than the coaxial one. The T match is adjusted for 200 Ω, and the balun steps this balanced value down to 50 Ω, unbalanced. Or the T match can be set for 300 Ω, and the balun used to step this down to 75 Ω unbalanced.

Dimensions for the gamma and T match rods will depend on the tubing size used and the

spacing of the parasitic elements of the beam. Capacitors C1 and C2 can be 140 pF for 14 MHz beams. Somewhat less capacitance will be needed at 21 and 28 MHz.

Preliminary matching adjustments can be done on the ground. The beam should be aligned vertically so that the reflector element is closest to and a few feet off the ground, with the beam pointing upward. The matching system is then adjusted for best SWR. When the antenna is raised to its operating height, only slight touch-up of the matching network may be required.

A *choke balun* (see the **Transmission Lines** chapter) should be used to isolate the coaxial feed line shield from the antenna. Secure the feed line to the boom of the antenna between the feed point and the supporting mast.

21.7 Quad and Loop Antennas

One of the more effective DX antennas is the *quad*. It consists of two or more loops of wire, each supported by a bamboo or fiberglass cross-arm assembly. The loops are $\frac{1}{4} \lambda$ per side (one full wavelength overall). One loop is driven and the other serves as a parasitic element — usually a reflector. The design of the quad is similar to that of the Yagi, except that the elements are loops instead of dipoles. A two-element quad can achieve better F/R, gain, and SWR across a band, at the expense of greater mechanical complexity compared to a two-element Yagi and very nearly the same performance as a three-element Yagi. Small loops with a circumference of less than 0.3λ are discussed in the next section.

A variation of the quad is called the *delta loop*. The electrical properties of both antennas are the same. Both antennas are shown in **Figure 21.57**. They differ mainly in their physical properties, one being of plumber's delight construction, while the other uses insulating support members. One or more directors can be added to either antenna if additional gain and directivity are desired, though most operators use the two-element arrangement.

It is possible to interlace quads or deltas for two or more bands, but if this is done the lengths calculated using the formulas given in Figure 21.57 may have to be changed slightly to compensate for the proximity effect of the second antenna. Using a tuning capacitor as shown in the following project allows the antenna to be adjusted for peak performance without cumbersome adjustment of wire lengths.

If multiple arrays are used, each antenna should be tuned separately for maximum for-

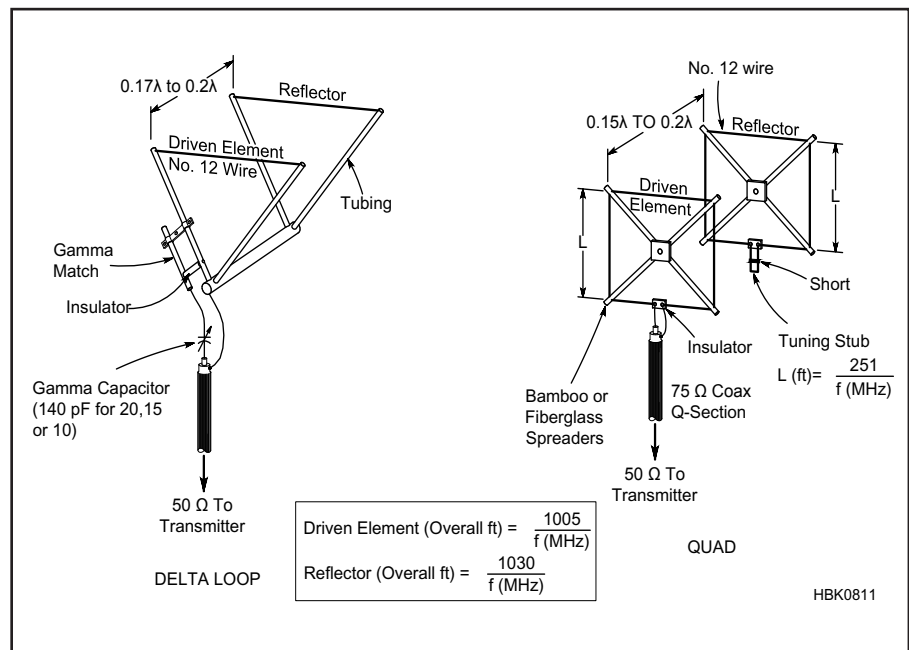

Figure 21.57 — Information on building a quad or a delta-loop antenna. The antennas are electrically similar, but the delta-loop uses plumber's delight construction. The $\frac{1}{4} \lambda$ length of 75 Ω coax or Q-section acts as a synchronous transmission-line transformer from the approximate 100 Ω feed point impedance of the quad to the 50 Ω feed line.

ward gain, or best front-to-rear ratio, as observed on a field-strength meter. The reflector stub on the quad should be adjusted for this condition. The resonance of the antenna can be found by checking the frequency at which the lowest SWR occurs. By lengthening or shortening it, the driven element length can be adjusted for resonance in the most-used portion of the band.

A gamma match can be used at the feed point of the driven element to match the impedance to that of coaxial cable. Because the loop's feed point impedance is *higher* than that of 50 Ω coaxial cable, a *synchronous transmission line transformer* or *Q-section* (see the **Transmission Lines** chapter) with an impedance intermediate to that of the loop and the coaxial cable can be used.

Project: Five-Band, Two-Element HF Quad

Two multi-band quad designs covering 20 through 10 meters are described in this project. One was constructed by William A. Stein, KC6T, from scratch, and the other was built by Al Doig, W6NBH, using modified commercial triband quad hardware. The principles of construction and adjustment are the same for both models, and the performance results are also essentially identical. One of the main advantages of this design is the ease of (relatively) independent performance adjustments for each of the five bands. These quads were described by William A. Stein, KC6T, in *QST* for April 1992. Both models use 8-foot-long, 2 inch diameter booms and conventional X-shaped spreaders (with two sides of each quad loop parallel to the ground).

Each driven element is fed separately, but running five separate feed lines to the station would be unwieldy. A remote coax switch on the boom is used to select the feed line for each element. A gamma match or quarter-wave synchronous transmission line transformer is used to match the feed point impedance of the element to 50 Ω .

These designs can also be simplified to monoband quads by using the formulas in Figure 21.57 for loop dimensions and spacing. It is recommended to the antenna builder unfamiliar with quads that a monoband quad be attempted first in order to become acquainted with the techniques of building a quad. Once comfortable with constructing and erecting the quad, success with a multiband design is much easier to achieve.

Complete construction details and more information about the performance of these designs are available with the online content.

21.7.1 Large Loop Antennas

The loop antennas described in this section are continuous loops at least one wavelength in circumference and formed into open shapes with sides that are approximately equal, such as triangles, diamonds, squares, or circles. Smaller loops used for receiving purposes are discussed in the *ARRL Antenna Book*. Loops with ratios of side lengths greater than 2 or 3:1 begin to have special characteristics beyond the scope of this chapter.

A 1λ loop can be thought of as two $\frac{1}{2} \lambda$ dipoles with their ends connected together and pulled apart into an open shape, as described above. The feed point of one dipole is replaced with a short circuit so that there is only one feed point on the antenna. As such, the current and voltage distribution around the loop is an extension of Figure 21.1. Three typical loop shapes and the current distributions on them are shown in **Figure 21.58**. Note that the current flow reverses at points $\frac{1}{4} \lambda$ to either

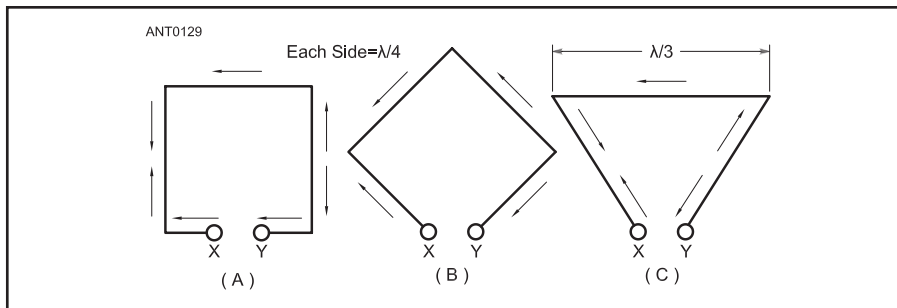

Figure 21.58 — At A and B, loops have sides $\frac{1}{4} \lambda$ long, and at C having sides $\frac{1}{3} \lambda$ long for a total conductor length of 1λ . The polarization depends on the orientation of the loop and on the position of the feed point (terminals X-Y) around the perimeter of the loop.

side of the feed point. That means the current direction opposite the feed point is the same as at the feed point.

The maximum radiation strength of a 1λ loop is perpendicular to the plane of the loop and minimum in the plane of the loop. If the loop is horizontal, the antenna radiates best straight up and straight down and poorly to the sides. The gain of a 1λ loop in the direction of maximum radiation is approximately 1 dBd.

If the plane of the three loops shown in Figure 21.58 is vertical, the radiation is horizontally polarized because the fields radiated by the vertical components of current are symmetrical and opposing, so they cancel, leaving only the horizontally polarized fields that reinforce each other perpendicular to the loop plane. If the feed point of the antenna is moved to a vertical side or the antenna is rotated 90° , it is the horizontally polarized fields that will cancel, leaving a vertically polarized field, still maximum perpendicular to the plane of the loop. Feeding the loop at some other location, rotating the loop by some intermediate value, or constructing the loop in an asymmetrical shape will result in polarization somewhere between vertical and horizontal, but the maximum radiation will still occur perpendicular to the plane of the loop.

In contrast to straight-wire antennas, the electrical length of the circumference of a 1λ loop is shorter than the actual length. For a loop made of bare #18 AWG wire and operating at a frequency of 14 MHz, so that the length-to-diameter ratio is very large, the loop will be close to resonance in free space when:

$$\text{Length (feet)} = 1032/f \text{ (MHz)} \quad (7)$$

The radiation resistance of a resonant 1λ loop is approximately 120 Ω under these conditions. Since the loop dimensions are larger than those of a $\frac{1}{2} \lambda$ dipole, the radiation efficiency is high and the SWR bandwidth of the antenna significantly larger than for the dipole.

The loop antenna is resonant on all frequencies at which it is an integral number of wavelengths in circumference; $f_0, 2f_0, 3f_0,$

etc. That means an 80 meter 1λ loop will also have a relatively low feed point impedance on 40, 30, 20, 15, 12, and 10 meters. As each side of the loop becomes longer electrically, the radiation pattern of the loop begins to develop nulls perpendicular to the plane of the loop and lobes that are closer to the plane of the loop. A horizontal diamond-shaped loop with legs more than a wavelength long is a *rhombic* antenna, which can develop significant gain along the long axis of the antenna. (The diamond-shaped rhombic is the origin of the symbol of the ARRL and many other radio organizations.)

21.7.2 Small Transmitting Loop Antennas

The small gap-resonated, circular loop antenna for HF transmitting was originally patented by John H. Dunlavy, Jr. His efficient small loop design can be tuned over wide bandwidths. The July/August 2018 issue of *QEX* features several articles on these antennas. **Figure 21.59** shows a typical “mag” loop being used for portable operation. Their small size and profile make it easy to mount them on a tripod (as seen in the figure) or other small mast. Models are available for both permanent and temporary installation.

Small loops are most popular on 7 MHz and higher frequencies, although larger models can be used on 3.5 and even 1.8 MHz. (See the article “A High-Power 160- and 80-Meter Transmitting Loop Antenna, by Steve Adler, VK5SFA.)

These loops consist of a one-turn primary (main) loop antenna having a circumference of less than $\frac{3}{8} \lambda$ that is interrupted along its length (usually opposite the feed point) by a gap, with a tuning capacitor connected across the gap so the antenna can be tuned over a wide tuning range. A single-turn secondary (feed) loop, much smaller than the primary loop, is inductively coupled to the primary loop. Both loops are in the same plane. The secondary loop diameter is optimized based on the diameter of the primary loop so that variation in



Figure 21.59 — A typical small loop being used for portable operation with a QRP transceiver. Be sure to account for minimum safe distances to avoid excessive RF exposure levels.

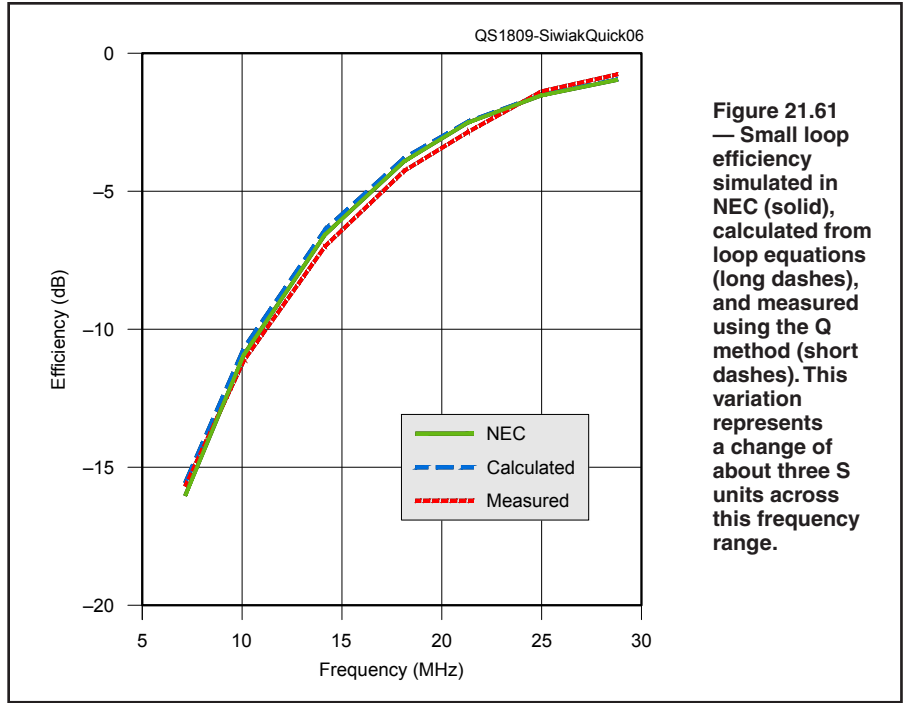

Figure 21.61 — Small loop efficiency simulated in NEC (solid), calculated from loop equations (long dashes), and measured using the Q method (short dashes). This variation represents a change of about three S units across this frequency range.

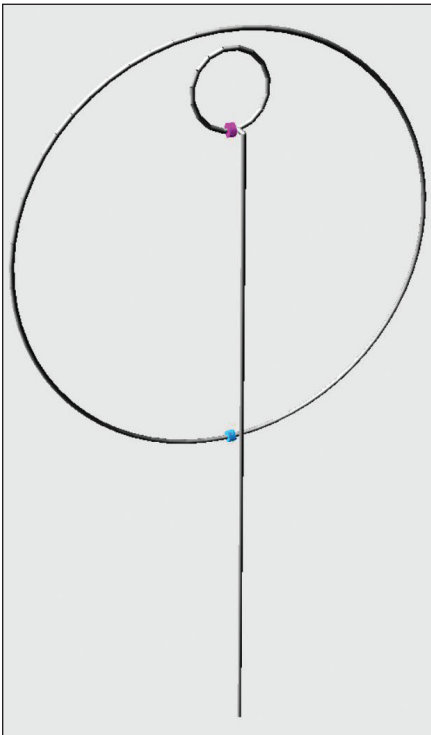

Figure 21.60 — The electrically small HF loop includes a main loop and a secondary feeding loop, both in the same plane, and a coaxial cable feed line also in the same plane, but slightly offset so that the cable does not touch the bottom of the main loop. A resonating capacitor connects across a gap at the bottom of the main loop.

feed impedance is minimized over the band of operation. A low impedance transmission line ($50\ \Omega$) connects to the terminals of the secondary loop. **Figure 21.60** shows a model of the loop. Because of the antenna's high Q, the operating bandwidth is very narrow, requiring retuning every few kHz.

The pattern of these small loops is a bidirectional "figure 8" similar to small direction-finding loops with the null broadside to the plane of the loop. The depth of the null varies from 5 – 20 dB across the HF spectrum as described in the Sep 2018 *QST* article "Small Gap-Resonated HF Loop Antennas" by Kai Siwiak, KE4PT, and Richard Quick, W4RQ. (included with this book's online material). The *ARRL Antenna Book* chapter on Loop Antennas presents more information and construction guidelines.

Because the radiation resistance of these small loops is so small (less than $1\ \Omega$), low-loss construction techniques are very important, particularly in the adjustable tuning capacitor. Siwiak and Quick's article presents efficiencies as shown in **Figure 21.61** which seem quite low on the lower-frequency bands, if, however, an S unit represents a 6 dB change, the overall variation across the HF spectrum is only about 3 S units.

When using these small loops in the field, pay particular attention to RF exposure and minimum safe distances at different power levels. A table of distances is provided in the Portable Stations section of the chapter **Assembling a Station**. Because these antennas have such a high Q, the near field strengths can be very high, even at low power levels.

Project: Low-Band Quad and Delta Loops

(The following material is summarized from Chapter 10 of *ON4UN's Low-Band DXing, Fifth Edition*.) Dimensions for these designs assume an operating frequency of 3.75 MHz. The dimensions for the loops in this section may be scaled to frequencies in the 160, 60, 40 or 30 meter bands. The performance of the loops will vary with height above ground and ground conductivity.

SQUARE LOOP

Figure 21.62 shows the vertical-plane radiation patterns for a quad loop over very poor ground and over very good ground on the same dB scale for both horizontal and vertical polarization. Polarization of the loop depends on the location of the feed point, as shown in the figure.

The vertically polarized quad loop can be considered as two shortened, top-loaded vertical dipoles spaced $\frac{1}{4}\ \lambda$ apart. Broadside radiation from the horizontal elements of the quad is very low because the currents in the horizontal legs are approximately equal but in opposite directions in each half of the leg. The radiation angle in the broadside direction will be essentially the same as for either of the vertical members.

The resulting radiation angle will depend on the quality of the ground up to several wavelengths away from the antenna, as is the case with all vertically polarized antennas. The quality of the ground is as important as it is for any other vertical antenna, meaning

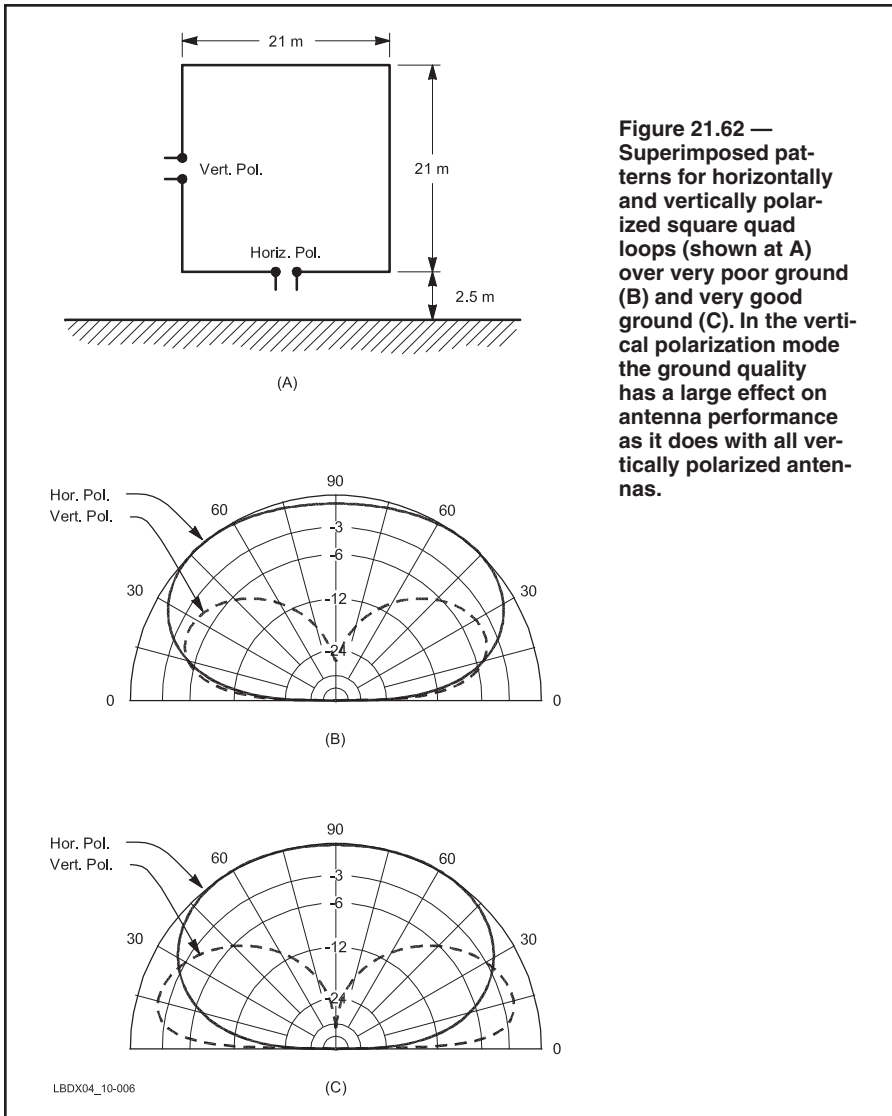

Figure 21.62 — Superimposed patterns for horizontally and vertically polarized square quad loops (shown at A) over very poor ground (B) and very good ground (C). In the vertical polarization mode the ground quality has a large effect on antenna performance as it does with all vertically polarized antennas.

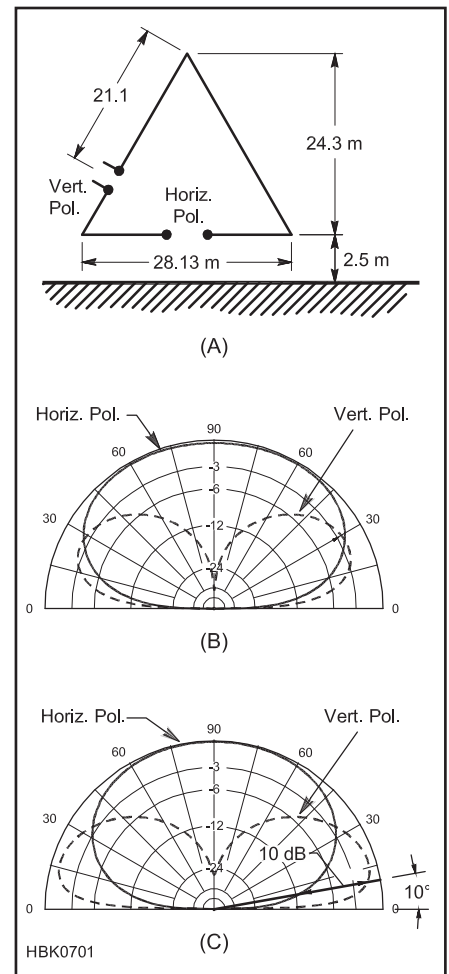

Figure 21.63 — Superimposed patterns for horizontally and vertically polarized delta quad loops (shown at A) over very poor ground (B) and very good ground (C). Over better ground, the vertically polarized loop performs much better at low radiation angles, while over both good and poor ground the vertically polarized loop gives good discrimination against high-angle local signals.

that vertically polarized loops close to the ground will not work well over poor soil. In a typical situation on 80 meters, a vertically polarized quad loop will radiate an excellent low-angle signal (lobe peak at approximately 21°) when operated over average ground. Over poorer ground, the peak elevation angle would be closer to 30° . The horizontal directivity is rather poor and amounts to approximately 3.3 dB of side rejection at any elevation angle.

A horizontally polarized quad-loop antenna can be thought of as two stacked short dipoles with a peak elevation angle dependent on the height of the loop. The low horizontally polarized quad (top at 0.3λ) radiates most of its energy right at or near zenith angle (straight up). At low wave angles (20° to 45°) the horizontally polarized loop shows more front-to-side ratio (5 to 10 dB) than the vertically polarized rectangular loop.

With a horizontally polarized quad loop

the angle of peak radiation is very dependent on the antenna height but not so much on the quality of the ground. At very low heights, the angle of peak radiation varies between 50° and 60° (but is rather constant all the way up to 90°). This is very good for NVIS and regional communication but not very good for DX. As far as gain is concerned, there is a 2.5-dB gain difference between very good and very poor ground, which is only half the difference found with the vertically polarized loop.

Comparing the gains of the horizontally and vertically polarized loops, Figure 21.62 shows that at very low antenna heights the gain is about 3 dB better for the horizontally polarized loop. But this gain exists at a high wave angle (50° to 90°), while the vertically polarized loop at very low heights radiates at 17° to 25° .

At heights from 3 to 6 meters for the bottom leg, feed point resistance for the horizontally polarized loop is approximately 100 to

120 Ω over average ground. For vertical polarization, feed point resistance varies from 200 to 170 Ω .

The quad loop feed point should be symmetrical, whether you feed the quad in the middle of the vertical or the horizontal wire. At the feed point, use a common-mode choke balun (see the **Transmission Lines** chapter) as current flowing on the outside of the coaxial feed line could upset the radiation pattern.

DELTA LOOP

Figure 21.63 shows the configuration as well as the superimposed elevation patterns for vertically and horizontally polarized low-height equilateral triangle delta loops over two different types of ground (same dB scale). The model was constructed for a frequency of 3.75 MHz. The base is 2.5 meters above

ground, which puts the apex at 26.8 meters. Over good ground, the vertically polarized delta loop shows nearly 3 dB front-to-side ratio at the peak radiation angle of 22°. With average ground the gain is 1.3 dBi.

Over very poor ground, the horizontally polarized delta loop is better than the vertically polarized loop for all wave angles above 35°. Below 35° the vertically polarized loop takes over, but quite marginally. The maximum gain of the vertically and the horizontally polarized loops differs by only 2 dB, but the big difference is that for the horizontally polarized loop, the gain occurs at almost 90°, while for the vertically polarized loop it occurs at 25°. The vertically polarized antenna also gives good high-angle rejection (rejection of local signals), while the horizontally polarized loop will not.

Over very good ground, the performance at low angles is greatly improved for both polarizations. The vertically polarized loop is still better at any elevation angle under 30° than when horizontally polarized. At a 10° radiation angle the difference is as high as 10 dB. This makes the vertically polarized delta over good ground far superior for DX operating.

Most practical delta loops show a feed point impedance between 50 and 100 Ω, depending on the exact geometry and coupling to other antennas. The antenna can be fed directly with a 50 or 70 Ω coaxial cable, or via a 70 Ω quarter-wave transformer (see the **Transmission Lines** chapter) if the feed point impedance is near 100 Ω. At the feed point, use a common-mode choke balun (see the **Transmission Lines** chapter) as current flowing on the outside of the coaxial feed line could upset the radiation pattern.

THE BOTTOM-CORNER-FED DELTA LOOP

Figure 21.64 shows the layout of the delta loop being fed at one of the two bottom corners. The antenna is slightly compressed from the previous section with a slightly lower apex and longer base than the loop described in the previous section. Because of the “incorrect” location of the feed point, cancellation of radiation from the base wire is incomplete, resulting in a significant horizontally polarized radiation component. The total field has a very uniform gain coverage (within 1 dB) from 25° to 90°. This may be a disadvantage for the rejection of high-angle signals when working DX at low angles.

Due to the feed point location, the end-fire radiation (radiation in line with the loop) has become asymmetrical with a side null of nearly 12 dB at the peak radiation angle of 29°. The loop actually radiates its maximum signal about 18° off the broadside direction. This feed point configuration greatly affects the pattern of the loop, so use bottom-corner-feed with care.

Project: Two-Band Loop for 30 and 40 Meters

The following antenna design is from a *QST* Hints and Kinks entry by James Brenner, NT4B, in the May 1989 issue. The version

shown in **Figure 21.65** is fed at the apex of a delta loop but can be adapted to a square or quad loop shape.

The original design was derived from “The Mini X-Q Loop” in *All About Cubical Quad Antennas* by Bill Orr, W6SAI (now out of print)

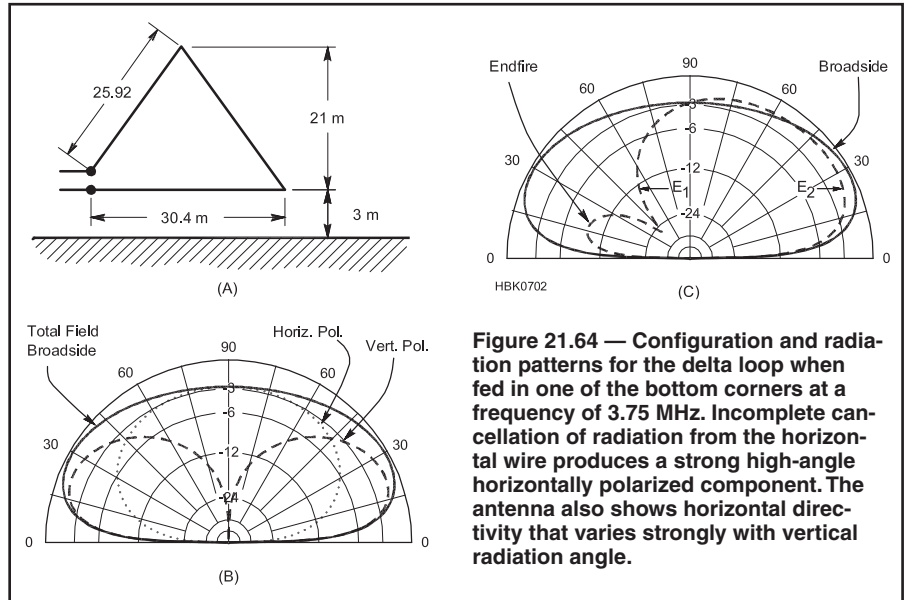

Figure 21.64 — Configuration and radiation patterns for the delta loop when fed in one of the bottom corners at a frequency of 3.75 MHz. Incomplete cancellation of radiation from the horizontal wire produces a strong high-angle horizontally polarized component. The antenna also shows horizontal directivity that varies strongly with vertical radiation angle.

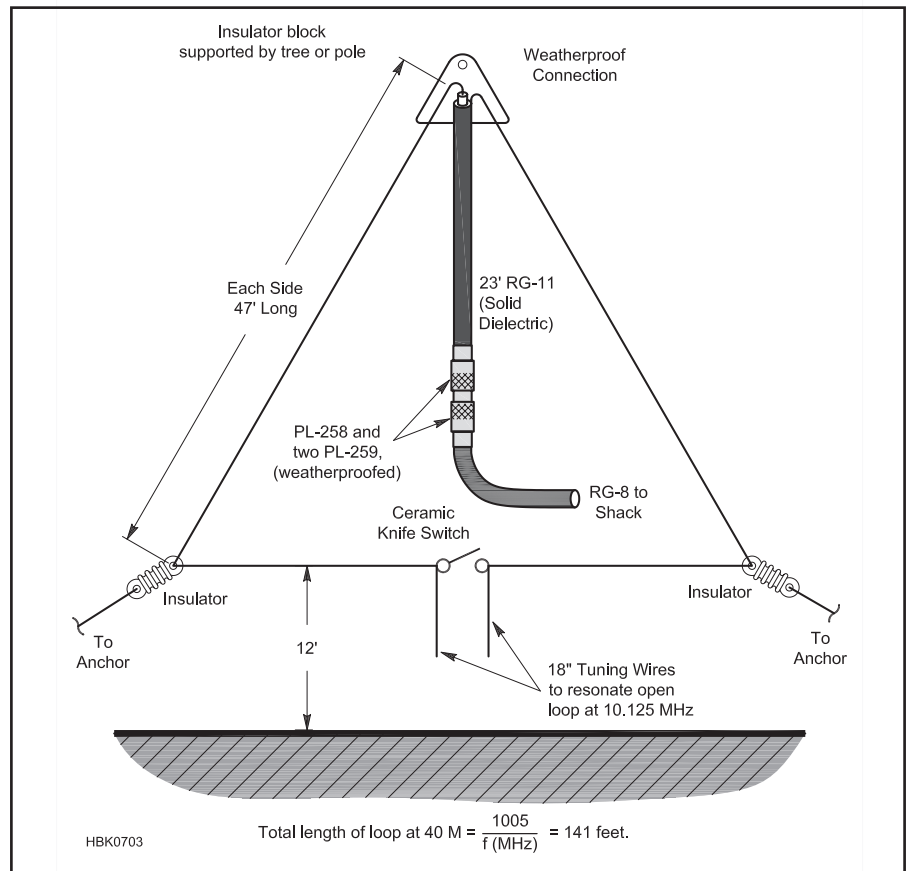

Figure 21.65— NT4B’s 30 and 40 meter loop is fed at the top via a quarter-wave 40 meter matching transformer made of 75 Ω coax. Note the 18 inch tuning wires used to lower the antenna’s 30 meter resonance from 10.5 to 10.1 MHz. Adjust the length of these wires to set the 30 meter resonant frequency.

which is $1\frac{1}{2}\lambda$ in circumference, with an open circuit opposite the feed point. That antenna has approximately 1 dB of additional gain over a 1λ loop. Since 30 and 40 meters are close to the same $1:1\frac{1}{2}\lambda$ ratio, one loop can be converted between 1λ on 40 meters and $1\frac{1}{2}\lambda$ on 30 meters with a switch.

A large, ceramic SPST knife switch is installed in the center of the delta loop's bottom leg as shown in Figure 21.65. With the switch open, the loop acts as $1\frac{1}{2}\lambda$ loop at 10.5 MHz, so 18 inch wires were added to the loop on either side of the switch to lengthen the antenna and lower the resonant frequency to 10.1 MHz. Closing the switch shorts out the wires, and the loop becomes a regular 1λ continuous loop for 40 meters.

Note that there is fairly high voltage present at the switch when transmitting on 30 meters. If a relay is used, be sure the contact spacing is sufficient to avoid arcing or use additional pairs of contacts to increase the overall spacing.

The antenna is fed through a quarter-wave transformer (see the **Transmission Lines** chapter) of $75\ \Omega$ RG-11 coax, approximately 23 feet long. According to the author, when configured for 40 meters, the loop has a satisfactory SWR of less than 2:1 on 15 meters. In addition, the 30 meter configuration can be used successfully on 80 meters with the use of an antenna tuner.

Project: Multiband Horizontal Loop Antenna

Along with the multiband, non-resonant dipole, many amateurs operate on HF with great success using a horizontal loop antenna. All that is required are at least three supports able to hold the corners of the antenna 20 or more feet above the ground (and even that is negotiable) and enough room for a loop of wire one wavelength or more in circumference at the lowest frequency of operation. (Smaller loops can be used with an impedance-matching unit.)

Start by calculating the total length of wire using Equation 7. You'll need one insulator for each support and lengths

of rope that are at least twice the height to which the insulator will be raised. You can feed the antenna at one of the corner insulators or anywhere along the wire with a separate insulator. Examples of corner insulators are shown in **Figure 21.66**. Using floating insulators allows the wire to move as the antenna flexes. One of the insulators should be of the fixed type, or the antenna can be fed at one corner with the loop wires attached to a pair of insulators sharing a common support rope. This holds the antenna feed point in place.

If the loop is only going to be used on the band for which it is resonant, coaxial cable can be used as the feed line, since SWR will be low. A choke balun at the feed point is recommended. For multiband use, open-wire feed line should be used, with an impedance-matching unit in the station. See Figure 21.15

for an example of how open-wire line can be attached at the feed point.

The impedance at the station end of the open-wire line can be matched to $50\ \Omega$ for coaxial cable with a balanced ATU or a balun and regular ATU. The impedance will vary widely, so do not expect a fixed-ratio balun (1:1, 4:1, 9:1, and so on) to provide a match over wide frequency range. The balun's function is to connect the open-wire line to unbalanced equipment or feed lines.

On its fundamental frequency, the antenna's maximum radiation will be straight up, making it most useful for regional communications at high elevation angles with the occasional DX contact. At higher frequencies, the loop will radiate more strongly at lower angles for better signal strengths at long distances. An example design is shown in **Figure 21.67**.

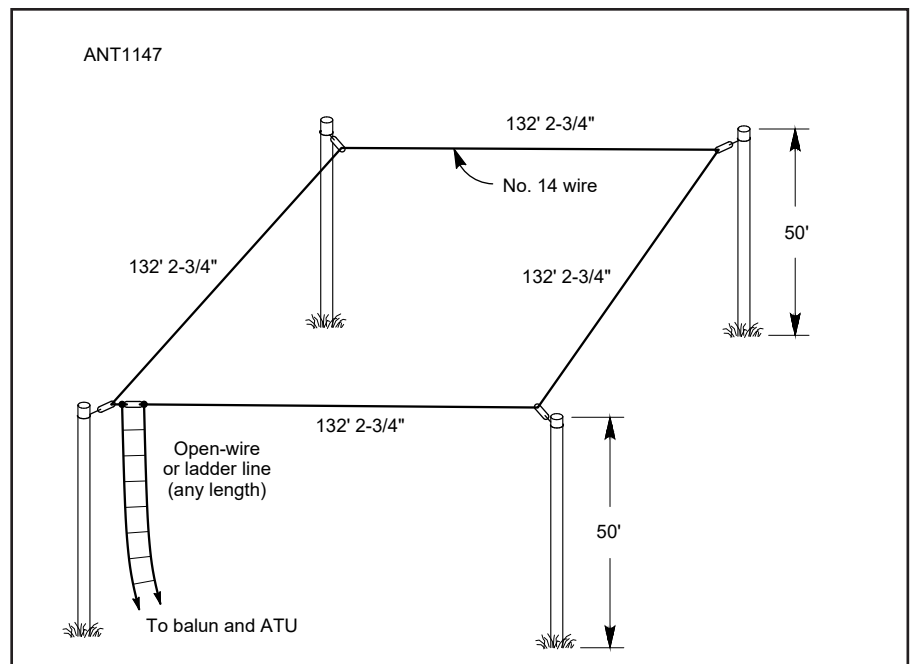

Figure 21.67 — An example of a horizontal full-wave loop designed for 1.9 MHz. The antenna can be fed with any length of open-wire or ladder line. The loop is usable on all HF bands.

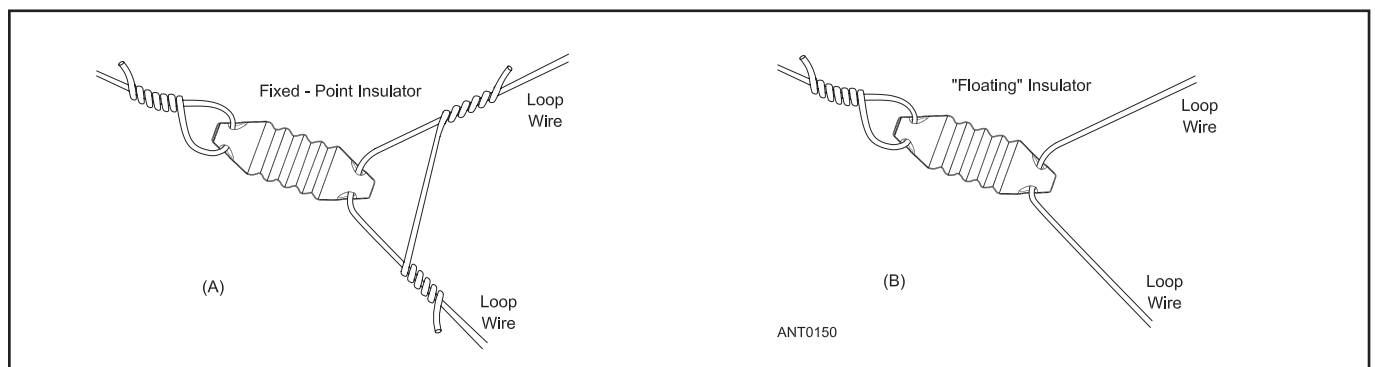

Figure 21.66 — Two methods of installing the insulators at the loop corners.

21.8 HF Mobile Antennas

HF mobile operation has been part of amateur radio since the 1930s. Mobile operation has become very popular with advances in antenna design and excellent mobile radios. Material in this section was contributed and updated by Alan Applegate, KØBG, whose website (www.k0bg.com) has many useful pages on HF mobile stations and operating.

Portable stations frequently use the same type of antennas as for mobile operation. Helically wound whips and base-loaded whips are the most common. The same guidelines for design and use apply to portable operation: minimize losses in the antenna's construction, configure any loading for the most current in radiating structures, and minimize ground losses with screens or radial wires.

High frequency (HF) mobile antennas come in every size and shape imaginable, from simple whips to elaborate, computer-controlled behemoths. Regardless of the type and construction, an HF mobile antenna should have a few important attributes.

- **Sturdiness:** It should be permanently mounted (without altering the vehicle's safety equipment) to stay upright at highway speeds with a minimum of sway.
- **Mechanically stable:** Sudden stops or sharp turns won't cause it to sway about, endangering others.
- **Flexibly mounted:** Permits bending around branches and obstacles at low speeds.
- **Weatherproof:** Withstands the effects of wind, rain, snow, and ice.
- **Tunable:** If multiband operation is desired, be tunable to different HF bands without stopping the vehicle.
- Be easily removable when required.
- Be as efficient as possible.

Of all the antenna choices available, the *whip* antenna — a self-supporting rod or wire mounted at its base — has passed the test of time as providing all of these attributes in one way or another. The following sections discuss the different types of whips, how they are attached to and interact with the vehicle, and how they are connected to the transmitter.

21.8.1 Simple Whips

The simplest of antennas is a quarter-wave whip, but it's only practical on the upper HF bands because of the required length. For example, a 10 meter quarter-wavelength antenna is about 8 feet long. It doesn't require a loading coil, so its efficiency is approximately 80%. The reason efficiency isn't 100% is because of resistive losses in the whip itself, stray capacitance losses in the mounting hardware, and ground losses, which we'll cover later. The end result is that the feed point impedance at the antenna's base is very close to 50 Ω.

As we move lower in frequency, the physical

length must increase for an equivalent electrical length, but there is a limit. In most localities, the maximum height at the tip of the antenna needs to be less than 13.5 feet (4.1 meters). This generally limits whip length to 10.5 feet (3.2 meters) for an average installation on a vehicle. Creating a resonant antenna below this length on 10 or 12 meters isn't a problem. On the 15 meter and lower frequency bands, 10.5 feet is not long enough for a resonant whip antenna, and additional electrical measures are required.

WHIP RADIATION RESISTANCE

The power radiated by the antenna is equal to the radiation resistance times the square of the antenna current. The radiation resistance, R_r , of an electrically small antenna is given by:

$$R_r = 395 \times \left(\frac{h}{\lambda}\right)^2 \quad (8)$$

where

h = radiator height in meters,

λ = wavelength in meters = $300 / f$ in MHz.

Since radiation resistance of these electrically small antennas is a function of height, the antenna must be lengthened physically or electrically to increase it. Increasing radiation resistance improves efficiency, as shown next.

The efficiency of the antenna, η , equals the radiation resistance, R_r , divided by the resistive component of the feed point impedance, R_{fp} , which for actual antennas includes ground losses and losses in the antenna:

$$\eta = \frac{R_r}{R_{fp}} \times 100\% \quad (9)$$

(See the section on Ground Losses for more about mobile and portable "ground.") Since an

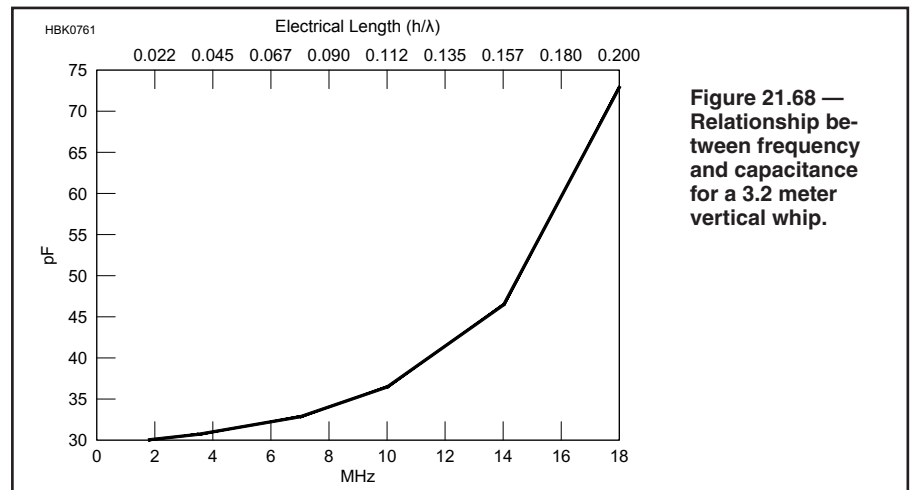

Figure 21.68 — Relationship between frequency and capacitance for a 3.2 meter vertical whip.

Table 21.11

Characteristics of an 8 foot Mobile Whip

f (MHz)	Loading L μH	R_c (Q=50) Ω	R_c (Q=300) Ω	R_r Ω	Feed R^* Ω	Matching L μH
Base Loading						
1.8	345	77	13	0.1	23	3
3.8	77	37	6.1	0.35	16	1.2
7.2	20	18	3	1.35	15	0.6
10.1	9.5	12	2	2.8	12	0.4
14.2	4.5	7.7	1.3	5.7	12	0.28
18.1	3.0	5.0	1.0	10.0	14	0.28
21.25	1.25	3.4	0.5	14.8	16	0.28
24.9	0.9	2.6	—	20.0	22	0.25
29.0	—	—	—	—	36	0.23
Center Loading						
1.8	700	158	23	0.2	34	3.7
3.8	150	72	12	0.8	22	1.4
7.2	40	36	6	3.0	19	0.7
10.1	20	22	4.2	5.8	18	0.5
14.2	8.6	15	2.5	11.0	19	0.35
18.1	4.4	9.2	1.5	19.0	22	0.31
21.25	2.5	6.6	1.1	27.0	29	0.29

R_c = loading coil resistance; R_r = radiation resistance.

*Assuming loading coil Q = 300, and including estimated ground-loss resistance.

electrically short antenna has a low radiation resistance, careful attention must be paid to minimizing losses in the antenna system that can greatly reduce the antenna's effectiveness.

WHIP CAPACITANCE

As we shorten an antenna to less than $\frac{1}{4}\lambda$, its radiation resistance decreases and the capacitance drops as shown in **Table 21.11**. **Figure 21.68** shows that capacitance is not very sensitive to frequency for h/λ less than 0.075.

The capacitance in pF of an electrically small antenna is given approximately by:

$$C = \frac{55.78 \times h}{[(\text{den1}) \times (\text{den2})]} \quad (10)$$

where

- (den1) = $(\ln(h/r) - 1)$,
- (den2) = $[1 - (f \times h/75)^2]$,
- ln = natural logarithm,
- r = conductor radius in meters, and
- f = frequency in MHz.

Radiation resistance rises in a nonlinear fashion, and the capacitance drops just as dramatically with an increase in the ratio h/λ . **Figure 21.68** can be used for estimating antenna capacitance for other heights and shows that capacitance is not very sensitive to frequency for h/λ less than 0.075 which occurs at 8 MHz in this case.

21.8.2 Coil-Loaded Whips

To bring an electrically short whip antenna to resonance, we must add inductance in the form of a loading coil. The coil can take many forms, and it may be placed almost anywhere along the length of the radiating element. It cancels out the capacitive reactance by introducing an equal but opposite inductive reactance. Some coils are mounted at the base of the mast — a base-loaded antenna — and some are mounted near the center (center-loaded) or the top (top-loaded).

Base-loaded whips are also popular for portable operation as described in the **Portable Station** section of the chapter **Assembling a Station**. The loading coil is very similar in size to those used for adjustable "screwdriver" mobile antennas, resulting in fairly low loss. Adjustment of the coil is made by sliding a metal collar or moving a tap contact along the coil. These antennas are typically installed with the feed point and loading coil at ground level, along with several radial wires. Base-loading trades efficiency for convenience of installation and reduced length as described in the following sections.

As the coil is moved higher, the radiation resistance increases (a good thing), but the necessary coil reactance also increases

Table 21.12

HF Mobile Antenna Comparison

Antenna Type	Length	Frequency Coverage	Efficiency	Mounting Difficulty	Matching Required
Simple Whip	< 11 ft	15 m & up	Excellent	Easy	No
Base-Loaded	9 to 10.6 ft	160 - 6 m	Fair to good	Average	Yes
Center-Loaded	9 to 10.5 ft	160 - 6 m	Good to excellent	Average	Yes
Top-Loaded	<9 ft	160 - 6 m	Fair	Average	No
Continuous Loading	< 7 feet	80 - 6 m	Poor to fair	Easy	No
Remote-tuned Small	< 7 feet	80 - 6 m	Poor to fair	Easy	No
Remote-tuned Large	9 to 10.5 ft	160 - 6 m	Excellent	Difficult	Yes

as do resistive losses in the coil. Therefore it becomes a balancing act, which requires a thorough understanding of the parameters involved, to choose the optimal coil location.

Table 21.11 lists the characteristics of an 8 foot (2.4 meter) mobile whip in both base-loaded and center-loaded configurations. The table shows the required loading coil inductance to bring the antenna to resonance on the different bands. The matching coil inductance is placed across the feed point to bring the impedance to 50 Ω .

Note that center-loading approximately doubles both the required inductance and the coil's resistive losses. The radiation resistance also increases, but only in that part of the antenna above the loading coil. If ground losses are included in the calculations, the coil's optimal position changes, but it is typically close to the center of the antenna.

It is important to note that the total amount of stray capacitance from the mounting hardware and proximity of the whip to the vehicle may be much higher depending on where and how the antenna is mounted. The higher the stray capacitance, the less efficient the antenna will be.

Table 21.12 compares different types of HF mobile antennas against an unloaded whip antenna. The simple whip is assumed to be a full-size $\frac{1}{4}$ wavelength. The effects of mounting are not included.

LOADING COIL Q

Antenna system Q is limited by the Q of the coil. The bandwidth between 2:1 SWR points of the system = $0.36 \times f/Q$. On 80 meters, the bandwidth of the 10.5 foot whip = $0.36 \times 3.5/200 = 6.3$ kHz. If we could double the Q of the coil, the efficiency would double and the bandwidth would be halved. The converse is also true. In the interest of efficiency, the highest possible Q should be used!

Loading coil Q is especially important on the lower HF bands where coil losses can exceed ground losses. The factors involved include wire size, wire spacing, length-to-diameter ratio and the materials used in constructing the coil. All of the factors interact with one another, making coil design a compromise — especially when wind loading and weight become major considerations.

Table 21.13

Suggested Loading Coil Dimensions

Req'd L (μ H)	Turns	Wire Size	Dia. (Inches)	Length (Inches)
700	190	22	3	10
345	135	18	3	10
150	100	16	2½	10
77	75	14	2½	10
77	29	12	5	4¼
40	28	16	2½	2
40	34	12	2½	4¼
20	17	16	2½	4¼
20	22	12	2½	2¾
8.6	16	14	2	2
8.6	15	12	2½	3
4.5	10	14	2	1¼
4.5	12	12	2½	4
2.5	8	12	2	2
2.5	8	6	2¾	4½
1.25	6	12	1¾	2
1.25	6	6	2¾	4½

In general, the larger the coil, the higher the Q. The more mass within the field of the coil (metal end caps for example) the lower the Q. Short, fat coils are better than long, skinny ones. However, the coil's length-to-diameter ratio (L/D) for the highest Q increases as the inductance increases. It ranges from 1:1 on the upper HF bands to as much as 4:1 on the lower bands where the inductance is large. Practical mechanical considerations for coils with large reactance values above 1000 Ω (160 meter coils for example) require the length-to-diameter ratio to increase, which lowers Q. **Table 21.13** suggests loading coil dimensions that maximize Q.

Another significant factor arises from high Q. Let's assume that we deliver 100 W on 80 meters to the 7.43 Ω at the antenna terminals. The current is 3.67 A and flows through the 1375 Ω reactance of the coil, giving rise to $1375 \times 3.67 = 5046$ V_{RMS} (7137 V_{peak}) across the coil! This is a significant voltage and may cause arcing if the coil is wet or dirty.

With only 30.6 pF of antenna capacitance, the presence of significant stray capacitance at the antenna base shunts current away from the antenna. RG-58 coax presents about

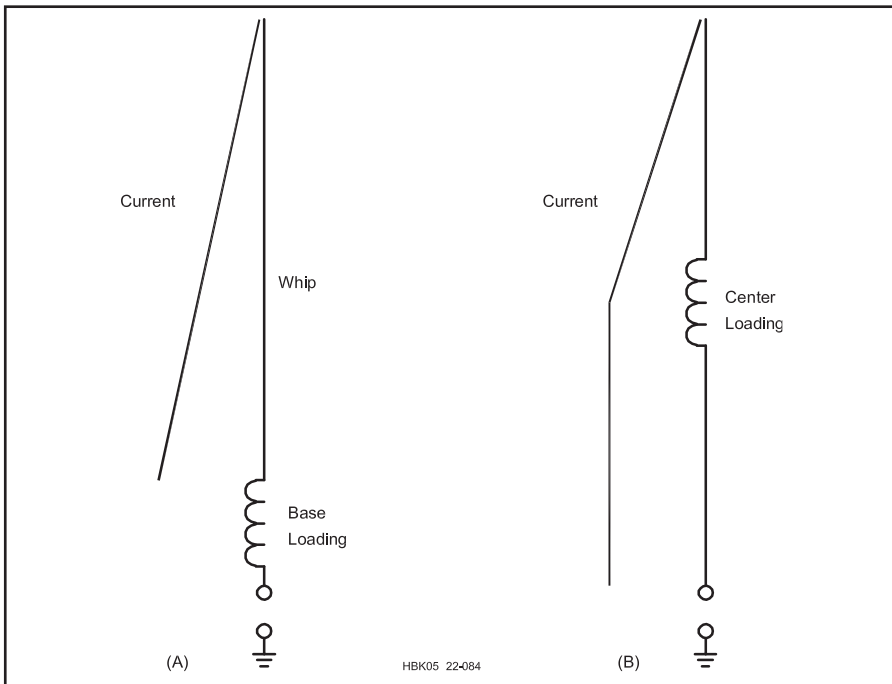

Figure 21.69 — Relative current distribution on a base-loaded antenna is shown at A and for a center-loaded antenna at B.

21 pF/foot. A 1.5 foot length of RG-58 would halve the radiation efficiency of our example antenna. For cases like the whip at 3.5 MHz, the matching network has to be right at the antenna!

21.8.3 Base vs Center vs Continuous Loading

There are a few important aspects to be kept in mind when selecting or building an HF mobile antenna. As the antenna becomes longer, less loading inductance is required and the coil Q can become higher, improving efficiency. Also, the longer the antenna, the better the mounting location has to be in order to optimize efficiency. We'll cover mounting and efficiency later. (See the section on Physically Short Verticals earlier in this chapter for more on loading vertical antennas.)

Placing the loading coil at the base results in the current distribution shown in **Figure 21.69**. If we move the coil to the center, the current curve looks like the one in **Figure 21.69**. The location of the optimal position between the two extremes depends on the ground losses, and to a lesser degree on loading coil Q and overall length. For example, if the ground losses were zero, the best position would be at the bottom. As the ground losses increase, the optimal position gets closer to the center. If the ground losses are high enough, the optimal position is in the top one-third of the antenna's length, but efficiency is very poor.

Center-loading increases the current in the lower half of the whip, as shown in **Figure**

21.69. Capacitance for the section above the coil can be calculated just as for the base-loaded antenna. This permits calculation of the loading inductance. The center-loaded antenna is often operated without any base matching, in which case the resistive component can be assumed to be $50\ \Omega$ for purposes of calculating the current rating and selecting wire size for the inductor. The reduced size of the top section results in reduced capacitance, which requires a much larger loading inductor.

Because of the high value of inductance required for center-loading, high-Q coils are very large. The large wind resistance necessitates a very sturdy mount for operation at highway speed. One manufacturer of this type of coil does not recommend its use in rain or inclement weather. The higher Q of these large coils results in a lower feed point impedance, necessitating the use of a base matching element in the form of either a tapped inductor or a shunt capacitor to match to $50\ \Omega$. (See the following section on Mobile HF Antenna Matching.) Another manufacturer places the coil above the center and uses a small extendable whip or wand for tuning.

Antennas known by the trade name "Hamsticks," shown in **Figure 21.70**, aren't entirely continuously loaded. Instead, a small diameter enameled wire loosely wound around a fiberglass tube forms the base section of the antenna. Approximately half way up the antenna, the wire is close wound to form a lumped-element loading coil, and a metal whip or stinger is attached at the top to complete the whip. A heat-shrink sleeve covers the wound



Figure 21.70 — Continuously-loaded whip antennas are short and lightweight. The base section consists of a fiberglass tube wound with wire to form the loading inductor. At the top of the base section the length of a steel whip or stinger can be adjusted to bring the antenna to resonance. [Joel Hallas, W1ZR, photo]

section of the antenna. The stinger's length can be adjusted to tune the antenna to the desired operating frequency.

In recent years, these lightweight antennas have become very popular. Their input impedance is near $50\ \Omega$ in part because of their low-Q base and loading coil sections. Thus they don't require matching once the length of the top whip or stinger is adjusted. They are light in weight (about a pound), short in length (typically 6 to 8 feet), and thus easy to mount. For temporary use, easy mounting may be more important than high efficiency. This type of antenna is most effective on

Designing a Base Loading System

This design procedure was contributed by Jack Kuecken, KE2QJ. To begin, estimate the capacitance, capacitive reactance and radiation resistance as shown at the beginning of this section. Then calculate the expected loss resistance of the loading coil required to resonate the antenna. There is generally additional resistance amounting to about half of the coil loss, which must be added in. As a practical matter, it is usually not possible to achieve a coil Q in excess of 200 for such applications.

Using the radiation resistance plus 1.5 times the coil loss and the power rating desired for the antenna, one may select the wire size. For high efficiency coils, a current density of 1000 A/inch² is a good compromise. For the 3.67 A of the example we need a wire 0.068 inch diameter, which roughly corresponds to #14 AWG. Higher current densities can lead to a melted coil.

Design the coil with a pitch equal to twice the wire diameter and the coil diameter approximately equal to the coil length. These proportions lead to the highest Q in air core coils.

The circuit of **Figure 21.A2** will match essentially all practical HF antennas on a car or truck. The circuit actually matches the antenna to 12.5 Ω, and the transformer boosts it up to 50 Ω. Actual

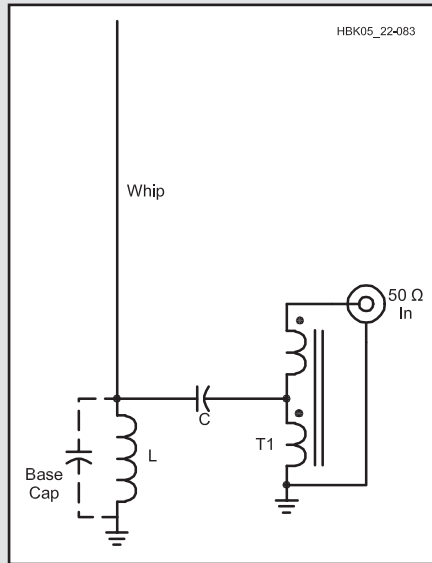

Figure 21.A2 — The base-matched mobile whip antenna

losses alter the required values of both the shunt inductor and the series capacitor. At a frequency of 3.5 MHz with an antenna impedance of $0.55 - j1375 \Omega$ and a base capacitance of 2 pF results in the values shown in **Table 21.B**. Inductor and capaci-

Table 21.B

Values of L and C for the Circuit of Figure 21.A4 on 3.5 MHz

Coil Q	L (μH)	C (pF)	System Efficiency (%)
300	44	11.9	8.3
200	29.14	35	3.72
100	22.2	58.1	1.4

tor values are highly sensitive to coil Q. Furthermore, the inductor values are considerably below the 62.5 μH required to resonate the antenna.

This circuit has the advantage that the tuning elements are all at the base of the antenna. The whip radiator itself has minimal mass and wind resistance. In addition, the radio is protected by the fact that there is a dc ground on the radiator, so any accidental discharge or electrical contact is kept out of the cable and radio. Variable tuning elements allow the antenna to be tuned to other frequencies.

Connect the antenna, L and C. Start with less inductor than required to resonate the antenna. Tune the capacitor to minimum SWR. Increase the inductance and tune for minimum SWR. When the values of L and C are right, the SWR will be 1:1.

20 meters and higher frequency bands.

The wound base section of these antennas is a very weak radiator, acting more like a transmission line or distributed element than a linear radiating element. The long and thin coil has low Q, as well, increasing antenna loss. The close-wound section acts like a lumped element and does not radiate.

21.8.4 Top-Loaded Whips

In the interests of efficiency, electrical length matters because radiation resistance increases as the square of electrical length. Higher radiation resistance in a mobile antenna results in higher efficiency. All else being equal, a 12 foot antenna will have 4 times the radiation resistance than one 6 feet long. As pointed out above, the maximum physical height should be less than 13.5 feet (4.1 meters). As discussed in this chapter's section on Physically Short Antennas, one way to increase the electrical length but not the physical length, is top-loading. A mobile HF antenna is top-loaded by using a *capacitance hat* or "cap hat."

As their name implies, cap hats add capacitance at the top of the antenna, above any loading coil. This increases radiation resistance by

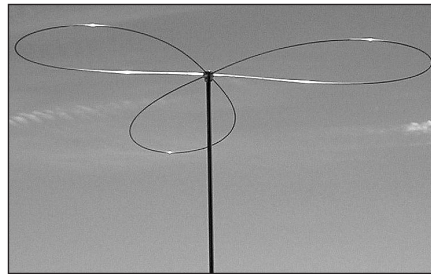

Figure 21.71 — A typical capacitance hat or "cap hat" added at the top of a mobile whip antenna. The antenna is a Scorpion (scorpionantennas.com).

as much as four times under ideal conditions, but at the expense of increased weight, wind loading and complexity. Not all antennas, especially small screwdriver types, are sturdy enough to support a large cap hat. For those that are, or if the antenna can be guyed or stiffened, cap hats offer increased efficiency and bandwidth.

The actual placement of the cap hat is important, too. If mounted too close to the loading coil, efficiency is lower than with no cap hat at all. Thus, the best mounting location is at the very top of the antenna.

The physical design of the cap hat is limited by practical concerns. The largest are approximately 3 feet in diameter and require additional bracing or guying of the antenna. Most are constructed of straight radial wires without an outer rim. The loop design shown in **Figure 21.71** is more efficient than straight wires, but tends to snag more on errant limbs. See the referenced *QEX* article by Griffith and the *QST* article by Clement for more on capacitance hats and top loading of mobile antennas.

21.8.5 Remotely Controlled HF Mobile Antennas

Remotely controlled (motorized) HF mobile antennas are commonly referred to as *screwdriver antennas*. Don Johnson, W6AAQ (SK), is credited by many as the father of the screwdriver antenna. His design was not the first motorized antenna, but he certainly popularized it. There are now over 50 commercial versions available.

They're called screwdrivers because the first examples used a stripped-down rechargeable electric screwdriver assembly to adjust the resonant frequency of the antenna. The motor turns a threaded rod in and out of a nut attached to the bottom of the coil. This in turn moves



Figure 21.72 — The screwdriver-style remotely-controlled whip antenna. A small motor in the base mast moves a coil past contacts at the top of the metal base section. The top whip section is attached to the top of the coil. As the coil moves out of the mast, more inductance is connected in series between the base section and top section. Screwdriver antennas are popular because they offer multiband coverage. [Joel Hallas, W1ZR, photo]

the coil in and out of the lower mast section. Contacts at the top of the mast slide on the outside of the coil, thus adjusting the resonance point. Position sensors may be used to keep track of the location of the coil tap. Nowadays, calling them screwdrivers is a bit of a misnomer as the electric screwdriver motors have been replaced with much more reliable gear motors.

There are several remotely controlled HF mobile antennas that don't change length as true screwdrivers do. Both base and center loaded models are available (see **Figure 21.72**). Whether or not they're more efficient is dependent on the factors discussed in the previous section, rather than the method used to adjust the coil.

RF CHOKES

The motors and position sensors of all remotely controlled antennas operate above vehicle body potential. The amount of RF

Determining the Radiation Efficiency of a Center Loaded Mobile Whip

We can measure the radiation efficiency by measuring ground wave field strength E (dB referenced to $\mu\text{V/m}$). For the average radio amateur, a field strength meter is not a part of the ham station gear. We can predict performance using readily available antenna modeling software (one of the many available versions of *NEC*), provided we have a measure of actual losses.

There are a number of loss parameters we do not know. We do not know the Q factor for the center loading coil (R_L), and we do not know the ground-induced loss resistance (R_g). In fact we do not know with certainty the radiation resistance (R_r), since the antenna sees an image of itself in the ground. *NEC* only gives us the sum of the various resistances.

$$R_{as} = R_r + R_C + R_g + R_L$$

R_C , the only parameter not discussed above, is the conductor loss resistance.

We need to know R_r if we are going to compute radiation efficiency, since radiation efficiency is given by:

$$\eta = \frac{R_r}{R_{as}}$$

So what do we do? We can measure R_{as} using the SWR analyzer, by adjusting the tuning so the reactance at the base of the antenna is equal to zero. We can then use *NEC* to predict the base impedance (resistive component) by changing the Q factor of the inductor so that R_{as} predicted equals R_{as} measured. We can then predict the ground field strength (dB $\mu\text{V/m}$) at say 100 m for a transmitter power of 1 kW. We reference this predicted field strength to that for an electrically small lossless vertical antenna (129.54 dB $\mu\text{V/m}$ at 100 m for 1 kW transmitter power — which corresponds to the commonly quoted value of 300 mV/m at 1 km). This gives us a pretty good estimate of the radiation efficiency of our mobile whip. — *Jack Belrose, VE2CV*

present on the leads depends on several factors, especially where and how the antenna is mounted and its overall (electrical) length. Thus the RF current coupled onto the leads must be minimized with an RF choke before entering the vehicle. An inadequate choke may result in erratic controller operation and possible interference with transceiver operation.

The choke should have an impedance of at least two orders of magnitude greater than the impedance of the circuit. In other words, at least 5 k Ω , and perhaps two or three times that in some cases (stubby antennas and poor mounting schemes are examples). Mix 31 ferrite split beads are ideal for this application, but it takes eight turns to obtain a 5 k Ω choking impedance. Depending on the wire size and insulation, you'll need to use the $\frac{1}{2}$ or $\frac{3}{4}$ inch ID cores. Snap-on ferrite beads are available from most amateur radio dealers. (More information on this type of RF choke may be found in the **RF Techniques** chapter.)

The choke shown in **Figure 21.73** consists of 13 turns of #18 AWG wire, wound on a $\frac{3}{4}$ inch ID, mix 31 split bead. It has an impedance of approximately 10 k Ω at 10 MHz. When winding the chokes, try not to overlap or twist the wires, as this reduces the effectiveness.

21.8.6 Ground Losses

High frequency mobile ground loss data first appeared in a 1953 issue of *QST*, in an article



Figure 21.73 — RF choke for screwdriver antenna control and power leads.

written by Jack Belrose, VE3BLW (VE2CV). Belrose said that the current flowing at the base of the antenna must be returned to the base of the antenna by currents induced in the ground beneath the radiator (antenna). These currents must be collected by the car body and through the capacitance of the car body to the ground. Since the maximum dimension of car body is considerably less than a quarter wavelength on most HF bands, only a portion of these currents will be collected by the car frame itself; the rest will be collected by ground currents flowing through the capacitance of the car to the ground. Since the ground is not lossless, quite a large loss resistance (R_g) is found.

Belrose points out that the accepted ground loss figure for HF mobile applications varies

between 12 Ω (for 80 meters) and 2 Ω (for 10 meters). However, these figures do not include stray capacitance from the mounting location and method. Stray capacitance has the same effect as ground losses: reduced efficiency. As a result, in the real world, ground losses can be double the accepted values, reducing an otherwise efficient antenna to mediocrity.

21.8.7 Antenna Mounting

PERMANENT OR TEMPORARY

There are many reasons to install any mobile antenna permanently on a vehicle. The decision to drill holes in sheet metal to mount antennas is hotly debated. While no-hole mounts can be used satisfactorily, it is best to look at all sides of the issue before installing any antenna.

A common concern about drilling a hole for an antenna mount is with regard to a leased vehicle. Leases don't necessarily preclude properly installed antenna mounting holes. Lease agreements are primarily concerned with body damage caused by accident or mistreatment. Properly installed NMO mounts, for example, are often acceptable. It's always prudent to ask before leasing the vehicle.

Drilled holes and waterproof mounts also help minimize common-mode current on the coaxial feed line. This helps reduce RFI to or from on-board computers and electrical devices. Aside from the hole itself, a permanent mount also minimizes damage to the finish.

Here is an important caveat to keep in mind: While the roof of a vehicle is a very good place to mount an antenna, more and more new vehicles are equipped with side curtain air bags. They typically are mounted along the edges of the headliner, including the rear seat area if there is one. The wiring to these devices is routed through any one (or more) of the roof pillars. Extra care is required when installing antennas in vehicles so equipped. If you are the least bit apprehensive about installing a roof-mounted antenna, seek professional help from your dealer or a qualified installer.

Mobile antenna mounting hardware runs the gamut from mundane to extravagant. Choosing the correct hardware is based on need as well as on personal preference. There are too many variables with respect to mounting HF mobile antennas on modern vehicles to cover in a short discussion. It is easier to explain what not to do and adapt those guidelines to your own personal circumstances. The antenna mount should:

- Be permanently mounted;
- Be strong enough to support the antenna;
- Have as much metal area under it as possible;
- Be well-grounded to the chassis or body;
- Not interfere with doors, trunks, or access panels; and
- Be removable with minimal damage to the vehicle.

Aside from maximizing performance by minimizing ground and stray capacitance losses, there are also safety reasons for using a permanent mount with HF antennas. If you need to use a temporary mount, use the multiple-magnet mounts for their superior holding strength. Any mobile HF antenna attached to a vehicle traveling at highway speed by a single-magnet mount is a tenuous situation at best.

TYPE OF MOUNT

The type of mount is dictated by several conditions. These include a decision whether or not to drill holes and the size, weight, and length of the antenna. If you want to operate HF mobile operation regularly, you are better off with a permanent mount. If you're not, a trunk lip, angle bracket, or license plate mount and a lightweight, continuously loaded antenna may meet your needs.

Ground plane losses directly affect a mobile antenna's efficiency. From this standpoint, mounts positioned high on the vehicle are preferred over a trailer hitch, bumper, or other locations that place the antenna where the vehicle body will be close to the radiating element.

The ground plane of a mobile vertical antenna begins where the coax shield connects. When the feed line shield couples to the vehicle body capacitively as in a mag-mount, or when the mass of the vehicle is far below the feed point (long extension sections attached to trailer hitch mounts), ground losses escalate dramatically. Running a ground strap to the nearest connecting point to the vehicle body does not eliminate ground losses. Remember

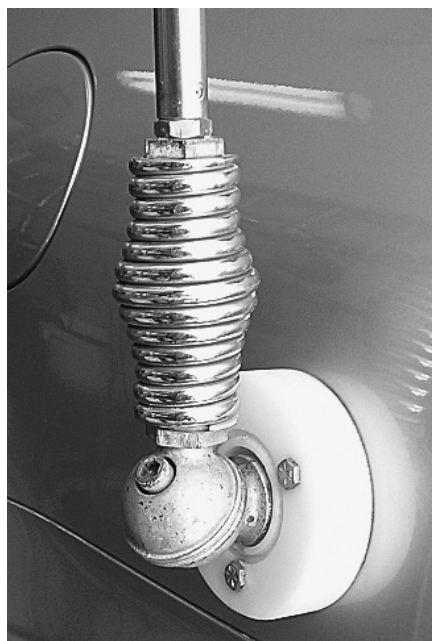

Figure 21.74 — A simple ball mount is sturdy but requires drilling holes in the vehicle body.

that the ground connection is part of the antenna system, and it is the efficiency of the whole system that is important.

While it is difficult to mount an HF antenna without at least part of the mast being close to the body, the coil must be kept free and clear or tuning problems and reduced efficiency will result. In some cases, vans and SUVs for example, front-mounting may become necessary to avoid excessive coil-to-body interaction.

One drawback to trunk lip and similar clip mounts is the stress imposed on them as the lids and doors are open and closed. In most cases, angle brackets that attach to the inner surfaces with screws are a better choice.

Sometimes, the only solution is a custom-made bracket like the one shown later in this chapter. Here too, the circumstances dictate the requirements. Keep in mind that removing permanently installed antenna mounts such as the ball mount shown in **Figure 21.74** will always leave some body damage, but temporary ones do, too. Only the severity is in question, and that's in the eyes of the beholder.

21.8.8 Mobile HF Antenna Matching

Modern solid-state transceivers are designed for loads close to 50 Ω impedance. Depending on the design of the antenna (primarily depending on coil position and Q), overall length, and the ground losses present, the input impedance is usually closer to 25 Ω but may vary from 18 Ω to more than 50 Ω . Note that a vehicle is an inadequate ground plane for any HF mobile antenna. Typical ground loss varies from 20 Ω (160 meters) to 2 Ω (10 meters). Stray capacitance losses may further increase the apparent ground losses.

It's important to remember two important facts. First, as the coil is moved past the center of the antenna toward the top, the coil's resistive losses begin to dominate, and the input impedance gets closer to 50 Ω . Second, short stubby antennas require more inductance than longer ones, which increases resistive losses in the coil (low Q). While no matching is required in either case, efficiency suffers and may actually drop below 1% on the lower bands. Another way to look at the situation is that an antenna with no matching required implies a low efficiency.

Ground loss, coil position, coil Q, mast size, whip size, and a few other factors determine the feed point impedance, which averages about 25 Ω for a typical quality antenna and mount. This represents an input SWR of 2:1, so some form of impedance matching is required for the transceiver. There are three ways to accomplish the impedance transformation: capacitive, transmission-line transformer and inductive matching as shown in **Figure 21.75**. Each has its own unique attributes and drawbacks.

Transmission line transformers, in this case

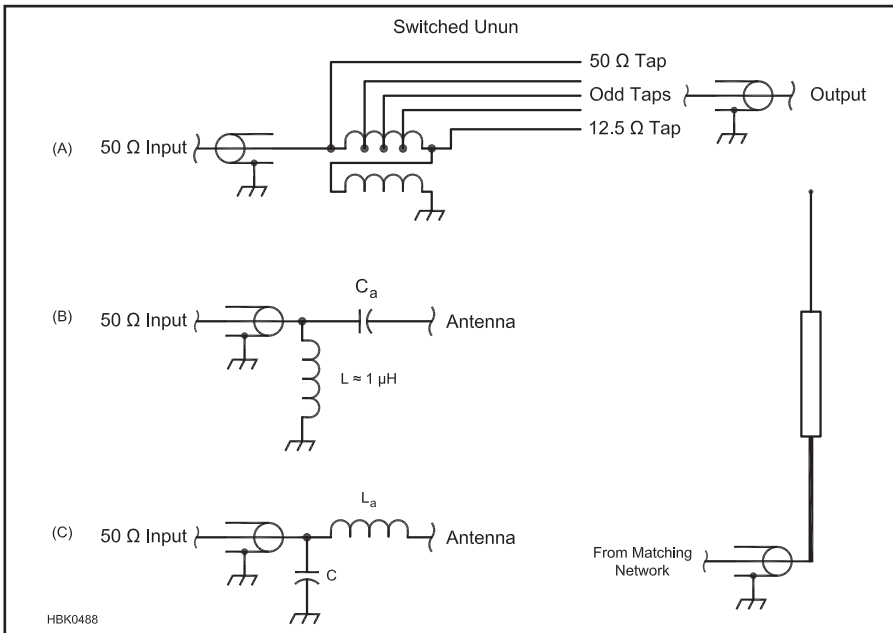

Figure 21.75 — A well-constructed and mounted HF mobile antenna will have an average input impedance around 25 Ω, requiring some matching to the feed line. The unun transmission line transformer (A) is a 4:1 configuration with taps added to match intermediate impedance values between 50 and 12.5 Ω. The high-pass L-network (B) uses some of the antenna’s capacitive reactance as part of the network, and the low-pass L-network (C) uses some of the antenna’s inductive reactance as part of the network. Both (A) and (B) result in an antenna at dc ground, an important safety issue.

an unun in Figure 21.75, do provide a dc ground for the antenna. They can be tapped or switched to match loads as low as a few ohms. Their broadband nature makes them ideal for HF mobile antenna matching. Since a remotely controlled HF mobile antenna’s input impedance varies over a wide range, transmission line transformers are best utilized for matching monoband antennas.

Inductive matching in Figure 21.75B borrows a little capacitance from the antenna (C_a) — the antenna is adjusted to a frequency slightly higher than the operating frequency, making the input impedance capacitive. This forms a high-pass L-network, which transforms the input impedance to the 50 Ω transmission line impedance. It is ideal for use with remotely controlled antennas, as its reactance increases with frequency. By selecting the correct inductance, a compromise can be reached such that the impedance transformation will result in a low SWR from 160 through 10 meters. The approximate value is 1 μH, but may vary between 0.7 and 1.5 μH.

Adjusting the shunt coil can be done in about 10 minutes without transmitting by using an antenna analyzer. (Full instructions for properly adjusting a shunt coil may be found at www.k0bg.com/coil.html.) Because no further adjustment is necessary, shunt coil matching is ideal for remotely controlled HF mobile antennas.

Capacitive matching in Figure 21.75 borrows a little inductance from the antenna

(L_a) — the antenna is adjusted to a frequency slightly lower than the operating frequency, making the input impedance inductive. This forms a low-pass L-network, which transforms the input impedance to the 50 Ω transmission line impedance. While it works quite well, it has two drawbacks. First, capacitive matching presents a dc ground for the antenna, which tends to increase the static levels on receive. Second, the capacitance changes with

frequency, so changing bands also requires a change in capacitance. This can be a nuisance with a remotely controlled antenna.

An important point should be made about dc grounding in addition to the static issue. If the antenna element should come in contact with a low-hanging high tension wire, or if lightning should strike it, dc grounding offers an additional level of protection for you and your transceiver.

21.8.9 Remotely Tuned Antenna Controllers

There are three basic types of remote controllers: manual, position sensing, and SWR sensing. Manual controllers consist of a DPDT center-off switch that changes the polarity of the current to the motor. Some commercial models include an interface with the radio that causes the radio to transmit a low-power carrier for tuning. Reading the SWR is left to the user. Some manual controllers incorporate a position readout to aid the operator in correctly positioning the antenna.

Position sensing controllers incorporate a magnet attached to the motor output shaft. The magnet opens and closes a reed switch. During set up, the antenna is set to one end of its range or the other. Then the resonant points are found (you have to do this yourself) and stored in multiple memory locations. As long as power is applied to the controller, a simple button push will move the antenna to a specific preset point. Some controllers use band or frequency data from a port on the radio and reset the antenna to the nearest preset based on that information.

SWR-sensing controllers either read data from the radio or from a built-in SWR bridge. Depending on the make and model, a push of the radio’s tuner button (or one on the control-



Figure 21.76 — A screwdriver antenna controller made to work with the IC-7000 transceiver.

ler) causes the radio to transmit at a reduced power setting. The controller then powers the antenna's tuning motor. When the preset SWR threshold is reached, the controller stops the transmission and shuts off the motor. **Figure 21.76** shows an example of a controller made to work with a specific transceiver.

Automatic controllers are far less distracting than manual ones. Most offer a parking function that collapses the coil of a screwdriver antenna into the mast (highest frequency position, lowest overall length). If you garage your vehicle, this is a welcome feature.

21.8.10 Efficiency

Length matters! All else being equal, a 9 foot antenna will be twice as efficient as a 6 foot antenna, because radiation resistance relates directly to the square of the physical length. Further, longer antennas require less reactance to resonate, hence coil Q is higher and resistive losses lower.

Mounting methodology matters! It is the mass under the antenna, not alongside, that counts. The higher the mounting, the less capacitive coupling there will be between the antenna and the surface of the vehicle, and the lower ground losses will be.

Project: Mounts for Remotely Tuned Antennas

Remotely tuned antennas have become very popular, but they all have one thing in common: they're difficult to mount. They require both a coaxial feed line and a dc power connection,

and no one makes a universal mount for them. The short, stubby ones aren't any more difficult to mount than a small whip antenna, but the "full-sized" ones (8 feet and longer) require special consideration.

These antennas are heavy (up to 18 pounds), so the mounting medium must be extra strong, and well anchored. As a result, many hams opt for a bumper or trailer hitch mount, even though the low mounting position reduces efficiency.

For some, efficiency is paramount, which dictates mounting the antenna as high as possible. Doing either low or high mounting often requires custom fabrication. The accompanying photos illustrate the two different strategies that show amateur radio ingenuity at its finest.

Figures 21.77 and **21.78** depict the mobile installation of Fokko Vos, PA3VOS. Except for a Hi-Q heavy-duty quick-disconnect, the complete mount was custom engineered by Fokko. The mount bolts to a frame extension, which in turn is bolted to the undercarriage using existing bolts. Note that the rear hatch may be opened without the antenna being removed. Had the trailer hitch been used, this would not be the case.

Figure 21.79 depicts installation on a Ford F350 based motor home owned by Hal Wilson, KE5DKM. Hal designed the bracket and had a local machine shop do the hard work. It is made of 1/4 inch, high-strength aluminum, and the seams are welded. A powder-coat finish tops off the fabrication.

Shown here during installation, the bracket just fits into the right-side hood seam. The piece

jutting out from the mount was to be used to further brace the mount. However, after all of the bolts were installed, additional bracing became unnecessary.

Project: Retuning a CB Whip Antenna

The most efficient HF mobile antenna is a full-size quarter-wavelength whip. Wouldn't it be nice if we could use one on every band? Alas, we cannot, but we can use one easily on 10 and 12 meters since the overall length will be less than 10 feet. If we start with a standard-length 102 inch whip and its base spring, we just need to shorten it a little for 10 meters and lengthen it a little for 12 meters. Here's how to do it.

The formula for calculating the length of a $\frac{1}{4} \lambda$ antenna in feet is $234/f$, where f is the frequency (MHz). Since the formula is for wire antennas and the whip is larger in diameter, the resulting length will be slightly too long. This is a good thing because it is easier to remove a little length than it is to add some. This makes tuning easier.

Using the formula, we discover the needed length for 10 meters (28.5 MHz) is 98.5 inches. Thus, we need to remove 3.5 inches and account for the length of the base spring (about 6 inches), for a total of 9.5 inches to be removed. This is best accomplished by filing a notch on opposite sides of the tip of the whip and snapping it in two. Protect your eyes when you do this, as shards and splinters can fly off the broken ends. If a fiberglass whip is being modified, clip the internal wire at the top of the remaining base section. Remove the plastic cap from the discarded top section and replace it over the new top of the antenna.

Depending on the mount used, the ac-



Figure 21.77 — The PA3VOS antenna mount easily supports a large screwdriver antenna and is offset to allow the hatch to open and close without removing the antenna.

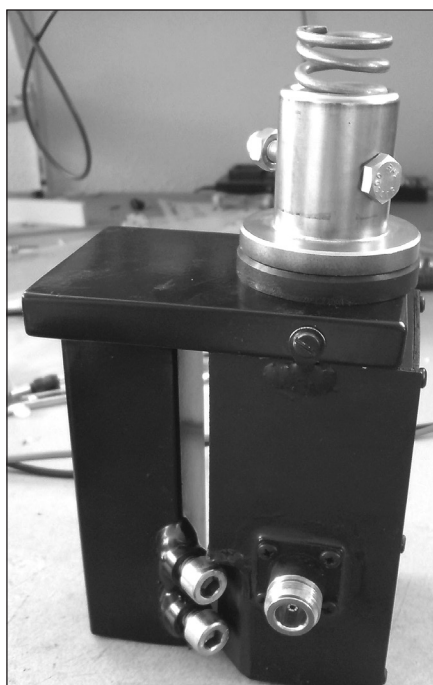

Figure 21.78 — A close-up of the PA3VOS mount.



Figure 21.79 — The KE5DKM bracket mounts under the hood of a motor home.

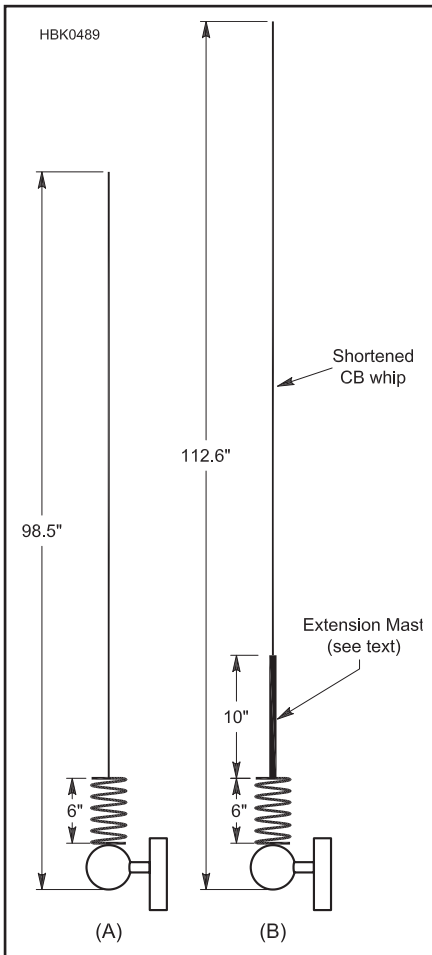

Figure 21.80 — CB whips are easily re-tuned for 10 meter (A) and 12 meter (B) mobile operation.

tual resonant frequency will be lower than 28.5 MHz as the mounts adds effective length. A standard CB antenna ball mount will easily support a whip. The finished antenna is shown in **Figure 21.80A**.

Once the antenna is mounted on the vehicle, simply trimming the overall length $\frac{1}{2}$ inch at a time will eventually produce a low SWR at your desired frequency.

LENGTHENING FOR 12 METER OPERATION

Lengthening a CB whip for 12 meters requires a little more work. Thankfully, there's an easy solution if you have a CB radio or truck stop near you. Wilson and other vendors sell short masts designed for the CB market. They have the requisite $\frac{3}{8} \times 24$ threads to accept a standard whip, and they come with a female-to-female coupler. The 10 inch model

is ideal for our use, and costs under \$10.

Using our formula $234/f$, the overall length needs to be 112.6 inches for 24.93 MHz. Adding 6 inches for the spring, 10 inches for the extension mast, and 102 inches for the whip gives us 118 inches. So we need to remove 5.4 inches from the whip. Then just trim off $\frac{1}{2}$ inch at a time as above to resonate the antenna. The finished antenna is shown in **Figure 21.80B**.

FINISHING UP

There are two more things to consider. If a metal whip was modified, you'll need to replace the corona ball at the tip of the antenna. It helps reduce static from corona discharge. It's held on by a set screw and has little effect on tuning. Most CB shops sell them.

The other consideration is ground loss. Theoretically, a $\frac{1}{4} \lambda$ vertical will have an input impedance of 36Ω . In a mobile installation, we have ground losses and stray capacitance losses in the mounting hardware. As a result, the real-world input impedance should be very close to 42Ω , yielding a rather low SWR and good efficiency.

21.9 VHF/UHF Mobile Antennas

The simple $\frac{1}{4} \lambda$, $\frac{1}{2} \lambda$, and $\frac{3}{8} \lambda$ ground-plane whips are the most common VHF/UHF mobile antennas. Collinear antennas with higher gain are available. However, high gain and the lower radiation angle that goes with it isn't always a desirable attribute.

When using repeaters in urban areas, where higher angles of radiation are preferred, you're typically better off with a unity-gain antenna — a $\frac{1}{4} \lambda$ whip. It all depends on the HAAT (height above average terrain) of the repeater being used with respect to the mobile station's HAAT. In mountainous areas you're always better off with a unity gain antenna, as the repeaters are much higher in elevation than the mobile station is.

If you're working simplex and living in a suburban or rural area, a high-gain antenna might have a slight edge. However, where, and how the antenna is mounted is more important than gain. A $\frac{1}{4} \lambda$ ground plane mounted in the center of the roof will typically outperform a gain antenna mounted on the trunk lid.

Sturdiness is also an important attribute,

given the unintended abuse to which mobile antennas are subjected. The simple quarter-wave ground plane has the advantage here, as it isn't much more than a springy piece of wire. If you look closely at some of the higher-gain antennas, you'll notice they have very small phasing coils, usually held together by small set screws. Hit one hard enough with a low-hanging limb and your antenna will break, whereas a simple quarter-wave whip will only bend. A little straightening and you're back on the air.

21.9.1 VHF/UHF Mobile Antenna Mounts

Without doubt, the best VHF/UHF mobile mount ever devised is the NMO (New Motorola) shown in **Figure 21.81**. When properly installed in vehicle sheet metal, the mount will not leak even when the antenna is removed for car washing. SO-239 and threaded or snap-in mounts often leak even with the antenna attached.

Glass-mounted antennas are rather lossy, especially at lower VHF frequencies (2 meters). Many new vehicles use window glass with a metallic, anti-glare (passivated) coating that interferes with capacitive coupling through the glass. These antennas also transfer mechanical abuse to the glass, risking breaking the glass the antenna is mounted on.

MOUNTING LOCATION

As mentioned above, the center of the roof is an ideal mounting location for a VHF/UHF antenna. However, many mobile operators share a reluctance to drill the proper mounting holes, fearing that doing so will depreciate the value of the vehicle. Instead, they rely on a mag-mount, which has its own set of negatives including where and how to route the coax cable into the vehicle. They tend to collect metallic road debris, primarily brake pad dust, marring and scratching the painted surface under them, often causing more damage than would the hole for an NMO mount. For these reasons alone, mag-mounts should

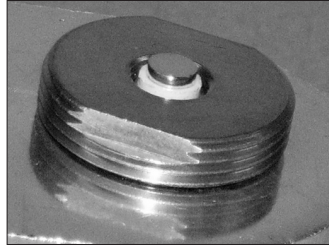
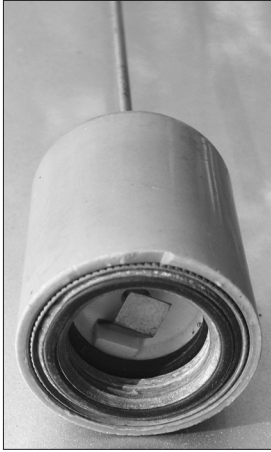

Figure 21.81 — The NMO (New Motorola) mount is widely used for VHF and UHF mobile antennas. It is available in mag-mount, trunk and lip mount and through-body mounting styles.



Figure 21.82 — The halo is a popular horizontally polarized mobile antenna for 6 meters through 70 cm. This version was made by Jerry Clement, VE6AB, and the construction article is available online (see text).

only be used for temporary installations, such as emergency communication. Paint scratches can be avoided during temporary operation by using a Tyvek pad under the magnet. Tyvek is a tough material used for envelopes, and other similar material will work as well.

Roof mounting has a few caveats. Modern vehicle roofs have strengthening supports to protect the occupants should the vehicle roll-over due to a crash. Do not drill through these supports!

The various side pillars supporting the roof contain wiring for lighting, side airbags, and other accessories, which can make routing of the coax difficult. If you're at all reticent about roof mounting, see a dealer or professional installer.

As an alternative, a trunk lip mount may fit the bill. However, they too have some drawbacks. They're stressed every time the trunk is opened or closed, and tend to work loose over time. Thus regular maintenance is required to assure a good electrical ground to the trunk lid. In any case, do not sand the paint down to bare metal, as this removes the zinc undercoating which in turn promotes rust. It is also important to bond across the trunk hinges to assure a good ground.

Angle brackets work well, too. They're thin enough to fit into the seam of hoods, trunk lids, and back hatches. Coax routing under or around the weather seals can be a problem with the latter two.

ADJUSTING SWR

Setting the SWR of a VHF/UHF antenna is an important installation procedure, but not

one to worry about unless the SWR suddenly changes significantly. Unlike the HF bands, most VHF antennas will cover the whole band segment without the need to retune. That is to say, the SWR will be low across the FM portion of the respective bands. An in-line SWR meter is generally not required, as the vertically polarized antenna is not intended to be used in the weak-signal portion of the bands where horizontal polarization is the norm.

21.9.2 VHF/UHF Mobile Antennas for SSB and CW

Operating SSB and CW on 6 meters, 2 meters, and 70 cm offers some exciting prospects for all license classes. While FM communications on the VHF bands are often considered line-of-site, propagation *beyond* line-of-site is common, as discussed in the **Propagation of Radio Waves** chapter.

Modern mobile SSB/CW transceivers usually output 100 W PEP on 6 meters and at least 50 W PEP on 2 meters and 70 cm. Under good band conditions using horizontally polarized antennas, *beyond* line-of-sight distances can exceed 200 miles even without any sky-wave or tropospheric scatter present!

There's a catch, however. FM communications utilize vertically polarized antennas. Vertical polarization can be used for SSB and CW, but depending on the propagation path, signal strength from a vertically polarized mobile antenna can have a disadvantage of up to 20 dB compared to a horizontally polarized antenna due to cross-polarization.

Fortunately, horizontally polarized antennas are of manageable size on the VHF and UHF bands, although they are not as simple to construct as vertically polarized whips. Dipoles and small beams present too much wind resistance to withstand the normal mobile environment. The usual solution is a loop antenna.

Figure 21.82 shows a horizontally polarized 6 meter loop called a *halo* that was made by Jerry Clement, VE6AB. (Complete construction plans are available in his article "6 Meter halo Antenna for DXing" in the February 2017 issue of *QST* which is available in this book's online material.) Square versions, such as those commercially available from M² Antenna Systems (www.m2inc.com), are called *squalos*. Both have a roughly omnidirectional pattern. The "Big Wheel" design is another option, and the article "A New Spin on the Big Wheel" by L.B. Cebik, W4RNL, and Bob Cerreto, WA1FXT, from the March 2008 issue of *QST* is included with the online content. Equivalent antennas for 2 meters and 70 cm are common. Mounting loop antennas on a vehicle can be less cumbersome than mounting an HF antenna because they don't require a ground plane. A simple hitch-mounted mast will suffice, with no body holes needed!

21.10 VHF/UHF Antennas

Improving an antenna system is one of the most productive moves open to the VHF enthusiast. It can increase transmitting range, improve reception, reduce interference problems and bring other practical benefits. The work itself is by no means the least attractive part of the job. Even with high-gain antennas, experimentation is greatly simplified at VHF and UHF because an array is a workable size, and much can be learned about the nature and adjustment of antennas. No large investment in test equipment is necessary.

Whether we buy or build our antennas, we soon find that there is no one *best* design for all purposes. Selecting the antenna best suited to our needs involves much more than scanning gain figures and prices in a manufacturer's catalog. The first step should be to establish priorities for the antenna system as a whole. Once the objectives have been sorted out in a general way, we face decisions on specific design features, such as polarization, length and type of transmission line, matching methods, and mechanical design.

21.10.1 Gain

As has been discussed previously, shaping the pattern of an antenna to concentrate radiated energy, or received signal pickup, in some directions at the expense of others is the only possible way to develop gain. Radiation patterns can be controlled in various ways. One is to use two or more driven elements, fed in phase. Such arrays provide gain without markedly sharpening the frequency response, compared to that of a single element. More gain per element, but with some sacrifice in frequency coverage, is obtained by placing parasitic elements into a Yagi array.

21.10.2 Radiation Pattern

Antenna radiation can be made omnidirectional, bidirectional, practically unidirectional, or anything between these conditions. A VHF net operator may find an omnidirectional system almost a necessity, but it may be a poor choice otherwise. Noise pickup and other interference problems tend to be greater with omnidirectional antennas. Maximum gain and low radiation angle are usually prime interests of the weak-signal DX aspirant. A clean pattern with lowest possible pickup and radiation off the sides and back may be important in high-activity areas, where the noise level is high, or for challenging modes like EME (Earth-Moon-Earth).

21.10.3 Height Gain

In general, the higher a VHF antenna is installed, the better the results. If raising the

antenna clears its view over nearby obstructions, it may make dramatic improvements in coverage. Within reason, greater height is almost always worth its cost, but height gain must be balanced against increased transmission line loss. Line losses can be considerable at VHF and above, and they increase with frequency. The best available line may be none too good if the run is long in terms of wavelength. Consider line losses in any antenna planning.

21.10.4 Physical Size

A given antenna design for 432 MHz, say a 5-element Yagi on a 1λ boom, will have the same gain as one for 144 MHz, but being only one-third the size it will intercept only one-ninth as much energy in receiving. Thus, to be equal in communication effectiveness, the 432 MHz array should be at least equal in physical size to the 144 MHz one, requiring roughly three times the number of elements. With all the extra difficulties involved in going higher in frequency, it is better to be on the big side in building an antenna for the UHF bands.

21.10.5 Polarization

Whether to position the antenna elements vertically or horizontally has been a question since early VHF operation. Originally, VHF communication was mostly vertically polarized, but horizontal gained favor when directional arrays became widely used. Tests of signal strength and range with different polarizations show little evidence on which to set up a uniform polarization policy. On long paths there is no consistent advantage, either way. Shorter paths tend to yield higher signal levels with horizontal in some kinds of terrain. Man-made noise, especially ignition interference, tends to be lower with horizontal polarization. Vertically polarized antennas, however, are markedly simpler to use in omnidirectional systems and in mobile work, resulting in a standardization on vertical polarization for mobile and repeater operation on FM and for digital communications. Horizontal polarization is the standard for weak signal VHF and UHF operation. (Circular polarization is preferred for satellite work, as described below.) A loss in signal strength of 20 dB or more can be expected with cross-polarization so it is important to use antennas with the same polarization as the stations with which you expect to communicate.

21.10.6 Circular Polarization

Polarization is described as *horizontal* or *vertical*, but these terms have no meaning once the reference of the Earth's surface is

lost. Many propagation factors can cause polarization change — reflection or refraction and passage through magnetic fields (Faraday rotation), for example. Polarization of VHF waves is often random, so an antenna capable of accepting any polarization is useful. Circular polarization, generated with helical antennas or with crossed elements fed 90° out of phase, will respond to any linear polarization.

The circularly polarized wave in effect threads its way through space, and it can be left- or right-hand polarized. These polarization senses are mutually exclusive, but either will respond to any plane (horizontal or vertical) polarization. A wave generated with right-hand polarization, when reflected from the moon, comes back with left-hand polarization, a fact to be borne in mind in setting up EME circuits. Stations communicating on direct paths should have the same polarization sense.

Both senses can be generated with crossed dipoles, with the aid of a switchable phasing harness. With helical arrays, both senses are provided with two antennas wound in opposite directions.

21.10.7 Transmission Lines

The most common type of transmission line at VHF through the low microwave bands is unbalanced coaxial cable. Small coax such as RG-58 or RG-59 should never be used in VHF work if the run is more than a few feet. Half-inch lines (RG-8 or RG-11) work fairly well at 50 MHz, and runs of 50 feet or less are acceptable at 144 MHz. Lines with foam rather than solid insulation have about 30% less loss. Low-loss cable is required for all but the shortest runs above 222 MHz, and *waveguide* is used on microwave frequencies. (See the **Transmission Lines** chapter for a discussion of waveguides.)

Solid aluminum-jacketed *hardline* coaxial cable with large inner conductors and foam insulation are well worth the cost. Hardline can sometimes even be obtained for free from local Cable TV operators as *end runs* — pieces at the end of a roll. The most common CATV variety is $\frac{1}{2}$ inch OD 75 Ω hardline. Hardline is considered *semi-rigid* in that it can be bent, but only with a large radius to avoid kinking, repeated bending should be avoided.

Waterproof commercial connectors for hardline are fairly expensive, but enterprising amateurs have *home-brewed* low-cost connectors. If they are properly waterproofed, connectors and hardline can last almost indefinitely. See *The ARRL Antenna Book* for details on connectors and techniques for working with hardline.

Properly-built open-wire line can operate with very low loss in VHF and even UHF installations. A line made of #12 AWG wire, spaced $\frac{3}{4}$ inch or less with Teflon spreaders and running essentially straight from antenna to station, can be better than anything but the most expensive hardline at a fraction of the cost. Line loss under 2 dB per 100 feet at 432 MHz is readily obtained. This assumes the use of high-quality baluns to match into and out of the balanced line, with a short length of low-loss coax for the rotating section from the top of the tower to the antenna. Such an open-wire line could have a line loss under 1 dB at 144 MHz.

Effects of weather on transmission lines should not be ignored. A well-constructed open-wire line works well in nearly any weather, and it stands up well. TV-type twin-lead is almost useless in heavy rain, wet snow, or icing conditions. The best grades of coax and hardline are impervious to weather. They can be run underground, fastened to metal towers without insulation, or bent into almost any convenient position with no adverse effects on performance. However, beware of bargain coax. Lost transmitter power can be made up to some extent by increasing power, but once lost in the transmission line a weak signal can never be recovered in the receiver.

21.10.8 Impedance Matching

Theory and practice in impedance matching are discussed in detail in the **Transmission Lines** chapter, and in theory at least are the same for frequencies above 50 MHz. Practice may be similar, but physical size can be a major modifying factor in choice of methods.

DELTA MATCH

Probably the first impedance match was made when the ends of an open line were fanned out and tapped onto a half-wave antenna at the points of most efficient power transfer, as in **Figure 21.83A**. Both the side length and the points of connection either side of the center of the element must be adjusted for minimum reflected power in the line, but the impedances need not be known. The delta makes no provision for tuning out reactance, so the length of the dipole is pruned for best SWR.

Once thought to be inferior for VHF applications because of its tendency to radiate if adjusted improperly, the delta has come back to favor now that we have good methods for measuring the effects of matching. It is very handy for phasing multiple-bay arrays with low-loss open lines, and its dimensions in this use are not particularly critical.

GAMMA MATCH

The gamma match is shown in **Figure 21.83C** and is covered in more detail in the

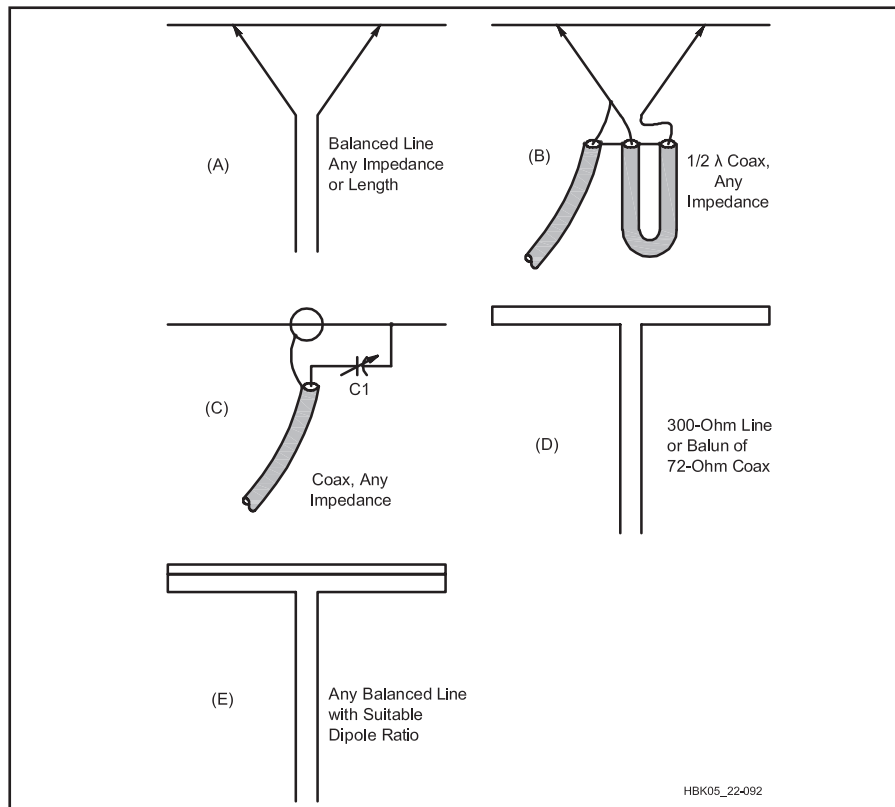

Figure 21.83 — Matching methods commonly used in VHF antennas. In the delta match, **A** and **B**, the line is fanned out to tap on the dipole at the points of best impedance match. The gamma match, **C**, is for direct connection of coax. **C1** tunes out inductance in the arm. Folded dipole of uniform conductor size, **D**, steps up antenna impedance by a factor of four. Using a larger conductor in the unbroken portion of the folded dipole, **E**, gives higher orders of impedance transformation.

preceding section on HF Yagi antennas and in the **Transmission Lines** chapter. The center of a half-wave dipole being electrically neutral, the outer conductor of the coax is connected to the element at this point, which may also be the junction with a metallic or non-conductive boom. The inner conductor is connected to the element at the matching point. Inductance of the connection to the element is canceled by means of **C1**. Both the point of contact with the element and the setting of the capacitor are adjusted for minimum SWR using an antenna analyzer or SWR bridge.

The capacitor **C1** can be a variable unit during adjustment and can then be replaced with a suitable fixed unit when the required capacitance value is found. Maximum capacitance should be about 100 pF for 50 MHz and 35 to 50 pF for 144 MHz. The capacitor and arm can be combined with the arm connecting to the driven element by means of a sliding clamp, and the inner end of the arm sliding inside a sleeve connected to the inner conductor of the coax. It can be constructed from concentric pieces of tubing and insulated by plastic sleeving or shrink tubing. RF voltage across the capacitor is low once the match is

adjusted properly, so with a good dielectric insulation presents no great problem. A clean, permanent, high-conductivity bond between arm and element is important, as the RF current is high at this point.

Because it is inherently somewhat unbalanced, the gamma match can sometimes introduce pattern distortion, particularly on long-boom, highly directive Yagi arrays. The T-match, essentially two gamma matches in series creating a balanced feed system, has become popular for this reason. (See the preceding discussion on T-matches in the HF Yagi section.) A coaxial balun like that shown in **Figure 21.83B** is used from the balanced T-match to the unbalanced coaxial line going to the transmitter. To maintain a symmetrical pattern, the feed line should be run along the antenna boom at the centerline of the elements to the mast. A choke balun is often used to minimize currents that might be induced on the outer surface of the feed line shield.

FOLDED DIPOLE

The impedance of a half-wave dipole feed point at its center is 72 Ω . If a single conductor of uniform size is folded to make a half-wave

dipole, as shown in Figure 21.83D, the impedance is stepped up four times. Such a folded dipole can thus be fed directly with 300 Ω line with no appreciable mismatch. Coaxial feed line of 70 to 75 Ω impedance may then be used with a 4:1 impedance transformer. Higher impedance step-up can be obtained if the unbroken portion is made larger in cross-section than the fed portion, as in Figure 21.83E. The folded dipole is discussed further in the *ARRL Antenna Book*.

21.10.9 Baluns and Impedance Transformers

Conversion from balanced loads to unbalanced lines, or vice versa, can be performed with electrical circuits, or their equivalents made of coaxial line. A balun made from flexible coax is shown in Figure 21.84A. The looped portion is an electrical half-wave. This type of balun gives an impedance step-up of 4:1, 50 to 200 Ω, or 75 to 300 Ω typically. (See the **RF Techniques** and **Transmission Lines** chapters for a detailed discussion of baluns and impedance transformers.)

The physical length of the line section depends on the propagation factor of the line used, so it is best to check its resonant frequency, as shown at B. One end of the line is left open and an antenna analyzer is used to find the lowest frequency at which the impedance at the other end of the line is a minimum, the frequency at which the section of line is $\frac{1}{4} \lambda$ long. Multiply the frequency by two to find the frequency at which the section is $\frac{1}{2} \lambda$ long.

Coaxial baluns giving a 1:1 impedance transfer are shown in Figure 21.85. The coaxial sleeve, open at the top and connected to the outer conductor of the line at the lower end (Figure 21.85A) is the preferred type. A conductor of approximately the same size as the line is used with the outer conductor to form a quarter-wave stub, in Figure 21.85B. Another piece of coax, using only the outer conductor, will serve this purpose. Both baluns are intended to present a high impedance to any RF current that might otherwise tend to flow on the outer conductor of the coax. Choke baluns made of ferrite beads of the proper material type or mix may also be used. (See the **RF Techniques** chapter for information about ferrite use at VHF and UHF.)

Project: Simple, Portable Ground-Plane Antenna

The ground-plane antenna, shown in Figure 21.86, uses a female chassis-mount connector to support the element and two radials. With only two radials, it is essentially two dimensional, which makes it easier to store when not in use. UHF connectors work well for 144 and 222 MHz, but you may prefer to use Type N connectors. N connectors

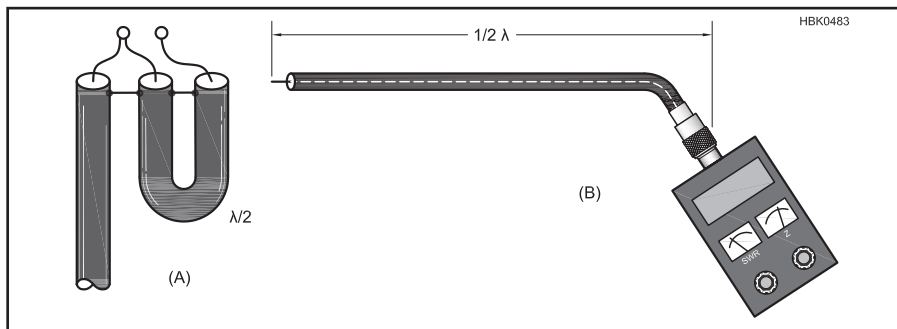

Figure 21.84 — Conversion from unbalanced coax to a balanced load can be done with a half-wave coaxial balun. A. The half-wave balun gives a 4:1 impedance step up. Electrical length of the looped section should be checked with an antenna analyzer with the far end of the line open, as in B. The lowest frequency at which the line impedance is a minimum is the frequency at which the line is $\frac{1}{4} \lambda$ long. Multiply that frequency by two to obtain the $\frac{1}{2} \lambda$ frequency.

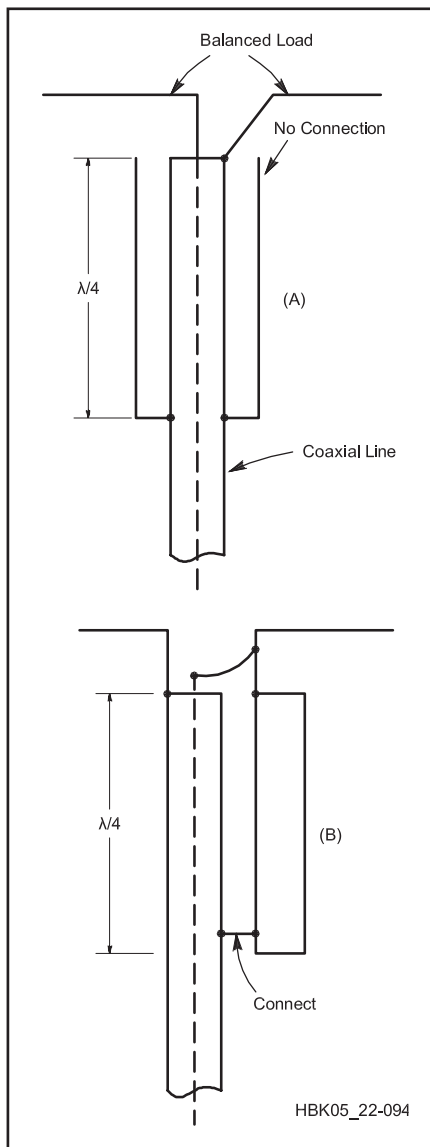

Figure 21.85 — The balun conversion function, with no impedance change, is accomplished with quarter-wave lines, open at the top and connected to the coax outer conductor at the bottom. The coaxial sleeve shown at A is preferred.

are recommended for 440 MHz and higher frequencies. BNC connectors can be used for the shorter antennas on 915 and 1280 MHz but are not particularly sturdy.

If the antenna is sheltered from weather, copper wire is sufficiently rigid for the radiating element and radials. Antennas exposed to the wind and weather can be made from brazing rod, which is available at welding supply stores. Alternatively, #12 or #14 AWG copper-clad steel wire could be used to construct this antenna.

To eliminate sharp ends, it's a good idea to bend the element and radial ends into a circle or to terminate them with a crimp terminal, as in Figure 21.87. The crimp terminal approach is easier with stiff wire. Crimp and then solder the terminal to the wire. Make the overall length of the element and radials the same as shown in Figure 21.86, measuring to the outer tip of the loop or terminal.

Radials may be attached directly to the mounting holes of the coaxial connector. Bend a hook at one end of each radial for insertion through the connector. Solder the radials to the connector using a large soldering iron or propane torch.

Solder the element to the center pin of the connector. If the element does not fit inside the solder cup, use a short section of brass tubing as a coupler (a slotted $\frac{1}{8}$ inch ID tube will fit over an SO-239 or N receptacle center pin).

If necessary, prune the antenna to raise the frequency of minimum SWR. Then adjust the radial droop angle for minimum SWR — this should not affect the frequency at which the minimum SWR occurs.

One mounting method for fixed-station antennas appears in Figure 21.86. The feed line and connector are inside the mast, and a hose clamp squeezes the slotted mast end to tightly grip the plug body. Once the antenna is mounted and tested, thoroughly seal the open side of the coaxial connector with silicone sealant and weatherproof the connections with rust-preventative paint.

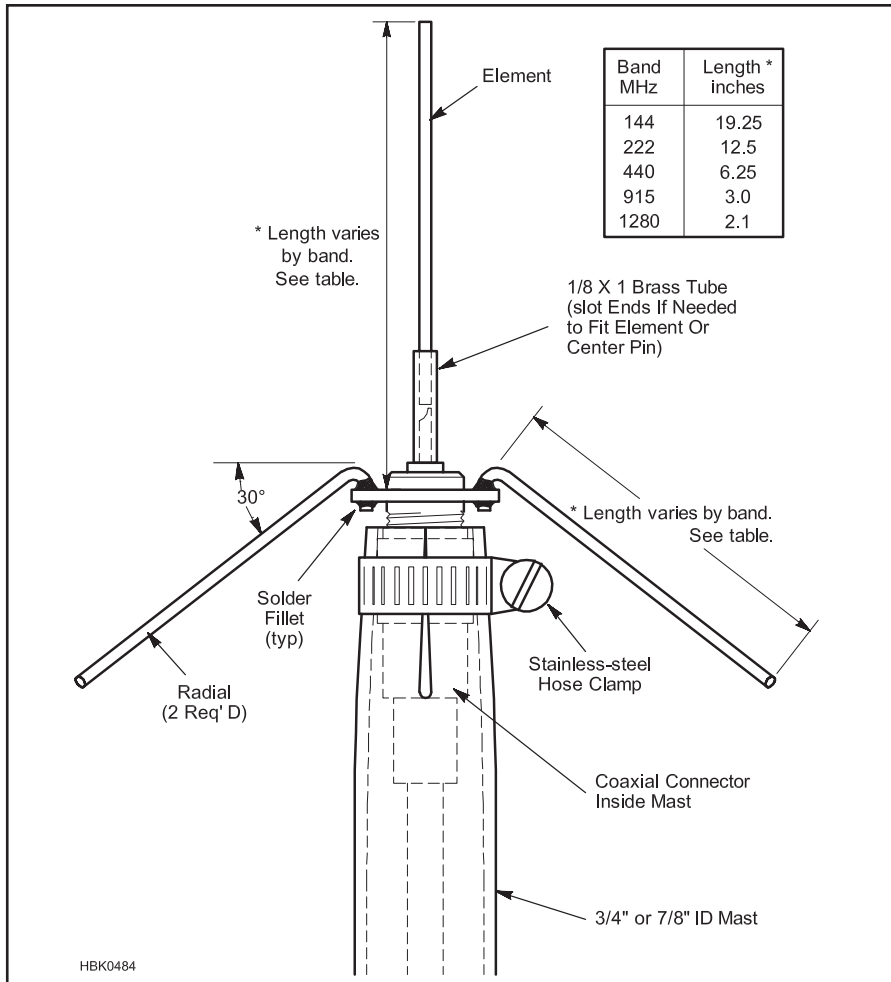

Figure 21.86 — A simple ground-plane antenna for the 144, 222 or 440 MHz bands. The feed line and connector are inside the mast, and a hose clamp squeezes the slotted mast end to tightly grip the plug body. Element and radial dimensions given in the drawing are good for the entire band.

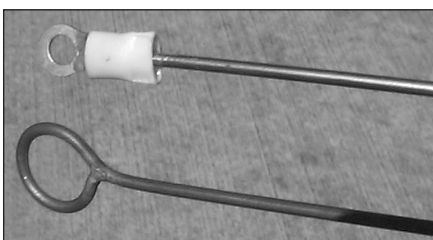

Figure 21.87 — Alternate methods for terminating element and radial tips on the simple ground-plane antenna. See text. (Photo by K8CH)

A related simple antenna is the crossed-dipole, which has an omnidirectional pattern and requires no ground plane. Paul Wade, W1GHZ, rescaled a design found in an IEEE journal that was originally designed for 1.7 GHz. His construction article from the *Proceedings of Microwave Update 2016* is included with the online information for this book.

Project: Coaxial Dipole for VHF or UHF

(The following antenna was originally described in July 2009 *QST* by John Portune, W6NBC, and was also reprinted in *The ARRL Antenna Compendium Volume 8*.)

Here is a homebrew coaxial dipole built from a small stainless whip, a length of threaded table-lamp tubing, and some 3/4 inch copper and PVC fittings. The one shown is for 440 MHz, but it can readily be scaled for 146 or 222 MHz.

For homebrew vertical VHF antennas, coaxial dipoles often play second fiddle to J-poles. That's because the center connection to coax is often difficult to fabricate in the home workshop. Yet both antennas have the same performance. They're both full sized, half wave vertical dipoles, and the coaxial is shorter.

MAKING A COAXIAL DIPOLE

If you start with a common half wave ($\lambda/2$) stainless whip and extend it all the way down

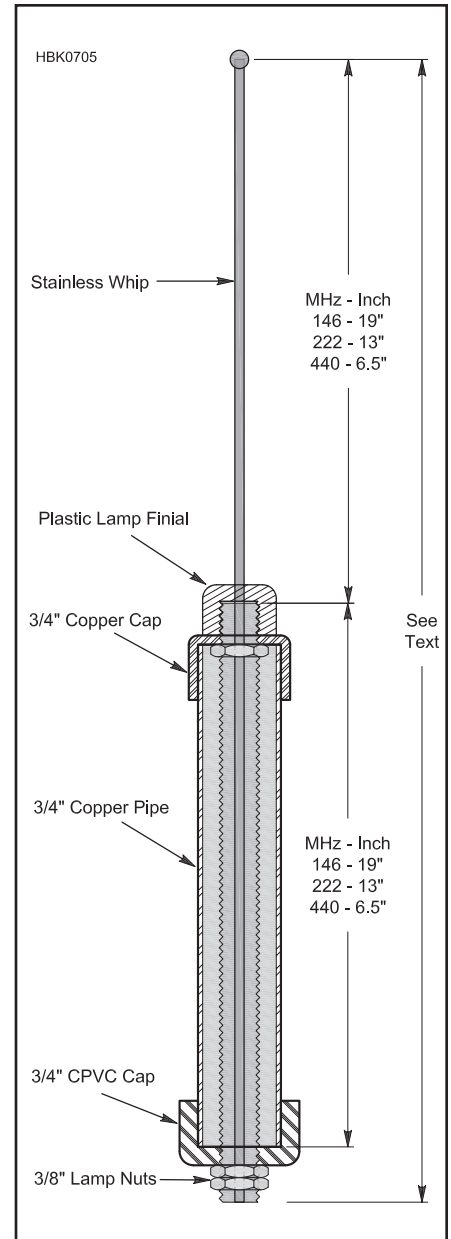
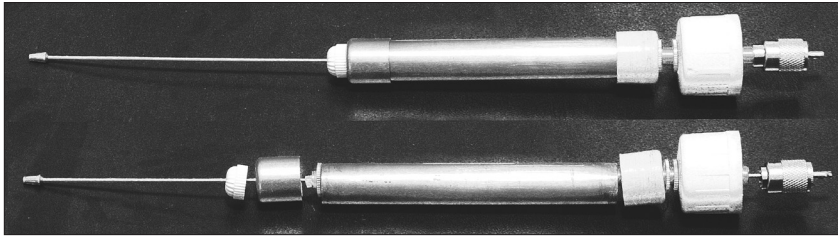

Figure 21.88 — Dimensioned drawing of coaxial dipole for three bands.

through a $\lambda/2$ long support tubing, here made from a threaded table lamp tube, the lower part of the whip becomes the center conductor of a short length of rigid coax feeding the center of the antenna. Now connection to normal coax is easily made below the antenna. To form the rigid coax section, you'll need to insulate the center conductor (lower part of the stainless whip) from the lamp tubing with some 1/4 inch inside diameter (ID) polyethylene tubing. Hardware stores normally carry it. This short length of rigid coax formed in this way isn't precisely 50 Ω characteristic impedance, but the difference is totally insignificant. The drawing in **Figure 21.88** shows the details.



(A)

Figure 21.89 — Details of final assembly of coaxial dipole (A) and the finished product (B).

Assembly Details

The bottom half ($\lambda/4$) of the radiating dipole is a coaxial sleeve made from $\frac{3}{4}$ inch copper pipe and a pipe cap. The coax feed runs up its center to the connector at the bottom of the lamp tubing. Support and insulation of the bottom of the sleeve is provided by a $\frac{3}{4}$ inch CPVC plastic pipe cap. For those not familiar with CPVC fittings, they're made to mate with copper pipe and can handle high water temperatures. That's not true of common PVC fittings. Most hardware stores now carry CPVC. Drill a $\frac{3}{8}$ inch hole in the center top of the copper and the CPVC caps for the lamp tubing to pass through.

The whole antenna is held together by two lamp tubing nuts and a plastic lamp finial, also readily available at hardware stores (see **Figure 21.89**). Note that a lamp tubing nut is also required inside the copper pipe cap. Drill a small hole in the middle of the lamp finial for the stainless whip. On the bottom of lamp tubing below the antenna install a $\frac{1}{4}$ inch common PVC pipe cap and secure it with two more lamp tubing nuts. This gives you a way to easily mount the antenna on top of any convenient length of $\frac{1}{4}$ inch PVC pipe. Run the coax feed down through the PVC pipe. (Note that lamp parts are generally not intended for use outside and may rust or corrode without being painted or otherwise protected against the weather.)

Hooking it Up

A conventional PL-259 UHF type coax connector for RG-8 coax will actually screw onto the bottom of the lamp tubing. The threads are

not a perfect fit, but will tighten satisfactorily. The stainless whip runs down all the way to the very tip of the PL-259 connector. Solder it in there. Before doing so, however, install all the pieces of the antenna onto the threaded lamp tubing.

Many hams may think that stainless steel won't solder. It definitely will with a hot iron and acid flux. Scrape the end of the whip and dip it in hydrochloric swimming pool acid. With a little action from the tip of the soldering iron the whip will tin perfectly well. Before soldering, however, grind two or three small side notches in the bottom end of the whip. A Dremel tool works well for this. The notches will help the solder securely lock the whip into the tip of the PL-259 connector. Neutralize any leftover acid with baking soda solution.

Perhaps surprising to some, it really isn't necessary to solder any other parts of the antenna. There is adequate mating surface at the joints for the RF to cross over efficiently. Do, however, seal all possible water access spots with common silicone sealant and/or plastic electrical tape.

MAKE IT FOR THE BAND YOU LIKE

There isn't an exact length required for the lamp tubing or the stainless whip. These merely need to provide enough space for all the pieces of the antenna to go together. The author had a 48 inch whip on hand that he used uncut for the 146 MHz coaxial dipole and a similar 17 inch uncut whip for 440 MHz. He cut the lamp tubing to an appropriate length to fit the whips. What does matter, however, is the length of the whip above the top of the lamp tubing as well as

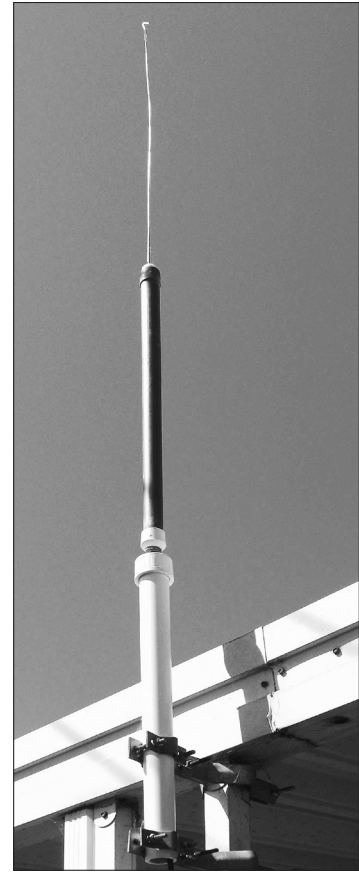

(B)

the length of the coaxial sleeve. These need to be close to a $\lambda/4$ — for 440 MHz, $6\frac{1}{2}$ inches; for 222 MHz, 13 inches; and 19 inches for 146 MHz. These antennas are quite broadband and will cover the entire band in each case with these sizes. No cutting or pruning is necessary.

For ruggedness, or perhaps for stealth, you can install the whole antenna inside of 2 inch PVC water or ABS soil pipe and close the ends with end caps. The author lives in a mobile home park where antennas are not permitted, but these coaxial dipoles (in ABS pipe) look like vent pipes.

Try out one of these homebrew coaxial dipoles. You may find you prefer its smaller size, less obvious appearance, and superior weatherproofing as compared to a J-pole.

21.11 VHF/UHF Beams

Without doubt, the Yagi is king of home-station antennas these days. Today's best designs are computer optimized. For years amateurs as well as professionals designed Yagi arrays experimentally. Now we have powerful (and inexpensive) personal computers and sophisticated software for antenna modeling. These have brought us antennas with improved performance, with little or no element pruning required. A more complete discussion of Yagi design can be found earlier in this chapter and in the *ARRL Antenna Book*.

21.11.1 Stacking Yagis

Where suitable provision can be made for supporting them, two Yagis mounted one above the other and fed in-phase may be preferable to one long Yagi having the same theoretical or measured gain. The pair will require a much smaller turning space for the same gain, and their lower radiation angle can provide interesting results. On long ionospheric paths a stacked pair occasionally may show an apparent gain much greater than the 2 to 3 dB that can be measured locally as the gain from stacking.

Optimum spacing for Yagis with booms

longer than 1λ is one wavelength, but this may be too much to handle for many builders of 50 MHz antennas. Worthwhile results are possible with separations of as little as $\frac{1}{2} \lambda$ (10 feet), but $\frac{5}{8} \lambda$ (12 feet) is markedly better. At 50 MHz, the difference between 12 and 20 foot spacing may not be worth the added structural problems.

The closer spacings give lowered measured gain, but the antenna patterns are cleaner (less power in the high-angle elevation lobes) than with 1λ spacing. Extra gain with wider spacings is usually the objective on 144 MHz and higher bands, where the structural problems are not quite as severe as on 50 MHz.

One method for feeding two 50 Ω antennas, as might be used in a stacked Yagi array, is shown in **Figure 21.90**. The transmission lines from each antenna, with a balun feeding each one (not shown in the drawing for simplicity), to the common feed point must be equal in length and an odd multiple of $\frac{1}{4} \lambda$. This line acts as a quarter-wave (Q-section) impedance transformer, raises the feed impedance of each antenna to 100 Ω , and forces current to be equal in each driven element. When the feed lines are connected in parallel at the coaxial tee connector, the resulting impedance is close to 50 Ω .

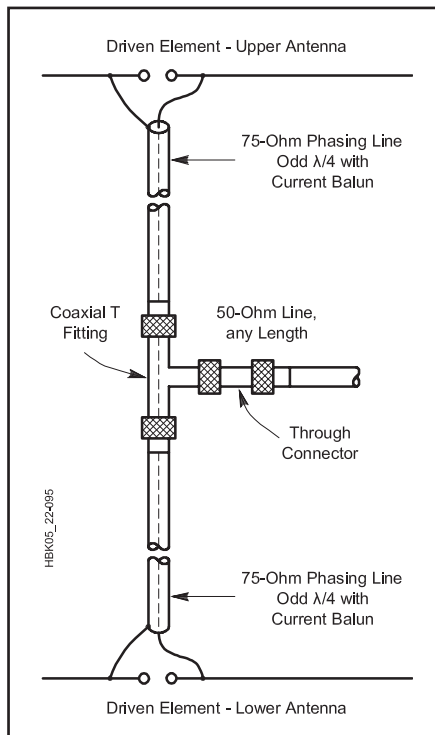

Figure 21.90 — A method for feeding a stacked Yagi array. Note that baluns at each antenna are not specifically shown. Good practice is to use choke baluns made up of ferrite beads slipped over the outside of the coax and taped to prevent movement. See the *RF Techniques and Transmission Lines* chapters for details.

Project: Three and Five-Element Yagis for 6 Meters

Boom length often proves to be the deciding factor when one selects a Yagi design. Dean Straw, N6BV, created the designs shown in **Table 21.14**. Straw generated the designs in the table for convenient boom lengths (6 and 12 feet). The 3 element design has about 8 dBi gain, and the 5 element version has about 10 dBi gain. Both antennas exhibit better than 22 dB front-to-rear ratio, and both cover 50 to

51 MHz with better than 1.6:1 SWR.

Element lengths and spacings are given in the table. Elements can be mounted to the boom as shown in **Figure 21.91**. Two muffler clamps hold each aluminum plate to the boom, and two U bolts fasten each element to the plate, which is 0.25 inches thick and 4.4 inches square. Stainless steel is the best choice for hardware. However, galvanized hardware can be substituted. Automotive muffler clamps do not work well in this application, because they are not galvanized and quickly rust once exposed to the weather.

The driven element is mounted to the boom on a phenolic plate of similar dimension to the other mounting plates. A 12 inch piece of Plexiglas rod is inserted into the driven element halves. The Plexiglas allows the use of a single clamp on each side of the element and also seals the center of the elements against moisture. Self-tapping screws are used for electrical connection to the driven element.

Refer to **Figure 21.92** for driven element

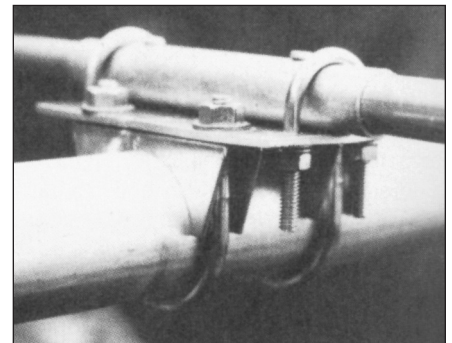

Figure 21.91 — The boom-to-element clamp. Galvanized U-bolts are used to hold the element to the plate, and 2 inch galvanized muffler clamps hold the plates to the boom.

Table 21.14

Optimized 6 Meter Yagi Designs

	Spacing From Reflector (in.)	Seg 1 Length (in.)	Seg 2 Length (in.)	Midband Gain F/R
306-06				
Refl	0	36	23.500	8.1 dBi
DE	24	36	16.000	28.3 dB
Dir 1	66	36	15.500	
506-12				
OD		0.750	0.625	
Refl	0	36	23.625	10.0 dBi
DE	24	36	17.125	26.8 dB
Dir 1	36	36	19.375	
Dir 2	80	36	18.250	
Dir 3	138	36	15.375	

Note: For all antennas, telescoping tube diameters (in inches) are: Seg1=0.750, Seg2=0.625.

Boom length should be 6 inches longer than the maximum Refl-Dir spacing to allow 3 inches on each end for element mounting hardware.

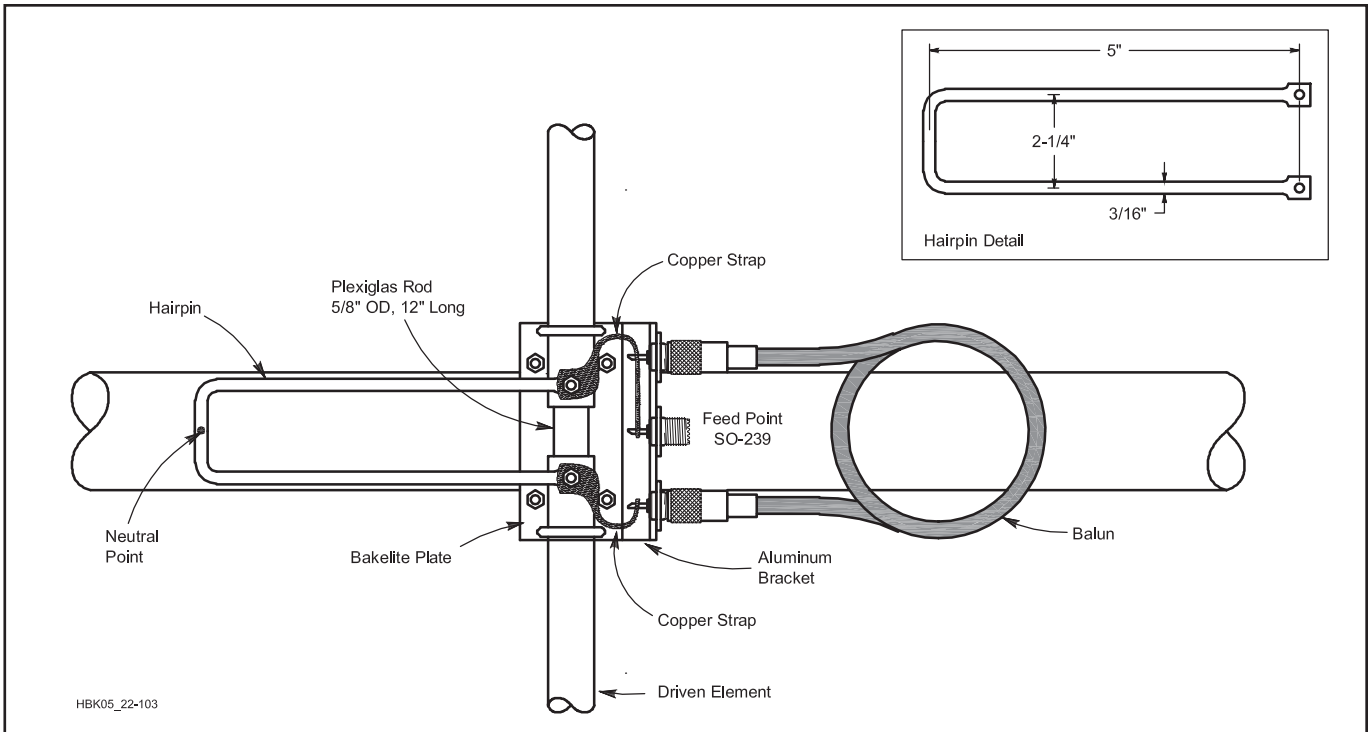

Figure 21.92 — Detailed drawing of the feed system used with the 50 MHz Yagi. Balun lengths: For cable with 0.80 velocity factor — 7 feet, 10³/₁₆ inches. For cable with 0.66 velocity factor — 6 feet, 5³/₄ inches.

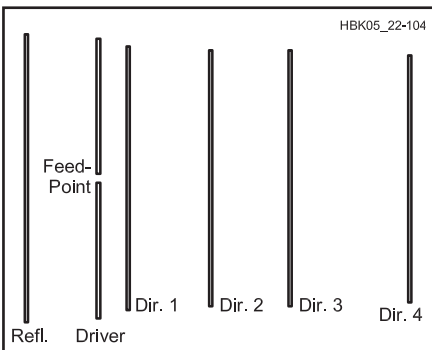

Figure 21.93 — The general outline of the 2 meter, 6 element OWA Yagi. Dimensions are given in Table 21.15.

and hairpin match details. A bracket made from a piece of aluminum is used to mount the three SO-239 connectors to the driven element plate. A 4:1 transmission-line balun connects the two element halves, transforming the 200 Ω resistance at the hairpin match to 50 Ω at the center connector. Note that the electrical length of the balun is $\lambda/2$, but the physical length will be shorter due to the velocity factor of the particular coaxial cable used. The hairpin is connected directly across the element halves. The exact center of the hairpin is electrically neutral and should be fastened to the boom. This has the advantage of placing the driven element at dc ground potential.

The hairpin match requires no adjustment as such. However, you may have to change

the length of the driven element slightly to obtain the best match in your preferred portion of the band. Changing the driven-element length will not adversely affect antenna performance. *Do not adjust the lengths or spacings of the other elements — they are optimized already.* If you decide to use a gamma match, add three inches to each side of the driven element lengths given in the table for both antennas.

Project: Medium-Gain 2 Meter Yagi

This project was designed and built by L. B. Cebik, W4RNL (SK). Practical Yagis for 2 meters abound. What makes this one a bit different is the selection of materials. The elements, of course, are high-grade aluminum. However, the boom is PVC, and there are only two #6 nut-bolt sets and two #8 sheet metal screws in the entire antenna. The remaining fasteners are all hitch-pin clips. The result is a very durable six-element Yagi that you can disassemble with fair ease for transport. The complete construction details and more discussion of the antenna are included with the online content.

THE BASIC ANTENNA DESIGN

The 6 element Yagi presented here is a derivative of the *optimized wide-band antenna* (OWA) designs developed for HF use by NW3Z and WA3FET. **Figure 21.93** shows the

general outline. The reflector and first director largely set the impedance. The next 2 directors contribute to setting the operating bandwidth. The final director (Dir. 4) sets the gain. This account is oversimplified, since every element plays a role in every facet of Yagi performance. However, the notes give some idea of which elements are most sensitive in adjusting the performance figures.

Designed using *NEC-4*, the antenna uses 6 elements on a 56 inch boom. **Table 21.15** gives the specific dimensions for the version described in these notes. The parasitic elements are all ³/₁₆ inch aluminum rods. For ease of construction, the driver is ¹/₂ inch aluminum tubing. Do not alter the element diameters without referring to a source, such as RSGB's *The VHF/UHF DX Book*, edited by Ian White, G3SEK, (chapter 7), for information on how to recalculate element lengths.

The OWA design provides about 10.2 dBi of free-space gain with better than 20 dB front-to-back (or front-to-rear) ratio across the entire 2 meter band. Azimuth (or E-plane) patterns show solid performance across the entire band. This applies not only to forward gain but rejection from the rear.

One significant feature of the OWA design is its direct 50 Ω feed point impedance, which requires no matching network. Of course, a choke balun to suppress any currents on the feed line is desirable, and a simple ferrite bead balun (see the **Transmission Lines** chapter) works well in this application. The SWR,

Table 21.15**2 Meter OWA Yagi Dimensions**

Element	Element Length (in)	Spacing from Reflector (in)	Element Diameter (in)
Version described in the text:			
Refl.	40.52	—	0.1875
Driver	39.70	10.13	0.5
Alt. Driver	39.96	10.13	0.1875
Dir. 1	37.36	14.32	0.1875
Dir. 2	36.32	25.93	0.1875
Dir. 3	36.32	37.28	0.1875
Dir. 4	34.96	54.22	0.1875
Version using 1/8-inch diameter elements throughout:			
Refl.	40.80	—	0.125
Driver	40.10	10.20	0.125
Dir. 1	37.63	14.27	0.125
Dir. 2	36.56	25.95	0.125
Dir. 3	36.56	37.39	0.125
Dir. 4	35.20	54.44	0.125

shown in **Figure 21.94**, is very flat across the band and never reaches 1.3:1. The SWR and the pattern consistency together create a very useful utility antenna for 2 meters, whether installed vertically or horizontally. The only remaining question is how to effectively build the beam in the average home shop.

The six-element OWA Yagi for 2 meters performs well. It serves as a good utility antenna with more gain and directivity than the usual three-element general-use Yagi. When vertically polarized, the added gain confirms the wisdom of using a longer boom and more elements. With a length under five feet, the antenna is still compact. The ability to disassemble the parts simplifies moving the antenna to various portable sites.

Project: Utility Yagi for 432 MHz

The following design was developed by Zack Lau, W1VT (see References), and is included in the online information for this chapter. This six-element Yagi has a wide bandwidth for gain, F/B ratio, and SWR, covering almost all of the 70 cm band. The short 30-inch boom is small enough to fit in the trunk of a compact sedan, perfect for portable or emergency operation. The optimized design is shown in **Figure 21.95**, which includes the table of element lengths and placement. Changing the boom or element mounting may require adjusting the element lengths. The antenna uses a simple T-match to preserve a symmetrical radiation pattern.

Project: Cheap Yagis by WA5VJB

If you're planning to build an EME array, don't use these antennas. But if you want to put together a VHF rover station with less than \$500 in the antennas, read on as Kent Britain, WA5VJB, shows you how to put together a

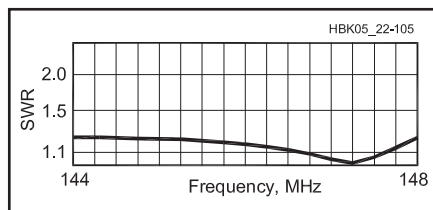

Figure 21.94 — SWR curve for the 2 meter, 6 element OWA Yagi as modeled using NEC-4.

VHF/UHF Yagi with QRO performance at a QRP price. (This material is adapted from Kent's on-line paper "Controlled Impedance 'Cheap' Antennas" at www.wa5vjb.com/references.html.) First, a bit of history on the design of these antennas. In 1993 at the Oklahoma City Central States VHF Society Conference, Arnie, CO2KK, spoke on the difficulties building VHF antennas in non-industrialized nations. Just run down to the store and pick up some Delrin insulators and 0.141 inch Teflon coax? Arnie's tales were the motivation to use advanced technology to come up with something simple.

The simplified feed uses the structure of the antenna itself for impedance matching. So the design started with the feed and the elements were built around it. The antennas were designed with *YagiMax*, tweaked in *NEC*, and the driven elements experimentally determined on the antenna range.

Typically a high-gain antenna is designed in the computer, then you try to come up with a driven element matching arrangement for whatever feed point impedance the computer comes up with. In this design, compromises for the feed impedance, asymmetrical feed, simple measurements, wide bandwidth, the ability to grow with the same spacing, and trade-offs for

a very clean pattern cost many dB of gain. But you can build these antennas for about \$5!

Construction of the antennas is straightforward. The boom is 3/4 inch square, or 1/2 inch by 3/4 inch wood. To install an element, drill a hole through the boom and insert the element. A drop of cyanoacrylate "super glue," epoxy, or silicone adhesive is used to hold the elements in place. There is no boom-to-mast plate — drill holes in the boom and use a U-bolt to attach it to the mast!

The life of the antenna is determined by what you coat it with. The author had a 902 MHz version, varnished with polyurethane, in the air for two years with little deterioration.

The parasitic elements on prototypes have been made from silicon-bronze welding rod, aluminum rod, brass hobby tubing, and #10 or #12 AWG solid copper ground wire. So that you can solder to the driven element, use the welding rod, hobby tubing, or copper wire. The driven element is folded at one end with its ends inserted through the boom.

Figure 21.96 shows the basic plan for the antenna and labels the dimensions that are given in the table for each band. All table dimensions are given in inches.

Figure 21.97 shows how the driven element is constructed for each antenna. Trim the free end of the driven element to tune it for minimum SWR at the desired frequency. **Figure 21.98** shows how to attach coaxial cable to the feed point. Sliding a quarter-wave sleeve along the coax had little effect, so there's not much RF on the outside of the coax. You may use a ferrite bead choke balun if you like, but these antennas are designed for minimum expense!

144 MHz Yagi

While others have reported good luck with 16 element long-boom wood antennas, six elements was about the maximum for most rovers. The design is peaked at 144.2 MHz, but performance is still good at 146.5 MHz. All parasitic elements are made from 3/16 inch aluminum rod, and the driven element is made from 1/8 inch rod. Lengths and spacings are given in **Table 21.16**.

222 MHz Yagi

This antenna is peaked at 222.1 MHz, but performance has barely changed at 223.5 MHz. You can drill the mounting holes to mount it with the elements horizontal or vertical. All parasitic elements are made from 3/16 inch aluminum rod, and the driven element is made from 1/8 inch rod. Lengths and spacings are given in **Table 21.17**.

432 MHz Yagi

At this band the antenna is getting very practical and easy to build. All parasitic elements

ANT1131

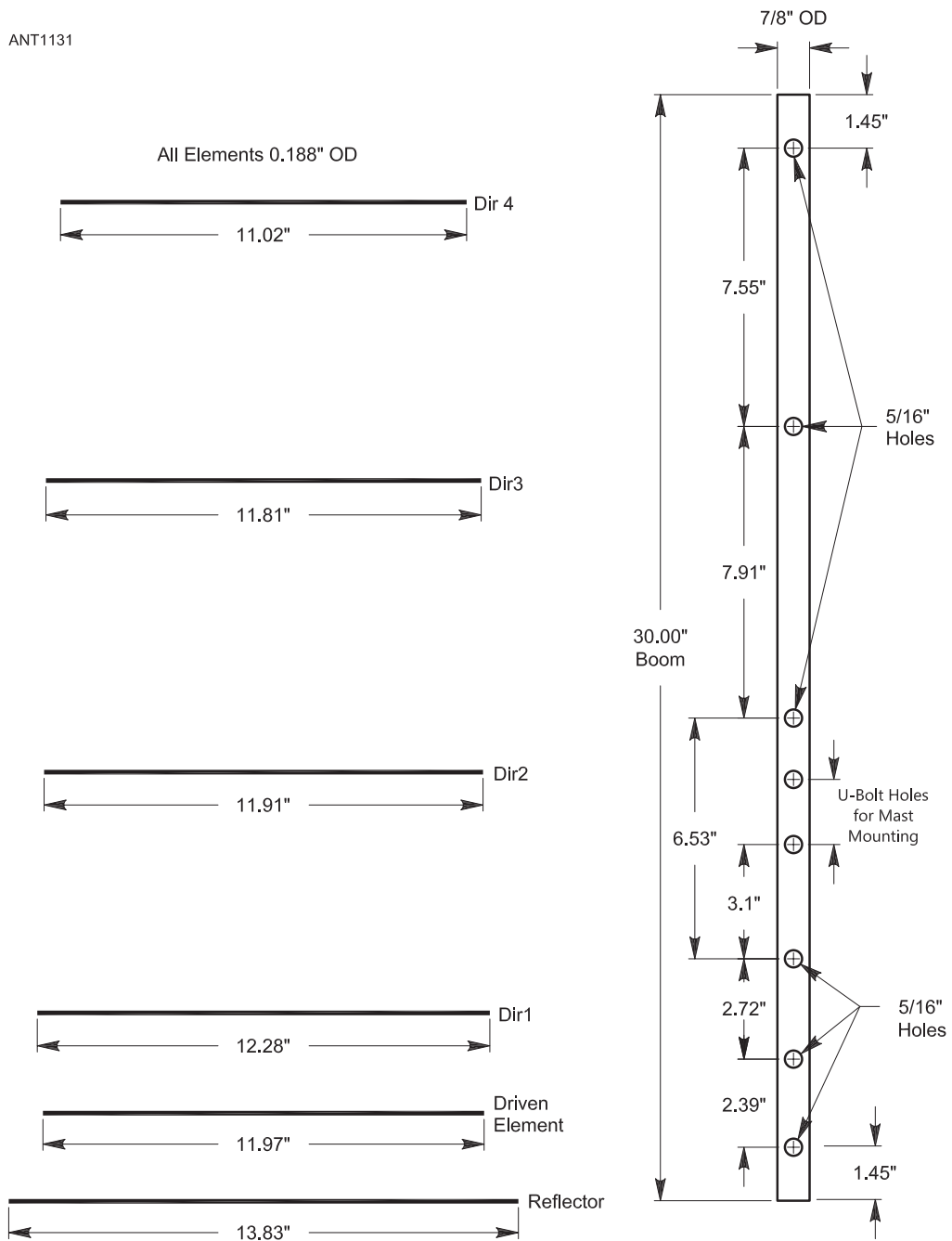

Figure 21.95 — Assembly and design information for the 70 cm Yagi boom and elements.

432-MHz Yagi Dimensions

	<i>Spacing Between Elems. (inches)</i>	<i>Spacing from Reflector (inches)</i>	<i>Full Element Length (inches)</i>
Reflector	0	—	13.832
Driven Ele.	2.394	2.394	11.968
Dir. 1	2.715	5.109	12.284
Dir. 2	6.528	11.637	11.908
Dir. 3	7.907	19.544	11.810
Dir. 4	7.546	27.09	11.01

are made from 1/8 inch diameter rod, and the driven element is made from #10 AWG solid copper wire. Lengths and spacings are given in **Table 21.18**.

435 MHz Yagi for AMSAT

KA9LNV provided help and motivation for these antennas. A high front-to-back ratio (F/B) was a major design consideration of all versions. The model predicts 30 dB F/B for the 6-element and over 40 dB for the others. For gain, NEC predicts 11.2 dBi for the six-element, 12.6 dBi for the eight-element, 13.5 dBi for the 10 element, and 13.8 dBi for the 11 element.

Using 3/4 inch square wood for the boom makes it easy to build two antennas on the same boom for cross-polarization. Offset the two antennas 6 1/2 inches along the boom and feed them in-phase for circular polarization, or just use one for portable operations. All parasitic elements are made from 1/8 inch diameter rod, and the driven element is made from #10 AWG solid copper wire. Lengths and spacings are given in **Table 21.19**. The same element spacing is used for all four versions of the antenna.

450 MHz Yagi

For FM, this six-element Yagi is a good, cheap antenna to get a newcomer into a repeater or make a simplex-FM QSO during a

contest. The author used 1/8 inch diameter aluminum ground wire in the prototype for all the elements except the driven element, which is made from #10 AWG solid copper wire. Other 1/8 inch diameter material could be used. Lengths and spacings are given in **Table 21.20**.

902 MHz Yagi

This was the first antenna the author built using the antenna to control the driven element impedance. The 2.5 foot length has proven very practical. All parasitic elements are made from 1/8 inch diameter rod, and the driven ele-

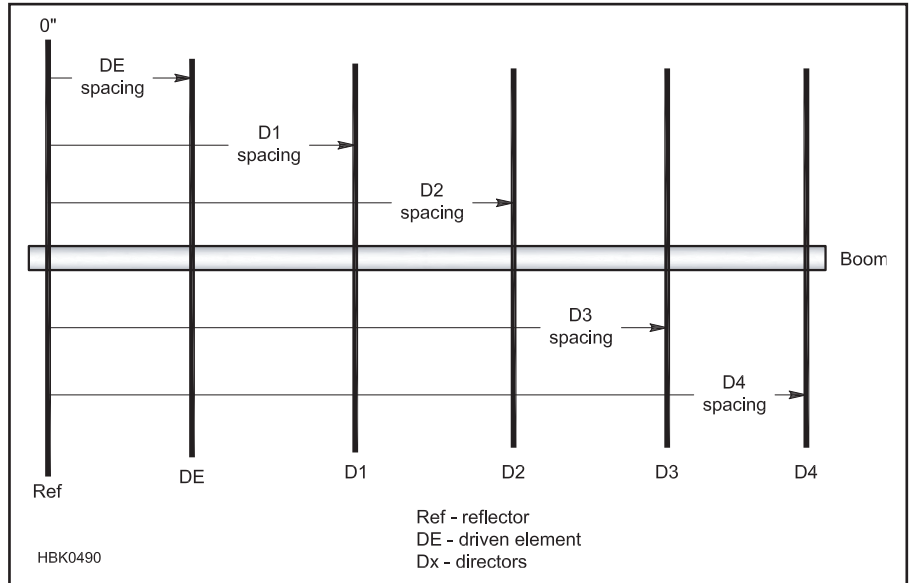

Figure 21.96 — Element spacing for the Cheap Yagis. Refer to Tables 21.16 to 21.23 for exact dimensions for the various bands.

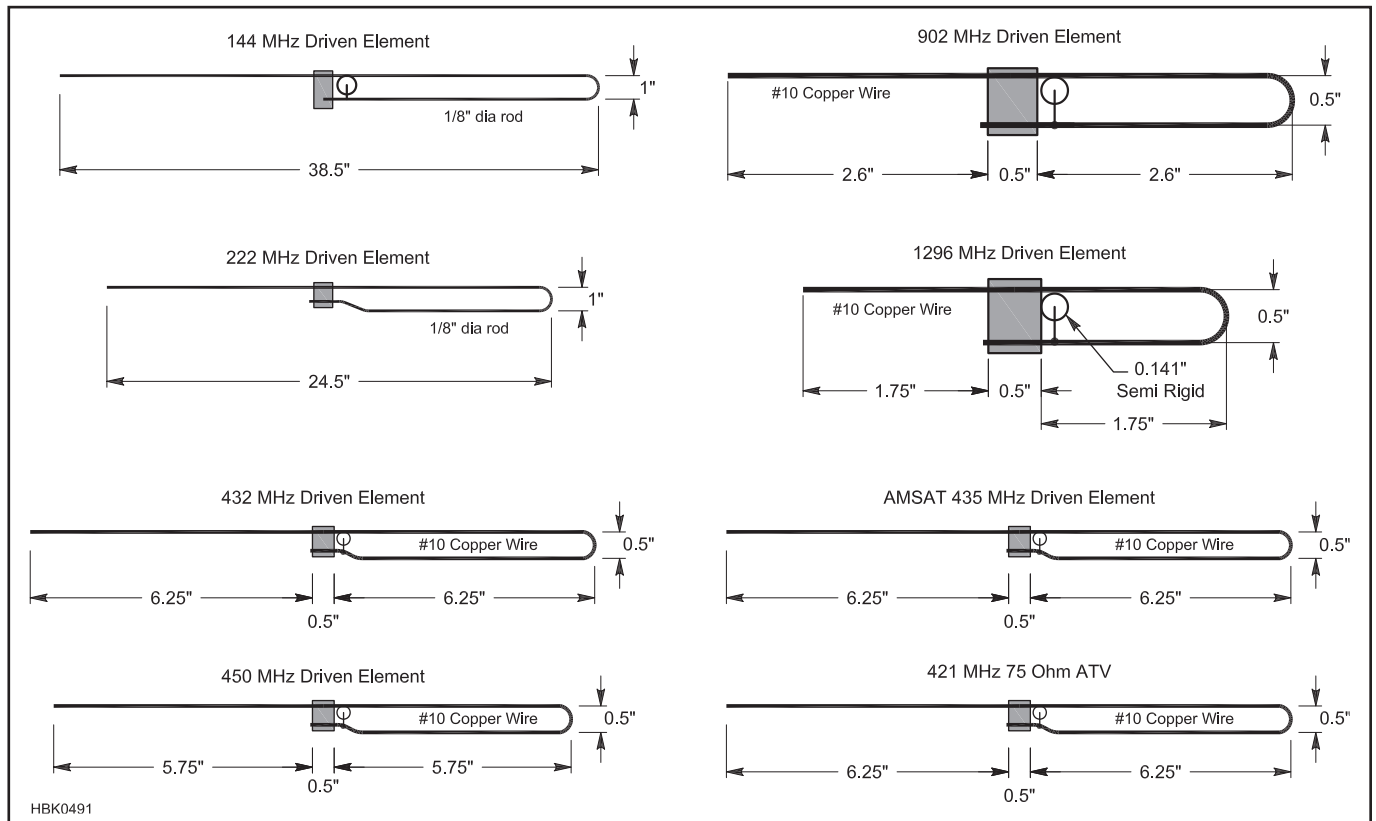

Figure 21.97 — Driven element dimensions for the Cheap Yagis. Attaching the coax shield to the center of the driven element is appropriate because that is the lowest impedance point of the element.

ment is made from #10 AWG solid copper wire. Lengths and spacings are given in **Table 21.21**.

1296 MHz Yagi

This antenna is the veteran of several “Grid-peditions” and has measured 13.5 dBi on the Central States VHF Society antenna range. Dimensions must be followed with great care. The driven element is small enough to allow 0.141 inch semi-rigid coax to be used. The prototype antennas use 1/8 inch silicon-bronze welding rod for the elements, but any 1/8 inch-diameter material can be used. The driven element is made from #10 AWG solid copper wire. Lengths and spacings are given in **Table 21.22**.

421.25 MHz 75 Ω Yagi for ATV

421 MHz vestigial sideband video is popular in North Texas for receiving the FM video input repeaters. These antennas are made for 421 MHz use, and the driven element is designed for 75 Ω. RG-59, or an F adapter to RG-6 can be directly connected to a cable-TV converter or cable-ready TV on channel 57. All parasitic elements are made from 1/8 inch diameter rod, and the driven element is made from #10 AWG solid copper wire. Lengths and spacings are given in **Table 21.23**. The same spacing is used for all versions.

Project: Fixed Moxons for Satellite Operation

The following project is based on the article “A Simple Fixed Antenna for VHF/UHF Satellite Work” by the late L.B. Cebik, W4RNL, from the August 2001 issue of *QST*. The complete article is available with the online content. This design produces a simple, reliable, fixed antenna that provides nearly hemispherical coverage for satellite operation on 145 and 435 MHz.

Many fixed-position satellite antennas for VHF and UHF have used a version of the *turnstile*. The word “turnstile” actually refers to two different ideas. One is a particular antenna: two crossed dipoles fed 90° out of phase, usually with a reflecting screen behind the dipoles. The other is the principle of obtaining omnidirectional patterns by diving almost any crossed antennas 90° out of phase. The second

Table 21.16

WA5VJB 144 MHz Yagi Dimensions

		Ref	DE	D1	D2	D3	D4
3-element	Length	41.0	—	37.0			
	Spacing	0	8.5	20.0			
4-element	Length	41.0	—	37.5	33.0		
	Spacing	0	8.5	19.25	40.5		
6-element	Length	40.5	—	37.5	36.5	36.5	32.75
	Spacing	0	7.5	16.5	34.0	52.0	70.0

Dimensions in inches.

Table 21.17

WA5VJB 222 MHz Yagi Dimensions

		Ref	DE	D1	D2	D3	D4
3-element	Length	26.0	—	23.75			
	Spacing	0	5.5	13.5			
4-element	Length	26.25	—	24.1	22.0		
	Spacing	0	5.0	11.75	23.5		
6-element	Length	26.25	—	24.1	23.5	23.5	21.0
	Spacing	0	5.0	10.75	22.0	33.75	45.5

Table 21.18

WA5VJB 432 MHz Yagi Dimensions

		Ref	DE	D1	D2	D3	D4	D5	D6	D7	D8	D9
6-element	Length	13.5	—	12.5	12.0	12.0	11.0					
	Spacing	0	2.5	5.5	11.25	17.5	24.0					
8-element	Length	13.5	—	12.5	12.0	12.0	12.0	12.0	11.25			
	Spacing	0	2.5	5.5	11.25	17.5	24.0	30.75	38.0			
11-element	Length	13.5	—	12.5	12.0	12.0	12.0	12.0	12.0	11.75	11.75	11.0
	Spacing	0	2.5	5.5	11.25	17.5	24.0	30.75	38.0	45.5	53.0	59.5

Dimensions in inches.

Table 21.19

WA5VJB 435 MHz Yagi Dimensions

		Ref	DE	D1	D2	D3	D4	D5	D6	D7	D8	D9
6-element	Length	13.4	—	12.4	12.0	12.0	11.0					
8-element	Length	13.4	—	12.4	12.0	12.0	12.0	12.0	11.1			
10-element	Length	13.4	—	12.4	12.0	12.0	12.0	12.0	11.75	11.75	11.1	
11-element	Length	13.4	—	12.4	12.0	12.0	12.0	12.0	11.75	11.75	11.75	11.1
	Spacing	0	2.5	5.5	11.25	17.5	24.0	30.5	37.75	45.0	52.0	59.5

Dimensions in inches.

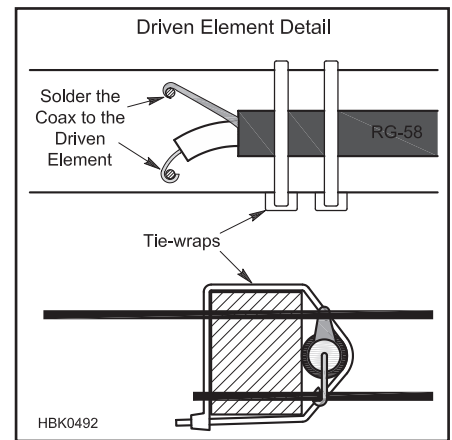

Figure 21.98 — Construction details and feed line attachment for the Cheap Yagi driven element.

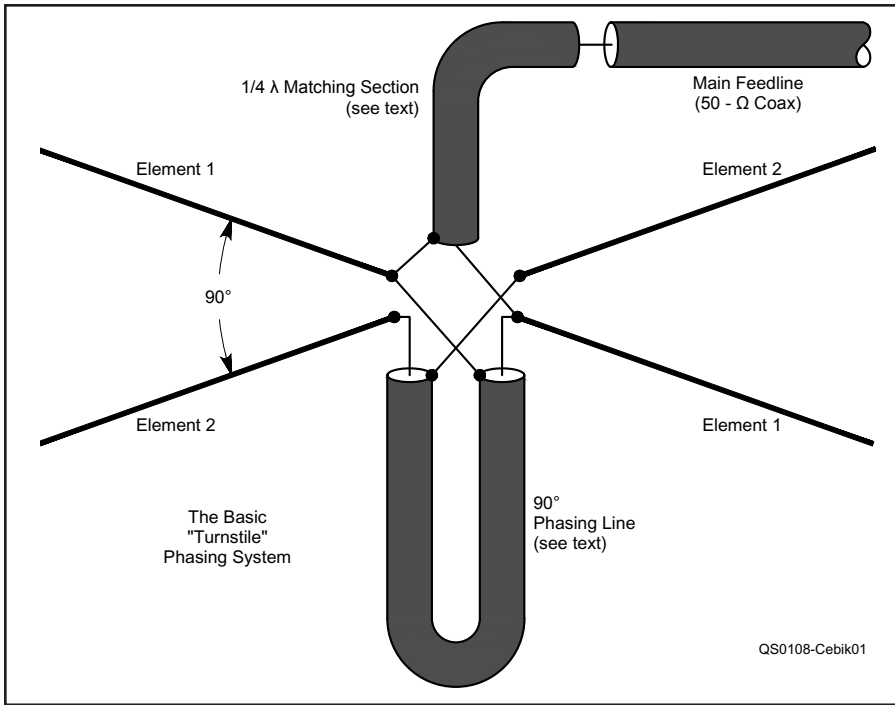

Figure 21.99 — The basic turnstile phasing (and matching) system for any antenna set requiring a 90° phase shift between driven elements in proximity.

idea opens the door to adapting many possible antenna designs to omnidirectional coverage.

Figure 21.99 shows a general method of obtaining the 90° phase shift for omnidirectional patterns. Note that the coax center conductor connects to only one of the two crossed elements. A $\frac{1}{4}\lambda$ section of transmission line that has the same characteristic impedance as the natural feed point impedance of the first antenna element alone connects one element to the next. The opposing ends of the two elements go to the shield at each end of the transmission line. The resulting impedance at the overall antenna feed point will be exactly half the impedance of one element alone. If dipoles are used, the feed point impedance will be approximately 35 Ω.

The dual Moxon rectangle array, shown in outline form on the right of **Figure 21.100**, offers some advantages over the traditional turnstile. (The article “Having a Field Day with the Moxon Rectangle,” by L.B. Cebik describes the Moxon in detail and is included with the online content.) First, it yields a somewhat better dome-like pattern. Second, it is relatively easy to build and compact to install. The Moxon pair, with lower but smoother gain across the dome of the sky, offers the fixed-antenna user the chance to build a successful beginning satellite antenna.

Figure 21.101 shows the elevation patterns of a turnstile-and-screen and of a pair of Moxon rectangles when both are 2λ above the ground. A 1λ height will reduce the low angle ripples even more, if that height is feasible. The elevation patterns show the considerably smoother

Table 21.20

WA5VJB 450 MHz Yagi Dimensions

		Ref	DE	D1	D2	D3	D4
6-element	Length	13.0	—	12.1	11.75	11.75	10.75
	Spacing	0	2.5	5.5	11.0	18.0	28.5

Dimensions in inches.

Table 21.21

WA5VJB 902 MHz Yagi Dimensions

		Ref	DE	D1	D2	D3	D4	D5	D6	D7	D8
10-element	Length	6.2	—	5.6	5.5	5.5	5.4	5.3	5.2	5.1	5.1
	Spacing	0	2.4	3.9	5.8	9.0	12.4	17.4	22.4	27.6	33.0

Dimensions in inches.

Table 21.22

WA5VJB 1296 MHz Yagi Dimensions

		Ref	DE	D1	D2	D3	D4	D5	D6	D7	D8
10-element	Length	4.3	—	3.9	3.8	3.75	3.75	3.65	3.6	3.6	3.5
	Spacing	0	1.7	2.8	4.0	6.3	8.7	12.2	15.6	19.3	23.0

Dimensions in inches.

Table 21.23

WA5VJB 421.25 MHz 75-Ω Yagi Dimensions

		Ref	DE	D1	D2	D3	D4	D5	D6	D7	D8	D9
6-element	Length	14.0	—	12.5	12.25	12.25	11.0					
9-element	Length	14.0	—	12.5	12.25	12.25	12.0	12.0	11.25			
11-element	Length	14.0	—	12.5	12.25	12.25	12.0	12.0	12.0	11.75	11.75	11.5
	Spacing	0	3.0	6.5	12.25	17.75	24.5	30.5	36.0	43.0	50.25	57.25

Dimensions in inches.

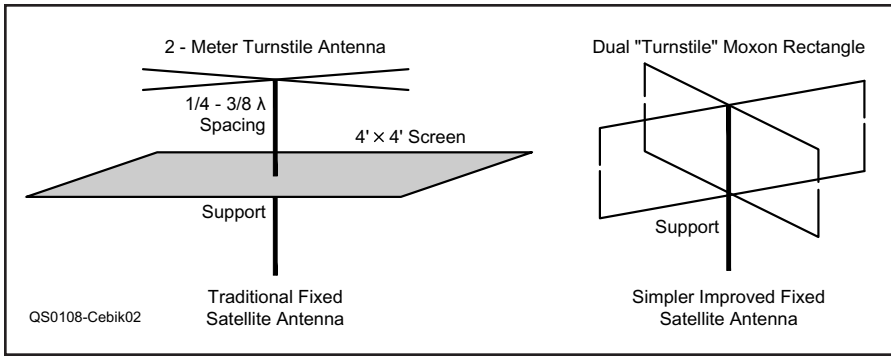

Figure 21.100 — Alternative schemes for fixed-position satellite antennas: the traditional turnstile-and-screen and a pair of “turnstiled” Moxon rectangles.

pattern dome of the Moxon pair over the traditional turnstile. The middle of the turnstile dome has nearly 2 dB less gain than its peaks, while the top valleys are nearly 3 dB lower than the peaks. The peaks and valleys can make the difference between successful communications and broken-up transmissions.

Without requiring a reflecting screen, which would narrow the antenna’s beamwidth, the azimuthal pattern will be circular within under a 0.2-dB difference for 145.5 to 146.5 MHz, and within 0.5 dB for the entire 2 meter band. Since satellite work is concentrated in the 145.8 to 146.0 MHz region, the broadband antenna will prove fairly easy to build with success. A 435.6 MHz version, designed to cover the 435 to 436.2 MHz region of satellite activity, will have an even larger bandwidth.

Like the dipole-based turnstile, the Moxons are fed 90° out of phase with a ¼-λ phasing line of 50-Ω coaxial cable, as shown in Figure 21.99. Since the natural feed point impedance of a single Moxon rectangle of the design used here is 50 Ω, the pair will show a 25-Ω feed-point impedance. Paralleled ¼-λ sections of

70- to 75-Ω coaxial cable, such as RG-59, will transform the low impedance to a good match for the main 50-Ω coaxial feed line.

Figure 21.102 shows the critical dimensions for a Moxon rectangle. The lettered references are keys to the dimensions in **Table 21.24**. The design frequencies for the two satellite antenna pairs are 145.9 MHz and 435.5 MHz, the centers of the satellite activity on these two bands. The 2 meter Moxon prototype uses 3/16-inch diameter rod, while the 435 MHz version uses #12 AWG wire with a nominal 0.0808-inch diameter. Going one small step up or down in element diameter will still produce a usable antenna, but major diameter changes will require that the dimensions be recalculated. (Complete construction details and drawings are available with the online content.)

The antennas can be mounted on the same mast. However, for similar patterns, they should each be the same number of wavelengths above ground. For example, if the 2 meter antenna is about two wavelengths up at about 14 feet or so, then the bottom of the

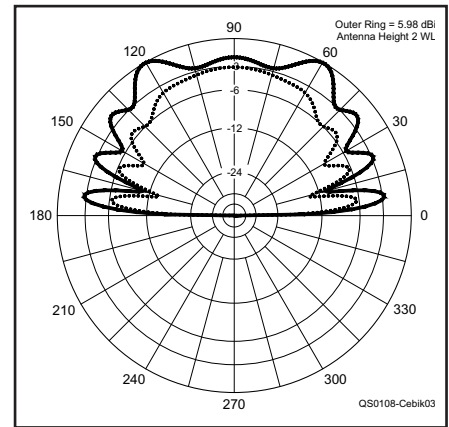

Figure 21.101 — A comparison of elevation patterns for the turnstile-and-screen system (with 3/8 λ wavelength spacing, shown by the solid black line) and a Moxon pair (dashed line), both at 2 λ height.

435-MHz antenna should be only about 4.5 feet above the ground. Placing the higher-frequency antenna below the 2 meter assembly will create some small irregularities in the desired dome pattern, but not serious enough to affect general operation.

There is no useful adjustment to these antennas except for making the gap between the drivers and reflectors as accurate as possible. Turnstile antennas show a very broad SWR curve. Across 2 meters, for example, the highest SWR is under 1.1:1. However, serious errors in the phasing line length can result in distortions to the desired circular pattern. There is no substitute for checking the lengths of the phasing line and the matching section several times before cutting. The correct length is from one junction to the next, including the portions of exposed cable interior.

Table 21.24
Dimensions for Moxon Rectangles for Satellite Use

Two are required for each antenna. The phase-line is 50-Ω coaxial cable, and the matching line is parallel sections of 75-Ω coaxial cable. Low power cables less than 0.15 inches in outer diameter were used in the prototypes. See Figure 21.102 for letter references. All dimensions are in inches.

Dimension	145.9 MHz	435.6 MHz
A	29.05	9.72
B	3.81	1.25
C	1.40	0.49
D	5.59	1.88
E (B + C + D)	10.80	3.62
¼ wavelength	20.22	6.77
Phasing and matching lines (0.66 velocity factor)	13.35	4.47

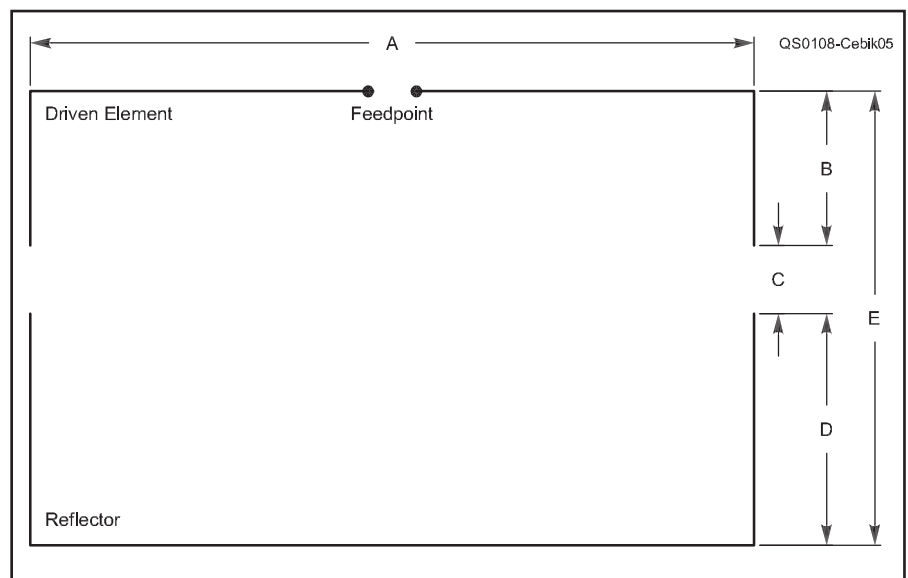

Figure 21.102 — The basic dimensions of a Moxon rectangle. Two identical rectangles are required for each “turnstiled” pair. See Table 21.24 for letter references.

21.12 Radio Direction Finding Antennas

Radio direction finding (RDF) is almost as old as radio communication. It gained prominence when the British Navy used it to track the movement of enemy ships in World War I. Since then, governments and the military have developed complex RDF systems. Fortunately, simple equipment, purchased or built at home, is quite effective in amateur radio RDF.

In European and Asian countries, direction-finding contests are foot races. The object is to be first to find four or five transmitters in a large wooded park. Young athletes have the best chance of capturing the prizes. This sport is known as *foxhunting* (after the British hill-and-dale horseback events) or *ARDF* (Amateur Radio Direction Finding). It is growing in popularity here in North America. Today, most competitive hunts worldwide are for 144 MHz FM signals, though other VHF bands are also used. Some international foxhunts include 3.5 MHz events.

In North America and England, most RDF contests involve mobiles — cars, trucks, and vans, even motorcycles. It may be possible to drive all the way to the transmitter, or there may be a short hike at the end, called a *sniff*. These competitions are also called foxhunting by some, while others use *bunny hunting*, *T-hunting*, or the classic term *hidden transmitter hunting*.

Even without participating in RDF contests, you will find knowledge of the techniques useful. They simplify the search for a neighborhood source of power-line interference or TV cable leakage. RDF must be used to track down emergency radio beacons, which signal the location of pilots and boaters in distress. Amateur radio enthusiasts skilled in transmitter hunting are in demand by agencies such as the Civil Air Patrol and the US Coast Guard Auxiliary for search and rescue support. RDF is an important part of the evidence-gathering process in interference cases.

The most basic RDF system consists of a directional antenna and a method of detecting and measuring the level of the radio signal, such as a receiver with signal strength indicator. RDF antennas range from a simple tuned loop of wire to an acre of antenna elements with an electronic beam-forming network. Other sophisticated techniques for RDF use the Doppler effect or measure the time of arrival difference of the signal at multiple antennas.

All of these methods have been used from 2 to 500 MHz and above. However, RDF practices vary greatly between the HF and VHF/UHF portions of the spectrum. For practical reasons, high gain beams, Dopplers, and switched dual antennas find favor on VHF/UHF, while loops and phased arrays are the most popular choices on 6 meters and below.

Signal propagation differences between HF and VHF also affect RDF practices. But many basic transmitter-hunting techniques, discussed later in this chapter, apply to all bands and all types of portable RDF equipment.

Several RDF projects may be found with the online content, along with a thorough article on Direction-Finding Techniques and mobile RDF system installation, including some examples of mobile RDF antenna mounting.

21.12.1 RDF Antennas for HF Bands

Below 50 MHz, gain antennas such as Yagis and quads are of limited value for RDF. The typical tribander installation yields only a general direction of the incoming signal, due to ground effects and the antenna's broad forward lobe. Long monoband beams at greater heights work better, but still cannot achieve the bearing accuracy and repeatability of simpler antennas designed specifically for RDF.

RDF LOOPS

An effective directional HF antenna can be as uncomplicated as a small loop of wire or tubing, tuned to resonance with a capacitor. When immersed in an electromagnetic field, the loop acts much the same as the secondary winding of a transformer. The voltage at the output is proportional to the amount of flux passing through it and the number of turns. If the loop is oriented such that the greatest amount of area is presented to the magnetic field, the induced voltage will be the highest. If it is rotated so that little or no area is cut by the field lines, the voltage induced in the loop is zero and a null occurs.

To achieve this transformer effect, the loop must be small compared with the signal wavelength. In a single-turn loop, the conductor should be less than 0.08λ long. For example, a 28 MHz loop should be less than 34 inches in circumference, giving a diameter of approximately 10 inches. The loop may be smaller, but that will reduce its voltage output. Maximum output from a small loop antenna is in directions corresponding to the plane of the loop; these lobes are very broad. Sharp nulls, obtained at right angles to that plane, are more useful for RDF.

For a perfect bidirectional pattern, the loop must be balanced electrostatically with respect to ground. Otherwise, it will exhibit two modes of operation, the mode of a perfect loop and that of a non-directional vertical antenna of small dimensions. This dual-mode condition results in mild to severe inaccuracy, depending on the degree of imbalance, because the outputs of the two modes are not in phase.

The theoretical true loop pattern is illus-

trated in **Figure 21.103**. When properly balanced, there are two nulls exactly 180° apart. When the unwanted antenna effect is appreciable and the loop is tuned to resonance, the loop may exhibit little directivity, as shown in **Figure 21.103B**. By detuning the loop to shift the phasing, you may obtain a useful pattern similar to **Figure 21.103C**. While not symmetrical, and not necessarily at right angles to the plane of the loop, this pattern does exhibit a pair of nulls.

By careful detuning and amplitude balancing, you can approach the unidirectional pattern of **Figure 21.103D**. Even though there may not be a complete null in the pattern, it resolves

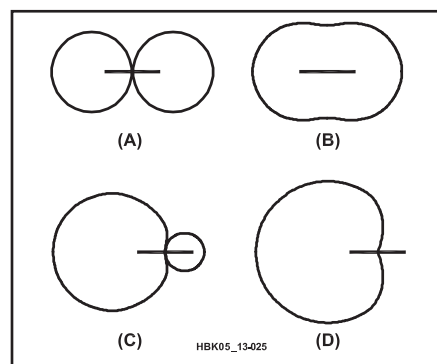

Figure 21.103 — Small loop field patterns with varying amounts of antenna effect — the undesired response of a loop acting merely as a mass of metal connected to the receiver antenna terminals. The horizontal lines show the plane of the loop turns.

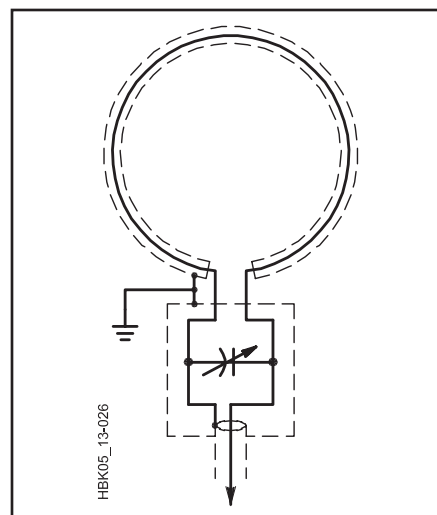

Figure 21.104 — Electrostatically shielded loop for RDF. To prevent shielding of the loop from magnetic fields, leave the shield unconnected at one end.

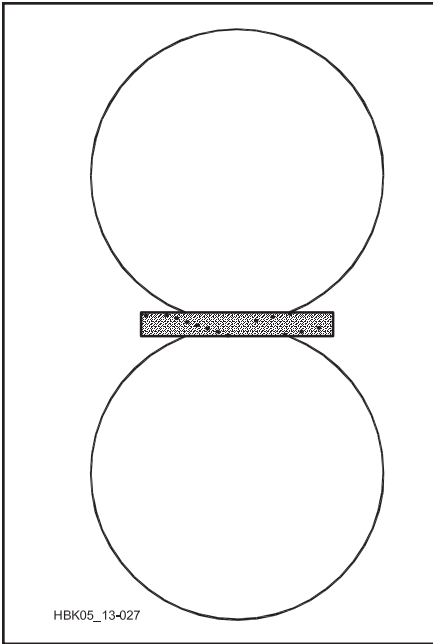

Figure 21.105 — Field pattern for a ferrite-rod antenna. The dark bar represents the rod on which the loop turns are wound.

the 180° ambiguity of Figure 21.103A. Korean War era military loop antennas, sometimes available on today's surplus market, use this controlled antenna effect principle.

An easy way to achieve good electrostatic balance is to shield the loop, as shown in **Figure 21.104**. The shield, represented by the dashed lines in the drawing, eliminates the antenna effect. The response of a well-constructed shielded loop is quite close to the ideal pattern of Figure 21.103A.

For 160 through 30 meters, single-turn loops that are small enough for portability are usually unsatisfactory for RDF work. Multi-turn loops are generally used instead. They are easier to resonate with practical capacitor values and give higher output voltages. This type of loop may also be shielded. If the total conductor length remains below 0.08λ , the directional pattern is that of Figure 21.103A.

FERRITE ROD ANTENNAS

Another way to get higher loop output is to increase the permeability of the medium in the vicinity of the loop. By winding a coil of wire around a form made of high-permeability material such as ferrite rod, much greater flux

is obtained in the coil without increasing the cross-sectional area.

Modern magnetic core materials make compact directional receiving antennas practical. Most portable AM broadcast receivers use this type of antenna, commonly called a *loopstick*. The loopstick is the most popular RDF antenna for portable/mobile work on 160 and 80 meters.

Like the shielded loop discussed earlier, the loopstick responds to the magnetic field of the incoming radio wave, and not to the electrical field. For a given size of loop, the output voltage increases with increasing flux density, which is obtained by choosing a ferrite core of high permeability and low loss at the frequency of interest. For increased output, the turns may be wound over two rods taped together. A practical loopstick antenna is described later in this chapter.

A loop on a ferrite core has maximum signal response in the plane of the turns, just like an air core loop. This means that maximum response of a loopstick is broadside to the axis of the rod, as shown in **Figure 21.105**. The loopstick may be shielded to eliminate the antenna effect; a U-shaped or C-shaped channel of aluminum or other form of "trough" is best. The shield must not be closed, and its length should equal or slightly exceed the length of the rod.

SENSE ANTENNAS

Because there are two nulls 180° apart in the directional pattern of a small loop or loopstick, there is ambiguity as to which null indicates the true direction of the target station. For example, if the line of bearing runs east and west from your position, you have no way of knowing from this single bearing whether the transmitter is east or west of you.

If bearings can be taken from two or more positions at suitable direction and distance from the transmitter, the ambiguity can be resolved and distance can be estimated by triangulation, as discussed later in this chapter. However, it is almost always desirable to be able to resolve the ambiguity immediately by having a unidirectional antenna pattern available.

You can modify a loop or loopstick antenna pattern to have a single null by adding a second antenna element. This element is called a *sense antenna*, because it senses the phase of the signal wavefront for comparison with the phase of the loop output signal. The sense element must be omnidirectional, such as a short vertical. When signals from the loop and the sense antenna are combined with 90° phase shift between the two, a heart-shaped (cardioid) pattern results, as shown in **Figure 21.106A**.

Figure 21.106B shows a circuit for adding a sense antenna to a loop or loopstick. For the best null in the composite pattern, signals from

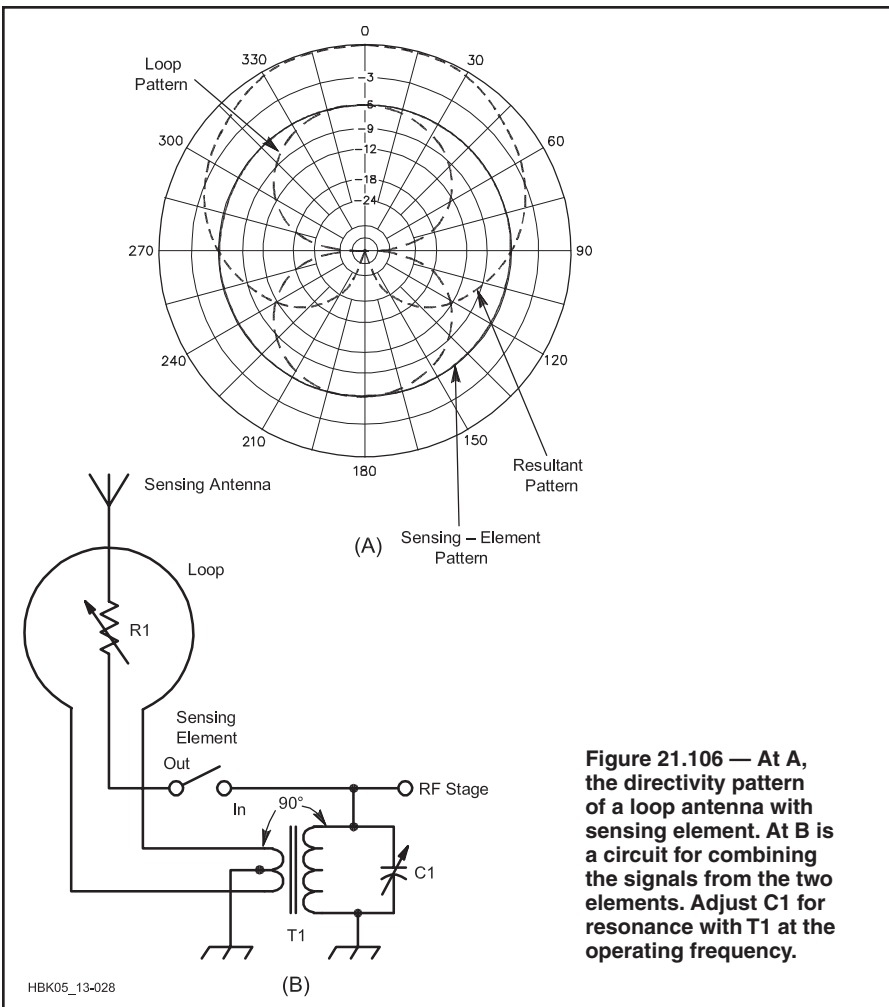

Figure 21.106 — At A, the directivity pattern of a loop antenna with sensing element. At B is a circuit for combining the signals from the two elements. Adjust C1 for resonance with T1 at the operating frequency.

the loop and sense antennas must be of equal amplitude. R1 adjusts the level of the signal from the sense antenna.

In a practical system, the cardioid pattern null is not as sharp as the bidirectional null of the loop alone. The usual procedure when transmitter hunting is to use the loop alone to obtain a precise line of bearing, then switch in the sense antenna and take another reading to resolve the ambiguity.

PHASED ARRAYS AND ADCOCK ANTENNAS

Two-element phased arrays are popular for amateur HF RDF base station installations. Many directional patterns are possible, depending on the spacing and phasing of the elements. A useful example is two $\frac{1}{2}\lambda$ elements spaced $\frac{1}{4}\lambda$ apart and fed 90° out of phase. The resultant pattern is a cardioid, with a null off one end of the axis of the two antennas and a broad peak in the opposite direction. The directional frequency range of this antenna is limited to one band, because of the critical length of the phasing lines.

The best-known phased array for RDF is the Adcock, named after the man who invented it in 1919. It consists of two vertical elements fed 180° apart, mounted so the array may be rotated. Element spacing is not critical, and may be in the range from 0.1 to 0.75λ . The two elements must be of identical lengths, but

need not be self-resonant; shorter elements are commonly used. Because neither the element spacing nor length is critical in terms of wavelengths, an Adcock array may operate over more than one amateur band.

Figure 21.107 is a schematic of a typical Adcock configuration, called the H-Adcock because of its shape. Response to a vertically polarized wave is very similar to a conventional loop. The passing wave induces currents I_1 and I_2 into the vertical members. The output current in the transmission line is equal to their difference. Consequently, the directional pattern has two broad peaks and two sharp nulls, like the loop. The magnitude of the difference current is proportional to the spacing (d) and length (l) of the elements. You will get somewhat higher gain with larger dimensions. The Adcock of **Figure 21.108**, designed for 40 meters, has element lengths of 12 feet and spacing of 21 feet (approximately 0.15λ).

Figure 21.109 shows the radiation pattern of the Adcock. The nulls are broadside to the axis of the array, becoming sharper with increased element spacing. When element spacing exceeds $\frac{3}{4}\lambda$, however, the antenna begins to take on additional unwanted nulls off the ends of the array axis.

The Adcock is a vertically polarized antenna. The vertical elements do not respond to horizontally polarized waves, and the currents induced in the horizontal members by a horizontally polarized wave (dotted arrows in **Figure 21.107**) tend to balance out regardless of the orientation of the antenna.

Since the Adcock uses a balanced feed system, a coupler is required to match the unbalanced input of the receiver. T1 is an air-wound coil with a two-turn link wrapped around the middle. The combination is resonated with C1 to the operating frequency. C2 and C3 are null-clearing capacitors. Adjust them by placing a low-power signal source some distance from the antenna and exactly broadside to it. Adjust C2 and C3 until the deepest null is obtained.

While you can use a metal support for the mast and boom, wood is preferable because of its non-conducting properties. Similarly, a mast of thick-wall PVC pipe gives less distortion of the antenna pattern than a metallic mast. Place the coupler on the ground below the wiring harness junction on the boom and connect it with a short length of $300\ \Omega$ twin-lead-feed line.

LOOPS VS PHASED ARRAYS

Loops are much smaller than phased arrays for the same frequency, and are thus the obvious choice for portable/mobile HF RDF. For base stations in a triangulation network, where the 180° ambiguity is not a problem, Adcocks are preferred. In general, they give sharper nulls than loops, but this is in part a function of the care used in constructing and feeding the individual antennas, as well as of the spac-

ing of the elements. The primary construction considerations are the shielding and balancing of the feed line against unwanted signal pickup and the balancing of the antenna for a symmetrical pattern. Users report that Adcocks are somewhat less sensitive to proximity effects, probably because their larger aperture offers some space diversity.

Skywave Considerations

Until now we have considered the directional characteristics of the RDF loop only in the two-dimensional azimuthal plane. In three-dimensional space, the response of a vertically oriented small loop is doughnut-shaped. The bidirectional null (analogous to a line through the doughnut hole) is in the line of bearing in the azimuthal plane and toward the horizon in the vertical plane. Therefore, maximum null depth is achieved only on signals arriving at 0° elevation angle.

Skywave signals usually arrive at nonzero wave angles. As the elevation angle increases,

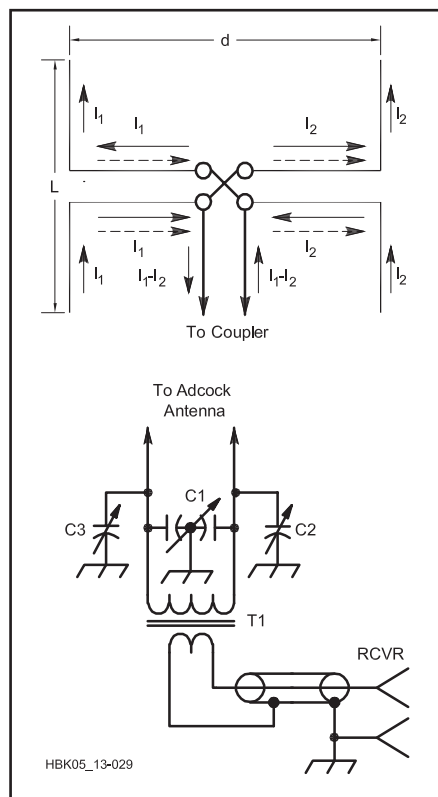

Figure 21.107 — A simple Adcock antenna and its coupler.

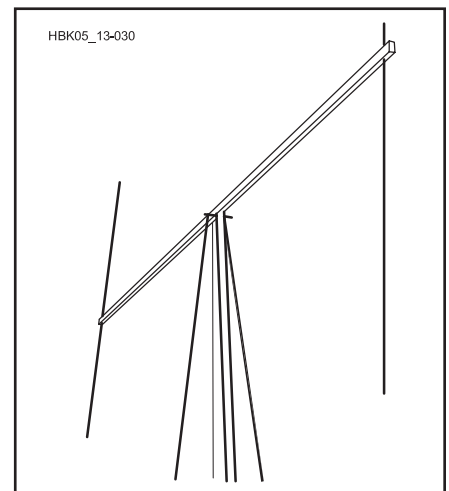

Figure 21.108 — An Adcock antenna on a wooden frame.

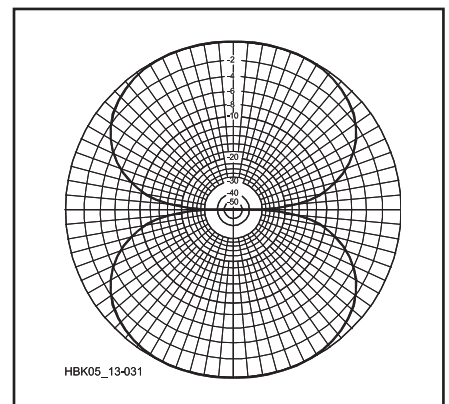

Figure 21.109 — The pattern of an Adcock array with element spacing of $\frac{1}{2}$ wavelength. The elements are aligned with the vertical axis.

the null in a vertically oriented loop pattern becomes shallower. It is possible to tilt the loop to seek the null in elevation as well as azimuth. Some amateur RDF enthusiasts report success at estimating distance to the target by measurement of the elevation angle with a tilted loop and computations based on estimated height of the propagating ionospheric layer. This method seldom provides high accuracy with simple loops, however.

Most users prefer Adcocks to loops for sky-wave work, because the Adcock null is present at all elevation angles. Note, however, that an Adcock has a null in all directions from signals arriving from overhead. Thus for very high angles, such as under-250-mile skip on 80 and 40 meters, neither loops nor Adcocks will perform well.

ELECTRONIC ANTENNA ROTATION

State-of-the-art fixed RDF stations for government and military work use antenna arrays of stationary elements, rather than mechanically rotatable arrays. The best-known type is the *Wullenweber antenna*. It has a large number of elements arranged in a circle, usually outside of a circular reflecting screen. Depending on the installation, the circle may be anywhere from a few hundred feet to more than a quarter of a mile in diameter. Although the Wullenweber is not practical for most amateurs, some of the techniques it uses may be applied to amateur RDF.

The device, which permits rotating the antenna beam without moving the elements, has the classic name *radio goniometer*, or simply *goniometer*. Early goniometers were RF transformers with fixed coils connected to the array elements and a moving pickup coil connected to the receiver input. Both amplitude and phase of the signal coupled into the pickup winding are altered with coil rotation in a way that corresponded to actually rotating the array itself. With sufficient elements and a goniometer, accurate RDF measurements can be taken in all compass directions.

Beam Forming Networks

By properly sampling and combining signals from individual elements in a large array, an antenna beam is electronically rotated or steered. With an appropriate number and arrangement of elements in the system, it is possible to form almost any desired antenna pattern by summing the sampled signals in appropriate amplitude and phase relationships. Delay networks and/or attenuation are added in line with selected elements before summation to create these relationships.

To understand electronic beam forming, first consider just two elements, shown as A and B in **Figure 21.110**. Also shown is the wavefront of a radio signal arriving from a distant transmitter. The wavefront strikes element A first, then travels somewhat farther

before it strikes element B. Thus, there is an interval between the times that the wavefront reaches elements A and B.

We can measure the differences in arrival times by delaying the signal received at element A before summing it with that from element B. If two signals are combined directly, the amplitude of the sum will be maximum when the delay for element A exactly equals the propagation delay, giving an in-phase condition at the summation point. On the other hand, if one of the signals is inverted and the two are added, the signals will combine in a 180° out-of-phase relationship when the element A delay equals the propagation delay, creating a null. Either way, once the time delay is determined by the amount of delay required for a peak or null, we can convert it to distance. Then trigonometry calculations provide the direction from which the wave is arriving.

Altering the delay in small increments steers the peak (or null) of the antenna. The system is not frequency sensitive, other than the frequency range limitations of the array elements. Lumped-constant networks are suitable for delay elements if the system is used only for receiving. Delay lines at installations used for transmitting and receiving employ rolls of coaxial cable of various lengths, chosen for the time delay they provide at all frequencies, rather than as simple phasing lines designed for a single frequency.

Combining signals from additional elements narrows the broad beamwidth of the pattern from the two elements and suppresses unwanted sidelobes. Electronically switching the delays and attenuations to the various elements causes the formed beam to rotate around the compass. The package of electronics that does this, including delay lines and electronically switched attenuators, is the beam-forming network.

21.12.2 Methods for VHF/UHF RDF

Three distinct methods of mobile RDF are commonly in use by amateurs on VHF/UHF

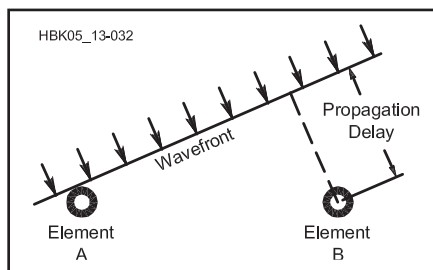

Figure 21.110 — One technique used in electronic beam forming. By delaying the signal from element A by an amount equal to the propagation delay, two signals are summed precisely in phase, even though the signal is not in the broadside direction.

bands: directional antennas, switched dual antennas and Dopplers. Each has advantages over the others in certain situations. Many RDF enthusiasts employ more than one method when transmitter hunting.

DIRECTIONAL ANTENNAS

Ordinary mobile transceivers and handhelds work well for foxhunting on the popular VHF bands. If you have a lightweight beam and your receiver has an easy-to-read S meter, you are nearly ready to start. All you need is an RF attenuator and some way to mount the setup in your vehicle.

Amateurs seldom use fractional wavelength loops for RDF above 60 MHz because they have bidirectional characteristics and low sensitivity, compared to other practical VHF antennas. Sense circuits for loops are difficult to implement at VHF, and signal reflections tend to fill in the nulls. Typically VHF loops are used only for close-in sniffing where their compactness and sharp nulls are assets, and low gain is of no consequence.

Phased Arrays

The small size and simplicity of two-element driven arrays make them a common choice of newcomers at VHF RDF. Antennas such as phased ground planes and ZL Specials have modest gain in one direction and a null in the opposite direction. The gain is helpful when the signal is weak, but the broad response peak makes it difficult to take a precise bearing.

As the signal gets stronger, it becomes possible to use the null for a sharper S meter indication. However, combinations of direct and reflected signals (called *multipath*) will distort the null or perhaps obscure it completely. For best results with this type of antenna, always find clear locations from which to take bearings.

Parasitic Arrays

Parasitic arrays are the most common RDF antennas used by transmitter hunters in high competition areas such as Southern California. Antennas with significant gain are a necessity due to the weak signals often encountered on weekend-long T-hunts, where the transmitter may be over 200 miles distant. Typical 144 MHz installations feature Yagis or quads of three to six elements, sometimes more. Quads are typically home-built, using data from *The ARRL Antenna Book* and *Transmitter Hunting* (see Bibliography).

Two types of mechanical construction are popular for mobile VHF quads. One model uses thin gauge wire (solid or stranded) suspended on wood dowel or fiberglass rod spreaders. It is lightweight and easy to turn rapidly by hand while the vehicle moves. Many hunters prefer to use larger gauge solid wire (such as #10 AWG) on a PVC plastic pipe frame. This quad is more rugged and

has somewhat wider frequency range, at the expense of increased weight and wind resistance. It can get bent going under a branch, but it is easily reshaped and returned to service.

Yagis are a close second to quads in popularity. Commercial models work fine for VHF RDF, provided that the mast is attached at a good balance point. Lightweight and small-diameter elements are desirable for ease of turning at high speeds.

A well-designed mobile Yagi or quad installation includes a method of selecting wave polarization. Although vertical polarization is the norm for VHF-FM communications, horizontal polarization is allowed on many T-hunts. Results will be poor if a VHF RDF antenna is cross-polarized to the transmitting antenna, because multipath and scattered signals (which have indeterminate polarization) are enhanced, relative to the cross-polarized direct signal. The installation of **Figure 21.111** features a slip joint at the boom-to-mast junction, with an actuating cord to rotate the boom, changing the polarization. Mechanical stops limit the boom rotation to 90°.

Parasitic Array Performance for RDF

The directional gain of a mobile beam (typically 8 dB or more) makes it unexcelled for both weak signal competitive hunts and for locating interference such as TV cable leakage. With an appropriate receiver, you can get bearings on any signal mode, including FM, SSB, CW, TV, pulses, and noise. Because only the response peak is used, the null-fill problems and proximity effects of loops and phased arrays do not exist.

You can observe multiple directions of arrival while rotating the antenna, allowing you to make educated guesses as to which signal peaks are direct and which are from non-direct

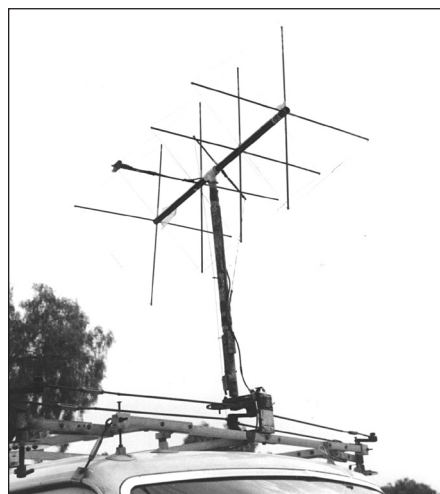

Figure 21.111 — The mobile RDF installation of WB6ADC features a thin wire quad that can be switched between vertical and horizontal polarization.

paths or scattering. Skilled operators can estimate distance to the transmitter from the rate of signal strength increase with distance traveled. The RDF beam is useful for transmitting, if necessary, but use care not to damage an attenuator in the coax line by transmitting through it.

The 3 dB beamwidth of typical mobile-mount VHF beams is on the order of 80°. This is a great improvement over 2-element driven arrays, but it is still not possible to get pinpoint bearing accuracy. You can achieve errors of less than 10° by carefully reading the S meter. In practice, this is not a major hindrance to successful mobile RDF. Mobile users are not as concerned with precise bearings as fixed station operators, because mobile readings are used primarily to give the general direction of travel to “home in” on the signal. Mobile bearings are continuously updated from new, closer locations.

Amplitude-based RDF may be very difficult when signal level varies rapidly. The transmitter hider may be changing power, or the target antenna may be moving or near a well-traveled road or airport. The resultant rapid S meter movement makes it hard to take accurate bearings with a quad. The process is slow because the antenna must be carefully rotated by hand to “eyeball average” the meter readings.

SWITCHED ANTENNA RDF UNITS

Three popular types of RDF systems are relatively insensitive to variations in signal level. Two of them use a pair of vertical dipole antennas, spaced $\frac{1}{2} \lambda$ or less apart, and alternately switched at a rapid rate to the input of the receiver. In use, the indications of the two systems are similar, but the principles are different.

Switched Pattern Systems

The switched pattern RDF set (**Figure 21.112**) alternately creates two cardioid an-

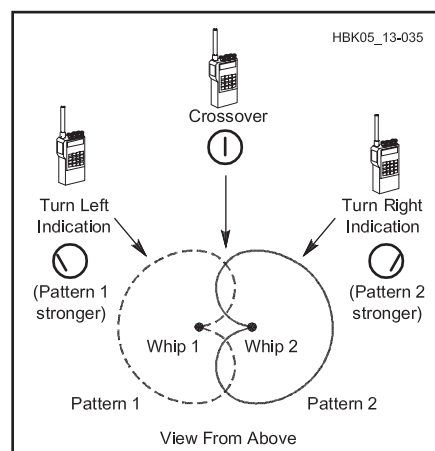

Figure 21.112 — In a switched pattern RDF set, the responses of two cardioid antenna patterns are summed to drive a zero center indicator.

tenna patterns with lobes to the left and the right. The patterns are generated in much the same way as in the phased arrays described above. PIN RF diodes select the alternating patterns. The combined antenna outputs go to a receiver with AM detection. Processing after the detector output determines the phase or amplitude difference between the patterns’ responses to the signal.

Switched pattern RDF sets typically have a zero center meter as an indicator. The meter swings negative when the signal is coming from the user’s left, and positive when the signal source is on the right. When the plane of the antenna is exactly perpendicular to the direction of the signal source, the meter reads zero.

The sharpness of the zero crossing indication makes possible more precise bearings than those obtainable with a quad or Yagi. Under ideal conditions with a well-built unit, null direction accuracy is within 1°. Meter deflection tells the user which way to turn to zero the meter. For example, a negative (left) reading requires turning the antenna left. This solves the 180° ambiguity caused by the two zero crossings in each complete rotation of the antenna system.

Because it requires AM detection of the switched pattern signal, this RDF system finds its greatest use in the 120 MHz aircraft band, where AM is the standard mode. Commercial manufacturers make portable RDF sets with switched pattern antennas and built-in receivers for field portable use. These sets can usually be adapted to the amateur 144 MHz band. Other designs are adaptable to any VHF receiver that covers the frequency of interest and has an AM detector built in or added.

Switched pattern units work well for RDF from small aircraft, for which the two vertical antennas are mounted in fixed positions on the outside of the fuselage or simply taped inside the windshield. The left-right indication tells the pilot which way to turn the aircraft to home in. Since street vehicles generally travel only on roads, fixed mounting of the antennas on them is undesirable. Mounting vehicular switched-pattern arrays on a rotatable mast is best.

Time-of-Arrival Systems

Another kind of switched antenna RDF set uses the difference in arrival times of the signal wavefront at the two antennas. This narrow-aperture Time-Difference-of-Arrival (TDOA) technology is used for many sophisticated military RDF systems. The rudimentary TDOA implementation of **Figure 21.113** is quite effective for amateur use. The signal from transmitter 1 reaches antenna A before antenna B. Conversely, the signal from transmitter 3 reaches antenna B before antenna A. When the plane of the antenna is perpendicular to the signal source (as transmitter 2 is in

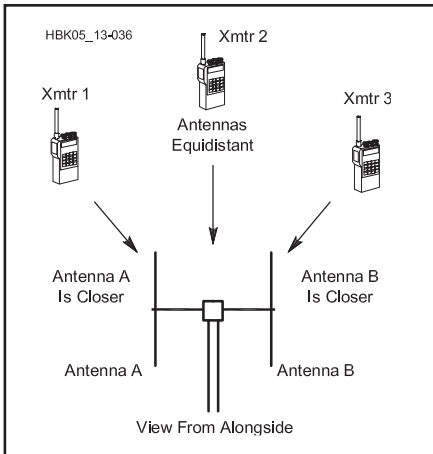

Figure 21.113 — A dual-antenna TDOA RDF system has a similar indicator to a switched pattern unit, but it obtains bearings by determining which of its antennas is closer to the transmitter.

the figure), the signal arrives at both antennas simultaneously.

If the outputs of the antennas are alternately switched at an audio rate to the receiver input, the differences in the arrival times of a continuous signal produce phase changes that are detected by an FM discriminator. The resulting short pulses sound like a tone in the receiver output. The tone disappears when the antennas are equidistant from the signal source, giving an audible null.

The polarity of the pulses at the discriminator output is a function of which antenna is closer to the source. Therefore, the pulses can be processed and used to drive a left-right zero-center meter in a manner similar to the switched pattern units described above. Left-right LED indicators may replace the meter for economy and visibility at night.

RDF operations with a TDOA dual antenna RDF are done in the same manner as with a switched antenna RDF set. The main difference is the requirement for an FM receiver in the TDOA system and an AM receiver in the switched pattern case. No RF attenuator is needed for close-in work in the TDOA case.

Popular designs for practical do-it-yourself TDOA RDF sets include the Simple Seeker (described elsewhere in this chapter) and the W9DUU design (see article by Bohrer in the Bibliography). Articles with plans for the Handy Tracker, a simple TDOA set with a delay line to resolve the dual-null ambiguity instead of LEDs or a meter, are listed in the Bibliography.

Performance Comparison

Both types of dual antenna RDFs make good on-foot “sniffing” devices and are excellent performers when there are rapid amplitude variations in the incoming signal. They are the

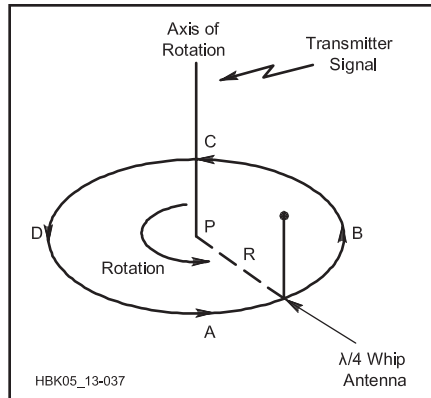

Figure 21.114 — A theoretical Doppler antenna circles around point P, continuously moving toward and away from the source at an audio rate.

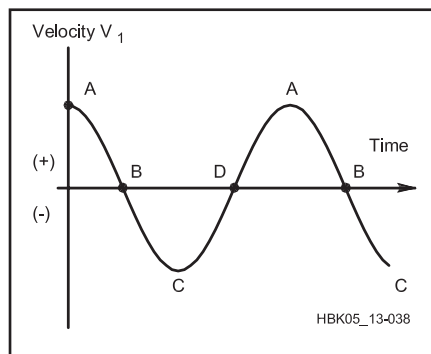

Figure 21.115 — Frequency shift versus time produced by the rotating antenna movement toward and away from the signal source.

units of choice for airborne work. Compared to Yagis and quads, they give good directional performance over a much wider frequency range. Their indications are more precise than those of beams with broad forward lobes.

Dual-antenna RDF sets frequently give inaccurate bearings in multipath situations, because they cannot resolve signals of nearly equal levels from more than one direction. Because multipath signals are a combined pattern of peaks and nulls, they appear to change in amplitude and bearing as you move the RDF antenna along the bearing path or perpendicular to it, whereas a non-multipath signal will have constant strength and bearing.

The best way to overcome this problem is to take large numbers of bearings while moving toward the transmitter. Taking bearings while in motion averages out the effects of multipath, making the direct signal more readily discernible. Some TDOA RDF sets have a slow-response mode that aids the averaging process.

Switched antenna systems generally do not perform well when the incoming signal is horizontally polarized. In such cases, the bearings

may be inaccurate or unreadable. TDOA units require a carrier type signal such as FM or CW; they usually cannot yield bearings on noise or pulse signals.

Unless an additional method is employed to measure signal strength, it is easy to “overshoot” the hidden transmitter location with a TDOA set. It is not uncommon to see a TDOA foxhunter walk over the top of a concealed transmitter and walk away, following the opposite 180° null, because there is no display of signal amplitude.

DOPPLER RDF SETS

RDF sets using the Doppler principle are popular in many areas because of their ease of use. They have an indicator that instantaneously displays direction of the signal source relative to the vehicle heading, either on a circular ring of LEDs or a digital readout in degrees. A ring of four, eight, or more antennas picks up the signal. Quarter-wavelength monopoles on a ground plane are popular for vehicle use, but half-wavelength vertical dipoles, where practical, perform better.

Radio signals received on a rapidly moving antenna experience a frequency shift due to the Doppler effect, a phenomenon well known to anyone who has observed a moving car with its horn sounding. The horn’s pitch appears higher than normal as the car approaches, and lower as the car recedes. Similarly, the received radio frequency increases as the antenna moves toward the transmitter and vice versa. An FM receiver will detect this frequency change.

Figure 21.114 shows a $\frac{1}{4}\lambda$ vertical antenna being moved on a circular track around point P, with constant angular velocity. As the antenna approaches the transmitter on its track, the received frequency is shifted higher. The highest instantaneous frequency occurs when the antenna is at point A, because tangential velocity toward the transmitter is maximum at that point. Conversely, the lowest frequency occurs when the antenna reaches point C, where velocity is maximum away from the transmitter.

Figure 21.115 shows a plot of the component of the tangential velocity that is in the direction of the transmitter as the antenna moves around the circle. Comparing Figures 21.114 and 21.115, notice that at B in Figure 21.115, the tangential velocity is crossing zero from the positive to the negative and the antenna is closest to the transmitter. The Doppler shift and resulting audio output from the receiver discriminator follow the same plot, so that a negative-slope zero-crossing detector, synchronized with the antenna rotation, senses the incoming direction of the signal.

The amount of frequency shift due to the Doppler effect is proportional to the RF frequency and the tangential antenna velocity. The velocity is a function of the radius of ro-

tation and the angular velocity (rotation rate). The radius of rotation must be less than $\frac{1}{4} \lambda$ to avoid errors. To get a usable amount of FM deviation (comparable to typical voice modulation) with this radius, the antenna must rotate at approximately 30,000 RPM (500 Hz). This puts the Doppler tone in the audio range for easy processing.

Mechanically rotating a whip antenna at this rate is impractical, but a ring of whips, switched to the receiver in succession with RF PIN diodes, can simulate a rapidly rotating antenna. Doppler RDF sets must be used with receivers having FM detectors. The Dopple ScAnt and Roanoke Doppler (see Bibliography) are mobile Doppler RDF sets designed for inexpensive home construction.

Doppler Advantages and Disadvantages

Ring-antenna Doppler sets are the ultimate in simplicity of operation for mobile RDF.

There are no moving parts and no manual antenna pointing. Rapid direction indications are displayed on very short signal bursts.

Many units lock in the displayed direction after the signal leaves the air. Power variations in the source signal cause no difficulties, as long as the signal remains above the RDF detection threshold. A Doppler antenna goes on top of any car quickly, with no holes to drill. Many Local Interference Committee members choose Dopplers for tracking malicious interference, because they are inconspicuous (compared to beams) and effective at tracking the strong vertically polarized signals that repeater jammers usually emit.

A Doppler does not provide superior performance in all VHF RDF situations. If the signal is too weak for detection by the Doppler unit, the hunt advantage goes to teams with beams. Doppler installations are not suitable for on-foot sniffing. The limitations of other switched

antenna RDFs also apply: (1) poor results with horizontally polarized signals, (2) no indication of distance, (3) carrier type signals only, and (4) inadvisability of transmitting through the antenna.

Readout to the nearest degree is provided on some commercial Doppler units. This does not guarantee that level of accuracy, however. A well-designed four-monopole set is typically capable of $\pm 5^\circ$ accuracy on 2 meters, if the target signal is vertically polarized and there are no multipath effects.

The rapid antenna switching can introduce cross modulation products when the user is near strong off-channel RF sources. This self-generated interference can temporarily render the system unusable. While not a common problem with mobile Dopplers, it makes the Doppler a poor choice for use in remote RDF installations at fixed sites with high power VHF transmitters nearby.

21.13 Rotators

The rotator is an important component of directional antenna systems, turning the antenna to any direction with a repeatable accuracy of a few degrees. Once in position, the rotator must hold the antenna in place against the wind. The rotator must do this while supporting the weight of the mast and all of the antennas.

Although mechanical details vary, a rotator consists of a base assembly mounted to a fixed mast or tower and a rotating assembly atop it with a clamp in which the antenna support mast is held. The turning motor and gear train, brake, position indicator, and limit switches are installed in or on the base. The rotating assembly sits on a bearing race resting on the base assembly. A ring gear is the most common method of transferring the motor's rotation to the rotating housing, although worm gears are also used.

Rotators are usually installed inside a lattice tower section that uses a sleeve or thrust bearing to hold a mast and stabilize it against sideways torque. The sleeve is part of the tower's top section. A thrust bearing is mounted on a bearing plate at the top of the tower. The rotator is mounted on a rotator shelf that sits inside the tower and is sold as an accessory by the tower manufacturer. Smaller rotators usually come with a mast clamp so they can be mounted on a pipe or similar mast with the antenna directly above them. **Figure 21.116** shows typical installations.

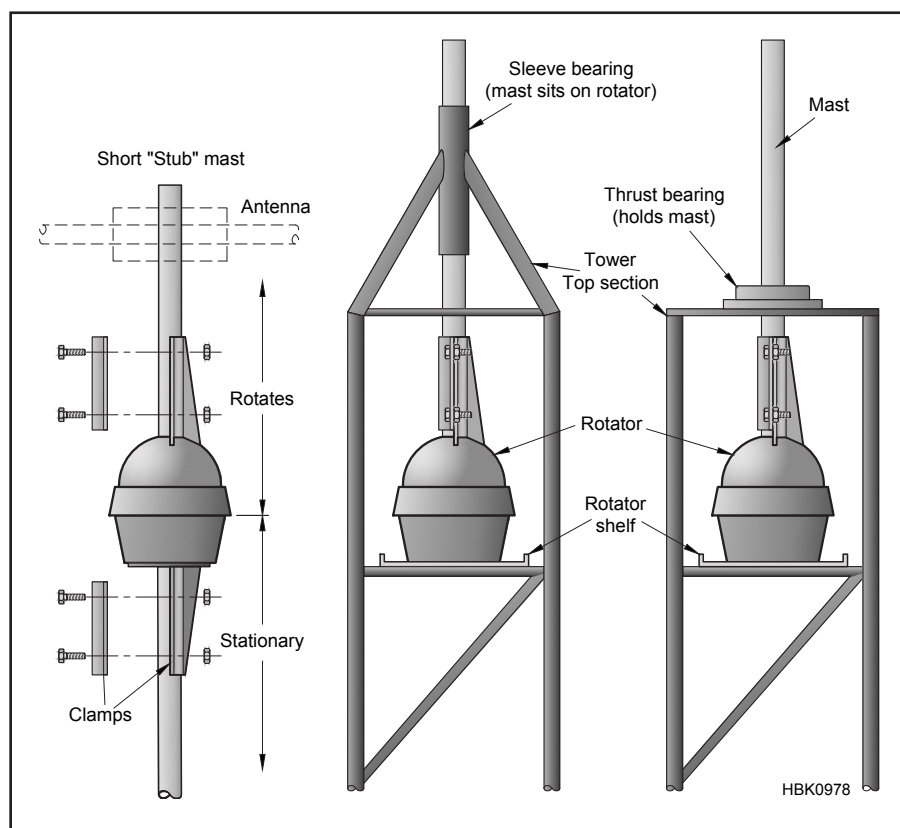

Figure 21.116 — Rotators can be mounted directly on masts or inside lattice-style towers. Rotators can also be mounted directly on the top of towers (not shown).

21.13.1 Rotator Ratings

Rotators are expected to work for many years over a very wide range of temperatures while exposed to the elements, with little or no maintenance. To achieve those performance goals, the rotator's specifications and installation requirements must be respected.

There are three primary rotator ratings: *wind load*, *braking ability*, and *turning torque*. Many rotators also specify a maximum *vertical load* in pounds or kilograms. **Table 21.25** lists manufacturers for rotators intended for fixed-station installations, and **Table 21.26** shows the primary ratings for common rotators.

Wind load is specified both with the rotator mounted inside a tower and with the rotator outside a tower mounted on a mast (see Figure 21.116). When mounted inside a tower section, the tower holds the mast in place straight above the rotator, often using a thrust bearing to hold the mast in place. This eliminates any

sideways load on the rotating assembly relative to the base. Wind load ratings are given as a maximum antenna area in square feet, and antenna manufacturers specify the area of their beams for this reason. In the US, wind load calculations are based on the standard EIA/TIA-222-G:2005-08-02. In Europe, EN 1991-1-4 is the current standard, corresponding to the German standard DIN 1055-4.

Braking ability is the maximum twisting force the rotator can withstand when stopped. This force is primarily created by the wind. The rotator's braking action is provided either by a solenoid-controlled wedge or bar inside the housing, or by a worm-gear drive that does not allow backward rotation of the mast under load. Turning torque is the maximum amount of torque the rotator can produce to turn the antennas. Both braking ability and turning torque are given in inch-pounds.

Effective moment is the product of antenna

weight in pounds (or kilograms) and turning radius in feet (or meters). Heavy antennas and bigger antennas are harder to turn and to hold in place against the wind, requiring a higher effective moment rating for the rotator. Hy-Gain uses effective moment as a maximum rating for its line of rotators.

It is important not to overload a rotator. If you live in a location that is prone to high winds, persistent winds, or large gusts, include a safety factor when selecting a rotator. Persistent twisting from winds can wear out a rotator's brake wedge or housing indentations that hold the brake in place. This can cause the brake to slip or jam. Rotators are not inexpensive, and a failed rotator brake can allow an antenna to "freewheel," damaging the feed line as well. A thrust bearing at the top of the tower can be used to hold the weight of a large antenna array, leaving only the turning load on the rotator.

Table 21.25
Rotator Manufacturers and Service (Fixed Station)

Manufacturers

Alpha-Spid	www.alfaradio.ca
Channel Master	www.channelmaster.com
DX Engineering	www.dxengineering.com
Hy-Gain	www.hy-gain.com
M ²	www.m2inc.com
TIC	www.ticgen.com
Yaesu	www.yaesu.com
<i>Service</i>	
C.A.T.S.	www.rotor-doc.com
Norm's Rotor Service	www.rotorservice.com

"Rotator" or "Rotor"?

The piece of equipment installed on the tower that makes the antennas turn is a "rotator." A "rotor" is the rotary part of a motor or vehicle. For example, the blades of a helicopter form its rotor and the spinning shaft and armature of an electric motor form its rotor. The rotator includes the entire machine, both the stationary and moving parts, making the antenna system turn. Amateurs use both words, rotator and rotor, somewhat interchangeably.

Table 21.26
Common Rotator Specifications

Mfr	Model	Wind Load (in tower, sq ft)	Wind Load (outside tower, sq ft)	Turning Torque (in-lb)	Braking Ability (in-lb)	Effective Moment (ft-lb)	Brake Type	Notes
Alpha-Spid	RAK1			1400	>14,000		Worm gear	Heavy-duty
Channel Master	9521HD			100				Light-duty
DX Engineering	RT4500HD*	>35	n/a	>3300	>20,000		Gear reduction	Heavy-duty
Hy-Gain	T2X	20	10	1000	9000	3400	Wedge	Heavy-duty
	AR-40	3	1.5	350	450	300	Disc	Light-duty
	CD-45II	8.5	5	600	800	1200	Disc	Medium-duty
	HAM-IV	15	7.5	800	5000	2800	Wedge	Medium-duty
	HDR-300A	25	n/a	5000	7500		Solenoid lock	Heavy-duty
M ²	OR2800	35	n/a	3200	17000		Gear reduction	Heavy-duty
TIC	1022D			6500	6500		Gear reduction	Heavy-duty, ring mount
	1032D			7881	7530		Gear reduction	Heavy-duty, ring mount
Yaesu	G-450A	10.8	5.4	516	2604		Gear reduction	Light-duty
	G-800DXA	21.5	8	955	3472		Mech and elec	Medium-duty
	G-1000DXA	23.7	8	955	5207		Mech and elec	Medium-duty
	G-2800DXA	32.3	10.8	2170	21700		Mech and elec	Heavy-duty
<i>Az-EI Rotators</i>								
Yaesu	G-5500	10.8	10.8	428	3468		Gear reduction	
Alpha-Spid	RAS-1	30		1400	14,000s		Worm gear	At 12 V
	RAS-2			1400	14,000s		Worm gear	
	REAL-1			1400	14,000s		Worm gear	

*Preliminary specifications; final data not available at publication time.

What is an Armstrong Rotator?

The term “armstrong” refers to anything turned or lifted manually, requiring a “strong arm.” There are many examples of hams using gears or cranks to turn antennas but the most common is a rope tied to the antenna’s boom and pulled from ground level. The antenna’s mast turns freely in the tower or the antenna mount turns on the mast. This is a common temporary solution during antenna system repair or when operating during Field Day and portable.

21.13.2 Types of Rotators

Amateur rotators range from very light-duty models intended for TV antennas all the way to reconditioned “prop-pitch” rotators designed originally to control the pitch or angle of aircraft propeller blades. There are also models for portable and temporary use.

Light-duty antenna rotators are suitable for small VHF and UHF Yagis or log-periodic antennas. They should not be used with HF antennas, large microwave dishes, or antenna systems with a significant wind load.

Medium-duty rotators can handle a single, mid-sized HF tribander or log-periodic. A small VHF/UHF Yagi can be stacked with the HF beam. These rotators are also good choices for a stack of VHF/UHF antennas. Dish antennas should be evaluated to be sure they won’t overload these rotators.

Heavy-duty rotators are able to handle the biggest amateur HF Yagis, including stacks of two or three antennas. Instead of a solenoid brake, some of these rotators use a gear train or worm-drive to provide the braking action. Be sure the tower and supporting hardware are rated to handle the antenna and mast load. These rotators are somewhat larger than the more common medium-duty models and may be difficult to install in smaller lattice-style towers.

Ring rotators, or orbital ring rotators, are a special type of rotator installed outside the tower, attached to its legs. The antenna is carried by a motorized cradle that moves around the tower on a circular, toothed track that acts as a drive gear. Ring rotators are generally used at big stations that use large, stacked HF Yagis.

It is also possible to simply rotate the entire tower with a variety of antennas mounted directly on the tower. The guy wires are attached to bearing rings, allowing the tower to turn inside them.

21.13.3 Rotator Control

TURNING CONTROL

There are two steps in controlling turning; releasing the brake, if any, and energizing a motor to turn in the desired direction.

An electrically controlled brake consists of a heavy-duty solenoid and a spring-loaded brake wedge or bar that fits into indentations inside the rotating assembly. The rotator’s braking

torque is determined by how securely the brake is held by the indentations or, if worm gears are used, by the resistance to the gears turning backward under load. To turn the rotator, the solenoid is energized, pulling the brake out of the indentations. Energizing the solenoid is usually the largest current draw of the rotator.

The most common rotator motor is a 2-phase ac motor with a starting capacitor. The capacitor is switched between phases to control direction of rotation. Because of gear reduction, the motor can be fairly small and does not draw much current. Unless blocked by an obstruction, rotators turn a full 360 degrees. Limit switches open at the ends of rotation, removing power from the motor at the extreme ends of travel to prevent feed line damage.

When rotation is complete, the solenoid is de-energized and the brake reengages the indentations, holding the mast in place. Over time, the indentations or brake can wear out, allowing the rotating housing to slip under heavy loads. Wear is accelerated by de-energizing the solenoid while the mast is still turning, causing the brake to impact the sides of the indentations. To reduce the impact of sudden stops, some controllers allow the mast to stop turning before de-energizing the solenoid. Typical brake delays are about 5 seconds. (Retrofit delay modules are available for the Hy-Gain family of rotators.) If your rotator does not have a brake delay, practice keeping the brake energized for a few seconds after you release the turning controls to allow the antennas to stop moving first.

POSITION INDICATION

There are two basic types of position indication — resistance and pulse counting. The most common circuit is a potentiometer (“pot”) contained in the rotator’s housing and turned in sync with the rotator motor. Current through the pot (typically only a few milliamps) drives

an analog meter in the control unit calibrated in degrees. Rotators using pulse counters use a switch to generate pulses that the control unit counts to calculate the number of degrees from one end of travel.

Most rotator controllers in North America are configured as “North center,” meaning they can turn an antenna from pointing directly south at one limit, through north at mid-travel, and all the way to south again at the opposite limit. North is the center position on the meter displaying the antenna’s direction. (South center meter scales are an option for most rotators.)

To calibrate a pot-indicator rotator’s direction assuming North center, first, calibrate the direction indicator. Then move the rotator to its mid-travel orientation so that it indicates north. Loosen the antenna mast clamp and rotate the mast until the antennas point directly north and re-tighten the clamp. (Using a compass or landmark is sufficient resolution for most amateur antennas.) When storing or testing a rotator, make a practice of leaving it set to mid-travel for ease of position calibration and mark or tag it for later reference. For a pulse-count rotator, the manufacturer’s manual will provide the necessary directions.

ROTATOR WIRING

The ARRL appreciates being granted permission by the Hy-Gain Company to reproduce the wiring diagram of the control unit for its widely used Ham-IV and Tailtwister T2X rotators as a convenience for readers. (See **Figure 21.117**.)

Rotator Software Control

Recently-designed rotator control units have RS-232 or USB interfaces that act as COM ports to PC software. There are several different protocols, the Yaesu protocol being the most common. The Rotor-EZ and ERC interfaces can be added to most rotators that don’t have a software interface. Logging software often supports several different protocols and standalone software packages and utilities are also available—internet searches for “antenna rotator software control” will find many programs.

One Control for All

Each rotator family (Ham-IV, Yaesu, M², and so on) comes with a custom control unit for turning and position display. There are also after-market control units that operate with any of the common rotators. The most widely used are the Green Heron controllers (www.greenheronengineering.com) and the EA4TX interfaces (ea4tx.com). Both can control most available models of rotators, allowing you to standardize in the station and customize on the tower.

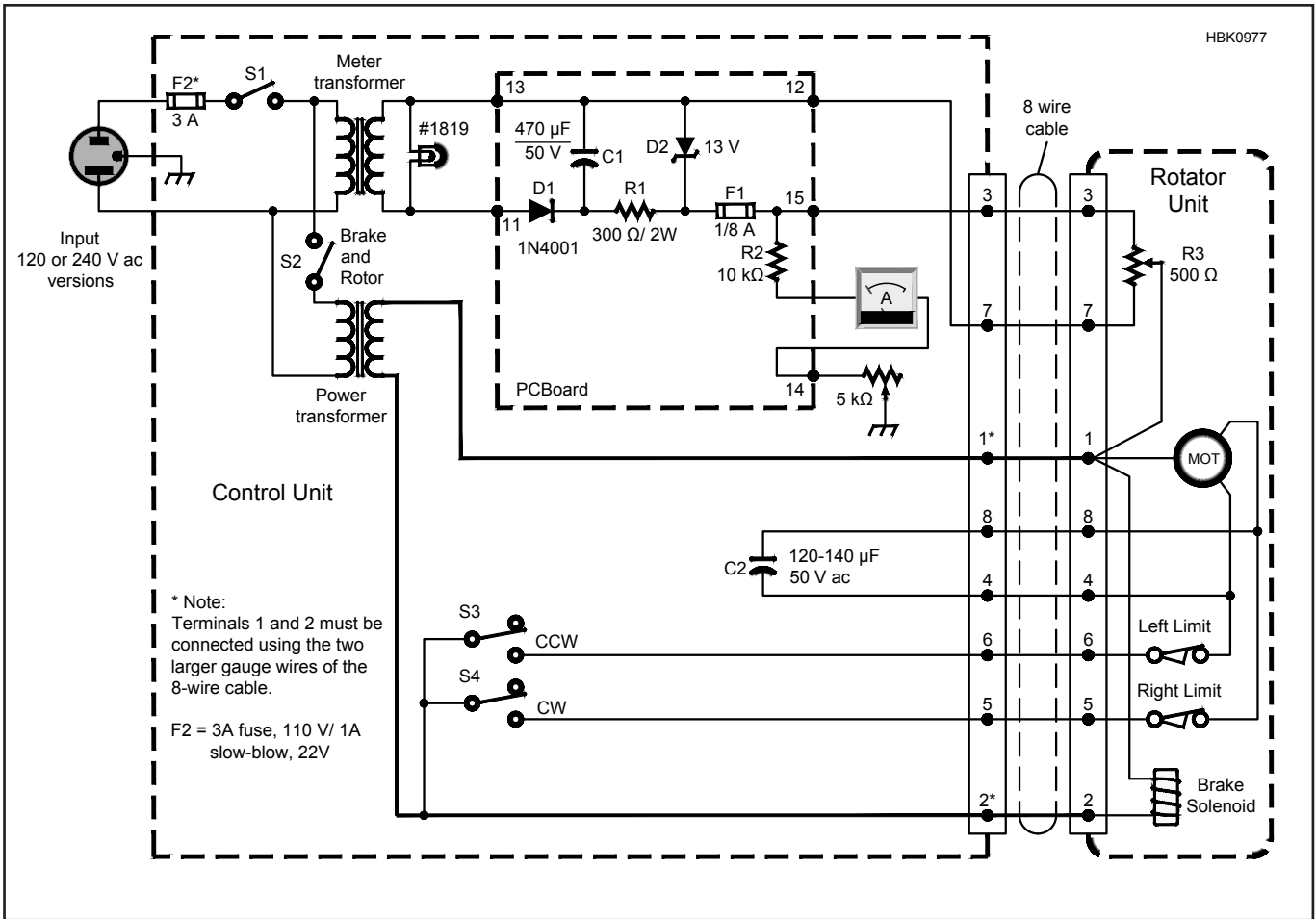

Figure 21.117 — The Hy-Gain Ham-IV/IVX control unit schematic. This control unit will also work with T2X rotators. (Circuit provided courtesy of Hy-Gain, Inc.)

The connection from the control unit to the rotator requires a multi-conductor control cable (no shield necessary). Most rotators require either 6- or 8-conductor cable. Solenoid brake circuits need heavier wire due to the higher current. If the wire used is too small, the extra resistance may cause enough voltage drop to result in erratic brake operation or slow turning. Check the manufacturer's recommendation for minimum wire size, which depends on the length of the cable. For the popular Ham-IV series, minimum recommended wire sizes are:

- Up to 125 feet: #18 (solenoid), #20 (all others)
- 125 to 200 feet: #16 (solenoid), #18 (all others)
- 200 to 300 feet: #14 (solenoid), #16 (all others)

Other rotators have similar requirements — consult the manufacturer's instructions.

At the rotator, connections can be made directly to a terminal strip under the unit or to a weatherproofed connector at the end of a short "pigtail." A nearby junction box where the pigtail and cable are attached can also be used.

Table 21.27
Ham-IV/IVX Connector and Cable Wiring

Pin numbers, colors, and resistance values from Ham-IV/IVX Instruction Manual

Pin	Color	Circuit
1	Black (heavy wire)	Solenoid and common
2	White (heavy wire)	Solenoid
3	Green	Position pot element, + end
4	Blue	Motor winding 1
5	Orange	Right limit switch
6	Yellow	Left limit switch
7	Brown	Position pot element, – end
8	Red	Motor winding 2

Resistance Checks — Read Between Terminals

1-2	Brake solenoid	0.75 Ω + cable or leads
1-8	½ Motor winding	2.5 Ω + cable or leads
1-4	½ Motor winding	2.5 Ω + cable or leads
1-6	½ Motor + switch	2.5 Ω + cable or leads
1-5	½ Motor + switch	2.5 Ω + cable or leads
8-4	Entire motor	5 Ω + cable or leads
8-5	Right limit switch	0 Ω + cable or leads
4-6	Left limit switch	0 Ω + cable or leads
3-7	Entire pot element	500 Ω
3-1	Pot wiper to element end 1	0 to 500 Ω
7-1	Pot wiper to element end 2	0 to 500 Ω

Note: readings 3-1 and 7-1 should add to 3-7 reading

Retrofit kits to replace terminal strips are available from several vendors. The Ham-IV family suggests an 8-pin Cinch-Jones connector with wiring and color code as shown in **Table 21.27**.

For terminal strip connections, use a weatherproofing grease found at electrical and automotive stores. Run the connecting cable down and away from the rotator to guide water away from it. Use a consistent color code at the rotator and the control unit.

Lightning protection is also recommended for rotator control cables. Several vendors make 8-line lightning protectors for rotators.

The protector must be well grounded and should be installed at a common entry point for all antenna system cables. See the **Safety** chapter for more about grounding and lightning protection practices.

Troubleshooting a rotator electrically can be done from the ground through resistance checks. Table 21.27 shows the nominal resistance values for the Ham-IV family of rotators. When making resistance checks, the control unit must be disconnected. Include the resistance of the cable or test leads when making resistance checks.

Antenna Material Tables

The Antenna Material Tables now appear in the online content for this chapter. The tables include:

- Copper Wire Specifications
- Antenna Wire Strength
- Guy Wires Lengths to Avoid
- Aluminum Alloy Specifications

21.14 References and Bibliography

- Adler, S., "A High-Power 160- and 80-Meter Transmitting Loop Antenna," *QST*, Apr. 2019, pp. 30 – 36.
- Belrose, J., VE2CV, "Short Antennas for Mobile Operation," *QST*, Sep. 1953, pp. 30 – 35.
- Black, B., W4SSY, "The W4SSY Spudgun," *QST*, Mar. 2009, pp. 67 – 69.
- Brown, G., "The Phase and Magnitude of Earth Currents Near Radio Transmitting Antennas," *Proc IRE*, Feb. 1935.
- Brown, G., Lewis R., and Epstein, J., "Ground Systems as a Factor in Antenna Efficiency," *Proc IRE*, Jun. 1937, pp. 753 – 787.
- Brown G., and Woodward, O., "Experimentally Determined Impedance Characteristics of Cylindrical Antennas," *Proc IRE*, Apr. 1945.
- Buchanan, C., W3DZZ, "The Multimatch Antenna System," *QST*, Mar. 1955, p. 22.
- Cebik, L., W4RNL, "A Simple Fixed Antenna for VHF/UHF Satellite Work," *QST*, Aug. 2001, pp. 38 – 42.
- Christman, A., "Elevated Vertical Antenna Systems," *QST*, Aug. 1988, pp. 35 – 42.
- Clement, J., VE6AB, "Gain Twist 75 Meter Mobile Monobander," *QST*, Jul. 2011, pp. 39 – 42.
- Devoldere, J., *ON4UN's Low-Band DXing*, 5th Edition (ARRL, 2011).
- Dome, R., "Increased Radiating Efficiency for Short Antennas," *QST*, Sep. 1934, pp. 9 – 12.
- Doty, A., Frey J., and Mills, H., "Characteristics of the Counterpoise and Elevated Ground Screen," Professional Program, Session 9, Southcon '83 (IEEE), Atlanta, GA, Jan. 1983.
- Doty, A., Frey, J., and Mills, H., "Efficient Ground Systems for Vertical Antennas," *QST*, Feb. 1983, pp. 20 – 25.
- Doty, A., technical paper presentation, "Capacitive Bottom Loading and Other Aspects of Vertical Antennas," Technical Symposium, Radio Club of America, New York City, Nov. 20, 1987.
- Doty, A., Frey, J., and Mills, H., "Vertical Antennas: New Design and Construction Data," *The ARRL Antenna Compendium, Volume 2* (ARRL, 1989), pp. 2 – 9.
- Fosberg, R., "Some Notes on Ground Systems for 160 Meters," *QST*, Apr. 1965, pp. 65 – 67.
- Grammer, G., "More on the Directivity of Horizontal Antennas; Harmonic Operation — Effects of Tilting," *QST*, Mar. 1937, pp. 38 – 40, 92, 94, 98.
- Green, H., "Design Data for Short and Medium Length Yagi-Uda Arrays," *Trans IE Australia*, Vol EE-2, No. 1, Mar. 1966.
- Griffith, A., W4ULD, "Capacitance Hats for HF Mobile Antennas," *QEX*, Jul./Aug. 1996, p. 16.
- Hansen, R., "Carter Dipoles and Resonant Dipoles," Allerton Antenna Applications Symposium, pp. 282 – 287, Monticello, IL, Sep 21 – 23, 2010.
- Leeson, D., "The Story of the Broadband Dipole," *QEX*, Nov./Dec. 2018, pp. 18 – 22.
- McCleish, K., W7TX, "Why An Antenna Radiates," *QST*, Nov. 1992, pp. 59 – 63.
- Mills, H., technical paper presentation, "Impedance Transformation Provided by Folded Monopole Antennas," Technical Symposium, Radio Club of America, New York City, Nov. 20, 1987.
- Myers, B., "The W2PV Four-Element Yagi," *QST*, Oct. 1986, pp. 15 – 19.
- Reisert, J., "The 3/8-Wavelength Vertical — A Hidden Gem", *QST*, Apr. 2019, pp. 44 – 47.
- Richard, L., "Parallel Dipoles of 300-Ohm Ribbon," *QST*, Mar. 1957.
- Richmond, J., "Monopole Antenna on Circular Disc," *IEEE Trans on Antennas and Propagation*, Vol. AP-32, No. 12, Dec 1984.
- Richter, J., "Off-Center-Fed Dipole Antennas: Theory and Practice," *HF Dipole Antennas for Amateur Radio* (ARRL, 2019) pp. 105 – 123.
- Roberts, B., "Input Impedance of a Folded Dipole," *RCA Review*, Jun 1947.
- Schelkunoff, S., "Theory of Antennas of Arbitrary Size and Shape," *Proc. IRE*, Sep. 1941; corrections Nov. 1941 and Jan. 1943. Republished in *Proc. IRE*, September 1984.
- Schulz, W., "Designing a Vertical Antenna," *QST*, Sep. 1978, pp. 19 – 21.
- Sevick, J., "The Ground-Image Vertical Antenna," *QST*, Jul. 1971, pp. 16 – 17, 22.
- Sevick, J., "The W2FMI 20-Meter Vertical Beam," *QST*, Jun. 1972, pp. 14 – 18.
- Sevick, J., "The W2FMI Ground-Mounted Short Vertical," *QST*, Mar. 1973, pp. 13 – 18, 41.
- Sevick, J., "A High Performance 20-, 40- and 80-Meter Vertical System," *QST*, Dec. 1973.
- Sevick, J., "Short Ground-Radial Systems for Short Verticals," *QST*, Apr. 1978, pp. 30 – 33.
- Siwiak, K., and Quick R., "Small Gap-resonated HF Loop Antenna Fed by a Secondary Loop," *QEX*, Jul./Aug. 2018, pp. 12 – 17.
- Smith C., and Johnson, E., "Performance of Short Antennas," *Proc IRE*, Oct. 1947.
- Stanley, J., "Optimum Ground Systems for Vertical Antennas," *QST*, Dec. 1976, pp. 13 – 15.

- Stearns, S., K6OIK, "Antenna Modeling for Radio Amateurs," presented at ARRL Pacificon Antenna Seminar, 2017, archived at www.fars.k6ya.org/docs.
- Stearns, S., K6OIK, "Antennas: The Story from Physics to Computational Electromagnetics," Antenna Seminar, ARRL Pacificon, San Ramon, CA, Oct. 19 – 21, 2019.
- Stephens, R., "Admittance Matching the Ground-Plane Antenna to Coaxial Transmission Line," Technical Correspondence, *QST*, Apr. 1973, pp. 55 – 57.
- Sumner, D., "Cushcraft 32-19 'Boomer' and 324-QK Stacking Kit," Product Review, *QST*, Nov. 1980, pp. 48 – 49.
- Sykes, B., "Skeleton Slot Aerials," *RSGB Bulletin*, Jan. 1953.
- Tai C., and Long, S., "Dipoles and Monopoles," Chapter 4 in *Antenna Engineering Handbook*, 3rd Edition, Johnson, R., Ed. (McGraw-Hill, 1993).
- Roberts, W. Van B., "Input Impedance of a Folded Dipole," *RCA Review*, Jun. 1947.
- Williams, E., "Radiating Characteristics of Short-Wave Loop Aerials," *Proc IRE*, Oct. 1940.
- Witvliet B., et al, "Near Vertical Incidence Skywave Propagation: Elevation Angles and Optimum Antenna Height for Horizontal Dipole Antennas," *IEEE Antennas and Propagation Magazine*, Vol. 57, No. 1, Feb. 2015, pp. 129 – 146.
- Johnson, R., *Antenna Engineering Handbook*, 3rd Edition (McGraw-Hill, 1993).
- Jordan E., and Balmain, K., *Electromagnetic Waves and Radiating Systems*, 2nd Edition (Prentice-Hall, 1968).
- Keen, R., *Wireless Direction Finding*, 3rd Edition (Wireless World, 1938).
- King, R., *Theory of Linear Antennas* (Harvard University Press, 1956).
- King, R., Mimno, H., and Wing, A., *Transmission Lines, Antennas and Waveguides* (Dover Publications, 1965).
- King, Mack and Sandler, *Arrays of Cylindrical Dipoles* (London: Cambridge Univ Press, 1968).
- Knitter, M., Ed., *Loop Antennas — Design and Theory* (National Radio Club, 1983).
- Knitter, M., Ed., *Beverage and Long Wire Antennas — Design and Theory* (National Radio Club, 1983).
- Kraus, J., *Electromagnetics* 4th Edition (McGraw-Hill Book Co, 1991).
- Kraus, J., *Antennas*, 2nd Edition (McGraw-Hill, 1988).
- Laport, E., *Radio Antenna Engineering* (McGraw-Hill, 1952).
- Lawson, J., *Yagi-Antenna Design*, 1st Edition (ARRL, 1986).
- Lee, P., *The Amateur Radio Vertical Antenna Handbook*, 2nd Edition (Cowen Publishing Co., 1984).
- Leeson, D., *Physical Design of Yagi Antennas* (ARRL, 1992).
- Lowe, A., *Reflector Antennas* (IEEE Press, 1978).
- Maxwell, M., *Reflections — Transmission Lines and Antennas* (ARRL, 1990).
- Maxwell, M., *Reflections II — Transmission Lines and Antennas* (Worldradio Books, 2001).
- Miller, G., *Modern Electronic Communication* (Prentice Hall, 1983).
- Misek, V., *The Beverage Antenna Handbook* (V. A. Misek, 1977).
- Moreno, T., *Microwave Transmission Design Data* (McGraw-Hill, 1948).
- Moxon, L., *HF Antennas for All Locations* (Radio Society of Great Britain, 1982).
- Ramo and Whinnery, *Fields and Waves in Modern Radio* (John Wiley & Sons, 1944).
- Rumsey, V., *Frequency Independent Antennas* (Academic Press, 1966).
- Saveskie, P., *Radio Propagation Handbook* (Tab Books, Inc, 1980).
- Schelkunoff, S., *Advanced Antenna Theory* (John Wiley & Sons, 1952).
- Schelkunoff S., and Friis, H., *Antennas Theory and Practice* (John Wiley & Sons, 1952).
- Sevick, J., *Transmission Line Transformers* (Noble Publishing, 1996).
- Skilling, H., *Electric Transmission Lines* (McGraw-Hill Book Co, 1951).
- Slurzburg, M., and Osterheld, W., *Electrical Essentials of Radio* (McGraw-Hill Book Co, 1944).
- Southworth, G., *Principles and Applications of Waveguide Transmission* (D. Van Nostrand Co, 1950).
- Straw, R., Ed., *The ARRL Antenna Book*, 21st ed. (Newington: ARRL, 2007).
- Terman, F., *Radio Engineers' Handbook*, 1st ed. (McGraw-Hill, 1943).
- Terman, F., *Radio Engineering*, 3rd Edition (McGraw-Hill, 1947).
- Uda S., and Mushiake, Y., *Yagi-Uda Antenna* (Sasaki Publishing Co, 1954). [Published in English — Ed.]
- Viezbicke, P., "Yagi Antenna Design," NBS Technical Note 688 (US Dept of Commerce/National Bureau of Standards, Boulder, CO), Dec. 1976.
- Welch, G., *Wave Propagation and Antennas* (D. Van Nostrand Co, 1958).
- Zavrel, R., *Antenna Physics: An Introduction* (ARRL, 2016).
- The GIANT Book of Amateur Radio Antennas* (Tab Books, 1979).
- IEEE Standard Dictionary of Electrical and Electronics Terms*, 3rd Edition (IEEE, 1984).
- Radio Broadcast Ground Systems*, available from Smith Electronics, Inc, 8200 Snowville Rd, Cleveland, OH 44141.
- Radio Communication Handbook*, 5th Edition (RSGB, 1976).

TEXTBOOKS ON ANTENNAS

RDF BIBLIOGRAPHY

McCoy, "A Linear Field-Strength Meter," *QST*, Jan. 1973, p. 18.

Moell and Curlee, *Transmitter Hunting: Radio Direction Finding Simplified*, Blue Ridge Summit, PA: TAB/McGraw-Hill. (This book, available from ARRL, includes plans for the Roanoke Doppler RDF unit and in-line air attenuator, plus VHF quads and other RDF antennas.)

Moell, "Transmitter Hunting — Tracking Down the Fun," *QST*, Apr. 1993, p. 48 and May 1993, p. 58.

Moell, "Build the Handy Tracker," *73 Magazine*, Sep. 1989; Nov. 1989.

O'Dell, "Simple Antenna and S-Meter Modification for 2-Meter FM Direction Finding," *QST*, Mar. 1981, p. 43.

O'Dell, "Knock-It-Down and Lock-It-Out Boxes for DF," *QST*, Apr. 1981, p. 41.

Ostapchuk, "Fox Hunting is Practical and Fun!" *QST*, Oct. 1998, pp. 68 – 69.

Rickerd, "A Cheap Way to Hunt Transmitters," *QST*, Jan. 1994, p. 65.

RDF RESOURCES

Homing In www.homingin.com — website by KØOV on direction finding techniques and activities Amateur Radio Direction Finding (IARU Region II)

www.ardf-r2.org/iaru/ — ARDF activities and organizations in IARU Region II Radio Direction Finding

en.wikipedia.org/wiki/Direction_finding — a general site on RDF with links to related subjects DX Zone RDF Links

www.dxzone.com/catalog/Operating_Modes/Radio_Direction_Finding — a page of links to RDF articles and websites

